

OWNER'S MANUAL
INSTALLATION INSTRUCTIONS

WINEGARD®

RV DIGITAL SATELLITE SYSTEM

with Digital Elevation Sensor FOR WINNEBAGO INDUSTRIES

WI-DM04 - Single Coax Installation
WI-DM54 - Dual Coax Installation

U.S. PATENT NO. 5,532,710
Made in U.S.A.

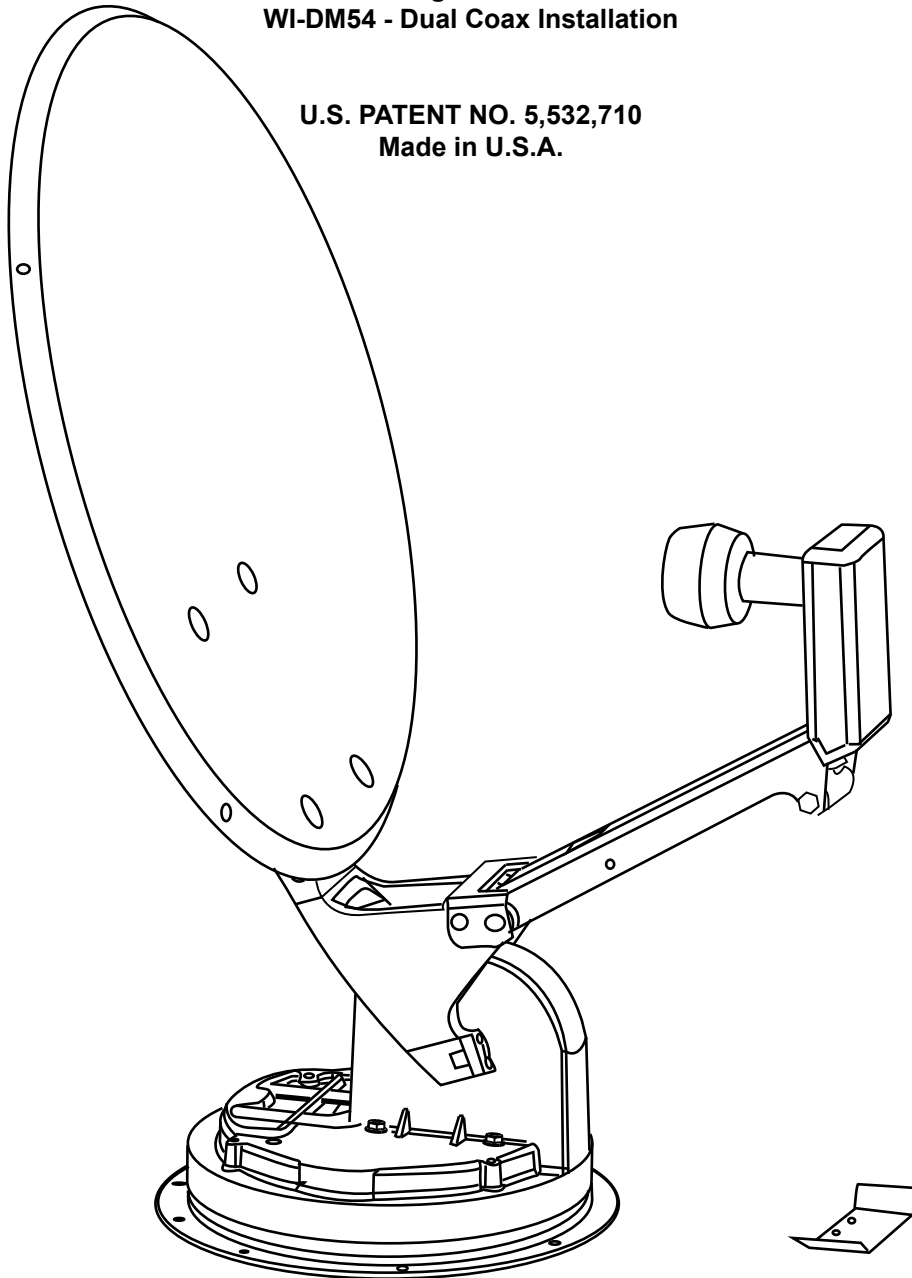

Winegard Company • 3000 Kirkwood St. • Burlington, IA 52601-2000
319/754-0600 • FAX 319/754-0787 • www.winegard.com
Printed in U.S.A. © Winegard Company 2003, 2006 2451071 Rev5 12/12

OPERATION

STEP 1. Step outside your vehicle and, using a compass, determine which direction is North. (Standing in or near vehicle can give you an incorrect reading.) The more accurately you determine North, the easier it will be to find the satellite(s).

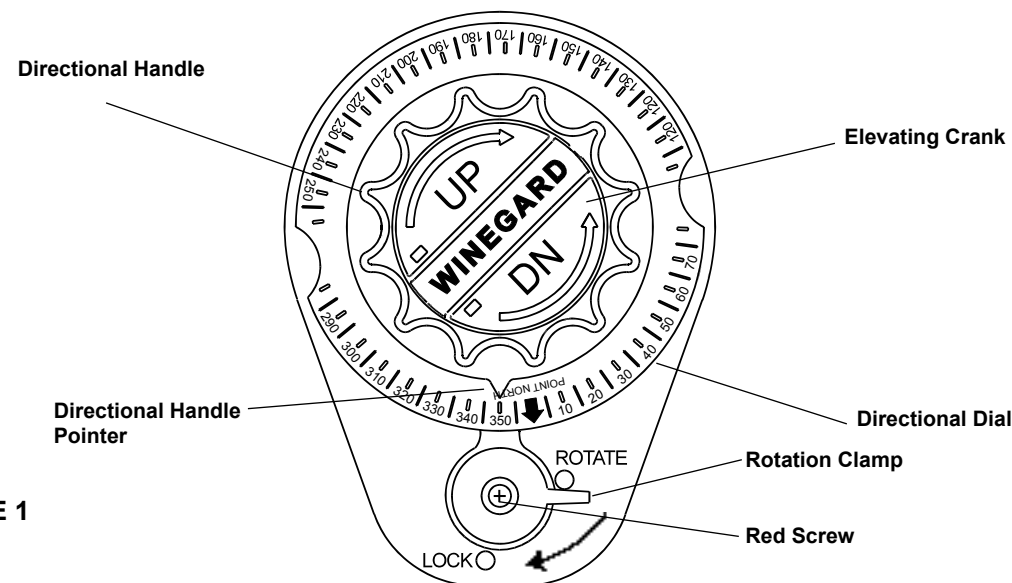

FIGURE 1

Step 2. Using satellite receiver, determine correct elevation for your location. See your receiver manual for details on how to obtain setup information.

Step 3. Press button on Winegard Digital Display Wall plate. If antenna is in travel position the display will show LL for Low Limit; HL for High Limit, will appear when dish is in up position.

Step 4. Crank elevation handle to raise antenna. Stop cranking when readout displays correct elevation for your location.

Step 5. Rotate antenna **VERY SLOWLY** until correct satellite signal is acquired. NOTE: Rotate 3° and then stop. DO NOT rotate continuously, even if you are rotating slowly. If you notice the elevation angle has changed, it could be due to the following reasons:

1. RV is not parked level.
2. Antenna system is mounted to a slightly sloped RV roof. (This is not a problem. **When you have rotated the antenna so it is facing in approximately the right azimuth [compass direction], simply adjust to correct elevation and continue searching for signal.**)

Special Notes: When you have detected the satellite signal, adjust the antenna up/down and left/right for strongest signal your receiver displays. Due to variations in receivers and installation methods, you may find the elevation numbers, after peaking on the strongest signal, no longer match what the receiver recommended. This is normal. The elevation sensor should always get you close enough to pick up a signal to peak on. If display turns off while you're searching, just push button for another minute of operation. After a little practice, most people find the signal in 30 to 50 seconds.

Trouble Shooting

- If digital display reads EE, check wiring and connection. If these are done incorrectly, it will affect operation.
- Rotate antenna **VERY SLOWLY** until correct satellite signal is acquired.

For replacement parts, contact Winegard Company. Customer Service. Hours are 7:00 a.m. to 5:00 p.m., Monday - Thursday, and 7:00 a.m. to 4:00 p.m. Friday, Central Time. Call toll-free 1-800-288-8094. Credit card only, \$5.00 minimum order.

TUNING ANTENNA

STEP 1. Your receiver should indicate it is receiving a signal. To tune your antenna for the best signal strength, **slowly** move the antenna left, then right until you have found the position that gives the highest signal strength. **It is important to turn the antenna slowly; since the signal is digital the receiver takes a few seconds to lock on.**

STEP 2. Place rotation clamp in the **LOCK** position. This prevents the antenna from moving and losing the signal.

STEP 3. **Slowly** raise, then lower the antenna until you have peaked the signal. **You are now ready to watch satellite TV!**

LOWERING ANTENNA TO TRAVEL POSITION

STEP 1. Set rotation clamp to the **ROTATE** position.

STEP 2. Rotate antenna until pointer on directional handle aligns with the red screw on the rotation clamp.

STEP 3. Turn elevating crank (counter clockwise) **in direction of "DOWN" arrow until resistance is met.** The number of turns will vary according to the elevation angle the antenna was set to.

STEP 4. Move rotation clamp to the **LOCK** position. Antenna is now locked in travel position.

STEP 5. Snap elevation crank into place.

CAUTION: NEVER LOWER ANTENNA IN ANY POSITION EXCEPT TRAVEL POSITION.



To order receivers or programming please call the Winegard receiver hotline: 1-(866) 609-9374.

DO'S

1. Do check parking location for obstructions before raising antenna.
2. Do carefully raise, lower and rotate — if difficult, check for cause.
3. Do rotate slowly when searching for the satellite(s) and check fine tuning on TV set to make sure it is properly adjusted.
4. **lower antenna before moving vehicle.**
5. Activate programming by calling programming service for your receiver.

DON'T'S

- 1.
2. Don't force elevating crank up or down. Check for cause of trouble.
3. Don't rotate directional handle hard against stops.
4. Don't apply paint over top of base plate or anywhere on lift.
5. Don't apply sealing compound on gear housing.

TROUBLE SHOOTING

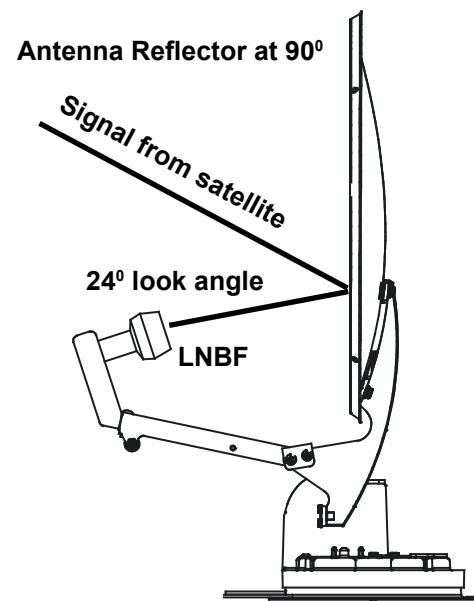

FIGURE 2

1. Be sure you have a clear line of sight. The signal from the satellite(s) **WILL NOT** pass through trees, buildings, mountains etc. Remember the antenna has a 24° offset, this means that when the antenna is straight up and down, (90°) it is looking 24° into the sky. See Fig. 2.
2. Do you have the TV set tuned for the correct channel 3 or 4 (same channel as output of receiver)?
3. Have you entered the correct zip for the area you are *currently* in? If the zip code is wrong, the antenna will be looking in the wrong direction or at the wrong elevation for the satellite signal you want.
4. Check connections at receiver, TV, and antenna.
5. Check the TV. Does it receive pictures from off-air TV stations/VCR?
6. Retune system for best picture, using procedure on page 3.
7. Inspect antenna. Make sure that it has not been damaged. If antenna is even slightly bent, the receiver may not receive any signal.
8. Contact Dealer or Winegard Service Department.

ANTENNA DOES NOT ROTATE, OR IS HARD TO ROTATE

1. Inspect antenna on roof. Make sure that mount has not been damaged.
2. Check for caulking between gear housing and baseplate.
3. Be sure cables are not binding, and that they are installed properly.
4. Contact Dealer or Winegard Service Department.

ANTENNA DOES NOT RAISE, OR IS HARD TO RAISE

1. Inspect antenna on roof. Make sure that mount has not been damaged.
2. Check for caulking on elevating shaft.
4. Contact Dealer or Winegard Service Department.

LCD DISPLAY CODES

HL.....High Limit
 LL.....Low Limit
 Lo.....Battery Low
 Er.....Communication Error
 — —.....Initializing

NOTE: Initialization may take up to 5 seconds.

Based on 5 minutes a day of usage, standard new alkaline batteries should last 88 days.

THINGS YOU NEED

Screwdrivers (Phillips and slot)
 1-3/4" hole saw
 7/16" wrench

ABS glue
 Drill w/1/8" bit
 Tape measure

Non-hardening sealant
 (Check manufacturer's specifications for compatibility with your roof material)

Winegard's Digital Elevation Sensor has been INSTALLED and CALIBRATED at the factory.

INSTALLATION & ASSEMBLY

STEP 1. Choose a location on the roof for dish that will allow dish to raise and rotate without interfering with other roof-mounted equipment. Make sure inside ceiling plate is easily accessible, and with no obstructions that would interfere with operation.

Figure 3 shows minimum distance (10") antenna should be located from edge of vehicle roof. It is recommended that you check with your dealer or manufacturer for provisions that may have been made in the roof for antenna mounting; a reinforced roof area, or pre-wire installation from the factory.

FIGURE 3

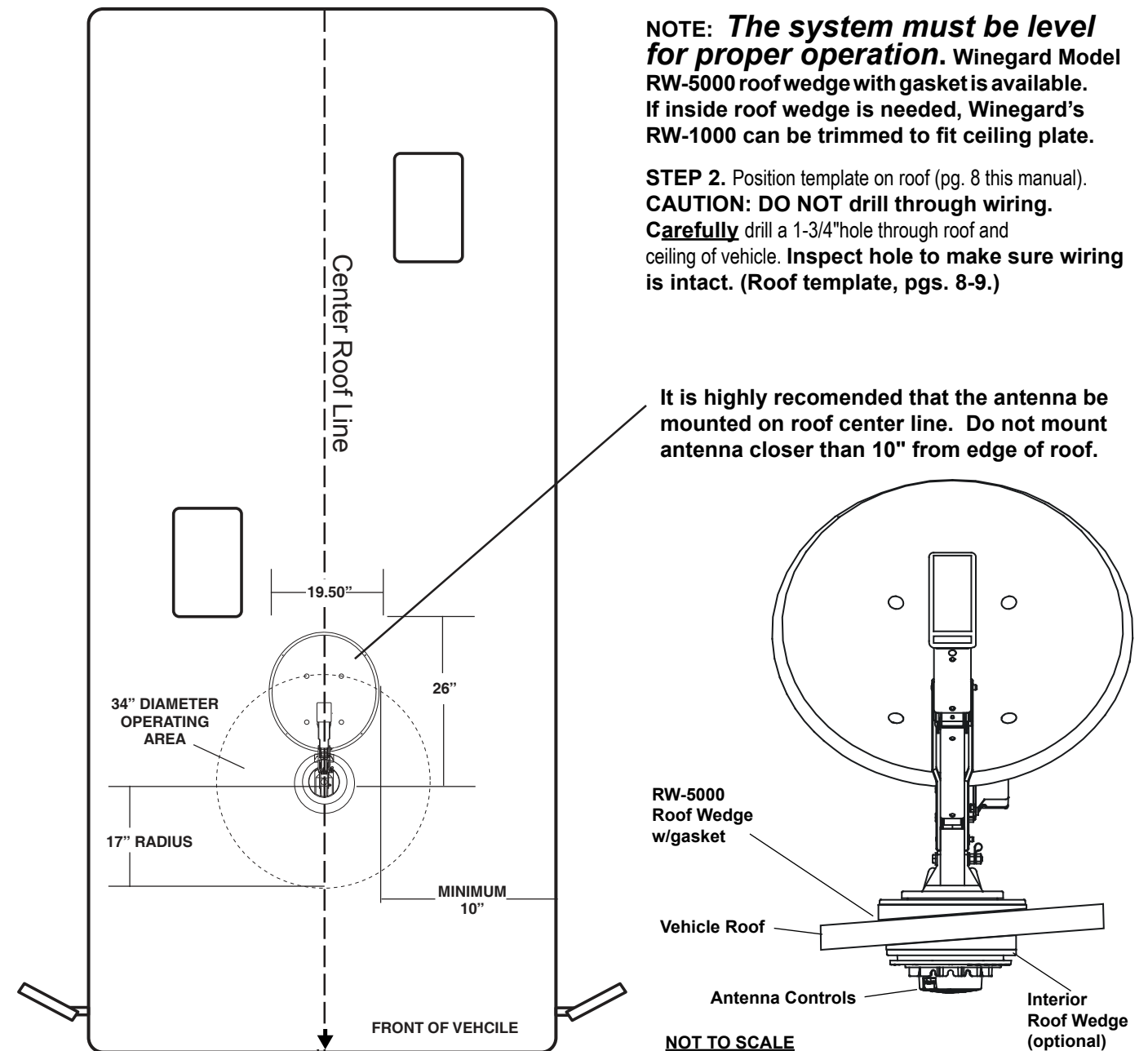

NOTE: The system must be level for proper operation. Winegard Model RW-5000 roof wedge with gasket is available. If inside roof wedge is needed, Winegard's RW-1000 can be trimmed to fit ceiling plate.

STEP 2. Position template on roof (pg. 8 this manual). **CAUTION: DO NOT drill through wiring.** **Carefully** drill a 1-3/4" hole through roof and ceiling of vehicle. **Inspect hole to make sure wiring is intact.** (Roof template, pgs. 8-9.)

It is highly recommended that the antenna be mounted on roof center line. Do not mount antenna closer than 10" from edge of roof.

RW-5000
 Roof Wedge
 w/gasket

Vehicle Roof

Antenna Controls

Interior
 Roof Wedge
 (optional)

NOT TO SCALE

STEP 3. Assemble dish to backup using bolts and nuts provided, Figure 4.

STEP 4. Mount dish on roof in upright position. Rotate clockwise to stop, Figure 5. Dish will be toward back of vehicle when in stowed or travel position. The word FRONT is embossed on the base. This should face front of vehicle. Secure to roof using screws (provided). The travel bracket should be mounted to roof 6-1/8" from base of dish, toward back of vehicle. See Figure 6.

NOTE: Apply non-hardening sealing compound to screw heads, coax access hole and edge of gasket under mount base.

Install the vent tube on the back of the mount base (This is the side opposite the word FRONT). The hole for the vent tube is shown in Figure 6A. **CAUTION: DO NOT seal hole in vent tube.** Put sealant around the outside of the vent tube, approximately 1/2" from end. Push the vent tube into the hole. The sealant will seal the hole as you push in. Leave approximately 2 to 2-1/2" of the vent tube extending from the hole. Put a small amount of sealant on the roof under the vent tube end to hold in place.

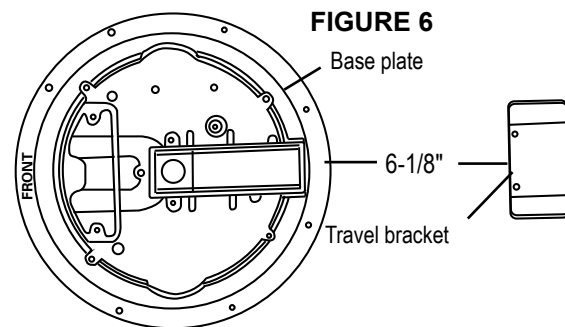
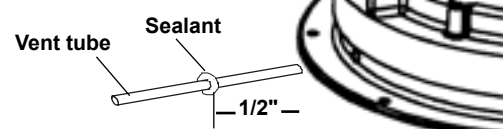

FIGURE 6A



CAUTION: DO NOT GET sealing compound between Base Plate and Rotating Gear Housing. DO NOT PAINT top of Base Plate or around Rotating Gear Housing.

STEP 5. Facing the front of the dish, note the coax attached to side of the feed arm. Measure 24" of coax from this point. **Do not cut.** Put coax around mount base, Figure 5.

STEP 6. Apply approved sealing compound over mounting screw heads.

STEP 7. Feed coax through the roof using cover plate (included with hardware), Figure 7. **Weatherproof cable entry** by applying sealant under lip of cable entry plate and where cable enters roof. Attach plate to roof with screws provided. Apply sealant over screws and around edge of roof-thru plate, making sure cable entry is sealed. Secure cables as necessary to prevent whipping. **If downlead connection must be made on top of roof, make sure to weatherproof connection!**

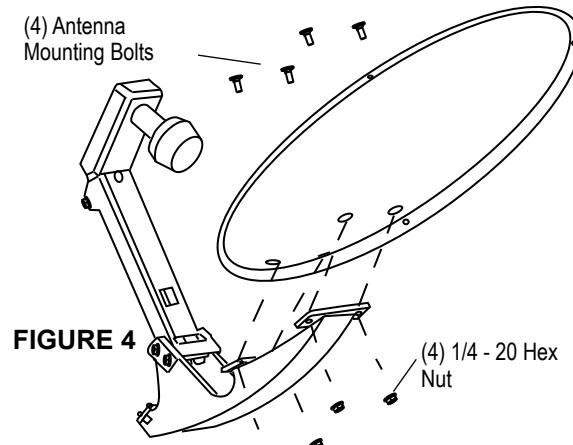

FIGURE 4

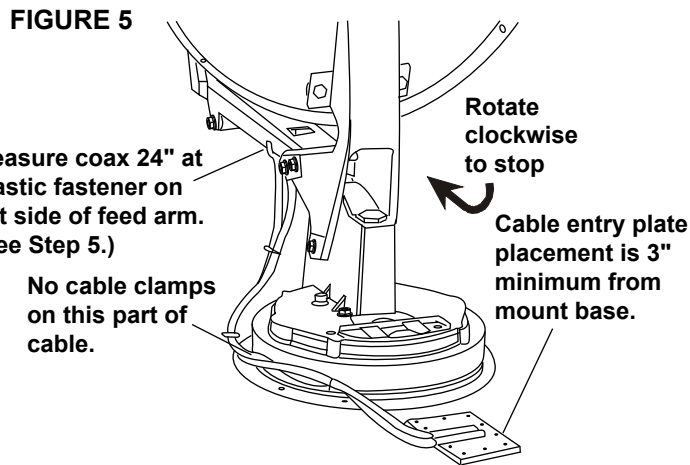

FIGURE 5

ANOTHER METHOD OF INSTALLING ROOF CABLE/ENTRY PLATE: Attach cable to roof using cable clamp. Use sealant to seal screw heads.

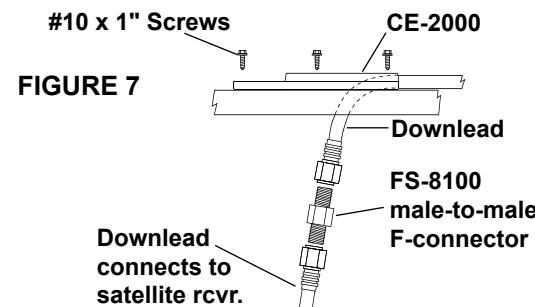
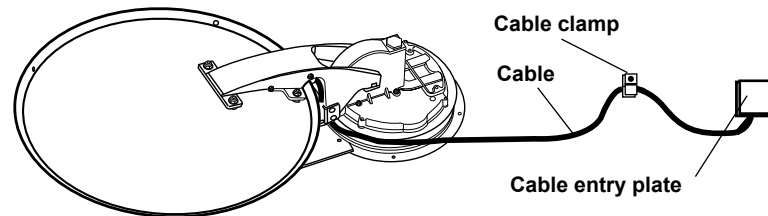
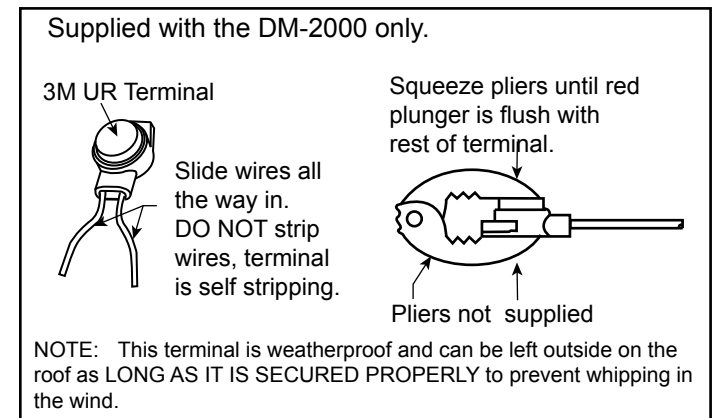
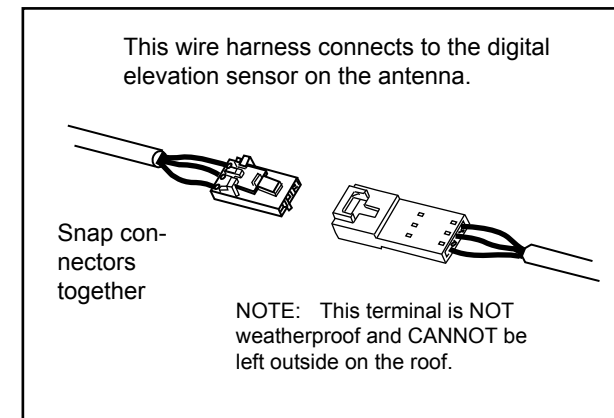

FIGURE 7

DIGITAL ELEVATION SENSOR ROOF CONNECTIONS

The illustrations below show the different methods of connecting wires at roof level. Method will depend on model. Wire colors **MUST MATCH**, i.e. red to red, green to green, black to black



INSIDE RV

STEP 8. Place the nut on the threaded rod.

STEP 9. Measure and cut the threaded rod with a hacksaw. Use the chart, Figure 8, to determine the length.

STEP 10. Remove the nut over the cut end of the threaded rod. This cleans the threads after cutting.

STEP 11. Thread the cut end of the rod into the hub,

STEP 12. Install the ceiling plate. The rotate/lock lever must point toward the rear of the vehicle.

Be sure rotate/lock lever is pointing toward back of vehicle and hole in ceiling aligns with hole in the ceiling plate.

NOTE: Make sure large and small keyways line up in the hub and directional handle!

STEP 13. Measure and cut the directional handle; see Figure 9 and chart, Figure 8. **NOTE:** A tube cutter is recommended for cutting the directional handle. This gives a square cut; a hacksaw does not. If using an extension, see Step 17.

Figure 10, page 8, shows what points to measure between, with and without a roof wedge.

STEP 14. The directional handle and threaded rod will fit roofs up to 5-1/4" thick. If you are using wedges

FIGURE 9

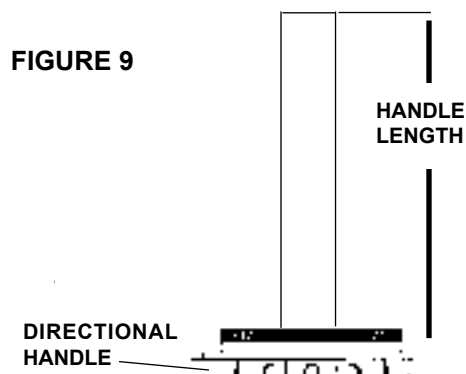

FIGURE 8

Roof Thickness	Directional Handle Length (Figure 9)	Threaded Rod Length	Worm Gear Shaft Length (Figure 11)
1-1/2"	2-7/8"	2-3/4"	2-7/8"
1-3/4"	3-1/4"	3"	3-1/8"
2"	3-1/2"	3-1/4"	3-1/2"
2-1/4"	3-7/8"	3-1/2"	3-7/8"
2-1/2"	4-1/8"	3-3/4"	4-1/8"
2-3/4"	4-1/2"	4"	4-1/2"
3"	4-3/4"	4-1/4"	4-3/4"
3-1/4"	5"	4-5/8"	4-7/8"
3-1/2"	5-1/4"	4-7/8"	5-1/8"
3-3/4"	5-5/8"	5-1/4"	5-1/2"
4"	5-3/4"	5-1/2"	5-3/4"
4-1/4"	6-1/8"	5-3/4"	6-1/8"
4-1/2"	6-1/2"	6"	6-1/4"
4-3/4"	6-5/8"	6-1/8"	6-3/8"
5"	6-7/8"	6-3/8"	6-5/8"
5-1/4"	7-1/8"	6-5/8"	7"
5-1/2"	7-3/8"	6-7/8"	7-1/4"
5-3/4"	7-5/8"	7-1/4"	7-1/2"
6"	7-7/8"	7-1/2"	7-3/4"
6-1/4"	8-1/8"	7"	8"
6-1/2"	8-1/2"	7-3/4"	8-1/4"
6-3/4"	8-3/4"	8"	8-1/2"
7"	9"	8-1/4"	8-7/8"
7-1/4"	9-3/8"	8-5/8"	9-1/8"
7-1/2"	9-5/8"	8-7/8"	9-3/8"
7-3/4"	9-7/8"	9-1/8"	9-5/8"
8"	10-1/8"	9-3/8"	10"
8-1/4"	10-3/8"	9-5/8"	10-1/4"
8-1/2"	10-3/4"	9-7/8"	10-3/8"
8-3/4"	11"	10"	10-5/8"
9"	11-1/4"	10-1/4"	11"
9-1/4"	11-1/2"	10-5/8"	11-1/4"
9-1/2"	11-3/4"	10-7/8"	11-1/2"
9-3/4"	12"	11-1/8"	11-3/4"
10"	12-3/8"	11-3/8"	12"
10-1/4"	12-5/8"	11-5/8"	12-1/4"
10-1/2"	12-7/8"	11-7/8"	12-1/2"

to compensate for roof/ceiling slope, be sure to allow for this extra thickness. You may add an extension to the directional handle for thicker roofs. Each extension will increase the length of the directional handle by 2-1/4".

STEP 15. Press the directional handle onto the hub. Point the arrow on the directional handle towards the rotate/lock lever to orient to the splines.

STEP 16. Install the washer and nut on the

FIGURE 10

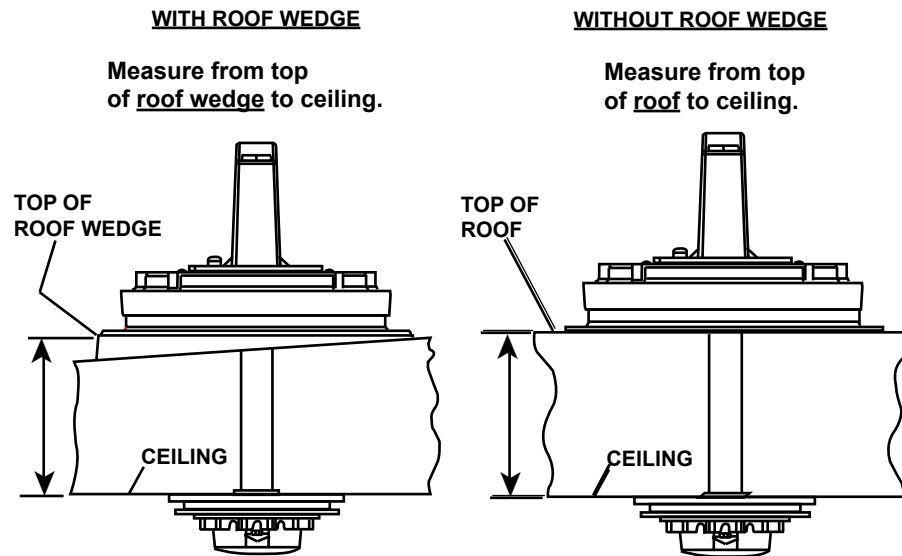
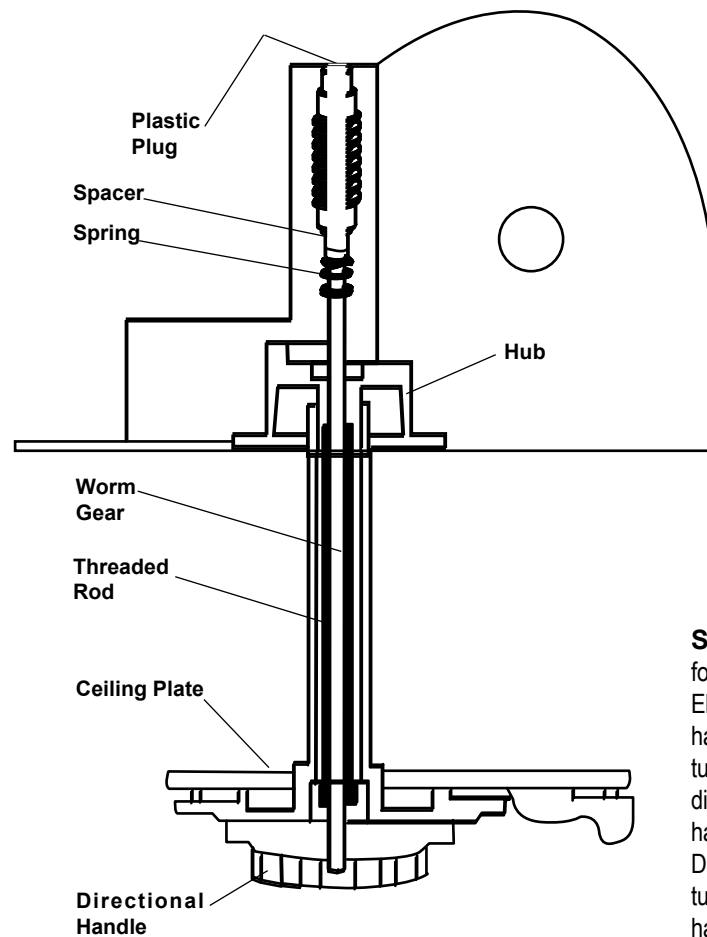

FIGURE 11



threaded rod. Tighten the nut enough to snug the directional handle to the hub.

STEP 17. IF YOU ARE USING AN EXTENSION, adjust the total length of the directional handle and extension by **cutting the directional handle**. After adjusting parts for proper roof thickness, glue the extension to the directional handle. Use ABS (plastic pipe) glue.

NOTE: For roofs thicker than 5-1/4", a longer aluminum hex shaft will be needed. Contact Winegard Company for this part.

CUTTING SHAFT LENGTH, Figure 3F:

Flip down handle on the elevating crank handle. Slide elevating crank handle up shaft until snug against directional handle. Mark the elevating shaft at inside bottom surface of crank handle housing, Figure 12. Cut shaft at mark, after removing crank handle. Reinstall crank.

STEP 18. Check system for proper operation. Elevate dish with crank handle. A minimum of 14 turns is needed to elevate dish. Then, move directional handle with dish elevated. Directional handle should turn freely. If possible, have someone watch to make sure coax does not bind or interfere with dish movement.

FIGURE 12

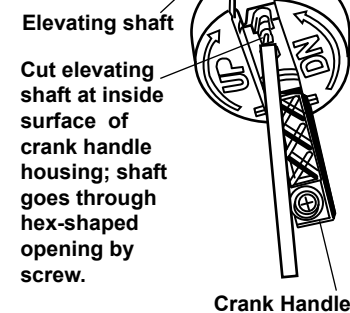

See template on reverse side.

Roof Template

↑
**ALIGN WITH
BASEPLATE
AREA MARKED
"FRONT"
POINT TO FRONT
OF VEHICLE**

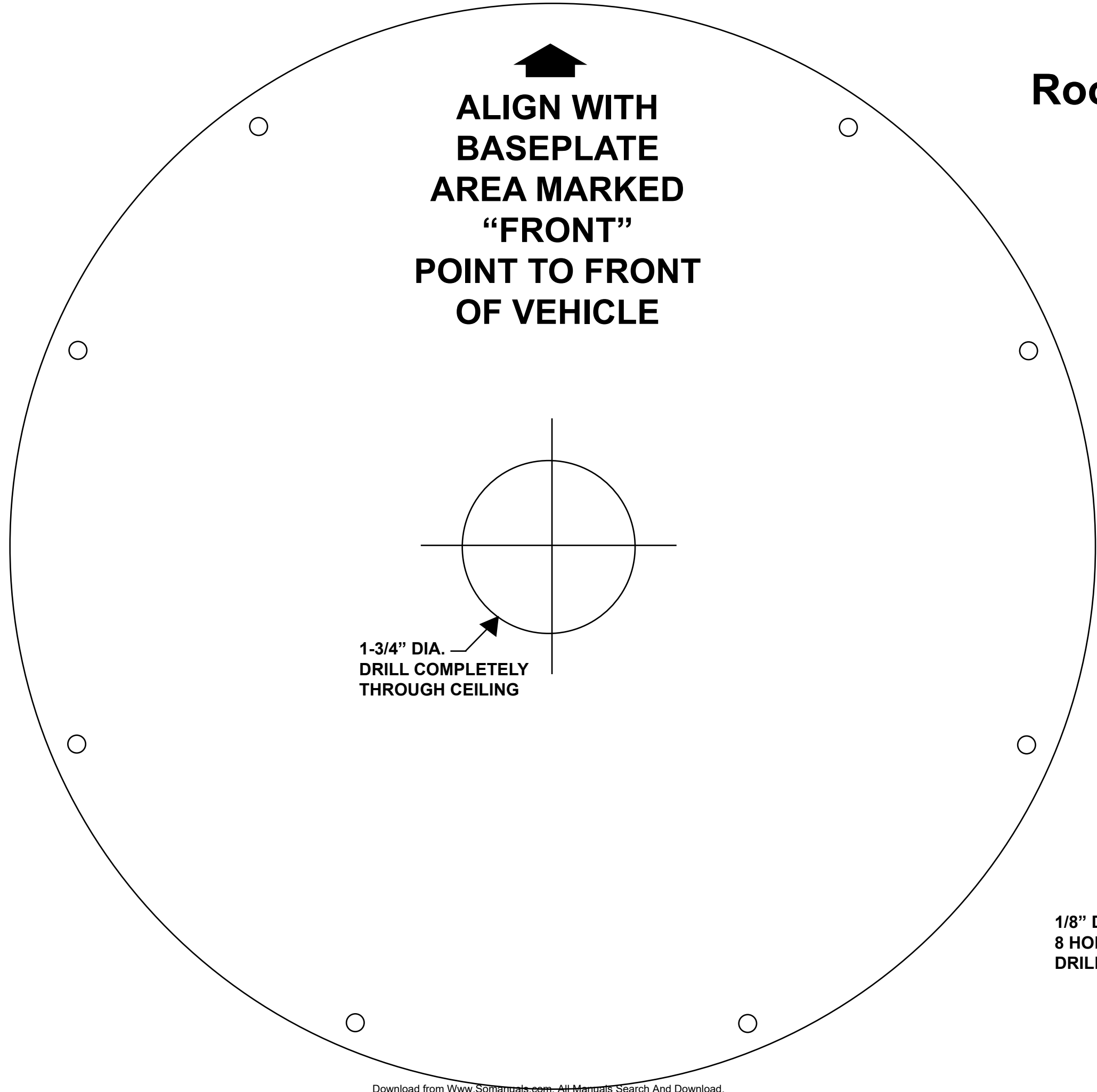

1-3/4" DIA. —
DRILL COMPLETELY
THROUGH CEILING

1/8" DRILL BIT
8 HOLES. DO NOT
DRILL THROUGH CEILING.

See template on reverse side.

CAUTION:
After **INITIAL INSTALLATION**,
the antenna **SHOULD ROTATE**
APPROXIMATELY 360° FROM
TRAVEL POSITION.

The pointer on the
DIRECTIONAL HANDLE
should point towards the **RED**
SCREW on the **ROTATION**
CLAMP when in **TRAVEL**
POSITION.

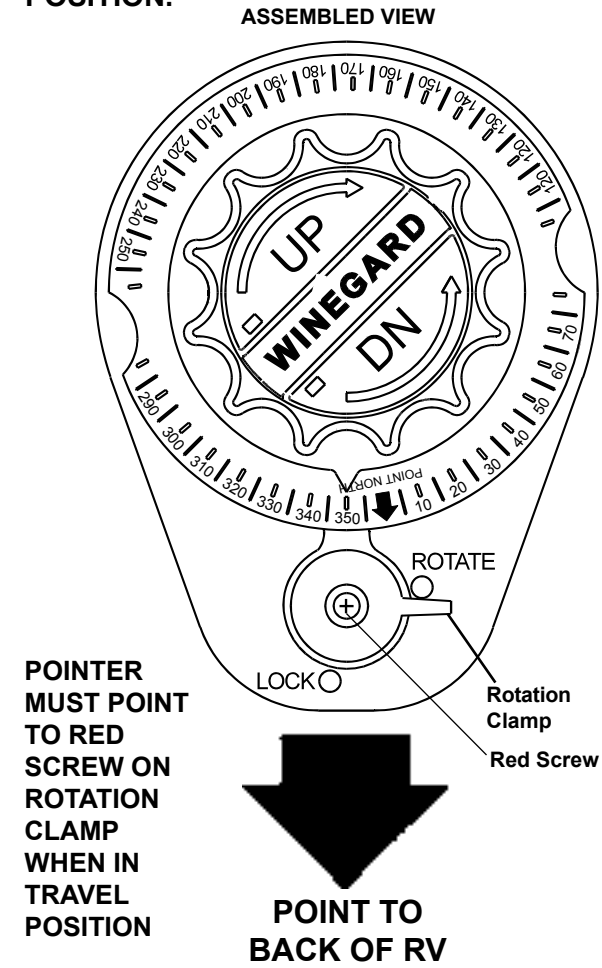

POINTER
MUST POINT
TO RED
SCREW ON
ROTATION
CLAMP
WHEN IN
TRAVEL
POSITION

CAUTION:
The antenna **MUST BE IN THE**
TRAVEL POSITION before
ALIGNING the Directional
Handle and Ceiling Plate.

Tighten screw snugly

FIGURE 13

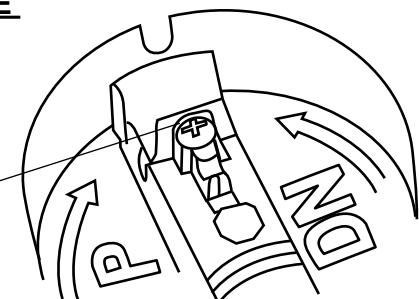
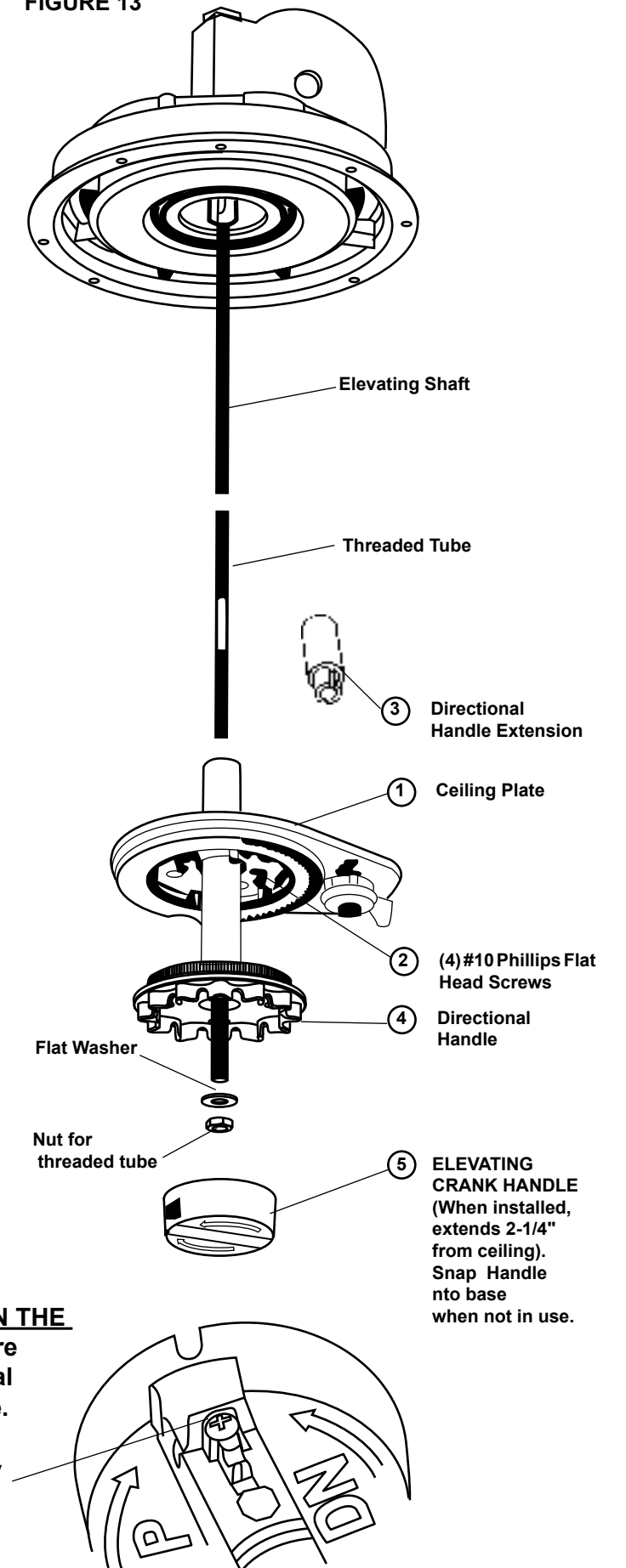

DIGITAL ELEVATION SENSOR INTERIOR WALLPLATE

Step 12. See Figure 14. If using the SM-1000 surface mount box, feed cable through hole in box.

STEP 13: Connect wires coming from sensor on roof to wall plate display in vehicle. It is important to properly connect the wires at the roof and the wall plate. (Plug will click when inserted properly.) The system is designed to use a 9 volt battery **OR** +12 VDC from vehicle. Do not use both! **IMPROPER WIRING WILL CAUSE DAMAGE TO THE PRODUCT.**

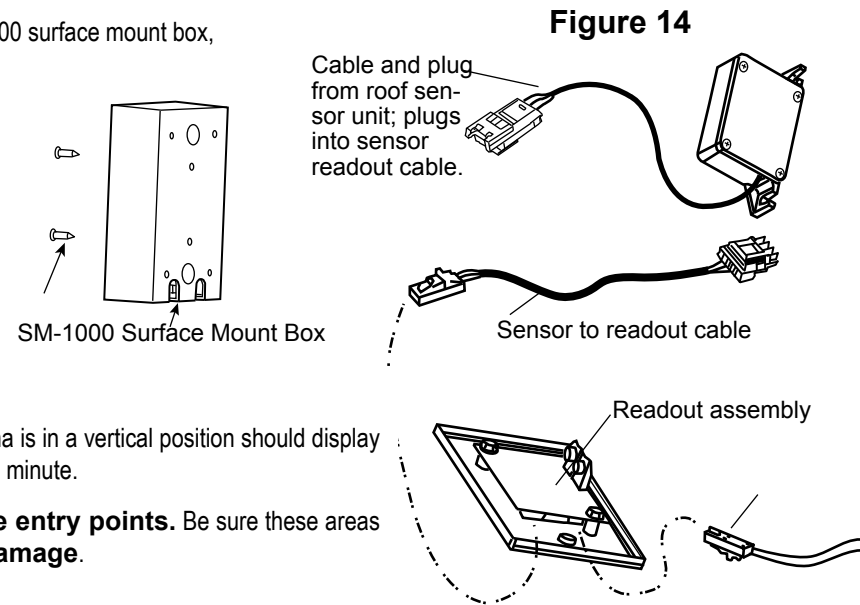

STEP 14: Pressing the button when the antenna is in a vertical position should display 24 ($\pm 1^\circ$). Display will automatically turn off after 1 minute.

STEP 15: Check connectors and cable entry points. Be sure these areas are properly sealed to prevent water damage.

OPERATION (Also on pages 2-3)

STEP 16: Using satellite receiver, find correct elevation for your location. See the receiver manual for details of setup information.

STEP 17: Press button on Winegard digital display wall plate. If antenna is in travel position, the display will show LL for Low Limit.

STEP 18: Crank elevation handle to raise antenna. Stop when readout displays correct elevation for your location. (Found on receiver setup menu.)

STEP 19: Rotate antenna VERY SLOWLY until correct satellite signal is acquired. NOTE: Rotate 3° and stop. DO NOT rotate

continuously even if you are rotating slowly. If the elevation angle has changed, it could be due to the following —

- Vehicle is not parked level.
- Antenna system mounted on slightly sloped roof. If this is the reason, after you have rotated the antenna to the approximate correct compass direction, adjust to correct elevation and continue search.

Special Notes: When you have found the satellite signal, adjust the antenna up/down and right/left for the strongest signal your receiver displays. Due to variation in receivers and installation methods, you may find the elevation numbers after peaking on strongest signal no longer match what the receiver display recommended. This is normal. The elevation sensor should always get you close enough to pick up a signal to peak on. If display turns off while you're searching, just push button for another minute of operation. With a little practice, most users find the signal in 30 to 50 seconds.

Replacement Parts

DISPLAY CODES

HL	High Limit
LL	Low Limit
Lo	Battery Low
Er	Communication Error
—	Initializing

NOTE: Initialization may take up to 5 seconds.

Figure 6

*** CAUTION: DO NOT connect to +12 VDC if using a 9 volt battery.**

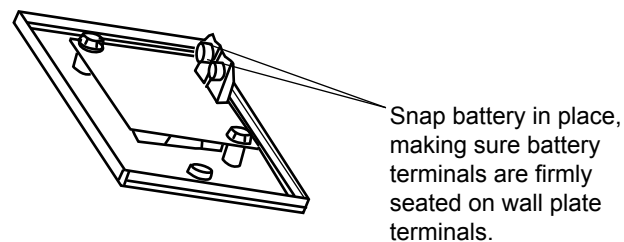

PARTS LIST

BACK VIEW

(2) 1/4-20 Hex Nut

Backup Frame

(2) E-Clip for 1/4" Pin

(2) 1/4" x 3.25 Pin

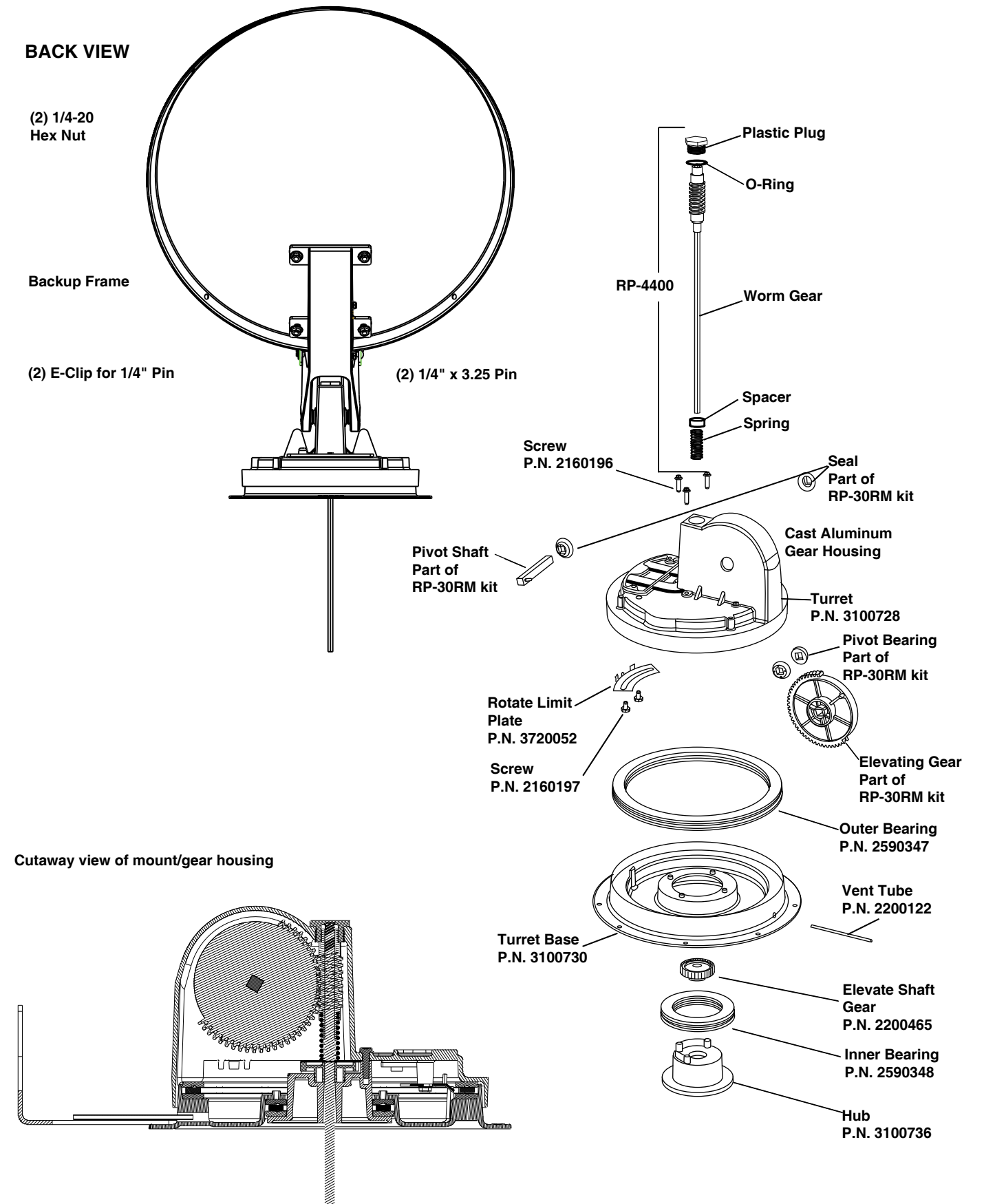

PARTS LIST

Location of elevation sensor on backup, installed and calibrated at the factory

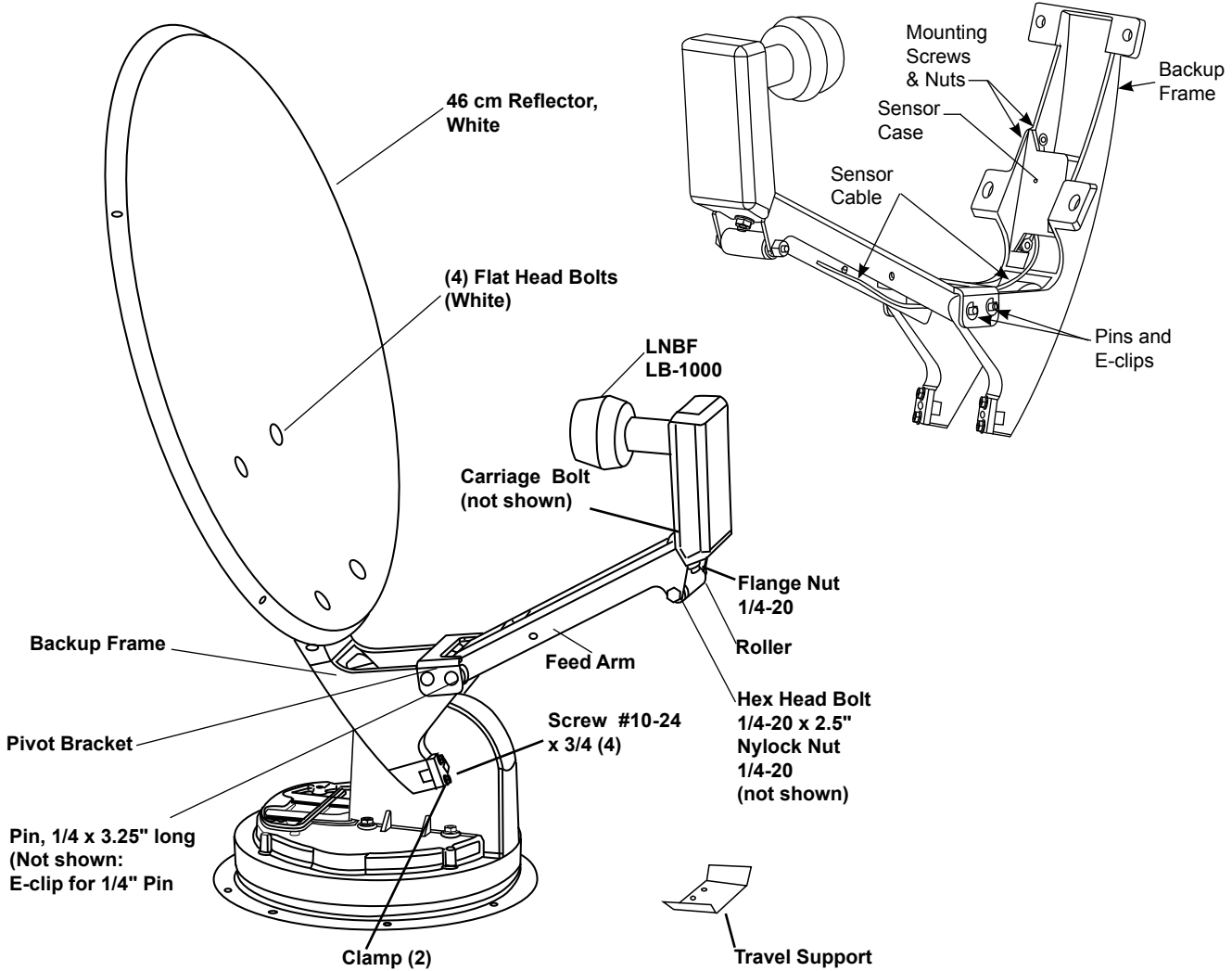

Sensor parts w/cable, installed at factory

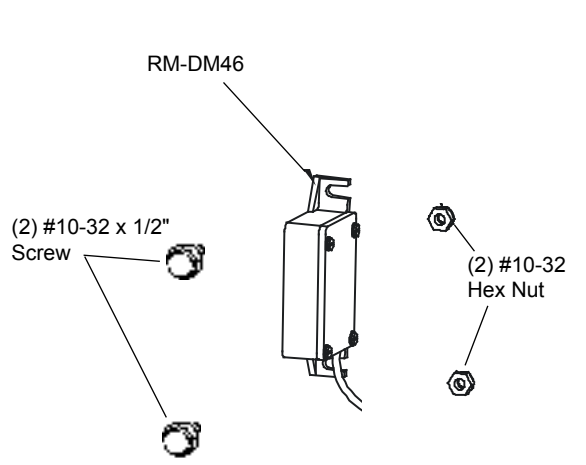

Interior wallplate display and parts

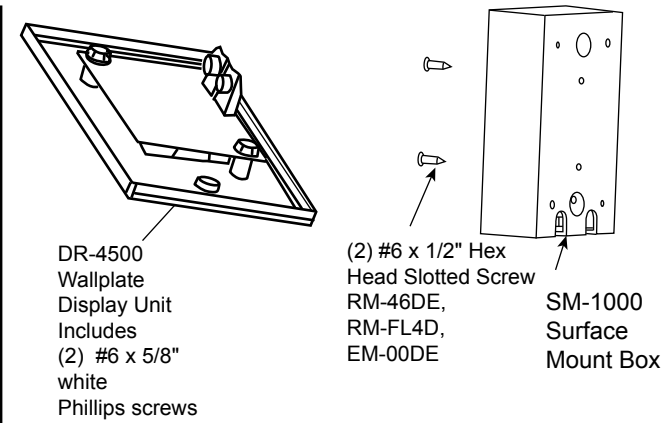

PARTS LIST

INTERIOR HARDWARE KIT RK-CEIL

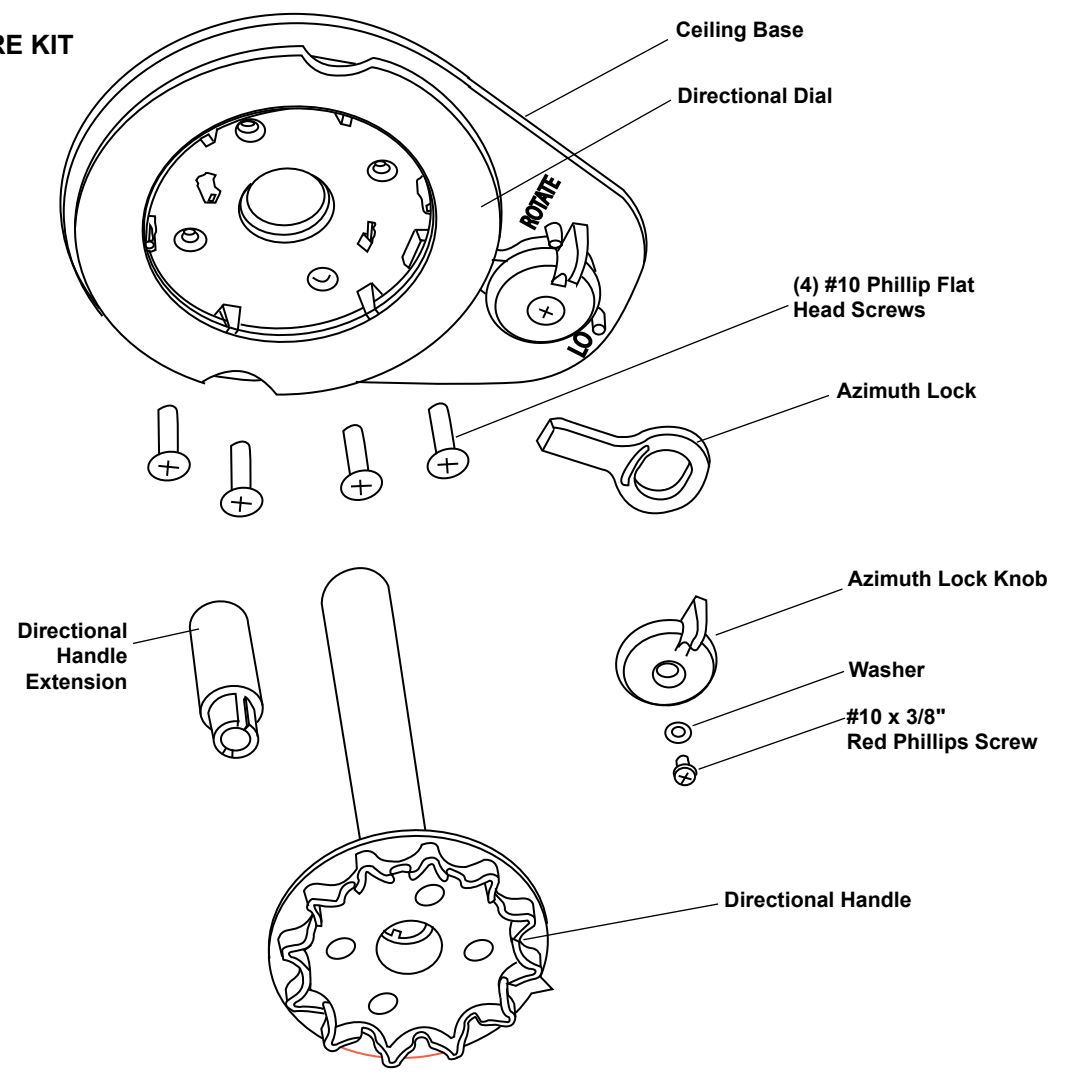

CRANK HANDLE KIT RK-HAND

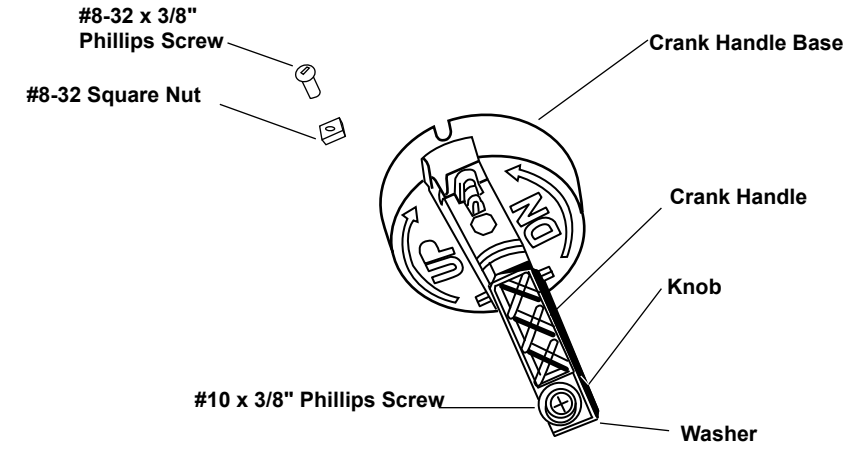

NOT TO SCALE

SPECIFICATIONS

ANTENNA & MOUNT

Height when raised	30" verticle max.
Height in the travel position	8" max.
Operating radius	17" (34" diameter circle)
Roof space required	26"
LNB	Compatible with DIRECTV®, DISH®, and Bell TV™ (northern U.S. and Canada)
Weight	12 lbs.
Color	Cool gray
Antenna height	20.9"
Antenna width	19.2"
F/D	0.59
Offset angle	24°
Frequency range	10.95 - 12.75 GHz
Gain:	
11.2 GHz	33.22 dBi
12.1 GHz	33.89 dBi
12.6 GHz	34.23 dBi
Aperture efficiency	73%
Cross polarization (on axis)	-21 dB
*Beamwidth at -3 dB	3.5°
*Beamwidth at -10 dB	7.0°
Ship weight:	20.6 lbs.

NOTES

DIRECTV® is a registered trademark of DIRECTV, Inc., a unit of Hughes Electronics Corporation.
DISH® is a registered trademark of DISH Network L.L.C.
Bell TV is a trademark of Bell Canada, Inc.

**WINEGARD MOBILE PRODUCTS LIMITED WARRANTY
(2 YEARS PARTS; 1 YEAR LABOR)**

Winegard Company warrants this product against defects in materials or workmanship for a period of two (2) years from the date of original purchase. During year one (1) of such warranty, Winegard Company will also pay authorized labor costs to an authorized Winegard dealer to repair or replace defective products. No warranty claim will be honored unless at the time the claim is made, Customer presents proof of purchase to an authorized Winegard dealer (to locate the nearest authorized Winegard dealer, contact Winegard Company, 3000 Kirkwood Street, Burlington, Iowa 52601, Telephone 800-288-8094 or visit www.winegard.com). Customer must provide proof of purchase with a dated sales receipt for the Winegard product to verify the product is under warranty. If the date of purchase cannot be verified, the warranty period shall be considered to begin thirty (30) days after the date of manufacture.

If a defect in material or workmanship is discovered, Customer may take the product to an authorized Winegard dealer for service. Customer must provide proof of purchase to verify the product is under warranty. If the product is brought to an authorized Winegard dealer for service prior to expiration of year one (1) of the warranty period and a defect in material or workmanship is verified by Winegard Technical Services, Winegard Company will cover the Winegard dealer's labor charges for warranty service. The Winegard dealer must contact Winegard Technical Services in advance for pre-approval of the service. Approval of the service is at the sole discretion of Winegard Company.

Alternatively, Customer may ship the product prepaid to Winegard Technical Services (located at 3111 Kirkwood Street, Burlington, Iowa 52601, Telephone 800-788-4417). Customer must return the product along with a brief description of the problem and provide Winegard Technical Services with Customer's name, address, and phone number. Customer must also provide proof of purchase to verify the product is under warranty. If the product is returned before the expiration of the warranty period, Winegard Company will (at its option) either repair or replace the product.

This Limited Warranty does not apply if the product has been damaged, deteriorates, malfunctions or fails from: improper installation, misuse, abuse, neglect, accident, tampering, modification of the product as originally manufactured by Winegard in any manner whatsoever, removing or defacing any serial number, usage not in accordance with product instructions or acts of nature such as damage caused by wind, lightning, ice or corrosive environments such as salt spray and acid rain. This Limited Warranty also does not apply if the product becomes unable to perform its' intended function in any way as a result of the television signal provider making any changes in technology or service.

RETURN AUTHORIZATION POLICY

A Return Material Authorization (RMA) is required prior to returning any product to Winegard Company or Winegard Warranty Services under this warranty policy. Please call our Technical Services Department at 800-788-4417 or send an e-mail to warranty@winegard.com to obtain the RMA number. Please furnish the date of purchase when requesting an RMA number. Enclose the product in a prepaid package and write the RMA number in large, clear letters on the outside of the package. To avoid confusion or misunderstanding, a shipment(s) without an RMA number(s) or an unauthorized return(s) will be refused and returned to Customer freight collect.

WINEGARD COMPANY DOES NOT ASSUME ANY LIABILITIES FOR ANY OTHER WARRANTIES, EXPRESS OR IMPLIED, MADE BY ANY OTHER PERSON. ALL OTHER WARRANTIES WHETHER EXPRESS, IMPLIED OR STATUTORY INCLUDING WARRANTIES OF FITNESS FOR A PARTICULAR PURPOSE AND MERCHANTABILITY ARE LIMITED TO THE TWO YEAR PERIOD OF THIS WARRANTY.

In states that do not allow limitations on implied warranties, or the exclusion of limitation of incidental or consequential damages, the above limitations or exclusions do not apply.

Some states do not allow limitations on how long an implied warranty lasts, or the exclusion of limitation of incidental or consequential damages, so the above limitations or exclusions may not apply to you.

This warranty gives Customer specific legal rights. Customer may also have other rights that may vary from state to state.

SATELLITE RECEIVER WARRANTY

See manufacturer's limited warranty policy.

**WS-MOBWARREV2
Rev. 1/10**

Free Manuals Download Website

<http://myh66.com>

<http://usermanuals.us>

<http://www.somanuals.com>

<http://www.4manuals.cc>

<http://www.manual-lib.com>

<http://www.404manual.com>

<http://www.luxmanual.com>

<http://aubethermostatmanual.com>

Golf course search by state

<http://golfingnear.com>

Email search by domain

<http://emailbydomain.com>

Auto manuals search

<http://auto.somanuals.com>

TV manuals search

<http://tv.somanuals.com>