

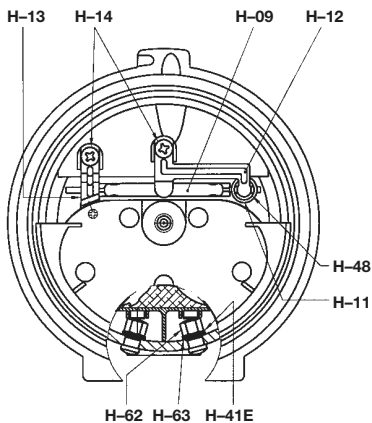

'Wolfrite' Safety Handlamp H-251E & H-251 Mk1 & Mk2 Operation & Maintenance Instructions

Wolfrite
Safety
Handlamp
H-251E

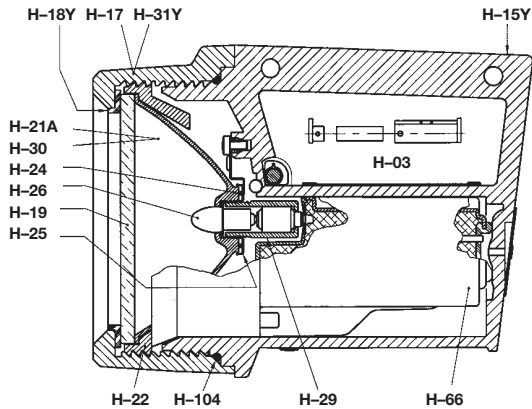



'Wolflite' Safety Handlamp H-251E & H-251 Mk1 & Mk2

Operation & Maintenance Instructions

Wolflite
Safety
Handlamp
H-251 Mk2

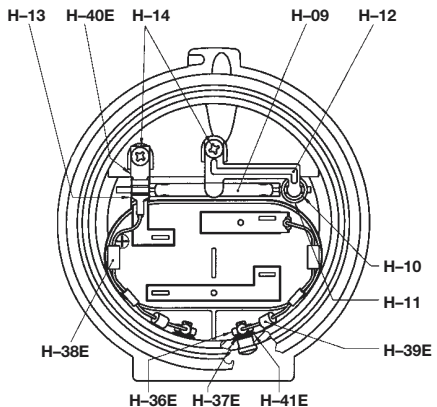
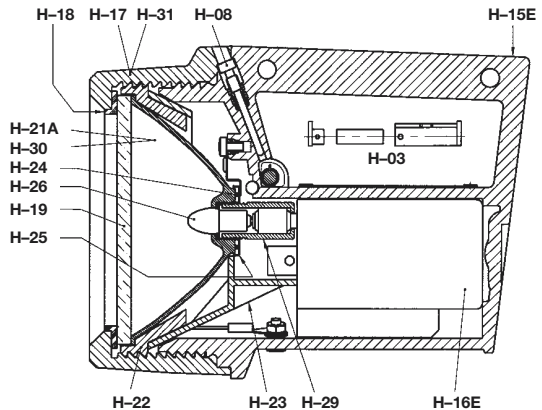

'Wolfite' H-251 Rechargeable Safety Handlamp Range

Operation & Maintenance Instructions

Certification

H-251E



EEx e ib IIC T4

Certificate: BASEEFA Ex 843292

H-251 Mk1 & Mk2



EEx e s II T3

Certificate: BASEEFA Ex 81142



Certificate: 86/00097

Use of Wolfite Handlamps in Hazardous Areas

- The **H-251E** Handlamp is certified for use in potentially explosive **gases, vapours and mists**. Applicable standards: EN50014:1977, EN50019:1977, EN50020:1977.
- The **H-251 Mk1/Mk2** Handlamps are certified for use in potentially explosive gases and vapours. Applicable standards: EN50014:1977, EN50019:1977, SFA 3009:1972.
- Ingress protection level for **H-251E** and **H-251 Mk1**: IP66, to EN60529:1992 for **H-251 Mk2**: IP54 to EN60529:1992.
- Users are advised to consult BS 5345: Part 1:1989 'Code of Practice for the Selection, Installation and Maintenance of Electrical Apparatus for use in Potentially Explosive Atmospheres' or National equivalent.
- The lamp must not be opened or fitted with replacement parts in a hazardous area. Lamp chargers must be kept and operated in non hazardous areas and in clean and dry conditions; a damaged lamp should be carefully examined for its continued safety. If in doubt, it should be withdrawn from use and returned to the manufacturer for repair.
- The 'Wolfite' Handlamp may constitute a static hazard and should be cleaned only with a damp cloth.
- Heavily soiled lamps must not be immersed in water or exposed to high pressure water jets for cleaning.
- Maintenance and repair must be carried out by a competent technician/electrician familiar with Certified Electrical Apparatus and in accordance with these maintenance instructions, using factory supplied spare parts only.
- **Handlamp operating ambient in Hazardous Areas: -20°C to +40°C**

Before Use

Charge battery before first use. To prevent accidental discharge of the battery in transit, the switch is locked in the OFF position.

To Lock/Unlock the Lamp (H-251 Mk1 & Mk2 only)

The stainless steel lock screw in front of the handle interlocks with the operating switch. Screw anti-clockwise to lock the lamp enclosure and release the operating switch. The lock key provided must be kept in a non-hazardous area.

WARNING: The Lock Screw bush can be dislodged if overtightened. Switch 'OFF' before screwing the Lock Screw down.

To Operate and Dismantle the Switch

The switch operates transversely, as indicated on the approval label. It consists of a magnet, a plastic housing and a cap. To replace, the old cap is prised off and the housing removed. The new switch housing/magnet is fitted to the body before the cap is 'snapped' in place.

To Open the Lamp

Unlock as above, unscrew the lens ring from the body to gain access to all internal parts.

To Replace the Bulb

The bulb (3.6 Volts, 1.0 Amp) is retained by the screwed centre contact at the back of the reflector.

To Replace the Glass Disc and/or Reflector

The toughened glass disc and reflector are secured in the lens ring by the reflector retaining ring. The battery retainer (H-251 Mk1/ Mk2 only) is 'snap' fitted in the lens ring, remove before unscrewing the reflector retaining ring. All parts must be cleaned and the rubber washer centralised before re-assembly. A key is available for fastening/unfastening this assembly.

To Replace Fuse and/or Reed Switch

The fuse contact must be removed to replace the fuse (Shorting Link in H-251E). To replace the reed switch, the battery contact and fuse contact must be removed.

To Replace the Battery for the H-251 Mk2

The positive and negative diode leads are disconnected from their respective terminals and the battery pack is removed from the body cavity.

To Replace the Battery for the H-251E

All connections are automatically made when the H-251E battery pack is replaced. The battery pack is a slide fit in the body cavity, clean the new battery pack and spring contacts prior to fitting. The H-251E battery pack is deep discharge protected, it will switch off after approximately four hours duration, preventing damage to the battery.

The Battery

A Lead Acid cell system is used in all 'Wolfliite' Safety Handlamps. A minimum of four hours continuous output is provided for an average of 500 recharging cycles. A common battery pack is used for the H-251 Mk1 and H-251 Mk2. The H-251E battery pack has an encapsulated control and current limiting circuit, and has been tested for EMC compliance and CE marked accordingly. For optimum performance and safety please observe the following:

- Charge before first use.
- Avoid deep discharge.
- Recharge immediately when flat.
- Recharge every six months when stored.

Note: **Dangerous Goods Regulations**
 Hazardous Materials Regulations
 Restricted Articles Regulations

The US Dept. of Transport, IATA, and CAA declare these batteries are "not regulated".

Warning: **Do not short-circuit or incinerate**
 Do not recharge other than from Wolf Chargers

Do not cut, crush or puncture
Dispose of only via licensed disposal agency

Charging 'Wolfliite' H-251 Mk1 Battery

To remove the battery for charging remove the lens ring (see "To Open the Lamp"). The battery removal tab is visible and can be used to aid extraction. WHILE THE BATTERY IS ON CHARGE THE LENS RING MUST BE REPLACED TO PREVENT DUST ENTERING THE LAMP ENCLOSURE. If available, a spare charged battery can be fitted.

The Battery is charged in a fully automatic charging unit. Indicators show when a battery has been fully charged. AFTER USE, RE-CHARGE AS SOON AS POSSIBLE.

Charger Unit C-251 for H-251 Mk1

This 'Wolfliite' Battery Charger is 'CE' marked as compliant with Low Voltage and EMC Directives. Before connecting to the mains ensure the correct voltage is selected and the battery is in the charger, the indicators will show the state of battery charge and charger mode. 90% capacity is achieved in 4/5 hours. The charger indicators will suffer from electro-magnetic interference when sited less than five metres from sources emitting at the following frequencies: 103-115MHz, 117-119MHz, 126-136MHz.

Charging 'Wolfliite' Handlamps H-251 Mk2 and H-251E

The battery is charged **within the lamp body**. The H-251 Mk2 Handlamp switch must be in the 'OFF' position when on charge. The H-251E can be switched 'ON' when charging, the lamp is then set for stand-by power failure mode and will automatically illuminate should power to the charger be cut. Indicators show the state of charge of the battery. Red only indicates the Lamp has not made correct contact, the Lamp must be pushed firmly until latched in position.

Lamp Chargers for H-251 Mk2 and H-251E

Two types of Lamp Chargers are available – HIGH VOLTAGE and LOW VOLTAGE, to suit fixed or mobile applications. The chargers are 'CE' marked as compliant with Low Voltage and EMC Directives.

Wolfliite Charger C-251HV is for mains AC input voltages of 200-240 volts at 50-60 Hz (Off-shore platform voltages of 254 volts at 60 Hz), user switchable to 100-120 volts at 50-60 Hz. Failure to select the correct voltage may cause damage. Charger achieves 90% recharge in 6/7 hours. Only fit manufacturer's specified fuse. Chargers are fitted with Approved plugs, refer to sales literature for details.

Wolfliite Charger C-251LV is suitable for use from DC supplies of 12 to 32 volts. A full recharge from a 12 volt supply takes 20/24 hours, but from a 24 volt supply 10/12 hours. The two-core flex is red, positive and black, negative.

Both chargers are fully automatic, stepping to a safe trickle charge level after the main charge is completed.

NOTE: A fully discharged battery must be charged immediately to avoid damage.
 The charger contacts are of low voltage output and short circuit protected.
 Charger operating ambient: +10°C to +25°C.

WARNING: THE WOLFILITE CHARGERS ARE DESIGNED FOR CHARGING WOLFLITE HANDLAMPS ONLY – NO OTHER BATTERIES OR BATTERY OPERATED DEVICES ARE TO BE USED

The Wolf Safety Lamp Co. Ltd. have a policy of continuous product review and improvement, and changes in design details whether permitted as Variations of Approvals or otherwise may be made without prior notice.



'Wolflite' Safety Handlamp H-251E & H-251 Mk1 & Mk2

Operation & Maintenance Instructions

Wolflite
Safety
Handlamp
H-251 Mk1

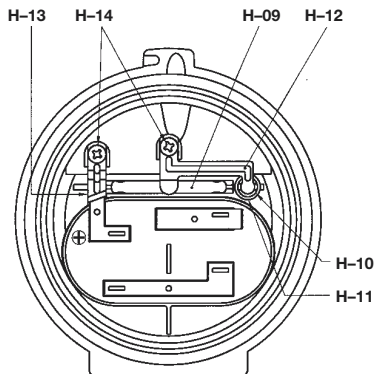
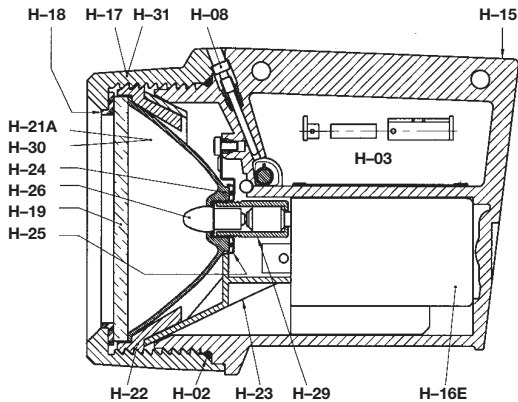

Spare Parts List for 'Wolfrite' Safety Handlamp

H-251E & H-251 Mk1 & Mk2

Description	H-251 Mk1	H-251 Mk2	H-251E
'O' ring seal	H-02	-	H-104
Magnet switch complete	H-03	H-03	H-03
Lock screw	H-08	H-08	H-08
Reed switch	H-09	H-09	H-09
Fuse for lamp, & link (H-251E)	H-10	H-10	H-48
Sleeve for fuse holder	H-11	H-11	H-11
Fuse contact	H-12	H-12	H-12
Battery contact	H-13	H-13	H-13
Screw for contacts	H-14	H-14	H-14
Body complete	H-15	H-15E	H-15Y
Battery pack	H-16E	H-16E	H-66
Lens ring	H-17	H-17	H-17
Rubber washer for glass disc	H-18	H-18	H-18Y
Glass disc	H-19	H-19	H-19
Reflector	H-21A	H-21A	H-21A
Reflector retaining ring	H-22	H-22	H-22
Battery retainer	H-23	H-23	-
Reflector distance piece	H-24	H-24	H-24
Bulb socket	H-25	H-25	H-25
Bulb 3.6v 1.0A Krypton (4 hrs.)	H-26	H-26	H-26
Bulb 4.8v 0.5A Krypton (8 hrs.)	H-26K	H-26K	H-26K
Centre contact complete	H-29	H-29	H-29
Reflector c/w bulb and fittings	H-30	H-30	H-30
Lens ring complete	H-31	H-31	H-31Y
Hexagon lock key 4 mm	H-33	H-33	H-33
Key for reflector retaining ring	H-34	H-34	H-34
Lanyard and fittings	H-35	H-35	H-35B
Nut for contact stud	-	H-36E	H-62
Spring washer for nut	-	H-37E	-
Diode lead (positive)	-	H-38E	-
Diode lead (negative)	-	H-39E	-
Terminal tab	-	H-40E	-
Support washer	-	H-41E	H-41E
Handlamp wall holder	H-58	H-58	H-58
Stud seal	-	-	H-63
	C-251	C-251HV	C-251LV
Clip for LV charger	-	-	C-57
Rocker switch for charger	C-62	-	-
Transformer 9v, 20vA	C-63	-	-
Printed circuit board	C-69	-	-
Lamp charger contacts	-	C-71	C-71
PCB for LV DC charger	-	-	C-81
Rocker switch for HV charger	-	C-82	-
PCB for HV charger	-	C-84	-
Washer for clip	-	-	T-2056
Rivet for clip	-	-	T-2057
Support spring	-	C-6021	C-6021
Fuse for charger	H-10	H-10	-

WOLF SAFETY LAMP COMPANY
Saxon Road Works, Sheffield S8 0YA, England
Tel: +44 114 255 1051 Fax: +44 114 255 7988
E-mail: info@wolf-safety.co.uk
Website: www.wolf-safety.co.uk



Free Manuals Download Website

<http://myh66.com>

<http://usermanuals.us>

<http://www.somanuals.com>

<http://www.4manuals.cc>

<http://www.manual-lib.com>

<http://www.404manual.com>

<http://www.luxmanual.com>

<http://aubethermostatmanual.com>

Golf course search by state

<http://golfingnear.com>

Email search by domain

<http://emailbydomain.com>

Auto manuals search

<http://auto.somanuals.com>

TV manuals search

<http://tv.somanuals.com>