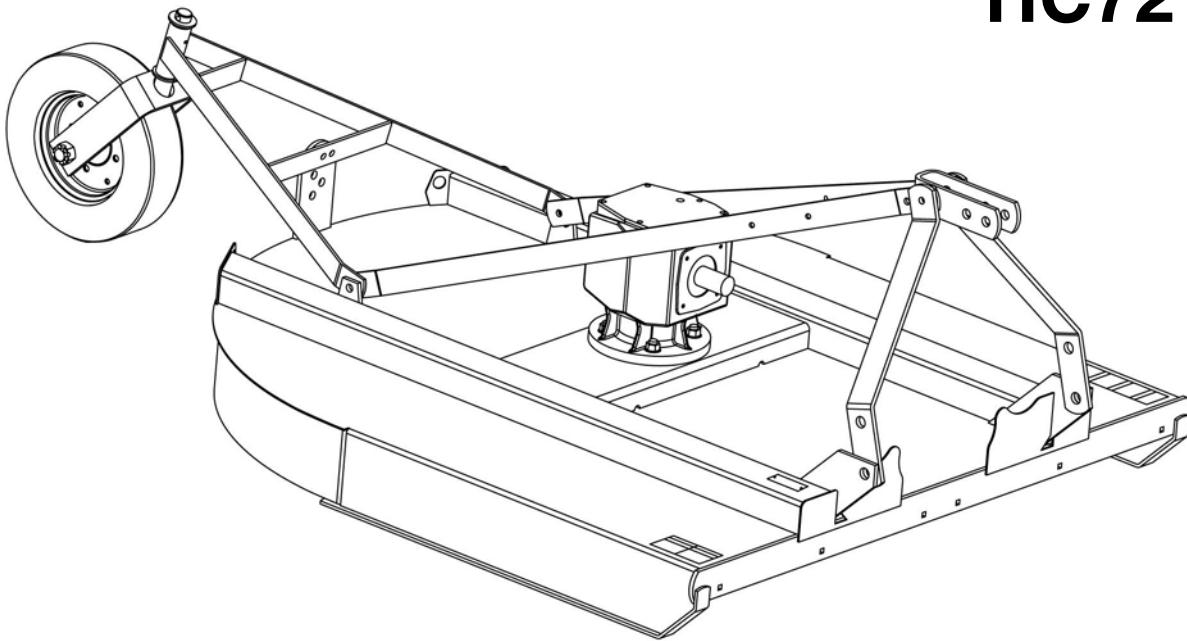


# WOODS HERITAGE™ ROTARY CUTTER

HC48  
HC54  
HC60  
HC72



**MAN0670**  
(Rev. 8/29/2011)

**WOODS®**

OPERATOR'S MANUAL

## TO THE DEALER:

Assembly and proper installation of this product is the responsibility of the Woods® dealer. Read manual instructions and safety rules. Make sure all items on the Dealer's Pre-Delivery and Delivery Check Lists in the Operator's Manual are completed before releasing equipment to the owner.

**The dealer must complete the online Product Registration form at the Woods Dealer Website** which certifies that all Dealer Check List items have been completed. Please contact your dealer to complete this form. Dealers can register all Woods product at dealer.WoodsEquipment.com under Product Registration.

**Failure to register the product does not diminish customer's warranty rights.**

## TO THE OWNER:

Read this manual before operating your Woods equipment. The information presented will prepare you to do a better and safer job. Keep this manual handy for ready reference. Require all operators to read this manual carefully and become acquainted with all adjustment and operating procedures before attempting to operate. Replacement manuals can be obtained from your dealer. To locate your nearest dealer, check the Dealer Locator at [www.WoodsEquipment.com](http://www.WoodsEquipment.com), or in the United States and Canada call 1-800-319-6637.

The equipment you have purchased has been carefully engineered and manufactured to provide dependable and satisfactory use. Like all mechanical products, it will require cleaning and upkeep. Lubricate the unit as specified. Observe all safety information in this manual and safety decals on the equipment.

For service, your authorized Woods dealer has trained mechanics, genuine Woods service parts, and the necessary tools and equipment to handle all your needs.

Use only genuine Woods service parts. Substitute parts will void the warranty and may not meet standards required for safe and satisfactory operation. Record the model number and serial number of your equipment in the spaces provided:

**Model:** \_\_\_\_\_ **Date of Purchase:** \_\_\_\_\_

**Serial Number: (see Safety Decal section for location)** \_\_\_\_\_

Provide this information to your dealer to obtain correct repair parts.

Throughout this manual, the term **NOTICE** is used to indicate that failure to observe can cause damage to equipment. The terms **CAUTION**, **WARNING**, and **DANGER** are used in conjunction with the Safety-Alert Symbol (a triangle with an exclamation mark) to indicate the degree of hazard for items of personal safety.



This is the safety alert symbol. It is used to alert you to potential personal injury hazards. Obey all safety messages that follow this symbol to avoid possible injury or death.



Indicates a hazardous situation which, if not avoided, will result in death or serious injury.



Indicates a hazardous situation which, if not avoided, could result in death or serious injury.



Indicates a hazardous situation which, if not avoided, could result in minor or moderate injury.

**IMPORTANT  
or NOTICE**

Is used to address practices not related to personal injury.

**NOTE**

Indicates helpful information.

**WOODS®**

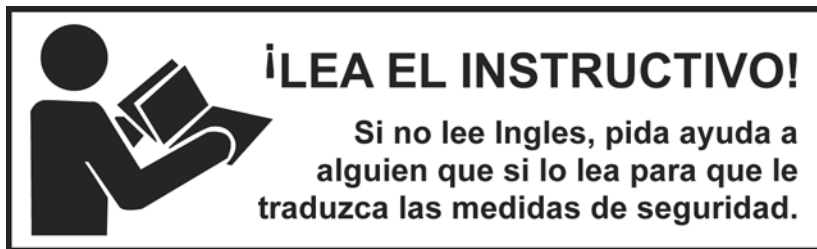
**ALITEC™**  
**BMP®**  
**CENTRAL FABRICATORS®**  
**GANNON®**  
**GILL®**  
**WAIN-ROY®**  
**WOODS®**

## 2 Introduction

Gen'l (Rev. 3/5/2010)

# TABLE OF CONTENTS

INTRODUCTION.....	2
SPECIFICATIONS.....	4
GENERAL INFORMATION.....	4
SAFETY VIDEO ORDER FORM.....	6
SAFETY RULES.....	7-9
SAFETY DECALS.....	10-11
OPERATION.....	12
OWNER SERVICE.....	18
TROUBLESHOOTING.....	22
DEALER SERVICE.....	23
ASSEMBLY INSTRUCTIONS.....	31
DEALER CHECK LISTS.....	34
INDEX TO PARTS LISTS.....	35
BOLT TORQUE CHART.....	47
BOLT SIZE CHART & ABBREVIATIONS.....	48
INDEX.....	49
PRODUCT WARRANTY.....	51
REPLACEMENT PARTS WARRANTY.....	52



**This Operator's Manual should be regarded as part of the machine. Suppliers of both new and second-hand machines must make sure that this manual is provided with the machine.**

# SPECIFICATIONS

3-Point Hitch: HC48, HC54, HC60, HC72 .....	Category 1 & 2
Cutting Height .....	1" - 9"
Blade Spindle .....	1
Number of Blades .....	2
Blades .....	Heat Treated Alloy Steel
Blade Rotation .....	CCW
Tractor PTO RPM .....	540
Universal Drive .....	Category 3
Side Frame Thickness .....	11 Ga
Tailwheel .....	4" x 16"

	<u>HC48</u>	<u>HC54</u>	<u>HC60</u>	<u>HC72</u>
Cutting Width	48"	54"	60"	72"
Overall Width	52"	58"	64"	76"
Weight (Approximate) w/Shear Bolt	428 lbs	474 lbs	538 lbs	604 lbs
Weight (Approximate) w/Slip Clutch	439 lbs	485 lbs	549 lbs	615 lbs
Blade Speed (Feet per minute)	13,028	14,657	14,335	14,963
Gearbox	1:1.92	1:1.92	1:1.69	1:1.47
Recommended Maximum Tractor HP	15 - 40	15 - 40	20 - 50	20 - 50

## GENERAL INFORMATION

**WARNING**

■ **Some illustrations in this manual show the equipment with safety shields removed to provide a better view. This equipment should never be operated with any necessary safety shielding removed.**

The purpose of this manual is to assist you in operating and maintaining your cutter. Read it carefully. It furnishes information and instructions that will help you achieve years of dependable performance. These instructions have been compiled from extensive field experience and engineering data. Some information may be general in nature due to unknown and varying

operating conditions. However, through experience and these instructions, you should be able to develop procedures suitable to your particular situation.

The illustrations and data used in this manual were current at the time of printing, but due to possible inline production changes, your machine may vary slightly in detail. We reserve the right to redesign and change the machines as may be necessary without notification.

Throughout this manual, references are made to right and left directions. These are determined by standing behind the equipment, facing the direction of forward travel. Blade rotation is counterclockwise as viewed from the top of the cutter.

**BE SAFE!**

**BE ALERT!**

**BE ALIVE!**

**BE TRAINED**

**Before Operating Mowers!**



ASSOCIATION OF  
EQUIPMENT  
MANUFACTURERS

*Safety Training  
Does Make a Difference.*

---

## **Free Mower Safety Video**

Fill out and return the order form and we will send you a FREE VHS or DVD video outlining ***Industrial and Agricultural Mower Safety Practices***. The 22 minute video, developed in cooperation with AEM (Association of Equipment Manufacturers), reinforces the proper procedures to follow while operating your mowing equipment. The video does not replace the information contained in the Operator's Manual, so please review this manual thoroughly before operating your new mowing equipment.

**Also, available from the Association of Equipment Manufacturers:**

A large variety of training materials (ideal for groups) are available for a nominal charge from AEM. Following is a partial list:

- **Training Package for Rotary Mowers/Cutters-English**  
Contains: DVD & VHS (English)  
    Guidebook for Rotary Mowers/Cutters (English)  
    AEM Industrial/Agricultural Mower Safety Manual (English)  
    AEM Agricultural Tractor Safety Manual (English)
- **Training Package for Rotary Mowers/Cutters-English/Spanish**  
Contains: DVD & VHS (English/Spanish)  
    Guidebook for Rotary Mowers/Cutters (English/Spanish)  
    AEM Industrial/Agricultural Mower Safety Manual (English/Spanish)  
    AEM Agricultural Tractor Safety Manual (English/Spanish)

AEM training packages are available through:

AEM at: [www.aem.org](http://www.aem.org)

or

Universal Lithographers, Inc.

Email: [aem@ulilitho.com](mailto:aem@ulilitho.com)

800-369-2310 tel

866-541-1668 fax



---

## Free Mower/Cutter Safety Video Order Form

Please send me  (Select one)  
 **VHS** Format - VHS01052 Safety Video  
 **DVD** Format - DVD01052 Safety Video

Name: \_\_\_\_\_ Phone: \_\_\_\_\_

Address: \_\_\_\_\_  
\_\_\_\_\_  
\_\_\_\_\_

Mower/Cutter Model: \_\_\_\_\_ Serial #: \_\_\_\_\_

Send to:     ATTENTION: DEALER SERVICES  
              **WOODS EQUIPMENT COMPANY**  
              PO BOX 1000  
              OREGON IL 61061-1000  
              USA

# SAFETY RULES



**ATTENTION! BECOME ALERT! YOUR SAFETY IS INVOLVED!**



Safety is a primary concern in the design and manufacture of our products. Unfortunately, our efforts to provide safe equipment can be wiped out by an operator's single careless act.

In addition to the design and configuration of equipment, hazard control and accident prevention are dependent upon the awareness, concern, judgement, and proper training of personnel involved in the operation, transport, maintenance, and storage of equipment.

It has been said, "The best safety device is an informed, careful operator." We ask you to be that kind of operator.

## **TRAINING**

- **Safety instructions are important! Read all attachment and power unit manuals; follow all safety rules and safety decal information. (Replacement manuals and safety decals are available from your dealer. To locate your nearest dealer, check the Dealer Locator at [www.WoodsEquipment.com](http://www.WoodsEquipment.com), or in the United States and Canada call 1-800-319-6637.) Failure to follow instructions or safety rules can result in serious injury or death.**
- **If you do not understand any part of this manual and need assistance, see your dealer.**
- **Know your controls and how to stop engine and attachment quickly in an emergency.**
- **Operators must be instructed in and be capable of the safe operation of the equipment, its attachments, and all controls. Do not allow anyone to operate this equipment without proper instructions.**
- **Never allow children or untrained persons to operate equipment.**

## **PREPARATION**

- **Check that all hardware is properly installed. Always tighten to torque chart specifications unless instructed otherwise in this manual.**
- **Always wear relatively tight and belted clothing to avoid getting caught in moving parts. Wear sturdy, rough-soled work shoes and protective equipment for eyes, hair, hands, hearing, and head; and respirator or filter mask where appropriate.**
- **Make sure attachment is properly secured, adjusted, and in good operating condition.**

- **Make sure spring-activated locking pin or collar slides freely and is seated firmly in tractor PTO spline groove.**

- **Before starting power unit, check all equipment driveline guards for damage. Replace any damaged guards. Make sure all guards rotate freely on all drivelines. If guards do not rotate freely on drivelines, repair and replace bearings before putting equipment into service.**

- **Power unit must be equipped with ROPS or ROPS cab and seat belt. Keep seat belt securely fastened. Falling off power unit can result in death from being run over or crushed. Keep foldable ROPS system in "locked up" position at all times.**

- **Inspect chain, rubber, or steel band shielding before each use. Replace if damaged.**

- **Remove accumulated debris from this equipment, power unit, and engine to avoid fire hazard.**

- **Make sure all safety decals are installed. Replace if damaged. (See Safety Decals section for location.)**

- **Make sure shields and guards are properly installed and in good condition. Replace if damaged.**

- **A minimum 20% of tractor and equipment weight must be on the tractor front wheels when attachments are in transport position. Without this weight, front tractor wheels could raise up resulting in loss of steering. The weight may be attained with front wheel weights, ballast in tires or front tractor weights. Weigh the tractor and equipment. Do not estimate.**

- **Inspect and clear area of stones, branches, or other hard objects that might be thrown, causing injury or damage.**

## **OPERATION**

- **Do not allow bystanders in the area when operating, attaching, removing, assembling, or servicing equipment.**

*(Safety Rules continued on next page)*



# SAFETY RULES

**ATTENTION! BECOME ALERT! YOUR SAFETY IS INVOLVED!**



*(Safety Rules continued from previous page)*

■ Full chain, rubber, or steel band shielding must be installed when operating in populated areas or other areas where thrown objects could injure people or damage property.

- If this machine is not equipped with full chain, rubber, or steel band shielding, operation must be stopped when anyone comes within 300 feet (92 m).
- This shielding is designed to reduce the risk of thrown objects. The mower deck and protective devices cannot prevent all objects from escaping the blade enclosure in every mowing condition. It is possible for objects to ricochet and escape, traveling as much as 300 feet (92 m).

- Never direct discharge toward people, animals, or property.
- Do not operate or transport equipment while under the influence of alcohol or drugs.
- Operate only in daylight or good artificial light.
- Keep hands, feet, hair, and clothing away from equipment while engine is running. Stay clear of all moving parts.
- Always comply with all state and local lighting and marking requirements.
- Never allow riders on power unit or attachment.
- Power unit must be equipped with ROPS or ROPS cab and seat belt. Keep seat belt securely fastened. Falling off power unit can result in death from being run over or crushed. Keep foldable ROPS system in “locked up” position at all times.
- Always sit in power unit seat when operating controls or starting engine. Securely fasten seat belt, place transmission in neutral, engage brake, and ensure all other controls are disengaged before starting power unit engine.
- Operate tractor PTO at 540 RPM. Do not exceed.
- Do not operate PTO during transport.
- Look down and to the rear and make sure area is clear before operating in reverse.
- Do not operate or transport on steep slopes.
- Do not stop, start, or change directions suddenly on slopes.
- Use extreme care and reduce ground speed on slopes and rough terrain.
- Watch for hidden hazards on the terrain during operation.

■ Stop power unit and equipment immediately upon striking an obstruction. Turn off engine, remove key, inspect, and repair any damage before resuming operation.

■ Leak down or failure of mechanical or hydraulic system can cause equipment to drop.

■ Before performing any service or maintenance, disconnect driveline from tractor PTO.

## MAINTENANCE

■ Before performing any service or maintenance, disconnect driveline from tractor PTO.

■ Before working underneath, disconnect driveline, raise cutter, and block cutter securely. Hydraulic system leak down and failure of mechanical or hydraulic system can cause equipment to drop.

■ Do not modify or alter or permit anyone else to modify or alter the equipment or any of its components in any way.

■ Always wear relatively tight and belted clothing to avoid getting caught in moving parts. Wear sturdy, rough-soled work shoes and protective equipment for eyes, hair, hands, hearing, and head; and respirator or filter mask where appropriate.

■ Make sure attachment is properly secured, adjusted, and in good operating condition.

■ Do not allow bystanders in the area when operating, attaching, removing, assembling, or servicing equipment.

■ Keep all persons away from operator control area while performing adjustments, service, or maintenance.

■ Make certain all movement of equipment components has stopped before approaching for service.

■ Frequently check blades. They should be sharp, free of nicks and cracks, and securely fastened.

■ Do not handle blades with bare hands. Careless or improper handling may result in serious injury.

■ Your dealer can supply genuine replacement blades. Substitute blades may not meet original equipment specifications and may be dangerous.

■ Tighten all bolts, nuts, and screws to torque chart specifications. Check that all cotter pins are



# SAFETY RULES



**ATTENTION! BECOME ALERT! YOUR SAFETY IS INVOLVED!**



installed securely to ensure equipment is in a safe condition before putting unit into service.

- Make sure all safety decals are installed. Replace if damaged. (See Safety Decals section for location.)
- Make sure shields and guards are properly installed and in good condition. Replace if damaged.

## STORAGE

- Keep children and bystanders away from storage area.
- Disconnect cutter driveshaft and secure up off ground. Raise cutter with 3-point hitch. Place blocks under cutter side skids. Lower cutter onto blocks. Disconnect cutter from tractor 3-point hitch and carefully drive tractor away from cutter.



# SAFETY & INSTRUCTIONAL DECALS



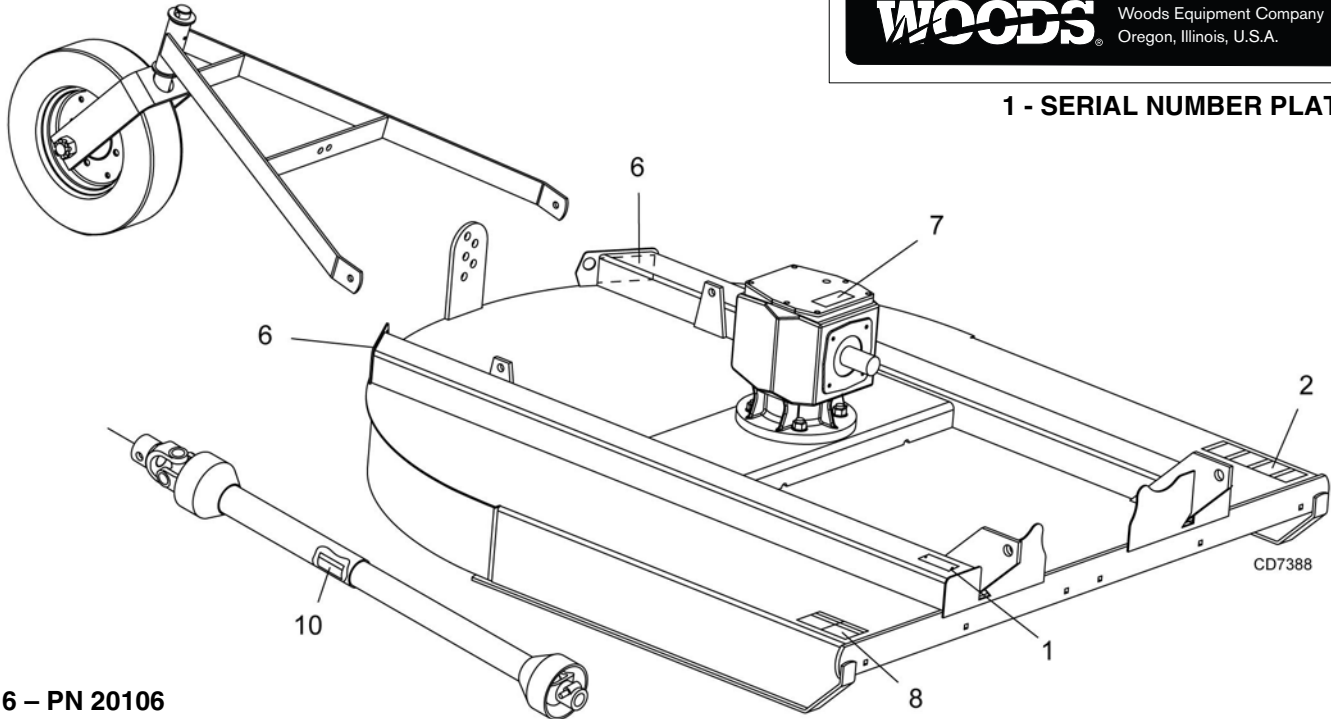
**ATTENTION! BECOME ALERT! YOUR SAFETY IS INVOLVED!**



**Replace Immediately If Damaged!**



**1 - SERIAL NUMBER PLATE**



**6 - PN 20106  
RED REAR REFLECTOR 4.5"**

**8 - PN 1006682**

<b>! DANGER</b>			
<b>ROTATING BLADES AND THROWN OBJECTS</b>			
<ul style="list-style-type: none"> <li>■ Do not put hands or feet under or into mower when engine is running.</li> <li>■ Before mowing, clear area of objects that may be thrown by blade.</li> <li>■ Keep bystanders away.</li> <li>■ Keep guards in place and in good condition.</li> </ul> <p style="text-align: center;"><b>BLADE CONTACT OR THROWN OBJECTS CAN CAUSE SERIOUS INJURY OR DEATH.</b></p>			

<b>! DANGER</b>
<b>ROTATING DRIVELINE CONTACT CAN CAUSE DEATH KEEP AWAY!</b>
<p><b>DO NOT OPERATE WITHOUT -</b></p> <ul style="list-style-type: none"> <li>■ All driveline guards, tractor and equipment shields in place</li> <li>■ Drivelines securely attached at both ends</li> <li>■ Driveline guards that turn freely on driveline</li> </ul> <p style="text-align: right; font-size: small;">1006682-A</p>

# SAFETY & INSTRUCTIONAL DECALS



**ATTENTION! BECOME ALERT! YOUR SAFETY IS INVOLVED!**



**Replace Immediately If Damaged!**

**WARNING**

**CRUSHING AND PINCHING HAZARD**

- Be extremely careful handling various parts of the machine. They are heavy and hands, fingers, feet, and other body parts could be crushed or pinched between tractor and implement.
- Operate tractor controls from tractor seat only.
- Do not stand between tractor and implement when tractor is in gear.
- Make sure parking brake is engaged before going between tractor and implement.
- Stand clear of machine while in operation or when it is being raised or lowered.

FAILURE TO FOLLOW THESE INSTRUCTIONS COULD RESULT IN SERIOUS INJURY OR DEATH.

2 - PN 1006681

7 - PN 1004114

**DANGER**

If shaft connection is visible, shield is missing. Replace shield before operating equipment.

1004114

**WARNING**

**TO AVOID SERIOUS INJURY OR DEATH:**

- Read Operator's Manual (available from dealer) and follow all safety precautions.
- Keep all shields in place and in good condition.
- Operate mower from tractor seat only.
- Lower mower, stop engine and remove key before dismantling tractor.
- Allow no children or untrained persons to operate equipment.
- Do not transport towed or semi-mounted units over 20 mph.

FAILURE TO OPERATE SAFELY CAN RESULT IN INJURY OR DEATH.

10 - PN 33347

**DANGER**

**GUARD MISSING. DO NOT OPERATE.**

**DANGER**

**GUARD MISSING. DO NOT OPERATE.**

33347E

**DANGER**

**WARNING**

**FALLING OFF CAN RESULT IN BEING RUN OVER.**

- Tractor must be equipped with ROPS (or ROPS CAB) and seat belt. Keep foldable ROPS systems in "locked up" position at all times.
- Buckle Up! Keep seat belt securely fastened.
- Allow no riders.

**RAISED EQUIPMENT CAN DROP AND CRUSH.**

- Before working underneath, follow all instructions and safety rules in operator's manual and securely block up all corners of equipment with jack stands.
- Securely blocking prevents equipment from dropping from hydraulic leakdown, hydraulic system failures or mechanical component failures.

FALLING OFF OR FAILING TO BLOCK SECURELY CAN RESULT IN SERIOUS INJURY OR DEATH.

**BE CAREFUL!**

Use a clean, damp cloth to clean safety decals.

Avoid spraying too close to decals when using a pressure washer; high-pressure water can enter through very small scratches or under edges of decals causing them to peel or come off.

Replacement safety decals can be ordered free from your Woods dealer. To locate your nearest dealer, check the Dealer Locator at [www.WoodsEquipment.com](http://www.WoodsEquipment.com), or in the United States and Canada call 1-800-319-6637.

**WARNING**

**DO NOT EXCEED PTO SPEED OF 540 RPM**

PTO speeds higher than 540 RPM can cause equipment failure and personal injury.

1006681

# OPERATION

The operator is responsible for the safe operation of the cutter. The operator must be properly trained. Operators should be familiar with the cutter, the tractor, and all safety practices before starting operation. Read the safety rules and safety decals on page 7 through page 11. Be sure to complete the Pre-Operation check list on page 17 before operating this cutter.

This standard-duty cutter is designed for grass and weed mowing and shredding.

Recommended mowing speed for most conditions is from 2 to 5 mph.

## **⚠ DANGER**

■ Full chain, rubber, or steel band shielding must be installed when operating in populated areas or other areas where thrown objects could injure people or damage property.

- If this machine is not equipped with full chain, rubber, or steel band shielding, operation must be stopped when anyone comes within 300 feet (92 m).
- This shielding is designed to reduce the risk of thrown objects. The mower deck and protective devices cannot prevent all objects from escaping the blade enclosure in every mowing condition. It is possible for objects to ricochet and escape, traveling as much as 300 feet (92 m).

## **⚠ CAUTION**

■ Stop power unit and equipment immediately upon striking an obstruction. Turn off engine, remove key, inspect, and repair any damage before resuming operation.

■ Always wear relatively tight and belted clothing to avoid getting caught in moving parts. Wear sturdy, rough-soled work shoes and protective equipment for eyes, hair, hands, hearing, and head; and respirator or filter mask where appropriate.

## **TRACTOR STABILITY**

## **⚠ WARNING**

■ A minimum 20% of tractor and equipment weight must be on the tractor front wheels when attachments are in transport position. Without this weight, front tractor wheels could raise up resulting in loss of steering. The weight may be attained

with front wheel weights, ballast in tires or front tractor weights. Weigh the tractor and equipment. Do not estimate.

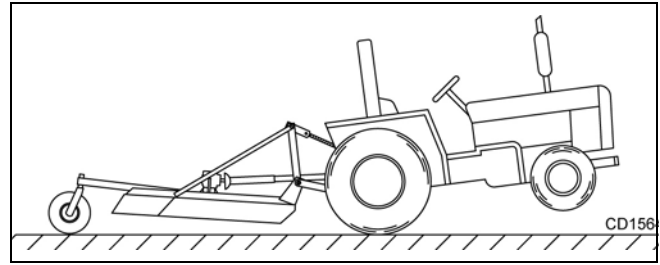


Figure 1. Tractor Stability

## **ATTACH CUTTER TO TRACTOR**

## **⚠ WARNING**

- Make sure spring-activated locking pin or collar slides freely and is seated firmly in tractor PTO spline groove.
- Keep bystanders away from equipment.
- Operate tractor PTO at 540 RPM. Do not exceed.

## **⚠ CAUTION**

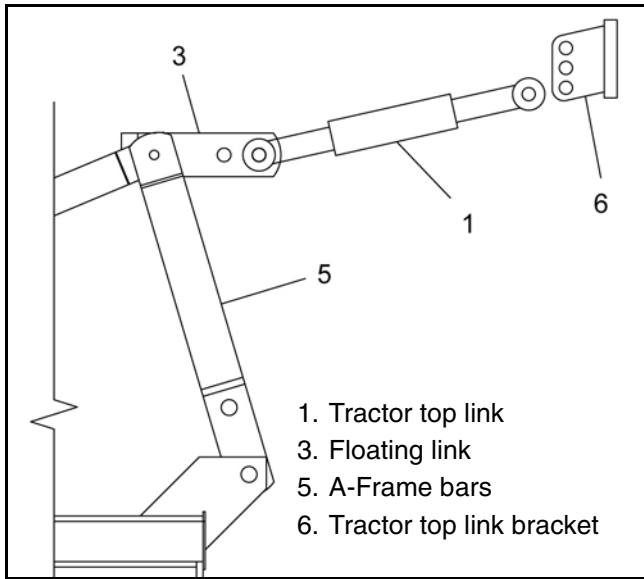
- Make sure driveline will not bottom out at the shortest length and that it has at least 1/3 overlap at the longest length.
- With cutter adjusted to transport position, set upper stop on tractor lift quadrant to prevent deck from hitting the driveline when being raised.
- Select a top link mounting pin (maximum length 3-5/8") that will allow floating link to swing freely through the cutter A-frame bars.

1. Attach tractor 3-point lift arms to the cutter hitch pins and secure.
2. Attach tractor top link to cutter clevis using forward hole. Select a top link mounting pin that will allow floating link to swing freely through the cutter A-frame bars.

**NOTE:** You will need to adjust the top link; refer to **Top Link Adjustment, page 13.**

3. Adjust the tractor lower 3-point arm anti-sway devices to prevent cutter from swinging side to side during transport.
4. Adjust tractor drawbar so that it will not interfere with cutter or driveline.

## Top Link Adjustment



**Figure 2.** Top Link Adjustment

1. Attach tractor top link (1) to lowest hole provided in the tractor's top link bracket (6).
2. Attach rear portion of tractor top link to the first hole on the cutter floating link (3). Select a top link mounting pin that will allow the floating link to swing freely through the cutter A-frame bars (5).
3. Raise cutter to transport position and adjust tractor top link until cutter is level in the raised position.

**NOTE:** If you cannot level the cutter using the lowest hole in the tractor's top link bracket, move top link to the next hole and level the cutter.

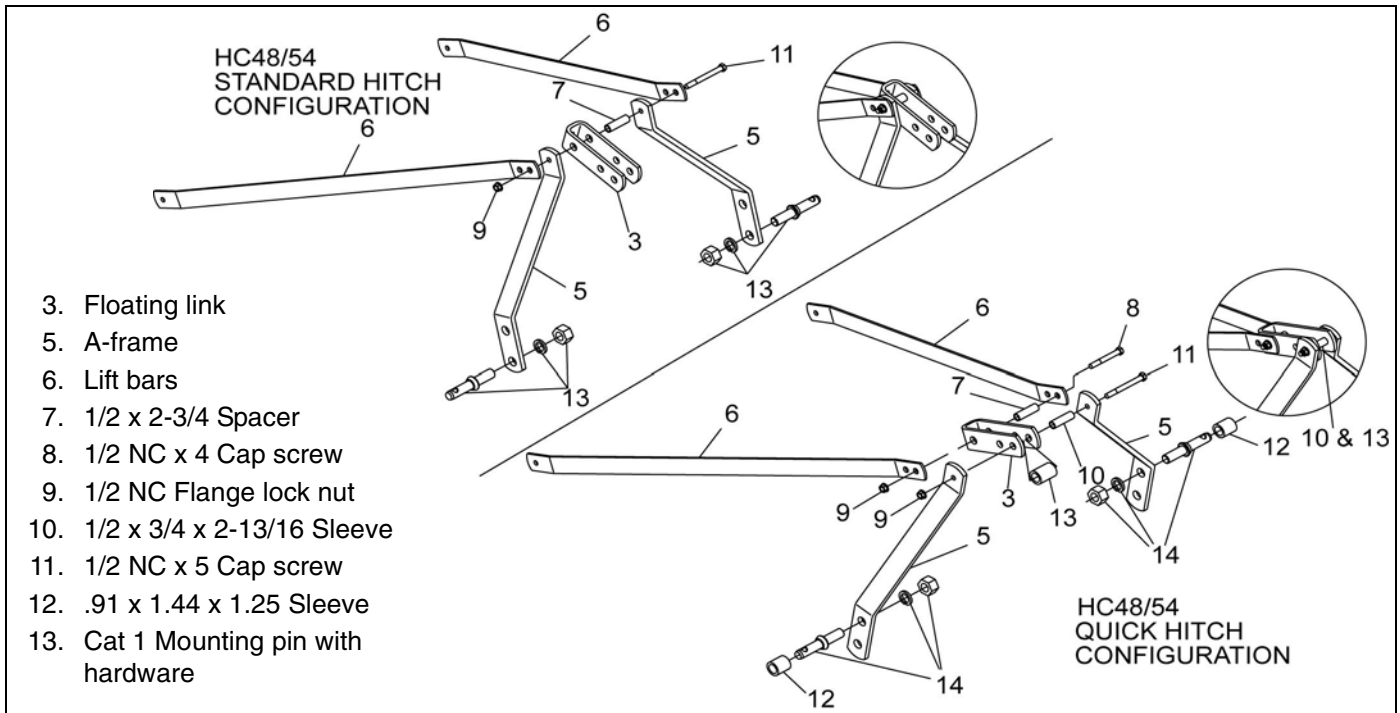
## QUICK HITCH ASSEMBLY (HC48 / HC54)

### Refer to Figure 3

1. Remove brace arms (6), floating link (3), cap screw (11), spacer (7), and flange lock nut (9) from hole on top of A-frame bars (5).
2. Remove hitch pins and place A-frame bars (5) in second holes. Install hitch pins and tighten at this time.
3. Attach open end of floating link (3) to hole in A-frame bars (5) and secure using cap screw (11), sleeve (10), and flange lock nut (9).
4. Attach closed end of floating link (3) to first hole in diagonal braces (6), use second hole for sub-compact tractors. Secure using cap screw (8), spacer (7), and flange lock nut (9) supplied in hardware bag. Tighten all hardware and hitch pins.

**NOTE:** Top hook on quick hitch will pick up on sleeve (10). Bottom quick hitch hooks will attach to cutter hitch pins. Category I hitch pins will require bushings (PN 38214) to be installed over hitch pins before connection to quick hitch.

5. Install sleeve (12) over hitch pins and secure with click pin before connecting to quick hitch.
6. Raise cutter to transport position and adjust tractor top link until cutter is level in the raised position.



**Figure 3.** Standard Hitch and Quick Hitch Configurations - HC48, HC54

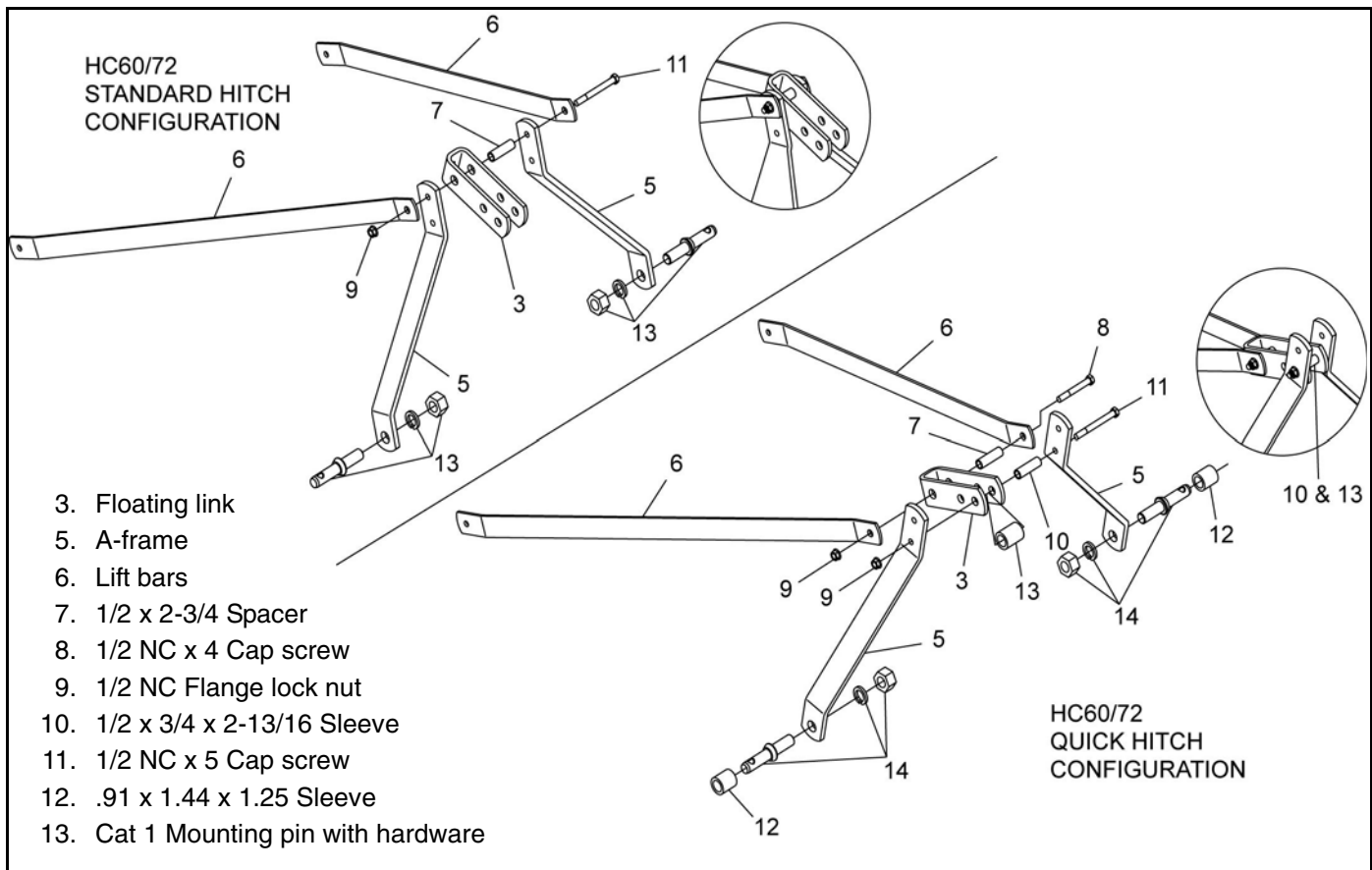


Figure 4. Standard Hitch and Quick Hitch Configurations - HC60, HC72

## QUICK HITCH ASSEMBLY (HC60 / HC72)

Refer to Figure 4.

1. Remove brace arms (6), floating link (3), cap screw (11), spacer (7), and flange lock nut (9) from upper hole on A-frame bars (5).
2. Remove hitch pins and place sleeves in hole of diagonal braces. Install hitch pins and tighten at this time.
3. Attach open end of floating link (3) to second hole on top of A-frame bars (5). Secure using cap screw (11), sleeve (10), and flange lock nut (9).
4. Attach closed end of floating link (3) to diagonal braces (6). Secure using cap screw (8), spacer (7), and flange lock nut (9) supplied in hardware bag. Tighten all hardware and hitch pins.

**NOTE:** Top hook on quick hitch will pick up on sleeve (10). Bottom quick hitch hooks will attach to cutter hitch pins. Category I hitch pins will require bushings (PN 38214) to be installed over hitch pins before connection to quick hitch.

5. Install sleeve (12) over hitch pins and secure with klik pin before connecting to quick hitch.

6. Raise cutter to transport position and adjust tractor top link until cutter is level in the raised position.

## ATTACH CUTTER TO TRACTOR

### **Standard Hitch**

1. Attach tractor 3-point arms to hitch pins and secure with klik pins.
2. Attach tractor top link to the floating link and adjust as necessary. See Top Link Adjustment, page 13.
3. Adjust the tractor lower 3-point arm anti-sway devices to prevent cutter from swinging side to side.

### **Quick Hitch**

1. Attach tractor 3-point arms to hitch pins and secure with klik pins.
2. Attach tractor with the quick hitch to the cutter and secure according to the quick hitch manufacturer's instructions. Adjust tractor top link as necessary. See Top Link Adjustment, page 13.
3. Adjust the tractor lower 3-point arm anti-sway devices to prevent cutter from swinging side to side.



## DRIVELINE INSTALLATION (TRACTOR PTO)

### **WARNING**

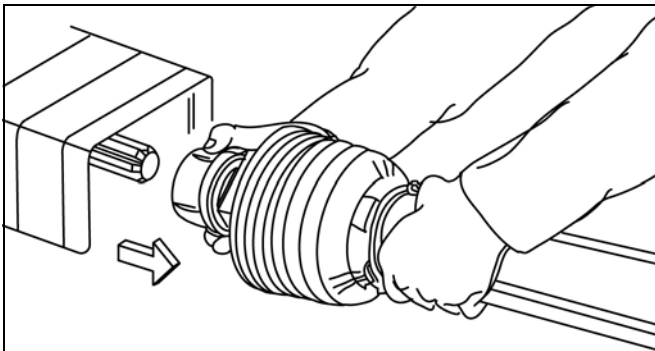
■ **Make sure spring-activated locking pin or collar slides freely and is seated firmly in tractor PTO spline groove.**

#### **To Install:**

Pull locking collar back and at the same time push the driveline onto tractor PTO shaft until locking device engages.

#### **To Remove:**

Hold driveline into position, pull locking collar back, and slide driveline off tractor PTO shaft.



**Figure 5.** Lock Collar

## DRIVELINE ADJUSTMENT

Attach the cutter to the tractor 3-point hitch (or quick hitch if available). Do not attach driveline. Raise and lower cutter to determine maximum and minimum distance between the tractor PTO shaft and the gearbox input shaft. If the distance is too large, the driveline will be too short for proper engagement. **If distance is too small, the driveline may bottom out in operation and damage the cutter or tractor.**

The driveline length must be sufficient to provide at least 1/3 driveline length of engagement during normal operation. There must be at least 4 inches of engagement at the cutter's lowest possible point of operation. Driveline must not bottom out when raised to the maximum height possible.

If driveline is too short, please call your Woods dealer for a longer driveline.

If driveline is too long, please follow the instructions for shortening the driveline.

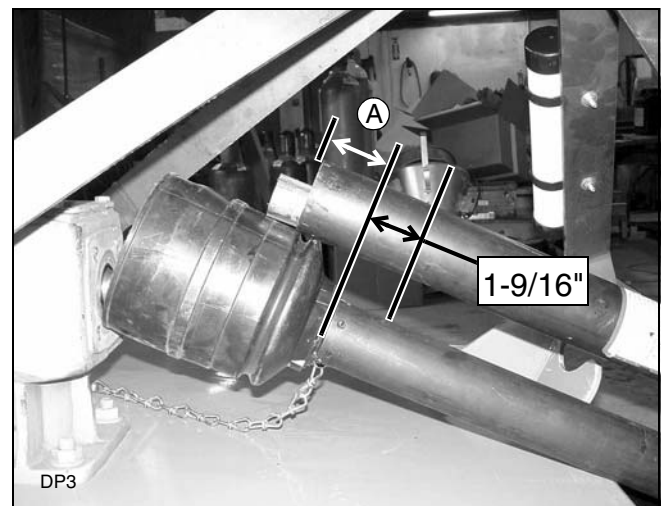
## SHORTEN DRIVELINE

1. Move cutter up and down to get the shortest possible distance between tractor PTO shaft and gearbox input shaft.
2. Separate driveline into two halves and connect them to the tractor PTO and gearbox.
3. Place driveline halves parallel to one another to determine how much to shorten the driveline.



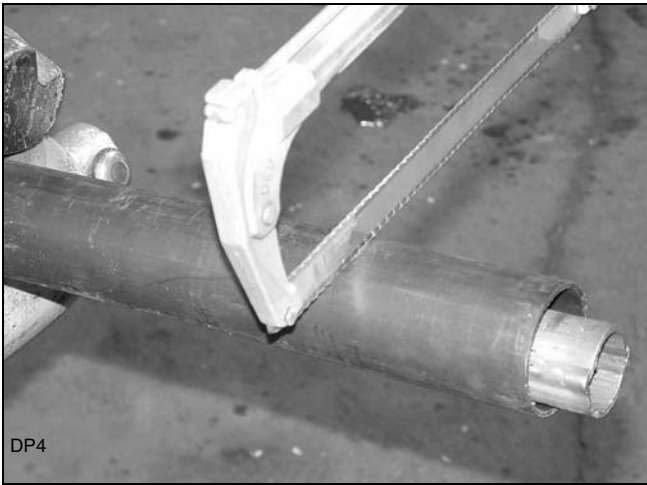
**Figure 6.** Drive Halves Placed Parallel

4. Measure from end of the upper shield to the base of the bell on the lower shield (A). Add 1-9/16" to dimension (A). See Figure 7.



**Figure 7.** Determine Shield Length

5. Cut the shield to the overall dimension.



**Figure 8.** Cut Shield

- Place the cutoff portion of the shield against the end of the shaft and use as a guide. Mark and cut the shaft.



**Figure 9.** Cut Shaft to Length

- Repeat step 6 for the other half of the drive.
- File and clean cut ends of both drive halves.

Do not use tractor if proper driveline engagement cannot be obtained through these methods.

Connect driveline to tractor PTO shaft, making sure the spring-activated locking collar slides freely and locks driveline to PTO shaft.

### **NOTICE**

■ If attaching with quick hitch, the distance between the tractor PTO and gearbox input shaft will increase. Please follow the steps as you would for a 3-point hitch to insure proper engagement.

### **DRIVELINE INTERFERENCE CHECK**

- Check for clearance between driveline and cutter deck.

- Slowly lift cutter and observe driveline. If clearance between driveline and cutter deck is less than 1 inch, shorten top link or limit upper travel of lower hitch arms. Refer to tractor operator's manual for instructions.

### **CUTTING HEIGHT ADJUSTMENT**

#### **⚠ WARNING**

■ Keep all persons away from operator control area while performing adjustments, service, or maintenance.

■ Avoid low cutting heights. Striking the ground with blades produces one of the most damaging shock loads a cutter can encounter. Allowing blades to contact ground repeatedly will cause damage to cutter and drive.

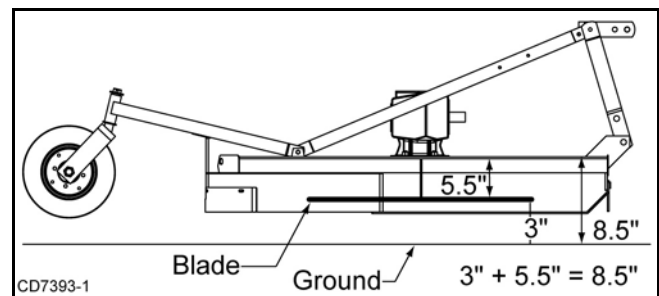
- Level cutter from side to side. Check by measuring from cutter frame to the ground at each deck rail.
- Adjust, using tractor 3-point arm leveling device.

**NOTE:** Keep the front of cutter slightly lower than rear for best mowing.

- Control cutting height with tractor 3-point arms, rear tailwheel adjustment.
- To raise rear of cutter, move tailwheel arm down.
- To raise front of cutter, raise tractor 3-point arms.

The cutting height is the distance between the blade and the ground. The blades are approximately 5.5" below the deck. To check cutting height, do the following:

- Place a straight edge along top edge of deck.
- Select a cutting height; as an example, for an approximate cutting height of 3", set the center of the deck 8.5" above the ground:
 
$$\begin{array}{r} 3" \text{ Desired cutting height} \\ + 5.5" \text{ Distance blade cutting edge is below deck} \\ \hline = 8.5" \text{ Distance from top of deck to the ground} \end{array}$$
- Adjust the front-to-rear attitude, the rear should be from 1/2" to 3/4" higher than the front.



**Figure 10.** Cutting Height Adjustment



## **SHREDDING MATERIAL**

For shredding, set the cutter lower at rear. Determine how much lower to set the rear by experimenting in different situations.

## **OPERATING TECHNIQUE**

1. Power for operating the cutter is supplied by the tractor PTO. Operate PTO at 540 rpm. Know how to stop the tractor and cutter quickly in an emergency.
2. Engage PTO at a low engine rpm to minimize stress on the drive system and gearbox. With PTO engaged, raise PTO speed to 540 rpm and maintain throughout cutting operation.

Gearbox protection is provided by a slip clutch with replacement fiber disc or a shear bolt. The slip clutch is designed to slip and the shear bolt will shear when excessive torsion loads occur.

3. Move slowly into material. Adjust tractor ground speed to provide a clean cut without lugging the tractor engine. Use a slow ground speed for better shredding.

Proper ground speed will depend on the terrain and the material's height, type, and density.

Normally, ground speed will range from 2 to 5 mph. Tall, dense material should be cut at a low speed; thin, medium-height material can be cut at a faster ground speed.

4. Always operate tractor PTO at 540 rpm to maintain proper blade speed and to produce a clean cut.
5. Under certain conditions tractor tires may roll down some grass and prevent cutting at the same height as the surrounding area. When this occurs, reduce your ground speed but maintain PTO at 540 rpm. The lower ground speed will permit grass to rebound partially.

## **STORAGE**



- **Disconnect cutter driveshaft and secure up off ground. Raise cutter with 3-point hitch. Place blocks under cutter side skids. Lower cutter onto blocks. Disconnect cutter from tractor 3-point hitch and carefully drive tractor away from cutter.**
- **Keep children and bystanders away from storage area.**

## **PRE-OPERATION CHECK LIST**

### OWNER'S RESPONSIBILITY

- \_\_\_ Review and follow all safety rules and safety decal instructions on page 7 through page 11.
- \_\_\_ Check that equipment is properly and securely attached to tractor.
- \_\_\_ Make sure driveline spring-activated locking pin or collar slides freely and is seated firmly in tractor PTO spline groove.
- \_\_\_ Set tractor PTO at 540 rpm.
- \_\_\_ Lubricate all grease fitting locations. Make sure PTO shaft slip joint is lubricated.
- \_\_\_ Check to be sure gear lube runs out the small check plug on side of gearbox.
- \_\_\_ Check that all hardware is properly installed and secured.
- \_\_\_ Check that blades are sharp and secure and cutting edge is positioned to lead in a counterclockwise rotation.
- \_\_\_ Check that shields and guards are properly installed and in good condition. Replace if damaged.
- \_\_\_ Check cutting height, front-to-rear attitude, and top link adjustment.
- \_\_\_ Place tractor PTO and transmission in neutral before starting engine.
- \_\_\_ Inspect area to be cut and remove stones, branches, or other hard objects that might be thrown and cause injury or damage.



# OWNER SERVICE

The information in this section is written for operators who possess basic mechanical skills. If you need help, your dealer has trained service technicians available. For your protection, read and follow the safety information in this manual

## **WARNING**

■ **Keep all persons away from operator control area while performing adjustments, service, or maintenance.**

## **CAUTION**

■ **If you do not understand any part of this manual and need assistance, see your dealer.**

■ **Always wear relatively tight and belted clothing to avoid getting caught in moving parts. Wear sturdy, rough-soled work shoes and protective equipment for eyes, hair, hands, hearing, and head; and respirator or filter mask where appropriate.**

## **BLOCKING METHOD**

## **WARNING**

■ **Before performing any service or maintenance, disconnect driveline from tractor PTO.**

■ **Never go underneath equipment (lowered to the ground or raised) unless it is properly blocked and secured. Never place any part of the body underneath equipment or between moveable parts even when the engine has been turned off. Hydraulic system leak down, hydraulic system failures, mechanical failures, or movement of control levers can cause equipment to drop or rotate unexpectedly and cause severe injury or death. Follow Operator's Manual instructions for working underneath and blocking requirements or have work done by a qualified dealer.**

To minimize the potential hazards of working underneath the cutter, follow these procedures.

1. Jackstands with a load rating of 1000 lbs or more are the only approved blocking device for this cutter. Install a minimum of four jackstands (shown by Xs in Figure 11) under each corner of the cutter before working underneath unit.

Do not position jackstands under wheels, axles, or wheel supports. Components can rotate and cause cutter to fall.

2. Consider the overall stability of the blocked unit. Just placing jackstands underneath will not ensure your safety.

The working surface must be level and solid to support the weight on the jackstands. Make sure jackstands are stable, both top and bottom. Make sure cutter is approximately level.

3. With full cutter weight lowered onto jackstands, test blocking stability before working underneath.
4. If cutter is attached to tractor when blocking, set the brakes, remove key, and block cutter before working underneath.
5. Securely block rear tractor wheels, in front and behind. Tighten tractor lower 3-point arm anti-sway mechanism to prevent side-to-side movement.

## **LUBRICATION INFORMATION**

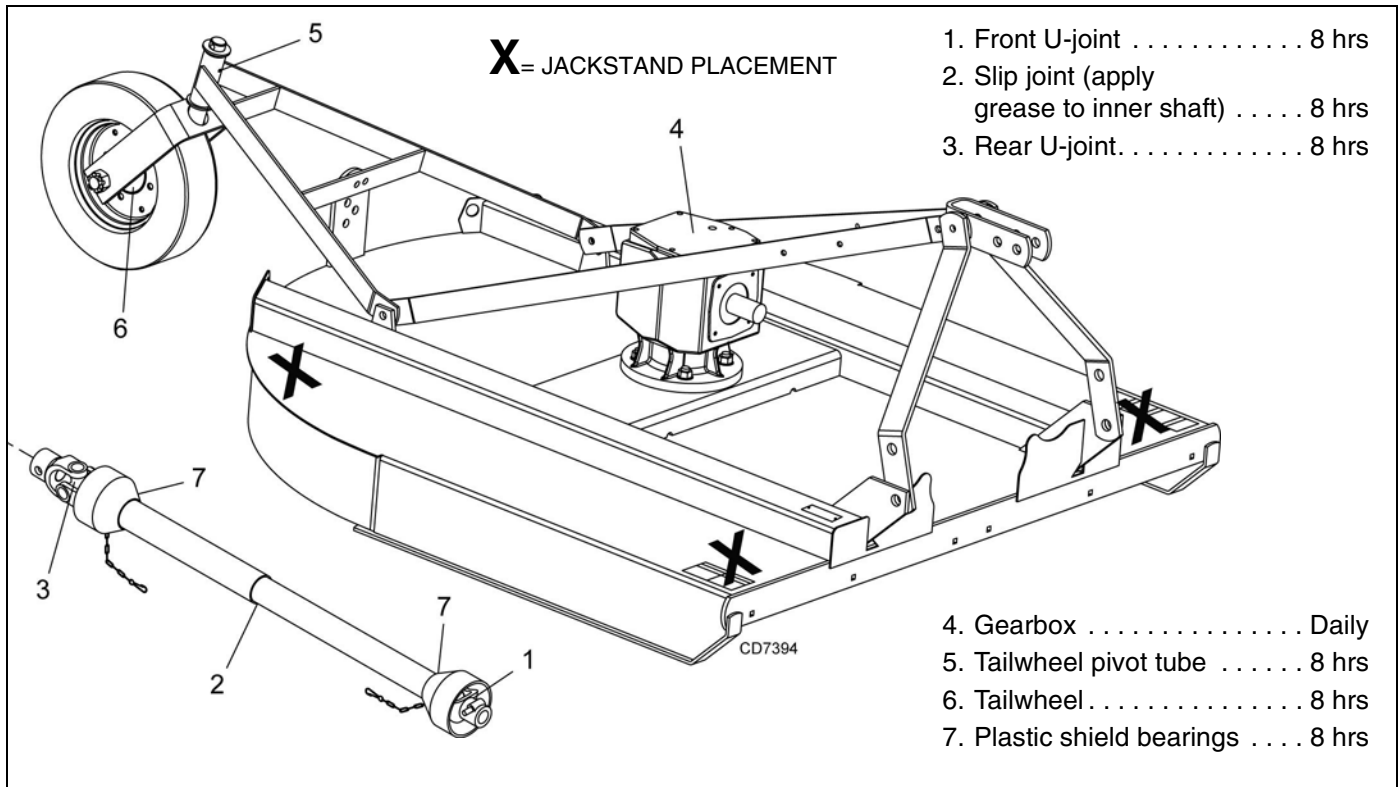
1. Do not let excess grease collect on or around parts, particularly when operating in sandy areas.
2. See Figure 11 for lubrication points and frequency of lubrication based on normal operating conditions. Severe or unusual conditions may require more frequent lubrication.
3. Use a lithium grease of #2 consistency with a MOLY (molybdenum disulfide) additive for all locations unless otherwise noted. Be sure to clean fittings thoroughly before attaching grease gun. One good pump of most guns is sufficient when the lubrication schedule is followed.

## **Gearbox Lubrication**

1. For gearbox, use a high quality gear oil with a viscosity index of 80W or 90W and an API service rating of GL-4 or -5 in gearboxes.
2. Fill gearbox until oil runs out the side plug on gearbox. Check gearbox daily for evidence of leakage, and contact your dealer if leakage occurs.

## **Driveline Lubrication**

1. Lubricate the driveline slip joint every eight operating hours. Failure to maintain proper lubrication could result in damage to U-joints, gearbox, and driveline.
2. Lower cutter to ground, disconnect driveline from tractor PTO shaft, and slide halves apart but do not disconnect from each other.
3. Apply a bead of grease completely around male half where it meets female half. Slide drive halves over each other several times to distribute grease.



**Figure 11.** Jackstand Placement and Lubrication Points

**BLADE SERVICING**

**Blade Removal**

***NOTICE***

■ If blade pin is seized in crossbar and extreme force will be needed to remove it, support crossbar from below to prevent gearbox damage.

3. Align crossbar (8) with blade access hole in the cutter frame. Remove blade pin nut (14) and lock washer (15). Carefully drive pin (12) out of crossbar.
4. Rotate crossbar and repeat for opposite blade.

**Blade Installation**

**⚠ CAUTION**

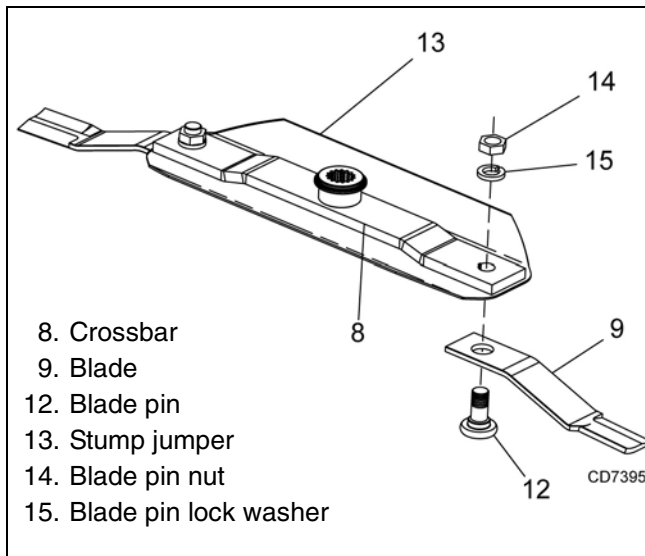
- Your dealer can supply genuine replacement blades. Substitute blades may not meet original equipment specifications and may be dangerous.
- Crossbar rotation is counterclockwise when looking down on cutter. Be sure to install blade cutting edge to lead in counterclockwise rotation.

***NOTICE***

■ Always replace or sharpen both blades at the same time.

Refer to Figure 12.

1. Inspect blade pin (12) for nicks or gouges, and if you find any replace the blade pin.
2. Insert blade pin through the blade (9). Blade should swivel on blade pin; if it doesn't, determine the cause and correct.



**Figure 12.** Blade Assembly

1. Disconnect driveline from tractor PTO.
2. Raise cutter and block securely (see Figure 11).

- Align crossbar (8) with blade access hole in cutter frame. Apply a liberal coating of Never Seez<sup>®</sup> or equivalent to blade pin and crossbar hole. Make sure blade offset is away from cutter. Push blade pin through crossbar.
- Insert lock washer (15) and nut (14) through blade access hole in the cutter frame. Install on blade pin (12) and tighten to 450 lbs-ft using a 1-11/16" socket.

## Blade Sharpening

### NOTICE

■ Closely inspect blades for cracks or nicks, replace damaged blades in sets.

■ When sharpening blades, grind the same amount on each blade to maintain balance. Replace blades in pairs. Unbalanced blades will cause excessive vibration, which can damage gearbox bearings. Vibration may also cause structural cracks to cutter.

- Sharpen both blades at the same time to maintain balance. Follow original sharpening pattern.
- Do not sharpen blade to a razor edge—leave at least a 1/16" blunt edge.
- Do not sharpen back side of blade.

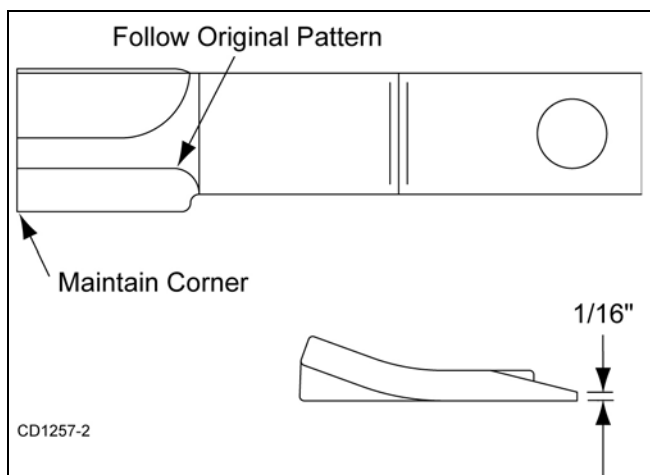


Figure 13. Blade Sharpening

## SLIP CLUTCH ADJUSTMENT

The slip clutch is designed to slip so that the gearbox and driveline are protected if the cutter strikes an obstruction.

A new slip clutch or one that has been in storage over the winter may seize. Before operating the cutter, make sure it will slip by performing the following operation:

- Turn off tractor engine and remove key.
- Loosen nuts on springs until the springs can rotate freely, yet remain secure on the bolts.
- Mark outer plates of slip-disc clutch as shown in Figure 14.
- Securely attach implement to the tractor and start the tractor.
- Engage PTO for several seconds then quickly disengage it.
- Turn tractor off and remove key.
- The friction lining plates should have "slipped". Check the marks placed on the outer plates of the slip-disc clutch in step 3 to make sure this is the case.
- If clutch does not slip, check assembly for oil, grease and debris. Clean if necessary.
- Reassemble clutch and tighten bolts no more than 1/8 of a turn at a time until desired setting of 1.26" is reached as shown in Figure 14.
- If excessive slippage continues, check lining plates for excessive wear. They are 1/8" thick when new and should be replaced after 1/32" of wear to ensure proper operation.

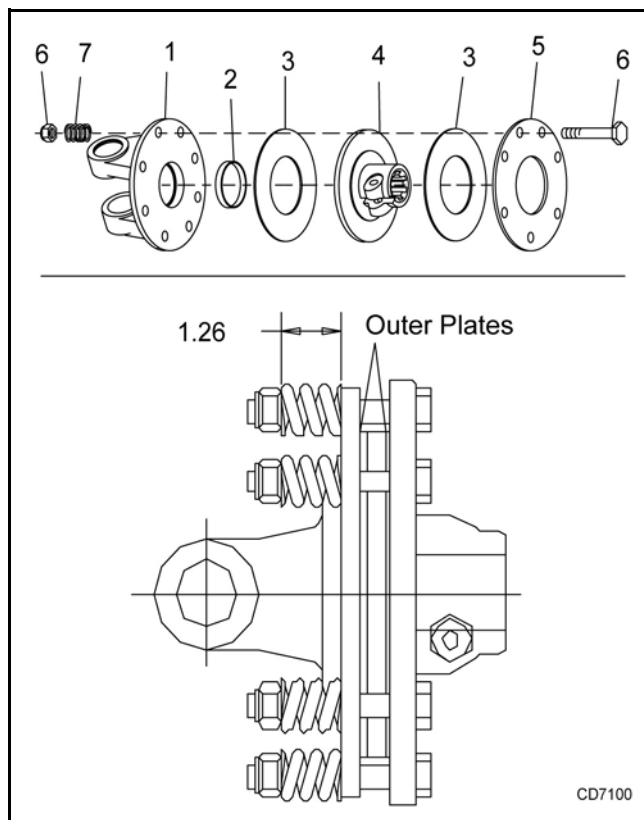


Figure 14. Slip Clutch Assembly

## DRIVELINE SHEAR BOLT REPLACEMENT

### **NOTICE**

■ Always use approved 1/2" NC x 3" grade 2 shear bolt as a replacement part. Using a hardened bolt or shear pin may result in damage to driveline or gearbox.

1. Remove driveline shield bell (1).
2. Remove damaged shear bolt (4).
3. Rotate driveline to align holes in yoke and shaft. Install shear bolt and secure with lock nut. Replace driveline shield bell.

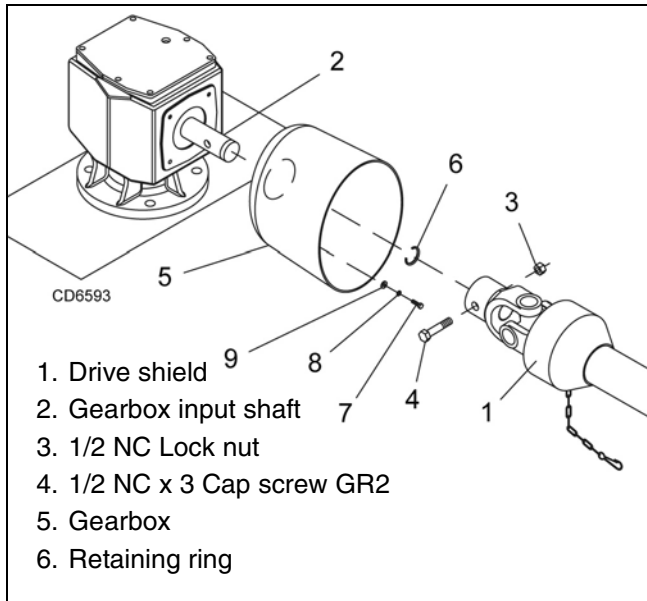


Figure 15. Shear Bolt Driveline Assembly

## SHIELDING REPAIR

### **⚠ DANGER**

■ Full chain, rubber, or steel band shielding, designed to reduce the possibility of thrown objects, must be installed when operating in populated areas or other areas where thrown objects could injure people or damage property. If this machine is not equipped with full chain, rubber, or steel band shielding, operation must be stopped when anyone comes within 300 feet.

## **Rear Band**

Inspect rear band each day of operation and replace if bent, cracked or broken.

## **Rubber Shielding**

Inspect rubber shielding each day of operation and replace if cracked or broken.

## **Optional Chain Shielding**

Inspect chain shielding each day of operation and replace any broken or missing chains as required.

## CLEANING

### **After Each Use**

- Remove large debris such as clumps of dirt, grass, crop residue, etc. from machine.
- Inspect machine and replace worn or damaged parts.
- Replace any safety decals that are missing or not readable.

### **Periodically or Before Extended Storage**

- Clean large debris such as clumps of dirt, grass, crop residue, etc. from machine.
- Remove the remainder using a low-pressure water spray.
  1. Be careful when spraying near scratched or torn safety decals or near edges of decals as water spray can peel decal off surface.
  2. Be careful when spraying near chipped or scratched paint as water spray can lift paint.
  3. If a pressure washer is used, follow the advice of the pressure washer manufacturer.
- Inspect machine and replace worn or damaged parts.
- Sand down scratches and the edges of areas of missing paint and coat with Woods spray paint of matching color (purchase from your Woods dealer).
- Replace any safety decals that are missing or not readable (supplied free by your Woods dealer). See Safety Decals section for location drawing.



# TROUBLESHOOTING

## MOWING CONDITIONS

PROBLEM	POSSIBLE CAUSE	SOLUTION
Grass cut lower in center of swath than at edge	Height of cutter lower at rear or front	Adjust cutter height and attitude so that cutter rear and front are within 1/2" of same height.
Streaking conditions in swath	Conditions too wet for mowing	Allow grass to dry before mowing.
	Blades unable to cut that part of grass pressed by path of tractor tires	Slow ground speed of tractor but keep engine running at full PTO RPM. Cutting lower will help.
	Dull blades	Sharpen or replace blades.
Material discharges from cutter unevenly; bunches of material along swath	Material too high and too much material	Reduce ground speed but maintain 540 RPM at tractor PTO or make two passes over material. Raise cutter for the first pass and lower to desired height for the second and cut at 90° to first pass. Raise rear of cutter high enough to permit material to discharge but not so high as to cause conditions listed above.
	Grass wet	Allow grass to dry before mowing. Slow ground speed of tractor but keep engine running at full PTO RPM. Cutting lower will help.
	Rear of cutter too low, trapping material under cutter	Adjust cutter height and attitude.
Cutter will not cut (Shear bolt drive only)	Shear bolt sheared	Install new shear bolt.
Cutter will not cut all the time (Slip clutch drive only)	Slip clutch slipping	Adjust slip clutch according to instructions in Slip Clutch Adjustment, page 20.

# DEALER SERVICE

The information in this section is written for dealer service personnel. The repair described here requires special skills and tools. If your shop is not properly equipped or your mechanics are not properly trained in this type of repair, you may be time and money ahead to replace complete assemblies.

## WARNING

■ **Before working underneath, disconnect drive-line, raise cutter, lock in transport position, and block cutter securely. Hydraulic system leak down and failure of mechanical or hydraulic system can cause equipment to drop.**

■ **Keep all persons away from operator control area while performing adjustments, service, or maintenance.**

## CAUTION

■ **Always wear relatively tight and belted clothing to avoid getting caught in moving parts. Wear sturdy, rough-soled work shoes and protective equipment for eyes, hair, hands, hearing, and head; and respirator or filter mask where appropriate.**

## GEARBOX MAINTENANCE

**NOTE:** Read this entire section before starting any repair. Many steps are dependent on each other.

1. Fill gearbox with SAE 80W or 90W gear lube until it runs out the side level plug.

**NOTE:** Repair to this gearbox is limited to replacing bearings, seals, and gaskets. Replacing gears, shafts, and a housing is not cost effective. Purchasing a complete gearbox is more economical.

2. Inspect gearbox for leakage and bad bearings. Leakage is a very serious problem and must be corrected immediately. Bearing failure is indicated by excessive noise and side-to-side or end-play in gear shafts.

## Seal Replacement

Recommended sealant for gearbox repair is Permatex® Aviation 3D Form-A-Gasket or equivalent.

Leakage can occur at the vertical or horizontal gaskets and shaft seals.

Leakage at the horizontal gasket or seal can be repaired without removing the gearbox from the cutter.

## Seal Installation

**NOTE:** Proper seal installation is important. An improperly installed seal will leak.

1. Clean area in housing where seal outer diameter (OD) seats. Apply a thin coat of Permatex.
2. Inspect area of shaft where seal seats. Remove any burrs or nicks with an emery cloth.
3. Lubricate gear shaft and seal lips.
4. Place seal squarely on housing, spring-loaded lip toward housing. Select a piece of pipe or tubing with an OD that will sit on the outside edge of the seal but will clear the housing. Tubing with an OD that is too small will bow seal cage and ruin seal.
5. Carefully press seal into housing, avoiding distortion to the metal seal cage.

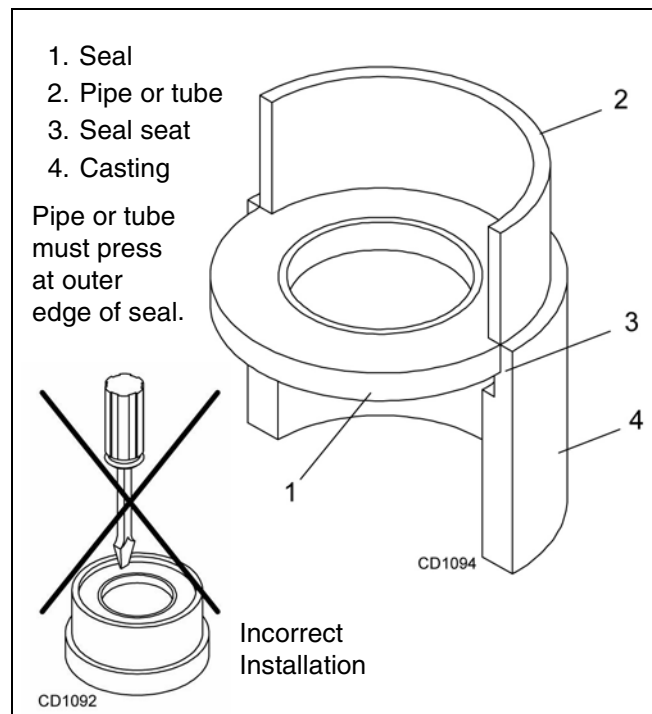


Figure 16. Seal Installation



## Vertical Shaft Repair (Flat Top) (Figure 17)

1. Disconnect and remove the rear driveline from the gearbox.
2. Remove vent plug (27) and siphon gear lube from housing through this opening.
3. Remove crossbar (see **Crossbar Removal, page 27**).
4. Remove vertical shaft seal (21). Replace with new seal (see **Seal Installation, page 23**).

Vertical seal should be recessed in housing. Horizontal seal should be pressed flush with outside of housing.

**NOTE:** Distortion to seal cage or damage to seal lip will cause seal to leak.

5. Fill gearbox with SAE 80W or 90W gear lube until it runs out the level plug.
6. Remove and replace any seal damaged in installation.

## Horizontal Leak Repair (Flat Top) (Figure 17)

1. Disconnect and remove the rear driveline from the gearbox.
2. Remove vent plug (27) and siphon gear lube from housing through this opening.
3. If the leak occurred at either end of horizontal shaft, remove oil cap (23) and/or oil seal (22). Replace with new one (refer to **Seal Installation, page 23**).
4. Fill gearbox with SAE 80W or 90W gear lube until it runs out the level plug.

## GEARBOX REPAIR (FLAT TOP) (Figure 17)

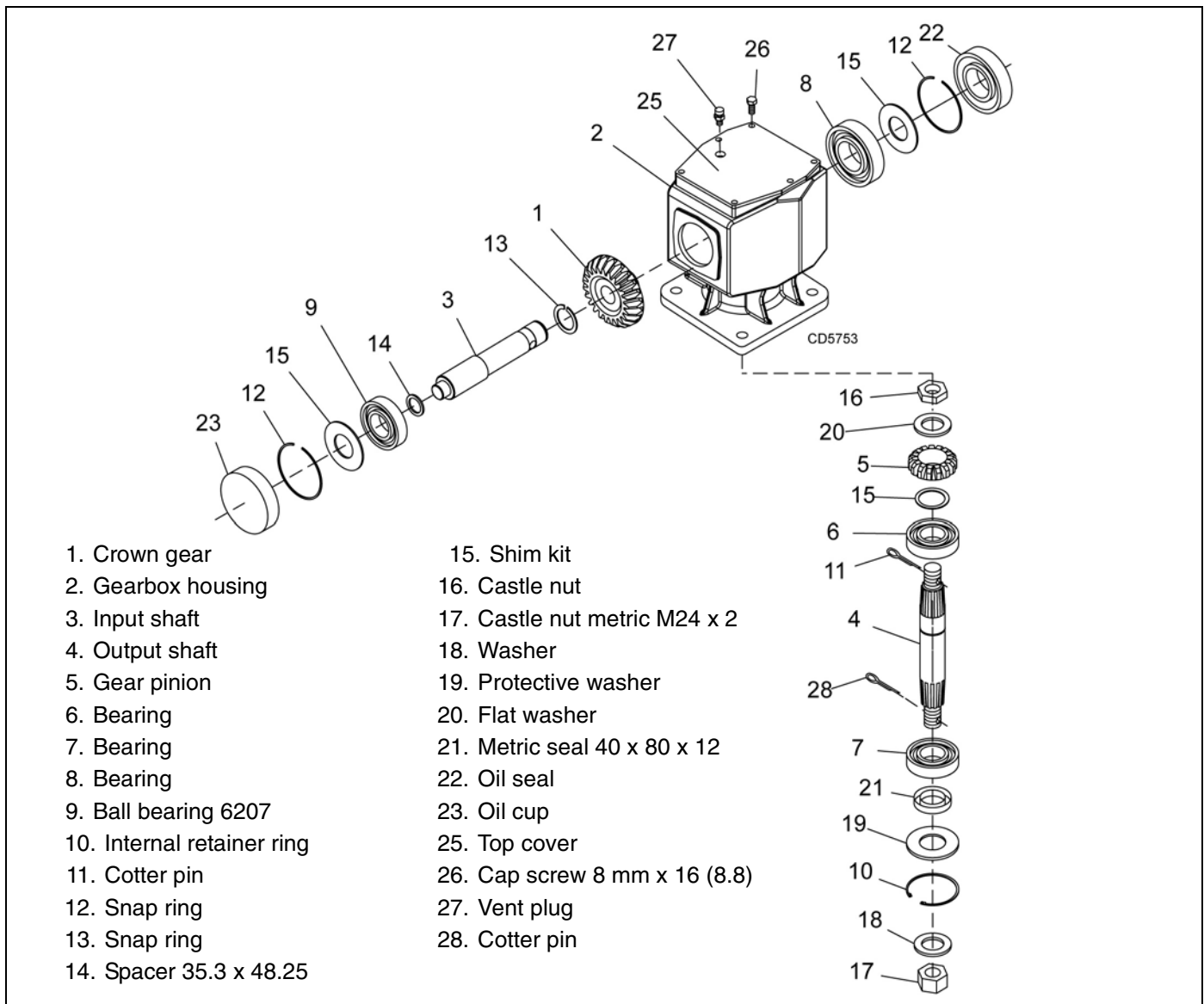
**NOTE:** Repair to this gearbox is limited to replacing bearings, seals, and gaskets. Replacing gears, shafts, and a housing is not cost effective. Purchasing a complete gearbox is more economical.

### Disassemble Gearbox

1. Remove 3/8" plug from side of gearbox and pour out gear oil.

2. Remove oil cap (23) (to be replaced).
3. Remove snap ring (12) and shim (15) from input shaft (3).
4. Support gearbox in hand press and push on input shaft (3) to remove bearing (9) and spacer (14).
5. Remove top cover (25) from housing. Remove gear (1) from inside housing.
6. Remove oil seal (22) from front of housing (to be replaced).
7. Remove snap ring (12) and shim (15) from front of housing (2).
8. Remove input bearing (8) by using a punch and hammer from outside of housing.
9. Support housing in vise in a horizontal position.
10. The castle nut (17), cotter pin (28), washer (18), and hub (24) are already removed with the stump jumper/crossbar. Remove the snap ring (10), washer (19), and seal (21).
11. Remove cotter pin (11), castle nut (16), and washer (20) from output shaft (4).
12. Remove output shaft (4) by using a punch and hammer and tap on top to drive down.
13. Remove gear (5) and shim (15) from inside housing.
14. Remove bearing (7) by using a punch and hammer from the top, outside the housing.
15. Support housing upside down (top cover surface) and remove bearing (6) by using a punch and hammer from the bottom side of the housing.
16. Inspect gears for broken teeth and wear. Some wear is normal and will show on loaded side. Forged gear surfaces are rough when new. Check that wear pattern is smooth.
17. Inspect vertical and horizontal shafts for grooves, nicks, or bumps in the areas where the seals seat. Resurface any damage with emery cloth.
18. Inspect housing and caps for cracks or other damage.





**Figure 17.** Gearbox Assembly (Flat Top Gearbox)

### Reassemble Gearbox

1. Clean housing, paying specific attention to areas where gaskets will be installed.
2. Wash housing and all components thoroughly. Select a clean area for gearbox assembly. Replace all seals, bearings, and gaskets. All parts must be clean and lightly oiled before reassembling.
3. Insert output bearings (6 & 7) in the housing, using a round tube of the correct diameter and a hand press.
4. Slide output shaft (4) through both bearings (6 & 7) until it rests against bearing (6).
5. Slide shim (15) over output shaft (4).
6. Press gear (5) onto output shaft (4) and secure with washer (20), castle nut (16), and cotter pin (11).
7. Apply grease to lower seal lips (21) and press seal (21) over output shaft (4), using a tube of the correct diameter. Be sure not to damage the seal lip.  
  
Press in housing so that seal is recessed. Insert protective washer (19) by hand. Install snap ring (10) and position it together with dual lip seal (21) by pressing it into position. Verify that snap ring is seated correctly.
8. Press bearing (8) into the housing, using a round tube of the correct diameter and a hand press. Secure with shim (15) and snap ring (12).

9. Secure snap ring (13) on input shaft (3) if not already secure.
10. Place gear (1) through top of housing and align gear (1) and gear (5) so that gear teeth are a match.
11. While holding gear (1) in place, slide input shaft (3) through gear (1) and bearing (8). Align splines on shaft (3) and gear (1).
12. Slide spacer (14) over input shaft (3) and press bearing onto input shaft (3), using a round tube of the correct diameter and a hand press.
13. Slide shim (15) over input shaft (3) and secure with snap ring (12).
14. Check input shaft end float by moving the input shaft (3) by hand. If end float is higher than 0.012", insert shim between input shaft (3) and rear bearing (8). Repeat until end float is less than 0.012". Check rotational torque by hand. The torque should be less than 2.2 lbs-inch.
15. Check that the gear backlash is between 0.006" and 0.016". You should not have to adjust the backlash.
16. Press in input oil seal (22), using tube of correct diameter. Be careful not to damage seal lip.
17. Press oil cap (23) on to cover the rear of housing, using a tube of the correct diameter.
18. Check gearbox housing for leaks by plugging all holes except one. Apply 4 psi compressed air and immerse the gearbox in water to verify that there are no leaks.
19. Remove gearbox from water and dry off with compressed air. Add SAE 80W or 90W EP oil until it runs out of side level hole. Tighten all plugs.

## Reinstall Gearbox

**NOTE:** Gearbox is heavy: do not attempt to move without mechanical assistance.

1. Set gearbox on cutter and fasten with bolts and nuts. Torque bolts to 175 lbs-ft
2. Attach crossbar (See **Crossbar Installation, page 28**).

## **GEARBOX REPAIR** **(ON CAST/CROWN TOP)** (Figure 18)

Refer to Figure 18.

**NOTE:** Repair to this gearbox is limited to replacing bearings, seals, and gaskets. Replacing gears, shafts, and a housing is not cost effective. Purchasing a complete gearbox is more economical.

**NOTE:** Replacing a complete flat top gearbox with a complete crown top gearbox will require replacing the cross bar assembly. See pages 36 and 37.

Gearbox is heavy: do not attempt to move without mechanical assistance.

## **Vertical Shaft Repair (Cast/Crown Top)**

1. Disconnect and remove the rear driveline from the gearbox. See Figure 18, page 27.
2. Remove vent plug (9) and siphon gear lube from housing through this opening.
3. Remove crossbar (see **Crossbar Removal, page 27**).
4. Remove output cap (17) and output seal (16) by removing four cap screws (13) and washers (12). Replace with new seal (see **Seal Installation, page 23**).

Vertical seal should be recessed in output cap.

**NOTE:** Distortion to seal cage or damage to seal lip will cause seal to leak.

5. Secure output cap (17) on to bottom of gearbox using four cap screws (13) and lock washers (12).  
**NOTE:** Make sure output gasket (10) and (11) are in place.
6. Fill gearbox with SAE 80W or 90W gear lube until it runs out the side level plug.
7. Remove and replace any seal damaged in installation.

## **Horizontal Leak Repair (Cast/Crown Top)**

1. Disconnect and remove the rear driveline from the gearbox.
2. Remove vent plug (9) and siphon gear lube from housing through this opening.
3. Remove input seal (4). Replace with new one (refer to **Seal Installation, page 23**).
4. Fill gearbox with SAE 80W or 90W gear lube until it runs out the side level plug.

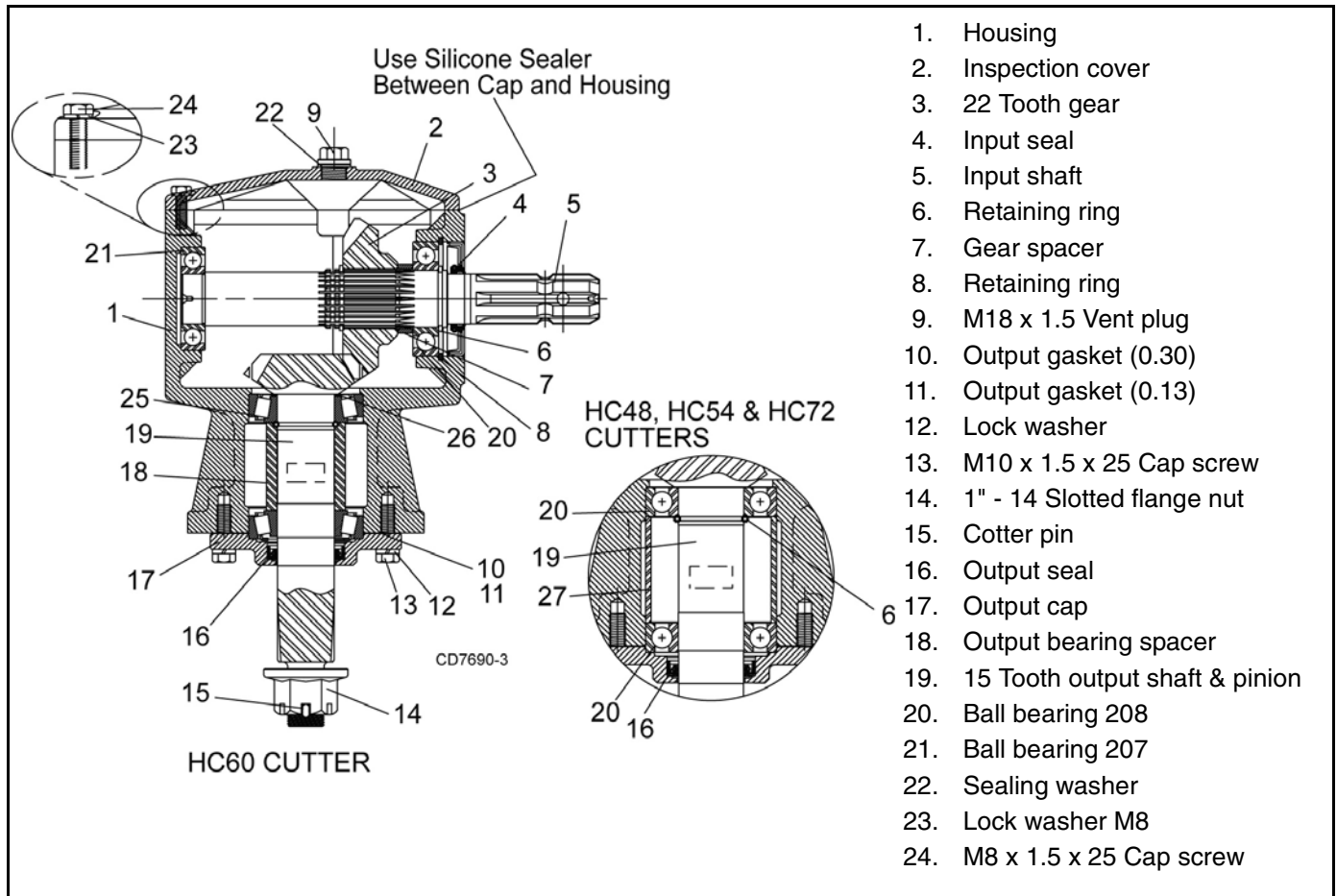


Figure 18. Gearbox Assembly (Cast/Crown Top Gearbox)

## CROSSBAR REMOVAL

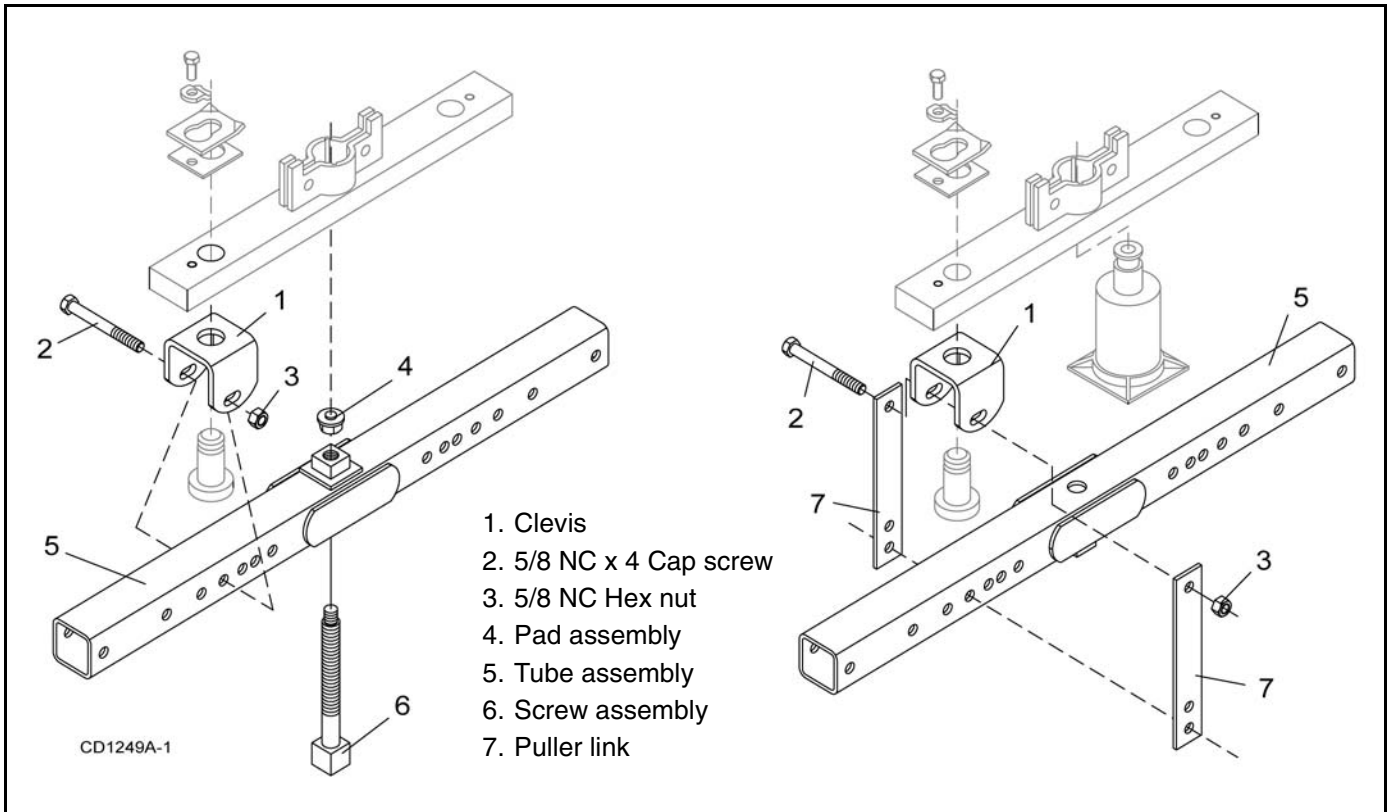
1. It is necessary to gain access to bottom side of cutter for crossbar removal. See **Blocking Method, page 18.**

**NOTE:** You will need to use either the puller screw (Item 6, ) or a small hydraulic jack to remove the crossbar.

2. To make crossbar removal easier, remove blades. See Blade Removal, page 19.
3. Remove cotter pin, castle nut, and washer from bottom of crossbar.
4. Attach a clevis (1) to each end of crossbar, using blade pins, spacers, keyhole plates, and blade pin clips. See Figure 19.

5. Position tube assembly (5) with threaded nut toward crossbar for puller screw removal or down for hydraulic jack removal.
6. For removal with puller screw, attach tube (5) to each clevis with bolts (2) and nuts (3). Place pad (4) in nut and thread puller screw (6) into nut from bottom. Tighten until pad is solid against gearbox shaft. For best results, strike head of puller screw with a hammer while tightening with a wrench.
7. For removal with a jack, attach tube to each clevis with puller links (7), bolts (2), and nuts (3). Place jack on tube with end of jack pressing against gearbox shaft. Slowly apply force with jack.

**NOTE:** Hydraulic jack will not operate if tipped more than 90-degrees. Use care to prevent bending crossbar during removal.



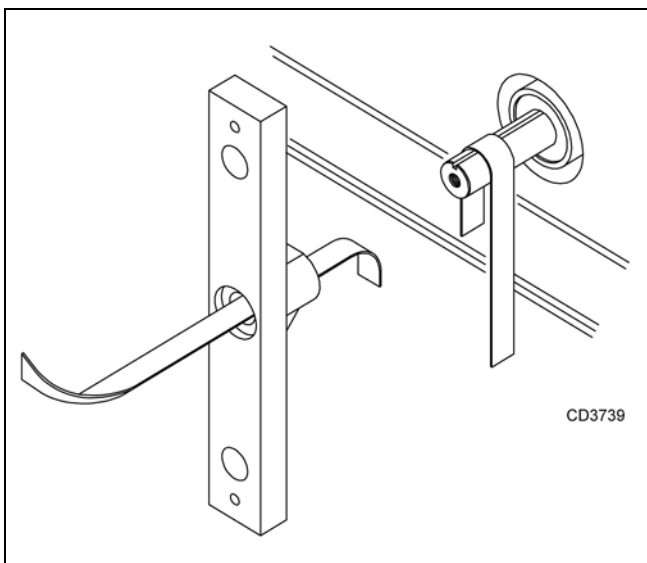
**Figure 19.** Crossbar Removal

## **CROSSBAR INSTALLATION**

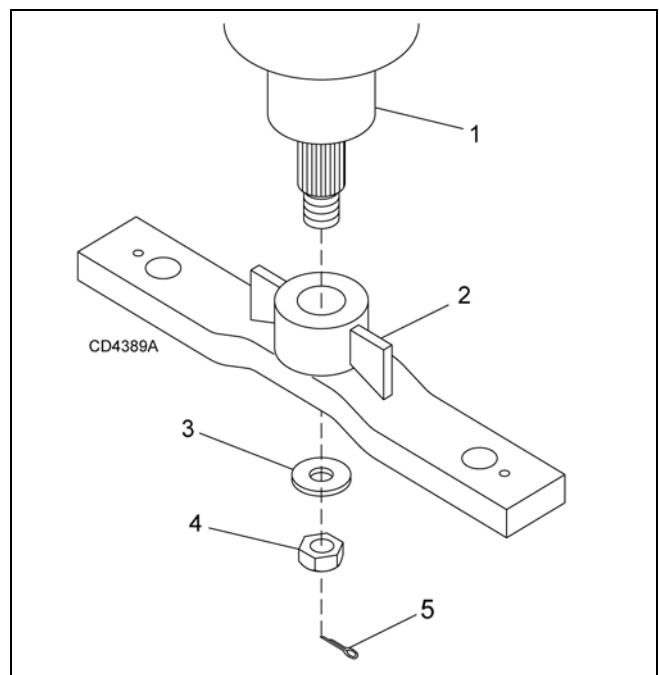
1. Using emery cloth (220 or finer), remove surface rust, Loctite® and foreign material from hub, splined gearbox, vertical shaft, and crossbar as shown in Figure 20.

2. Install crossbar (2) on splined shaft. Install washer, castle nut, and cotter pin. Torque nut to 200 lbs-ft.

3. Install the blades. See Blade Installation, page 19

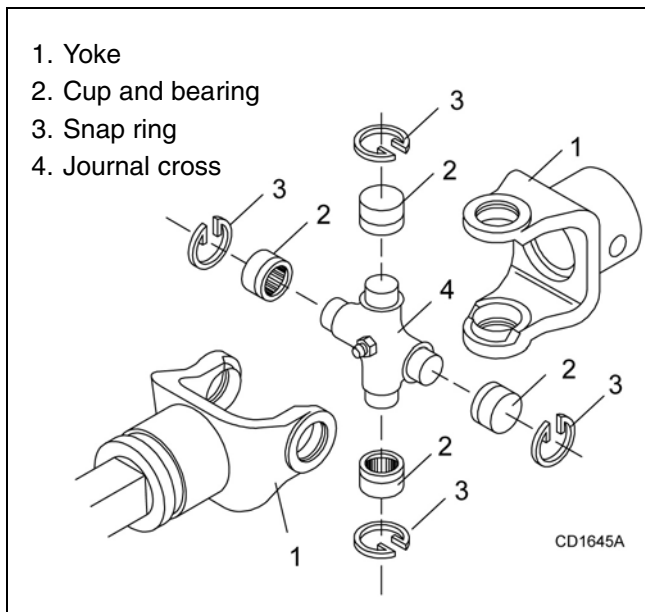


**Figure 20.**



**Figure 21**

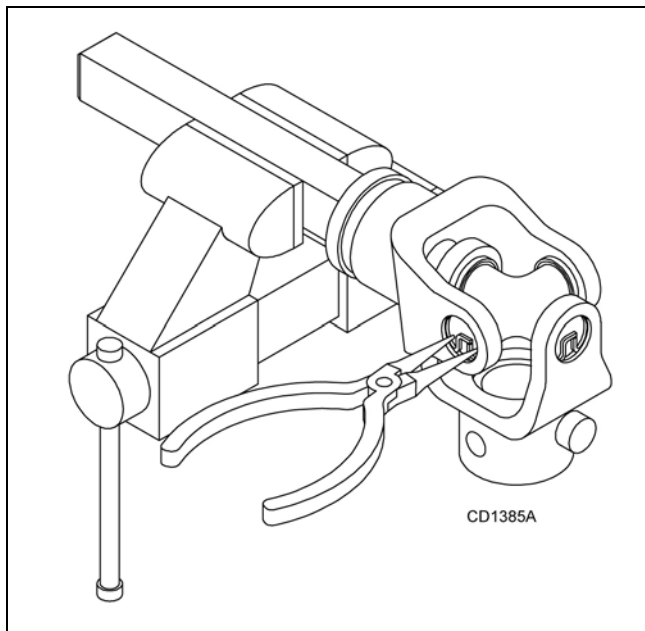
## UNIVERSAL JOINT REPAIR



**Figure 22.** Universal Joint Parts Breakdown

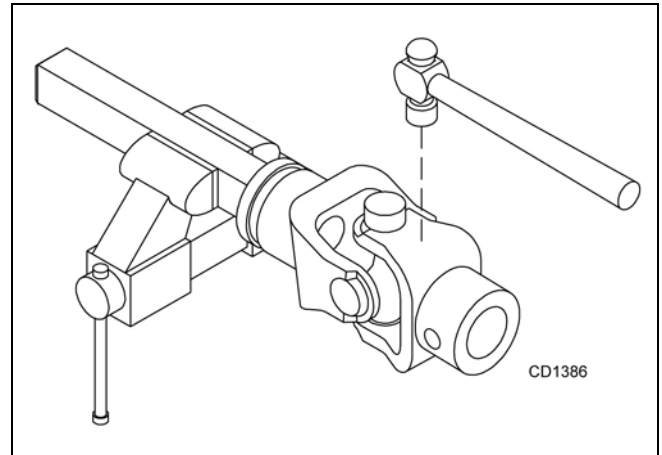
## U-Joint Disassembly

1. Remove external snap rings from yokes in four locations as shown in Figure 23.



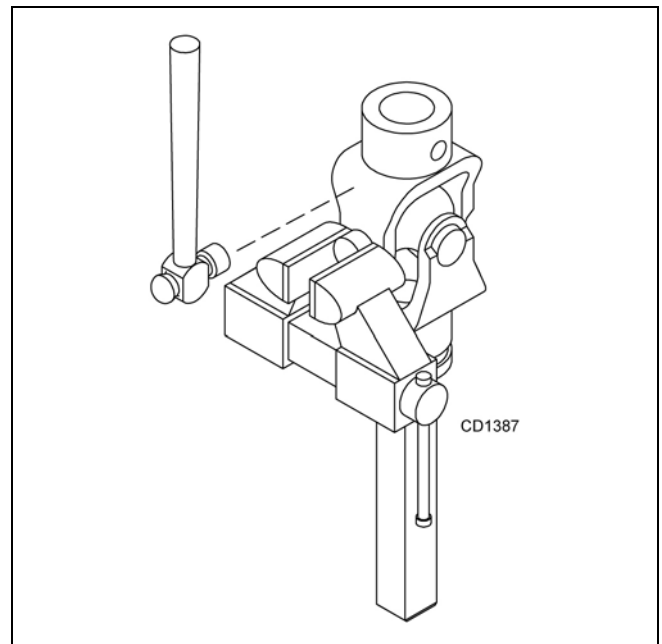
**Figure 23.** Remove Snap Ring

2. With snap rings removed, support drive in vise, hold yoke in hand and tap on yoke to drive cup up out of yoke. See Figure 24.



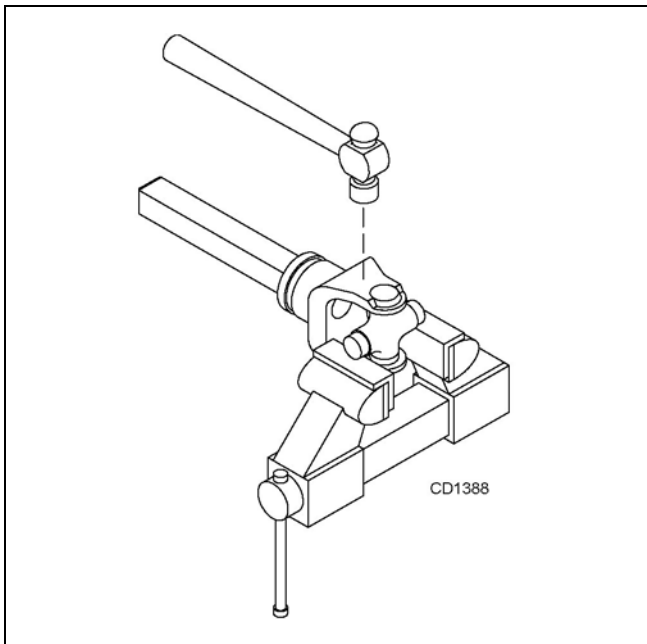
**Figure 24.** Remove Cups

3. Clamp cup in vise as shown in Figure 25 and tap on yoke to completely remove cup from yoke. Repeat Step 2 and Step 3 for opposite cup.



**Figure 25.** Remove Cups

4. Place universal cross in vise as shown in Figure 26 and tap on yoke to remove cup. Repeat Step 3 for final removal. Drive remaining cup out with a drift and hammer.

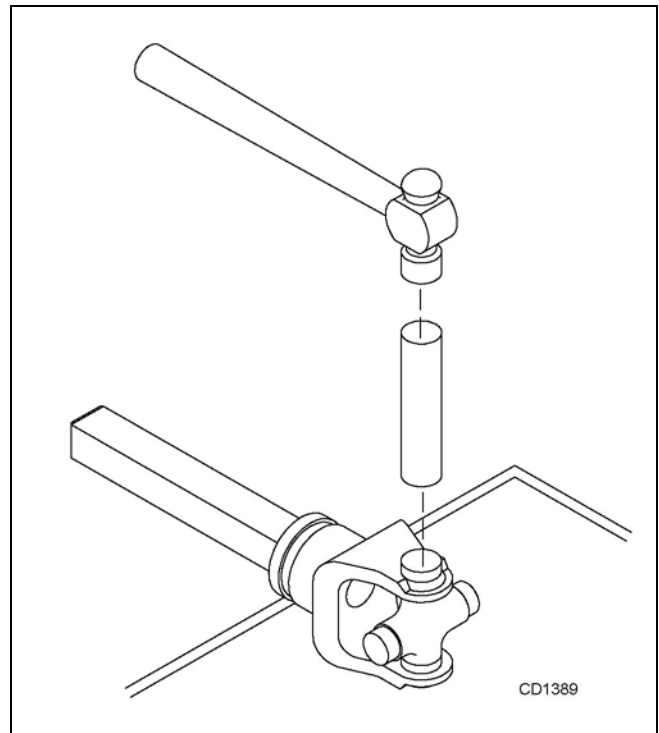


**Figure 26.** Remove Cups

3. Seat cups by placing a drift or socket (slightly smaller than the cup) on cup and rap with a hammer. See Figure 27. Install snap ring and repeat on opposite cup
4. Repeat Step 1 and Step 2 to install remaining cups in remaining yoke.
5. Move both yokes in all directions to check for free movement. If movement is restricted, rap on yokes sharply with a hammer to relieve any tension. Repeat until both yokes move in all directions without restriction.

### U-Joint Assembly

1. Place seals securely on bearing cups. Insert cup into yoke from outside and press in with hand pressure as far as possible. Insert journal cross into bearing cup with grease fitting away from shaft. Be careful not to disturb needle bearings. Insert another bearing cup directly across from first cup and press in as far as possible with hand pressure.
2. Trap cups in vise and apply pressure. Be sure journal cross is started into bearings and continue pressure with vise, squeezing in as far as possible. Tapping the yoke will help.



**Figure 27.** Install Cups



# ASSEMBLY

## DEALER SET-UP INSTRUCTIONS

Assembly of this cutter is the responsibility of the Woods dealer. It should be delivered to the owner completely assembled, lubricated, and adjusted for normal cutting conditions.

The cutter is shipped partially assembled. Assembly will be easier if aligned and loosely assembled before tightening hardware. Recommended torque values for hardware are located in the **Bolt Torque Chart, page 47.**

Complete **Dealer Check Lists, page 34** when you have completed the assembly.

### **⚠ DANGER**

- **Full chain, rubber, or steel band shielding must be installed when operating in populated areas or other areas where thrown objects could injure people or damage property.**
  - **If this machine is not equipped with full chain, rubber, or steel band shielding, operation must be stopped when anyone comes within 300 feet**

(92 m).

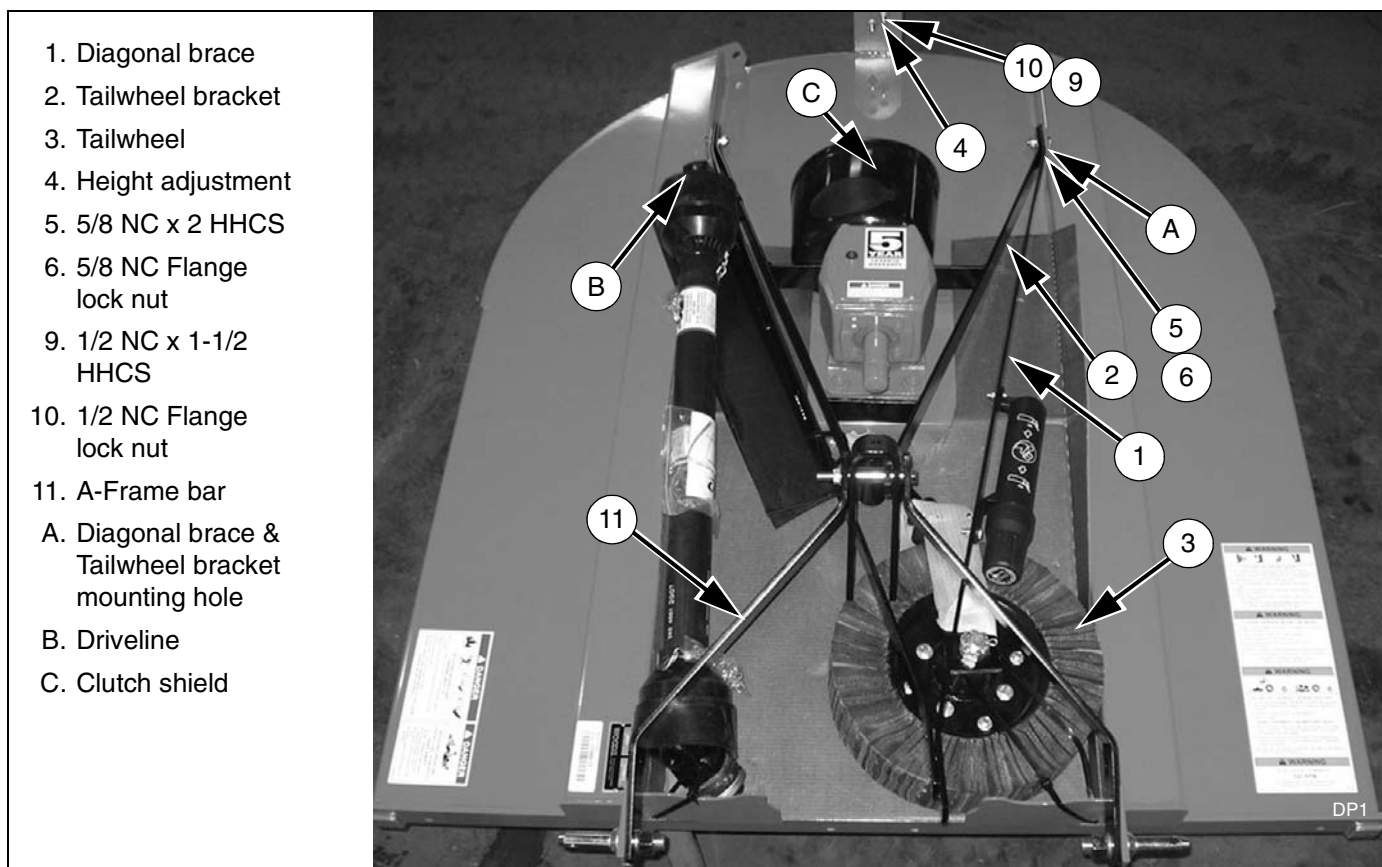
- **This shielding is designed to reduce the risk of thrown objects. The mower deck and protective devices cannot prevent all objects from escaping the blade enclosure in every mowing condition. It is possible for objects to ricochet and escape, traveling as much as 300 feet (92 m).**

### **⚠ WARNING**

- **Make sure spring-activated locking pin or collar slides freely and is seated firmly in tractor PTO spline groove.**

### **⚠ CAUTION**

- **Always wear relatively tight and belted clothing to avoid getting caught in moving parts. Wear sturdy, rough-soled work shoes and protective equipment for eyes, hair, hands, hearing, and head; and respirator or filter mask where appropriate.**



**Figure 28.** Shipping Configuration

## DISASSEMBLE SHIPPING UNIT

Remove all parts that are wired and strapped to cutter.

Remove cap screws (5) and flange lock nuts (6) that are securing tailwheel bracket (2) to the tailwheel bracket mounting holes (A).

## ASSEMBLE CUTTER

1. Attach tailwheel bracket (2) to cutter on the inside of tailwheel pivot holes (A) using cap screw (5) and flange lock nut (6) previously removed. Tighten hardware finger tight.

**NOTE:** Make sure grease fitting on tube is on top when installing tailwheel.

2. Select desired height adjustment holes (4), and secure tailwheel bracket with cap screws (9) and flange lock nuts (10). Cutting height adjustment will be necessary when cutter is fully assembled. See page 16.
3. Loosen hitch pins, rotate A-frame bars (11) up and align diagonal brace bars (1) with tailwheel pivot holes (A) and the inside of tailwheel bracket (2). Secure using cap screw (5) and flange lock nut (6) previously installed.
4. Disassemble clevis and A-Frame bars and attach diagonal braces to the outside of A-Frame bars. Secure all bars, clevis and sleeve with previously used hardware.
5. Tighten all hardware on cutter.
6. Raise rear of cutter and insert tailwheel assembly (3) into tailwheel bracket (2). Secure with washer (8) and spiral pin (7).

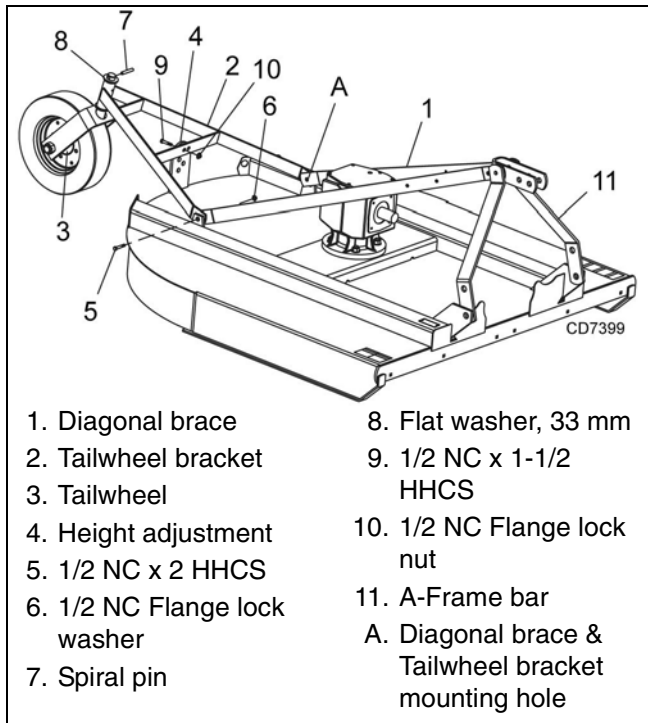


Figure 29. Tailwheel Installation

## INSTALL DRIVELINE

Select either the standard shear bolt or optional slip clutch driveline.

### Shear Bolt Driveline

## **NOTICE**

■ A grade 2 bolt must be used for the shear bolt to provide gearbox protection.

1. Position clutch shield (5) against gearbox. Secure using cap screw (7), lock washers (8), and flat washers (9). Torque hardware to 12 lbs-ft.
2. To prevent seal damage, carefully push driveline onto gearbox input shaft until it contacts the gearbox housing.
3. Place retaining ring (6) in slot on input shaft and snap into place.
4. Align the holes in the driveline yoke and gearbox input shaft. Install and tighten shear bolt (4) and nut (3).
5. Lubricate rear driveline half and install front driveline half.
6. Attach tether chain (if equipped) to clutch shield (5).

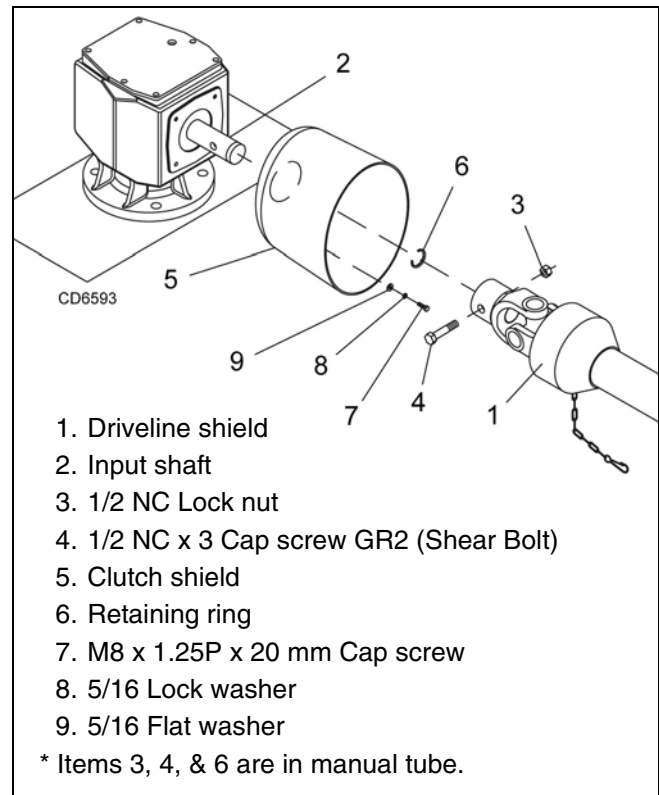


Figure 30. Shear Bolt Driveline Assembly



## Driveline Slip Clutch

### NOTICE

■ A grade 8 bolt must be used to attach clutch driveline to gearbox.

A new slip clutch, or one that has been in storage over the winter, may seize.

1. Before operating slip clutch, make sure it will slip. Refer to **Slip Clutch Adjustment, page 20**.
2. Position clutch shield (3) against gearbox. Secure using cap screw (4), lock washers (5), and flat washers (6). Torque hardware to 12 lbs-ft.
3. Slide driveline slip clutch onto gearbox input shaft and secure with bolt (1) and nut (2).
4. Lubricate rear driveline half and install front driveline half.
5. Attach tether chain (if equipped) to clutch shield (5).

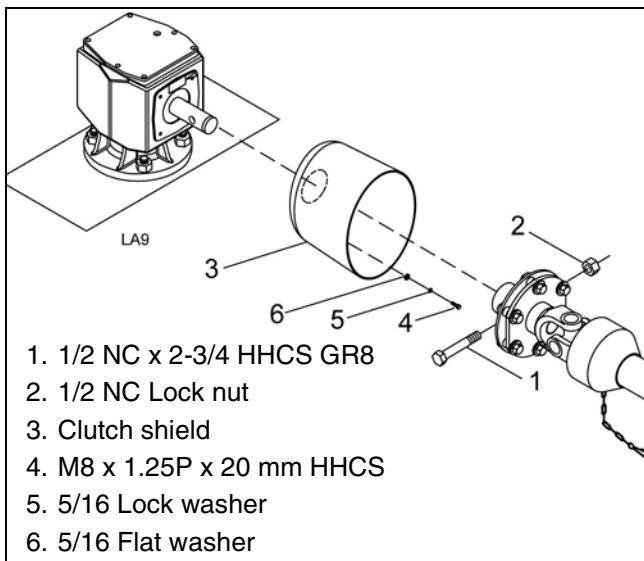


Figure 31. Slip Clutch Driveline Assembly

## FILL GEARBOX

### NOTICE

■ Gearbox is not filled at the factory. Prior to delivery to customer, make sure gearbox is filled only half-full with 80W or 90W API GL-4 or GL-5 gear lube. Use side plug to remove any excess oil.

1. Remove solid plug on top of gearbox and discard. Remove plug on side of gearbox.
2. Make sure vent plug hole is top of gearbox clear.
3. Fill gearbox until oil runs out the side hole on gearbox and install side plug. Use a high quality gear oil with a viscosity index of 80W or 90W and an API service rating of GL-4 or GL-5.
4. Install vent plug on top of gearbox. Use pipe sealant or thread tape on threads.

## INSTALL SAFETY SHIELDING

### Optional Chain Shielding

### ⚠ DANGER

■ Full chain, rubber, or steel band shielding must be installed when operating in populated areas or other areas where thrown objects could injure people or damage property.

- If this machine is not equipped with full chain, rubber, or steel band shielding, operation must be stopped when anyone comes within 300 feet (92 m).
- This shielding is designed to reduce the risk of thrown objects. The mower deck and protective devices cannot prevent all objects from escaping the blade enclosure in every mowing condition. It is possible for objects to ricochet and escape, traveling as much as 300 feet (92 m).

The optional chain shielding assemblies are ready for installation when you receive them. You must remove rear steel band before installing rear chain shielding.

1. Refer to **Front & Rear Chain Shielding, page 45**, and attach as shown by inserting the bolts from inside the cutter frame out through the shielding.
2. Install hardware as shown in the parts drawing.

**NOTE:** Rear band and front rubber deflector can be discarded if using chain shielding.

### Rubber Deflector

Attach rubber deflector (1) and link (2) to front of cutter using carriage bolts (3) and flange lock nuts (4).

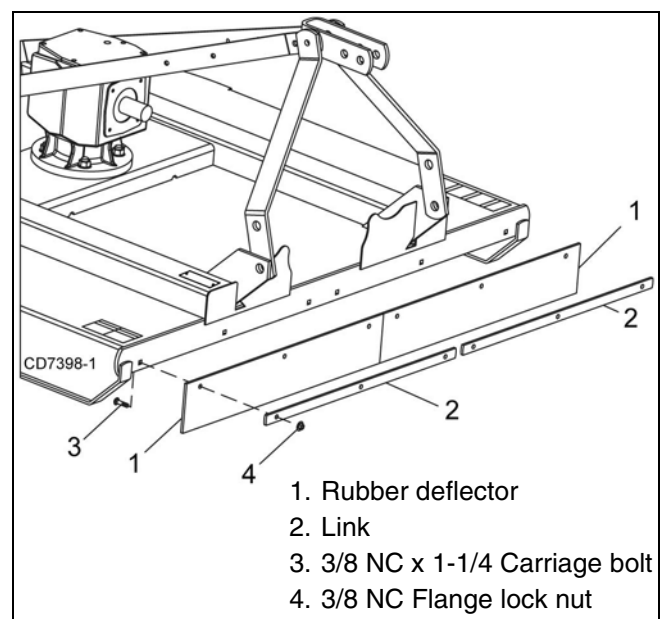


Figure 32. Rubber Deflector Installation

# DEALER CHECK LISTS

## PRE-DELIVERY CHECK LIST

(DEALER'S RESPONSIBILITY)

### **NOTICE**

■ **Gearbox was not filled at the factory. It must be serviced before operating cutter. (See Fill Gearbox, page 33). Failure to service will result in damage to gearbox.**

Inspect cutter thoroughly after assembly to make sure it is set up properly before delivering it to the customer. The following check list is a reminder of points to inspect. Check off each item as it is found satisfactory, corrections are made, or services are performed.

- \_\_\_ Check all bolts to be sure they are properly torqued.
- \_\_\_ Check that all cotter pins are properly installed and secured.
- \_\_\_ Check that PTO shaft is properly installed.
- \_\_\_ Check that gearbox is properly serviced and seals are not leaking.
- \_\_\_ Check and grease all lubrication points as identified in, **Lubrication Information, page 18 & 19.**
- \_\_\_ Check that blades have been properly installed.

## DELIVERY CHECK LIST

(DEALER'S RESPONSIBILITY)

- \_\_\_ Show customer how to make adjustments. Describe the options available for this cutter and explain their purpose.
- \_\_\_ Explain importance of lubrication to customer and point out lubrication points on cutter.
- \_\_\_ Present Operator's Manual and request that customer and all operators read it before operating equipment. Point out the manual safety rules, explain their meanings and emphasize the increased safety hazards that exist when safety rules are not followed.
- \_\_\_ Point out all guards and shielding. Explain their importance and the safety hazards that exist when not kept in place and in good condition.
- \_\_\_ For mounted units, add wheel weights, ballast in front tires, and/or front tractor weight to enhance front end stability. A minimum 20% of tractor and equipment gross weight must be on front tractor wheels. When adding weight to attain 20% of tractor and equipment weight on front tractor wheels, you must not exceed the ROPS weight certification. Weigh the tractor and equipment. Do not estimate!
- \_\_\_ Explain to customer that when equipment is transported on a road or highway, safety devices should be used to give adequate warning to operators of other vehicles.



### Heritage™

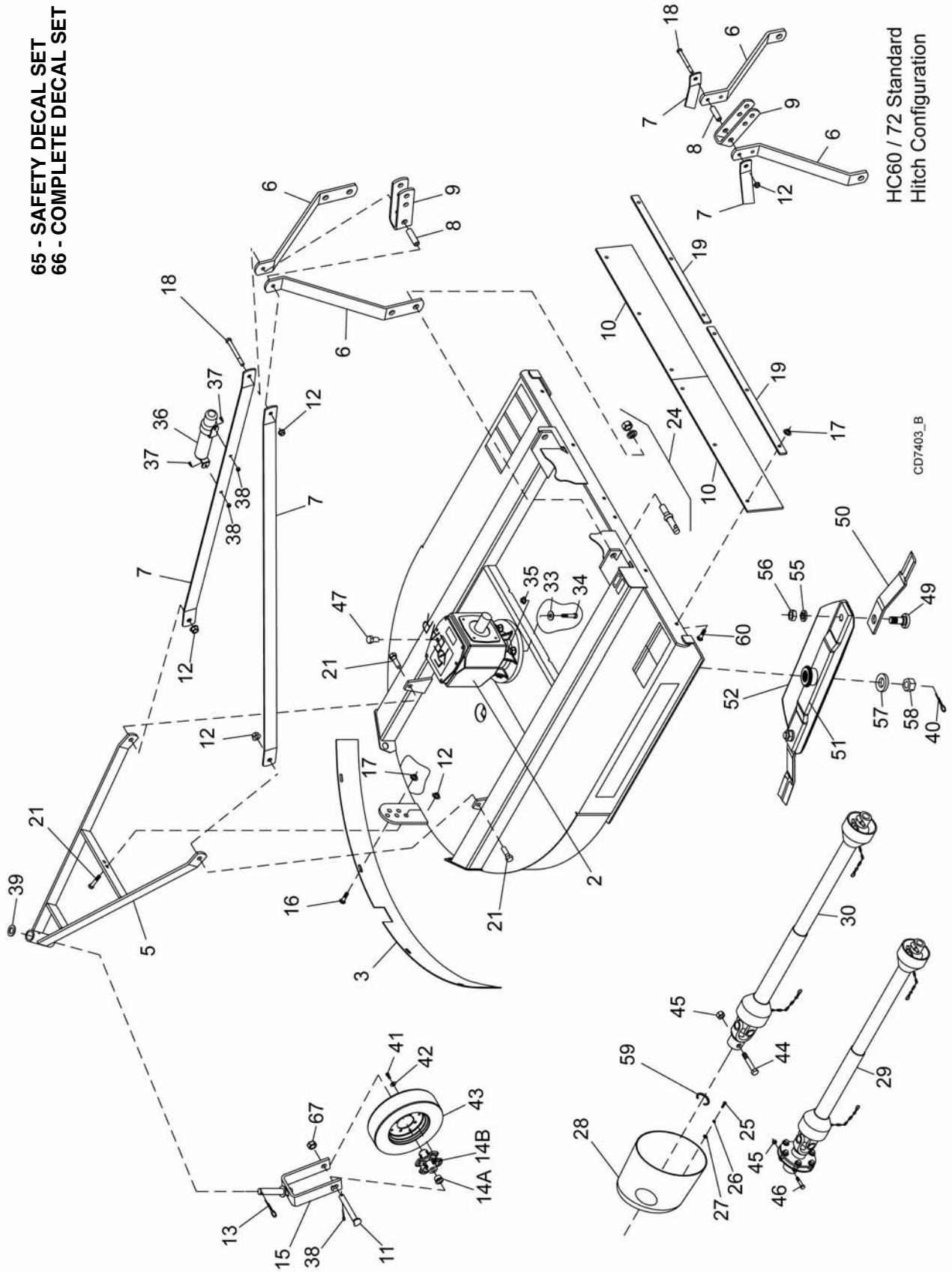
#### Rotary Cutters: HC48, HC54, HC60, HC72

HC48, HC54, HC60, HC72 ASSEMBLY .....	36 - 37
GEARBOX ASSEMBLY (FLAT TOP) .....	38
GEARBOX ASSEMBLY (CAST/CROWN TOP)(HC72 ONLY) .....	39
DRIVELINES:	
HC48 STANDARD DRIVELINE .....	40
HC54, HC60, HC72 STANDARD DRIVELINE .....	41
HC48, HC54, HC60 SLIP CLUTCH DRIVELINE (OPTIONAL) .....	42
HC72 SLIP CLUTCH DRIVELINE (OPTIONAL) .....	43
FRONT RUBBER SHIELDING (STANDARD).....	44
FRONT & REAR CHAIN SHIELDING (OPTIONAL) .....	45
QUICK HITCH HARDWARE (OPTIONAL) .....	46

# HC48, HC54, HC60, HC72 ASSEMBLY

65 - SAFETY DECAL SET  
66 - COMPLETE DECAL SET

HC60 / 72 Standard  
Hitch Configuration



CD7403\_B

36 Parts

(Rev. 4/20/2011)  
MAN0670 (11/16/2007)

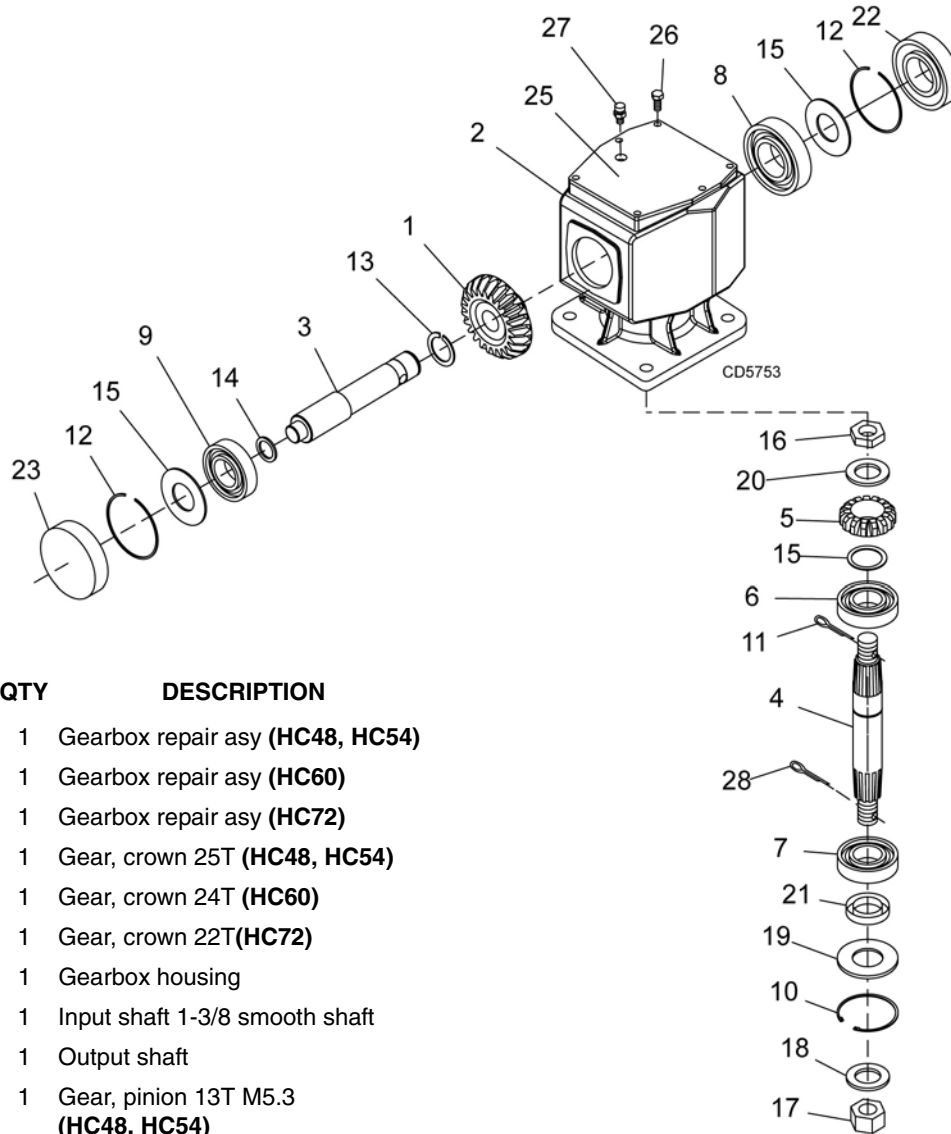
## HC48, HC54, HC60, HC72 ASSEMBLY PARTS LIST

REF	PART	QTY	DESCRIPTION	REF	PART	QTY	DESCRIPTION
2	58800	1	Gearbox <b>HC48, HC54</b> (see page 38)	30	1024217	1	Complete shear pin drive asy - <b>HC72</b> (see page 41)
2	58801	1	Gearbox <b>HC60</b> (see page 38)	32	33657	1	Sleeve, 1/2 x 3/4 x 2-13/16 (Quick Hitch) not shown
2	1026536	1	Gearbox <b>HC72</b> (see page 38) -or-	33	57817	4	5/8 Flat washer, hardened
2	1011794	1	Gearbox <b>HC72</b> (see page 39)	34	902 *	4	5/8 NC x 2 HHCS GR5
3	1017721	1	Rear band - <b>HC48</b>	35	19025 *	4	5/8 NC Flange lock nut
3	1017724	1	Rear band - <b>HC54</b>	36	1026530	1	Manual tube
3	1024213	1	Rear band - <b>HC60</b>	37	14562 *	2	5/16 NC x 1 HHCS GR5
3	1024177	1	Rear band - <b>HC72</b>	38	14139 *	2	5/16 NC Flange lock nut
5	1024215	1	Tailwheel assembly <b>HC48, HC54</b>	39	----- *	1	Washer, 33 mm x 56 mm x 4 mm
5	1024193	1	Tailwheel assembly <b>HC60, HC72</b>	40	----- *	2	Cotter pin
6	1007268	2	A-Frame bar <b>HC48, HC54</b>	41	300300	4	1/2 NC x 1 HHCS GR5
6	1024188	2	A-Frame bar <b>HC60, HC72</b>	42	----- *	4	1/2 Flat washer
7	1017718	2	Diagonal brace <b>HC48</b>	43	4676	1	4 x 8 Rim & laminated tire
7	1018042	2	Diagonal brace <b>HC54</b>	44	15349	1	1/2 NC x 3 Shear bolt GR2
7	1024212	2	Diagonal brace <b>HC60</b>	45	765 *	2	1/2 NC Lock nut
7	1024187	2	Diagonal brace <b>HC72</b>	46	15534 *	1	1/2 NC x 2-3/4 HHCS GR8 (Clutch)
8	64814	1	Spacer 1/2 x 2-3/4	47	57076	1	Vent plug, (See Gearbox, page 38)
9	15321	1	Link, bent .38 x 2.5 x 9.13	49	1026538	2	Blade pin, .75 x 1.5 x .38 <b>HC48, HC54</b> (includes items 55 & 56)
10	-----	2	Rubber shield (see page 44)	49	1015831	2	Blade pin, 1.5 x .5 <b>HC60, HC72</b> (includes items 55 & 56)
11	1030523	1	M24 x 2 Axle bolt	50	30310KT	1	Blade 3/8 x 3 x 16CCW <b>HC48, HC54</b>
12	11900	4	1/2 NC Flange lock nut	50	1016598KT	1	Blade 1/2 x 3 x 23.25 CCW <b>HC60</b>
13	40775	1	Spirol pin 10 mm x 65 mm	50	1016599KT	1	Blade 1/2 x 3 x 29.25 CCW <b>HC72</b>
14A	1030524	2	Bushing, flanged .984 x 1.378 x .98	51	1017715	1	Crossbar asy <b>HC48 (Flat Top Box)</b>
14B	1030522	1	Hub 4 bolt 4 x 8	51	1018039	1	Crossbar asy <b>HC54 (Flat Top Box)</b>
15	1028815	1	Tailwheel clevis	51	1024202	1	Crossbar asy <b>HC60, HC72 (Flat Top Box)</b>
16	6697 *	6	3/8 NC x 1 Carriage bolt GR5	51	1032592	1	Crossbar asy <b>HC48 (Crown Top Box)</b>
17	14350 *	14	3/8 NC Flange lock nut	51	1032594	1	Crossbar asy <b>HC54 (Crown Top Box)</b>
18	23479 *	1	1/2 NC x 5 HHCS GR5	51	1032596	1	Crossbar asy <b>HC60, HC72 (Crown Top Box)</b>
19	-----	2	Link, rubber shield (see page 44)	52	1017716	1	Stump jumper pan <b>HC48</b>
21	3379 *	3	1/2 NC x 1-1/2 HHCS GR5	52	1018040	1	Stump jumper pan <b>HC54</b>
22	10380 *	1	1/2 NC x 4 HHCS GR5 (Quick Hitch) not shown	52	1024199	1	Stump jumper pan <b>HC60, HC72</b>
24	33661	2	Cat 1 Mounting pin (with nut & lock washer)	55	15668	2	Lock washer, 1.15 x 1.85 x .281
25	24801	4	M8 x 1.25P x 20 mm HHCS	56	15667	2	Jam nut, 1-1/8 NF
26	35155 *	4	5/16 Flat washer	57	20893	1	Washer, 25 x 44 x 4 mm
27	2472 *	4	5/16 Lock washer	58	20892	1	Castle nut (M24 x 2)
28	1002048	1	Clutch shield, 100 x 143 mm BC	59	15345	1	Retaining ring, .05 x 1.38
29	1020900	1	Complete slip clutch drive asy - <b>HC48, HC54, HC60</b> (see page 42)	60	20973 *	8	3/8 NC x 1-1/4 Carriage bolt
29	1024218	1	Complete slip clutch drive asy - <b>HC72</b> (See page 43)	65	15358	1	Safety decal set
30	1009509	1	Complete shear bolt drive asy - <b>HC48</b> (See page 40) -or-	66	1026534	1	Complete decal set
30	1009510	1	Complete shear bolt drive asy - <b>HC54, HC60</b> (see page 41) -or-	67	1032105	1	Nut Slotted M24x2.0P

HHCS Hex Head Cap Screw

\* Standard hardware, obtain locally

## GEARBOX ASSEMBLY (FLAT TOP)



REF	PART	QTY	DESCRIPTION
A	58800	1	Gearbox repair asy (HC48, HC54)
A	58801	1	Gearbox repair asy (HC60)
A	1026536	1	Gearbox repair asy (HC72)
1	57458	1	Gear, crown 25T (HC48, HC54)
1	57459	1	Gear, crown 24T (HC60)
1	1026535	1	Gear, crown 22T(HC72)
2	NSS	1	Gearbox housing
3	57464	1	Input shaft 1-3/8 smooth shaft
4	57489	1	Output shaft
5	57491	1	Gear, pinion 13T M5.3 (HC48, HC54)
5	57497	1	Gear, pinion 14T M5.3 (HC60)
5	1026537	1	Gear, pinion 15T M5.7(HC72)
6	57476	1	Bearing cup & cone
7	57478	1	Bearing cup & cone
8	57462	1	Bearing cup & cone
9	20890	1	Bearing-Ball
10	20897	1	Ring retainer 81mm internal
11	----- *	1	Cotter pin
12	57466	2	Snap ring
13	20895	1	Snap ring
14	57373	1	Spacer 35.3 x 48 x 2.5
15	57328	2	Gearbox shim kit
16	57468	1	Castle nut
17	20892	1	Castle nut metric M24 x 2

REF	PART	QTY	DESCRIPTION
18	20893	1	Washer, 25 x 44 x 4 mm
19	20888	1	Protective washer
20	57473	1	Flat washer 21 x 37 x 3
21	20900	1	Seal, metric 40 x 80 x 12
22	57463	1	Oil seal 35 x 72 x 10
23	57374	1	Oil cap
25	57375	1	Top cover
26	----- *	6	M8 x 16 Hex head cap screw CL8.8
27	57076	1	Vent plug 1/2 NPT
28	----- *	1	Cotter pin

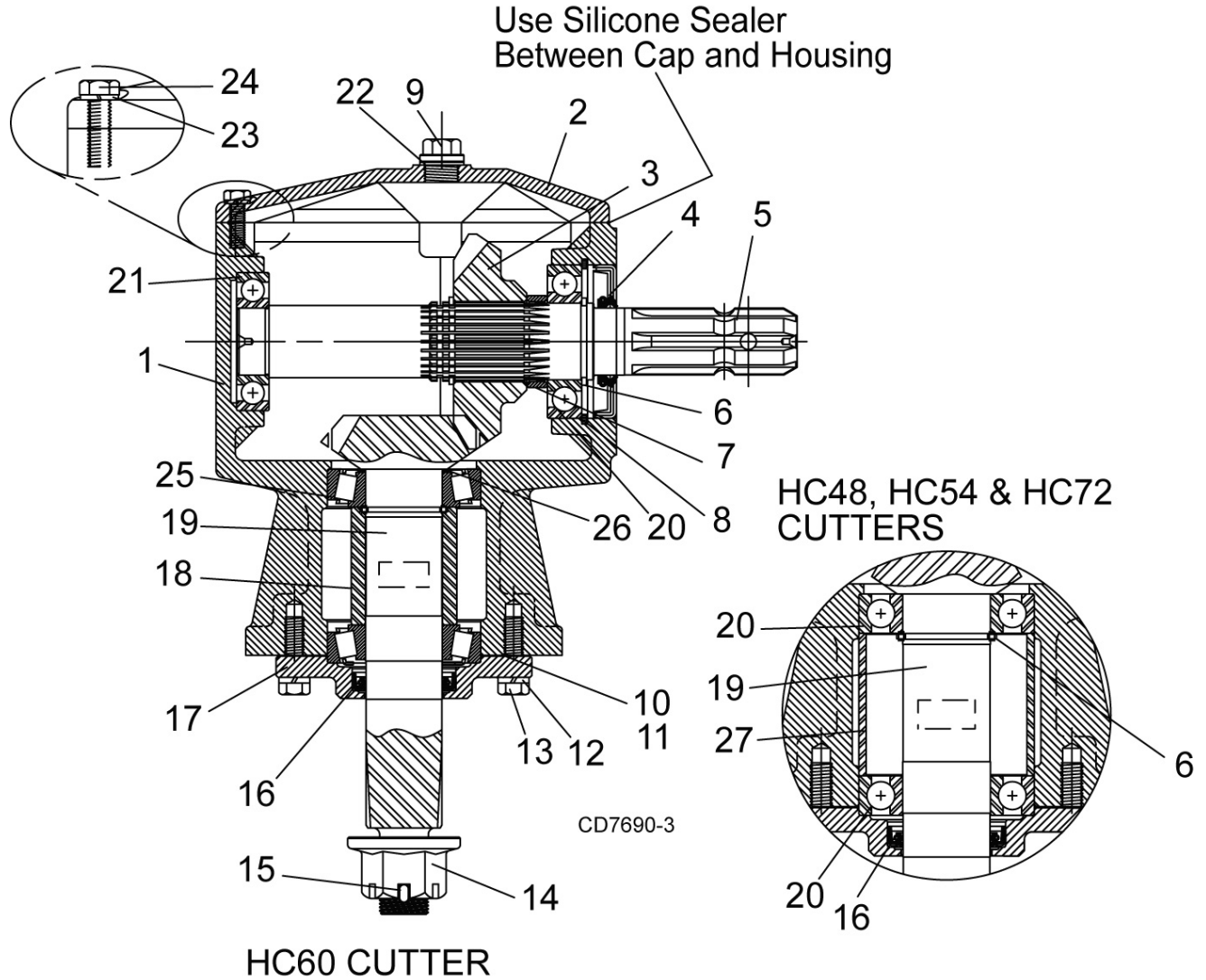
NSS Not Serviced Separately

\* Standard hardware, obtain locally

# 38 Parts

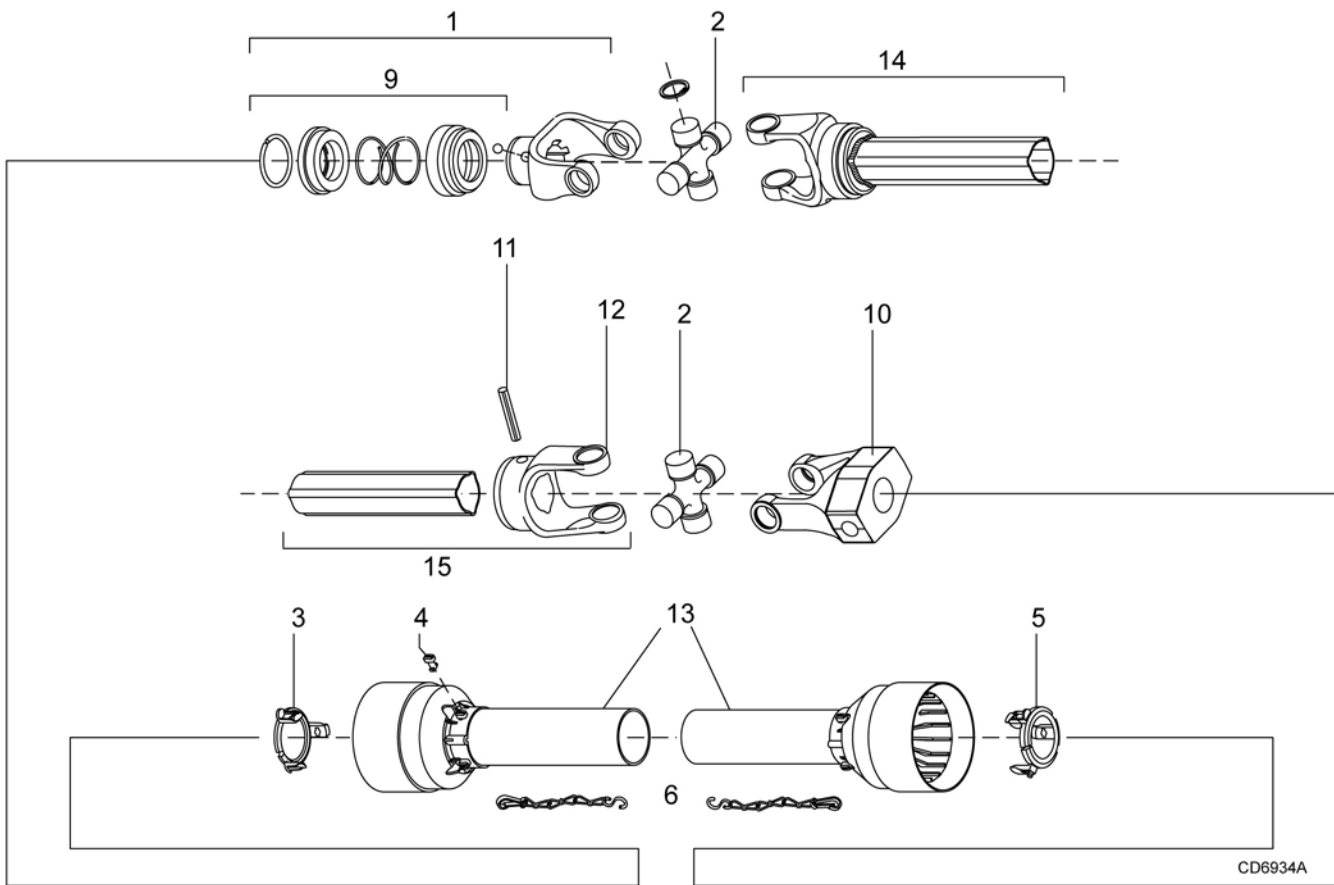
(Rev. 8/29/2011)  
MAN0670 (11/16/2007)

## GEARBOX ASSEMBLY (CAST/CROWN TOP)



REF	PART	QTY	DESCRIPTION	REF	PART	QTY	DESCRIPTION
A	1032587	1	Gearbox repair assembly ( <b>HC48 &amp; HC60, Ball Bearing</b> )	12	----	4	Lock washer
A	1032588	1	Gearbox repair assembly ( <b>HC60, Tapered Bearing</b> )	13	----	4	M10 x 1.5 x 25 Cap screw
A	1011794	1	Gearbox repair assembly ( <b>HC72, Ball Bearing</b> )	14	1018331	1	1" - 14 Slotted flange nut
1	----	1	Housing	15	----	1	Cotter pin
2	1019632	1	Inspection cover	16	1018328	1	Output seal
3	----	1	22 Tooth gear	17	----	1	Output cap
4	1018327	1	Input seal	18	----	1	Output bearing spacer
5	----	1	Input shaft	19	----	1	15-Tooth output shaft and pinion
6	----	1	Retaining ring	20	1018326	3	Ball bearing
7	----	1	Gear spacer	21	1018325	1	Ball bearing
8	----	1	Retaining ring	22	----	2	Sealing washer w/plug
9	1011780	1	Vent plug and washer	23	----	6	Lock washer
10	1018329	A/R	Output gasket (0.13)	24	----	6	M8 x 1.5 x 25 Cap screw
11	1018330	A/R	Output gasket (0.30)	25	57478	2	Bearing Cup and Cone
				26	1032963	1	Shim Kit
				27	----	1	Outerr Bearing Spacer

## HC48 SHEAR BOLT DRIVELINE ASSEMBLY



CD6934A

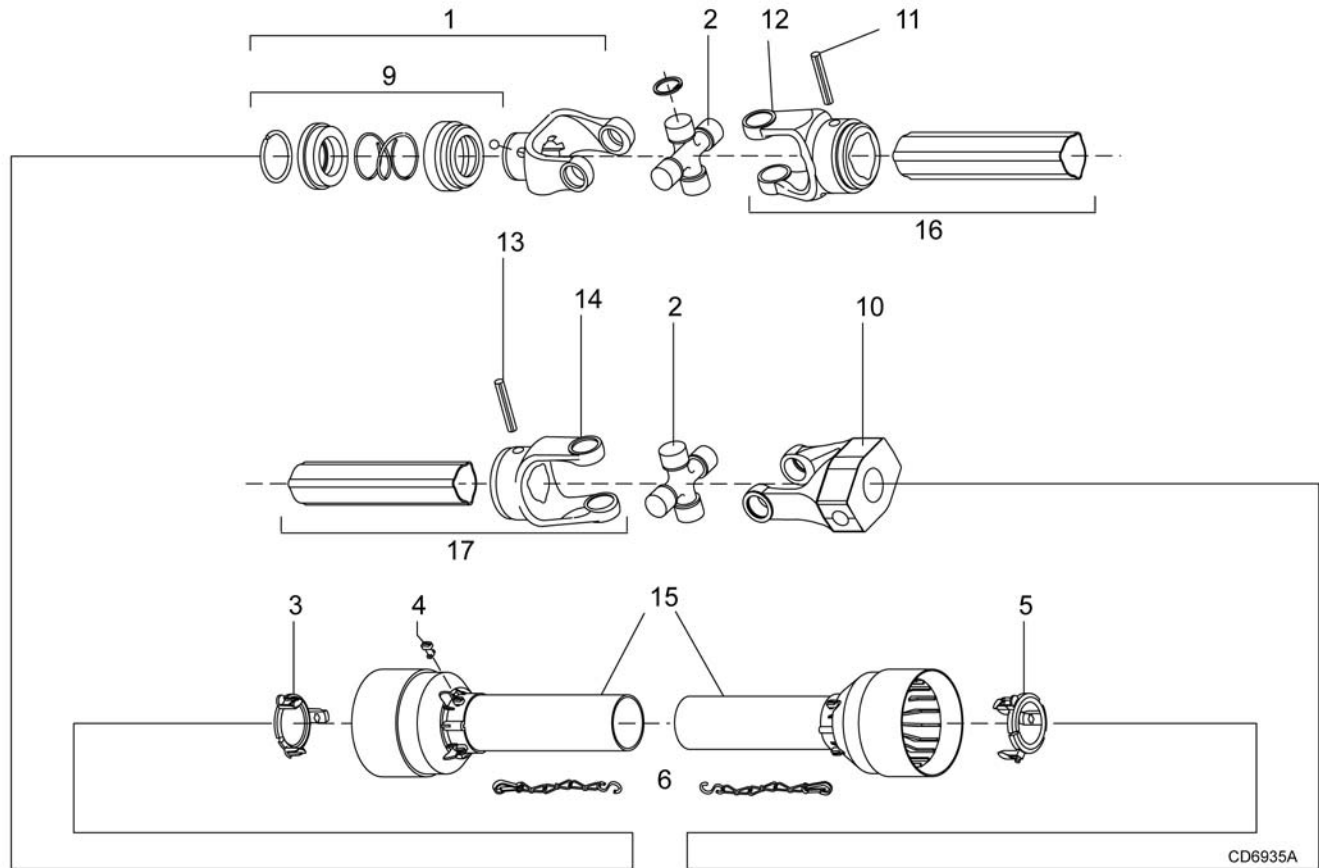
REF	PART	QTY	DESCRIPTION	REF	PART	QTY	DESCRIPTION
A	1009509	1	Complete 540 driveline asy	9	1001340	1	Lock collar repair kit
1	1001300	1	Complete collar yoke C12 1-3/8 - 6	10	1019445	1	Special drive yoke
2	38478	2	Cross & bearing kit	11	1001305	1	Flexible pin
3	1019442	1	Outer cone fix ring	12	1001306	1	Inner tube yoke
4	30922	6	Shield retainer clip	13	1021324	1	Shield, complete
5	1019444	1	Inner cone fix ring	14	30926	1	Outer yoke & tube (must be cut to length)
6	30917	2	Chain shield tether	15	30932	1	Inner yoke & tube (must be cut to length)

**40 Parts**

(Rev. 6/27/2008)  
MAN0670 (11/16/2007)



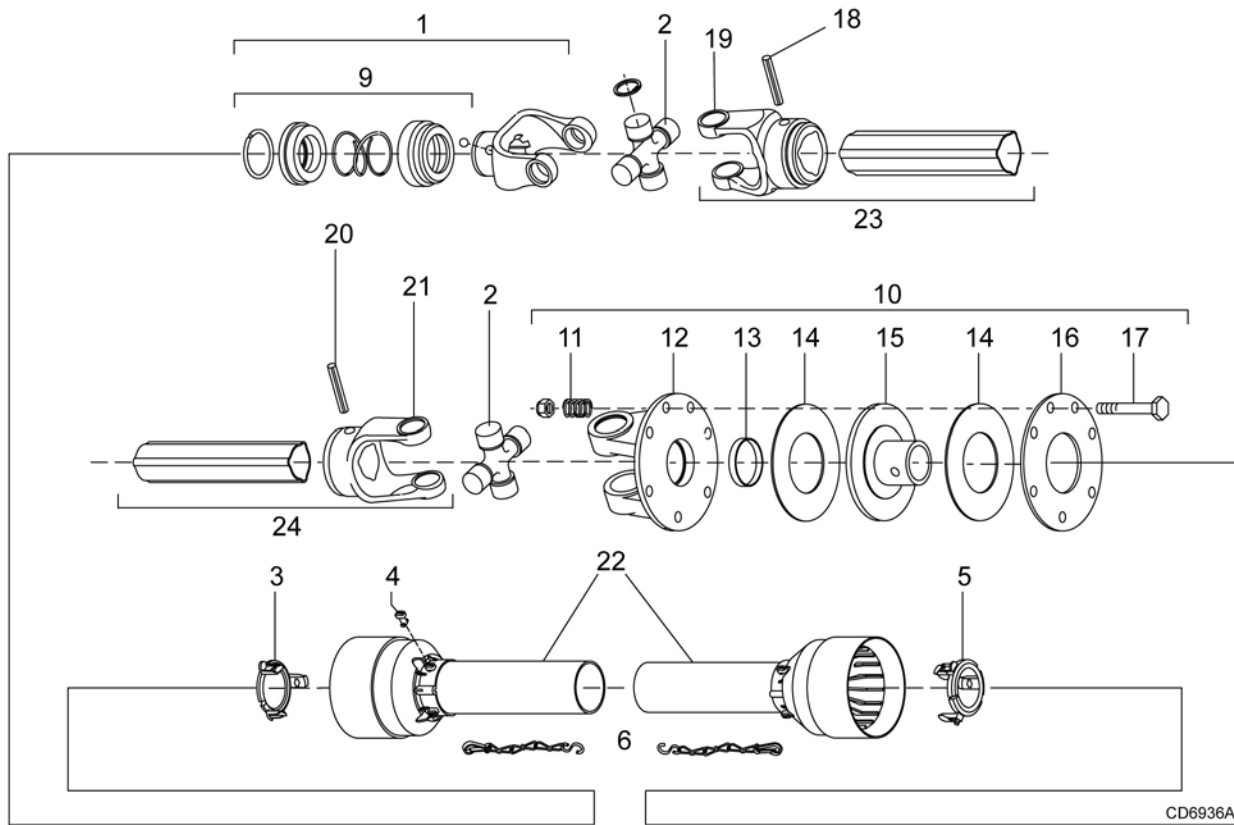
## HC54, HC60, HC72 SHEAR BOLT DRIVELINE ASSEMBLY



CD6935A

REF	PART	QTY	DESCRIPTION	REF	PART	QTY	DESCRIPTION
A	1009510	1	Complete 540 driveline <b>(HC54, HC60)</b>	11	1001302	1	Flexible pin
A	1024217	1	Complete 540 driveline <b>(HC72)</b>	12	1001301	1	Outer yoke tube
1	1001300	1	Complete collar yoke C12 1-3/8 - 6	13	1001305	1	Flexible pin
2	38478	2	Cross & bearing kit	14	1001306	1	Inner tube yoke
3	1019442	1	Outer cone fix ring	15	1021550	1	Shield, complete <b>(HC54, HC60)</b>
4	30922	6	Shield retainer clip	15	1024223	1	Shield, complete <b>(HC72)</b>
5	1019444	1	Inner cone fix ring	16	30926	1	Outer yoke & tube (must be cut to length)
6	30917	2	Chain shielding tether	17	30932	1	Inner yoke & tube (must be cut to length)
9	1001340	1	Lock collar repair kit				
10	1019445	1	Special drive yoke				

## HC48, HC54, HC60 SLIP CLUTCH DRIVELINE ASSEMBLY (OPTIONAL)



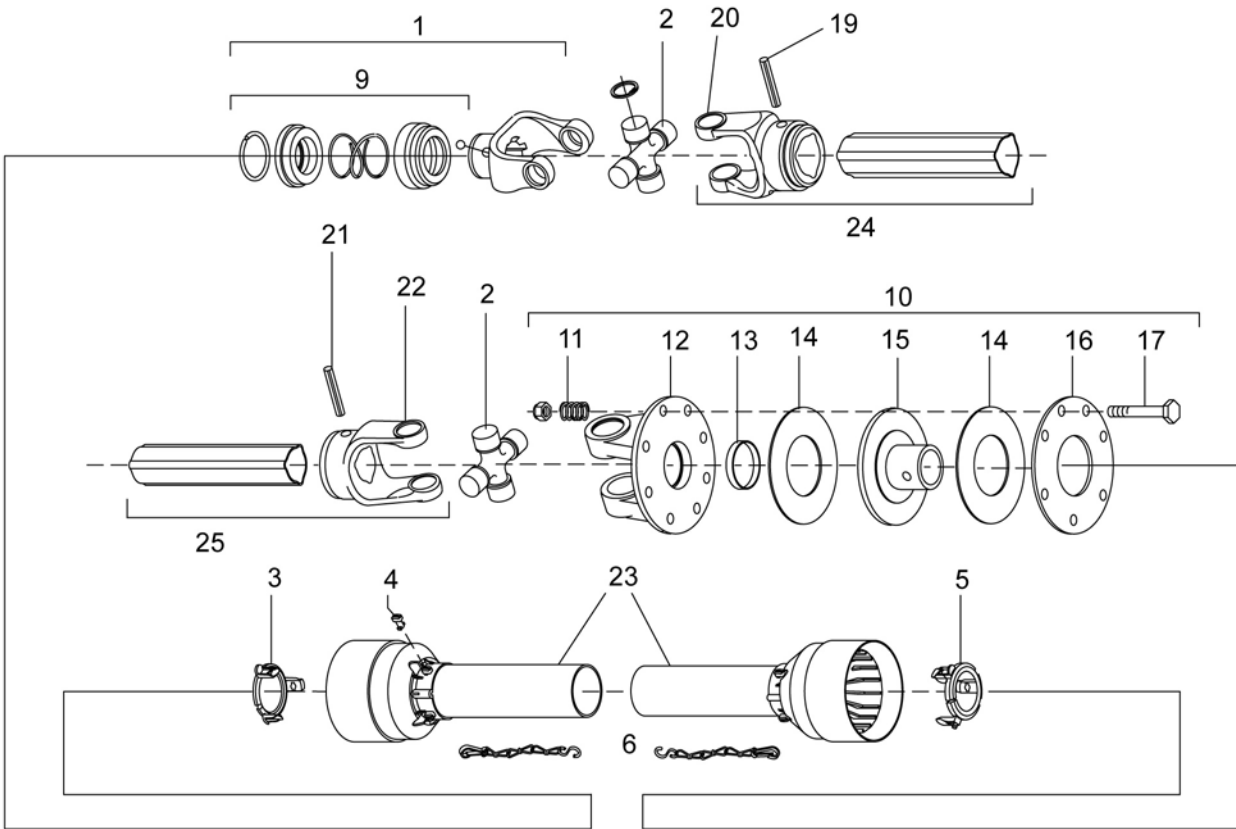
CD6936A

REF	PART	QTY	DESCRIPTION	REF	PART	QTY	DESCRIPTION
A	1020900	1	Complete 540 driveline assembly	14	1001314	2	Lining ring
1	1001300	1	Complete collar yoke C12 1-3/8 - 6	15	1019448	1	Special hub F10
2	38478	2	Cross & bearing kit	16	1001317	1	Pressure plate
3	1019442	1	Outer cone fix ring	17	1001318	8	Bolt & nut M10 x 80
4	30922	6	Shield retainer clip	18	1001302	1	Flexible pin
5	1019444	1	Inner cone fix ring	19	1001301	1	Outer yoke tube
6	30917	2	Chain shield tether	20	1001305	1	Flexible pin
9	1001340	1	Lock collar repair kit	21	1001306	1	Inner tube yoke
10	1019446	1	Special friction clutch	22	1021551	1	Shield, complete
11	1001311	8	Spring	23	30926	1	Outer yoke & tube (must be cut to length)
12	1019447	1	Flanged yoke	24	30932	1	Inner yoke & tube (must be cut to length)
13	1001313	1	Bushing				

**42 Parts**

(Rev. 6/27/2008)  
MAN0670 (11/16/2007)

## HC72 SLIP CLUTCH DRIVELINE ASSEMBLY



CD6937A

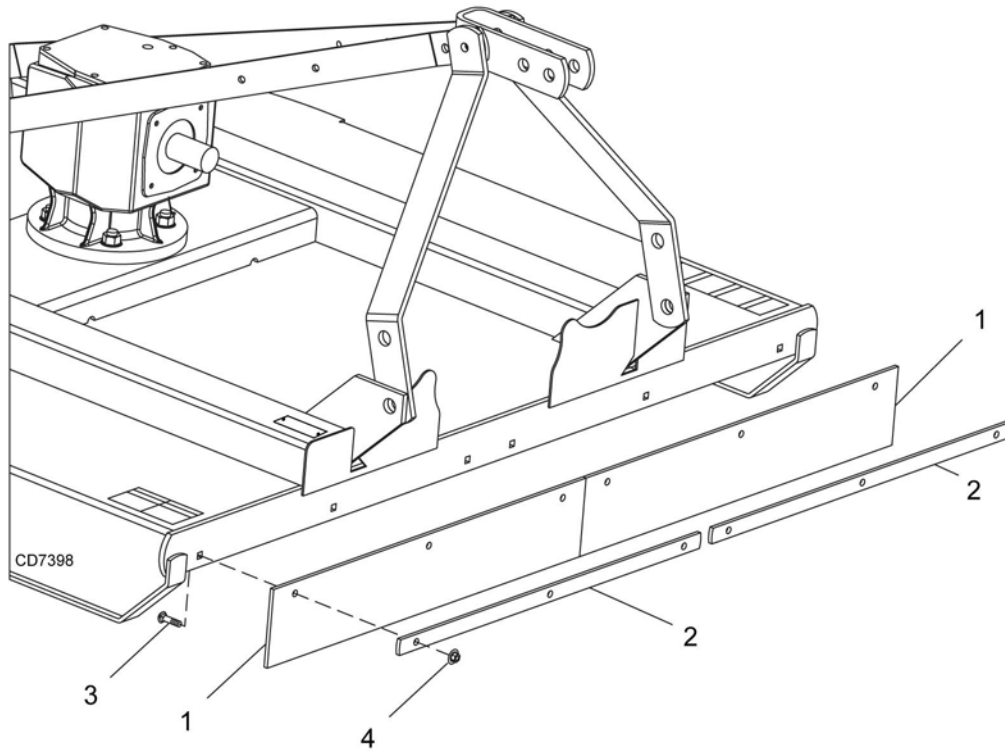
REF	PART	QTY	DESCRIPTION	REF	PART	QTY	DESCRIPTION
A	1024218	1	Complete 540 driveline asy	14	1001314	2	Lining ring
1	1001300	1	Complete collar yoke C12 1-3/8 - 6	15	1019448	1	Hub F10 (special)
2	38478	2	Cross and bearing kit	16	1001317	1	Pressure plate
3	1019442	1	Outer cone fix ring	17	1001318	8	Bolt & nut M10 x 80
4	30922	6	Shield retainer clip	19	1001302	1	Flexible pin
5	1019444	1	Inner cone fix ring	20	1001301	1	Outer yoke tube
6	30917	2	Chain-shield tether	21	1001305	1	Flexible pin
9	1001340	1	Lock collar repair kit	22	1001306	1	Inner tube yoke
10	1019446	1	Friction clutch (special)	23	1021552	1	Shield, complete
11	1001311	8	Spring	24	30926	1	Outer yoke & tube (must be cut to length)
12	1019447	1	Flanged yoke	25	30932	1	Inner yoke & tube (must be cut to length)
13	1001313	1	Bushing				

(Rev. 6/27/2008)

MAN0670 (11/16/2007)

# Parts 43

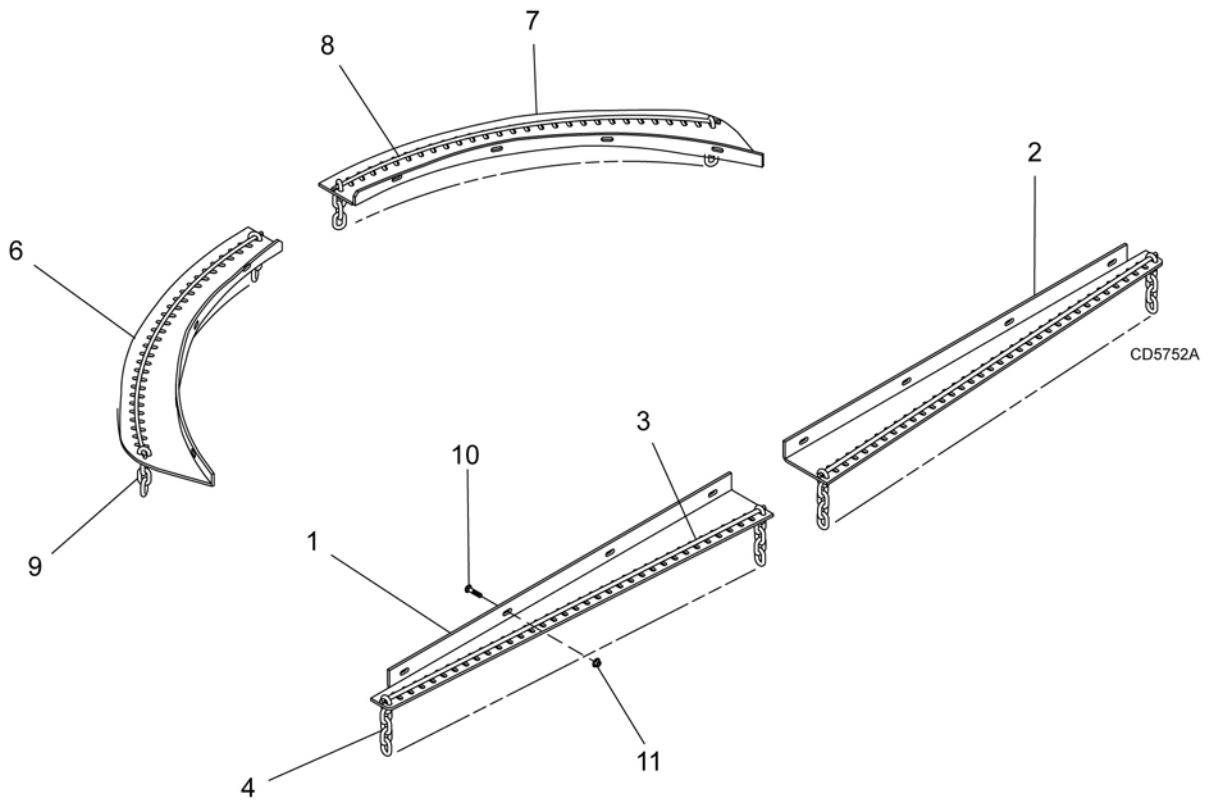
## FRONT RUBBER SHIELDING (STANDARD)



REF	PART	QTY	DESCRIPTION	REF	PART	QTY	DESCRIPTION
A	1024665	1	Rubber shield kit - <b>HC48</b> (includes items 1-4)	1	1026540	2	Rubber deflector 31.25 - <b>HC60</b>
A	1024666	1	Rubber shield kit - <b>HC54</b> (includes items 1-4)	1	1024178	2	Rubber deflector 37.00 - <b>HC72</b>
A	1024667	1	Rubber shield kit - <b>HC60</b> (includes items 1-4)	2	1024661	2	Link .25 x 1.00 x 23.50 - <b>HC48</b>
A	1024668	1	Rubber shield kit - <b>HC72</b> (includes items 1-4)	2	1018044	2	Link .25 x 1.00 x 27.00 - <b>HC54</b>
1	1017720	2	Rubber deflector 25.0 - <b>HC48</b>	2	1026541	2	Link .25 x 1.00 x 28.5 - <b>HC60</b>
1	1018043	2	Rubber deflector 28.0 - <b>HC54</b>	2	1024179	2	Link .25 x 1.00 x 34.5 - <b>HC72</b>
				3	20973 *	8	3/8 NC x 1-1/4 Carriage bolt
				4	14350 *	8	3/8 NC Flange hex nut

\* Standard hardware; obtain locally

## FRONT & REAR CHAIN SHIELDING (OPTIONAL)

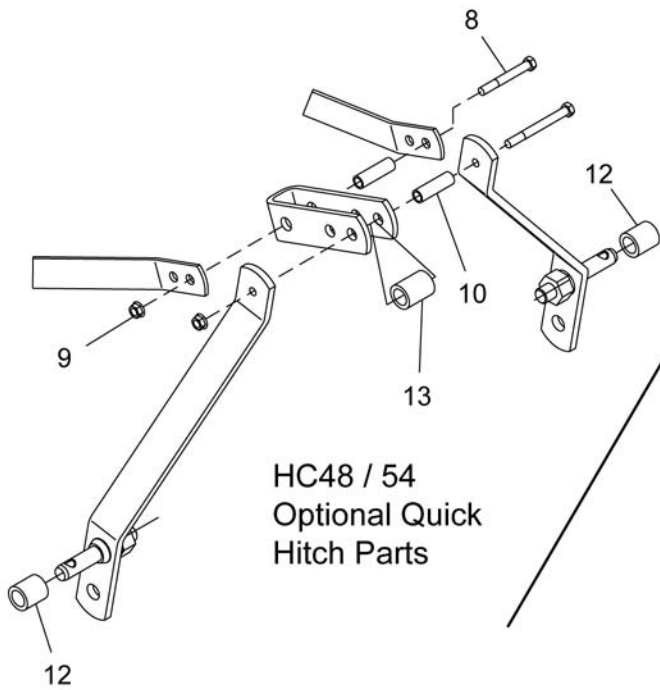


REF	QTY	PART HC48	PART HC54	PART HC60	PART HC72	DESCRIPTION
1	1	1018025	1027362	1027356	1027350	Right front chain plate
2	1	1027363	57144	1027357	1027351	Left front chain plate
3	2	1003644	1003645	1003645	1003646	.243 Dia. bent pin (front)
4	AR	3994	3994	3994	3994	5/16 - 5 Link chain (front)
6	1	1018028	1027369	1027361	1027355	Right rear chain plate
7	1	1018027	1027364	1027358	1027352	Left rear chain plate
8	2	57249	57249	57249	57249	.243 Dia. rolled bent pin (rear)
9	AR	4069	4069	4069	4069	5/16 - 4 Link chain (rear)
10	16	6697 *	6697 *	6697 *	6697 *	3/8 NC x 1 Carriage bolt
11	16	14350 *	14350 *	14350 *	14350 *	3/8 NC Flange hex nut

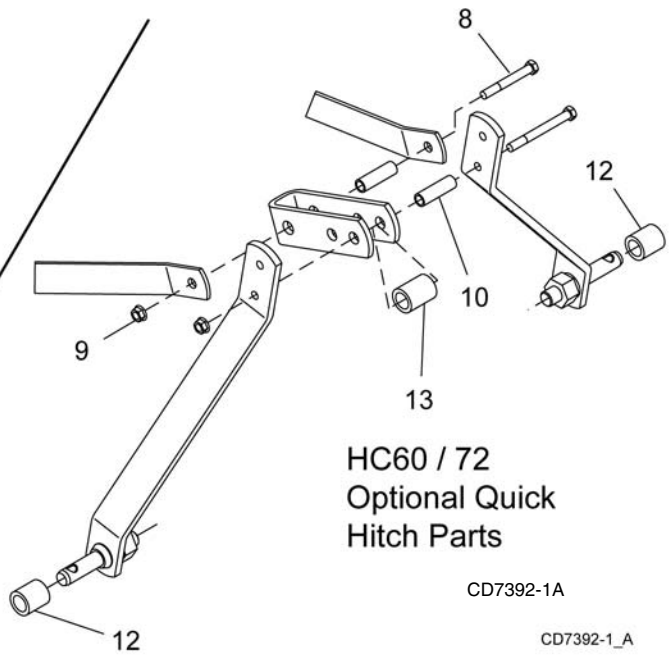
AR As Required

\* Standard hardware, obtain locally

## QUICK HITCH HARDWARE (OPTIONAL)



HC48 / 54  
Optional Quick  
Hitch Parts



HC60 / 72  
Optional Quick  
Hitch Parts

CD7392-1A

CD7392-1\_A

REF	PART	QTY	DESCRIPTION
8	10380	1	1/2 NC x 4 Cap screw
9	11900	1	1/2 NC Flange lock nut
10	33657	1	1/2 x 3/4 x 2-13/16 Sleeve
12	38214	2	.91 x 1.44 x 1.25 Sleeve
13	1003614	1	.81 x 1.25 x 1.81 Sleeve
-	1026566	1	Quick hitch kit

**46 Parts**

MAN0670 (11/16/2007)

# BOLT TORQUE CHART

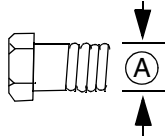
Always tighten hardware to these values unless a different torque value or tightening procedure is listed for a specific application.

Fasteners must always be replaced with the same grade as specified in the manual parts list.

Always use the proper tool for tightening hardware: SAE for SAE hardware and Metric for metric hardware.

Make sure fastener threads are clean and you start thread engagement properly.

All torque values are given to specifications used on hardware defined by SAE J1701 MAR 99 & J1701M JUL 96.



## SAE SERIES TORQUE CHART



SAE Grade 2  
(No Dashes)

SAE Bolt Head Identification

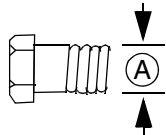


SAE Grade 5  
(3 Radial Dashes)



SAE Grade 8  
(6 Radial Dashes)

Ⓐ Diameter (Inches)	Wrench Size	MARKING ON HEAD					
		SAE 2		SAE 5		SAE 8	
		lbs-ft	N-m	lbs-ft	N-m	lbs-ft	N-m
1/4"	7/16"	6	8	10	13	14	18
5/16"	1/2"	12	17	19	26	27	37
3/8"	9/16"	23	31	35	47	49	67
7/16"	5/8"	36	48	55	75	78	106
1/2"	3/4"	55	75	85	115	120	163
9/16"	13/16"	78	106	121	164	171	232
5/8"	15/16"	110	149	170	230	240	325
3/4"	1-1/8"	192	261	297	403	420	569
7/8"	1-5/16"	306	416	474	642	669	907
1"	1-1/2"	467	634	722	979	1020	1383



## METRIC SERIES TORQUE CHART



8.8  
Metric  
Grade 8.8

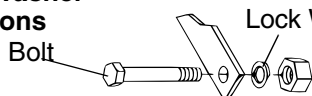
Metric Bolt Head Identification



10.9  
Metric  
Grade 10.9

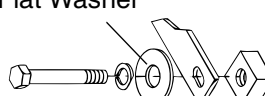
Ⓐ Diameter & Thread Pitch (Millimeters)	Wrench Size	Coarse Thread				Fine Thread				Ⓐ Diameter & Thread Pitch (Millimeters)
		Marking on Head								
		Metric 8.8		Metric 10.9		Metric 8.8		Metric 10.9		
		N-m	lbs-ft	N-m	lbs-ft	N-m	lbs-ft	N-m	lbs-ft	
6 x 1.0	10 mm	8	6	11	8	8	6	11	8	6 x 1.0
8 x 1.25	13 mm	20	15	27	20	21	16	29	22	8 x 1.0
10 x 1.5	16 mm	39	29	54	40	41	30	57	42	10 x 1.25
12 x 1.75	18 mm	68	50	94	70	75	55	103	76	12 x 1.25
14 x 2.0	21 mm	109	80	151	111	118	87	163	120	14 x 1.5
16 x 2.0	24 mm	169	125	234	173	181	133	250	184	16 x 1.5
18 x 2.5	27 mm	234	172	323	239	263	194	363	268	18 x 1.5
20 x 2.5	30 mm	330	244	457	337	367	270	507	374	20 x 1.5
22 x 2.5	34 mm	451	332	623	460	495	365	684	505	22 x 1.5
24 x 3.0	36 mm	571	421	790	583	623	459	861	635	24 x 2.0
30 x 3.0	46 mm	1175	867	1626	1199	1258	928	1740	1283	30 x 2.0

### Typical Washer Installations



Lock Washer

Flat Washer

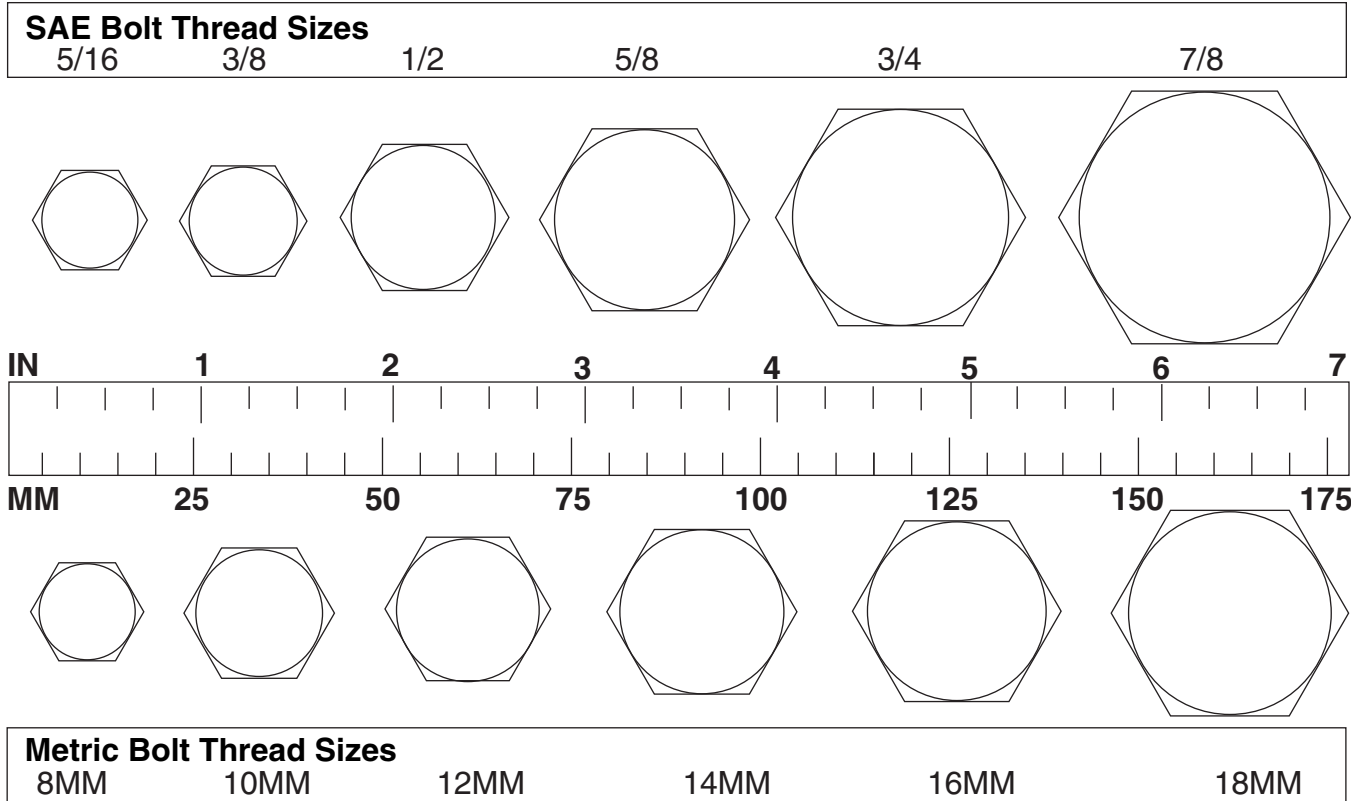


8/9/00



# BOLT SIZE CHART

**NOTE:** Chart shows bolt thread sizes and corresponding head (wrench) sizes for standard SAE and metric bolts.



## ABBREVIATIONS

AG ..... Agriculture  
 ASABE ..... American Society of Agricultural & Biological Engineers (formerly ASAE)  
 ASAE..... American Society of Agricultural Engineers  
 ATF.....Automatic Transmission Fluid  
 BSPP..... British Standard Pipe Parallel  
 BSPTM..... British Standard Pipe Tapered Male  
 CV ..... Constant Velocity  
 CCW..... Counter-Clockwise  
 CW ..... Clockwise  
 F ..... Female  
 FT..... Full Thread  
 GA ..... Gauge  
 GR (5, etc.)..... Grade (5, etc.)  
 HHCS ..... Hex Head Cap Screw  
 HT ..... Heat-Treated  
 JIC..... Joint Industry Council 37° Degree Flare  
 LH..... Left Hand  
 LT ..... Left  
 m ..... Meter  
 mm ..... Millimeter  
 M ..... Male

MPa ..... Mega Pascal  
 N ..... Newton  
 NC..... National Coarse  
 NF ..... National Fine  
 NPSM ..... National Pipe Straight Mechanical  
 NPT.....National Pipe Tapered  
 NPT SWF..... National Pipe Tapered Swivel Female  
 ORBM ..... O-Ring Boss - Male  
 P ..... Pitch  
 PBY.....Power-Beyond  
 psi ..... Pounds per Square Inch  
 PTO.....Power Take Off  
 QD ..... Quick Disconnect  
 RH..... Right Hand  
 ROPS..... Roll-Over Protective Structure  
 RPM.....Revolutions Per Minute  
 RT ..... Right  
 SAE..... Society of Automotive Engineers  
 UNC ..... Unified Coarse  
 UNF ..... Unified Fine  
 UNS ..... Unified Special

# INDEX

## ASSEMBLY

Dealer Set-Up Instructions 30

## DEALER CHECK LISTS

Delivery (Dealer's Responsibility) 33  
Pre-Delivery (Dealer's Responsibility) 33

## DEALER SERVICE

Crossbar  
Installation 27  
Removal 26  
Gearbox Maintenance 23  
Horizontal Leak Repair 24  
Seal Installation 23  
Seal Replacement 23  
Vertical Shaft Repair 24  
Gearbox Repair  
Disassemble Gearbox 24  
Reassemble Gearbox 25  
Reinstall Gearbox 26  
Remove Gearbox 24  
Universal Joint  
Assembly 29  
Disassembly 28  
Repair 28

## GENERAL

Abbreviations 48  
Bolt Size Chart 48  
Bolt Torque Chart 47  
General Information 4  
Introduction 2  
Obtaining Replacement Manuals 2  
Specifications 4  
Table of Contents 3  
Warranty  
Product 51  
Replacement Parts 52

## OPERATION

Attach Cutter to Tractor 12  
Quick Hitch 14  
Standard Hitch 14  
Cutting Height Adjustment 16

## OPERATION (CONTINUED)

Driveline  
Driveline Adjustment 15  
Driveline Installation (Tractor PTO) 15  
Driveline Interference Check 16  
Shorten Driveline 15  
Operating Technique 17  
Pre-Operation Check List-  
(Owner's Responsibility) 17  
Quick Hitch Assembly (HC48 / HC54) 13  
Quick Hitch Assembly (HC60 / HC72) 14  
Shredding Material 17  
Storage 17  
Top Link Adjustment 13  
Tractor Stability 12

## OWNER SERVICE

Blade Servicing  
Blade Installation 19  
Blade Removal 19  
Blade Sharpening 20  
Blocking Method 18  
Cleaning  
After Each Use 21  
Periodically or Before Extended Storage 21  
Driveline Shear Bolt Replacement 21  
Lubrication Information 18  
Driveline 18  
Gearbox 18  
Lubrication Diagram 19  
Shielding Repair 21  
Slip Clutch Adjustment 20

## PARTS

Index to Parts Lists 35

## SAFETY

Check Lists  
Delivery (Dealer's Responsibility) 33  
Pre-Delivery (Dealer's Responsibility) 33  
Pre-Operation (Owner's Responsibility) 17  
Free Mower Safety Video Order Form 5, 6  
Safety & Instructional Decals 10, 11  
Safety Rules 7, 8, 9  
Safety Symbols Explained 2

## TROUBLESHOOTING

Mowing Conditions 22

# NOTES





# WARRANTY

All Models Except Mow'n Machine™ Zero-Turn Mowers

Please Enter Information Below and Save for Future Reference.

Date Purchased: \_\_\_\_\_ From (Dealer): \_\_\_\_\_

Model Number: \_\_\_\_\_ Serial Number: \_\_\_\_\_

Woods Equipment Company ("WOODS") warrants this product to be free from defect in material and workmanship. Except as otherwise set forth below, the duration of this Warranty shall be for TWELVE (12) MONTHS COMMENCING ON THE DATE OF DELIVERY OF THE PRODUCT TO THE ORIGINAL PURCHASER.

All current model loaders and backhoes are warranted for two (2) years from the date of delivery to the original purchaser.

The warranty periods for specific parts or conditions are listed below:

Part or Condition Warranted	Model Number	Duration (from date of delivery to the original purchaser)
Gearbox Seals	All units listed below	2 years
Gearbox components	BW1260, BW1620, BW1800, BW2400	8 years
	BW240HD, BW180HD, BW180HB, BW126HB	7 years
	BB48X, BB60X, BB72X, BB84X, BB600X, BB720X, BB840X, BB6000X, BB7200X, BB8400X, DS1260, DSO1260, DS1440, TS1680, BW126-3, BW180-3, BW240	6 years
	PHD25, PHD35, PHD65, PHD95, 2162, 3240, DS96, DS120, RCC42, RM550-2, RM660-2, RD990X, PRD6000, PRD7200, PRD8400, S15CD, S20CD, S22CD, S25CD, S27CD, BW180LH, TC/R74, TC/R68, TC/R60, TBW144, TBW180, TBW204	5 years
	RDC54, RD60, RD72, TBW150C, TS/R60, TS/R52, TS/R44	3 years (1 year if used in rental or commercial applications)
Blade spindles	RM550-2, RM660-2, RD990X, PRD6000, PRD7200, PRD8400, TBW144, TBW180, TBW204	3 years
Rust-through	BB600, BB720, BB840, BB6000, BB7200, BB8400, BW126-3, BW126HB, BW180-3, BW180HB, BW180HD, BW1260, BW1800, BW240, BW240HD, 2162, 3240, DS1260, DSO1260, DS1440, TS1680	10 years

Under no circumstances will this Warranty apply in the event that the product, in the good faith opinion of WOODS, has been subjected to improper operation, improper maintenance, misuse, or an accident. This Warranty does not apply in the event that the product has been materially modified or repaired by someone other than WOODS, a WOODS authorized dealer or distributor, and/or a WOODS authorized service center. This Warranty does not cover normal wear or tear, or normal maintenance items. This Warranty also does not cover repairs made with parts other than those obtainable through WOODS.

This Warranty is extended solely to the original purchaser of the product. Should the original purchaser sell or otherwise transfer this product to a third party, this Warranty does not transfer to the third party purchaser in any way. There are no third party beneficiaries of this Warranty.

WOODS makes no warranty, express or implied, with respect to engines, batteries, tires or other parts or accessories not manufactured by WOODS. Warranties for these items, if any, are provided separately by their respective manufacturers.

WOODS' obligation under this Warranty is limited to, at WOODS' option, the repair or replacement, free of charge, of the product if WOODS, in its sole discretion, deems it to be defective or in noncompliance with this Warranty. **The product must be returned to WOODS with proof of purchase within thirty (30) days after such defect or noncompliance is discovered or should have been discovered, routed through the dealer and distributor from whom the purchase was made, transportation charges prepaid.** WOODS shall complete such repair or replacement within a reasonable time after WOODS receives the product. **THERE ARE NO OTHER REMEDIES UNDER THIS WARRANTY. THE REMEDY OF REPAIR OR REPLACEMENT IS THE SOLE AND EXCLUSIVE REMEDY UNDER THIS WARRANTY.**

THERE ARE NO WARRANTIES WHICH EXTEND BEYOND THE DESCRIPTION ON THE FACE OF THIS WARRANTY. WOODS MAKES NO OTHER WARRANTY, EXPRESS OR IMPLIED, AND WOODS SPECIFICALLY DISCLAIMS ANY IMPLIED WARRANTY OF MERCHANTABILITY AND/OR ANY IMPLIED WARRANTY OF FITNESS FOR A PARTICULAR PURPOSE.

**WOODS shall not be liable for any incidental or consequential losses, damages or expenses, arising directly or indirectly from the product, whether such claim is based upon breach of contract, breach of warranty, negligence, strict liability in tort or any other legal theory.** Without limiting the generality of the foregoing, Woods specifically disclaims any damages relating to (i) lost profits, business, revenues or goodwill; (ii) loss of crops; (iii) loss because of delay in harvesting; (iv) any expense or loss incurred for labor, supplies, substitute machinery or rental; or (v) any other type of damage to property or economic loss.

This Warranty is subject to any existing conditions of supply which may directly affect WOODS' ability to obtain materials or manufacture replacement parts.

No agent, representative, dealer, distributor, serviceperson, salesperson, or employee of any company, including without limitation, WOODS, its authorized dealers, distributors and service centers, authorized to alter, modify or enlarge this Warranty. Answers to any questions regarding warranty service can be obtained by contacting:

**ALITEC™**

**BMP®**

**CENTRAL FABRICATORS®**

**GANNON®**

**GILL®**

**WAIN-ROY®**

**WOODS®**

**Woods Equipment Company**

2606 South Illinois Route 2  
Post Office Box 1000  
Oregon, Illinois 61061 USA

800-319-6637 tel  
800-399-6637 fax  
www.WoodsEquipment.com





**WOODS®**

**ALITEC™**  
**BMP®**  
**CENTRAL FABRICATORS®**  
**GANNON®**  
**GILL®**  
**WAIN-ROY®**  
**WOODS®**



## WARRANTY

(Replacement Parts For All Models Except Mow'n Machine™  
Zero-Turn Mowers and Woods Boundary™ Utility Vehicles)

Woods Equipment Company ("WOODS") warrants this product to be free from defect in material and workmanship for a period of ninety (90) days from the date of delivery of the product to the original purchaser with the exception of V-belts, which will be free of defect in material and workmanship for a period of 12 months.

Under no circumstances will this Warranty apply in the event that the product, in the good faith opinion of WOODS, has been subjected to improper operation, improper maintenance, misuse, or an accident. This Warranty does not cover normal wear or tear, or normal maintenance items.

This Warranty is extended solely to the original purchaser of the product. Should the original purchaser sell or otherwise transfer this product to a third party, this Warranty does not transfer to the third party purchaser in any way. There are no third party beneficiaries of this Warranty.

WOODS' obligation under this Warranty is limited to, at WOODS' option, the repair or replacement, free of charge, of the product if WOODS, in its sole discretion, deems it to be defective or in noncompliance with this Warranty. **The product must be returned to WOODS with proof of purchase within thirty (30) days after such defect or noncompliance is discovered or should have been discovered, routed through the dealer and distributor from whom the purchase was made, transportation charges prepaid.** WOODS shall complete such repair or replacement within a reasonable time after WOODS receives the product. THERE ARE NO OTHER REMEDIES UNDER THIS WARRANTY. THE REMEDY OF REPAIR OR REPLACEMENT IS THE SOLE AND EXCLUSIVE REMEDY UNDER THIS WARRANTY.

THERE ARE NO WARRANTIES WHICH EXTEND BEYOND THE DESCRIPTION ON THE FACE OF THIS WARRANTY. WOODS MAKES NO OTHER WARRANTY, EXPRESS OR IMPLIED, AND WOODS SPECIFICALLY DISCLAIMS ANY IMPLIED WARRANTY OF MERCHANTABILITY AND/OR ANY IMPLIED WARRANTY OF FITNESS FOR A PARTICULAR PURPOSE.

**WOODS shall not be liable for any incidental or consequential losses, damages or expenses, arising directly or indirectly from the product, whether such claim is based upon breach of contract, breach of warranty, negligence, strict liability in tort or any other legal theory.** Without limiting the generality of the foregoing, Woods specifically disclaims any damages relating to (i) lost profits, business, revenues or goodwill; (ii) loss of crops; (iii) loss because of delay in harvesting; (iv) any expense or loss incurred for labor, supplies, substitute machinery or rental; or (v) any other type of damage to property or economic loss.

This Warranty is subject to any existing conditions of supply which may directly affect WOODS' ability to obtain materials or manufacture replacement parts.

No agent, representative, dealer, distributor, service person, salesperson, or employee of any company, including without limitation, WOODS, its authorized dealers, distributors, and service centers, is authorized to alter, modify, or enlarge this Warranty.

Answers to any questions regarding warranty service and locations may be obtained by contacting:

**ALITEC™**  
**BMP®**  
**CENTRAL FABRICATORS®**  
**GANNON®**  
**GILL®**  
**WAIN-ROY®**  
**WOODS®**

**WOODS®**

## Free Manuals Download Website

<http://myh66.com>

<http://usermanuals.us>

<http://www.somanuals.com>

<http://www.4manuals.cc>

<http://www.manual-lib.com>

<http://www.404manual.com>

<http://www.luxmanual.com>

<http://aubethermostatmanual.com>

Golf course search by state

<http://golfingnear.com>

Email search by domain

<http://emailbydomain.com>

Auto manuals search

<http://auto.somanuals.com>

TV manuals search

<http://tv.somanuals.com>