

Model D4088 Drill Press Lathe Attachment Instruction Sheet



Phone #: (360) 734-3482 • Online Tech Support: tech-support@shopfox.biz • Web: www.shopfox.biz

Introduction

The Model D4088 Drill Press Lathe Attachment allows wooden workpieces to be turned on a drill press in the same manner as a wood lathe. Items like small pickets, legs, spindles, handles, dowels, and pins can be made. Fits drill press tables with T-nut slots or with slotted through holes as shown in **Figure 1**.

Specifications

Tool Rest Length	12"
Maximum Workpiece Length (if reversed)	24"
Maximum Workpiece Diameter6"
Shank Diameter of Screw and Spur Center	$\frac{3}{8}$ "
Construction Material	Steel
Shipping Weight	3.5 lbs.

Inventory

Refer to the list and **Figure 2** to inventory your package. If you can't find an item on this list, check the mounting locations or examine the packaging materials carefully. Occasionally we pre-install certain components for shipping purposes.

If any nonproprietary parts are missing (e.g. a nut or a washer), we will gladly replace them; or for the sake of expediency, replacements can be obtained at your local hardware store.

Description	Qty
A. Tool Rest	1
B. Screw Center	1
C. Spur Center	1
D. Hex Wrenches 5, 6mm	1 Ea
E. Cap Screw M6-1 x 20	1
F. Tool Rest Foot	1
G. Carriage Bolt M10-1.5 x 40	2
H. Cap Screw M8-1.25 x 20	1
I. Base and Live Center Assembly	1
J. Flat Washer 10mm	2
K. Hex Nut M10-1.5	2



Figure 1. D4088 Drill Press Lathe Attachment

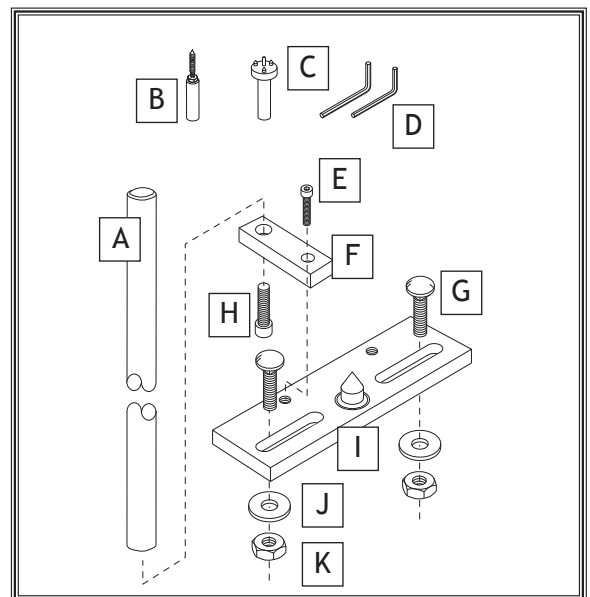

Figure 2. Inventory.

COPYRIGHT © JULY, 2010 BY WOODSTOCK INTERNATIONAL, INC.

WARNING: NO PORTION OF THIS MANUAL MAY BE REPRODUCED IN ANY SHAPE OR FORM WITHOUT THE WRITTEN APPROVAL OF WOODSTOCK INTERNATIONAL, INC.

#13043CR

Printed in China

Setup

If you need help with your new drill press lathe attachment, call our Tech Support at: (360) 734-3482.

Tools Needed

Wrench 17mm Qty 1

To setup the drill press lathe attachment, do these steps:

1. At each end of the workpiece, drill a $\frac{1}{8}$ " pilot hole $\frac{5}{8}$ " deep.
2. DISCONNECT DRILL PRESS FROM POWER!
3. Verify that the drill press table is properly leveled, and adjust as required.
4. Place the base so the live center is located in the center of the drill press table, as shown in **Figure 3**.
5. Fasten the base to the table with the carriage bolts, flat washers, and hex nuts, but do not fully tighten the hex nuts yet.
6. Install a drill bit or dowel in the chuck, lower the chuck so the tip of the drill bit or dowel just touches the point of the live center.
7. Move the base so the tip of the live center is aligned with the spindle centerline, as shown in **Figure 4**. Next, tighten the base hex nuts.
8. Retract the drill press spindle, and fasten the tool rest foot onto the base with the cap screw, as shown in **Figure 5**. Later, use the workpiece to estimate where to tighten the tool rest in place to achieve a gap of $\frac{1}{8}$ " to $\frac{1}{2}$ " between the workpiece and the tool rest.
9. Double check that all fasteners are tight.

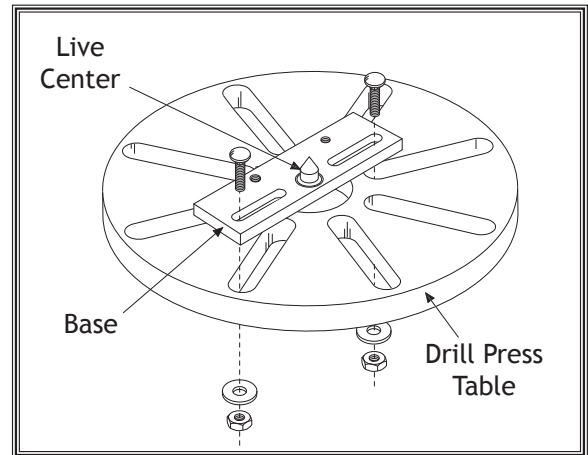

Figure 3. Mounting base to drill press table.

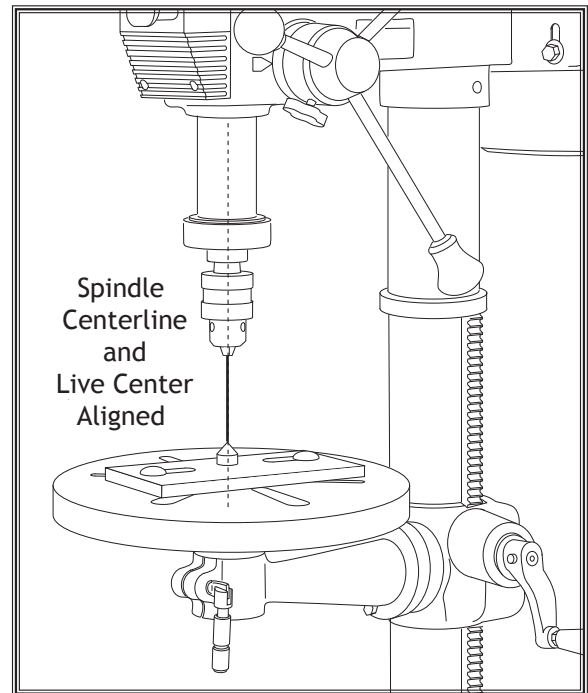

Figure 4. Live center to spindle alignment.

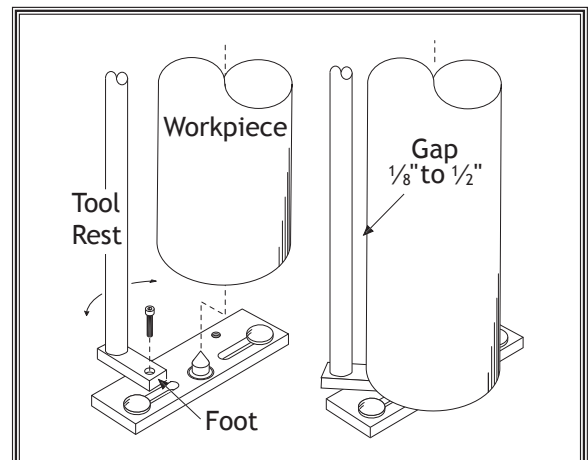

Figure 5. Tool rest installation and adjustment.

Operation Safety

Read and follow these safety precautions:

EYE/FACE PROTECTION. Wear eye protection and a face shield during all turning operations.

RESPIRATORY PROTECTION. Always wear a respirator when using this tool. Wood dust may cause allergies or long-term respiratory health problems.

AVOIDING ENTANGLEMENT. Keep long hair and loose clothing such as sleeves, belts, and jewelry items away from the workpiece and chuck.

WORKPIECE CONDITION. Always inspect the condition of your workpiece. NEVER turn stock with knots, splits, and other potentially dangerous conditions. All glued joints must have high quality bonds that will not fly apart during operation.

MOUNTING WORKPIECE. Before starting, be certain the drive and spur centers have been properly imbedded into the workpiece, and that the table is locked in place.

USING TOOL REST. NEVER attempt free-hand turning, you must always support the chisel on the tool rest, and keep the tool rest gap to 1/8" to 1/2" when ever possible.

TURNING SPEED. Select the correct tuning speed for your work before starting the drill press.

USING SHARP CHISELS. Keep chisels sharp. Dull chisels require more force to cut, causing tool chatter and grabbing hazards.

MATERIAL REMOVAL. Attempting to remove too much wood at once may cause the workpiece or chisel to eject causing severe injury.

NOTICE

If you have never used this type of machine or equipment before, WE STRONGLY RECOMMEND that you read books, trade magazines, or get formal training before beginning any projects. Regardless of the content in this section, Woodstock International will not be held liable for accidents caused by lack of training.

! WARNING

Damage to your face, lungs, and eyes could result from using this tool without proper protective gear. Always wear a face shield, safety glasses, and a respirator when using this drill press lathe attachment.

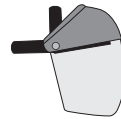

! WARNING

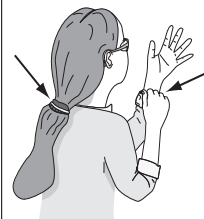

Loose hair and clothing could get caught in the spinning workpiece and cause serious personal injury. Keep loose clothing and long hair away from moving.

! CAUTION

No list of safety guidelines can be complete. Every shop environment is different. Always consider safety first, as it applies to your individual working conditions. Use this and other machinery with caution and respect. Failure to do so could result in serious personal injury, damage to equipment, or poor work results.

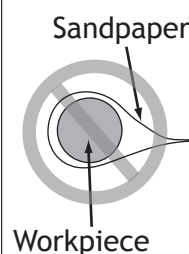

! CAUTION

Never wrap sandpaper around a moving workpiece, or your hands can be pulled in causing a an entanglement injury.

Operations

Follow all safety precautions in your drill press Owner's Manual and these instructions.

To use the drill press lathe attachment, do these steps:

1. Put on safety glasses, a face shield, and tie back loose clothing and hair.
2. DISCONNECT DRILL PRESS FROM POWER!
3. Install the required driving center into the upper end of the workpiece:
 - If the workpiece diameter is $\frac{3}{4}$ " or less, thread in the screw center.
 - If the workpiece diameter is $\frac{3}{4}$ "-3", tap in the spur center.
 - If the workpiece diameter is 3"-6", tap in a 2" diameter forstner bit as the drive center. You may have to slightly enlarge the pilot hole to accept the forstner bit pilot.
4. Place the workpiece pilot hole onto the live center tip, and hold the workpiece in place.
5. Without losing spindle alignment, crank the table up so the drive center shank enters the chuck and the live center seats in the pilot hole.
6. Clamp the drive center shank with the chuck, lock the table into position and make sure all fasteners are tight.
7. Verify that the drill press is set to the correct speed for the turning operation. The typical spindle speeds for turning are listed below:
 - For roughing, start with a spindle speed of 750 RPM.
 - For shaping, start with a spindle speed of 1500 RPM.
 - For finishing, start with a spindle speed of 3000 RPM.
8. Turn the workpiece by hand to ensure rotation is unobstructed, and start the drill press.

CAUTION

Feeding the tip of the chisel into the workpiece at too sharp of an angle will cause the chisel to dig into the workpiece, which may eject the chisel or workpiece and cause severe injury. Always keep the chisel perpendicular to the workpiece so it drags across the workpiece rather than digging in.

9. Tightly hold the chisel, and position the chisel against the tool rest (see **Figure 6**).

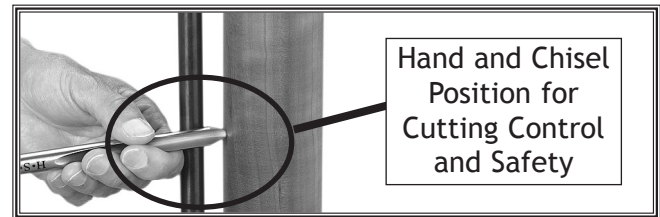

Figure 6. Hand and chisel positioning.

10. Hold the chisel tightly so it is perpendicular to the workpiece, and slowly feed it into the workpiece.
11. Keeping the chisel within the safest working area shown in **Figure 7**, carefully slide the chisel up and down along the tool rest to shape the wood. Keep in mind that the closer the chisel moves toward the end of the tool rest the easier it is to slide the chisel off of the end. Working closer to the end of the rest can also increase tool chatter. As workpiece diameter decreases, re-adjust the tool rest as required to keep the gap at a safe minimum.

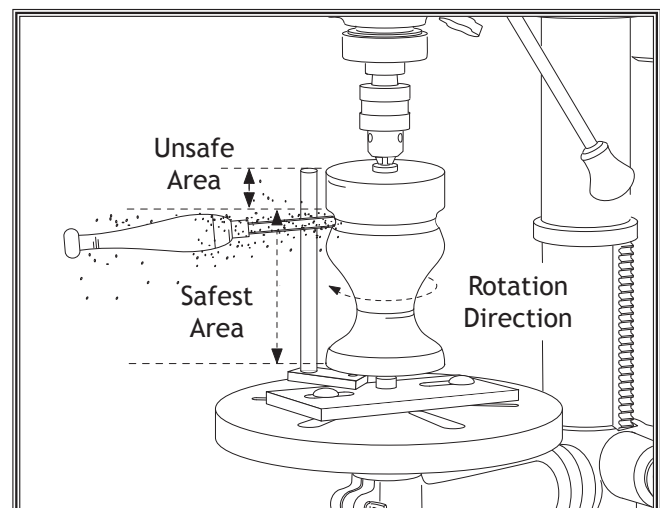

Figure 7. Typical turning operation.

Free Manuals Download Website

<http://myh66.com>

<http://usermanuals.us>

<http://www.somanuals.com>

<http://www.4manuals.cc>

<http://www.manual-lib.com>

<http://www.404manual.com>

<http://www.luxmanual.com>

<http://aubethermostatmanual.com>

Golf course search by state

<http://golfingnear.com>

Email search by domain

<http://emailbydomain.com>

Auto manuals search

<http://auto.somanuals.com>

TV manuals search

<http://tv.somanuals.com>