

MODEL W1780

1¹/₄" BRAD NAILER



OWNER'S MANUAL

Phone: (360) 734-3482 · Online Technical Support: tech-support@shopfox.biz

COPYRIGHT © JUNE, 2007 BY WOODSTOCK INTERNATIONAL, INC., REVISED DECEMBER, 2007 (JM)
WARNING: NO PORTION OF THIS MANUAL MAY BE REPRODUCED IN ANY SHAPE OR FORM WITHOUT
THE WRITTEN APPROVAL OF WOODSTOCK INTERNATIONAL, INC.

#9550TS Printed in China

WARNING

This manual provides critical safety instructions on the proper setup, operation, maintenance, and service of this machine/equipment.

Failure to read, understand, and follow the instructions given in this manual may result in serious personal injury, including amputation, electrocution, or death.

The owner of this machine/equipment is solely responsible for its safe use. This responsibility includes, but is not limited to, proper installation in a safe environment, personnel training and usage authorization, proper inspection and maintenance, manual availability and comprehension, application of safety devices, blade/cutter integrity, and the usage of personal protective equipment.

The manufacturer will not be held liable for injury or property damage from negligence, improper training, machine modifications, or misuse.

WARNING

Some dust created by power sanding, sawing, grinding, drilling, and other construction activities contains chemicals known to the State of California to cause cancer, birth defects, or other reproduction harm. Some examples of these chemicals are:

- Lead from lead-based paints.
- Crystalline silica from bricks, cement, and other masonry products.
- Arsenic and chromium from chemically-treated lumber.

Your risk from these exposures varies, depending on how often you do this type of work. To reduce your exposure to these chemicals: Work in a well ventilated area, and work with approved safety equipment, such as those dust masks that are specially designed to filter out microscopic particles.

SAFETY

WARNING

For Your Own Safety Read Instruction Manual Before Operating This Equipment

The purpose of safety symbols is to attract your attention to possible hazardous conditions. This manual uses a series of symbols and signal words which are intended to convey the level of importance of the safety messages. The progression of symbols is described below. Remember that safety messages by themselves do not eliminate danger and are not a substitute for proper accident prevention measures.

DANGER

Indicates an imminently hazardous situation which, if not avoided, **WILL** result in death or serious injury.

WARNING

Indicates a potentially hazardous situation which, if not avoided, **COULD** result in death or serious injury.

CAUTION

Indicates a potentially hazardous situation which, if not avoided, **MAY** result in minor or moderate injury. It may also be used to alert against unsafe practices.

NOTICE

This symbol is used to alert the user to useful information about proper operation of the equipment.

WARNING

Safety Instructions for Pneumatic Tools

1. **KEEP ALL SAFETY DEVICES IN PLACE** and in working order.
2. **REMOVE ADJUSTING KEYS AND WRENCHES.** Form habit of checking to see that keys and adjusting wrenches are removed from tool before operation.
3. **KEEP WORK AREA CLEAN.** Cluttered areas and benches invite accidents.
4. **DO NOT USE IN DANGEROUS ENVIRONMENT.** Do not use pneumatic tools in damp or wet locations, or where any flammable or noxious fumes may exist. Keep work area well lighted.
5. **KEEP CHILDREN AND VISITORS AWAY.** All children and visitors should be kept at a safe distance from work area.
6. **MAKE WORKSHOP CHILD PROOF** by locking your shop and shutting off air valves.
7. **DO NOT FORCE TOOL.** It will do the job better and safer at the rate for which it was designed.
8. **USE THE RIGHT TOOL.** Do not force tool or attachment to do a job for which it was not designed.
9. **DO NOT USE UNDER THE INFLUENCE OF DRUGS OR ALCOHOL.**

WARNING

Safety Instructions for Pneumatic Tools

10. **USE PROPER AIR HOSE** for the tool. Make sure your air hose is in good condition and is long enough to reach your work without stretching.
11. **WEAR PROPER APPAREL.** Do not wear loose clothing, gloves, neckties, rings, bracelets, or other jewelry which may get caught in moving parts. Non-slip footwear is recommended. Wear a protective hair covering to contain long hair.
12. **ALWAYS USE SAFETY GLASSES.** Also use a face or dust mask if cutting operation is dusty. Everyday eyeglasses only have impact resistant lenses, they are NOT safety glasses.
13. **WEAR APPROVED HEARING PROTECTION.** Air escaping from pneumatic tools can exceed safe exposure limits and may cause hearing damage with prolonged exposure.
14. **SECURE WORK.** Use clamps or a vise to hold work when practical. It is safer than using your hand and frees both hands to operate tool.
15. **MAINTAIN TOOLS WITH CARE.** Keep tools lubricated and clean for best and safest performance. Follow instructions for lubricating and changing accessories.
16. **REDUCE THE RISK OF UNINTENTIONAL FIRING.** Do not carry tool with hand on trigger and always disconnect from air when not in use.
17. **DISCONNECT TOOLS** before servicing, changing accessories, or moving to another location.
18. **DO NOT OVERREACH.** Keep proper footing/balance at all times.
19. **USE THE RECOMMENDED ACCESSORIES.** Consult owner's manual for recommended accessories. The use of improper accessories may cause risk of injury.
20. **CHECK FOR DAMAGED PARTS BEFORE USING.** Check for binding and alignment of parts, broken parts, part mounting, loose bolts, and any other conditions that may affect machine operation. Repair or replace damaged parts.
21. **NEVER LEAVE UNATTENDED TOOL CONNECTED TO AIR.** Disconnect the air hose and do not leave tool until it is relieved of any built up pressure.
22. **NEVER ALLOW UNTRAINED USERS TO USE THIS TOOL WHILE UNSUPERVISED.**
23. **IF YOU ARE UNSURE OF THE INTENDED OPERATION, STOP USING TOOL.** Seek formal training or research books or magazines that specialize in pneumatic tools.
24. **BE AWARE OF HOSE LOCATION WHEN USING PNEUMATIC TOOLS.** Hoses can easily become a tripping hazard when laid across the floor or spread out in a disorganized fashion.

WARNING

Additional Safety for Nailers/Staplers

1. **HAND INJURIES:** Do not place your hands near the nail point of entry. A nail can deflect and tear through the surface of the workpiece, puncturing your hand or fingers.
2. **COMBUSTIBLE GASES:** Never connect the nailer to pressurized oxygen or other combustible gases as a power source. Only use filtered, lubricated, and regulated compressed air.
3. **SAFE HANDLING:** Never point the nailer at others! Do not keep the trigger pulled when loading fasteners, carrying, or holding tool. Carry the nailer only by the handle, never by any other part. Do not carry the nailer by the air hose. Disconnect the nailer from the air hose when going up and down ladders.
4. **CLEANING:** Never use gasoline or other flammable liquids to clean the nailer; vapors in the nailer will ignite by a spark and cause it to explode.
5. **HOSE USAGE:** Make sure your air hose is designed for the tool in use, is in good condition, and is long enough to reach your work without stretching. However, an overly long air hose in the work area may be a tripping hazard.
6. **OPERATING QUESTIONS:** If you are not sure about the intended operation, stop using the nailer. Seek formal training.
7. **MAINTENANCE:** Always disconnect air from the nailer when servicing or installing nails. During maintenance, a nailer connected to air may fire accidentally, causing serious personal injury.
8. **COMPRESSED AIR RATING:** Do not connect the nailer to compressed air that exceeds 120 PSI.
9. **CHECK VALVE:** Do not use a check valve or any other fitting that allows air to remain in the tool.
10. **MODIFICATIONS:** DO NOT modify this tool or bypass the safety nose mechanism.

WARNING

Never point this nailer at yourself or another person! Always pay attention to the direction this nailer is pointed. Use this tool with respect and caution to lessen the possibility of operator or bystander injury. Ignoring this warning may result in serious personal injury.

CAUTION

Nailer/stapler accidents routinely happen while moving the gun to another location, such as up ladders, to another room, or even another job site. Always disconnect the gun immediately after use and never transport the gun while connected to the air—even if the air compressor is disconnected from its power source!

INTRODUCTION

Woodstock Technical Support

This Model W1780 1 1/4" Brad Nailer has been specially designed to provide many years of trouble-free service. Close attention to detail, ruggedly built parts and a rigid quality control program assure safe and reliable operation.

Woodstock International, Inc. is committed to customer satisfaction. Our intent with this manual is to include the basic information for safety, setup, operation, maintenance, and service of this product.

We stand behind our tools! In the event that questions arise about your machine, please contact Woodstock International Technical Support at (360) 734-3482 or send e-mail to: tech-support@shopfox.biz. Our knowledgeable staff will help you troubleshoot problems and process warranty claims.

If you need the latest edition of this manual, you can download it from <http://www.shopfox.biz>.

If you have comments about this manual, please contact us at:

Woodstock International, Inc.
Attn: Technical Documentation
Manager
P.O. Box 2309
Bellingham, WA 98227
Email: manuals@woodstockint.com

Tool Data

Nail Size	18 Gauge
Nail Length.....	3/8"-1 1/4"
Magazine Capacity	100 Nails
Air Inlet.....	1/4" NPT
Weight	3 1/4 lbs.
Operating Pressure	60-100 PSI

WARNING



Read the manual before operation. Become familiar with this nailer, its safety instructions, and its operation before beginning any work. Serious personal injury may result if safety or operational information is not understood or followed.

CAUTION

No list of safety guidelines can be complete. Every shop environment is different. Always consider safety first, as it applies to your individual working conditions. Use this and other tools with caution and respect. Failure to do so could result in serious personal injury, damage to equipment or poor work results.

Compressed Air System

The Model W1780 is designed to be operated at 60-100 PSI using clean, dry, regulated, compressed air. **Do not exceed the 120 PSI maximum pressure for your model.**

Before using your new nailer, regulate the air pressure to the minimum PSI for your model.

An in-line filter/lubricator/regulator unit can be installed as depicted in **Figure 1**.

This filter/lubricator/regulator unit will protect your tool from damaging water build-up, allow you to adjust and maintain regulated air pressure, and save you the inconvenience of having to manually lubricate your tool every time you use it.

If you plan on installing a filter/lubricator/regulator unit in your compressed air system, always follow the connection instructions that come with the unit.

⚠ CAUTION

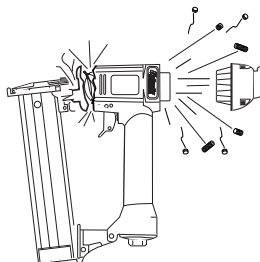

Exceeding the maximum permissible operating pressure may damage the nailer and cause it to malfunction. To protect yourself from personal injury, DO NOT allow the air pressure to exceed the recommended pressure for this nailer!

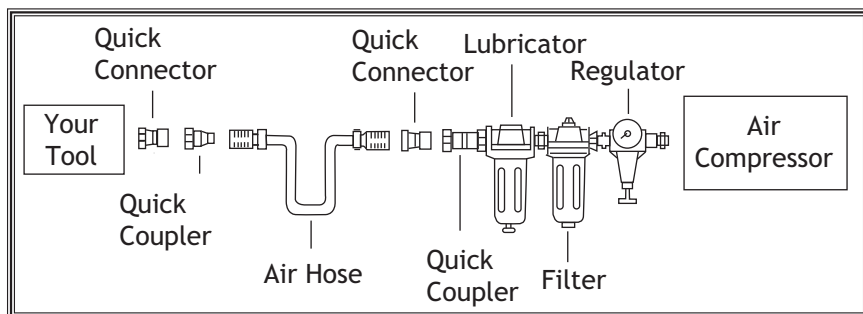

Figure 1. Typical filter/lubricator/regulator installation order.

SETUP

Unpacking

This brad nailer has been carefully packaged for safe transportation. If you notice the machine has been damaged during shipping, please contact your authorized Shop Fox dealer immediately.

Inventory

The following is a description of the main components shipped with the Model W1780. Lay the components out to inventory them.

Note: *If you can't find an item on this list, check the mounting location on the tool or examine the packaging materials carefully. Occasionally we pre-install certain components for safer shipping.*



Model W1780 Inventory	Qty
A. Brad Nailer	1
B. Pneumatic Tool Oil	1
C. Hex Wrench 3mm	1
D. Hex Wrench 4mm	1
E. Carrying Case	1

Safety Nose Mechanism

A safety mechanism on the nose of the nailer protects against accidental firing. When the trigger is pressed, the nailer will not fire until the safety nose mechanism is depressed.

Before you use your nailer for the first time, check the safety nose mechanism to ensure proper function.

To check the safety nose mechanism, do these steps:

1. DISCONNECT NAILER FROM THE AIR SUPPLY!
2. Make sure the magazine is empty and contains no nails.
3. Make sure the trigger and the safety nose mechanism move up and down without sticking.
4. Connect the nailer to the air supply.
5. **Without pressing the trigger**, depress the safety nose mechanism against a scrap piece of wood that is clean and free of any knots, nails, or other foreign objects.
 - If the nailer **does not fire**, then the safety nose mechanism is working correctly.
 - If the nailer **does fire** when you do this, immediately disconnect the nailer from the air supply and call Technical Support.

- If the nailer fires when the trigger is pulled, without the safety nose mechanism being depressed, then the nailer is not working properly.
- If you find that the safety nose mechanism is not working properly, check the lubrication of its sliding components.

WARNING

DO NOT attempt to modify or bypass the safety nose mechanism to make the nailer/stapler fire without pushing the safety nose down.

WARNING

The safety mechanism is a mechanical device that can fail. Never rely on this mechanism as an excuse to point the nailer at yourself or any bystanders. Serious injury may occur.

WARNING

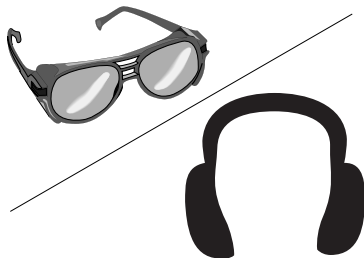

Operating this nailer can propel objects into the air, causing immediate eye damage. To protect yourself, always wear ANSI approved safety glasses or goggles when operating this equipment.

OPERATIONS

Loading

When replacing nails in your Model W1780, follow these guidelines:

Gauge: 18
 Length: 3/8"-1 1/4"
 Capacity: 100

To load your nailer, do these steps:

1. DISCONNECT NAILER FROM THE AIR SUPPLY!
2. Grip the nailer firmly, and pull the magazine pusher back until the catch lever engages, as shown in **Figure 2**.

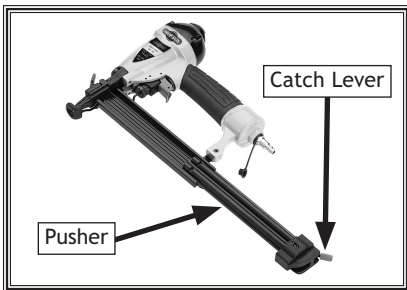

Figure 2. Sliding magazine pusher back and engaging catch lever.

3. Insert a strip of nails, pointed-end down, into the magazine, as shown in **Figure 3**.

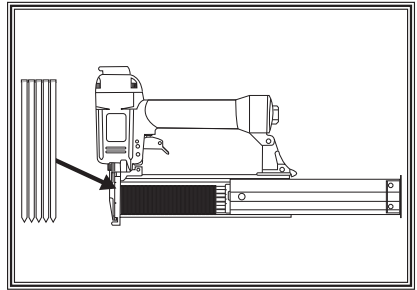

Figure 3. Loading nails into magazine.

4. Slide the nails all the way down to the nose of the nailer.
5. Release the magazine pusher by pulling back on the pusher and pushing in on the catch lever.

Operating

If you have not read the safety instructions in this manual, do not operate the nailer.

Before you operate your nailer, place five to six drops of the included oil into the quick connect fitting where the nailer connects to the air supply.

To operate your nailer, do these steps:

1. Connect the air supply to the quick connect fitting.
2. To test for proper nail penetration, hold the nailer perpendicular to the surface of a piece of clean scrap wood that is thick enough for the length of nails you have loaded.

3. Depress the safety nose mechanism against your workpiece.
4. Before pulling the trigger, make sure your free hand and other body parts are positioned out of the way of a potential path of a nail in case of deflection.

Deflection is caused when grain irregularities, knots or foreign objects inside the wood cause the nail to change its path, resulting in the nail puncturing the surface of the workpiece, as shown in **Figure 4**.

Besides damaging your workpiece, deflection can cause injury if your free hand is securing the workpiece in the location that the nail deflects.

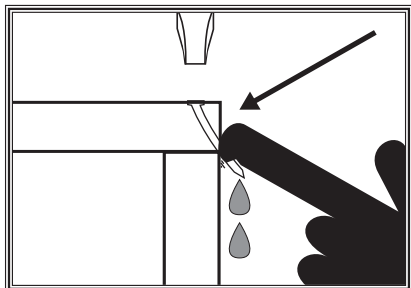

Figure 4. Example of nail deflection.

5. Pull the trigger.
 - If the nail drove into the wood far enough, continue with your intended operations.
 - If the nail either went too far or not far enough, then go to the **Adjusting Depth** section on this page.

Adjusting Depth

A depth adjustment knob is attached to the nose for setting the nail depth.

To adjust the depth, do these steps:

1. DISCONNECT NAILER FROM THE AIR SUPPLY!
2. Rotate the adjustment knob (**Figure 5**) clockwise to increase the nail depth, and counterclockwise to decrease the nail depth.

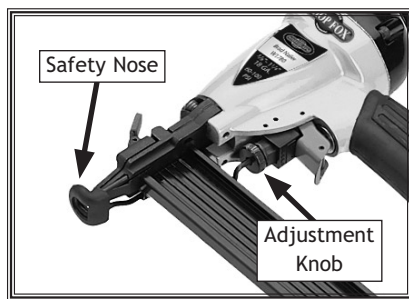

Figure 5. Depth adjustment controls.

3. Connect nailer to the air supply and test the nail depth, and repeat this entire procedure if necessary until the nail depth is satisfactory.

CAUTION

DO NOT place your hands near the nail point of entry. A nail can deflect and tear through the surface of the workpiece, puncturing your hand or fingers.

Clearing Jammed Nails

A jammed nail must be cleared before using the nailer again.

To clear a jammed nail from the discharge area, do these steps:

1. DISCONNECT NAILER FROM THE AIR SUPPLY!
2. Pull back and latch the magazine pusher.
3. Remove the nail stick from the magazine.
4. Open the nailer nose by removing the rubber nose tip, squeezing the nose release mechanism (**Figure 6**), and opening the nose cover.

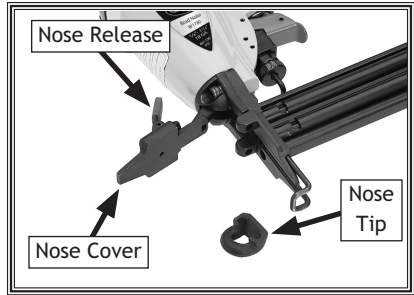

Figure 6. Nose opened to clear a jam.

5. Dislodge the jammed nail with a tool that will fit in the slot on the underside of the nose.
6. Throw the damaged nail away and insert a new nail stick that only contains clean, undamaged nails. **DO NOT** use dirty or damaged nails!
7. Close the nose cover and re-install the nose tip.
8. Release the catch lever and let the pusher slide to the front of the magazine.

Replacing Pistons/ O-Rings

Under heavy use, a piston or piston shaft may wear out. Replacement is quick and easy. Contact your authorized Shop Fox dealer to obtain the Piston Repair Kit (Part Number X1780004).



To replace a piston, do these steps:

1. DISCONNECT NAILER FROM THE AIR SUPPLY!
2. Remove all nails from the magazine cartridge, and clean the exterior of the nailer.
3. Remove the four cap screws on the back of the nailer, near the exhaust port.
4. Remove the cap.
5. The top of the piston should now be visible inside the cylinder, which is housed in the head of the nailer.
6. Open the nose cover as if to clear a jammed nail.
7. Watch the discharge area and push the top of the piston with your finger. You will see the piston shaft slide down the discharge area.
8. Taking care not to scratch or dent the nailer parts, use a wooden dowel or similarly shaped tool to push the piston shaft back inside the nailer until you can grip the piston head and remove it from the cylinder. Clean inspect the parts for cracks, wear, or burrs.
9. Place a new O-ring on the new piston and apply a thin film of the nailer lubricating oil on the O-ring.
10. Insert the new piston in the cylinder. Make sure that the grooves on the piston shaft line up with those on the guide at the bottom of the cylinder. The new piston should easily slide into the cylinder. **DO NOT force the piston into the cylinder!** If the piston is not easily inserted, double-check the alignment of the piston shaft with the grooves on the guide.
11. After the piston is inserted correctly, close the magazine. Replace the rear cap assembly and tighten the four cap screws.
12. For more assistance, or to install a complete O-ring set, refer to the appropriate breakdown diagram in the back of this manual for component locations.

CLEANING & LUBRICATION

Cleaning

Use a good solvent to clean the nose assembly of the nailer. Always be sure that the nailer is dry before using it again.

Do not allow dust, chips, sand, etc. into the air connectors or into the body of the nailer; this may result in leaks and damage to the nailer and the air couplings.



WARNING



Never clean this tool with gasoline or other flammable liquids. Vapors in the tool may ignite, causing the tool to explode. Ignoring this warning may lead to serious personal injury or even death!

Lubricating

Standard pneumatic tool oil has been included with your new Shop Fox nailer to help maintain its useful life. Place two to six drops of oil in the nailer air inlet (as shown in **Figure 7**) before every use, or after 2 hours of continuous use.

Wipe off any excess oil near the nailer exhaust to avoid dust build-up. When the oil that was included with the nailer has been completely used, replace with a quality pneumatic tool oil.

Another option to manual oiling would be to install a lubricator in your air compressor line. If your air compressor line already has a lubricator, then regular lubrication of your nailer will not be necessary. Just make sure there is always oil in the lubricator.

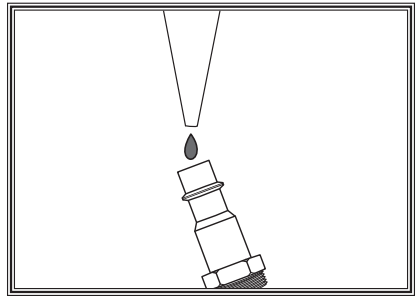
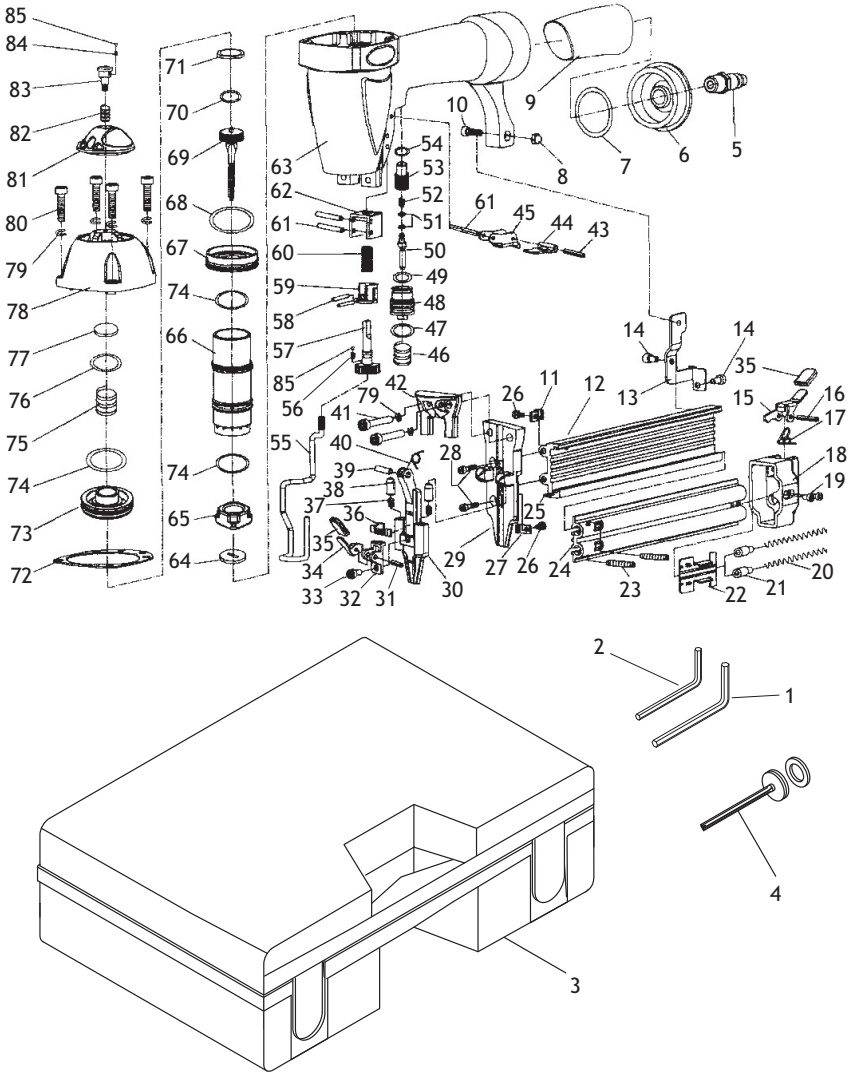

Figure 7. Lubricating nailer via air inlet.

W1780 PARTS BREAKDOWN



W1780 PARTS LIST

REF	PART #	DESCRIPTION
1	XPAW04M	HEX WRENCH 4MM
2	XPAW03M	HEX WRENCH 3MM
3	X1780003	CARRYING CASE
4	X1780004	PISTON REPAIR KIT
5	X1780005	AIR PLUG 1/4 NPT
6	X1780006	END CAP
7	X1780007	O-RING 40 X 2.65
8	X1780008	LOCK NUT M3-.5
9	X1780009	RUBBER HANDGRIP
10	XPSB23M	CAP SCREW M4-.7 X 12
11	X1780011	SAFETY GUARD CLAMP
12	X1780012	MAGAZINE HOUSING
13	X1780013	MAG. CONNECTOR PLATE
14	XPSB18M	CAP SCREW M4-.7 X 8
15	X1780015	CATCH LEVER
16	XPRP42M	ROLL PIN 3 X 20
17	X1780017	TORSION SPRING
18	X1780018	MAGAZINE BRACKET
19	XPSB56M	CAP SCREW M3-.5 X 10
20	X1780020	COMPRESSION SPRING
21	X1780021	SPRING CAP
22	X1780022	MAGAZINE SLIDE PLATE
23	XPSS23M	SET SCREW M4-.7 X 10
24	X1780024	MOVABLE MAGAZINE
25	X1780025	INLAY STRIP
26	XPSB158M	CAP SCREW M3-.5 X 16
27	X1780027	SAFETY GUARD CLAMP
28	XPSB16M	CAP SCREW M4-.7 X 16
29	X1780029	DRIVER GUIDE
30	X1780030	MOVABLE NOSE COVER
31	XPRP61M	ROLL PIN 3 X 12
32	X1780032	NOSE COVER
33	XPSB110M	CAP SCREW M4-.7 X 6
34	X1780034	HANDLE
35	X1780035	HANDLE COVER
36	X1780036	SLIDE BRACKET
37	X1780037	COMPRESSION SPRING
38	X1780038	NOSE COVER LOCKING PIN
39	XPRP18M	ROLL PIN 4 X 12
40	X1780040	TORSION SPRING
41	XPSB15M	CAP SCREW M5-.8 X 20
42	X1780042	GUIDE BRACKET
43	XPRP64M	ROLL PIN 3 X 18

REF	PART #	DESCRIPTION
44	X1780044	SAFETY PLATE
45	X1780045	TRIGGER
46	X1780046	COMPRESSION SPRING
47	X1780047	O-RING 13.2 X 1.9
48	X1780048	SWITCH BRACKET
49	X1780049	O-RING 11.2 X 1.6
50	X1780050	SWITCH SHAFT
51	X1780051	O-RING 1.9 X 1.1
52	X1780052	COMPRESSION SPRING
53	X1780053	TRIGGER VALVE GUIDE
54	X1780054	O-RING 7 X 1.5
55	X1780055	SAFETY GUARD
56	X1780056	COMPRESSION SPRING
57	X1780057	ADJUSTMENT BOLT
58	X1780058	ROLL PIN 1.5 X 8
59	X1780059	SLIDING BRACKET
60	X1780060	COMPRESSION SPRING
61	XPRP55M	ROLL PIN 3 X 27
62	X1780062	BRACKET
63	X1780063	GUN BODY
64	X1780064	PISTON SLOT WASHER
65	X1780065	BUMPER
66	X1780066	CYLINDER
67	X1780067	COLLAR
68	X1780068	O-RING 48.7 X 2.65
69	X1780069	MAIN PISTON
70	X1780070	O-RING 23.5 X 2
71	X1780071	O-RING 30 X 3
72	X1780072	GASKET
73	X1780073	SWITCH PISTON
74	X1780074	O-RING 33.6 X 2
75	X1780075	COMPRESSION SPRING
76	X1780076	O-RING 17 X 2.65
77	X1780077	SEALING WASHER 18MM
78	X1780078	CYLINDER CAP
79	XPLW01M	LOCK WASHER 5MM
80	XPSB15M	CAP SCREW M5-.8 X 20
81	X1780081	EXHAUST PORT
82	X1780082	COMPRESSION SPRING
83	X1780083	SHOULDER BOLT M4-.7 X 16
84	X1780084	ORIENTATION SPRING
85	X1780085	STEEL BALL

Troubleshooting

Symptom	Possible Cause	Possible Solution
Air leaking at trigger valve area.	1. O-rings in trigger valve housing are damaged.	1. O-rings must be replaced & operation of safety nose must be checked.
Air leaking between housing and hose	1. Loose screws in housing. 2. Damaged O-ring. 3. Loose air fitting.	1. Tighten screws. 2. Replace O-ring 3. Tighten air fitting & use teflon tape.
Air leaking between housing and cap.	1. Damaged seal.	1. Replace damaged seals.
Tool skips nails while discharging.	1. Excessive air pressure. 2. Air leaks. 3. Dirt in nose. 4. Dirt or damage prevents nails from moving freely. 5. Inadequate air flow to tool. 6. Worn piston O-ring or lack of lubrication. 7. Damaged trigger valve O-rings. 8. Worn bumper. 9. Cap seal leaking.	1. Reduce air pressure to tool. 2. Tighten screws and fittings. 3. Clean nose. 4. Clean magazine and inspect/repair damage. 5. Check fittings, hose, compressor, and air pressure. 6. Replace O-ring and lubricate. 7. Replace trigger valve O-rings. 8. Replace bumper. 9. Replace cap seal.
Tool runs slowly or has a loss of power.	1. Undersized air hose. 2. Nailer is not lubricated. 3. Broken spring in cap assembly. 4. Exhaust port in cap is blocked.	1. Use a larger hose. 2. Lubricate nailer. 3. Replace spring. 4. Clean or replace damaged internal parts.
Fasteners frequently jam the nailer.	1. Nails are the wrong size. 2. Nails are bent or dirty. 3. Magazine or nose screws are loose. 4. Driver or driver guide are worn or damaged. 5. Nails are wrong angle.	1. Use correct nails. 2. Use undamaged, clean nails. 3. Tighten magazine. 4. Replace worn or damaged parts. 5. Use correct angle nails.
Nailer does not fire.	1. Nailer is not lubricated. 2. Nail is jammed in magazine or discharge area. 3. Piston shaft is damaged. 4. Air pressure too low.	1. Follow lubricating instructions. 2. Clear nailer magazine or discharge area. 3. Replace piston shaft. 4. Check/increase air pressure.
Air blows out of exhaust cap; nailer will not fire.	1. O-ring slipped out of groove or damaged inside nailer.	1. Reinstall/replace suspect O-ring; turn down air pressure.

WARRANTY AND RETURNS

Woodstock International, Inc. warrants its pneumatic equipment to be free of defects from workmanship and materials for a period of 1 year from the date of original purchase. The liability under this warranty shall not exceed the purchase price paid for the products and is limited to credit for, or replacement of the defective part.

We do not warrant or represent that the merchandise complies with the provision of any law or acts, and buyer assumes all risk and liability resulting from the use of the goods, whether using singly or in combination with other products.

This warranty does not apply to defects or damages due directly or indirectly from misuse, abuse, negligence, accidents, repairs or alterations, or lack of maintenance of our products. We shall in no event be liable for death or injuries to persons or property or for incidental, contingent, special or consequential damages arising from the use of our products. This disclaimer applies to both during and after the term of this warranty. Any legal actions brought against Woodstock International, Inc. shall be tried in the State of Washington, County of Whatcom.

Woodstock International, Inc. reserves the right to implement any changes in specifications or discontinue any products without notice.

Warranty Registration

Name _____

Street _____

City _____ State _____ Zip _____

Phone # _____ Email _____ Invoice # _____

Model # _____ Serial # _____ Dealer Name _____ Purchase Date _____

The following information is given on a voluntary basis. It will be used for marketing purposes to help us develop better products and services. Of course, all information is strictly confidential.

1. How did you learn about us?

Advertisement Friend Local Store
 Mail Order Catalog Website Other:

2. How long have you been a woodworker/metalworker?

0-2 Years 2-8 Years 8-20 Years 20+ Years

3. How many of your machines or tools are Shop Fox?

0-2 3-5 6-9 10+

4. Do you think your machine represents a good value? Yes No

5. Would you recommend Shop Fox products to a friend? Yes No

6. What is your age group?

20-29 30-39 40-49
 50-59 60-69 70+

7. What is your annual household income?

\$20,000-\$29,000 \$30,000-\$39,000 \$40,000-\$49,000
 \$50,000-\$59,000 \$60,000-\$69,000 \$70,000+

8. Which of the following magazines do you subscribe to?

<input type="checkbox"/> Cabinet Maker	<input type="checkbox"/> Popular Mechanics	<input type="checkbox"/> Today's Homeowner
<input type="checkbox"/> Family Handyman	<input type="checkbox"/> Popular Science	<input type="checkbox"/> Wood
<input type="checkbox"/> Hand Loader	<input type="checkbox"/> Popular Woodworking	<input type="checkbox"/> Wooden Boat
<input type="checkbox"/> Handy	<input type="checkbox"/> Practical Homeowner	<input type="checkbox"/> Woodshop News
<input type="checkbox"/> Home Shop Machinist	<input type="checkbox"/> Precision Shooter	<input type="checkbox"/> Woodsmith
<input type="checkbox"/> Journal of Light Cont.	<input type="checkbox"/> Projects in Metal	<input type="checkbox"/> Woodwork
<input type="checkbox"/> Live Steam	<input type="checkbox"/> RC Modeler	<input type="checkbox"/> Woodworker West
<input type="checkbox"/> Model Airplane News	<input type="checkbox"/> Rifle	<input type="checkbox"/> Woodworker's Journal
<input type="checkbox"/> Modeltec	<input type="checkbox"/> Shop Notes	<input type="checkbox"/> Other:
<input type="checkbox"/> Old House Journal	<input type="checkbox"/> Shotgun News	

9. Comments: _____

CUT ALONG DOTTED LINE

FOLD ALONG DOTTED LINE



WOODSTOCK INTERNATIONAL INC.
P.O. BOX 2309
BELLINGHAM, WA 98227-2309



FOLD ALONG DOTTED LINE

TAPE ALONG EDGES--PLEASE DO NOT STAPLE

Free Manuals Download Website

<http://myh66.com>

<http://usermanuals.us>

<http://www.somanuals.com>

<http://www.4manuals.cc>

<http://www.manual-lib.com>

<http://www.404manual.com>

<http://www.luxmanual.com>

<http://aubethermostatmanual.com>

Golf course search by state

<http://golfingnear.com>

Email search by domain

<http://emailbydomain.com>

Auto manuals search

<http://auto.somanuals.com>

TV manuals search

<http://tv.somanuals.com>