

MODEL W1828 12" DISC SANDER



OWNER'S MANUAL

(FOR MODELS MANUFACTURED SINCE 4/11)

Phone: (360) 734-3482 • Online Technical Support: tech-support@shopfox.biz

COPYRIGHT © MAY, 2011 BY WOODSTOCK INTERNATIONAL, INC.
WARNING: NO PORTION OF THIS MANUAL MAY BE REPRODUCED IN ANY SHAPE OR FORM WITHOUT
THE WRITTEN APPROVAL OF WOODSTOCK INTERNATIONAL, INC.

#14118TS Printed in China

WARNING!

This manual provides critical safety instructions on the proper setup, operation, maintenance, and service of this machine/tool. Save this document, refer to it often, and use it to instruct other operators.

Failure to read, understand and follow the instructions in this manual may result in fire or serious personal injury—including amputation, electrocution, or death.

The owner of this machine/tool is solely responsible for its safe use. This responsibility includes but is not limited to proper installation in a safe environment, personnel training and usage authorization, proper inspection and maintenance, manual availability and comprehension, application of safety devices, cutting/sanding/grinding tool integrity, and the usage of personal protective equipment.

The manufacturer will not be held liable for injury or property damage from negligence, improper training, machine modifications or misuse.

WARNING!

Some dust created by power sanding, sawing, grinding, drilling, and other construction activities contains chemicals known to the State of California to cause cancer, birth defects or other reproductive harm. Some examples of these chemicals are:

- Lead from lead-based paints.
- Crystalline silica from bricks, cement and other masonry products.
- Arsenic and chromium from chemically-treated lumber.

Your risk from these exposures varies, depending on how often you do this type of work. To reduce your exposure to these chemicals: Work in a well ventilated area, and work with approved safety equipment, such as those dust masks that are specially designed to filter out microscopic particles.

Contents

INTRODUCTION	2	ACCESSORIES	21
Woodstock Technical Support	2	MAINTENANCE	22
Machine Specifications	3	General	22
Controls and Features	5	Cleaning	22
SAFETY	6	Table & Base	22
Standard Machinery Safety Instructions	6	Lubrication	22
Additional Safety for Disc Sanders	8	SERVICE	23
ELECTRICAL	9	General	23
SETUP	11	Table/Disc Parallelism	23
Needed for Setup	11	Miter Gauge Calibration.....	24
Unpacking	11	Table Tilt Calibration	24
Inventory	11	Troubleshooting.....	25
Machine Placement	12	Electrical Safety Instructions.....	27
Cleaning Machine.....	12	Wiring Diagram	28
Bench Mounting.....	13	PARTS	29
Dust Collection	13	WARRANTY	33
Power Connection.....	14		
Test Run.....	15		
OPERATIONS	16		
General	16		
Basic Controls.....	16		
Disabling ON/OFF Switch	17		
Operation Overview	17		
Choosing Sandpaper	18		
Stock Inspection and Requirements	18		
Attaching Sandpaper.....	19		
Disc Sanding.....	20		

USE THE QUICK GUIDE PAGE LABELS TO SEARCH OUT INFORMATION FAST!





INTRODUCTION

Woodstock Technical Support

This machine has been specially designed to provide many years of trouble-free service. Close attention to detail, ruggedly built parts and a rigid quality control program assure safe and reliable operation.

Woodstock International, Inc. is committed to customer satisfaction. Our intent with this manual is to include the basic information for safety, setup, operation, maintenance, and service of this product.

We stand behind our machines! In the event that questions arise about your machine, please contact Woodstock International Technical Support at (360) 734-3482 or send e-mail to: tech-support@shopfox.biz. Our knowledgeable staff will help you troubleshoot problems and process warranty claims.

If you need the latest edition of this manual, you can download it from <http://www.shopfox.biz>.
If you have comments about this manual, please contact us at:

Woodstock International, Inc.
Attn: Technical Documentation Manager
P.O. Box 2309
Bellingham, WA 98227
Email: manuals@woodstockint.com

MACHINE SPECIFICATIONS



© Woodstock International, Inc. • Phone: (800) 840-8420 • Web: www.shopfox.biz

MODEL W1828 SHOP FOX 12" DISC SANDER

Motors

Main

Type.....	TEFC Capacitor Start
Horsepower.....	1 HP
Voltage.....	110V
Phase.....	Single
Amps.....	10A
Speed.....	1725 RPM
Cycle.....	60 Hz
Number of Speeds.....	1
Power Transfer	Direct Drive
Bearings.....	Sealed and Permanently Lubricated

Main Specifications

Table Info

Table Width.....	4-1/2 in.
Table Length.....	15-3/4 in.
Table Thickness.....	3/4 in.
Table Tilt.....	0 - 45 deg.
Miter Gauge Slot Width.....	5/8 in.
Miter Gauge Slot Height.....	1/4 in.

Spindle Info

Arbor Size.....	15 mm
Total Arbor Length.....	1-1/2 in.

Disc Info

Sanding Disc Diameter.....	12 in.
Sanding Disc Speed.....	1725 RPM

Construction

Base.....	Cast Iron
Table.....	Cast Iron
Frame.....	Cast Iron
Disc.....	Cast Aluminum
Miter Gauge.....	Cast Aluminum
Paint.....	Epoxy

Other

No. Of Dust Ports.....	1
Dust Port Size.....	2 in.



Product Dimensions

Weight..... 68 lbs.
 Width (side-to-side) x Depth (front-to-back) x Height..... 18 x 17-3/8 x 14-1/2 in.
 Footprint (Length x Width)..... 13 x 10 in.

Shipping Dimensions

Type..... Cardboard
 Content..... Machine
 Weight..... 74 lbs.
 Length x Width x Height..... 18 x 18 x 17 in.

Electrical

Power Requirement..... 110V, Single-Phase, 60 Hz
 Full-Load Current Rating..... 7.5A
 Minimum Circuit Size..... 15A
 Switch..... Paddle Switch w/Disabling Key
 Switch Voltage..... 110V
 Cord Length..... 5 ft.
 Cord Gauge..... 16 Gauge
 Plug Included..... Yes
 Included Plug Type..... NEMA 5-15

Other

Country Of Origin China
 Warranty 2 Year
 Assembly Time 5 Minutes

Features

- Locking Miter Bar
- Built-In Dust Port
- Non-Slip Rubber Feet

Controls and Features

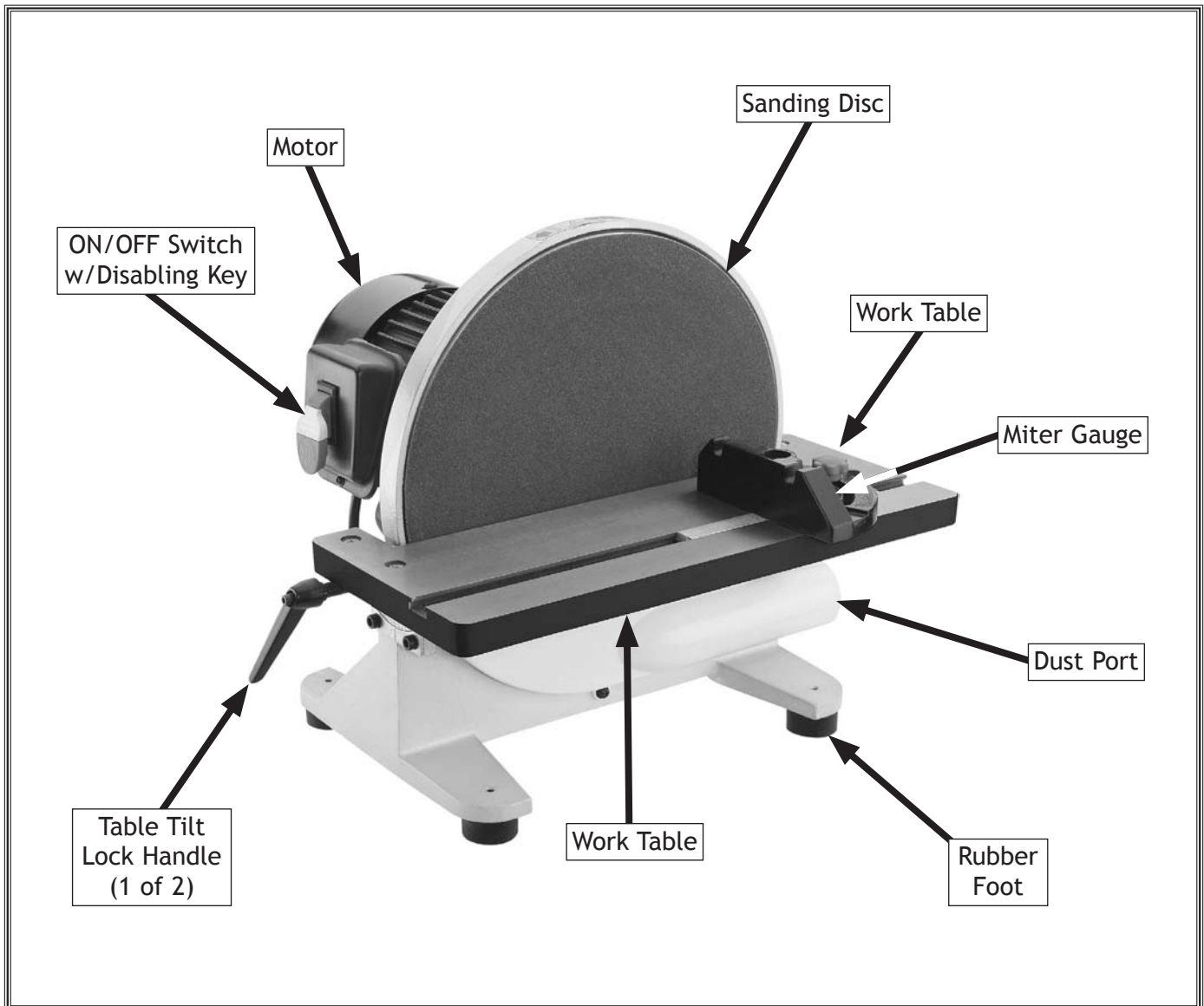
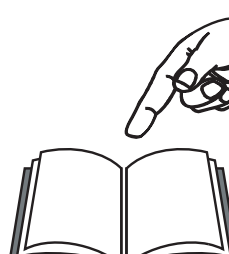

Figure 1. Model W1828 controls and features.

	<p>⚠ WARNING READ and understand this entire manual before using this machine. Serious personal injury may occur if safety and operational information is not understood and followed. DO NOT risk your safety by not reading!</p>
---	--

SAFETY

For Your Own Safety, Read Manual Before Operating Machine

The purpose of safety symbols is to attract your attention to possible hazardous conditions. This manual uses a series of symbols and signal words intended to convey the level of importance of the safety messages. The progression of symbols is described below. Remember that safety messages by themselves do not eliminate danger and are not a substitute for proper accident prevention measures—this responsibility is ultimately up to the operator!



Indicates an imminently hazardous situation which, if not avoided, **WILL** result in death or serious injury.



Indicates a potentially hazardous situation which, if not avoided, **COULD** result in death or serious injury.



Indicates a potentially hazardous situation which, if not avoided, **MAY** result in minor or moderate injury.

NOTICE

This symbol is used to alert the user to useful information about proper operation of the equipment, and/or a situation that may cause damage to the machinery.

Standard Machinery Safety Instructions

OWNER'S MANUAL. Read and understand this owner's manual **BEFORE** using machine. Untrained users can be seriously hurt.

EYE PROTECTION. Always wear ANSI-approved safety glasses or a face shield when operating or observing machinery to reduce the risk of eye injury or blindness from flying particles. Everyday eyeglasses are not approved safety glasses.

HAZARDOUS DUST. Dust created while using machinery may cause cancer, birth defects, or long-term respiratory damage. Be aware of dust hazards associated with workpiece materials, and always wear a NIOSH-approved respirator to reduce your risk.

WEARING PROPER APPAREL. Do not wear clothing, apparel, or jewelry that can become entangled in moving parts. Always tie back or cover long hair. Wear non-slip footwear to avoid accidental slips which could cause a loss of workpiece control.

HEARING PROTECTION. Always wear hearing protection when operating or observing loud machinery. Extended exposure to this noise without hearing protection can cause permanent hearing loss.

MENTAL ALERTNESS. Be mentally alert when running machinery. Never operate under the influence of drugs or alcohol, when tired, or when distracted.

DISCONNECTING POWER SUPPLY. Always disconnect machine from power supply before servicing, adjusting, or changing cutting tools (bits, blades, cutters, etc.). Make sure switch is in **OFF** position before reconnecting to avoid an unexpected or unintentional start.

DANGEROUS ENVIRONMENTS. Do not use machinery in wet or rainy locations, cluttered areas, around flammables, or in poorly-lit areas. Keep work area clean, dry, and well-lit to minimize risk of injury.

APPROVED OPERATION. Untrained operators can be seriously hurt by machinery. Only allow trained or properly supervised people to use machine. When machine is not being used, disconnect power, remove switch keys, or lock-out machine to prevent unauthorized use—especially around children. Make workshop kid proof!

ONLY USE AS INTENDED. Only use machine for its intended purpose. Never modify or alter machine for a purpose not intended by the manufacturer or serious injury may result!

USE RECOMMENDED ACCESSORIES. Consult this owner's manual or the manufacturer for recommended accessories. Using improper accessories will increase the risk of serious injury.

CHILDREN & BYSTANDERS. Keep children and bystanders a safe distance away from work area. Stop using machine if children or bystanders become a distraction.

REMOVE ADJUSTING TOOLS. Never leave adjustment tools, chuck keys, wrenches, etc. in or on machine—especially near moving parts. Verify removal before starting!

SECURING WORKPIECE. When required, use clamps or vises to secure workpiece. A secured workpiece protects hands and frees both of them to operate the machine.

FEED DIRECTION. Unless otherwise noted, feed work against the rotation of blades or cutters. Feeding in the same direction of rotation may pull your hand into the cut.

GUARDS & COVERS. Guards and covers can protect you from accidental contact with moving parts or flying debris. Make sure they are properly installed, undamaged, and working correctly before using machine.

NEVER STAND ON MACHINE. Serious injury or accidental contact with cutting tool may occur if machine is tipped. Machine may be damaged.

STABLE MACHINE. Unexpected movement during operations greatly increases the risk of injury and loss of control. Verify machines are stable/secure and mobile bases (if used) are locked before starting.

FORCING MACHINERY. Do not force machine. It will do the job safer and better at the rate for which it was designed.

AWKWARD POSITIONS. Keep proper footing and balance at all times when operating machine. Do not overreach! Avoid awkward hand positions that make workpiece control difficult or increase the risk of accidental injury.

UNATTENDED OPERATION. Never leave machine running while unattended. Turn machine off and ensure all moving parts completely stop before walking away.

MAINTAIN WITH CARE. Follow all maintenance instructions and lubrication schedules to keep machine in good working condition. An improperly maintained machine may increase the risk of serious injury.

CHECK DAMAGED PARTS. Regularly inspect machine for damaged parts, loose bolts, mis-adjusted or mis-aligned parts, binding, or any other conditions that may affect safe operation. Always repair or replace damaged parts, wires, cords, or plugs before operating machine.

MAINTAIN POWER CORDS. When disconnecting cord-connected machines from power, grab and pull the plug—NOT the cord. Pulling the cord may damage the wires inside. Do not handle the cord/plug with wet hands. Avoid cord damage by keeping it away from heated surfaces, high traffic areas, harsh chemicals, and wet or damp locations.

EXPERIENCING DIFFICULTIES. If at any time you are experiencing difficulties performing the intended operation, stop using the machine! Contact our Technical Support for help at (360) 734-3482.

Additional Safety for Disc Sanders

SAFETY

DISC DIRECTION. Only sand on the downward-moving left side of the sanding disc. Sanding on the upward-moving right side of the sanding disc forces the operator to rely only on hands (rather than the table) for support, which increases the risk of workpiece "kick-out" and impact/abrasion injuries.

AVOIDING ENTANGLEMENT. Becoming entangled in the moving parts of this machine can cause pinching and crushing injuries. To avoid these hazards, DO NOT wear loose clothing, gloves, or jewelry, and tie back long hair. Keep all guards in place and secure.

HAND PLACEMENT. Rotating sandpaper can remove a large amount of flesh in a few seconds. Always keep hands away from the sandpaper during operation. Never intentionally touch moving sandpaper.

MINIMUM STOCK DIMENSION. Small workpieces can be aggressively pulled from your hands and present injury hazards. Always use a jig or other holding device when sanding small workpieces, and keep your hands and fingers at least 2" away from the sanding surface.

WORKPIECE SUPPORT. Workpiece kickback can occur with violent force if the workpiece is not properly supported during operation. Always sand with the workpiece firmly against the table or another support device.

SANDING DUST. Sanding creates large amounts of dust and flying chips that can lead to eye injury or respiratory illness. Reduce the risk of these hazards by always wearing approved eye and respiratory protection when using the sander.

WORKPIECE INSPECTION. Nails, staples, knots, or other imperfections in the workpiece can be dislodged and thrown from the sander at a high rate of speed into the operator or bystanders, or cause damage to sandpaper or sander. Never attempt to sand stock that has embedded foreign objects or questionable imperfections.

FEEDING WORKPIECE. Forcefully jamming the workpiece into the sanding surface could cause the workpiece to be aggressively grabbed and pull your hands into the sanding surface. Always firmly grasp the workpiece in both hands and ease it into the sandpaper slowly using light pressure.

SANDPAPER CONDITION. Sandpaper that is worn or damaged not only produces poor sanding results, but could fly apart, aggressively grab the workpiece, and throw debris at the operator. Always inspect the sandpaper before operation and replace it if worn or damaged.

IN-RUNNING NIP POINTS. The gap between the moving sandpaper and the fixed table/support creates a pinch point for fingers or workpieces; the larger this gap is, the greater the risk of fingers or workpieces getting caught in it. Minimize this risk by adjusting the table no more than 1/16" away from the sandpaper.

WORKPIECE INTEGRITY. Only sand solid workpieces that can withstand the forces required for power sanding. Make sure the shape of the workpiece can be properly supported on the table; avoid sanding workpieces without flat bottom surfaces unless some type of jig is used to maintain support and control when the sanding force is applied.

CAUTION

USE this and other machinery with caution and respect. Always consider safety first, as it applies to your individual working conditions. No list of safety guidelines can be complete—every shop environment is different. Failure to follow guidelines could result in serious personal injury, damage to equipment or poor work results.

ELECTRICAL

Availability

Before installing the machine, consider the availability and proximity of the required power supply circuit. If an existing circuit does not meet the requirements for this machine, a new circuit must be installed. To minimize the risk of electrocution, fire, or equipment damage, installation work and electrical wiring must be done by a qualified electrician in accordance with all applicable codes and standards.

Full-Load Current Rating

The full-load current rating is the amperage a machine draws at 100% of the rated output power. On machines with multiple motors, this is the amperage drawn by the largest motor or sum of all motors and electrical devices that might operate at one time during normal operations.

Full-Load Current Rating at 110V 7.5 Amps

The full-load current is not the maximum amount of amps that the machine will draw. If the machine is overloaded, it will draw additional amps beyond the full-load rating.

If the machine is overloaded for a sufficient length of time, damage, overheating, or fire may result—especially if connected to an undersized circuit. To reduce the risk of these hazards, avoid overloading the machine during operation and make sure it is connected to a power supply circuit that meets the requirements in the following section.

Circuit Requirements

This machine is prewired to operate on a 110V power supply circuit that has a verified ground and meets the following requirements:

- Nominal Voltage 110V/120V
- Cycle.....60 Hz
- Phase Single-Phase
- Minimum Circuit Size 15 Amps

A power supply circuit includes all electrical equipment between the breaker box or fuse panel in the building and the machine. The power supply circuit used for this machine must be sized to safely handle the full-load current drawn from the machine for an extended period of time. (If this machine is connected to a circuit protected by fuses, use a time delay fuse marked D.)

⚠ WARNING

Electrocution, fire, or equipment damage may occur if machine is not correctly grounded and connected to the power supply.

⚠ CAUTION

For your own safety and protection of property, consult a qualified electrician if you are unsure about wiring practices or electrical codes in your area.

Note: *The circuit requirements listed in this manual apply to a dedicated circuit—where only one machine will be running at a time. If this machine will be connected to a shared circuit where multiple machines will be running at the same time, consult a qualified electrician to ensure that the circuit is properly sized for safe operation.*

ELECTRICAL

Grounding & Plug Requirements

This machine **MUST** be grounded. In the event of certain malfunctions or breakdowns, grounding reduces the risk of electric shock by providing a path of least resistance for electric current.

This machine is equipped with a power cord that has an equipment-grounding wire and a grounding plug (similar to the figure on the right). The plug must only be inserted into a matching receptacle (outlet) that is properly installed and grounded in accordance with all local codes and ordinances.

Improper connection of the equipment-grounding wire can result in a risk of electric shock. The wire with green insulation (with or without yellow stripes) is the equipment-grounding wire. If repair or replacement of the power cord or plug is necessary, do not connect the equipment-grounding wire to a live (current carrying) terminal.

Check with a qualified electrician or service personnel if you do not understand these grounding requirements, or if you are in doubt about whether the tool is properly grounded. If you ever notice that a cord or plug is damaged or worn, disconnect it from power, and immediately replace it with a new one.

Extension Cords

We do not recommend using an extension cord with this machine. If you must use an extension cord, only use it if absolutely necessary and only on a temporary basis.

Extension cords cause voltage drop, which may damage electrical components and shorten motor life. Voltage drop increases as the extension cord size gets longer and the gauge size gets smaller (higher gauge numbers indicate smaller sizes).

Any extension cord used with this machine must contain a ground wire, match the required plug and receptacle, and meet the following requirements:

Minimum Gauge Size 14 AWG

Maximum Length (Shorter is Better)..... 50 ft.

ELECTRICAL

⚠ WARNING

Serious injury could occur if you connect the machine to power before completing the setup process. **DO NOT** connect to power until instructed later in this manual.

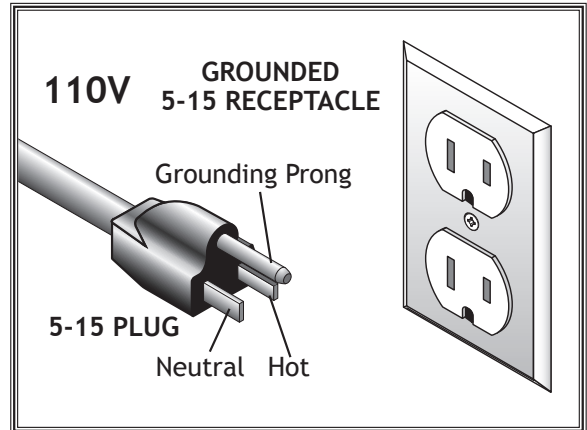

Figure 2. Typical 5-15 plug and receptacle.

⚠ WARNING

DO NOT modify the provided plug or use an adapter if the plug will not fit your receptacle. Instead, have a qualified electrician install the proper receptacle on a power supply circuit that is grounded and meets the requirements for this machine.

SETUP

Needed for Setup

The following are needed to complete the setup process, but are not included with your machine.

Description	Qty
• Safety Glasses.....	1
• Cleaner/Degreaser	As Needed
• Disposable Shop Rags	As Needed
• Dust Collection System	1
• Dust Hose 2"	1
• Dust Hose Clamp 2"	1
• Adapter 4" x 2" (Optional)	1
• Dust Hose 4" (Optional).....	1
• Dust Hose Clamp 4" (Optional)	1
• Mounting Hardware	As Needed

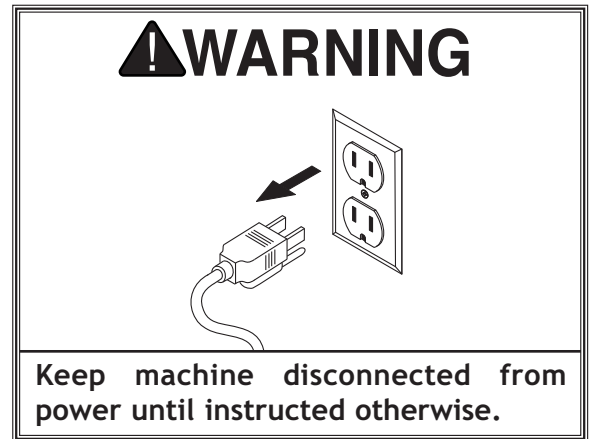

Unpacking

This machine has been carefully packaged for safe transportation. If you notice the machine has been damaged during shipping, please contact your authorized Shop Fox dealer immediately.

Inventory

The following is a description of the main components shipped with the Model W1828. Lay the components out to inventory them.

Note: *If you can't find an item on this list, check the mounting location on the machine or examine the packaging materials carefully. Occasionally we pre-install certain components for safer shipping.*

Box Inventory (Figure 3)	Qty
A. Disc Sander Assembly	1
B. Sandpaper Disc 12" 80 Grit.....	1
C. Miter Gauge Assembly	1

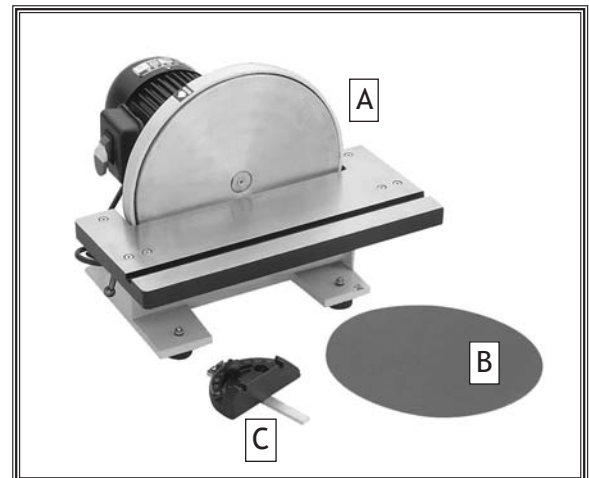

Figure 3. Shipping inventory.

SETUP

Machine Placement

- **Workbench Load:** This machine distributes a heavy load in a small footprint. Some workbenches may require additional bracing to support both machine and workpiece.
- **Working Clearances:** Consider existing and anticipated needs, size of material to be processed through the machine, and space for auxiliary stands, work tables or other machinery when establishing a location for your sander (see Figure 4).
- **Lighting:** Lighting should be bright enough to eliminate shadow and prevent eye strain.

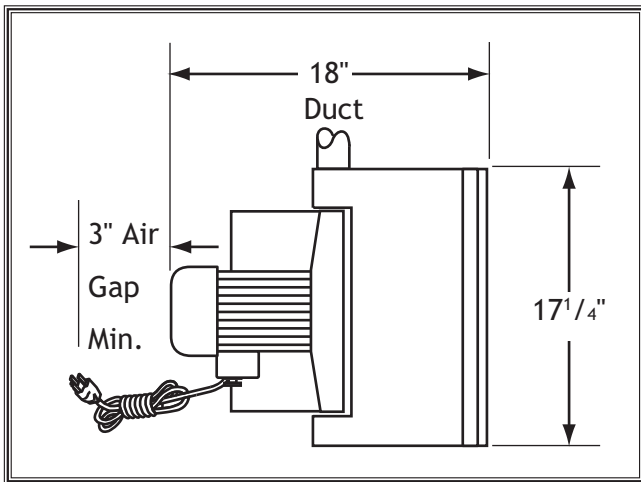



Figure 4. Working clearances.



SETUP

Cleaning Machine

The table and other unpainted parts of your disc sander are coated with a waxy grease that protects them from corrosion during shipment. Clean this grease off with a solvent cleaner or citrus-based degreaser. DO NOT use chlorine-based solvents such as brake parts cleaner or acetone—if you happen to splash some onto a painted surface, you will ruin the finish.

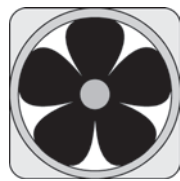

! WARNING
NEVER clean with gasoline or other petroleum-based solvents. Most have low flash points, which make them extremely flammable. A risk of explosion and burning exists if these products are used. Serious personal injury may occur if this warning is ignored!

! CAUTION
ALWAYS work in well-ventilated areas far from possible ignition sources when using solvents to clean machinery. Many solvents are toxic when inhaled or ingested. Use care when disposing of waste rags and towels to be sure they **DO NOT** create fire or environmental hazards.



! CAUTION
MAKE your shop “child safe.” Ensure that your workplace is inaccessible to children by closing and locking all entrances when you are away. **NEVER** allow untrained visitors in your shop when assembling, adjusting or operating equipment.

Bench Mounting

We strongly recommend that you mount your sander to a workbench to prevent it from moving during operation. Before doing so, remove the included feet. An unexpected movement could result in an injury or property damage.

When you have chosen the location to mount the sander, the strongest option is a "Through Mount" where holes are drilled all the way through the workbench, and hex bolts, washers, and hex nuts are used to secure the machine (see Figure 5).

Another option for mounting is a "Direct Mount" where the machine is simply secured to the workbench with a lag screw (see Figure 6).

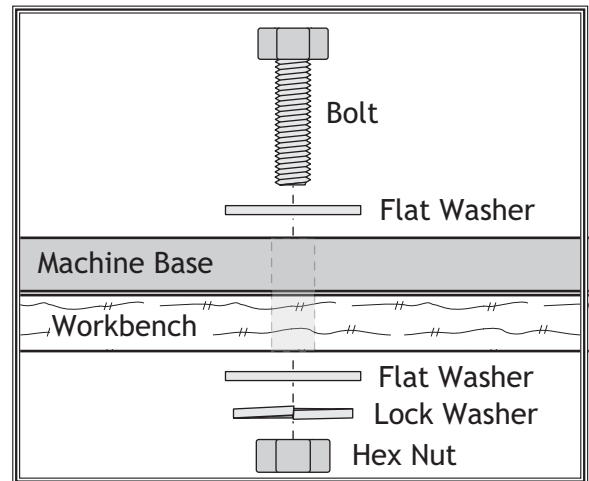

Figure 5. Example of a through mount.

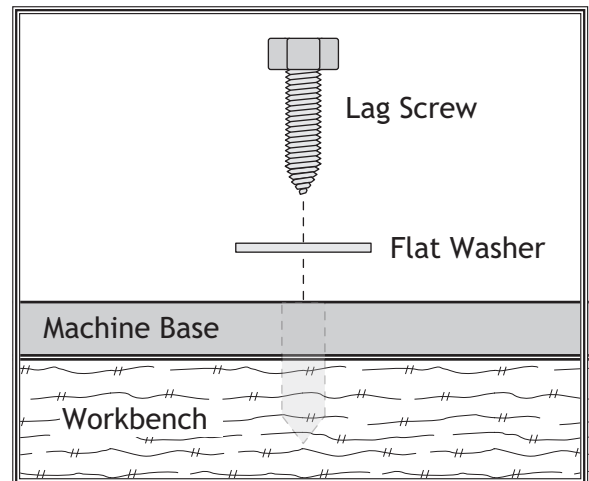

Figure 6. Example of a direct mount.

Dust Collection

Recommended CFM at Dust Port:98 CFM

Do not confuse this CFM recommendation with the rating of the dust collector. To determine the CFM at the dust port, you must take into account many variables, including the CFM rating of the dust collector, the length of hose between the dust collector and the machine, the amount of branches or Y's, and the amount of other open lines throughout the system. Explaining this calculation is beyond the scope of this manual. If you are unsure of your system, consult an expert or purchase a good dust collection "how-to" book.

CAUTION

DO NOT operate this machine without an adequate dust collection system. This machine creates substantial amounts of wood dust while operating. Failure to use a dust collection system can result in short and long-term respiratory illness.

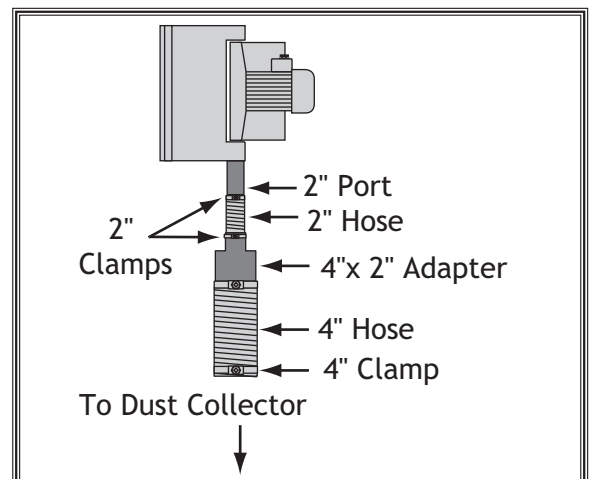

Figure 7. Typical dust collection setup for the Model W1828.

SETUP

Power Connection

After you have completed all previous setup instructions and circuit requirements, the machine is ready to be connected to the power supply.

To avoid unexpected startups or property damage, use the following steps whenever connecting or disconnecting the machine.

Connecting Power

1. Turn the machine power switch **OFF**.
2. Insert the power cord plug into a matching power supply receptacle. The machine is now connected to the power source.

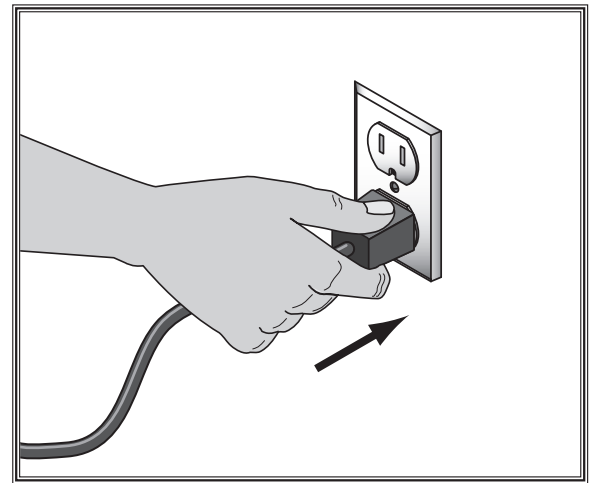

Figure 8. Connecting power.

Disconnecting Power

1. Turn the machine power switch **OFF**.
2. Grasp the molded plug and pull it completely out of the receptacle. Do not pull by the cord as this may damage the wires inside.

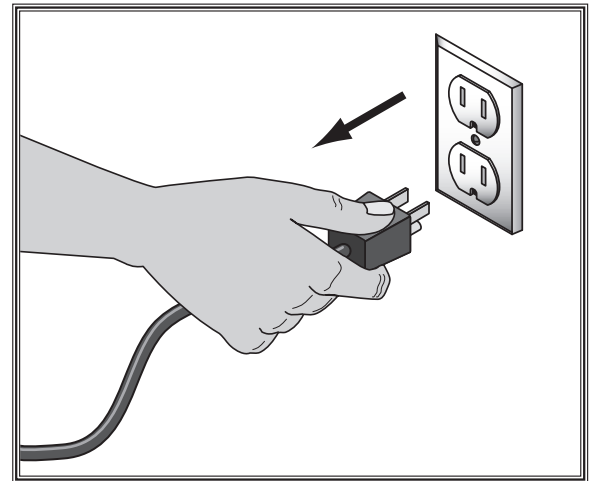

Figure 9. Disconnecting power.

Test Run

Test run your machine to make sure it runs properly and is ready for regular operation.

The test run consists of verifying the following: 1) The motor powers up and runs correctly, and 2) the safety disabling mechanism on the switch works correctly.

If, during the test run, you cannot easily locate the source of an unusual noise or vibration, stop using the machine immediately, then review **Troubleshooting** on **Page 25**. If you still cannot remedy a problem, contact our Tech Support at (360) 734-3482 for assistance.

To test run the machine, do these steps:

1. Make sure you understand the safety instructions at the beginning of the manual, and verify that the machine is set up properly.
2. Ensure all tools and objects used during setup are cleared away from the machine.
3. Verify that the machine is operating correctly by turning the machine **ON**.
 - When operating correctly, the machine runs smoothly with little or no vibration or rubbing noises.
 - Investigate and correct strange or unusual noises or vibrations before operating the machine further. Always disconnect the machine from power when investigating or correcting potential problems.
4. Turn the machine **OFF**.
5. Remove the switch disabling key (**Figure 10**).
6. Try to start the machine with the paddle switch.
 - If the machine does not start, the switch disabling feature is working as designed.
 - If the machine starts, immediately stop the machine. The switch disabling feature is not working correctly. Call Tech Support for help.

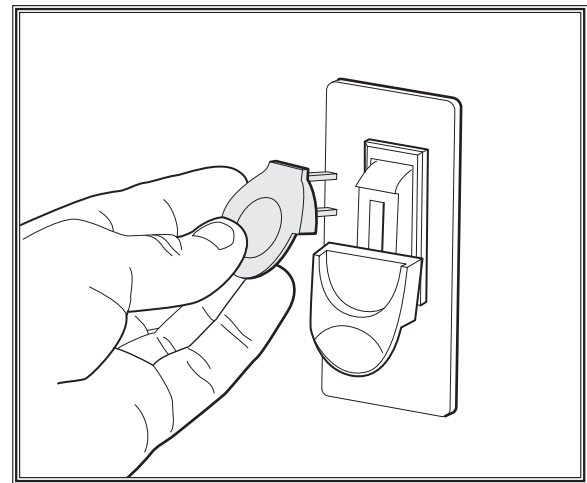
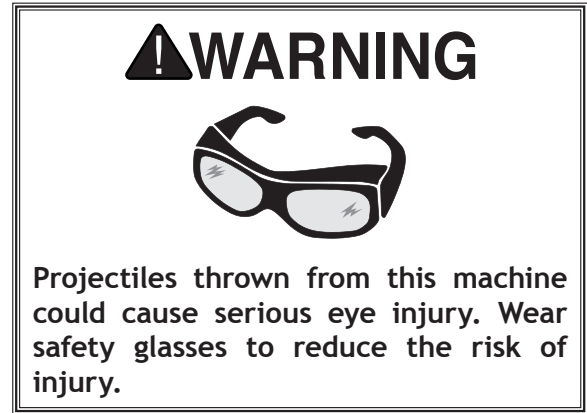

Figure 10. Removing switch key from paddle switch.

SETUP

OPERATIONS

General

This machine will perform many types of operations that are beyond the scope of this manual. Many of these operations can be dangerous or deadly if performed incorrectly.

The instructions in this section are written with the understanding that the operator has the necessary knowledge and skills to operate this machine. **If at any time you are experiencing difficulties performing any operation, stop using the machine!**

If you are an inexperienced operator, we strongly recommend that you read books or trade articles, or seek training from an experienced operator before performing any unfamiliar operations. **Above all, your safety should come first!**

⚠ WARNING



READ and understand this entire instruction manual before using this machine. Serious personal injury may occur if safety and operational information is not understood and followed. DO NOT risk your safety by not reading!

Basic Controls

Refer to **Figure 11** and the following descriptions to become familiar with the basic controls of this machine.

ON/OFF Switch. Turns the motor **ON** when flipped up; turns motor **OFF** when pressed down.

Switch Disabling Key. Disables the switch when the yellow key is removed.

Table Tilt Lock Handles. Locks the table in place. To tilt the table, loosen the handles, tilt the work table to the desired angle, then re-tighten the handles.

Note: *The work table should be set approximately 1/16" away from the sanding disc to prevent fingers or workpieces from getting caught. To adjust the work table relative to the sanding disc, refer to in **Table/Disc Parallelism on Page 23.***

Miter Gauge. Moves workpieces into the sanding disc at a specific angle. To use the miter gauge, slide it into the miter slot, loosen the lock knob, set the angle, then re-tighten the knob.

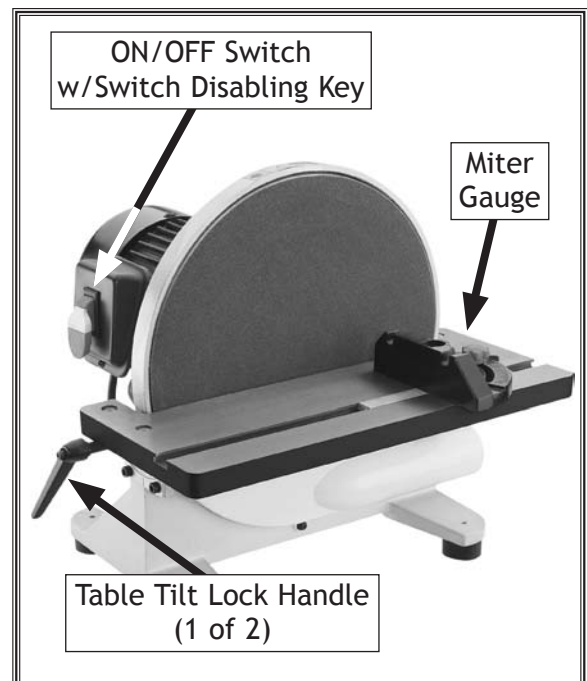

Figure 11. Basic controls.

Disabling ON/OFF Switch

The ON/OFF switch can be disabled by removing the switch disabling key, as shown in **Figure 12**. Disabling the switch in this manner can prevent unauthorized operation of the machine, which is especially important if the machine is not stored inside an access-restricted building.

IMPORTANT: *Disabling the switch by removing the key only restricts its function. It is not a substitute for disconnecting power from the machine when adjusting or servicing.*

Operation Overview

The purpose of this overview is to provide the novice machine operator with a basic understanding of how the machine is used during operation, so the machine controls/components discussed later in this manual are easier to understand.

To complete a sanding operation, the operator does the following:

1. Examines the workpiece to make sure it is suitable for sanding.
2. Adjusts the table tilt if necessary and locks the table in place.
3. If necessary, inserts the miter gauge in the miter slot, adjusts the miter gauge to the required sanding angle, and locks it in place.
4. Wears safety glasses and a respirator.
5. Starts the machine and dust collector.
6. Holds the workpiece firmly and flatly against both the table and miter gauge (if used), pushes the workpiece into or along the sanding disc, and moves it to different locations to wear the sandpaper evenly and prevent it from overheating.
7. Stops the machine.

⚠ WARNING

Children or untrained people can be seriously injured by this machine. This risk increases with unsupervised operation. To help prevent unsupervised operation, disable the switch before leaving the machine unattended! Place the switch disabling key in a well-hidden or secure location.

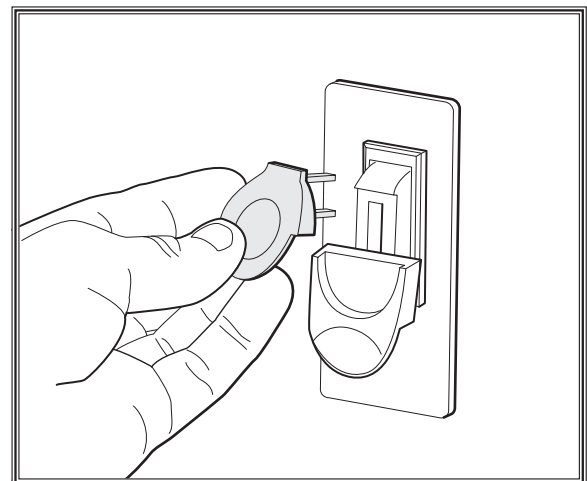

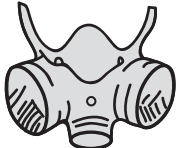

Figure 12. Removing switch key from paddle switch.

⚠ WARNING

Damage to your eyes and lungs could result from using this machine without proper protective gear. Always wear safety glasses and a respirator when operating this machine.

OPERATIONS

Choosing Sandpaper

The Model W1828 uses a 12" adhesive-backed sanding disc.

There are many types of sanding discs to choose from. We recommend aluminum oxide for general workshop environments. Below is a chart that groups abrasives into different classes and shows which grits fall into each class.

Grit	Type
24-36	Very Coarse
40-60	Coarse
80-100	Medium
120-180	Fine
220-360	Very Fine

The general rule of thumb is to sand a workpiece with progressively higher grit numbers, with no one grit increase of more than 50 grits at a time. Avoid skipping grits; the larger the grit increase, the harder it will be to remove the scratches from the previous grit.

Ultimately, the type of wood you use and your stage of finish will determine the best grit types to install on your sander.

Stock Inspection and Requirements

Some workpieces are not safe or may require modification before they are safe to sand. **Before sanding, inspect all workpieces for the following:**

- **Material Type:** Sanding asbestos or workpieces with lead paint can be hazardous to your health. Do not sand workpieces that contain these materials.
- **Foreign Objects:** Nails, staples, dirt, rocks and other foreign objects are often embedded in wood. While sanding, these objects can tear the sandpaper. Always visually inspect your workpiece for these items. If they can't be removed, DO NOT sand the workpiece.
- **Excessive glue or finish:** Sanding workpieces with excess glue or finish will load up the abrasive, reducing its usefulness and lifespan.

Attaching Sandpaper

The Model W1828 sander uses 12" diameter pressure sensitive adhesive-backed (PSA) sanding discs. These are available in a variety of grits. The sandpaper can be replaced without removing the table.

To attach the sandpaper disc, do these steps:

1. DISCONNECT MACHINE FROM POWER!
2. Peel-off the old sandpaper, and clean the disc surface with mineral spirits, and wipe dry.
3. Peel back the protective layer on *one-half* of the sandpaper disc and fold it against the remaining half.
4. Slip the half with the protective layer between the disc and the table edge, as shown in **Figure 14**.
5. Position the exposed adhesive on the upper half of the sandpaper disc over the aluminum disc above the table. Once it is positioned evenly across the disc, press the adhesive firmly onto the surface.
6. Now rotate the disc so the lower half is above the table, peel-off the other half of the protective paper, as shown in **Figure 15**, then press the sandpaper disc firmly against the disc so adhesion is complete.



Figure 14. Slipping covered sandpaper between disc and table.



Figure 15. Removing the paper backing.

Disc Sanding

⚠ CAUTION

Always keep the workpiece on the side of the wheel that is rotating down toward the table. This will keep the workpiece from flying out of your hands from the rotational forces.

To use the sanding disc, do these steps:

1. DISCONNECT SANDER FROM POWER!
2. Set the angle of the table and miter gauge for your operation. Make sure the table is about $\frac{1}{16}$ " away from the sanding disc.
3. Connect the sander to power, turn it **ON**, and allow it to reach full speed.
4. Position the workpiece on the work table against the miter gauge.
5. With light, but firm pressure, push the workpiece into the down-spin side of the rotating disc. See Figures 16-18 for examples of disc sanding.



Figure 16. 90° disc sanding.



Figure 17. Miter sanding.



Figure 18. Sanding with table angled.

⚠ CAUTION

To reduce the risk of your fingers getting trapped between the work table and sanding disc, make sure the table is approximately $\frac{1}{16}$ " away from the sanding disc.

NOTICE

To prevent burning the workpiece and overloading the sanding disc, move the workpiece slowly back and forth from the left side of the sanding disc to the center.

Note: To perform sanding on compound-angle cuts, tilt the table and rotate the miter gauge to the appropriate angles.

ACCESSORIES

Disc Sander Accessories

The following Disc Sander accessories may be available through your local Woodstock International Inc. Dealer. If you do not have a dealer in your area, these products are also available through online dealers. Please call or e-mail Woodstock International Inc. Customer Service to get a current listing of dealers at: 1-800-840-8420 or at sales@woodstockint.com.

12" aluminum oxide PSA sanding discs are available in two packs:

Model	Grit
D1335	60 Grit
D1336	80 Grit
D1337	100 Grit
D1338	120 Grit
D1339	160 Grit
D1340	180 Grit
D1341	220 Grit



The **PRO-STICK**® abrasive surface cleaners can extend the life of your sanding discs. Simply press the cleaner lightly against moving sanding discs to remove clogged-up pitch and sawdust.

Size	Model
1 ³ / ₈ " x 1 ³ / ₈ " x 4 ¹ / ₄ "	W1304
1 ³ / ₈ " x 1 ³ / ₈ " x 8 ¹ / ₂ "	W1305
1 ¹ / ₂ " x 1 ¹ / ₂ " x 8 ¹ / ₂ "	W1306
2" x 2" x 12"	W1307



The Shop Fox **Deluxe Ceiling Mounted 3-Speed Air Cleaner, Model W1690**, is an essential machine for any shop creating dust. This machine filters out tiny dust particles that can raise big health concerns. Includes remote control.



OPERATIONS

MAINTENANCE

General

Regular periodic maintenance on your machine will ensure its optimum performance. Make a habit of inspecting your machine each time you use it.

Check for the following conditions and repair or replace when necessary:

- Loose mounting bolts.
- Worn switch.
- Worn or damaged cords and plugs.
- Worn or damaged sandpaper disc.
- Any other condition that could hamper the safe operation of this machine.

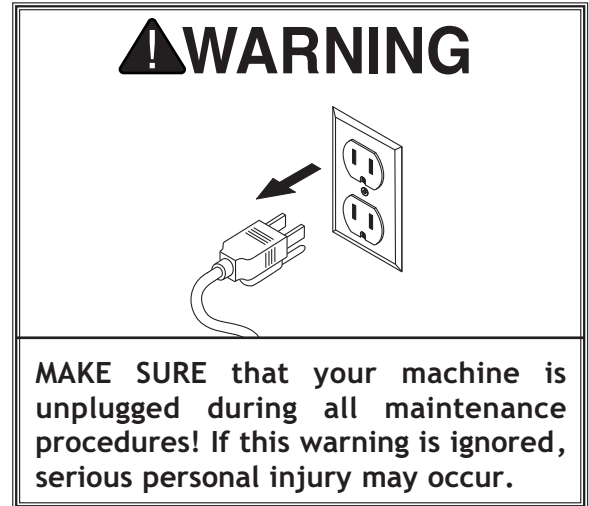

Cleaning

Frequently vacuum the wood chips and sawdust from the sander, then blow-off any remaining dust with compressed air. This is especially important for the motor. Sawdust build-up around the motor is a sure way to decrease its life span.

Table & Base

Tables can be kept rust-free with regular applications of products like SLIPIT®. For long term storage you may want to consider products like Boeshield T-9™.

Lubrication

Since all bearings are sealed and permanently lubricated, simply leave them alone until they need to be replaced. Do not lubricate them.

SERVICE

General

This section covers the most common service adjustments or procedures that may need to be made during the life of your machine.

If you require additional machine service not included in this section, please contact Woodstock International Technical Support at (360) 734-3482 or send e-mail to: tech-support@shopfox.biz.

Table/Disc Parallelism

The edge of the table must be parallel with the face of the sanding disc, and there should be a $1/16$ " gap between the two. This gap should be large enough so that the sandpaper does not rub against the table, but small enough so that the gap is not a pinch hazard.

Tools Needed	Qty
Wrench 10mm	1
Phillips Screwdriver #2.....	1
Fine Ruler	1

To make the table and sanding disc parallel, do these steps:

1. DISCONNECT MACHINE FROM POWER!
2. Loosen the six flat head screws and hex nuts that secure the table to the table support brackets.
3. Adjust the table so that there is a $1/16$ " gap (see Figure 19) between the 12" disc (with sandpaper installed) and the table, from left to right.
4. When the table is parallel with the sanding disc, tighten the flat head screws and hex nuts.
5. Spin the disc by hand to make sure the sandpaper is not touching the table.
 - If the sandpaper does touch the table as you spin the disc by hand, repeat Steps 2-5 until it does not.
6. Perform the **Miter Gauge Calibration** procedure on the next page to ensure the miter slot is perpendicular to the sanding disc.

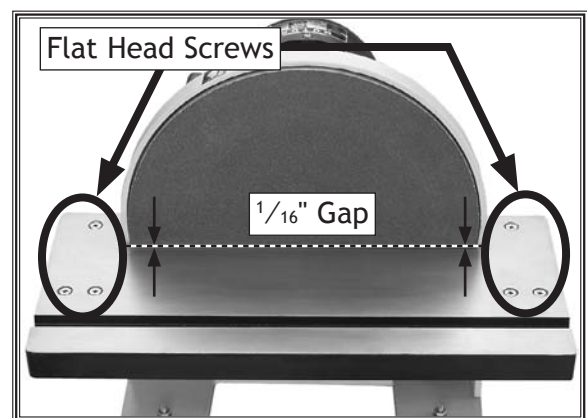
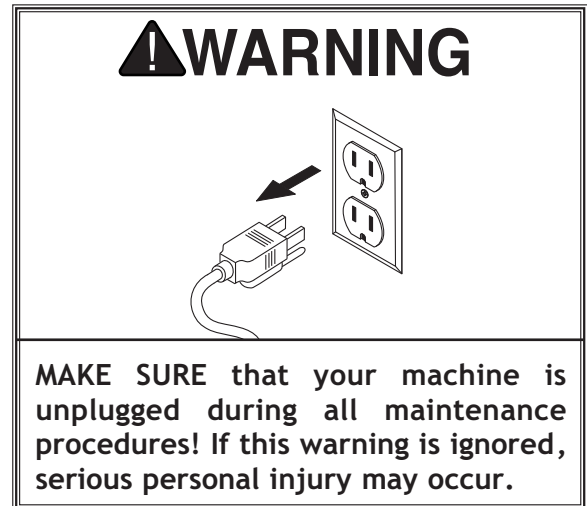

Figure 19. Table parallel with sanding disc.

SERVICE

Miter Gauge Calibration

The miter gauge should be perpendicular to the face of the disc when it is set at 90° and mounted in the table slot. If not, follow this procedure.

Tools Needed	Qty
Try Square or Machinist's Square	1
Phillips Screwdriver #1	1

To calibrate the miter gauge, do these steps:

1. DISCONNECT MACHINE FROM POWER!
2. Use a try square or machinist's square with one edge against the face of the miter gauge and the other against the disc face, as shown in **Figure 20**.
3. Loosen the lock knob on the miter gauge and adjust the face of the miter gauge so it is flush with the edge of the square, tighten the gauge lock knob, and verify the setting.
4. Loosen the degree scale pointer, position the pointer on 90°, then re-tighten the screw.
5. Re-check the miter scale accuracy with the square.



Figure 20. Squaring miter gauge to disc.

Table Tilt Calibration

When the table tilt is set to 0°, the table should be positioned perpendicular to the sanding disc face. If it is not, follow this procedure.

To calibrate the table tilt, do these steps:

1. DISCONNECT MACHINE FROM POWER!
2. Using a try square or machinist's square, set one edge on the table surface and the other against the face of the disc, as shown in **Figure 21**.
3. Loosen the table tilt lock handles and adjust the table angle until it is perfectly perpendicular to the disc, then tighten the lock handles while holding the table in place.
4. If the angle pointer stickers on both ends do not point to 0°, remove them and place them on the trunnion so they point to 0°.
5. Recheck the scale accuracy with the square.

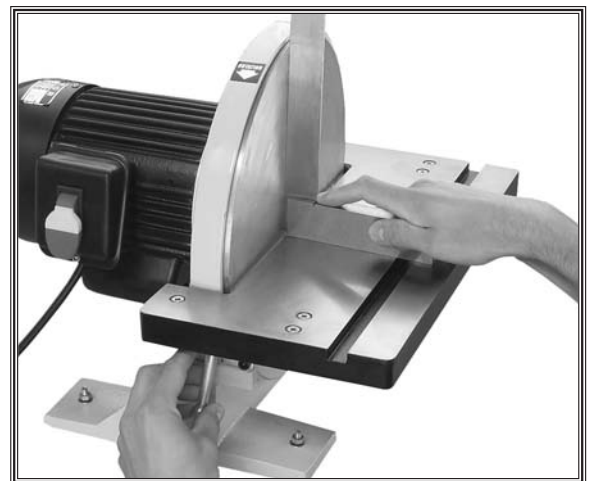
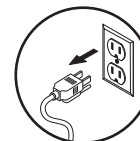

Figure 21. Squaring the table.

Troubleshooting

This section covers the most common problems and corrections with this type of machine. **WARNING! DO NOT** make any adjustments until power is disconnected and moving parts have come to a complete stop!



PROBLEM	POSSIBLE CAUSE	CORRECTIVE ACTION
Machine does not start.	<ol style="list-style-type: none"> 1. Switch disabling key removed. 2. Break or short in wiring, loose connections, plug or receptacle is corroded or miswired. 3. Power supply switched off/has incorrect voltage. 4. Blown fuse/tripped circuit breaker at main panel. 5. Motor connection wired incorrectly. 6. Motor ON/OFF switch at fault. 7. Start capacitor has blown. 8. Centrifugal switch at fault. 9. Motor at fault. 	<ol style="list-style-type: none"> 1. Re-install switch disabling key. 2. Trace/replace broken or corroded wires, fix loose connections, correct wiring. 3. Switch power supply on/verify voltage. 4. Correct the cause of overload, then reset/replace fuse or breaker. 5. Wire motor correctly (refer to inside junction box cover). 6. Replace switch. 7. Test/replace if at fault. 8. Adjust/replace centrifugal switch. 9. Test for shorted windings or bad bearings; repair or replace.
Machine has excessive vibration or noise.	<ol style="list-style-type: none"> 1. Workpiece loose or incorrectly secured. 2. Motor fan rubbing on fan cover. 3. Motor mounting loose. 4. Table tilt lock handle is loose. 5. Machine incorrectly mounted to bench. 6. Centrifugal switch out of adjustment; at fault. 7. Motor bearings worn or damaged. 	<ol style="list-style-type: none"> 1. Use correct holding fixture and re-clamp workpiece. 2. Fix/replace fan cover; replace loose or damaged fan. 3. Tighten mounting bolts/nuts; use thread locking fluid. 4. Tighten the lock handle. 5. Level/shim base; tighten/adjust mounting hardware. 6. Adjust/replace centrifugal switch. 7. Replace motor bearings or replace motor.
Machine stalls or slows when operating.	<ol style="list-style-type: none"> 1. Too much pressure when feeding workpiece 2. Workpiece is warped. 3. Workpiece is incorrect for machine. 4. Motor connection wired incorrectly. 5. Motor overheated. 6. Centrifugal switch at fault. 7. Motor at fault. 	<ol style="list-style-type: none"> 1. Reduce pressure when feeding workpiece. 2. Straighten workpiece or use a different one. 3. Only sand wood and ensure moisture is below 20%. 4. Review wiring diagram on motor cover; correct wire connections. 5. Let cool, clean motor, and reduce workload. 6. Adjust/replace centrifugal switch if available. 7. Test, repair, or replace motor.
Miter bar loose or binds in miter slot.	<ol style="list-style-type: none"> 1. Miter slot dirty or gummed up. 	<ol style="list-style-type: none"> 1. Carefully clean miter slot.
Workpiece angle incorrect or out of square.	<ol style="list-style-type: none"> 1. Miter gauge or table angle not adjusted correctly. 2. Table tilt is not calibrated correctly. 	<ol style="list-style-type: none"> 1. Properly adjust the miter gauge and (see Page 24). 2. Properly calibrate the table tilt (see Page 24).

SERVICE

PROBLEM	POSSIBLE CAUSE	CORRECTIVE ACTION
Sandpaper clogs quickly or burns.	<ol style="list-style-type: none"> 1. Sandpaper grit is too fine for the job. 2. Workpiece is too moist. 3. Sanding depth too aggressive. 4. Paint, varnish, pitch, or other coating is loading up sandpaper. 5. Sanding soft workpiece. 	<ol style="list-style-type: none"> 1. Replace with a coarser grit sandpaper. 2. Allow workpiece to dry out. 3. Reduce sanding depth or install coarser sandpaper. 4. Install a coarse grit sandpaper, or strip coating off before sanding. 5. Use different stock. Or, accept the characteristics of the stock and plan on cleaning/replacing discs frequently.
Glossy spots, burning, or streaks on workpiece.	<ol style="list-style-type: none"> 1. Sandpaper too fine for the desired finish. 2. Work held still for too long. 3. Workpiece is too moist. 4. Sanding stock with high residue. 5. Worn sandpaper. 6. Sanding depth too aggressive. 	<ol style="list-style-type: none"> 1. Use a coarser grit sandpaper. 2. Do not keep workpiece in one place for too long. 3. Allow workpiece to dry out. 4. Use different stock. Or, accept the characteristics of the stock and plan on cleaning/replacing sandpapers frequently. 5. Replace sandpaper. 6. Reduce sanding depth or install coarser sandpaper.
Abrasive rubs off easily.	<ol style="list-style-type: none"> 1. Sandpaper has been stored in an incorrect environment. 	<ol style="list-style-type: none"> 1. Store sandpaper flat and away from extremely dry, hot, or damp conditions.

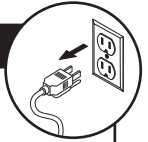

Electrical Safety Instructions

These pages are current at the time of printing. However, in the spirit of improvement, we may make changes to the electrical systems of future machines. Study this diagram carefully. If you notice differences between your machine and these wiring diagrams, call Woodstock International Technical Support at (360) 734-3482.

WARNING

1. **SHOCK HAZARD.** Working on wiring that is connected to a power source is extremely dangerous. Touching electrified parts will result in personal injury including but not limited to severe burns, electrocution, or death. Disconnect the power from the machine before servicing electrical components!
2. **QUALIFIED ELECTRICIAN.** Due to the inherent hazards of electricity, only a qualified electrician should perform wiring tasks on this machine. If you are not a qualified electrician, get help from one before attempting any kind of wiring job.
3. **WIRE CONNECTIONS.** All connections must be tight to prevent wires from loosening during machine operation. Double-check all wires disconnected or connected during any wiring task to ensure tight connections.
4. **WIRE/COMPONENT DAMAGE.** Damaged wires or components increase the risk of serious personal injury, fire, or machine damage. If you notice that any wires or components are damaged while performing a wiring task, replace those wires or components before completing the task.
5. **MOTOR WIRING.** The motor wiring shown in these diagrams is current at the time of printing, but it may not match your machine. Always use the wiring diagram inside the motor junction box.
6. **MODIFICATIONS.** Using aftermarket parts or modifying the wiring beyond what is shown in the diagram may lead to unpredictable results, including serious injury or fire.
7. **CAPACITORS/INVERTERS.** Some capacitors and power inverters store an electrical charge for up to five minutes after being disconnected from the power source. To avoid being shocked, wait at least this long before working on these components.
8. **ELECTRICAL REQUIREMENTS.** You **MUST** follow the electrical requirements at the beginning of this manual when connecting your machine to a power source.
9. **EXPERIENCING DIFFICULTIES.** If you are experiencing difficulties understanding the information included in this section, contact our Technical Support at (360) 734-3482.

NOTICE

The photos and diagrams included in this section are best viewed in color. You can view these pages in color at www.shopfox.biz.

WIRING DIAGRAM COLOR KEY

BLACK	BLUE	YELLOW	LIGHT BLUE
WHITE	BROWN	YELLOW GREEN	BLUE WHITE
GREEN	GRAY	PURPLE	TURQUOISE
RED	ORANGE	PINK	

Wiring Diagram

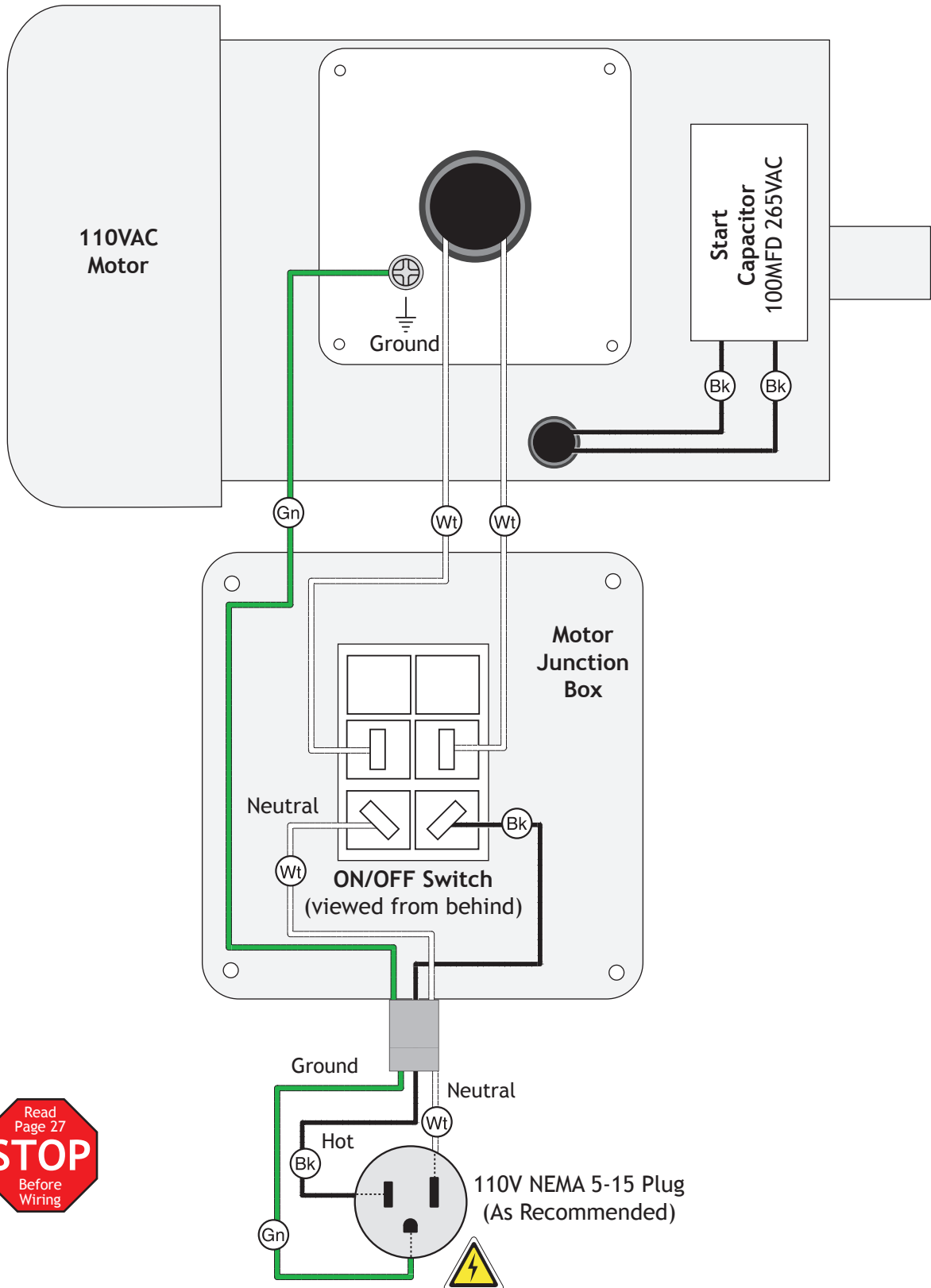

SERVICE

PARTS

Main

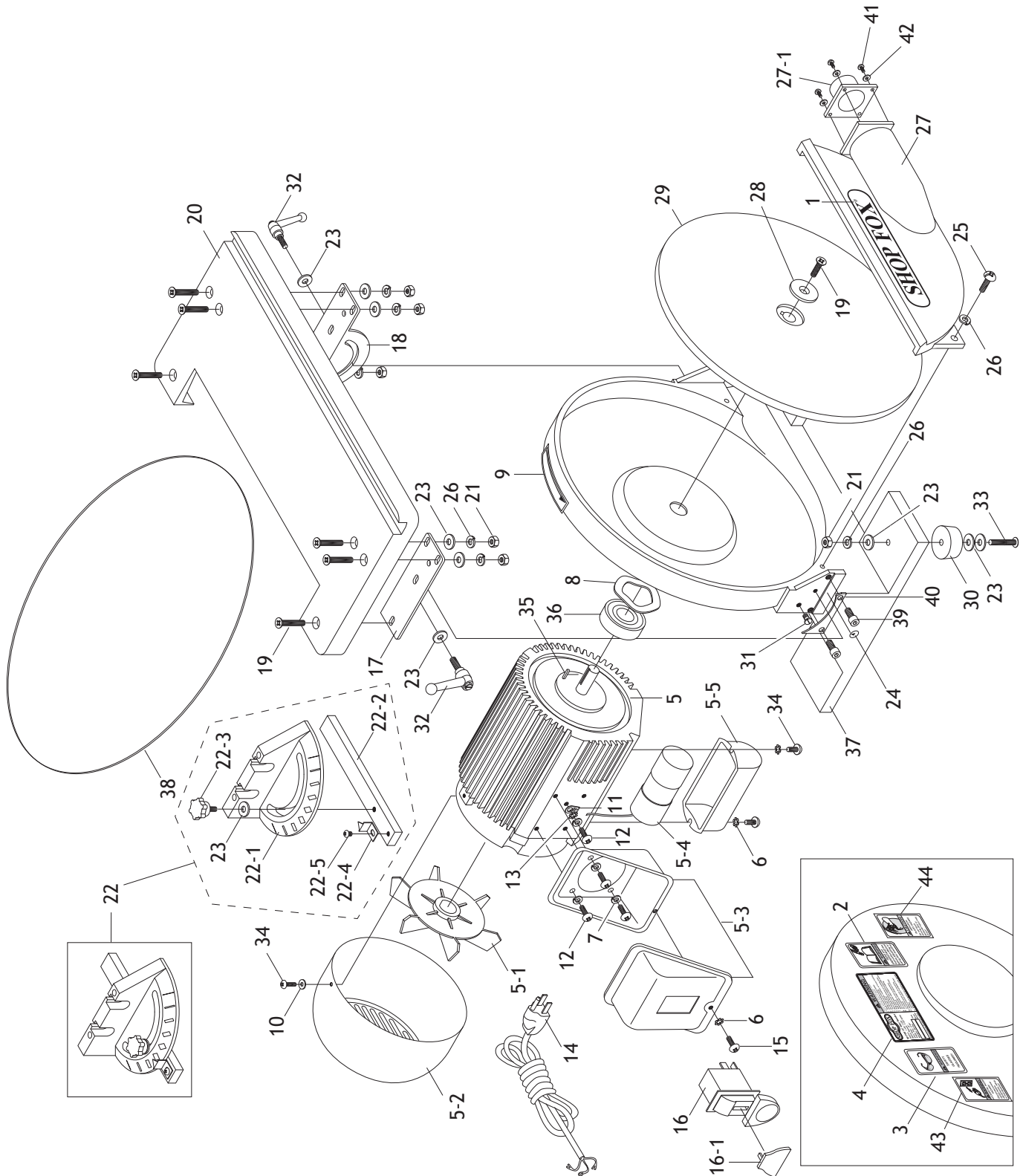

Main Parts List

REF	PART #	DESCRIPTION
1	X1828001	SHOP FOX LOGO LABEL
2	XLABEL-12	READ MANUAL LABEL
3	XLABEL-11	SAFETY GLASSES LABEL
4	X1828004	MACHINE ID LABEL
5	X1828005	MOTOR 1HP 110V 60 HZ
5-1	X1828005-1	MOTOR FAN
5-2	X1828005-2	FAN COVER
5-3	X1828005-3	MOTOR JUNCTION BOX
5-4	XPC100C	S CAPACITOR 100M 265V 1-3/8 X 3-1/8
5-5	X1828005-5	CAPACITOR COVER
6	XPTLW01M	EXT TOOTH WASHER 4MM
7	XPLW01M	LOCK WASHER 5MM
8	X1828008	WAVY WASHER 39MM
9	X1828009	ROTATION ARROW LABEL
10	XPW05M	FLAT WASHER 4MM
11	X1828011	GROUND INDICATOR LABEL
12	XPS09M	PHLP HD SCR M5-.8 X 10
13	XPTLW02M	EXT TOOTH WASHER 5MM
14	X1828014	CORD W/PLUG
15	XPS17M	PHLP HD SCR M4-.7 X 6
16	XPSW09	PADDLE SWITCH 110/220V
16-1	XPSW09-1	SWITCH KEY
17	X1828017	RIGHT TRUNNION
18	X1828018	LEFT TRUNNION
19	XPFH06M	FLAT HD SCR M6-1 X 20
20	X1828020	WORK TABLE
21	XPNO1M	HEX NUT M6-1
22	X1828022	MITER GAUGE ASSEMBLY

REF	PART #	DESCRIPTION
22-1	X1828022-1	MITER GAUGE BODY
22-2	X1828022-2	GAUGE SLIDE
22-3	X1828022-3	KNOB BOLT M6-.1 X 22
22-4	X1828022-4	ANGLE POINTER
22-5	XPS19M	PHLP HD SCR M5-.8 X 6
23	XPW03M	FLAT WASHER 6MM
24	X1828024	TABLE ANGLE REFERENCE LABEL
25	XPS26M	PHLP HD SCR M6-1 X 20
26	XPLW03M	LOCK WASHER 6MM
27	X1828027	COVER W/DUST CHUTE
27-1	X1828027-1	DUST CHUTE HOSE ADAPTER
28	X1828028	SANDING DISC WASHER 1/4" X 1-1/4"
29	X1828029	SANDING DISC
30	X1828030	RUBBER FOOT
31	X1828031	STOP SCREW
32	X1828032	TABLE LOCK LEVER ASSY
33	XPS47M	PHLP HD SCR M6-1 X 25
34	XPS07M	PHLP HD SCR M4-.7 X 8
35	XPK23M	KEY 5 X 5 X 25
36	XP6204ZZ	BALL BEARING 6204 ZZ
37	X1828037	BASE
38	X1828038	SANDING DISC 80 GRIT PSA
39	XPSB26M	CAP SCREW M6-1 X 12
40	X1828040	TRUNNION REST
41	XPS08M	PHLP HD SCR M5-.8 X 12
42	XPW02M	FLAT WASHER 5MM
43	XLABEL24	DISCONNECT POWER LABEL
44	X1828044	ABRASION HAZARD LABEL

WARNING

Safety labels warn about machine hazards and how to prevent machine damage or injury. The owner of this machine **MUST** maintain the original location and readability of all labels on this machine. If any label is removed or becomes unreadable, **REPLACE** that label before allowing the machine to enter service again. Contact Woodstock International, Inc. at (360) 734-3482 or www.shopfoxtools.com to order new labels.

Warranty Registration

Name _____

Street _____

City _____ State _____ Zip _____

Phone # _____ Email _____ Invoice # _____

Model # _____ Serial # _____ Dealer Name _____ Purchase Date _____

The following information is given on a voluntary basis. It will be used for marketing purposes to help us develop better products and services. Of course, all information is strictly confidential.

1. How did you learn about us?

Advertisement Friend Local Store
 Mail Order Catalog Website Other:

2. How long have you been a woodworker/metalworker?

0-2 Years 2-8 Years 8-20 Years 20+ Years

3. How many of your machines or tools are Shop Fox?

0-2 3-5 6-9 10+

4. Do you think your machine represents a good value? Yes No

5. Would you recommend Shop Fox products to a friend? Yes No

6. What is your age group?

20-29 30-39 40-49
 50-59 60-69 70+

7. What is your annual household income?

\$20,000-\$29,000 \$30,000-\$39,000 \$40,000-\$49,000
 \$50,000-\$59,000 \$60,000-\$69,000 \$70,000+

8. Which of the following magazines do you subscribe to?

<input type="checkbox"/> Cabinet Maker	<input type="checkbox"/> Popular Mechanics	<input type="checkbox"/> Today's Homeowner
<input type="checkbox"/> Family Handyman	<input type="checkbox"/> Popular Science	<input type="checkbox"/> Wood
<input type="checkbox"/> Hand Loader	<input type="checkbox"/> Popular Woodworking	<input type="checkbox"/> Wooden Boat
<input type="checkbox"/> Handy	<input type="checkbox"/> Practical Homeowner	<input type="checkbox"/> Woodshop News
<input type="checkbox"/> Home Shop Machinist	<input type="checkbox"/> Precision Shooter	<input type="checkbox"/> Woodsmith
<input type="checkbox"/> Journal of Light Cont.	<input type="checkbox"/> Projects in Metal	<input type="checkbox"/> Woodwork
<input type="checkbox"/> Live Steam	<input type="checkbox"/> RC Modeler	<input type="checkbox"/> Woodworker West
<input type="checkbox"/> Model Airplane News	<input type="checkbox"/> Rifle	<input type="checkbox"/> Woodworker's Journal
<input type="checkbox"/> Modeltec	<input type="checkbox"/> Shop Notes	<input type="checkbox"/> Other:
<input type="checkbox"/> Old House Journal	<input type="checkbox"/> Shotgun News	

9. Comments: _____

FOLD ALONG DOTTED LINE

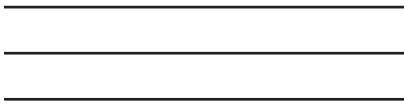

Place
Stamp
Here



WOODSTOCK INTERNATIONAL INC.
P.O. BOX 2309
BELLINGHAM, WA 98227-2309



FOLD ALONG DOTTED LINE

TAPE ALONG EDGES--PLEASE DO NOT STAPLE

WARRANTY

Woodstock International, Inc. warrants all Shop Fox machinery to be free of defects from workmanship and materials for a period of two years from the date of original purchase by the original owner. This warranty does not apply to defects due directly or indirectly to misuse, abuse, negligence or accidents, lack of maintenance, or reimbursement of third party expenses incurred.

Woodstock International, Inc. will repair or replace, at its expense and at its option, the Shop Fox machine or machine part, which in normal use has proven to be defective, provided that the original owner returns the product prepaid to a Shop Fox factory service center with proof of their purchase of the product within two years, and provides Woodstock International, Inc. reasonable opportunity to verify the alleged defect through inspection. If it is determined there is no defect, or that the defect resulted from causes not within the scope of Woodstock International Inc.'s warranty, then the original owner must bear the cost of storing and returning the product.

This is Woodstock International, Inc.'s sole written warranty and any and all warranties that may be implied by law, including any merchantability or fitness, for any particular purpose, are hereby limited to the duration of this written warranty. We do not warrant that Shop Fox machinery complies with the provisions of any law or acts. In no event shall Woodstock International, Inc.'s liability under this warranty exceed the purchase price paid for the product, and any legal actions brought against Woodstock International, Inc. shall be tried in the State of Washington, County of Whatcom. We shall in no event be liable for death, injuries to persons or property or for incidental, contingent, special or consequential damages arising from the use of our products.

Every effort has been made to ensure that all Shop Fox machinery meets high quality and durability standards. We reserve the right to change specifications at any time because of our commitment to continuously improve the quality of our products.



High Quality Machines and Tools

Woodstock International, Inc. carries thousands of products designed to meet the needs of today's woodworkers and metalworkers. Ask your dealer about these fine products:

BROSEA
PRECISION STOP BLOCK

JOINTER PAL[®]

Rotacator[®]

THE REBEL[®]

DURASTICK[®]

Gutmann[®]

BOARD BUDDIES[®]



Junglee[®]

PLANER PAL[®]

PARROT VISE[®]

SLICKPLANE[®]

PRO-STIK[®]
ABRASIVE BELT & DISC CLEANER

ACCU-SHARP[®]

Aluma-Classic[®]



STEELEX[®]
FINE TOOLS

STEELEX[®]
PLUS



WHOLESALE ONLY

WOODSTOCK INTERNATIONAL, INC.

Phone: (360) 734-3482 • Fax: (360) 671-3053 • Toll Free Fax: (800) 647-8801

P.O.Box 2309 • Bellingham, WA 98227

SHOPFOX.BIZ

Free Manuals Download Website

<http://myh66.com>

<http://usermanuals.us>

<http://www.somanuals.com>

<http://www.4manuals.cc>

<http://www.manual-lib.com>

<http://www.404manual.com>

<http://www.luxmanual.com>

<http://aubethermostatmanual.com>

Golf course search by state

<http://golfingnear.com>

Email search by domain

<http://emailbydomain.com>

Auto manuals search

<http://auto.somanuals.com>

TV manuals search

<http://tv.somanuals.com>