

MODEL W1713 16" SCROLL SAW



OWNER'S MANUAL (FOR MODELS MANUFACTURED SINCE 6/03)

Phone: (360) 734-3482 • Online Technical Support: tech-support@shopfox.biz



COPYRIGHT © AUGUST, 2003 BY WOODSTOCK INTERNATIONAL, INC.
WARNING: NO PORTION OF THIS MANUAL MAY BE REPRODUCED IN ANY SHAPE OR FORM WITHOUT
THE WRITTEN APPROVAL OF WOODSTOCK INTERNATIONAL, INC., REVISED MAY, 2010 (BL)

#5358DS Printed in China

WARNING!

This manual provides critical safety instructions on the proper setup, operation, maintenance and service of this machine/equipment.

Failure to read, understand and follow the instructions given in this manual may result in serious personal injury, including amputation, electrocution or death.

The owner of this machine/equipment is solely responsible for its safe use. This responsibility includes but is not limited to proper installation in a safe environment, personnel training and usage authorization, proper inspection and maintenance, manual availability and comprehension, application of safety devices, blade/cutter integrity, and the usage of personal protective equipment.

The manufacturer will not be held liable for injury or property damage from negligence, improper training, machine modifications or misuse.

WARNING!

Some dust created by power sanding, sawing, grinding, drilling, and other construction activities contains chemicals known to the State of California to cause cancer, birth defects or other reproductive harm. Some examples of these chemicals are:

- Lead from lead-based paints.
- Crystalline silica from bricks, cement and other masonry products.
- Arsenic and chromium from chemically-treated lumber.

Your risk from these exposures varies, depending on how often you do this type of work. To reduce your exposure to these chemicals: Work in a well ventilated area, and work with approved safety equipment, such as those dust masks that are specially designed to filter out microscopic particles.

Contents

INTRODUCTION	2	OPERATIONS	15
Woodstock Technical Support	2	General	15
About Your New Scroll Saw	2	Adjusting Hold-down Shoe & Blade Guard .	16
Specifications	2	Adjusting Air Nozzle	16
SAFETY	4	Adjusting Blade Tension.....	17
Standard Machinery Safety	4	Blade Information	17
Additional Safety for Scroll Saws	6	Blade Speed.....	18
ELECTRICAL	7	Blade Selection Chart	18
110V Operation	7	Standard Scroll Cutting.....	19
Extension Cords	7	Interior Scroll Cutting	19
Electrical Specifications	7	MAINTENANCE	20
SETUP	8	General	20
Unpacking	8	Cleaning	20
Inventory	8	Table	20
Workbench Mounting	8	Lubrication	21
Machine Placement	9	Motor Brushes.....	21
Cleaning Machine.....	9	SERVICE	22
Assembly.....	10	Troubleshooting.....	22
Installing Pin-End Blades	11	PARTS	23
Installing Plain End Blades.....	12	Main	23
Calibrating Table Tilt Scale	13	Machine Labels	25
Dust Collection	13	WARRANTY	29
Test Run.....	14		

USE THE QUICK GUIDE PAGE LABELS TO SEARCH OUT INFORMATION FAST!





INTRODUCTION

Woodstock Technical Support

This machine has been specially designed to provide many years of trouble-free service. Close attention to detail, ruggedly built parts and a rigid quality control program assure safe and reliable operation.

Woodstock International, Inc. is committed to customer satisfaction. Our intent with this manual is to include the basic information for safety, setup, operation, maintenance, and service of this product.

We stand behind our machines! In the event that questions arise about your machine, please contact Woodstock International Technical Support at (360) 734-3482 or send e-mail to: tech-support@shopfox.biz. Our knowledgeable staff will help you troubleshoot problems and process warranty claims.

If you need the latest edition of this manual, you can download it from <http://www.shopfox.biz>.

If you have comments about this manual, please contact us at:

Woodstock International, Inc.
 Attn: Technical Documentation Manager
 P.O. Box 2309
 Bellingham, WA 98227
 Email: manuals@woodstockint.com

About Your New Scroll Saw

Your new SHOP FOX® Model W1713 16" Scroll Saw is specially designed to provide many years of trouble-free service. Close attention to engineering detail, ruggedly built parts, and a rigid quality control program assure safe and reliable operation.

The Model W1713 features variable speed blade control, extra large working table, and cast iron construction. This Scroll Saw also offers a gooseneck work lamp, an air nozzle, a dust port, a 45° table tilt capacity, and easy blade change system. Uses standard plain and pin-end saw blades.

Specifications

Motor Size.....	1/8 HP, 120V, 60 Hz	Blade Stroke	3/4"
Motor Speed	Variable	Maximum Cutting width	16"
No Load Speed	550-1650 SPM	Minimum Cutting Thickness	2"
Amp Draw	1.2 A	Machine Weight	31 lbs.

Controls and Features

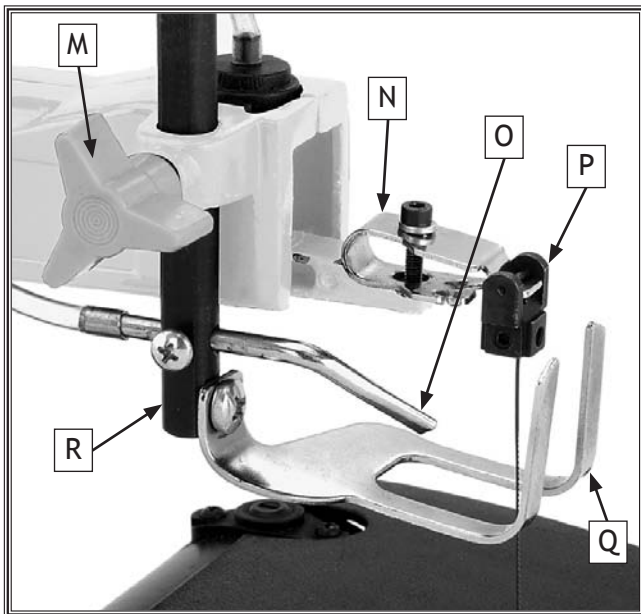
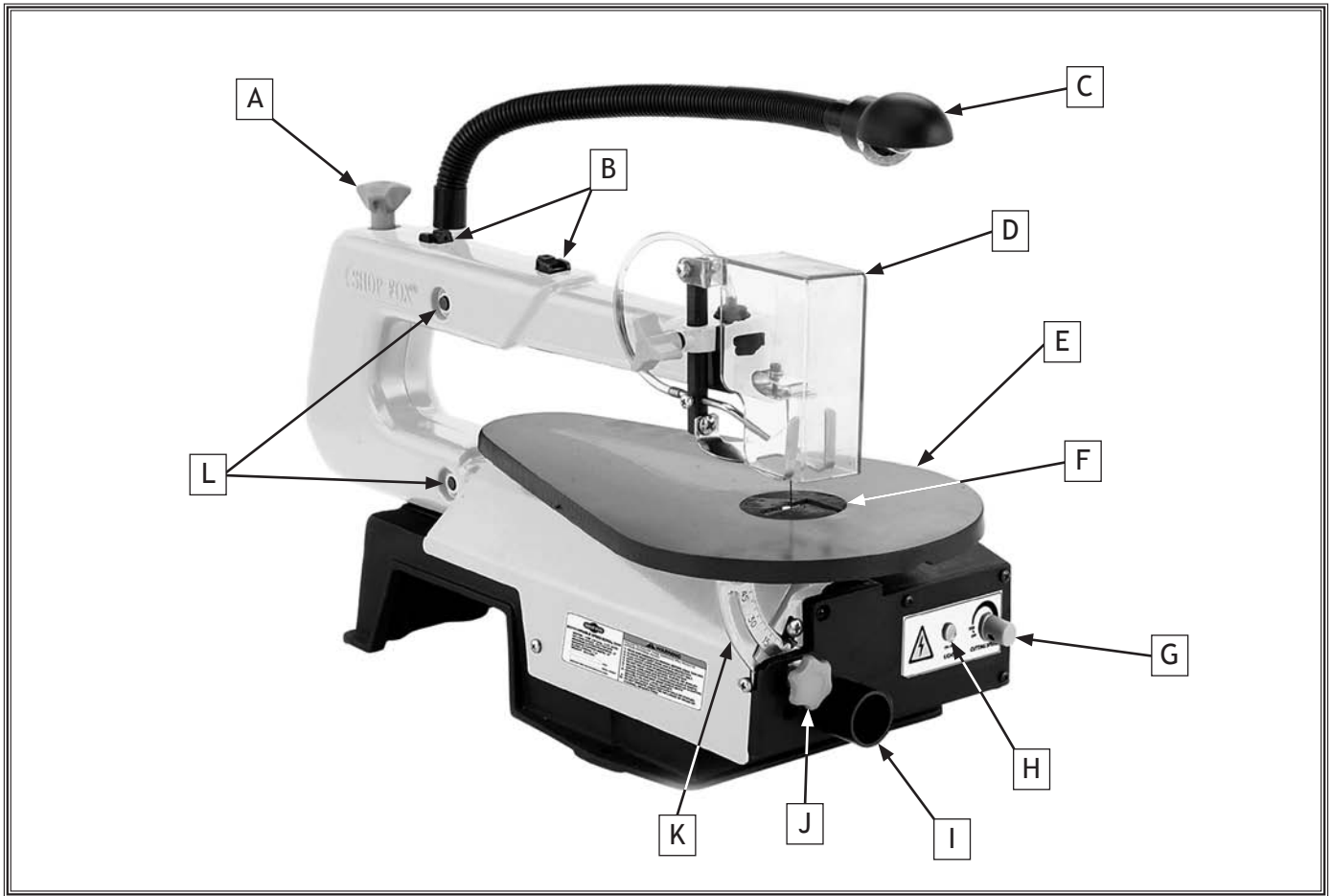

- A. Blade Tension Knob
- B. Blade Adapters
- C. Work Lamp
- D. Blade Guard
- E. Work Table
- F. Table Insert
- G. Variable Speed/Power Knob
- H. Light ON/OFF Button
- I. Dust Port 1 1/4"
- J. Table Tilt Lock Knob
- K. Table Tilt Scale
- L. Arm Bushings
- M. Hold-down Shoe Rod Lock Knob
- N. Upper Blade Holder
- O. Air Nozzle
- P. Blade Adapter (Mounted)
- Q. Hold-down Shoe
- R. Hold-down Shoe Rod

SAFETY

**READ MANUAL BEFORE OPERATING MACHINE.
FAILURE TO FOLLOW INSTRUCTIONS BELOW WILL
RESULT IN PERSONAL INJURY.**

⚠ DANGER Indicates an imminently hazardous situation which, if not avoided, **WILL** result in death or serious injury.

⚠ WARNING Indicates a potentially hazardous situation which, if not avoided, **COULD** result in death or serious injury.

⚠ CAUTION Indicates a potentially hazardous situation which, if not avoided, **MAY** result in minor or moderate injury.

NOTICE This symbol is used to alert the user to useful information about proper operation of the equipment, and/or a situation that may cause damage to the machinery.

Standard Safety Instructions

1. **READ THROUGH THE ENTIRE MANUAL BEFORE STARTING MACHINERY.** Machinery presents serious injury hazards to untrained users.
2. **ALWAYS USE ANSI APPROVED SAFETY GLASSES WHEN OPERATING MACHINERY.** Everyday eye-glasses only have impact resistant lenses—they are **NOT** safety glasses.
3. **ALWAYS WEAR A NIOSH APPROVED RESPIRATOR WHEN OPERATING MACHINERY THAT PRODUCES DUST.** Wood dust is a carcinogen and can cause cancer and severe respiratory illnesses.
4. **ALWAYS USE HEARING PROTECTION WHEN OPERATING MACHINERY.** Machinery noise can cause permanent hearing damage.
5. **WEAR PROPER APPAREL.** **DO NOT** wear loose clothing, gloves, neckties, rings, or jewelry which may get caught in moving parts. Wear protective hair covering to contain long hair and wear non-slip footwear.
6. **NEVER OPERATE MACHINERY WHEN TIRED, OR UNDER THE INFLUENCE OF DRUGS OR ALCOHOL.** Be mentally alert at all times when running machinery.
7. **ONLY ALLOW TRAINED AND PROPERLY SUPERVISED PERSONNEL TO OPERATE MACHINERY.** Make sure operation instructions are safe and clearly understood.
8. **KEEP CHILDREN AND VISITORS AWAY.** Keep all children and visitors a safe distance from the work area.
9. **MAKE WORKSHOP CHILD PROOF.** Use padlocks, master switches, and remove start switch keys.

10. **NEVER LEAVE WHEN MACHINE IS RUNNING.** Turn power **OFF** and allow all moving parts to come to a complete stop before leaving machine unattended.
11. **DO NOT USE IN DANGEROUS ENVIRONMENTS.** DO NOT use machinery in damp, wet locations, or where any flammable or noxious fumes may exist.
12. **KEEP WORK AREA CLEAN AND WELL LIT.** Clutter and dark shadows may cause accidents.
13. **USE A GROUNDED EXTENSION CORD RATED FOR THE MACHINE AMPERAGE.** Undersized cords overheat and lose power. Replace extension cords if they become damaged. DO NOT use extension cords for 220V machinery.
14. **ALWAYS DISCONNECT FROM POWER SOURCE BEFORE SERVICING MACHINERY.** Make sure switch is in OFF position before reconnecting.
15. **MAINTAIN MACHINERY WITH CARE.** Keep blades sharp and clean for best and safest performance. Follow instructions for lubricating and changing accessories.
16. **MAKE SURE GUARDS ARE IN PLACE AND WORK CORRECTLY BEFORE USING MACHINERY.**
17. **REMOVE ADJUSTING KEYS AND WRENCHES.** Make a habit of checking for keys and adjusting wrenches before turning machinery **ON**.
18. **CHECK FOR DAMAGED PARTS BEFORE USING MACHINERY.** Check for binding and alignment of parts, broken parts, part mounting, loose bolts, and any other conditions that may affect machine operation. Repair or replace damaged parts.
19. **USE RECOMMENDED ACCESSORIES.** Refer to the instruction manual for recommended accessories. The use of improper accessories may cause risk of injury.
20. **DO NOT FORCE MACHINERY.** Work at the speed for which the machine or accessory was designed.
21. **SECURE WORKPIECE.** Use clamps or a vise to hold the workpiece when practical. A secured workpiece protects your hands and frees both hands to operate the machine.
22. **DO NOT OVERREACH.** Keep proper footing and balance at all times.
23. **MANY MACHINES WILL EJECT THE WORKPIECE TOWARD THE OPERATOR.** Know and avoid conditions that cause the workpiece to "kickback."
24. **ALWAYS LOCK MOBILE BASES (IF USED) BEFORE OPERATING MACHINERY.**
25. **BE AWARE THAT CERTAIN DUST MAY BE HAZARDOUS** to the respiratory systems of people and animals, especially fine dust. Make sure you know the hazards associated with the type of dust you will be exposed to and always wear a respirator approved for that type of dust.

Additional Safety for Scroll Saws



⚠ WARNING
 READ and understand this entire manual before using this machine. Serious personal injury may occur if safety and operational information is not understood and followed. **DO NOT** risk your safety by not reading!

⚠ CAUTION
 USE this and other machinery with caution and respect. Always consider safety first, as it applies to your individual working conditions. No list of safety guidelines can be complete—every shop environment is different. Failure to follow guidelines could result in serious personal injury, damage to equipment or poor work results.

1. **WORKPIECE CONDITION.** Scroll saw safety begins with your lumber. Inspect your stock carefully before you begin a cut. If you have any doubts about the stability or structural integrity of your stock, **DO NOT CUT IT!**
2. **BLADE CONDITION.** To reduce the risk of blade breakage and to ensure good results, always inspect the blade for cracks and missing teeth before each use. Do not use a damaged or badly worn blade.
3. **HAND PLACEMENT.** The blade can quickly cut through flesh and bone. Never position fingers or hands in the path of the cut. Always wait for the blade to come to a complete stop on its own before clearing away cut-off pieces.
4. **WORKPIECE HANDLING.** If the workpiece should slip while cutting, your hand could be drawn into the moving blade. Always firmly support the workpiece on the table. Use jigs or support fixtures for small workpieces or complicated cut patterns.
5. **RELIEF CUTS.** To avoid excessive twisting of the blade that could cause it to break and throw metal debris in all directions, use relief cuts for curve cuts that tend to twist the blade.
6. **BLADE TENSION.** Make sure that blade has the proper tension before connecting the saw to power. A loose blade could become loose and be thrown away from the machine. A blade that has too much tension could become over stressed and break apart.
7. **ATTENTION TO WORK AREA.** Pay attention to the surrounding area when using the saw. Make sure bystanders are well away from the cutting operation and they are wearing safety glasses. Never leave the saw unattended when it is connected to power.
8. **OBSTRUCTIONS.** Plan and check your path of cut before starting the saw to avoid hitting an obstruction with the workpiece that could cause your hands to slip and contact the moving blade.
9. **BLADE GUARD.** The blade guard is designed to help keep your hands and fingers safe from the moving blade. Never operate this saw without the blade guard correctly and firmly installed as it was intended. Always keep the blade guard as close to the workpiece as possible without interfering with movement.
10. **BLADE CONTACT.** Starting the blade when it is in contact with the workpiece could cause blade breakage, or the workpiece to suddenly slip which could cause your hands to be drawn into the moving blade. Always wait for the blade to come to full speed before moving the workpiece into it.

ELECTRICAL

⚠ WARNING
 The machine must be properly set up before it is safe to operate. **DO NOT** connect this machine to the power source until instructed to do so in the "Test Run" portion of this manual.

110V Operation

The Model W1713 is wired for 110V operation. The power supply circuit used for this machine **MUST** be grounded and rated for the amperage given below. Never replace a circuit breaker with one of higher amperage without consulting a qualified electrician to ensure compliance with wiring codes.

This machine must be grounded! The electrical cord supplied with this machine comes with a grounding pin. If your outlet does not accommodate a ground pin, have it replaced by a qualified electrician.

If you are unsure about the wiring codes in your area or you plan to connect your machine to a shared circuit, you may create a fire or circuit overload hazard—consult a qualified electrician to reduce this risk.

Extension Cords

We do not recommend using an extension cord; however, if you have no alternative, use the following guidelines:

- Use a cord rated for Standard Service (S).
- Do not use an extension cord longer than 50 feet.
- Ensure that the cord has a ground wire and pin.
- Use the gauge size listed below as a minimum.

Electrical Specifications

Operating Voltage	Amp Draw	Min. Circuit Size	Plug/Recommended Plug	Extension Cord
110V Operation	1.2 Amps	15 Amps	NEMA 5-15	16 Gauge, 3-Wire

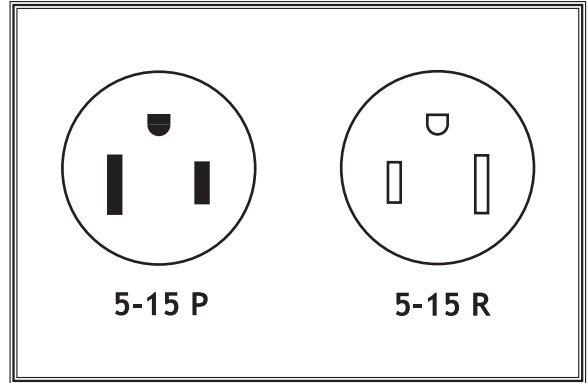

Figure 1. NEMA 5-15 plug and receptacle.

⚠ WARNING

DO NOT work on your electrical system if you are unsure about electrical codes and wiring! Seek assistance from a qualified electrician. Ignoring this warning can cause electrocution, fire, or machine damage.

ELECTRICAL

SETUP

Unpacking

This machine has been carefully packaged for safe transportation. If you notice the machine has been damaged during shipping, please contact your authorized Shop Fox dealer immediately.

Inventory

The following is a description of the main components shipped with the Model W1713. Lay the components out to inventory them.

Note: If you can't find an item on this list, check the mounting location on the machine or examine the packaging materials carefully. Occasionally we pre-install certain components for safer shipping.

Box Inventory	Qty
A. Scroll Saw Assembly.....	1
B. Hex Wrench 4mm.....	1
C. T-Handle Hex Wrench 3mm.....	1
D. Pin-End Blades 15 & 18 TPI.....	2
E. Blade Guard.....	1
F. Blade Adapters.....	2

Workbench Mounting

The strongest workbench mounting option is a "Through Mount" where holes are drilled all the way through the workbench, and hex bolts, washers, and hex nuts are used to secure the drill press to the workbench, as illustrated in **Figure 2**.

Another option for mounting is a "Direct Mount" where the machine is simply secured to the workbench with a lag screw, as illustrated in **Figure 3**.

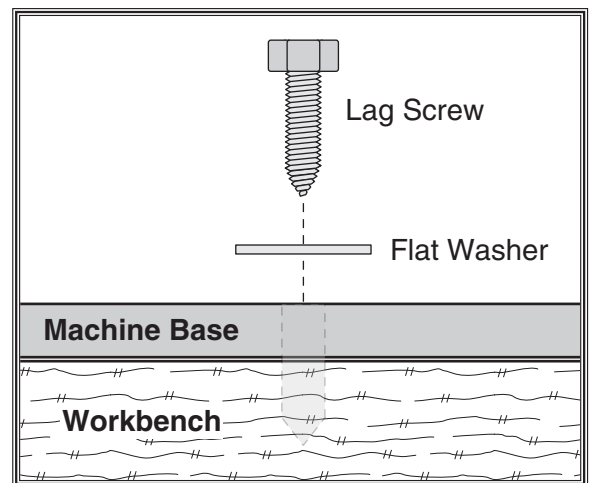
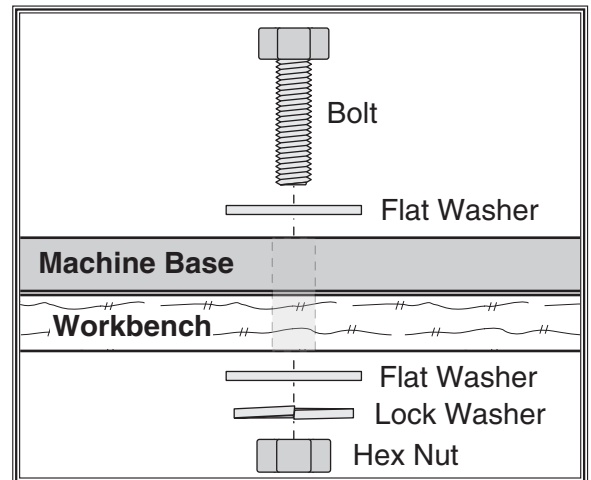
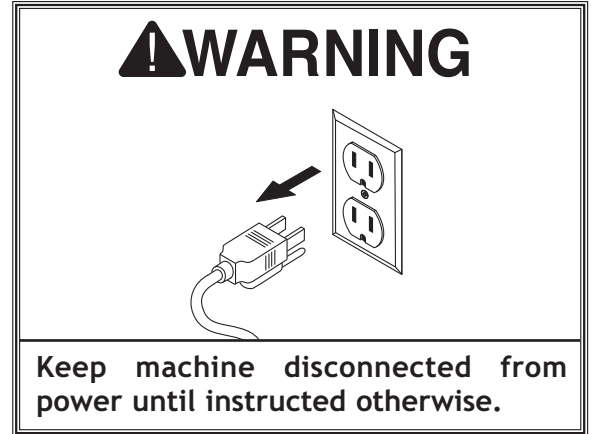

SETUP

Machine Placement

- **Workbench Load:** This machine distributes a heavy load in a small footprint. Some workbenches may require additional bracing to support both machine and operator.
- **Working Clearances:** Consider existing and anticipated needs, size of material to be processed through the machine, and space for auxiliary stands, work tables or other machinery when establishing a location for your Machine Type.
- **Lighting:** Lighting should be bright enough to eliminate shadow and prevent eye strain.
- **Electrical:** Electrical circuits must be dedicated or large enough to handle amperage requirements. Outlets must be located near each machine, so power or extension cords are clear of high-traffic areas. Follow local electrical codes for proper installation of new lighting, outlets, or circuits.

	<p>⚠ CAUTION MAKE your shop “child safe.” Ensure that your workplace is inaccessible to children by closing and locking all entrances when you are away. NEVER allow untrained visitors in your shop when assembling, adjusting or operating equipment.</p>
--	---

Cleaning Machine

The table and other unpainted parts of your scroll saw are coated with a waxy grease that protects them from corrosion during shipment. Clean this grease off with a solvent cleaner or citrus-based degreaser. DO NOT use chlorine-based solvents such as brake parts cleaner or acetone—if you happen to splash some onto a painted surface, you will ruin the finish.

	<p>⚠ WARNING NEVER clean with gasoline or other petroleum-based solvents. Most have low flash points, which make them extremely flammable. A risk of explosion and burning exists if these products are used. Serious personal injury may occur if this warning is ignored!</p>
--	---

	<p>⚠ CAUTION ALWAYS work in well-ventilated areas far from possible ignition sources when using solvents to clean machinery. Many solvents are toxic when inhaled or ingested. Use care when disposing of waste rags and towels to be sure they DO NOT create fire or environmental hazards.</p>
--	--

SETUP

Assembly

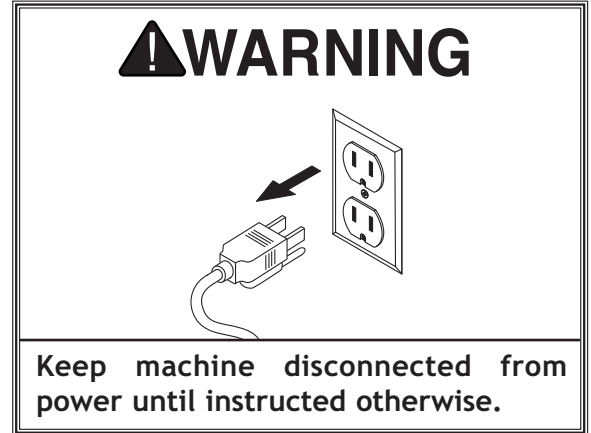
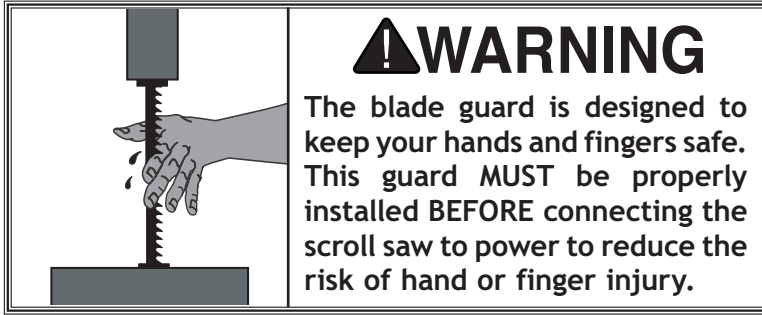

Tools Needed	Qty
Phillips Screwdriver #2.....	1
Wrench 8mm.....	1

To install the blade guard, do these steps:

1. Make sure the saw is disconnected from power.
2. Use the pre-installed Phillips head mounting screw, hex nut, and washers to install the blade guard onto the top of the hold-down shoe rod, as shown in **Figure 4**.

Note: *Over-tightening the mounting screw could crack the plastic arms of the blade guard.*

3. Pivot the guard up-and-down to ensure that it moves smoothly. If necessary, loosen the mounting screw until the movement is smooth.

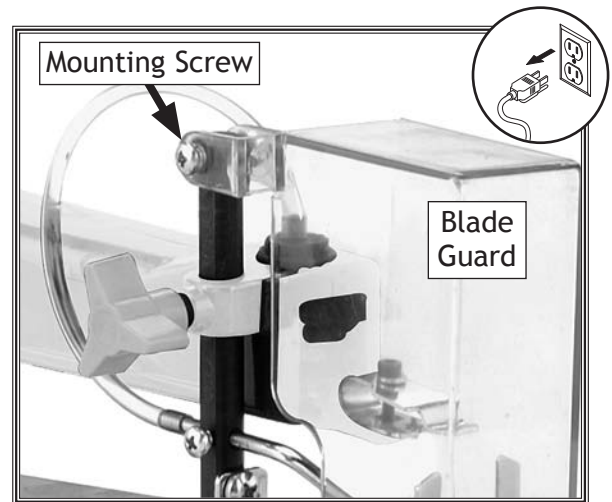

Figure 4. Blade guard properly installed.

Installing Pin-End Blades

Scroll saw blades are classified as either "pin-end" (mounting pins in the ends of the blade) or "plain end" (no pins). The blades included with your scroll saw are pin-end blades.

To install a pin-end blade, do these steps:

1. DISCONNECT MACHINE FROM POWER!
2. Rotate the blade tension knob counterclockwise to decrease the blade tension.
3. Remove the table insert.
4. Slide the saw blade down through the table hole so that the teeth face down and forward.
5. Position the lower pin-ends underneath the V-notch in the lower blade holder, as shown in **Figure 5**.

Note: Attempt to wiggle the blade end back-and-forth with slight pressure to make sure the pins are seated in the indents of the blade holder.

6. Press the upper blade holder down, then slide the upper pin-ends onto the V-notch of the upper blade holder, as shown in **Figure 6**.
7. Replace the table insert.
8. Properly tension the blade (refer to **Adjusting Blade Tension** on **Page 17** for detailed instructions).

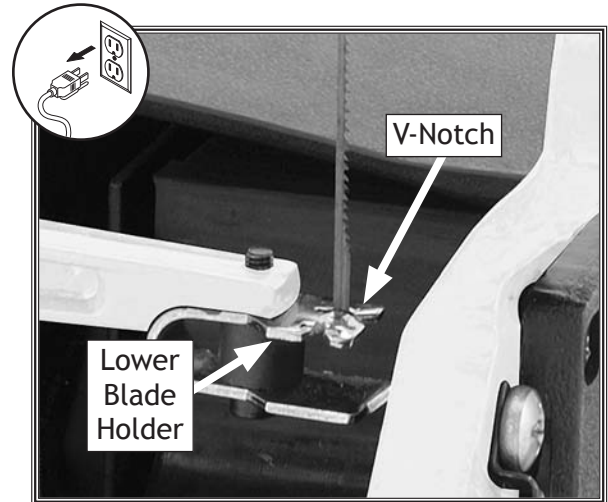

Figure 5. Pin-end blade properly mounted onto the lower blade holder.

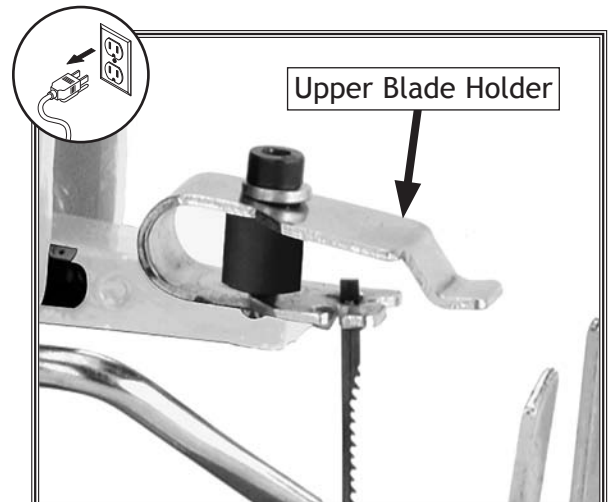

Figure 6. Pin-end blade properly mounted onto the upper blade holder.

Installing Plain End Blades

The V-notches of the upper and lower blade holders are designed to hold pin-end blades. However, with the use of the blade adapters, plain end blades that do not have the mounting pins can be used with your scroll saw.

Tools Needed	Qty
Hex Wrench 4mm	1

To install a plain end blade, do these steps:

1. DISCONNECT MACHINE FROM POWER!
2. Rotate the blade tension knob counterclockwise to decrease the blade tension.
3. Remove the table insert.
4. Loosen the blade adapter set screws to allow the saw blade ends to slide through the adapters, as illustrated in **Figure 7**.

Note: The set screws can be threaded into either set of adapter holes depending on whether side cutting or straight cutting is desired.

5. Thread one set screw in until it just makes contact with the blade. Keep the other set screw loose for now, as illustrated in **Figure 7**.
6. Without letting the adapters slip off the ends of the blade, place them in the indents on the top arm, as illustrated in **Figure 8**, with the set screws that are in contact with the blade facing down.

Note: Performing Step 6 will correctly set the overall length of the assembly to properly fit on the blade holders.

7. Fully tighten the top adapter set screws to firmly secure the blade with the adapters.
8. Slide one end of the blade assembly through the table hole and place the adapter over the mounting arm of the blade holder, then press the upper blade holder down and mount the other adapter over its mounting arm (see **Figure 9**).
9. Replace the table insert, then properly tension the blade (refer to **Adjusting Blade Tension** on **Page 17** for detailed instructions).

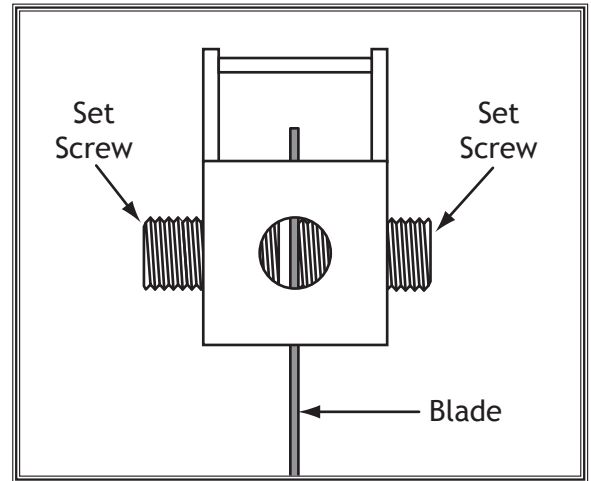

Figure 7. Plain end blade inserted and secured into a blade adapter.

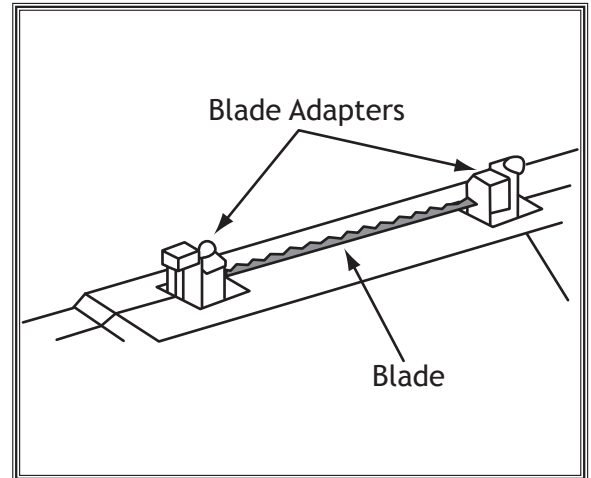

Figure 8. Blade with the blade adapters inserted into the adapter indents.

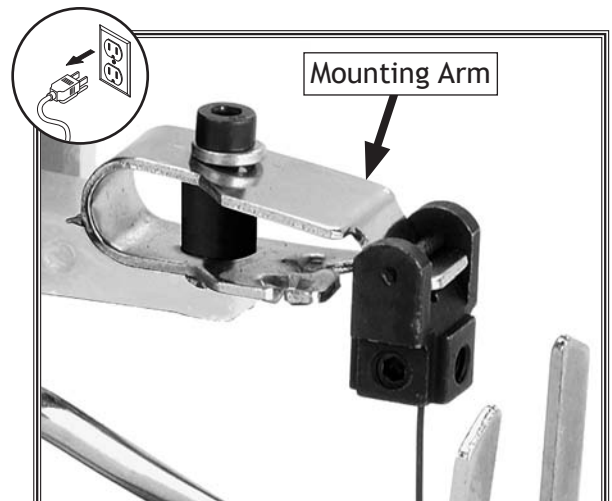

Figure 9. Plain end blade and adapter mounted on the upper blade holder.

SETUP

Calibrating Table Tilt Scale

The table lock knob and tilt scale are used to tilt the table for horizontal angle cuts.

Note: *The table tilt scale is only an approximate scale and should not be used when precise angle measurements are required for the operation.*

Tools Needed	Qty
Phillips Screwdriver #2.....	1
Wrench 10mm	1

To calibrate the table tilt scale, do these steps:

1. DISCONNECT MACHINE FROM POWER!
2. Loosen the jam nut on the table stop bolt shown in **Figure 10**, then thread the stop bolt in so that it will not interfere with the table adjustment.
3. Loosen the table lock knob (see **Figure 11**).
4. Place a small machinist's square up against the blade, adjust the table tilt until the table is flat against the bottom of the square, then re-tighten the lock knob.
5. If necessary, use the Phillips head screw on the pointer to adjust the pointer tip to the zero mark on the scale.
6. Thread the table stop bolt up so that it just contacts the bottom of the table, then secure it in place with the jam nut.

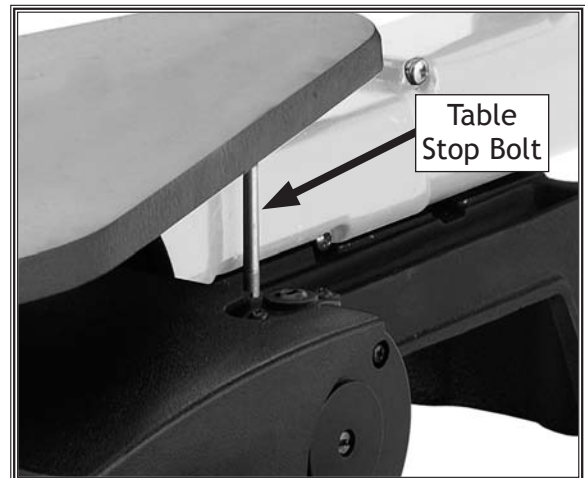

Figure 10. Table stop bolt.

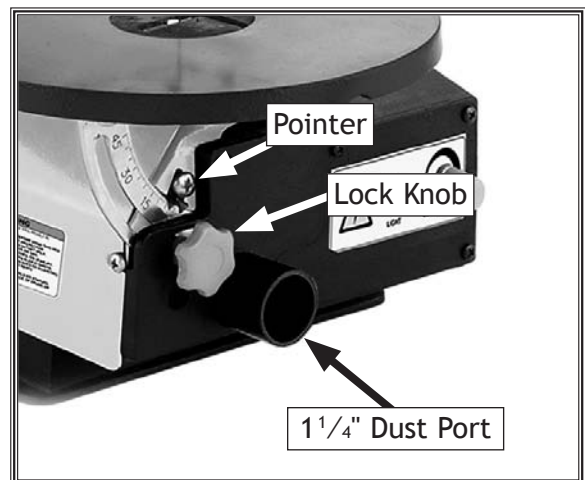

Figure 11. Table tilt controls and scroll saw dust port.

Dust Collection

We recommend that you connect the 1 1/4" dust port of your scroll saw (see **Figure 11**) to a shop vacuum to keep the wood debris from accumulating underneath the table insert, which could interfere with blade movement.

SETUP

Test Run

Once the assembly is complete, test run your scroll saw to make sure it runs properly.

If, during the test run, you cannot easily locate the source of an unusual noise or vibration, stop using the machine immediately, then review the **Troubleshooting** on **Page 22**.

If you still cannot remedy a problem, contact our Tech Support at (360) 734-3482 for assistance.

To test run the saw, do these steps:

1. Make sure you understand the safety instructions at the beginning of the manual, and verify that the machine is setup properly.
2. Ensure all tools and objects used during set up are cleared away from the machine.
3. Make sure the blade is properly installed and tensioned.
4. Connect the machine to the power source.
5. Rotate the variable speed/power knob clockwise to turn the machine **ON**.
6. Listen to and watch for abnormal noises or actions. The machine should run smoothly with little or no vibration or rubbing noises.
 - Strange or unusual noises should be investigated and corrected before operating the machine further. Always disconnect the machine from power when investigating or correcting potential problems.
7. Turn the machine **OFF**.

WARNING



Projectiles thrown from the machine could cause serious eye injury. Wear safety glasses to reduce the risk of injury.

WARNING

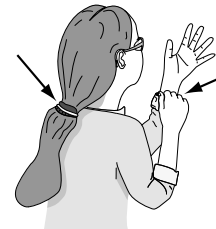

Loose hair and clothing could get caught in machinery and cause serious personal injury. Keep loose clothing rolled up and long hair tied up and away from machinery.

OPERATIONS

General

This machine will perform many types of operations that are beyond the scope of this manual. Many of these operations can be dangerous or deadly if performed incorrectly.

The instructions in this section are written with the understanding that the operator has the necessary knowledge and skills to operate this machine. **If at any time you are experiencing difficulties performing any operation, stop using the machine!**

If you are an inexperienced operator, we strongly recommend that you read books or trade articles, or seek training from an experienced scroll saw operator before performing any unfamiliar operations. **Above all, your safety should come first!**

WARNING



READ and understand this entire instruction manual before using this machine. Serious personal injury may occur if safety and operational information is not understood and followed. **DO NOT** risk your safety by not reading!

WARNING

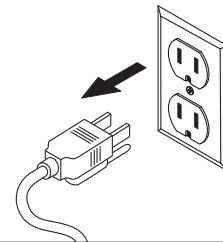

DO NOT investigate problems or adjust the machine while it is running. Wait until the machine is turned **OFF**, unplugged and all working parts have come to a complete stop before proceeding!

WARNING



Always wear safety glasses when operating this machine. Failure to comply may result in serious personal injury.

Adjusting Hold-down Shoe & Blade Guard

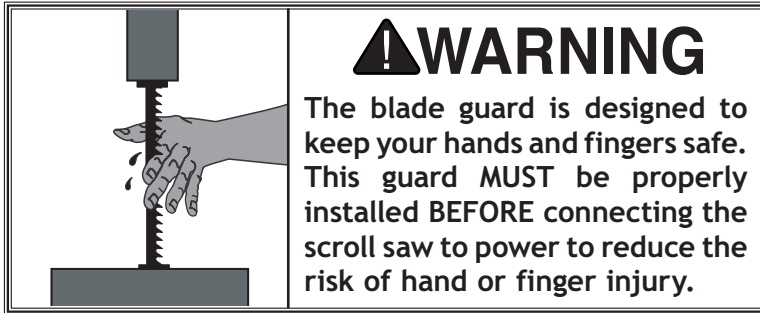

The hold-down shoe and blade guard are mounted on the hold-down shoe rod and are adjusted together. The hold-down shoe is designed to keep the workpiece from raising up with the force of the moving blade, and the blade guard is designed to keep debris from flying at the operator and to be a barrier between the blade and the operator's hands.

To adjust the hold-down shoe and blade guard, do these steps:

1. DISCONNECT MACHINE FROM POWER!
2. Loosen the hold-down shoe rod lock knob, then adjust the shoe until it is as close as possible and flat to the workpiece without interfering with its smooth movement across the table (see Figure 12).

Note: When you require the table to be tilted for your cutting operation, use the shoe screw to adjust the shoe so that it remains flat to the workpiece.

3. Re-tighten the rod lock knob and re-check for smooth workpiece movement.

Adjusting Air Nozzle

The air nozzle blows air at the cutting location to keep wood debris away from the line of the cut. Use the air nozzle screw shown in Figure 12 to adjust the position of the nozzle that best suits your operation.

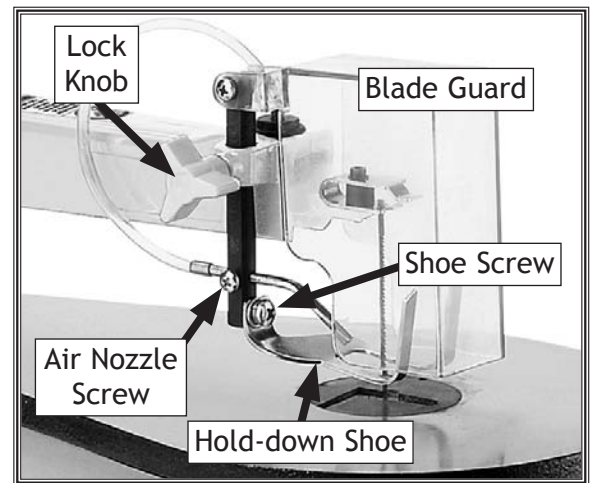

Figure 12. Hold-down shoe/blade guard and air nozzle controls.

Adjusting Blade Tension

Having proper blade tension is critical to safe cutting operations that produce good results. Blades that are tensioned correctly will also last longer and are less likely to break during the cutting operation. However, finding the correct amount of tension for each type of blade is a matter of trial-and-error and experience.

If the blade is tensioned too tight, the blade could break and cause serious personal injury from flying debris. If the blade is tensioned too loose, the blade will likely fall off during the cutting operation and cause injury hazards.

Get into the habit of plucking the saw blade like a guitar string before every use. With time and experience, you will recognize the distinct sound that indicates the proper amount of blade tension.

Turn the blade tension knob shown in **Figure 13** clockwise to increase the blade tension, and counterclockwise to decrease it.



Figure 13. Blade tension knob.

Blade Information

Important issues regarding blade performance:

- Typically, a scroll saw blade will stay sharp from 1/2 to 2 hours of use, depending on how the blade is used and the type of material being cut.
- Best cutting results will be achieved when cutting workpieces less than 1" thick.
- When cutting workpieces thicker than 1", move the workpiece through the blade very slowly.
- Blades will dull quickly when cutting plywood, hardwoods, and laminates.
- Exerting excessive side pressure on the blade greatly increases the chance of blade breakage.

Blade Speed

The blade speed can be varied between 550 and 1650 SPM (strokes per minute). Blade speed adjustment is made with the variable speed/power knob on the front of the scroll saw, as shown in Figure 14.

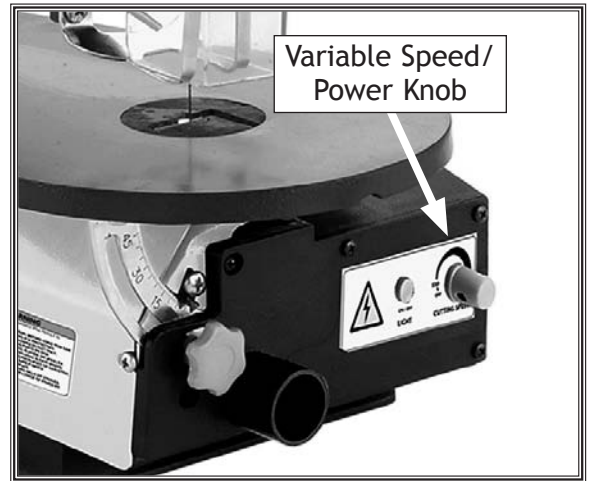

Figure 14. Variable speed/power knob.

Blade Selection Chart

Use the information in the chart below as a guideline for selecting the right blade and blade speed for your operation.

Teeth Per Inch	Width	Thickness	SPM	Workpiece Material
10 TPI	0.110"	0.020"	1200-1650	General purpose blade for cutting hard and soft woods between $\frac{3}{16}$ "-2". Also good for plastics, paper, felt, and bone.
15 TPI	0.110"	0.020"	700-1200	Thin wood and plastic between $\frac{3}{32}$ "- $\frac{1}{2}$ ".
18 TPI	0.095"	0.010"	550-700	Good for tight radius cutting in thin hard and soft woods between $\frac{3}{32}$ "- $\frac{1}{8}$ ". Also good for thin pieces of bone, ivory, plastics and veneer.

Figure 15. Blade selection chart.

Standard Scroll Cutting

For standard scroll cutting, follow the pattern line on the workpiece by pushing and turning the workpiece at the same time, which allows the kerf of the cut to make way for the turn.

DO NOT turn the workpiece without pushing it through the blade at the same time; otherwise, the blade could twist and break.

Interior Scroll Cutting

The scroll saw can be used to make internal cuts without having to cut through the perimeter of the workpiece.

To perform an interior scroll cutting operation, do these steps:

1. DISCONNECT MACHINE FROM POWER!
2. Drill a 1/4" hole in the workpiece inside the waste area of the internal cut.
3. Remove the table insert and the blade from the saw.

Note: *The workpiece must be wider than the table insert hole so that it will not fall through the table during the cutting operation. If necessary, use a jig or support form.*

4. Insert the blade through the previously drilled hole in the workpiece.

Note: *If using a plain end blade, remove one blade adapter to allow the blade to be inserted through the workpiece, then re-install the adapter on the blade.*

5. Correctly re-install the blade.
6. Properly adjust the hold-down shoe and guard, connect the saw to power, then perform the cut.
7. When finished, disconnect the saw from power, then remove the blade from the saw and workpiece and re-install it back on the saw.

MAINTENANCE

General

Regular periodic maintenance on your machine will ensure its optimum performance. Make a habit of inspecting your machine each time you use it.

Check for the following conditions and repair or replace when necessary:

- Loose mounting bolts.
- Worn switch.
- Worn or damaged cords and plugs.
- Any other condition that could hamper the safe operation of this machine.

Cleaning

Frequently blow-off sawdust with compressed air. This is especially important for the internal working parts and motor. Dust build-up around the motor is a sure way to decrease its life span. Connect the dust port to a shop vacuum, remove the table insert, and use compressed air to force the debris from under the table through the dust port.

Table

Tables can be kept rust-free with regular applications of products like SLIPIT®. For long term storage you may want to consider products like Boeshield T-9™.

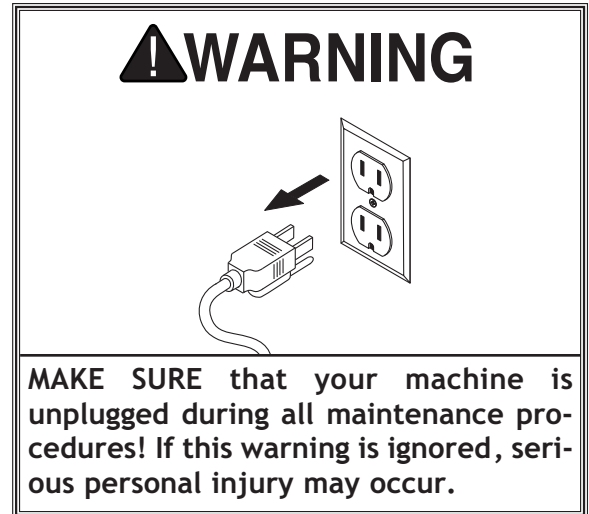

MAINTENANCE

Lubrication

The motor bearings are lubricated and sealed at the factory. Merely leave them alone unless they need to be replaced.

The upper and lower arms have two bushings each that require lubrication after every 8 hours of machine use.

To lubricate the arm bushings, do these steps:

1. DISCONNECT MACHINE FROM POWER!
2. Remove the plastic caps over the bushings to expose their ends (see **Figure 16**).
3. Lay the saw on its side as flat as possible, then apply a generous amount of light machine oil to the two cups around the bushing ends. Let the oil seep into the bushings for an hour or two.
4. Wipe off the excess oil, turn the saw over, and repeat **Step 3** to the remaining two bushings.
5. Replace the plastic caps before beginning operation to keep dust and debris from reaching the bushings.



Figure 16. Plastic caps removed to expose the arm bushing ends.

Motor Brushes

Over time the motor brushes will wear. Periodically, remove and examine them. Replace them if they are damaged, severely blackened with carbon build-up, or less than 1/4" in length.

Tools Needed	Qty
Standard Screwdriver	1

To inspect/replace the motor brushes, do these steps:

1. DISCONNECT MACHINE FROM POWER!
2. Remove the plastic caps securing the motor brushes (see **Figure 17**). The top cap is accessible from the top of the motor, and the bottom cap is accessible through a hole on the bottom of the base.
3. Pull the brush assemblies from the holes and inspect them for damage or wear. Replace them if necessary.
4. After replacing the brush assemblies, secure them with the plastic caps.

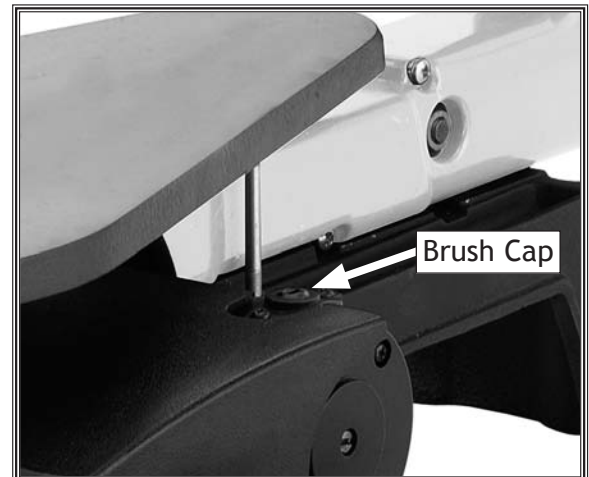
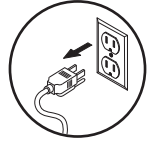

Figure 17. Top motor brush cap.

MAINTENANCE

SERVICE

Troubleshooting



This section covers the most common problems and corrections with this type of machine. If you require additional machine service not included in this section, please contact Woodstock International Technical Support at (360) 734-3482 or send e-mail to: tech-support@shopfox.biz. **WARNING! DO NOT make any adjustments until power is disconnected and moving parts have come to a complete stop!**

PROBLEM	POSSIBLE CAUSE	CORRECTIVE ACTION
Motor will not start; circuit breaker trips.	<ol style="list-style-type: none"> 1. Short circuit in line cord or plug; circuit breaker at fault. 2. Variable speed/power switch at fault. 3. Motor at fault. 4. Circuit board at fault 5. Low voltage. 	<ol style="list-style-type: none"> 1. Disconnect power, and inspect line cord and circuit for electrical shorts and repair; replace circuit breaker. 2. Test/replace variable speed/power switch. 3. Test/replace motor. 4. Test/replace circuit board. 5. Have the line voltage checked (110-120V required).
Motor slows or stalls during operation.	<ol style="list-style-type: none"> 1. Too much pressure applied to the workpiece. 2. Low voltage. 3. Motor brushes worn or damaged. 	<ol style="list-style-type: none"> 1. Reduce the feed rate and pressure on the workpiece. 2. Have the line voltage checked (110-120V required). 3. Inspect/replace motor brushes (refer to Page 21).
Excessive vibration from saw.	<ol style="list-style-type: none"> 1. Machine mounting fasteners loose. 2. Unsuitable mounting surface. 3. Loose motor mounts. 	<ol style="list-style-type: none"> 1. Inspect/re-tighten/replace. 2. The more solid the mounting surface is, the less vibration will be felt (solid wood is better than plywood). 3. Inspect/re-tighten/repair.
Blade will not stay on layout line.	<ol style="list-style-type: none"> 1. Blade not tensioned correctly. 2. Too much pressure applied to the workpiece. 3. Blade holders not aligned correctly. 	<ol style="list-style-type: none"> 1. Properly tension the blade (refer to Page 17). 2. Reduce the feed rate and pressure on the workpiece. 3. Re-adjust the blade holders so that are aligned in a straight line with the saw.
Excessive blade breakage.	<ol style="list-style-type: none"> 1. Blade not tensioned correctly. 2. Not using relief cuts when cutting tight curves; twisting blade. 3. Wrong blade for the operation. 4. Too much pressure on the blade. 5. Not enough blade teeth per inch. 	<ol style="list-style-type: none"> 1. Properly tension the blade (refer to Page 17). 2. Use more relief cuts for tight turns; reduce feed rate; do not twist the blade—allow the blade to do the work. 3. Refer to the Blade Selection Chart on Page 18 and use the right blade for the operation. 4. Reduce the pressure on the workpiece as it passes through the blade. 5. The blade should have at least 3 teeth in contact with the workpiece at all times during operation.

PARTS

Main

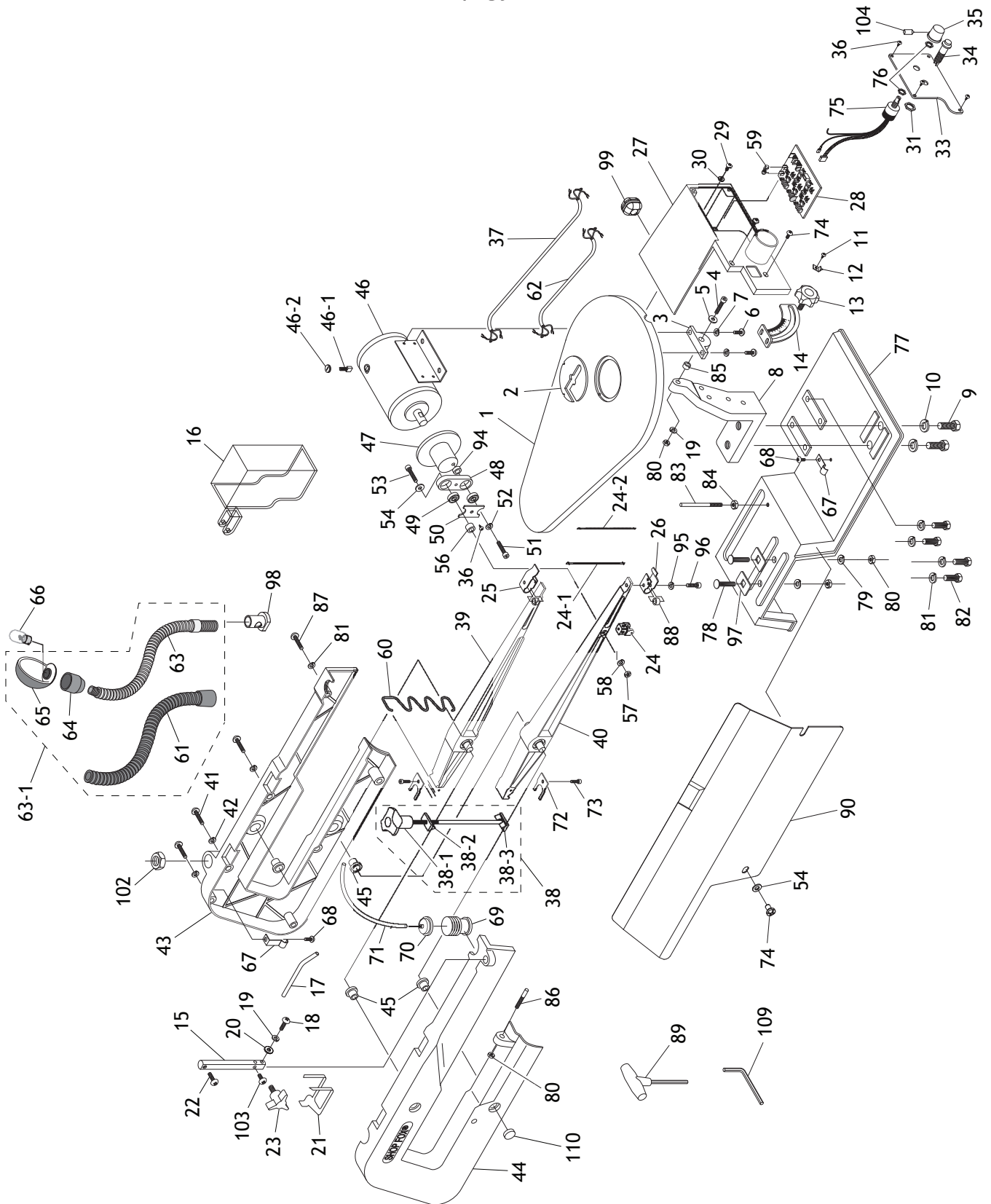

Main Parts List

REF	PART #	DESCRIPTION
1	X1713001	TABLE
2	X1713002	TABLE INSERT
3	X1713003	TABLE PIVOT BRACKET
4	XPCAP48M	CAP SCREW M6-1 X 35
5	XPW03M	FLAT WASHER 6MM
6	XPS09M	PHLP HD SCR M5-.8 x 10
7	XPLW01M	LOCK WASHER 5MM
8	X1713008	TABLE PEDESTAL
9	XPB07M	HEX BOLT M8-1.25 X 25
10	XPLW04M	LOCK WASHER 8MM
11	XPS65M	PHLP HD SCR M4-.7 X 40
12	X1713012	SCALE INDICATOR
13	X1713013	KNOB BOLT M6-1 X 14
14	X1713014	GRADUATED SCALE 0-45 DEGREES
15	X1713015	AIR HOSE POST
16	X1713016	BLADE GUARD
17	X1713017	AIR HOSE
18	XPS81M	PHLP HD SCR M6-1 X 40
19	XPLW03M	LOCK WASHER 6MM
20	XPW03M	FLAT WASHER 6MM
21	X1713021	HOLDDOWN SHOE
22	XPS09M	PHLP HD SCR M5-.8 x 10
23	X1713023	KNOB BOLT M6-1 X 13
24	X1713024	BLADE ADAPTER
24-1	X1713024-1	BLADE 18TPI
24-2	X1713024-2	BLADE 15TPI
25	X1713025	UPPER BLADE HOLDER
26	X1713026	LOWER BLADE HOLDER
27	X1713027	SWITCH BOX HOUSING
28	X1713028	CIRCUIT BOARD
29	XPS02M	PHLP HD SCR M4-.7 X 12
30	XPW05M	FLAT WASHER 4MM
31	X1713031	THIN PROFILE HEX NUT M12-1.75
33	X1713033	SWITCH BOX COVER
34	X1713034	LIGHT SWITCH
35	X1713035	SPEED CONTROL DIAL
36	XPHTEK7	TAP SCREW #8 X 3/8
37	X1713037	POWER CORD
38	X1713038	BLADE TENSION ASSEMBLY
38-1	X1713038-1	BLADE TENSION BODY
38-2	X1713038-2	THREADED PLATE
38-3	X1713038-3	NON-THREADED PLATE
39	X1713039	UPPER ARM
40	X1713040	LOWER ARM
41	XPS75M	PHLP HD SCR M5-.8 X 35
42	XPLW01M	LOCK WASHER 5MM
43	X1713043	RIGHT ARM COVER
44	X1713044	LEFT ARM COVER
45	X1713045	BUSHING 3/8"
46	X1713046	MOTOR 1/8HP 110V 60HZ
46-1	X1713046-1	CARBON BRUSH
46-2	X1713046-2	CARBON BRUSH CAP
47	X1713047	FLYWHEEL
48	X1713048	BEARING HOUSING

REF	PART #	DESCRIPTION
49	XP625ZZ	BALL BEARING 625ZZ
50	X1713050	BEARING RETAINER
51	XPCAP24M	CAP SCREW M5-.8 X 16
52	XPLW01M	LOCK WASHER 5MM
53	XPCAP38M	CAP SCREW M5-.8 X 25
54	XPW02M	FLAT WASHER 5MM
56	X1713056	SPACER 5 X 6MM
57	XPNO6M	HEX NUT M5-.8
58	XPLW01M	LOCK WASHER 5MM
59	X1713059	FUSE 6A
60	X1713060	BLADE TENSION SPRING
61	X1713061	FLEXIBLE LAMP NECK GUARD
62	X1713062	MOTOR CORD
63	X1713063	FLEXIBLE LAMP NECK
63-1	X1713063-1	FLEX NECK/HOUSING ASSEMBLY
64	X1713064	LAMP SOCKET
65	X1713065	LAMP HOOD
66	X1713066	LIGHT BULB 120V/10W
67	X1713067	CORD CLAMP
68	XPS07M	PHLP HD SCR M4-.7 X 8
69	X1713069	BELLOWS
70	X1713070	BELLOWS LOCK
71	X1713071	PVC TUBE
72	X1713072	FORKED RETAINER
73	XPCAP17M	CAP SCREW M4-.7 X 10
74	XPS05M	PHLP HD SCR M5-.8 X 8
75	X1713075	VARIABLE SPEED SWITCH
76	X1713076	THIN PROFILE HEX NUT 10MM
77	X1713077	BASE
78	XPCB13M	CARRIAGE BOLT M6-1 X 20
79	XPLW03M	LOCK WASHER 6MM
80	XPNO1M	HEX NUT M6-1
81	XPLW03M	LOCK WASHER 6MM
82	XPB08M	HEX BOLT M6-1 X 20
83	X1713083	STUD BOLT M6-1X 95
84	XPNO1M	HEX NUT M6-1
85	X1713085	SPACER
86	X1713086	STUD BOLT HINGE PIN M6-1 X 18
87	XPS62M	PHLP HD SCR M6-1 X 30
88	X1713088	BLADE GUIDE SPACER
89	X1713089	T-HANDLE HEX WRENCH 3MM
90	X1713090	BASE COVER
94	X1713094	SPACER
95	XPLW02M	LOCK WASHER 4MM
96	XPCAP39M	CAP SCREW M4-.7 X 20
97	X1713097	CLAMP PLATE
98	X1713098	LAMP NECK BASE
99	X1713099	STRAIN RELIEF
102	X1713102	LAMP NECK BASE HEX NUT
103	XPS19M	PHLP HD SCR M5-.8 X 6
104	XPSS26M	SET SCREW M5-.8 X 6
109	XPAW04M	HEX WRENCH 4MM
110	X17131110	BEARING CAPS

Machine Labels

! WARNING

Safety labels warn about machine hazards and how to prevent machine damage or injury. The owner of this machine **MUST** maintain the original location and readability of all labels on this machine. If any label is removed or becomes unreadable, **REPLACE** that label before allowing the machine to enter service again. Contact Woodstock International, Inc. at (360) 734-3482 or www.shopfoxtools.com to order new labels.

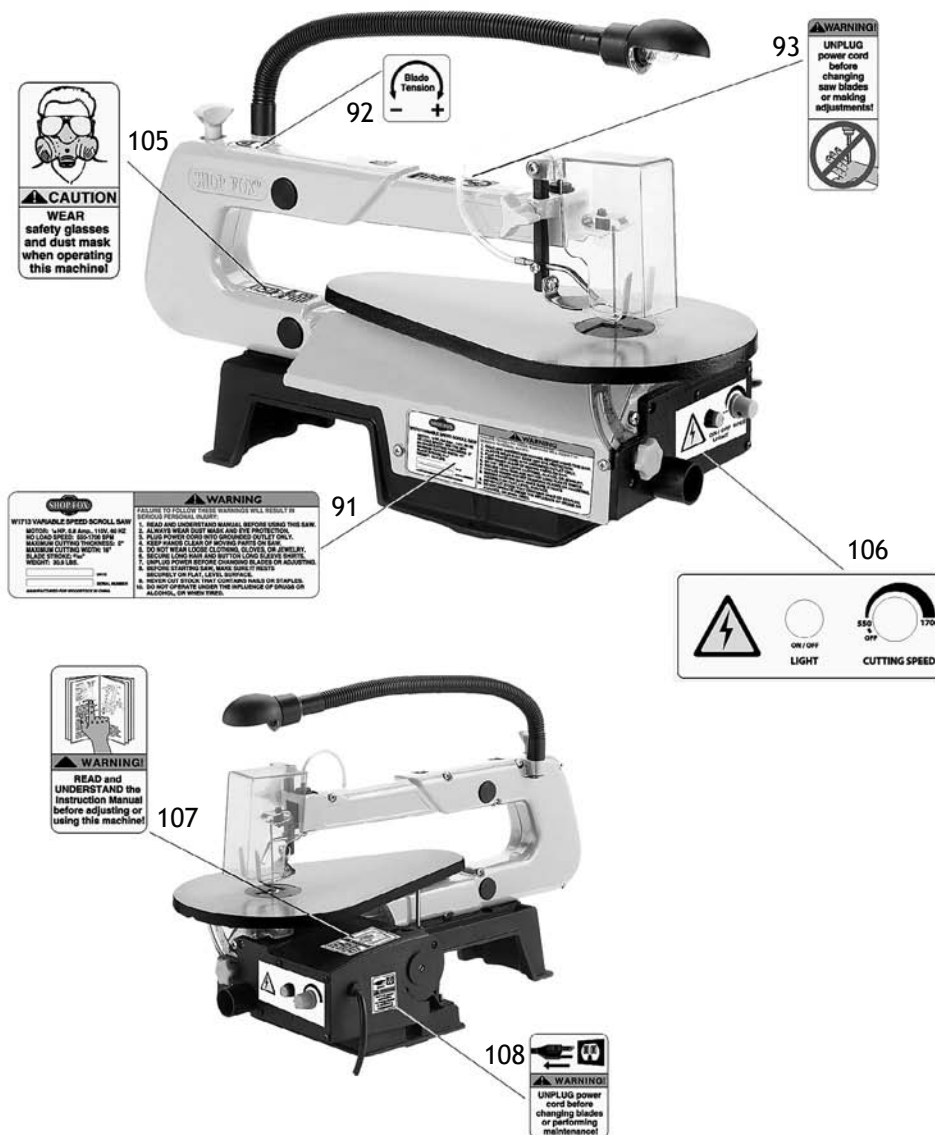

REF	PART #	DESCRIPTION
91	X1713091	MACHINE ID LABEL
92	X1713092	BLADE TENSION LABEL
93	X1713093	UNPLUG POWER CORD LABEL
105	X1713105	EYE/LUNG CAUTION LABEL

REF	PART #	DESCRIPTION
106	X1713106	CONTROL PANEL LABEL
107	XLABEL-12	READ MANUAL LABEL
108	X1713108	DISCONNECT POWER LABEL

PARTS

Notes



Warranty Registration

Name _____
 Street _____
 City _____ State _____ Zip _____
 Phone # _____ Email _____ Invoice # _____
 Model # _____ Serial # _____ Dealer Name _____ Purchase Date _____

The following information is given on a voluntary basis. It will be used for marketing purposes to help us develop better products and services. *Of course, all information is strictly confidential.*

1. How did you learn about us?

<input type="checkbox"/> Advertisement	<input type="checkbox"/> Friend	<input type="checkbox"/> Local Store
<input type="checkbox"/> Mail Order Catalog	<input type="checkbox"/> Website	<input type="checkbox"/> Other:

2. How long have you been a woodworker/metalworker?

<input type="checkbox"/> 0-2 Years	<input type="checkbox"/> 2-8 Years	<input type="checkbox"/> 8-20 Years	<input type="checkbox"/> 20+ Years
------------------------------------	------------------------------------	-------------------------------------	------------------------------------

3. How many of your machines or tools are Shop Fox?

<input type="checkbox"/> 0-2	<input type="checkbox"/> 3-5	<input type="checkbox"/> 6-9	<input type="checkbox"/> 10+
------------------------------	------------------------------	------------------------------	------------------------------

4. Do you think your machine represents a good value? Yes No

5. Would you recommend Shop Fox products to a friend? Yes No

6. What is your age group?

<input type="checkbox"/> 20-29	<input type="checkbox"/> 30-39	<input type="checkbox"/> 40-49
<input type="checkbox"/> 50-59	<input type="checkbox"/> 60-69	<input type="checkbox"/> 70+

7. What is your annual household income?

<input type="checkbox"/> \$20,000-\$29,000	<input type="checkbox"/> \$30,000-\$39,000	<input type="checkbox"/> \$40,000-\$49,000
<input type="checkbox"/> \$50,000-\$59,000	<input type="checkbox"/> \$60,000-\$69,000	<input type="checkbox"/> \$70,000+

8. Which of the following magazines do you subscribe to?

<input type="checkbox"/> Cabinet Maker	<input type="checkbox"/> Popular Mechanics	<input type="checkbox"/> Today's Homeowner
<input type="checkbox"/> Family Handyman	<input type="checkbox"/> Popular Science	<input type="checkbox"/> Wood
<input type="checkbox"/> Hand Loader	<input type="checkbox"/> Popular Woodworking	<input type="checkbox"/> Wooden Boat
<input type="checkbox"/> Handy	<input type="checkbox"/> Practical Homeowner	<input type="checkbox"/> Woodshop News
<input type="checkbox"/> Home Shop Machinist	<input type="checkbox"/> Precision Shooter	<input type="checkbox"/> Woodsmith
<input type="checkbox"/> Journal of Light Cont.	<input type="checkbox"/> Projects in Metal	<input type="checkbox"/> Woodwork
<input type="checkbox"/> Live Steam	<input type="checkbox"/> RC Modeler	<input type="checkbox"/> Woodworker West
<input type="checkbox"/> Model Airplane News	<input type="checkbox"/> Rifle	<input type="checkbox"/> Woodworker's Journal
<input type="checkbox"/> Modeltec	<input type="checkbox"/> Shop Notes	<input type="checkbox"/> Other:
<input type="checkbox"/> Old House Journal	<input type="checkbox"/> Shotgun News	

9. Comments: _____

CUT ALONG DOTTED LINE

FOLD ALONG DOTTED LINE

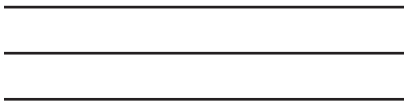

Place
Stamp
Here



WOODSTOCK INTERNATIONAL INC.
P.O. BOX 2309
BELLINGHAM, WA 98227-2309



FOLD ALONG DOTTED LINE

TAPE ALONG EDGES--PLEASE DO NOT STAPLE

WARRANTY

Woodstock International, Inc. warrants all Shop Fox machinery to be free of defects from workmanship and materials for a period of two years from the date of original purchase by the original owner. This warranty does not apply to defects due directly or indirectly to misuse, abuse, negligence or accidents, lack of maintenance, or reimbursement of third party expenses incurred.

Woodstock International, Inc. will repair or replace, at its expense and at its option, the Shop Fox machine or machine part, which in normal use has proven to be defective, provided that the original owner returns the product prepaid to a Shop Fox factory service center with proof of their purchase of the product within two years, and provides Woodstock International, Inc. reasonable opportunity to verify the alleged defect through inspection. If it is determined there is no defect, or that the defect resulted from causes not within the scope of Woodstock International Inc.'s warranty, then the original owner must bear the cost of storing and returning the product.

This is Woodstock International, Inc.'s sole written warranty and any and all warranties that may be implied by law, including any merchantability or fitness, for any particular purpose, are hereby limited to the duration of this written warranty. We do not warrant that Shop Fox machinery complies with the provisions of any law or acts. In no event shall Woodstock International, Inc.'s liability under this warranty exceed the purchase price paid for the product, and any legal actions brought against Woodstock International, Inc. shall be tried in the State of Washington, County of Whatcom. We shall in no event be liable for death, injuries to persons or property or for incidental, contingent, special or consequential damages arising from the use of our products.

Every effort has been made to ensure that all Shop Fox machinery meets high quality and durability standards. We reserve the right to change specifications at any time because of our commitment to continuously improve the quality of our products.



High Quality Machines and Tools

Woodstock International, Inc. carries thousands of products designed to meet the needs of today's woodworkers and metalworkers. Ask your dealer about these fine products:

BROSENA
PRECISION STOP BLOCK

JOINTER PAL[®]

Rotacator[®]

THE REBEL[®]

DURASTICK[®]

Gutmann[®]

BOARD BUDDIES[®]



Junglee[®]

PLANER PAL[®]

PARROT VISE[®]

SLICKPLANE[®]

PRO-STIK[®]
ABRASIVE BELT & DISC CLEANER

ACCU-SHARP[®]

Aluma-Classic[®]



STEELEX[®]
FINE TOOLS

STEELEX[®]
PLUS



WHOLESALE ONLY

WOODSTOCK INTERNATIONAL, INC.

Phone: (360) 734-3482 • Fax: (360) 671-3053 • Toll Free Fax: (800) 647-8801

P.O.Box 2309 • Bellingham, WA 98227

SHOPFOX.BIZ

Free Manuals Download Website

<http://myh66.com>

<http://usermanuals.us>

<http://www.somanuals.com>

<http://www.4manuals.cc>

<http://www.manual-lib.com>

<http://www.404manual.com>

<http://www.luxmanual.com>

<http://aubethermostatmanual.com>

Golf course search by state

<http://golfingnear.com>

Email search by domain

<http://emailbydomain.com>

Auto manuals search

<http://auto.somanuals.com>

TV manuals search

<http://tv.somanuals.com>