

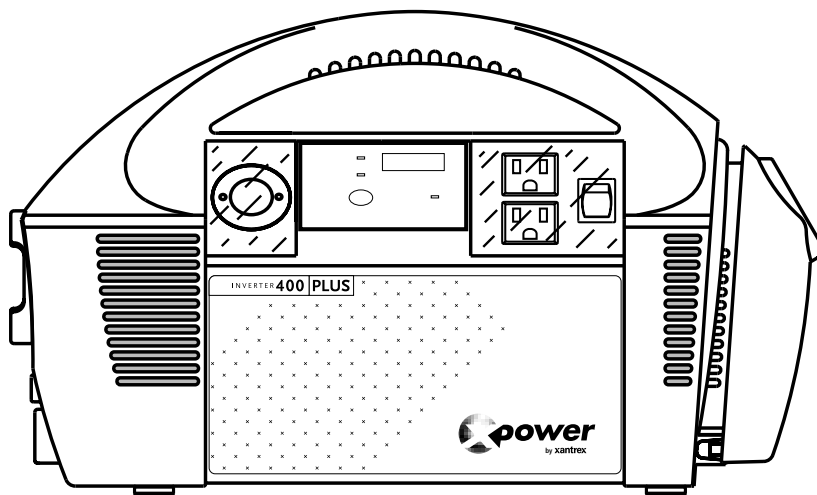

# XPower Powerpack 400 PLUS and 400R



## Owner's Guide

## About Xantrex

Xantrex Technology Inc. is a world-leading supplier of advanced power electronics and controls with products from 50 watt mobile units to one MW utility-scale systems for wind, solar, batteries, fuel cells, microturbines, and backup power applications in both grid-connected and stand-alone systems. Xantrex products include inverters, battery chargers, programmable power supplies, and variable speed drives that convert, supply, control, clean, and distribute electrical power.

## Trademarks

XPower is a trademark of Xantrex International. Xantrex is a registered trademark of Xantrex International.

Other trademarks, registered trademarks, and product names are the property of their respective owners and are used herein for identification purposes only.

## Notice of Copyright

Xpower™ Powerpack 400 Plus and 400R Owner's Guide  
© July 2004 Xantrex International. All rights reserved.

## Disclaimer

UNLESS SPECIFICALLY AGREED TO IN WRITING, XANTREX TECHNOLOGY INC.  
("XANTREX")

(a) MAKES NO WARRANTY AS TO THE ACCURACY, SUFFICIENCY OR SUITABILITY OF ANY TECHNICAL OR OTHER INFORMATION PROVIDED IN ITS MANUALS OR OTHER DOCUMENTATION.

(b) ASSUMES NO RESPONSIBILITY OR LIABILITY FOR LOSS OR DAMAGE, WHETHER DIRECT, INDIRECT, CONSEQUENTIAL OR INCIDENTAL, WHICH MIGHT ARISE OUT OF THE USE OF SUCH INFORMATION. THE USE OF ANY SUCH INFORMATION WILL BE ENTIRELY AT THE USER'S RISK.

## Date and Revision

July 2004 Revision A

## Part Number

975-0162-01-01

## Contact Information

Telephone: 1-800-394-0440 (toll free in North America)

1-360-925-5097 (direct)

Fax: 1-800-994-7828 (toll free in North America)

1-360-925-5143 (direct)

Email: [CustomerService@xantrex.com](mailto:CustomerService@xantrex.com)

Web: [www.xantrex.com](http://www.xantrex.com)

# About This Guide

## Purpose

The purpose of this Owner's Guide is to provide explanations and procedures for installing, operating, maintaining, and troubleshooting the XPower Powerpack 400 Plus and XPower Powerpack 400R.

The Guide provides safety guidelines, detailed planning and setup information, as well as information about operating and troubleshooting the unit.

## Conventions Used

The following conventions are used in this guide.



### **WARNING**

Warnings identify conditions that could result in personal injury or loss of life.

---



### **CAUTION**

Cautions identify conditions or practices that could result in damage to the product or to other equipment.

---

---

**Important:** These notes describe an important action item or an item that you must pay attention to.

---

**Note:** These notes describe additional information which may add to your understanding of how to use the product.

---

## References to XPower Powerpack

In this guide, both the **XPower Powerpack 400 Plus** and the **XPower Powerpack 400R** (with radio and air compressor) are referred to as **XPower Powerpack** when the information applies to both models. However, when the information is specific to one model, then reference is made specifically to the **XPower Powerpack 400 Plus** or to the **XPower Powerpack 400R**.

## Related Information

You can find more information about Xantrex Technology Inc. as well as its products and services at [www.xantrex.com](http://www.xantrex.com)

# Important Safety Instructions

The XPower Powerpack 400 Plus and XPower Powerpack 400R generate a type of AC power similar to a normal household wall outlet. Operating the XPower Powerpack incorrectly or misusing it may damage the equipment or create hazardous conditions for the user.

---

**Important:** Before using your XPower Powerpack 400 Plus and XPower Powerpack 400R, be sure to read and save these safety instructions.

---

## Warnings and Cautions



**WARNING: Shock hazard. Keep away from children.**

The XPower Powerpack generates the same potentially lethal AC power as a normal household wall outlet. Do not insert foreign objects into the AC Outlet, the DC Power Socket, the Jump-Start Cable Port, or the ventilation holes. Do not expose this product to water, rain, snow, or spray.

Do not open the XPower Powerpack except to replace the internal battery. Have a qualified technician complete any service work.



**CAUTION**

Do not connect any AC appliance with the neutral conductor connected to ground to the XPower Powerpack.



### **CAUTION**

Do not expose the XPower Powerpack to temperatures over 104 °F (40 °C).

---



### **WARNING: Explosion hazard**

Do not use this product where there are flammable fumes or gases, such as in the bilge of a gasoline- powered boat, or near propane tanks. Do not use this product in an enclosure containing automotive-type lead acid batteries. These batteries, unlike the sealed AGM battery in XPower Powerpack, vent explosive hydrogen gas which can be ignited by sparks from electrical connections.

When working on electrical equipment, always ensure someone is nearby to help you in an emergency.

---



### **WARNING: Heated surface**

Ensure at least 2" (5 cm) air space is maintained on all sides of the XPower Powerpack. During operation, keep away from materials that may be affected by high temperatures such as blankets, pillows and sleeping bags.

---



### **WARNING: Fire hazard**

Never allow jump-start cables' red and black clamps to touch each other or another common metal conductor. This could cause damage to the unit and/or create a sparking/explosion hazard. Always disconnect the jump-start cables from the unit after use and clip the plastic guard over the jump-start cable port.

---



### **WARNING: Fire hazard**

Jump-start cable clamps must be connected positive to positive (red clamp to battery "+") and negative to negative (black clamp to battery "-"). A reverse polarity connection (positive to negative) may cause damage to the unit and/or create a sparking/explosion hazard.

---



**WARNING: Fire hazard**

The jump-start feature is designed for short term operation only—less than 4 seconds. Operating the jump-start feature for more than 4 seconds may cause damage to the unit. Allow the XPower Powerpack to cool down for at least 3 minutes after each jump-start.

---



**WARNING: Risk of explosion, fire or burns**

The battery terminals exposed at the Jump-Start Cable Port have enough energy present to cause a spark, creating an explosion hazard, or to cause burns if a metal object contacts both terminals. Always clip the plastic guard over the Port when not in use.

---



**WARNING: Fire hazard**

Do not leave the compressor unattended while operating. The compressor is designed for short term operation only. Operation of the compressor over an extended period of time will cause the compressor unit to overheat and may cause damage. Allow the compressor to cool down for 10 minutes after each 10 minutes of continuous operation.

---

## Precautions When Working With Batteries



---

### **WARNING: Explosion and fire hazard**

---

1. Follow all instructions published by the battery manufacturer and the manufacturer of the equipment in which the battery is installed.
2. Make sure the area around the battery is well-ventilated.
3. Never smoke or allow a spark or flame in vicinity of the engine or batteries.
4. Be careful not to drop a metal object on the battery or allow a metal tool to simultaneously touch the positive and negative cable ends or battery terminals. It might spark or short-circuit the battery or other electrical parts and cause an explosion.
5. Remove personal metal items such as rings, bracelets, necklaces, and watches when working with a lead-acid battery. A lead-acid battery produces a short-circuit current high enough to weld a ring or other similar objects to metal, causing a severe burn.
6. If you need to remove a battery, always remove the positive terminal from the battery first. Make sure all accessories are off so you don't cause an arc.
7. Someone should be within range of your voice, or close enough to come to your aid when you work near a lead-acid battery.
8. Have plenty of fresh water and soap nearby in case battery acid contacts skin, clothing, and eyes.
9. Wear complete eye protection and clothing protection. Avoid touching your eyes while working near batteries.



10. If battery acid contacts skin or clothing, wash immediately with soap and water. If acid enters your eyes, immediately flood them with running cold water for at least twenty minutes and get medical attention immediately.
11. Keep a supply of baking soda on hand in the area of the batteries. Baking soda neutralizes lead-acid battery electrolyte.

# Precautions for Using Rechargeable Appliances



## CAUTION

The output of the inverter is non-sinusoidal.

---

Most rechargeable battery-operated equipment uses a separate charger or transformer that is plugged into an AC receptacle and produces a low voltage charging output.

Some chargers for rechargeable batteries can be damaged if connected to the XPower Powerpack 400 Plus and XPower Powerpack 400R.

Do not use the following with the XPower Powerpack 400 Plus and XPower Powerpack 400R:

- Small battery-operated appliances like flashlights, razors, and night lights that can be plugged directly into an AC receptacle to recharge.
- Some chargers for battery packs used in hand power tools. These affected chargers display a warning label stating that dangerous voltages are present at the battery terminals.

---

**Note:** If you are unsure about using your rechargeable appliance with the XPower Powerpack, contact the equipment manufacturer to determine the rechargeable appliance's compatibility with the modified sine wave (non-sinusoidal) AC waveform.

---

# Contents

## Important Safety Instructions

Warnings and Cautions - - - - -	iii
Precautions When Working With Batteries - - - - -	vi
Precautions for Using Rechargeable Appliances - - - - -	viii

## 1 Introduction

About the XPower Powerpack - - - - -	1-1
Comprehensive Protection - - - - -	1-1
Automatic overload - - - - -	1-1
Overheating - - - - -	1-2
Low Battery Protection - - - - -	1-2
Jump-Start Cables Safety Feature - - - - -	1-2

## 2 Features

Materials List - - - - -	2-1
XPower Powerpack Features - - - - -	2-2
Front Panel Detail - - - - -	2-2
Rear Panel Detail (XPower Powerpack 400R only) - - - - -	2-5
Air Compressor - - - - -	2-7
Left Side View - - - - -	2-8
Storage Compartment - - - - -	2-9
Accessories - - - - -	2-10

---

## 3 Operation

Operating Conditions and Guidelines	3-1
Choosing a Location	3-2
Using XPower Powerpack for the First Time	3-3
Recharging with the AC Charger	3-3
Using the light	3-4
Operating AC Appliances	3-4
Understanding AC Appliances	3-4
Run Time on Typical AC Appliances	3-5
High Surge Appliances	3-5
Trouble Appliances	3-6
Operating Several Appliances at Once	3-6
Operating an AC Appliance	3-6
Operating 12 V DC Appliances	3-8
Jump-Starting a Vehicle's Engine	3-10
Using the Air Compressor	3-12
Over-Temperature Safety Protection	3-12
Inflating Tires	3-13
Inflating Small Sports Equipment	3-14
Using the Radio: XPower Powerpack 400R	3-15
Power Draw	3-16
Listening to the AM Band	3-16
Connecting to an External Battery	3-16

## 4 Maintenance

Battery Maintenance	4-1
Recharging the XPower Powerpack Battery	4-2
Recharging with the AC Charger	4-2
Recharging with the DC Charging Cable	4-3
Recharging with a Generator's Regulated 12 V DC Outlet	4-5
Recharging From a Solar Panel	4-6
Replacing the Internal Battery	4-6
Battery Life	4-6

---

Obtaining a Replacement Battery - - - - -	4-7
Replacing the Battery - - - - -	4-7
Replacing the Incandescent Light - - - - -	4-9
Replacing the External Fuse - - - - -	4-10

## 5 Troubleshooting

Common Problems - - - - -	5-1
Buzz in Audio Equipment - - - - -	5-1
Television Interference - - - - -	5-1
Troubleshooting Reference - - - - -	5-2

## A Specifications

Electrical Specifications - - - - -	A-1
Physical Specifications - - - - -	A-3

## B Warranty and Product Information

Warranty - - - - -	B-2
Return Material Authorization Policy - - - - -	B-5
Out of Warranty Service - - - - -	B-7
Information About Your System - - - - -	B-8



# 1 Introduction

## About the XPower Powerpack

Easy-to-use and designed for years of reliable service, the XPower Powerpack can run many AC appliances and 12 V DC appliances whenever you need power for work or play, at home or on the road.

XPower Powerpack:

- Powers 115 V AC appliances
- Powers 12 V DC appliances
- Jump-starts vehicle engines
- Provides lighting for emergency use
- Inflates tires and small sports equipment with a 250 psi air compressor.

In addition, the XPower Powerpack 400R comes with:

- An AM/FM radio with digital alarm clock.

## Comprehensive Protection

### Automatic overload

The XPower Powerpack has built-in protection against output overload. If you connect to the AC Outlet(s) an appliance that draws more than 320 W, or one which draws excessive surge power, the power to the AC Outlet automatically shuts off.

## Overheating

The XPower Powerpack is protected from overheating. If the inverter exceeds a safe temperature, power to the AC Outlet automatically shuts off.

## Low Battery Protection

Low battery protection protects the internal battery from excessive discharge and possible damage. When the AC Outlet ON/OFF switch is turned on, an audible alarm alerts you when the internal battery is nearly discharged (11.0 V DC) and the unit turns off at 10.5 V DC.

## Jump-Start Cables Safety Feature

The XPower Powerpack comes with a user-replaceable 250 A fuse to protect the unit and vehicle battery from damage through reverse polarity and short-circuit conditions.



# 2 Features

Chapter 2 describes the main features of the XPower Powerpack. We recommend that you familiarize yourself with these features before operating the unit.

## Materials List

Your XPower Powerpack package includes these items:

- XPower Powerpack 400 Plus or XPower Powerpack 400R
- Owner's Guide
- AC charger
- DC charging cable
- Jump-start cables
- Accessory bag
- Two nozzle adaptors for the compressor
- One sports needle adaptor for the compressor.

The XPower Powerpack 400R also includes:

- Red "emergency" light cover.

If any of these materials are missing or are unsatisfactory in any way, please contact Customer Service, see Appendix B.

# XPower Powerpack Features

## Front Panel Detail

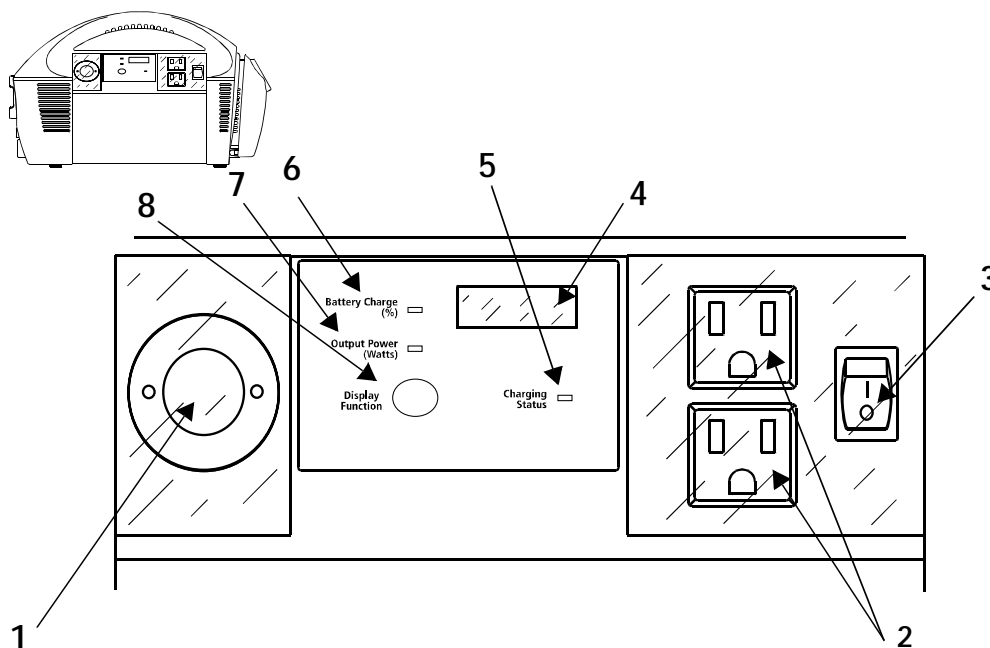

### XPower Powerpack Features

Feature	Description
1	<b>DC Power Socket</b> can: <ul style="list-style-type: none"> <li>• Power 12 V DC auto, RV or marine appliances</li> <li>• Recharge XPower Powerpack from a 12 V outlet in a vehicle using the DC Charging Cable.</li> </ul>
2	2 <b>AC Outlets</b> are standard 3-prong outlets supplying 120 V AC power for running an AC appliance.
3	<b>AC Outlet ON/OFF switch</b> illuminates when the switch is turned on.
4	<b>Digital Display</b> displays the inverter's <b>Output Power</b> in <b>W</b> and <b>Battery Charge</b> status in <b>% FULL</b> .

Feature	Description
5	<b>Charging Status</b> light illuminates when the XPower Powerpack is in <b>Charging Status</b> mode (i.e. <b>AC Charger</b> is connected to the inverter's <b>Charger Input Socket</b> and plugged into the household 120 V AC outlet).
6	<b>Battery Charge %</b> light illuminates (green) when <b>Battery Charge</b> information is displayed on the <b>Digital Display</b> .
7	<b>Output Power (W)</b> light illuminates (green) when <b>Output Power</b> information is displayed on the <b>Digital Display</b> .
8	<b>Display Function</b> button, when pressed, allows for reading <b>Battery Charge</b> status on the <b>Digital Display</b> . Toggles <b>Digital Display's</b> power ON/OFF.
Not shown	<b>Audible Alarm</b> (inside the unit) sounds in the event of overheating or low battery protection on inverter.

### Control Panel Operation

How to...	Required Condition	Required Action	Note
Monitor total AC power consumed by the applications powered from the Powerpack's 2 AC outlets	Inverter's ON/OFF switch is turned ON; <b>Output Power (W)</b> light illuminates (green); AC charger is unplugged from the wall AC outlet.	No action required. The Digital Display will show the AC power drawn from the inverter by the applications powered from the Powerpack's AC outlets.	In order to save the battery power and ensure longer inverter run time, press <b>Display Function</b> button to turn off the Digital Display. Press <b>Display Function</b> button again to turn the display on for AC power reading.

## Features

How to...	Required Condition	Required Action	Note
Monitor Battery Charging status	<p>Inverter's ON/OFF switch is turned to OFF;</p> <p>All appliances must be disconnected from the AC and DC power outlets;</p> <p>The ON/OFF switch of the incandescent light must be turned to OFF;</p> <p>The AC charger must be plugged into the Powerpack's Charger Input Socket and also in to a household AC outlet.</p>	<p>No action required.</p> <p>A flashing green <b>Charging Status</b> light indicates that the Powerpack's battery needs recharging and that the AC charger is charging the battery.</p> <p>A steady green <b>Charging Status</b> light indicates that the Powerpack's battery is fully charged and the Powerpack is ready for use.</p>	<p>Recharging with the supplied AC charger is a true "plug-in-and-forget" charging method.</p> <p>We recommend leaving the AC charger connected when the Powerpack is not in use to permanently maintain the battery in fully charged condition.</p>
Check Battery Charge status	<p>Inverter's ON/OFF switch is turned to OFF;</p> <p>All appliances must be disconnected from the AC and DC power outlets;</p> <p>The ON/OFF switch of the incandescent light must be turned to OFF;</p> <p>The AC charger must <b>not</b> be plugged into the Powerpack's Charger Input Socket.</p>	<p>Push and hold the <b>Display Function</b> button.</p> <p>The green <b>Battery Charge (%)</b> light will come on and the Digital Display will show the remaining battery capacity in %.</p>	<p>This function is disabled when the AC charger is plugged in to the Charger Input Socket, or when the inverter main switch is ON.</p> <p>For accurate Battery Charge reading, allow 15 minutes between charging/use and battery capacity check.</p>

## Rear Panel Detail (XPower Powerpack 400R only)

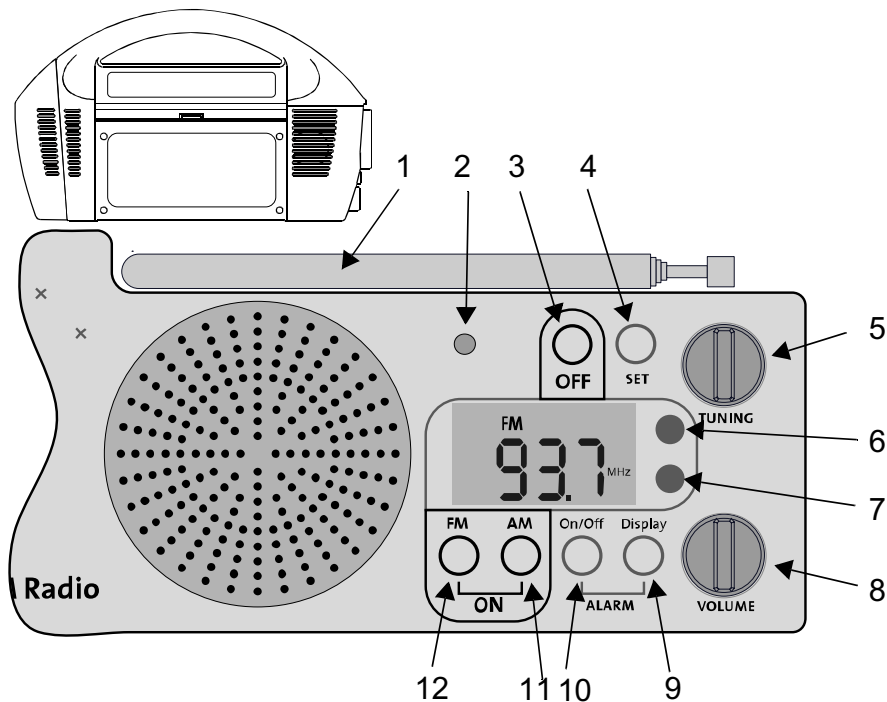

Feature	Description
1	FM antenna
2	Frequency indicator light
3	Power OFF button
4	Time set button
5	Tuning dial
6	Hours set button
7	Minutes set button
8	Volume dial
9	Alarm set button
10	Alarm clock ON/OFF button
11	AM band button/ON
12	FM band button/ON

## Radio Operation

How to...	Required Condition	Required Action	Note
Listen to the radio		Press the AM band button (11) or the FM band button (12). To turn off the radio, press the power OFF button (3).	When radio is on, the station frequency is displayed. When radio is off, the time is displayed.
Set the clock	Turn off the radio to show the time.	To adjust hour, press and hold Time Set button (4), and press hours set button (6). To adjust minutes, press and hold (4), and press minutes set button (7).	The clock uses a 12-hour (AM/PM) time format.
Set the alarm	Turn off the radio to show the time.	To adjust hour, press and hold Alarm Set button (9), and press hours set button (6). To adjust minutes, press and hold (9), and press minutes set button (7).	The alarm clock uses a 12-hour (AM/PM) time format.
Use the alarm clock	Set the alarm, turn off radio to show time.	Press Alarm Clock ON/OFF button (10). "α" shows on the display screen.	When the alarm clock turns the radio on, the power off button (3) does not work. To turn off the radio, press Alarm Clock ON/OFF (10), then press (3).
Improve reception	Radio tuned to FM station.	Adjust the direction and length of the FM antenna.	N/A.

## Air Compressor

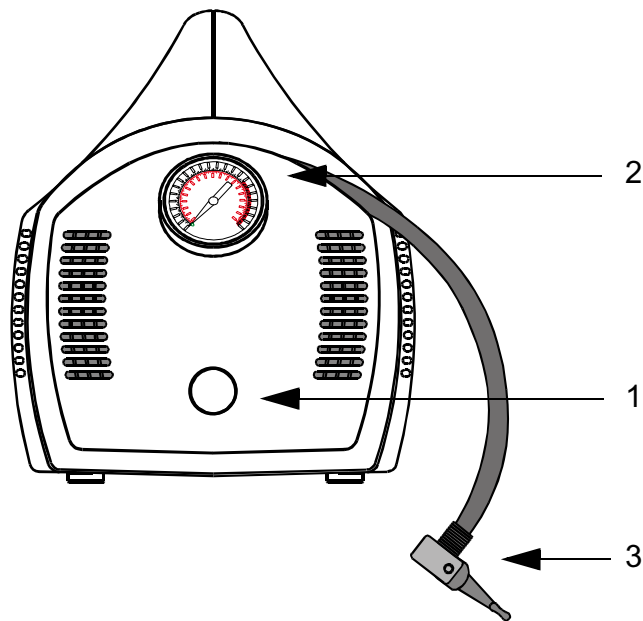

Feature	Description
1	<b>ON/OFF switch</b> turns the compressor unit on and off.
2	<b>Pressure gauge</b> shows the PSI (lb./in <sup>2</sup> )
3	<b>Valve connector with connector hose</b>

**Nozzle Adaptor Compartment** is integrated into AC charger compartment.

## Left Side View

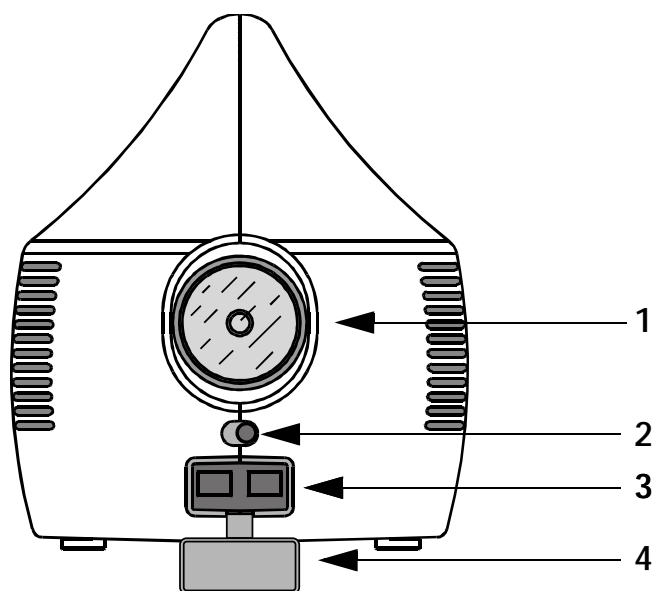

Feature	Description
1	<b>5 W incandescent light</b> illuminates for about 30 hours when the battery is fully charged.
2	<b>Light ON/OFF Switch (400 Plus)</b> <b>Light ON/OFF/Pulse Switch (400R)</b>
3	<b>Jump-Start Cable Port</b> supplies high power DC current. The cables connect to the Jump-Start Cable Port when jump-starting a vehicle's battery or when connecting an external battery to the XPower Powerpack. The jump-start cable connection is designed so that the cables cannot be inserted incorrectly into the Jump-Start Cable Port.
4	<b>Plastic Guard</b> for covering Jump-Start Cable Port.



## Storage Compartment

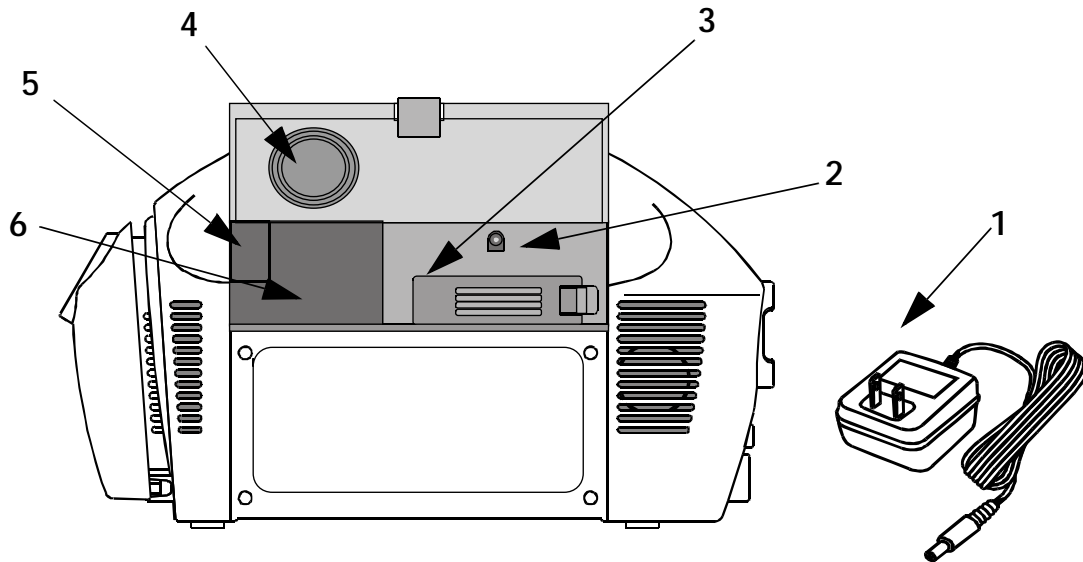

XPower Powerpack 400R shown

Feature	Description
1	<b>AC Charger</b> lets you recharge the XPower Powerpack from a standard AC wall outlet and can only be used to recharge the internal battery of the XPower Powerpack. Can be stored in AC charger compartment.
2	<b>Charger Input Socket</b> for use with the AC Charger supplied (see 1).
3	<b>External Replaceable Fuse</b> is rated at 250 A, 32 V. Located behind fuse cover.
4	<b>Red “emergency” light cover</b>
5	<b>Compressor Nozzle Adaptor Compartment</b>
6	<b>AC Charger Compartment</b> may be used for storing the AC Charger.

## Accessories

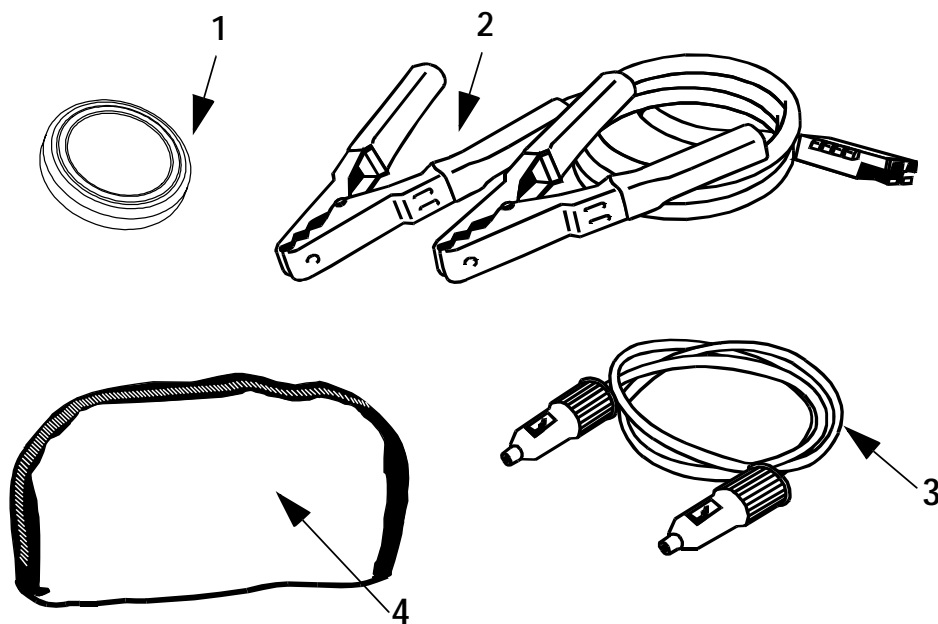

Feature	Description
1	<b>Red emergency light cover</b> stored in the rear compartment (400R only). This cover can turn the 5 W incandescent light into a red “emergency” light when placed over the existing clear lens.
2	<b>Detachable heavy-duty jump-start cables</b>
3	<b>DC Charging Cable</b> lets you recharge the XPower Powerpack from a 12 V system in a car, SUV, RV or a boat. This can be stored in the storage compartment.
4	<b>Accessory bag</b>
Not Shown	<b>Nozzle packet</b> contains two nozzle adaptors and sports needle adaptor, in the storage compartment on the back of the unit.

# 3 Operation

Chapter 3 explains how to operate the XPower Powerpack efficiently. This chapter covers:

- Recharging the XPower Powerpack for first time use
- Using the built in light
- Operating AC appliances and 12 V DC appliances
- Jump-starting a vehicle's engine
- Connecting to an external battery for additional run time
- Using the compressor.

## Operating Conditions and Guidelines



### CAUTION

Read all operating instructions before operating the XPower Powerpack.



### CAUTION

Do not use the XPower Powerpack to operate any AC appliances or 12 V DC appliances while recharging with the AC Charger. The AC Charger may fail if AC appliances or 12 V DC appliances are operated while the AC Charger is connected.



### CAUTION

The XPower Powerpack is not intended for use as a UPS (Uninterruptible Power Supply).

---

---

## Choosing a Location

---



### **WARNING: Fire or explosion**

The XPower Powerpack contains components that tend to produce arcs or sparks. To prevent fire or explosion, do not operate the XPower Powerpack in compartments containing batteries or flammable materials, or in locations that require ignition-protected equipment.

---

The XPower Powerpack should be operated only in locations that meet these requirements:

<b>Dry</b>	Do not allow water or other liquids to drop or splash on the XPower Powerpack.
<b>Cool</b>	Ambient air temperature should be between 32 and 104°F (0 and 40°C)—the cooler the better within this range.
<b>Ventilated</b>	Leave at least 2" (5 cm) clearance around the XPower Powerpack for air flow. Ensure that the ventilation openings are not obstructed.
<b>Safe</b>	Do not operate the unit in the same compartment as batteries or in any compartment capable of storing flammable liquids like gasoline.
<b>Protected from battery gases</b>	Do not operate the unit where it will be exposed to battery gases. These gases are very corrosive, and prolonged exposure will damage the XPower Powerpack.

---

# Using XPower Powerpack for the First Time

n

---

**Important:** Prior to operating your AC appliance or 12 V DC appliance, ensure that the battery of the XPower Powerpack is fully charged. If the battery has been fully discharged, recharging with the AC Charger may take up to 35 hours.

---

## Recharging with the AC Charger

---

**Note:** The **Battery Charge (%)** reading on the digital display is only accurate when the XPower Powerpack has been disconnected from all appliances and all charging sources for fifteen minutes.

---

Recharging with the AC Charger is a true “plug-in-and-forget” charging method. We recommend leaving the AC Charger connected when the XPower Powerpack is not in use.

**To recharge with the AC Charger:**

1. Disconnect any 12 V DC appliances and turn the light off.
2. Turn the AC Outlet ON/OFF switch to OFF.
3. Plug the AC Charger into a standard AC wall outlet.
4. Insert the AC Charger cable end into the Charger Input Socket located in the storage compartment of the unit.

The green **Charging Status** light changes from flashing to steady when charging is complete (about 35 hours if the battery is completely discharged).

---

**Important:** The 35-hour charging time for the XPower Powerpack assumes that there is 120 V at the AC wall outlet. If the voltage is less than 120 V AC, it may take more than 35 hours to fully recharge the XPower Powerpack. If, after 35 hours of charging, the green **Charging Status** light is still flashing, continue to charge the unit for another 15 hours.

---

---

**Important:** If you keep the XPower Powerpack in storage, the battery will discharge over time. Remember to recharge the battery every three months to keep the XPower Powerpack operational.

---

**Note:** Once fully charged, the charging current automatically reduces to a maintenance charge mode, and the XPower Powerpack may be left permanently connected to the AC Charger.

---

## Using the light

The XPower Powerpack has a built-in incandescent light which will operate for about 30 hours before the unit needs to be recharged.

The XPower Powerpack 400 Plus has a two-position OFF/ON switch (located beneath the light itself). The XPower Powerpack 400R has a three-position ON/OFF/Pulse switch. In the “Pulse” position, the light will flash on and off. The XPower Powerpack 400R also has a red “emergency” light cover that fits over the incandescent light for additional signalling capability.

The light can be adjusted up and down by pushing against the top or bottom of the rim around the lens.

## Operating AC Appliances

### Understanding AC Appliances

AC appliances are rated by how much electrical power (in watts) they consume. XPower Powerpack can power most appliances within its continuous power rating (320 W, 2.7 A).

Some appliances may be difficult or impossible to operate from the XPower Powerpack. They may have high surge requirements or should not be run from the XPower Powerpack. See “High Surge Appliances” on page 3–5 and “Trouble Appliances” on page 3–6.

---

## Run Time on Typical AC Appliances

**Note:** The fewer watts an AC appliance uses, the longer the XPower Powerpack will operate before recharging is required.

Typical AC appliances that can be used on the XPower Powerpack are listed in Table 3-1.

**Table 3-1** AC Appliances and Run Times

AC Appliance	Watts <sup>a</sup>	Hours <sup>b</sup>
Cordless telephone (stand by)	5	40
Home security system	5	40
Fluorescent work light	14	10
Fireplace fan	20	8
Laptop computer	25	6
Table lamp	40	3
Color TV – 13"	60	2 h 30 min.
3/8" drill	190	20 min.

a. Represents actual power consumption as measured on sample appliances.

b. Operating times assume a fully charged 20 Ah battery and may vary based on model/brand of appliance.

## High Surge Appliances

The wattage rating of AC appliances is the average power used by the appliance. Appliances such as televisions, computer monitors and appliances with motors consume much more power than their average rating when they are first switched on.

Although XPower Powerpack can supply momentary surge power up to 600 W, some appliances may exceed the capabilities of the XPower Powerpack and trigger the inverter's safety overload shutdown circuit.

---

## Trouble Appliances

---



### CAUTION

The output of the Powerpack's inverter is non-sinusoidal. Some equipment may be damaged by the inverter's modified sine wave output (non-sinusoidal).

---

Some appliances, including the types listed below, may be damaged if they are connected to the inverter:

- Electronics that modulate RF (radio frequency) signals on the AC line will not work and may be damaged.
- Speed controllers found in some fans, power tools, kitchen appliances, and other loads may be damaged.
- Some chargers for small rechargeable batteries can be damaged. See “Precautions for Using Rechargeable Appliances” on page viii for details.
- Metal halide arc (MHI) lights can be damaged.

---

**Note:** If you are unsure about powering any device with the inverter, contact the manufacturer of the device.

---

## Operating Several Appliances at Once

You can run several AC appliances if the total rating of all the appliances (in watts) does not exceed 320 W. You can run appliances using an AC power bar.

Run time, however, will decrease accordingly with the number of appliances being operated and the AC power being consumed.

## Operating an AC Appliance

Before operating your AC appliance, ensure that the battery of the XPower Powerpack is fully charged. See “Recharging with the AC Charger” on page 3–3 for details.



**To operate an AC appliance:**

1. Open the protective covering on the right side of the XPower Powerpack. Turn the AC Outlet ON/OFF switch to the ON position.

The switch illuminates to indicate AC power is available at the AC Outlets.

2. Plug the AC appliance into one of the AC Outlets and turn the appliance on. XPower Powerpack will operate most devices rated up to 320 W.
3. Recharge the XPower Powerpack as soon as possible after each use.

When using the XPower Powerpack to operate an AC appliance and the low battery warning sounds, the warning gives you time to shut your AC appliance off before loss of AC power.

If you ignore the warning, the XPower Powerpack automatically turns off a few minutes later to prevent battery damage.

In the event of an overload, low battery voltage or overheating, the XPower Powerpack automatically shuts down.

---

## Operating 12 V DC Appliances

The XPower Powerpack can operate 12 V DC auto, RV, marine, or other portable appliances that draw 12 A or less from a 12 V DC power outlet or from a vehicle's lighter socket.



### CAUTION Equipment damage

The DC Power Socket does not automatically switch off when the internal battery is discharged. To protect the internal battery against damage resulting from total discharge, We recommend that the AC Outlet On/Off switch is turned On when using the XPower Powerpack to operate a 12 V DC appliance.

Having the AC Outlet On/Off switch turned On enables the alarm to warn you when the 12 V DC appliance has nearly depleted the internal battery.

---

**Note:** The fewer watts a 12 V DC appliance draws, the longer the XPower Powerpack will operate before recharging is required.

---

Typical 12 V DC appliances that can be used on the XPower Powerpack are listed in Table 3-2.

**Table 3-2 12 V DC Appliances and Run Times**

12 V DC Appliance	Watts <sup>a</sup>	Hours <sup>b</sup>
5 W incandescent light (built into the unit)	5	30
Cellular telephone <sup>c</sup>	6	30
Portable Cooler	30	4

a. Represents actual power consumption as measured on sample appliances.

b. Operating times assume a fully charged 20 Ah battery and may vary based on model or brand of appliance.

c. Represents talks time available from 10 recharge cycles.

**To operate a 12 V DC appliance:**

1. Open the protective cover on the left side of the XPower Powerpack.
2. Plug the 12 V DC appliance into the DC power socket on the left side of the unit, and turn the 12 V DC appliance on (if required).

If the 12 V DC appliance draws more than 12 A (or has a short-circuit defect), the internal circuit breaker of the XPower Powerpack shuts off the power to the 12 V DC appliance. If this occurs, unplug the 12 V DC appliance, and the internal circuit breaker automatically resets after a few seconds.

3. Fully recharge the XPower Powerpack as soon as possible after each use.

As the DC power socket is internally wired directly to the internal battery, extended operation of a 12 V DC appliance may result in excessive battery discharge. See Caution for “Equipment damage” on page 3–8.

---

## Jump-Starting a Vehicle's Engine

You can use the XPower Powerpack to jump-start a vehicle or boat engine that has a 12 V starting battery using the supplied Jump-Start cables.



### **WARNING: Fire hazard**

Never allow cables' red and black clamps to touch each other or another common metal conductor. This could cause damage to the unit and/or create a sparking/explosion hazard. Always disconnect the clamps for the unit after use and clip the plastic guard over the jump-start cable port.



### **WARNING: Fire hazard**

Jump-start cable clamps' connection to the vehicle's battery terminals must be positive to positive (red clamp to battery "+") and negative to negative (black clamp to battery "-"). A reverse polarity connection (positive to negative) may cause damage to the unit and/or create a sparking/explosion hazard.



### **WARNING: Risk of explosion, fire or burns**

The battery terminals exposed at the Jump-Start Cable Port have enough energy present to cause a spark, creating an explosion hazard, or to cause burns if a metal object contacts both terminals. Always clip the plastic guard over the Port when not in use.

---

**Important:** Closely follow these instructions for jump-starting your vehicle as they may be different from the instructions supplied with other jump-start products or jump-start cables.

### **To jump-start a vehicle or boat engine:**

1. Turn OFF the vehicle or boat ignition and all accessories.
2. Engage the park or emergency brake and place the transmission in park for an automatic or neutral for a manual.
3. If jump-starting a boat engine, purge the engine compartment and bilge of all fumes before jump-starting.

4. Connect the cables to the Jump-Start Cable Port on the left side of the XPower Powerpack.
5. Position the XPower Powerpack on a flat, stable surface near the battery and away from all moving parts of the engine.
6. Connect the red positive (+) clip of the cables to the positive (+) terminal of the engine battery.

The battery's positive terminal is usually larger in diameter than the negative terminal. In most vehicles, the battery's positive terminal has a red wire connected to it.

7. Connect the black negative (–) clip of the cables to the engine block, cylinder head, or other stationary heavy metal part of the motor, or to the negative (–) battery terminal.

Before starting the engine, make sure the XPower Powerpack and the cables are clear of belts and fans. Do not crank the engine for more than 4 seconds.



### **WARNING: Fire hazard**

The jump-start feature is designed for short term operation only—less than 4 seconds. Operating the jump-start feature for more than 4 seconds may cause damage to the unit. Allow the XPower Powerpack to cool down for at least 3 minutes after each jump-start.

- 
8. Remove the red positive (+) clip and then the black negative (–) clip from the vehicle's battery terminal.
  9. Remove the cables from the Jump-Start Cable Port.

---

**Important:** Recharge the XPower Powerpack as soon as possible after each use. See “Recharging the XPower Powerpack Battery” on page 4–2.

---

---

## Using the Air Compressor

---



### **WARNING: Fire hazard**

The compressor is designed for short term operation only. Operating the compressor over an extended period of time will cause the compressor unit to overheat, which could lead to fire. Allow the compressor to cool down for 10 minutes after each 10 minutes of continuous operation.

---



### **WARNING: Fire hazard**

Do not leave the compressor unattended while in operation. Keep out of reach of children.

---



### **WARNING: Risk of personal injury or damage to equipment**

Never leave the compressor unattended while in operation. The compressor is capable of inflating to 250 PSI. Do not exceed the recommended pressure of either the compressor or the object being inflated. If either recommended pressure is exceeded, an explosion may result.

---

## Over-Temperature Safety Protection

It is recommended that you follow the warnings and turn the compressor OFF for 10 minutes after every 10 minutes of operation. However, the XPower Powerpack is equipped with an over-temperature safety protection feature that automatically turns the compressor off if it begins to overheat. Once the compressor cools down to its normal operating temperature it will automatically turn on again and continue inflating. You should turn the compressor off at the power switch if this safety feature engages, and allow the compressor to cool for 15 minutes before re-starting.



## WARNING: Risk of personal injury or damage to equipment

Never leave the compressor unattended once it has switched itself off due to overheating. It will turn on again and continue inflating when its internal temperature drops.

Turn the compressor OFF at the power switch after each use or any time the compressor turns off automatically.

## Inflating Tires

Table 3-3 Pressure Specifications for Common Items

Tires	PSI	Other Inflatables	PSI
520-13	26	Football	13
A-78-14	26	Basketball	9
E78-14	30	Volleyball	5
H-78-14	24	Lawn Tractor Tire	22
HR-78-15	28		
<b>Bicycle Tires</b>			
27-1 ¼	85		
20-1 ½	40		

**Note:** The information in the table is for reference only. For precise pressure specifications, refer to the information supplied with the article to be inflated.



## CAUTION

If the pressure gauge on the compressor indicates more than twice the recommended pressure for the object you are inflating, and you have only started to inflate the object, the valve connector is incorrectly connected to the valve stem. This may damage the XPower Powerpack. Remove and reattach the valve connector to the valve stem.

---

### **To inflate your vehicle, motorcycle, or bicycle tires:**

1. Place the valve connector securely on the tire valve stem, push it as far as possible to allow normal airflow, and close the thumb latch. If necessary, use a supplied nozzle adapter.
2. Turn the compressor on, and inflate your tire to the pressure specified by its manufacturer. Use Table 3-3, “Pressure Specifications for Common Items” on page 3–13 as a general guide only.
3. Turn the compressor OFF after appropriate pressure is reached.
4. Open the thumb latch and remove the valve connector from the valve stem.
5. Check air pressure with a pressure gauge.

---

**Note:** Leave the thumb latch in the open position for storing to relieve pressure on the internal mechanisms.

---

## Inflating Small Sports Equipment

You can use the compressor to inflate small sports equipment such as balls (soccer balls and footballs).





## CAUTION

The XPower Powerpack cannot be used to inflate large capacity inflatables such as float tubes, large air mattresses, and inflatable boats. These types of products require extended inflating times which may damage the compressor.

---

### To inflate small sports equipment:

1. Place the valve connector fully on or into the valve receptacle on the item. Go to Step 4.  
OR  
If necessary, use a supplied nozzle adaptor.
  2. Choose the appropriate nozzle adaptor, insert the nozzle adaptor into the valve stem and close the thumb latch.
  3. Insert nozzle adaptor into the valve receptacle of the item.
  4. Turn the compressor on and inflate to appropriate pressure.
- 



## WARNING: Fire hazard

Allow the compressor to cool down for 10 minutes after each 10 minutes of continuous operation.

---

5. Turn the compressor OFF before removing nozzle adaptor from valve stem.
  6. Remove nozzle adaptor from valve connector and store in storage compartment.
- 

**Note:** Leave the thumb latch in the open position for storing to relieve pressure on the internal mechanism.

---

# Using the Radio: XPower Powerpack 400R

For information about operating the radio, see page 2–5.

---

## Power Draw

The AM/FM radio on the back panel is powered by the internal battery in the XPower Powerpack 400R.

When turned on, the radio draws 30 mA, allowing you to use the radio for more than one month when the XPower Powerpack 400R is fully charged.

## Listening to the AM Band

Due to signal interference, you cannot listen to the AM band while using the XPower Powerpack 400R to operate an AC appliance.

## Connecting to an External Battery

You can extend battery operating times by connecting the XPower Powerpack to a larger external battery.

For example, an external 60 Ah battery gives approximately four times the operating time of the XPower Powerpack internal 20 Ah battery.



### **WARNING: Fire hazard**

Never allow jump-start cables' red and black clamps to touch each other or another common metal conductor. This could cause damage to the unit and/or create a sparking/explosion hazard. Always disconnect the jump-start cables from the unit after use and clip the plastic guard over the jump-start cable port.



### **WARNING: Fire hazard**

Jump-start cable clamps must be connected positive to positive (red clamp to battery "+") and negative to negative (black clamp to battery "-"). A reverse polarity connection (positive to negative) may cause damage to the unit and/or create a sparking/explosion hazard.

---



### **WARNING: Acid spills**

Use a sealed, non-spillable battery for indoor use. Common auto and marine batteries are not suitable for indoor use unless their fumes are vented outdoors. Common auto and marine batteries contain acid, which is hazardous if spilled. Wear eye protection and protective clothing when connecting the XPower Powerpack to an external battery.

---

#### **To connect the XPower Powerpack to an external battery using the jump-start cables:**

1. Connect the cables to the Jump-Start Cable Port on the left side of the XPower Powerpack.
  2. Connect the red positive (+) clip of the cables to the red positive (+) terminal of the external battery.
  3. Connect the black negative (–) clip of the cables to the black negative (–) terminal of the external battery.
- 



### **WARNING: Sparking and explosion**

Do not remove the cables from the Jump-Start Cable Port when the positive and negative clamps are connected to the terminals of the external battery.

---

#### **To disconnect the cables from an external battery and from the XPower Powerpack:**

1. To disconnect the XPower Powerpack from the external battery when the external battery is discharged or no longer needed, remove the red positive (+) clip, and then remove the black negative (–) clip.
  2. Remove the cables from the Jump-Start Cable Port.
  3. Recharge the XPower Powerpack as soon as possible after use.
- 



### **CAUTION**

Do not recharge the XPower Powerpack when an external battery is connected. The AC charger may be damaged.

---



# 4 Maintenance

Chapter 4 provides information on maintaining your internal battery, recharging options for the internal battery, and replacing user-replaceable parts.

Routine maintenance is required to keep your XPower Powerpack operating properly. Occasionally clean the exterior of the unit with a damp cloth to remove the accumulated dust and dirt.



## **WARNING: Shock hazard**

Disconnect all sources of AC power and DC power before performing any type of maintenance.

---

## Battery Maintenance

All rechargeable batteries gradually discharge when left standing, and you need to recharge them periodically to maintain maximum battery capacity. The AC Charger supplied with the XPower Powerpack is designed to regulate the charging process, ensuring that the battery is always fully charged but never overcharged. To ensure safe recharging and maximum battery life, recharge the XPower Powerpack only with the supplied charger or approved battery chargers.

s.



## **CAUTION**

Due to inherent self-discharge, lead acid batteries must be charged at least every 3 months, especially in a warm environment. Leaving a battery in a discharged state, or not recharging every 3 months, may result in permanent battery damage and poor jump-start performance.

---



### CAUTION

Do not attempt to recharge the XPower Powerpack battery if it is frozen. Gradually warm the frozen battery to 32 °F (0 °C) before recharging.

---

## Recharging the XPower Powerpack Battery

To check the battery's charge level, press the **Display Function** button.

---

**Note:** **Battery Charge (%)** status is only accurate when the XPower Powerpack has been disconnected from all appliances and all charging sources for fifteen minutes.

---

You can recharge the battery using:

- the fully automatic “plug-in-and-forget” AC Charger.
- the DC Charging Cable to recharge from your vehicle as you drive.
- a generator equipped with a regulated 12 V battery charging outlet.
- a solar panel.

## Recharging with the AC Charger

Recharging with the AC Charger is a true “plug-in-and-forget” charging method.

---



### CAUTION

Do not operate AC or DC appliances while the XPower Powerpack is being recharged with the AC Charger. The AC Charger may be permanently damaged if AC appliances or 12 V DC appliances are operated while the AC Charger is connected.

---

**To recharge with the AC Charger:**

1. Disconnect any 12 V DC appliance and turn the light switch to OFF.
2. Turn the AC Outlet ON/OFF switch to OFF.
3. Plug the AC Charger into a standard AC wall outlet.
4. Insert the AC Charger cable end into the Charger Input Socket located in the charger storage compartment.
5. While the XPower Powerpack is recharging, the green **Charging Status** light is flashing. If the battery is completely discharged, a typical recharge may take up to 35 hours. When fully charged, the green **Charging Status** light changes to steady and the XPower Powerpack is ready to use.

---

**Important:** The 35-hour charging time for the XPower Powerpack assumes that there is 120 V at the AC wall outlet. If the voltage is less than 120 V AC, it may take more than 35 hours to fully recharge the XPower Powerpack. If, after 35 hours of charging, the green **Charging Status** light is still flashing and not steady, continue to charge the unit for another 15 hours.

---

Once the battery is fully charged, the charging voltage and current automatically reduces to a maintenance level and the XPower Powerpack may be left permanently connected to the AC Charger. If your utility power is interrupted, the charging process automatically restarts when power returns.

## Recharging with the DC Charging Cable

Using the DC Charging Cable, the XPower Powerpack can be recharged while you drive your vehicle.

---

**Important:** Although the charge regulation circuitry in the XPower Powerpack does not operate with this charging method, most vehicle voltage regulators will ensure that the XPower Powerpack is not overcharged.

---



## **WARNING: Fire and explosion hazard**

Do not use this recharging method if your vehicle has abnormally high voltage electrical systems that operate above 15 V DC. This may lead to accumulations of hydrogen, causing exposure to fire and explosion hazard.

---



## **CAUTION**

Do not operate AC or DC appliances while the XPower Powerpack is being recharged with the DC Charging Cable from your vehicle.

---

### **To recharge the XPower Powerpack while you drive using the DC Charging Cable:**

1. While the vehicle engine is running, plug one end of the DC Charging Cable into the DC Power Socket of the XPower Powerpack.
2. Plug the opposite end of the DC Charging Cable into the vehicle's lighter socket or 12 V accessory outlet.
3. Once the XPower Powerpack is fully charged or if your vehicle's engine is not running, disconnect the DC Charging Cable from both sockets.

Most of the XPower Powerpack's capacity will be restored in four hours while the vehicle engine is running.

---

**Note:** The green **Charging Status** light will not illuminate when the XPower Powerpack is recharged through the DC Charging Cable.

---

**Note:** **Battery Charge (%)** indicator is only accurate when the XPower Powerpack has been disconnected from all appliances and all charging sources for fifteen minutes.

---

**Important:** Do not leave the XPower Powerpack permanently connected to the vehicle's lighter socket or 12 V accessory outlet.

---



---

## Recharging with a Generator's Regulated 12 V DC Outlet



### **WARNING: Fire and explosion hazard**

The generator output must be intended for battery charging and have an output of 15 V or less. An unregulated output or one that exceeds 15 V DC can damage the battery.

This may lead to accumulations of hydrogen, causing exposure to fire and explosion hazard.

---

Refer to the Owner's Guide accompanying your generator for detailed instructions on connecting the generator to a unit like the XPower Powerpack.

You can recharge the battery of the XPower Powerpack using a generator in several ways:

- Using the AC Charger to recharge the XPower Powerpack from a generator is possible, but would require extended generator running time.
- Using a generator which has an auxiliary regulated 12 V DC output designed for charging 12 V batteries. Most generators are equipped with them. Use this power source for faster charging.
- Using a generator with a regulated 12 V DC lighter socket. Follow the connection instructions in "Recharging with the DC Charging Cable" on page 4-3.

Most of the XPower Powerpack's battery capacity will be recharged in a few hours.

---

**Note:** **Battery Charge (%)** indicator is only accurate when the XPower Powerpack has been disconnected from all appliances and all charging sources for fifteen minutes.

---

---

## Recharging From a Solar Panel

Small, unregulated 12 V solar panels rated to produce a maximum of 2.5 A (or 30 W) can be used to charge the XPower Powerpack through the Charger Input Socket.

You will need to purchase a standard 5.5 mm OD × 2.5 mm (0.217" × 0.10") ID DC Coaxial (barrel type) connector to mate with the Charger Input Socket.

### To recharge with a solar panel:

1. Connect the solar panel's red positive (+) wire to the coaxial plug's inner contact.
2. Connect the solar panel's black negative (–) wire to the plug's outer contact.

Once the connector is inserted into the Charger Input Socket and the solar panel is placed in the sun, the XPower Powerpack charges automatically just as with the AC Charger. See “Recharging with the AC Charger” on page 4–2.

It takes about ten hours in direct sunlight to recharge the XPower Powerpack from a 2.5 A solar panel.

## Replacing the Internal Battery

### Battery Life

The high quality battery used in the XPower Powerpack will serve as a reliable power source for years when properly maintained.

To maximize battery life, it is important to recharge the XPower Powerpack battery after each use.

---

**Important:** Recharge the XPower Powerpack fully at least every three months if it is placed in storage or in a vehicle trunk. Store in a location that maintains a temperature range between 32 and 86 °F (0 and 30 °C).

---



**CAUTION**

Discharging the internal battery below 10.0 V will damage the battery and shorten its life.

## Obtaining a Replacement Battery

Replacement batteries are available from stores that specialize in and have a selection of lead acid, AGM (Absorbed Glass Mat) batteries.

Refer to Table 4-1 for a listing of batteries approved for use with the XPower Powerpack:

**Table 4-1** Approved Replacement Batteries

Replacement Battery	Where to Buy
Panasonic #LC-X1220P (12 V 20 Ah)	Panasonic: Tel: 1-800-833-9626 web: <a href="http://www.pasc.panasonic.com">www.pasc.panasonic.com</a>
	Digi-Key Tel: 1-800-344-4539
EnerSys #NPX-80 (12 V 20 Ah)	EnerSys Tel: 1-800-962-1287 (Eastern US) Tel: 1-800-423-4667 (Western US)
	web: <a href="http://www.EnersysStationary.com">www.EnersysStationary.com</a>

## Replacing the Battery



**WARNING: Shock or electrical hazard**

Read this entire section before disassembling the unit.

Before attempting to replace the internal battery, make sure you:

- Disconnect any charging cables, 12 V DC appliances, and AC appliances from the XPower Powerpack.

- Turn off the AC Outlet ON/OFF switch and turn off the light switch.
  - Remove the jump-start cables.
- 



### WARNING

If you do not know how to safely remove and install batteries, have this task performed by a qualified service technician.

---



### WARNING: Fire hazard

When installing the replacement battery, make sure the battery polarity is correct. Reverse polarity will damage the XPower Powerpack and could cause serious injury.

---

#### To replace the battery:

1. Place the XPower Powerpack upright on a stable, level surface.
2. On the XPower Powerpack, unscrew the four fasteners on the battery cover. Place the fasteners in the cover for safe keeping.

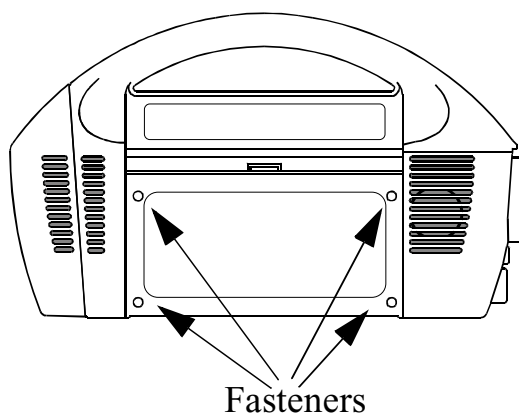

3. Disconnect the wires on the battery only.
4. After removing the old battery, position the new battery close to the back of the XPower Powerpack.

Make sure the positive battery terminal is next to the red positive (+) internal cable and the black negative terminal is next to the black negative (-) internal cable.

5. Securely fasten the bolt and washer that holds the red positive (+) cable to the positive (+) battery terminal and the black negative (-) cable to the negative (-) battery terminal.
6. Do not overtighten the bolt. Consult the battery manufacturer for torque specifications.
7. On the XPower Powerpack, replace the battery cover and the four fasteners.
8. Dispose of the old battery in an environmentally responsible manner.

## Replacing the Incandescent Light

To replace a light bulb:

1. Turn the light switch off.
2. Unscrew the cover and lens.
3. Gently grasp the bulb and pull to remove the light reflector assembly and the bulb.
4. While holding the light reflector assembly, gently unscrew the black knob at the back of the assembly.
5. Remove the old bulb and insert a replacement bulb of the same type and rating into the light reflector assembly.
6. Holding the light reflector assembly, gently screw the black knob on to the back of the assembly.
7. Reattach the lens and cover.

## Replacing the External Fuse

The replacement fuse must be rated at 250 A, 32 V DC. See page 2–9 for a diagram. To replace the external fuse:

1. Remove the fuse cover.
2. Unscrew the two bolts on the fuse.
3. Replace the fuse. Ensure that the replacement fuse is rated at 250 A, 32 V DC and is of the same type.
4. Tighten the fuse with the two bolts.
5. Replace the fuse cover.

# 5

## Troubleshooting

Troubleshooting will help you identify the common problems than can occur with the XPower Powerpack.

Read this chapter before calling Customer Service.

If you cannot solve the problem with the XPower Powerpack, record the information asked for on “Information About Your System” on page B-8 and then call Customer Service at 1-800-394-0440.

### Common Problems

#### Buzz in Audio Equipment

Some inexpensive stereo systems have inadequate internal power-supply filtering and may buzz slightly when powered by the XPower Powerpack. The best solution to eliminate the buzzing is to use an audio system with a good quality filter.

#### Television Interference

The XPower Powerpack is shielded to minimize interference with TV signals. If TV signals are weak, you may see interference in the form of lines scrolling across the TV screen. Try one of the following suggestions to minimize or eliminate the interference:

- Use an extension cord to increase the distance between the XPower Powerpack and the TV, antenna, and cables.
- Adjust the orientation of the XPower Powerpack, television, antenna, and cables.
- Maximize TV signal strength by using a better antenna. Use a shielded antenna cable where possible.

- Try a different TV. Different models vary considerably in their susceptibility to interference.

## Troubleshooting Reference



### **WARNING: Electric shock hazard**

Do not remove the cover of the XPower Powerpack or disassemble the XPower Powerpack except to replace the internal battery or 250 A fuse. The XPower Powerpack does not contain any internal user-serviceable parts and attempting to service the unit yourself could result in electrical shock or burn.

Table 5-1 Troubleshooting reference

Problem	Possible Cause	Solution
AC appliance will not operate; audible alarm is not sounding.	<p>AC appliance rated more than 320 W, the safety overload has tripped.</p> <p>AC appliance is rated less than 320 W, high starting surge has tripped the safety overload.</p>	<p>Use an AC appliance with a power rating less than 320 W.</p> <p>AC appliance may exceed the XPower Powerpack's surge capability. Use an AC appliance with a starting surge within the XPower Powerpack surge rating.</p>
Overload shutdown	Appliance power requirements exceed the capability of the XPower Powerpack.	Unplug the appliance and confirm that the appliance's power requirement is 320 W or less before attempting to restart the appliance.



**Table 5-1** Troubleshooting reference

Problem	Possible Cause	Solution
AC appliance will not operate; audible alarm is sounding.	<p>Battery has discharged to 10.5 V.</p> <p>Inverter has overheated due to poor ventilation or excessively warm environmental conditions.</p>	<p>Turn the AC Outlet ON/OFF switch off and recharge the XPower Powerpack.</p> <p>Turn the AC Outlet ON/OFF switch off and allow the XPower Powerpack to cool for 15 minutes or more. Clear blocked fan opening or remove objects covering the unit, then restart the XPower Powerpack. Move to a cooler environment.</p>
Over-temperature shutdown	<p>Inverter has overheated due to poor ventilation or excessively warm environmental conditions.</p>	<p>Turn off the AC Outlet ON/OFF switch, and let the XPower Powerpack cool down.</p>
Alarm sounds	<p>Internal battery is nearly discharged. (11.0 V). If you ignore this warning, the XPower Powerpack automatically switches off when the battery reaches 10.5 V.</p>	<p>Turn the AC outlet ON/OFF switch OFF and recharge the XPower Powerpack.</p>
Run time is less than expected.	<p>Internal battery is not fully charged.</p> <p>AC appliance power consumption is higher than expected.</p>	<p>Recharge using the AC Charger, until green <b>Charging Status</b> light is steady.</p> <p>Check AC appliance power or wattage rating (or current draw for 12 V DC appliances) and compare with Table 3-1 on page 3–5 and Table 3-2 on page 3–9.</p>

**Table 5-1** Troubleshooting reference

<b>Problem</b>	<b>Possible Cause</b>	<b>Solution</b>
Measured AC output voltage is too low.	Use of an average-reading AC voltmeter to read output voltage.	The modified sine wave (MSW) output of the XPower Powerpack requires a true RMS reading meter, such as the Fluke 87 series, for accurate measurement.
	Battery is almost fully discharged.	Press Display Function button to verify battery status and recharge the XPower Powerpack as necessary. “Battery Charge %” reading on the digital display is only accurate when the XPower Powerpack has been disconnected from all appliances and all charging sources for fifteen minutes.
<b>Charging Status</b> light is OFF when AC Charger is connected	No AC power at the AC wall outlet.	Ensure power is available at the AC wall outlet.
	AC Charger is faulty.	Replace the AC Charger.
Green <b>Charging Status</b> light is flashing (indicating recharging) and Battery Charge (%) does not turn on.	Battery Charge (%) reading on digital display is only accurate when the XPower Powerpack has been disconnected from all appliances and all charging sources for fifteen minutes.	Unplug the charging sources and any appliances and let the XPower Powerpack rest for 15 minutes to obtain an accurate reading.

**Table 5-1** Troubleshooting reference

Problem	Possible Cause	Solution
<p>Green <b>Charging Status</b> light is still flashing and hasn't changed to steady after 50 hours of charging.</p>	<p>The voltage at the AC wall outlet is less than 120 V AC.</p> <p>Internal battery is permanently damaged.</p>	<p>Use AC wall outlet that supplies 120 V AC.</p> <p>Replace the battery.</p>
<p>The compressor runs but won't inflate.</p>	<p>The valve connector may not be securely placed on the valve stem.</p> <p>The item being inflated may have a leak.</p>	<p>Check that the valve connector is securely placed on the valve stem before closing the thumb latch.</p> <p>Check that the item being inflated has no leaks.</p> <p>Check the compressor hose for any breaks or leaks at connections.</p>
<p>The compressor runs slowly.</p>	<p>The compressor may have overheated from excessive use.</p> <p>Battery voltage is too low.</p>	<p>Turn off the compressor and let it cool down.</p> <p>Check the condition of the internal battery. The battery may need to be recharged or replaced.</p>

**Table 5-1** Troubleshooting reference

<b>Problem</b>	<b>Possible Cause</b>	<b>Solution</b>
The engine being jump-started will not start.	XPower Powerpack battery is not fully charged.	Recharge the XPower Powerpack battery.
	The engine condition is poor.	Have the engine serviced.
	External fuse (250 A) is blown.	Replace 250 A, 32 V fuse with same type and ratings.
	The engine start capacity exceeds the XPower Powerpack jump-start capability.	
The battery clamps of the jump-start cables measure zero volts.	External fuse (250 A) is blown.	Replace 250 A, 32 V fuse with same type and ratings.
The light does not turn on.	Light bulb has burnt out.	Remove lens cover and replace bulb with one of the same type and rating.
The AM radio does not work or buzzes continuously (XPower Powerpack 400R only).	The XPower Powerpack AC outlets are being used, causing interference.	Turn off the AC outlets.

# A Specifications

## Electrical Specifications

12 V DC Section	
Internal battery type	sealed, AGM (Absorbed Glass Mat) lead acid
Internal battery voltage (nominal)	12 V DC
Internal battery capacity (minimum)	20 Ah
Internal battery CCA rating	200 CCA
DC Power Socket (maximum continuous load)	12 A with automatic reset
Built-in incandescent light (replaceable)	5 W bulb
Jump-start cable port	50 A
Jump-start fuse (external—user replaceable, replacement part # 066-0191)	250 A

## Specifications

---

<b>AC Power Section</b>	
Output power <ul style="list-style-type: none"><li>• Continuous output power</li><li>• Five minute AC output power</li><li>• AC output surge capacity</li></ul>	320 W 400 W 600 W
Output voltage	115 ± 10 V AC RMS
Output frequency	60 Hz ± 4 Hz
Output wave form	modified sinewave
No load current draw	<0.20 A DC
Input voltage range	10.5 to 15.0 V DC
Low battery alarm	11.0 V DC
Low battery shutdown	10.5 V DC
High battery voltage shutdown	Yes, automatic reset
Over temperature shutdown	Yes, automatic reset
Overload shutdown	Yes, automatic reset
AC output short circuit protection	Yes, automatic reset
Fuse (internal)	2 x 25 A or 1 x 50 A
Operating temperature range	32 – 104 °F (0 – 40 °C)
Storage temperature range	32 – 86°F (0 – 30 °C)

<b>Internal Battery Charging Controller System</b>	
AC Charger bulk charging current	750 mA
Peak charging voltage (nominal)	14.2 V
Charge restart voltage (nominal)	12.9 V
Float charge after full charge is completed (nominal)	1 mA
AC Charger input socket maximum current	2.5 A

<b>Air Compressor</b>	
Pressure	250 PSI (lb./in <sup>2</sup> )

<b>Radio (XPower Powerpack 400R only)</b>	
AM Frequency	526–1606 KHz
FM Frequency	87-105 MHz

<b>Accessories</b>	
Jump-start cables (replacement part # 449-0207-01-01)	24" (0.61 m), 4 AWG wire with black and red battery clamps
DC charge cable (replacement part # 449-0187-01-01)	39" (1 m) 18 AWG with male to male lighter plugs
AC Charger input (replacement part # 074-1004)	120 ± 10 V AC, 60 Hz
Nozzle adaptor (for air compressor, replacement part # 160-0015-01-01)	two nozzle adaptors
	one sports needle adaptor

## Physical Specifications

Physical specifications	XPower Powerpack 400 Plus	XPower Powerpack 400R
Depth	8" (20.3 cm)	8" (20.3 cm)
Width	16" (40.8 cm)	16" (40.8 cm)
Height	9 ½" (24.1 cm)	9 ½" (24.1 cm)
Weight	21.8 lb. (9.9 kg)	23 lb. (10.5 kg)

**Important:** All specifications are subject to change without notice.





# B Warranty and Product Information

Appendix B contains the warranty for your XPower Powerpack 400 Plus and XPower Powerpack 400R as well as instructions for returning the product for servicing.

Appendix B also has a form where you can record information, “Information About Your System” on page B-8, in case you need to contact Customer Service.

# Warranty

**What does this warranty cover?** This Limited Warranty is provided by Xantrex Technology, Inc. ("Xantrex") and covers defects in workmanship and materials in your XPower Powerpack 400 Plus and XPower Powerpack 400R. This warranty lasts for a Warranty Period of **6 months** from the date of purchase at point of sale to you, the original end user customer.

**What will Xantrex do?** Xantrex will, at its option, repair or replace the defective product free of charge, provided that you notify Xantrex of the product defect within the Warranty Period, and provided that Xantrex through inspection establishes the existence of such a defect and that it is covered by this Limited Warranty.

Xantrex will, at its option, use new and/or reconditioned parts in performing warranty repair and building replacement products. Xantrex reserves the right to use parts or products of original or improved design in the repair or replacement. If Xantrex repairs or replaces a product, its warranty continues for the remaining portion of the original Warranty Period or 90 days from the date of the return shipment to the customer, whichever is greater. All replaced products and all parts removed from repaired products become the property of Xantrex.

Xantrex covers both parts and labor necessary to repair the product, and return shipment to the customer via a Xantrex-selected non-expedited surface freight within the contiguous United States and Canada. Alaska and Hawaii are excluded. Contact Xantrex Customer Service for details on freight policy for return shipments outside of the contiguous United States and Canada.

**How do you get service?** If your product requires troubleshooting or warranty service, contact your merchant. If you are unable to contact your merchant, or the merchant is unable to provide service, contact Xantrex directly at:

Phone: 1-800-394-0440 (toll free)

1-360-925-5097 (direct)

Fax: 1-360-925-5143 (direct)

Email: [CustomerService@xantrex.com](mailto:CustomerService@xantrex.com)

Direct returns may be performed according to the Xantrex Return Material Authorization Policy described in your product manual. For some products, Xantrex maintains a network of regional Authorized Service Centers. Call Xantrex or check our website to see if your product can be repaired at one of these facilities.

In any warranty claim, dated proof of purchase must accompany the product and the product must not have been disassembled or modified without prior written authorization by Xantrex.

Proof of purchase may be in any one of the following forms:

- The dated purchase receipt from the original purchase of the product at point of sale to the end user, or
- The dated dealer invoice or purchase receipt showing original equipment manufacturer (OEM) status, or
- The dated invoice or purchase receipt showing the product exchanged under warranty

**What does this warranty not cover?** This Limited Warranty does not cover normal wear and tear of the product or costs related to the removal, installation, or troubleshooting of the customer's electrical systems. This warranty does not apply to and Xantrex will not be responsible for any defect in or damage to:

- a) the product if it has been misused, neglected, improperly installed, physically damaged or altered, either internally or externally, or damaged from improper use or use in an unsuitable environment;
- b) the product if it has been subjected to fire, water, generalized corrosion, biological infestations, or input voltage that creates operating conditions beyond the maximum or minimum limits listed in the Xantrex product specifications including high input voltage from generators and lightning strikes;
- c) the product if repairs have been done to it other than by Xantrex or its authorized service centers (hereafter "ASCs");
- d) the product if it is used as a component part of a product expressly warranted by another manufacturer;
- e) the product if its original identification (trade-mark, serial number) markings have been defaced, altered, or removed.

# Disclaimer

## Product

THIS LIMITED WARRANTY IS THE SOLE AND EXCLUSIVE WARRANTY PROVIDED BY XANTREX IN CONNECTION WITH YOUR XANTREX PRODUCT AND IS, WHERE PERMITTED BY LAW, IN LIEU OF ALL OTHER WARRANTIES, CONDITIONS, GUARANTEES, REPRESENTATIONS, OBLIGATIONS AND LIABILITIES, EXPRESS OR IMPLIED, STATUTORY OR OTHERWISE IN CONNECTION WITH THE PRODUCT, HOWEVER ARISING (WHETHER BY CONTRACT, TORT, NEGLIGENCE, PRINCIPLES OF MANUFACTURER'S LIABILITY, OPERATION OF LAW, CONDUCT, STATEMENT OR OTHERWISE), INCLUDING WITHOUT RESTRICTION ANY IMPLIED WARRANTY OR CONDITION OF QUALITY, MERCHANTABILITY OR FITNESS FOR A PARTICULAR PURPOSE. ANY IMPLIED WARRANTY OF MERCHANTABILITY OR FITNESS FOR A PARTICULAR PURPOSE TO THE EXTENT REQUIRED UNDER APPLICABLE LAW TO APPLY TO THE PRODUCT SHALL BE LIMITED IN DURATION TO THE PERIOD STIPULATED UNDER THIS LIMITED WARRANTY.

IN NO EVENT WILL XANTREX BE LIABLE FOR ANY SPECIAL, DIRECT, INDIRECT, INCIDENTAL OR CONSEQUENTIAL DAMAGES, LOSSES, COSTS OR EXPENSES HOWEVER ARISING WHETHER IN CONTRACT OR TORT INCLUDING WITHOUT RESTRICTION ANY ECONOMIC LOSSES OF ANY KIND, ANY LOSS OR DAMAGE TO PROPERTY, ANY PERSONAL INJURY, ANY DAMAGE OR INJURY ARISING FROM OR AS A RESULT OF MISUSE OR ABUSE, OR THE INCORRECT INSTALLATION, INTEGRATION OR OPERATION OF THE PRODUCT.

## Exclusions

If this product is a consumer product, federal law does not allow an exclusion of implied warranties. To the extent you are entitled to implied warranties under federal law, to the extent permitted by applicable law they are limited to the duration of this Limited Warranty. Some states and provinces do not allow limitations or exclusions on implied warranties or on the duration of an implied warranty or on the limitation or exclusion of incidental or consequential damages, so the above limitation(s) or exclusion(s) may not apply to you. This Limited Warranty gives you specific legal rights. You may have other rights which may vary from state to state or province to province.

## Warning: Limitations On Use

Please refer to your product manual for limitations on uses of the product.

**SPECIFICALLY, PLEASE NOTE THAT THE XPower Powerpack 400 Plus and XPower Powerpack 400R SHOULD NOT BE USED IN CONNECTION WITH LIFE SUPPORT SYSTEMS OR OTHER MEDICAL EQUIPMENT OR DEVICES. WITHOUT LIMITING THE GENERALITY OF THE FOREGOING, XANTREX MAKES NO REPRESENTATIONS OR WARRANTIES REGARDING THE USE OF THE XANTREX XPower Powerpack 400 Plus and XPower Powerpack 400R IN CONNECTION WITH LIFE SUPPORT SYSTEMS OR OTHER MEDICAL EQUIPMENT OR DEVICES.**

Please note that the XPower Powerpack 400 Plus and XPower Powerpack 400R are not intended for use as an uninterruptible power supply and Xantrex makes no warranty or representation in connection with any use of the product for such purposes.

## Return Material Authorization Policy

Before returning a product directly to Xantrex you must obtain a Return Material Authorization (RMA) number and the correct factory "Ship To" address. Products must also be shipped prepaid. Product shipments will be refused and returned at your expense if they are unauthorized, returned without an RMA number clearly marked on the outside of the shipping box, if they are shipped collect, or if they are shipped to the wrong location.

When you contact Xantrex to obtain service, please have your instruction manual ready for reference and be prepared to supply:

- The serial number of your product
- Information about the installation and use of the unit
- Information about the failure and/or reason for the return
- A copy of your dated proof of purchase

Record these details in "Information About Your System" on page B-8.

# Return Procedure

1. Package the unit safely, preferably using the original box and packing materials. Please ensure that your product is shipped fully insured in the original packaging or equivalent. This warranty will not apply where the product is damaged due to improper packaging.
2. Include the following:
  - The RMA number supplied by Xantrex Technology, Inc. clearly marked on the outside of the box.
  - A return address where the unit can be shipped. Post office boxes are not acceptable.
  - A contact telephone number where you can be reached during work hours.
  - A brief description of the problem.
3. Ship the unit prepaid to the address provided by your Xantrex customer service representative.

**If you are returning a product from outside of the USA or Canada** In addition to the above, you **MUST** include return freight funds and are fully responsible for all documents, duties, tariffs, and deposits.

**If you are returning a product to a Xantrex Authorized Service Center (ASC)** A Xantrex return material authorization (RMA) number is not required. However, you must contact the ASC prior to returning the product or presenting the unit to verify any return procedures that may apply to that particular facility.

# Out of Warranty Service

If the warranty period for your XPower Powerpack 400 Plus and XPower Powerpack 400R has expired, if the unit was damaged by misuse or incorrect installation, if other conditions of the warranty have not been met, or if no dated proof of purchase is available, your inverter may be serviced or replaced for a flat fee.

To return your XPower Powerpack 400 Plus and XPower Powerpack 400R for out of warranty service, contact Xantrex Customer Service for a Return Material Authorization (RMA) number and follow the other steps outlined in “Return Procedure” on page B-6.

Payment options such as credit card or money order will be explained by the Customer Service Representative. In cases where the minimum flat fee does not apply, as with incomplete units or units with excessive damage, an additional fee will be charged. If applicable, you will be contacted by Customer Service once your unit has been received.

---

## Information About Your System

As soon as you open your XPower Powerpack 400 Plus and XPower Powerpack 400R package, record the following information and be sure to keep your proof of purchase.

- Serial Number \_\_\_\_\_
- Purchased From \_\_\_\_\_
- Purchase Date \_\_\_\_\_

If you need to contact Customer Service, please record the following details before calling. This information will help our representatives give you better service.

- Type of installation [e.g. RV, truck, vehicle, home] \_\_\_\_\_
- Warning, Error or Panel Fault Message \_\_\_\_\_
- Appliances operating when problem occurred \_\_\_\_\_
- Description of problem \_\_\_\_\_

---

---



---

# **xantrex**

**t 1-800-394-0440 (toll free in North America)  
1-360-925-5097 (direct)**  
**f 1-800-994-7828 (toll free in North America)  
1-360-925-5143 (direct)**  
**e customerservice@xantrex.com**

**www.xantrex.com**



**ATTENTION:** When Operating the Radio and AC loads at the same time, you may experience static in the reception of both AM and FM bands. For clear reception, operate the Radio independent of any AC loads.

## Free Manuals Download Website

<http://myh66.com>

<http://usermanuals.us>

<http://www.somanuals.com>

<http://www.4manuals.cc>

<http://www.manual-lib.com>

<http://www.404manual.com>

<http://www.luxmanual.com>

<http://aubethermostatmanual.com>

Golf course search by state

<http://golfingnear.com>

Email search by domain

<http://emailbydomain.com>

Auto manuals search

<http://auto.somanuals.com>

TV manuals search

<http://tv.somanuals.com>