

**DC to AC
Power Inverter**

jazz™
300

Owner's Guide

XANTREX

Download from www.Somanuals.com. All Manuals Search And Download Here. **Smart Choice For Power**

Trademarks and Disclaimer

Jazz is a trademark of Xantrex International. Xantrex is a registered trademark of Xantrex Technology Inc. © 2001 Xantrex International. All rights reserved.

Jazz 300 Owner's Guide © April 2001 Xantrex International.

UNLESS SPECIFICALLY AGREED TO IN WRITING, XANTREX TECHNOLOGY INC.
("XANTREX")

- (a) MAKES NO WARRANTY AS TO THE ACCURACY, SUFFICIENCY OR SUITABILITY OF ANY TECHNICAL OR OTHER INFORMATION PROVIDED IN ITS MANUALS OR OTHER DOCUMENTATION.
- (b) ASSUMES NO RESPONSIBILITY OR LIABILITY FOR LOSS OR DAMAGE, WHETHER DIRECT, INDIRECT, CONSEQUENTIAL OR INCIDENTAL, WHICH MIGHT ARISE OUT OF THE USE OF SUCH INFORMATION. THE USE OF ANY SUCH INFORMATION WILL BE ENTIRELY AT THE USER'S RISK.

Contact Information

Tel: 604.422.8595 or 1.800.670.0707

Fax: 604.420.1591 or 1.800.994.7828

Email: support.jazz@xantrex.com

Web: www.xantrex.com

Part No. 445-0120-01-01 Revision 2

Contents

| | |
|--|----|
| Safety First | 1 |
| 1 Introduction | 4 |
| 2 Installation Guidelines | 6 |
| 3 Using the Jazz 300 | 9 |
| 4 Troubleshooting | 16 |
| 5 Limited Warranty (USA and Canada only) | 20 |
| 6 Out-of-Warranty Service Information | 24 |

Safety First ...

Incorrect installation or misuse of the Jazz 300 may result in danger to the user or hazardous conditions. We urge you to pay special attention to all **CAUTION** and **WARNING** statements. **CAUTION** statements identify conditions or practices that may result in damage to the Jazz 300 or to other equipment. **WARNING** statements identify conditions that may result in personal injury or loss of life.



WARNING! Shock hazard. Keep away from children.

- The Jazz 300 generates the same potentially lethal AC power as a normal household wall outlet. Treat it with the same respect that you would any AC outlet.
- Do not insert foreign objects into the Jazz 300's AC outlets, fan or vent openings.
- Do not expose the Jazz 300 to water, rain, snow or spray.
- Do not, under any circumstances, connect the Jazz 300 to utility power AC distribution wiring.



WARNING! Heated surface.

- The Jazz 300's housing may become uncomfortably warm, reaching 140°F (60°C) under extended high power operation. Ensure at least 2 inches (5 cm) of air space is maintained on all sides of the Jazz 300. During operation, keep away from materials that may be affected by high temperatures.



WARNING! Explosion hazard.

- Do not use the Jazz 300 in the presence of flammable fumes or gases, such as in the bilge of a gasoline powered boat, or near propane tanks. Do not use the Jazz 300 in an enclosure containing automotive-type, lead-acid batteries. These batteries, unlike sealed batteries, vent explosive hydrogen gas, which can be ignited by sparks from electrical connections.
- When working on electrical equipment always ensure someone is nearby to help you in an emergency.



CAUTION!

- Do not connect live AC power to the Jazz 300's AC outlets. The inverter will be damaged even if it is switched OFF.
- Do not connect any AC load, which has its neutral conductor connected to ground, to the Jazz 300.
- Do not expose the Jazz 300 to temperatures exceeding 104°F (40°C).



CAUTION! Do not use the Jazz 300 with the following equipment:

- Small battery operated products such as rechargeable flashlights, some rechargeable shavers, and night-lights that are plugged directly into an AC receptacle to recharge.
- Certain battery chargers for battery packs used in hand powered tools. These chargers will have warning labels stating that dangerous voltages are present at the charger's battery terminals.
- Connect Jazz 300 only to batteries with a 12-volt nominal output. A battery with 6-volt nominal output will not supply enough voltage and a battery with 24-volt nominal output will damage the inverter.

1 Introduction

Thank you for purchasing the Jazz™ 300 Power Inverter. The Jazz 300 is a compact and highly portable power inverter from Xantrex, the leader in the field of high frequency inverter design. From the 12-volt outlet in your vehicle or boat, or directly from a dedicated 12-volt battery, the Jazz 300 will efficiently and reliably power a wide variety of household AC products, such as TVs, computers, VCRs, and many more. The Jazz 300 is designed to provide years of trouble-free operation and includes automatic safety monitoring circuitry to protect the inverter, and your battery, from inadvertent overload conditions.

Read this guide before installing or using the Jazz 300 and save it for future reference.

Safety Features

These advanced safety features are built into the Jazz 300:

- Electronic overload protection with automatic shutdown.
- Built-in internal backup DC fuse provides added safety.
- Low battery voltage warning followed by automatic shutdown.
- High input voltage protection with automatic shutdown.
- Over temperature protection with automatic shutdown.
- Output short circuit protection.

2 Installation Guidelines

Selecting a Suitable Location

For safe and optimum performance, install the Jazz 300 in a location that is...

- **Dry.** Do not expose to water drip or spray.
- **Cool.** Operate only in ambient temperatures between 32°F (0°C) and 104°F (40°C). Keep away from furnace heating vents or other heat producing equipment.
- **Well ventilated.** Allow at least 2 inches (5 cm) clearance above and on all sides of the unit for proper cooling.
- **Safe.** Do not install Jazz 300 in a compartment with batteries or flammable liquids, such as gasoline, or explosive vapors.
- **Clean and free of dust and dirt.** This is especially important if the Jazz 300 is used in a work environment.

Using the DC Cable-Plug

Due to limitations in the common 12-volt outlet in a vehicle or boat, the Jazz 300 should only be used to supply AC power to products that require 150 watts (about 1.3 amps) or less. If your application requires more than 150 watts (but less than 240 watts continuous) or has a high start-up surge, see **Using the DC Cable-Clips**.

1. Attach the ring type connector marked with red to the positive (+) DC terminal on the Jazz 300 and attach the ring connector marked with black to the negative (-) DC terminal.



CAUTION! A reverse polarity connection (positive to negative) may damage the Jazz 300. Damage caused by a reverse polarity connection is not covered under warranty.

2. Tighten the nut on each DC terminal by hand until it is snug. Do not over tighten.
3. Insert the plug of this cable into the 12-volt outlet and switch the unit ON. See Section 4 if the Jazz 300 does not operate properly after being connected.
4. When the Jazz 300 is not in use, unplug it from the 12-volt outlet to prevent slight discharge of the battery.

Using the DC Cable-Clips

By directly connecting the Jazz 300 to a 12-volt battery with the **DC Cable-Clips**, you can operate products with power requirements up to 240 watts continuous. If you want to permanently connect the Jazz 300 to a battery, contact Xantrex customer service (see **Contact Information**).

1. Follow steps 1 and 2 above (**Using the DC Cable-Plug**) to attach the ring type connectors.
2. Attach the black negative clip to the negative (-) battery terminal
3. Attach the red positive clip to the positive (+) battery terminal. Make sure both clips are securely connected to the battery terminals, as a loose connection will cause excessive voltage drop and may cause the cables to overheat resulting in equipment damage or fire.
4. Switch the Jazz 300 ON. See Section 4 if the Jazz 300 does not operate properly after being connected.
5. When the Jazz 300 is not in use, disconnect the **DC Cable-Clips** from the battery.

3 Using the Jazz 300

The Jazz 300 is capable of continuously powering most 120-volt AC products that use 240 watts or less. Its AC output waveform, called “modified-sine wave”, is designed to function similarly to the sine wave shape of utility power.

The power, or “wattage”, rating of AC products is the average power they use. When many AC products are first switched on, they initially consume more power than their power rating. TVs, monitors, and electric motors are examples of products that have high “surge” requirements at start up. Although the Jazz 300 can supply momentary surge power as high as 500 watts, occasionally some products rated less than 240 watts may exceed its surge capabilities and trigger its safety overload shutdown feature. If this problem occurs when attempting to operate several AC products at the same time, try first switching on the inverter with all AC products switched off, then one by one switch each on, starting with the high surge product first.

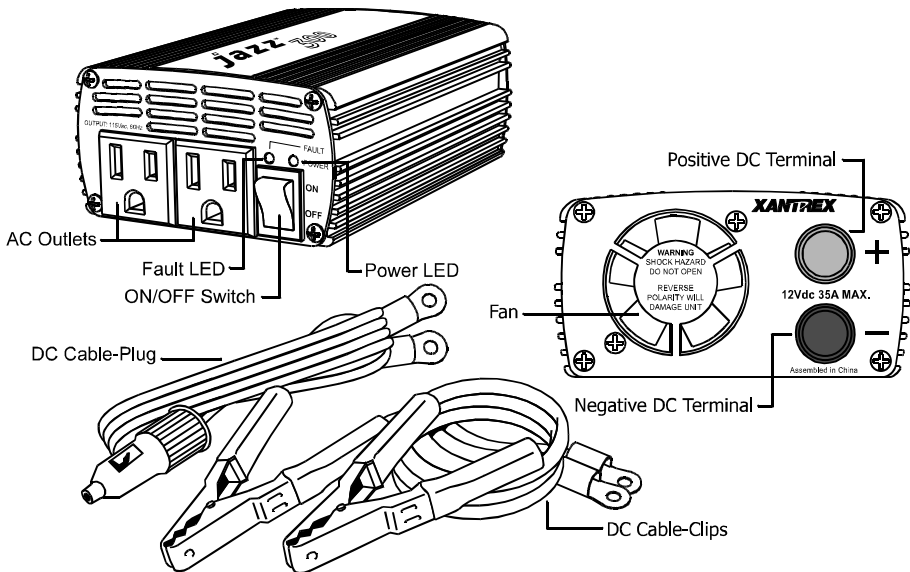

Figure 1 - Features and Accessories

Indicators and Controls (see Figure 1)

- Two AC outlets are provided on one end of the Jazz 300. Any combination of 120-volt AC products with a total continuous power consumption of 240 watts or less may be plugged in.
- The ON/OFF switch enables output AC power at the AC outlets when switched ON.
- The green POWER light indicates AC power is present at the two AC outlets and the Jazz 300 is operating normally.
- The red FAULT light indicates inverter shutdown caused by low or high voltage, overload or excessive temperature.

Inverter Operation

1. When properly connected to a 12-volt outlet or battery, turning the ON/OFF switch ON, will illuminate the green POWER light, and deliver AC power to the two outlets.
2. Plug the AC product(s) you wish to operate into the AC outlet(s) and switch them on, one at a time.

3. As the battery charge is used up, battery voltage begins to fall. When the Jazz 300 senses that the voltage at its DC input has dropped to 10.7 volts, an audible alarm sounds. This allows time for computers or other sensitive devices to be shut down.
4. If the audible alarm is ignored, the Jazz 300 will automatically shut down when the battery voltage drops to 10.0 volts. This prevents battery damage from excessive discharge. After auto shut down, the red FAULT light illuminates.



IMPORTANT: Vehicle batteries are designed to provide brief periods of very high current needed for engine starting. They are not intended for constant deep discharge. Regularly operating the Jazz 300 from a vehicle battery until the low voltage alarm sounds will shorten the life of the battery. Consider connecting the Jazz 300 to a separate deep discharge type battery if you will be frequently running electrical products for extended periods of time.

5. If an AC product rated higher than 240 watts (or which draws excessive surge power) is connected, the Jazz 300 will shut down. The red FAULT light will turn on.

6. If the Jazz 300 exceeds a safe operating temperature, due to insufficient ventilation or a high temperature environment, it will automatically shut down. The red FAULT light will turn on and the audio warning will sound.
7. Should a defective battery charging system cause the battery voltage to rise to dangerously high levels, the Jazz 300 automatically shuts down.



CAUTION! Although the Jazz 300 incorporates protection against over-voltage, it may still be damaged if the input voltage exceeds 16 volts.

8. The cooling fan is designed to operate only when output power is greater than 100 watts.
9. In the event of an overload, low battery voltage or overheating, the Jazz 300 will automatically shut down (See Section 4).

Battery Operating Time

Operating time will vary depending on the charge level of the battery, its capacity and the power level drawn by the particular AC load. With a typical vehicle battery and a 100-watt load (such as a small TV), an operating time of 2–3 hours or more can be expected.

When using a vehicle battery as a power source, it is strongly recommended to start the vehicle every hour or two to recharge the battery before its capacity drops too low. The Jazz 300 can operate while the engine is running, but the normal voltage drop that occurs during starting may trigger the Jazz 300's low voltage shutdown feature.

Because the Jazz 300 draws less than 0.2 amps with the ON/OFF switch in the ON position and with no AC products connected, it has minimal impact on battery operating times.

Interference with Electronic Equipment

Generally, most AC products operate with the Jazz 300 just as they would with household AC power. Below is information concerning two possible exceptions.

Buzzing Sound in Audio Systems and Radios - Some inexpensive stereo systems, “boom boxes”, and AM-FM radios have inadequate internal power supply filtering and “buzz” slightly when powered by the Jazz 300. Generally, the only solution is an audio product with a higher quality filter.

Television Interference - The Jazz 300 is shielded to minimize its interference with TV signals. However, with weak TV signals interference may be visible in the form of lines scrolling across the screen. The following should minimize or eliminate the problem:

- Use an extension cord to increase the distance between the Jazz 300 and the TV, antenna and cables.
- Adjust the orientation of the Jazz 300, television, antenna and cables.
- Maximize TV signal strength by using a better antenna and use shielded antenna cable where possible.
- Try a different TV. Different models of televisions vary considerably in their susceptibility to interference.

4 Troubleshooting

PROBLEM: AC product will not operate, no inverter lights are ON.

Possible Cause

Battery is defective.

Inverter has been connected with reverse DC input polarity.

Loose cable connections.

Suggested Remedy

Check battery and replace if required.

Check connection to battery. Probable inverter damage has occurred. Have unit repaired (not covered by warranty).

Check cables and connections. Tighten as required.

PROBLEM: Inverter will run some small loads, but not larger ones.

Possible Cause

Voltage drop across DC cables.

Suggested Remedy

Shorten cables or use heavier cables.

PROBLEM: Measured inverter output is too low.

Possible Cause

Standard “average-reading” AC voltmeter used to measure output voltage, resulting in an apparent reading 5 to 15 volts too low.

Battery voltage is too low.

Suggested Remedy

Inverter’s “modified sine wave” output requires “true RMS” voltmeter, such as Fluke 87 series multimeter, for accurate measurement.

Recharge battery.

PROBLEM: Alarm is sounding.

Possible Cause

Low voltage shutdown or thermal shutdown has occurred.

Suggested Remedy

Shorten cables or use heavier cables. Recharge battery. Allow unit to cool. Improve air circulation around unit. Locate unit to a cooler environment. Reduce load if continuous operation is required.

PROBLEM: Battery run time is less than expected.

Possible Cause

AC product power consumption is higher than rated.

Battery is old or defective.

Battery is not being properly charged.

Power dissipation in DC cables.

Suggested Remedy

Use a larger battery to make up for increased power requirement.

Replace battery.

Many simple chargers are unable to charge a battery fully. Replace charger with better model such as a TRUECHARGE™ smart charger.

Use shorter/heavier DC cables.

PROBLEM: AC product will not operate, red FAULT light ON.

Possible Cause

AC product(s) connected are rated at more than 240 watts; overload shutdown has occurred.

AC Product is rated less than 240 watts; high starting surge has caused overload shutdown.

Battery is discharged (alarm is sounding).

Jazz 300 has overheated due to poor ventilation and has caused over temperature shutdown.

Input voltage is greater than 15.0 volts.

Suggested Remedy

Use product with a power rating less than 240 watts (or 120 volts/2.0 amps).

Product exceeds inverter's surge capability. Use a product with starting surge power within the Jazz 300's capability.

Recharge battery.

Switch Jazz 300 OFF and allow to cool for 15 minutes. Clear blocked fan or remove objects covering unit. Locate unit to a cooler environment. Reduce load if continuous operation is required. Restart.

Verify charging system is properly regulated and battery is 12 volts nominal.

5 **Limited Warranty (USA and Canada only)**

What Does This Warranty Cover? Xantrex manufactures its products from parts and components that are new or equivalent to new, in accordance with industry standard practices. This warranty covers any defects in workmanship or materials.

How Long Does The Coverage Last? This warranty lasts for 3 months from the date of purchase. Implied warranties of merchantability and fitness for a particular purpose are limited to 3 months from date of purchase. Some jurisdictions do not allow limitations on how long an implied warranty lasts, so the above limitation may not apply to you.

What Does This Warranty Not Cover? This warranty will not apply where the product has been misused, neglected, improperly installed, physically damaged or altered, either internally or externally, or damaged from improper use or use in an unsuitable environment. Xantrex does not warrant uninterrupted operations of its products. Xantrex shall not be liable for damages, whether direct, incidental, special, or consequential, or economic loss even though caused by the negligence or fault of Xantrex. Some jurisdictions do not allow the exclusion or limitation of incidental or consequential damages, so the above limitation or exclusion may not apply to you.

What Will Xantrex Do? At its option, Xantrex will repair or replace the defective product free of charge. Xantrex will, also at its option, use new and/or reconditioned parts made by various manufacturers in performing warranty repair and building replacement products. If Xantrex repairs or replaces a product, its warranty term is not extended. Xantrex owns all parts removed from repaired products.

Service During Warranty. In order to qualify for the warranty, dated proof of purchase must be provided and the product must not be disassembled or modified without prior authorization by Xantrex. If your product requires warranty service, please return it to the place of purchase along with a copy of your dated proof of purchase. If you are unable to contact your merchant, or the merchant is unable to provide service, contact Xantrex directly:

Phone: 604•422•8595
1•800•670•0707

Fax: 604•420•2145
1•800•994•7828

Email: support.jazz@xantrex.com

You must obtain a **Return Material Authorization** (RMA) number from Xantrex before returning a product directly to Xantrex. Do not return a product to Xantrex without first obtaining an **RMA** number. When you contact Xantrex to obtain service, be prepared to supply the serial number of your product and its date of purchase as well as information about the installation or use of the unit.

If you are returning a product from the USA or Canada, follow this procedure:

1. Obtain an **RMA** number and a shipping address from Xantrex. *Product(s) returned without an **RMA** number or shipped collect will be refused.*
2. Package the unit safely, preferably using the original packing materials. Include the RMA number, a copy of your dated proof of purchase, a return address where the repaired unit can be shipped, a contact telephone number, and a brief description of the problem.
3. Ship the unit to the address provided in Step 1, freight prepaid. Obtaining proof of delivery is recommended.

How Other Laws Apply: This warranty gives you specific legal rights, and you may also have other rights which vary from jurisdiction to jurisdiction.

For Our Canadian Customers: When used herein “implied warranties of merchantability and fitness for a particular purpose” includes all warranties and conditions, express or implied, statutory or otherwise, including without limitation implied warranties and conditions of merchantability and fitness for a particular purpose.

6 Out-Of-Warranty Service Information

If the warranty period for your Jazz 300 has expired, if the unit was damaged due to misuse, incorrect installation or if other conditions of the warranty have not been met, or if no dated proof of purchase is available, your unit may be serviced/replaced for a minimum flat fee of \$35.00 US (\$52.50 CDN). To return your Jazz 300 for out of warranty service, contact Xantrex customer service for a Return Material Authorization (RMA) number and follow the other steps outlined in the section “Service During Warranty” above. Options for payment (e.g. credit card or money order) will be explained by the customer service representative. In cases where the minimum flat fee does not apply (e.g. incomplete units or units with excessive damage), an additional fee will be charged. If applicable, you will be contacted by customer service once your unit is received. The minimum flat fee is subject to change without notice.

7 Specifications

| | |
|--|------------------------|
| AC output voltage (nominal) | 110 Vac |
| DC input voltage range | 10–15 Vdc |
| Continuous AC output power | 240 W |
| 30-minute AC output power | 300 W |
| Maximum AC output surge power | 500 W |
| AC output frequency | 60 ± 4 Hz |
| AC output waveform | modified sine wave |
| Battery drain with no AC load (at 12V input) | 0.20 A |
| Efficiency (maximum) | 90% |
| Ambient operating temperature range | 32°F–104°F 0°C–40°C |

| | |
|---|--|
| Low battery alarm trigger point (nominal) | 10.7 V |
| Low battery shut down point (nominal) | 10.0 V |
| High battery shut down point (nominal) | 15 V |
| Dimensions (L x W x H) | 5.1 x 3.7 x 1.9 in 129 x 94 x 49 mm |
| Weight | 1.2 lbs / 550 g |

Specifications subject to change without notice.

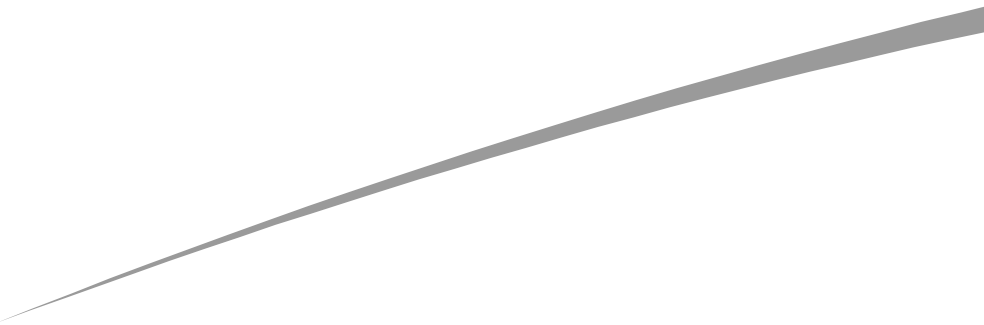

Tel: 604.422.8595
1.800.670.0707

Fax: 604.420.1591
1.800.994.7828

Email: support.jazz@xantrex.com
Web: www.xantrex.com

Free Manuals Download Website

<http://myh66.com>

<http://usermanuals.us>

<http://www.somanuals.com>

<http://www.4manuals.cc>

<http://www.manual-lib.com>

<http://www.404manual.com>

<http://www.luxmanual.com>

<http://aubethermostatmanual.com>

Golf course search by state

<http://golfingnear.com>

Email search by domain

<http://emailbydomain.com>

Auto manuals search

<http://auto.somanuals.com>

TV manuals search

<http://tv.somanuals.com>