



MP3 NG: A Next Generation Consumer Platform

XAPP169 (v1.0) November 24, 1999

Application Note

Summary

This application note illustrates the use of Xilinx Spartan-II FPGA and an IDT RC32364 RISC controller in a handheld, consumer electronics platform. Specifically the target application is an MP3 audio player with advanced user interface features.

In this application the Spartan device is used to implement the complex system level glue logic required to interface and manage the memory and I/O devices. The RC32364 implements the MP3 decoding functions, the graphical user interface, and various device control functions.

Introduction

While the design is targeted at solving a specific problem, decoding and playing compressed audio streams, it illustrates solutions to a number of general technical issues. These include:

- Supporting a graphical user interface in an embedded system.
- Implementing cost-effective interfaces to LCD displays, touch screens, USB, IRDA, and CompactFlash in an embedded system.
- Error handling when using NAND FLASH memory.
- Controlling SDRAM memory.

MP3 Background

MP3 Market

The MP3 player market emerged in late 1998, when Diamond Multimedia shipped its Rio MP3 audio player. While there is considerable diversity in opinions about the potential size of this market, market analysts all agree that the opportunity is significant and will experience rapid growth in the short term. Like any new market, the feature set of MP3 players is likely to change as more users buy them. Key dynamics in this market include:

- **Copy Protection.** While the Secure Digital Music Initiative (SDMI) promises to make a wider variety of music available in MP3 format, there is considerable technical uncertainty about implementation timetables.
- **Non-MP3 Formats.** While MP3 is the dominant format for music available on the Internet, other large players are pushing other formats tailored to their business agendas.
- **Extended Features.** At \$150 to \$250 an MP3 player is a relatively expensive consumer electronics purchase. The dominant component of that price is the FLASH memory that these devices use. This cost component is more or less the same for all vendors, and constrains price point differentiation. One way to increase the perceived value of an MP3 player, and therefore get a competitive advantage, is to add value added features tailored to the target market.

Due to these market dynamics, including the potential for rapid changes in feature requirements, the best approach is a flexible high-performance system. This flexibility manifests itself in two forms. The first is the use of a high-performance processor, which supports the addition of additional soft features without the need to resort to optimized assembly language. The second is the use of a low-cost, high-density FPGA to provide flexible I/O support for the processor.

MP3 Technology

MP3 refers to the MPEG Layer 3 audio compression scheme that was defined as part of the International Standards Organization (ISO) Moving Picture Experts Group (MPEG) audio/video coding standard. MPEG-I defined three encoding schemes, referred to as Layer 1, Layer 2, and Layer 3. Each of these schemes uses increasing sophisticated encoding techniques and gives correspondingly better audio quality at a given bit rate. The three layers are hierarchical, in that a Layer 3 decoder can decode Layer 1, 2, and 3 bitstreams; a Layer 2 decoder can decode Layer 2, and 1 bitstreams; and a Layer 1 decoder can only decode Layer 1 bitstreams. Each of the layers support decoding audio sampled at 48, 44.1, or 32 kHz. MPEG 2 uses the same family of codecs but extends it by adding support for 24, 22.05, or 16 kHz sampling rates as well as more audio channels for surround sound and multilingual applications.

All Layers use the same basic structure. The coding scheme can be described as "perceptual noise shaping" or "perceptual subband / transform coding". The encoder analyzes the spectral components of the audio signal by calculating a filterbank (transform) and applies a psycho-acoustic model to estimate the just noticeable noise-level. In its quantization and coding stage, the encoder tries to allocate the available number of data bits in a way to meet both the bitrate and masking requirements. In plain English, the algorithm exploits the fact that loud sounds mask out the listener's ability to perceive quieter sounds in the same frequency range. The encoder uses this property to remove information from the signal that would not be heard anyway.

Like all of the MPEG compression technologies, the algorithms are designed so that the decoder is much less complex. Its only task is to synthesize an audio signal out of the coded spectral components. All Layers use the same analysis filter bank (polyphase with 32 sub-bands). Layer 3 adds a MDCT transform to increase the frequency resolution.

All layers use the same header information in their bitstream to support the hierarchical structure of the standard.

Solution Overview

A key design objective for this application was the creation of a solution with the lowest possible cost, while at the same time providing support for value added features. These features include the ability to store contact information and record memos and other functions commonly found in Personal Digital Assistants (PDAs).

Figure 1 gives an overview of the design. The key features of which are:

- 128 x 128 pixel graphical touch screen.
- USB interface for download music and network connectivity.
- IRDA compliant infrared interface for exchanging data with other units.
- 32 MB of on board FLASH storage.
- CompactFlash interface for storage expansion using CompactFlash cards or MicroDrive hard drives.

All of this is driven by a high-performance IDT RC32364 32-bit RISC processor and interfaced using a next generation Spartan-II FPGA. Before the functions implemented in the Spartan device and the software function running on the RC32364 are examined, the following gives an overview of the Application Specific Standard Products (ASSPs) that are included in the design.

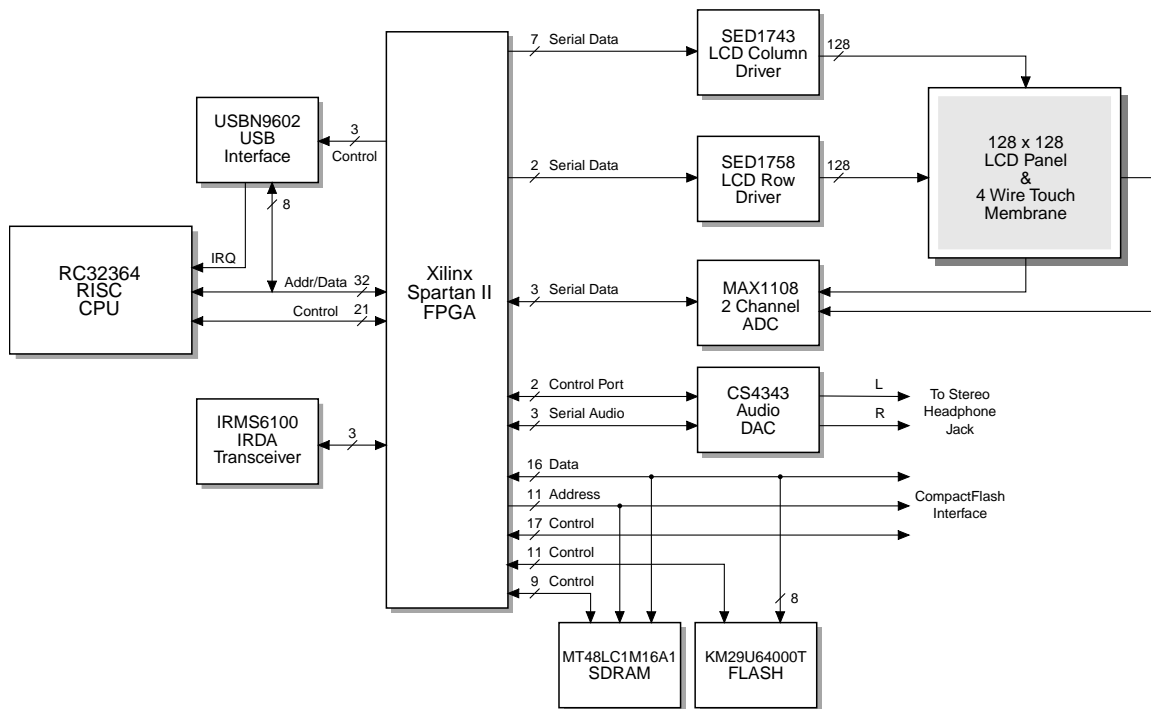

Figure 1: MP3 NG System Block Diagram

IDT RC32364 RISController™

The processor chosen for this design is the IDT RC32364. The features of this device that are leveraged in this application are:

- Paged memory management unit.
- High-performance, 175 dhrystone MIPs at 133 MHz.
- Integer Multiply ACcumulate (MAC) support, 67M MACs/second at 133 MHz.
- Separate, line lockable, instruction (8 KB) and data (2 KB) caches.
- Power saving features including active power management and a power-down operating mode.
- On-chip In Circuit Emulation (ICE) interface to provide access to internal CPU state (registers, cache) and for debug control (breakpoints, single step, insert instructions into pipeline).

Figure 2 shows the block diagram for this device. The complete data sheet for the RC32364 can be found at the following URL:

http://www.idt.com/docs/79RC32364_DS_32100.pdf

The RC32364's MMU consists of address translation logic and a Translation Lookaside Buffer (TLB) capable of supporting demand paged virtual memory. In addition, it includes several features that are valuable in an embedded application such as variable sized pages and lockable TLB entries. Figure 3 illustrates the virtual to physical address translation performed by the RC32364.

The variable page size lets each mapping independently represent memory regions that can range from 4 KB to 16 MB. This feature lets the system designer adjust the address mapping granularity for different memory regions.

Locking TLB entries excludes entries from being recommended for replacement when there is an address miss. This lets the system designer have mappings for critical regions of code and or data locked into the TLB for predictable real time performance.

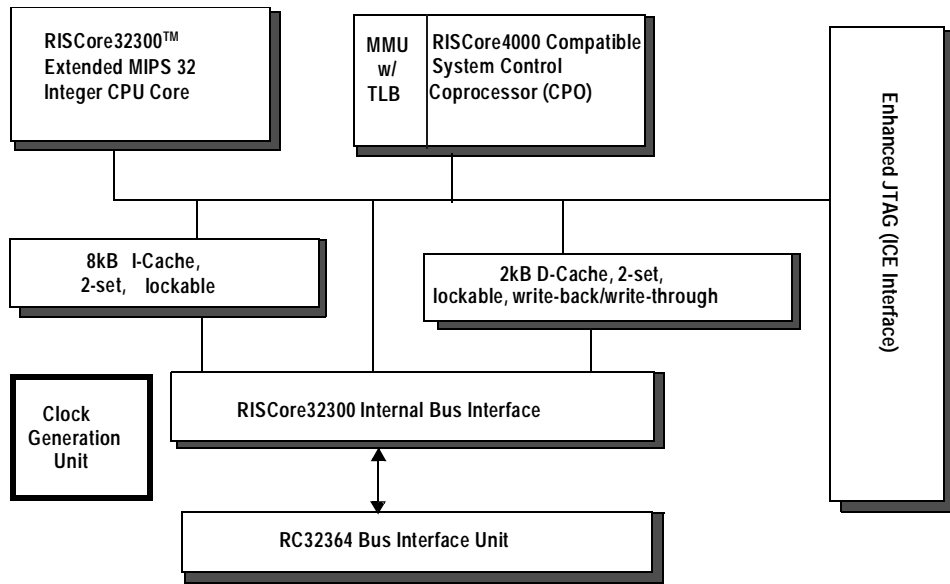

Figure 2: RC32364 Block Diagram
(Courtesy IDT)

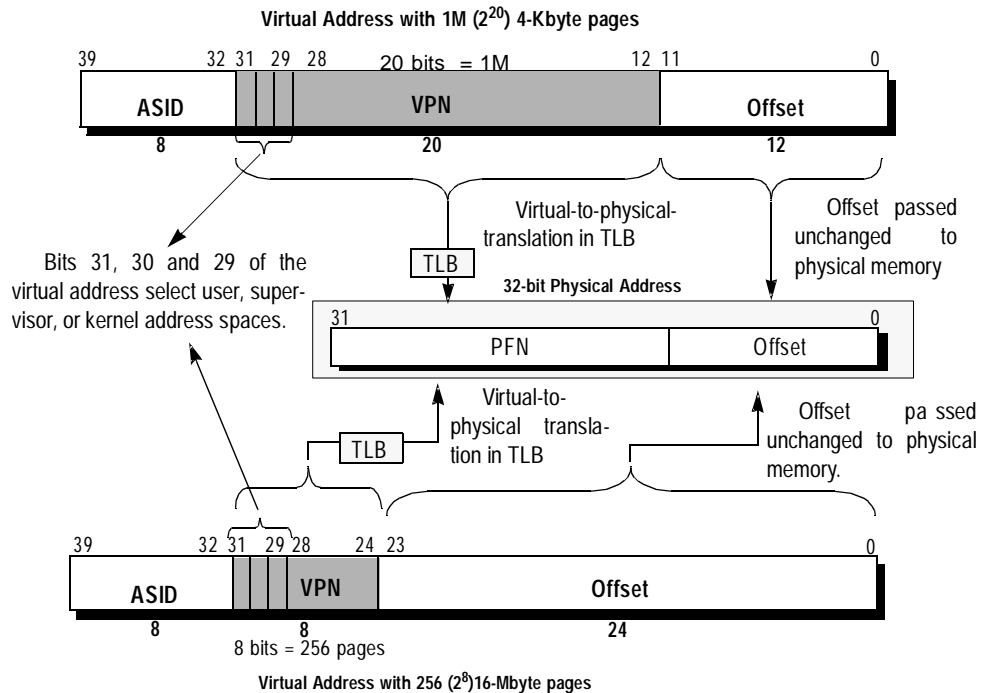

Figure 3: RC32364 Address Translation
(Courtesy IDT)

The RC32364 interfaces to the system through a 32-bit multiplexed address/data bus. The bus offers a rich set of signals to control transfers of which only a subset was required for this application. [Figure 4](#) shows the timing for read transactions on this bus.

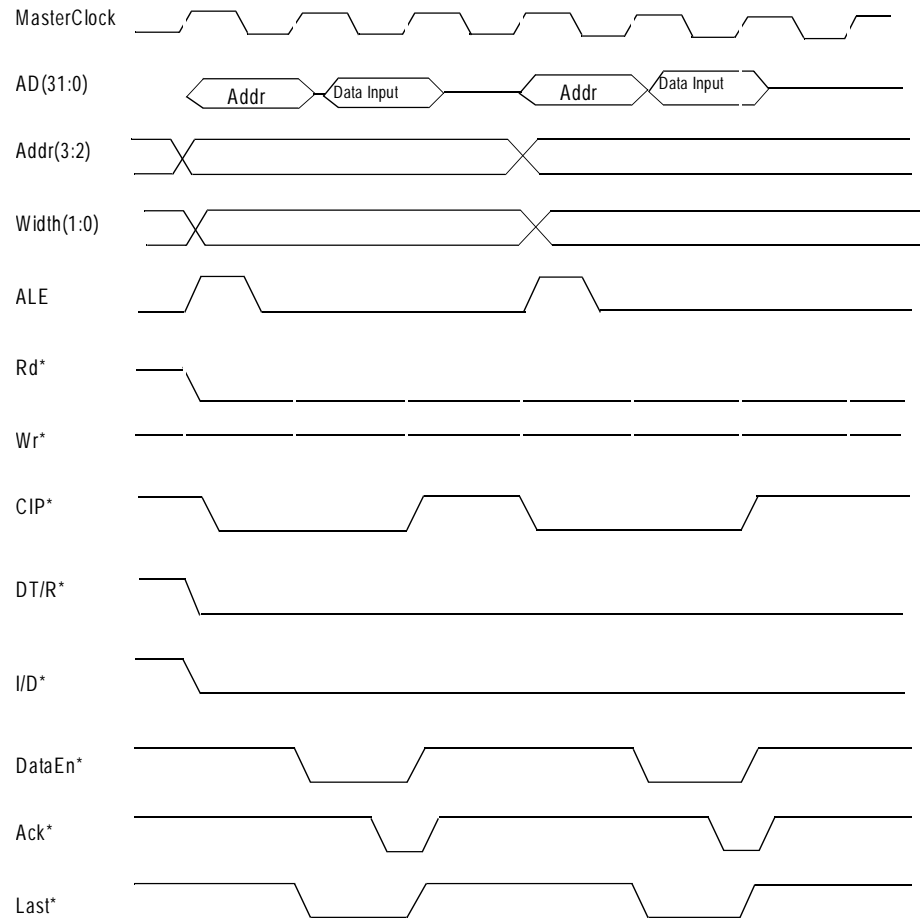

Figure 4: RC32364 Read Timing
(Courtesy IDT)

Crystal CS4343 Stereo DAC

The Digital-to-Analog Converter chosen for this design is the Crystal CS4343 from Cirrus Logic. This device features:

- 1.8V to 3.3V operation.
- 24-bit conversion at up to 96 kHz.
- Digital volume control.
- Digital bass and treble boost.
- Built-in headphone amplifier capable of delivering 5 mW into a 16 Ω load.

Figure 5 shows the block diagram for this device.

The CS4343 provides three interfaces: the analog stereo headphone interface, the serial port used to transfer digital audio data streams, and the control port used to configure the device.

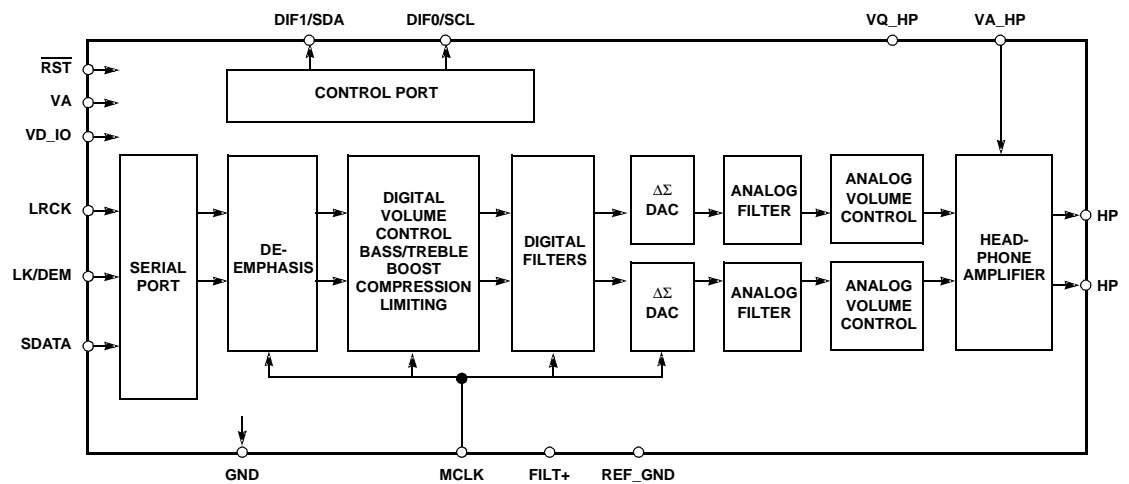

Figure 5: CS4343 Block Diagram
(Courtesy Cirrus Logic)

The control port is an industry standard I²C slave interface. I²C is a multidrop, 2-wire, serial interface consisting of a clock (SCL) and data (SDA) and operating at up to 100 kHz. (See Figure 7 Control Port Timing.) The control port is used to configure device features such as volume, muting, equalization, power management, and the operating mode of the serial port. Figure 1 on page 3 gives an overview of control port timing. A detailed description of I²C operation can be found in the I²C specification as described in the references.

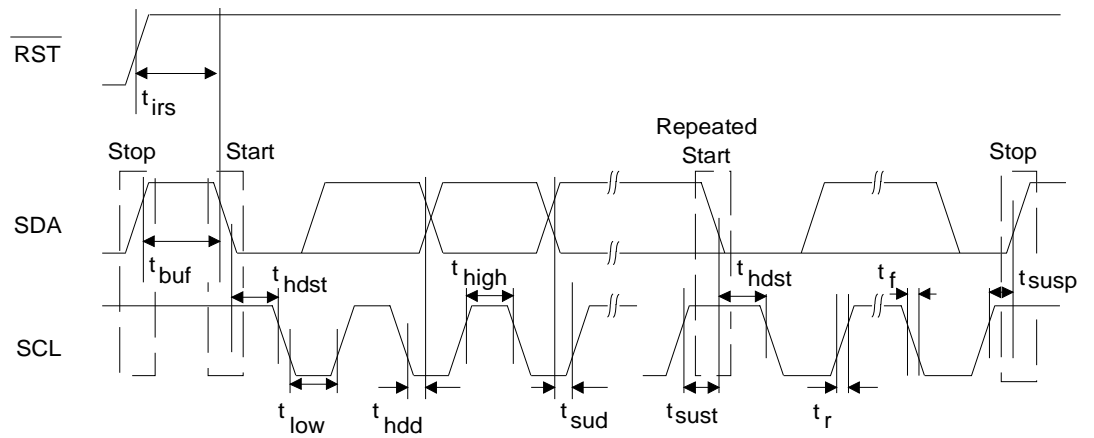

Figure 6: Control Port Timing
(Courtesy Cirrus Logic)

The serial port can be configured for several operating modes. The mode of operation chosen for this application is referred to in the CS4343 documentation as "Serial Audio Format 2". [Figure 7](#) gives an overview of serial port timing when in this mode.

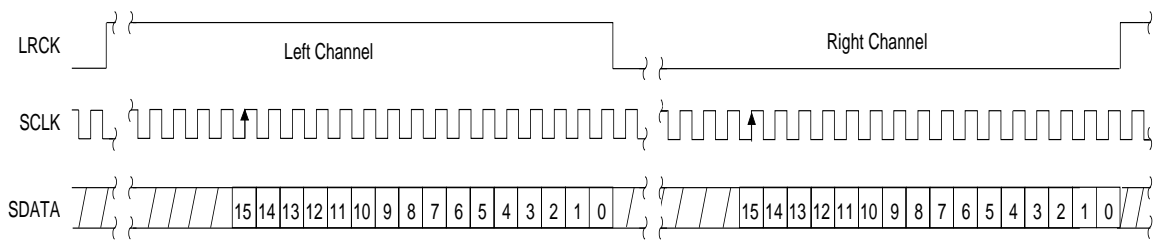

Figure 7: Serial Port Timing
(Courtesy Cirrus Logic)

Samsung FLASH Memory

The FLASH memory chosen for this design is the KM29U64000T 8M x 8 device from Samsung Semiconductor. This device is based on NAND FLASH technology and is popular in MP3 player applications due to its high density and low cost per bit.

Figure 8 shows the block diagram for this device. The complete data sheet for the KM29U64000T can be found at the following URL:

[http://www.usa.samsungsemi.com/products/prodspec/flash/km29u64000\(i\)t.pdf](http://www.usa.samsungsemi.com/products/prodspec/flash/km29u64000(i)t.pdf)

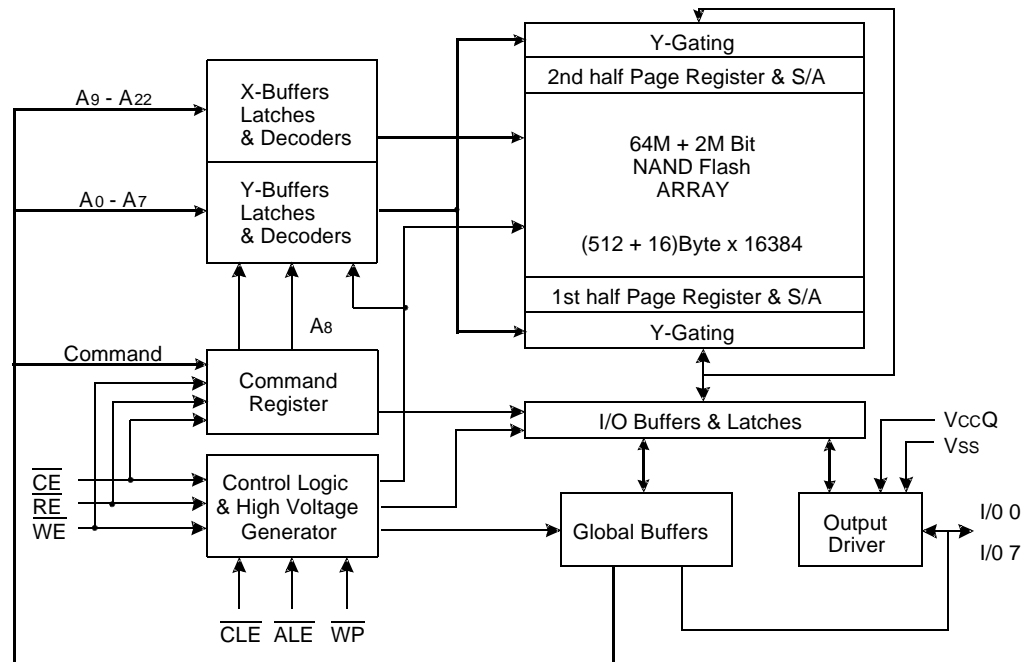

Figure 8: KM29U64000T Block Diagram
(Courtesy Samsung Semiconductor)

Unfortunately this device also has two characteristics that present significant system level design challenges. The first of these is the narrow, highly multiplexed interface that is used to access the device. The KM29U64000T interfaces to the system through an 8-bit wide port that is used for both address and data. Figure 9 illustrates the read timing for this device.

The second and most challenging issue relates to data integrity, which is an issue common to most devices using NAND technology. There are two aspects to this, the first of which is the fact that devices when shipped may have memory blocks that may not be used due to data errors. The data sheet for the device has a parameter called N_{VB} that is the number valid blocks that the device contains. The value of N_{VB} varies from device to device and is specified to have a minimum of 1014, a maximum of 1024, and typically 1020. While the first block is guaranteed to be good, bad blocks can occur at any other location within the memory array. Invalid blocks are marked at the factory by storing a "0" value at location "0" in either the first or second block of the page. The system level impact of this is that it must keep track of which blocks are good within the device and that this results in a non-contiguous memory map.

The second issue is that while the device is guaranteed to provide at least the minimum number of valid blocks over its operational lifetime these devices may experience failures in additional blocks throughout their life. In order to ensure system integrity some form of error detection and correction must be implemented.

The discussion of the FLASH memory interface will discuss how these issues were addressed in this design.

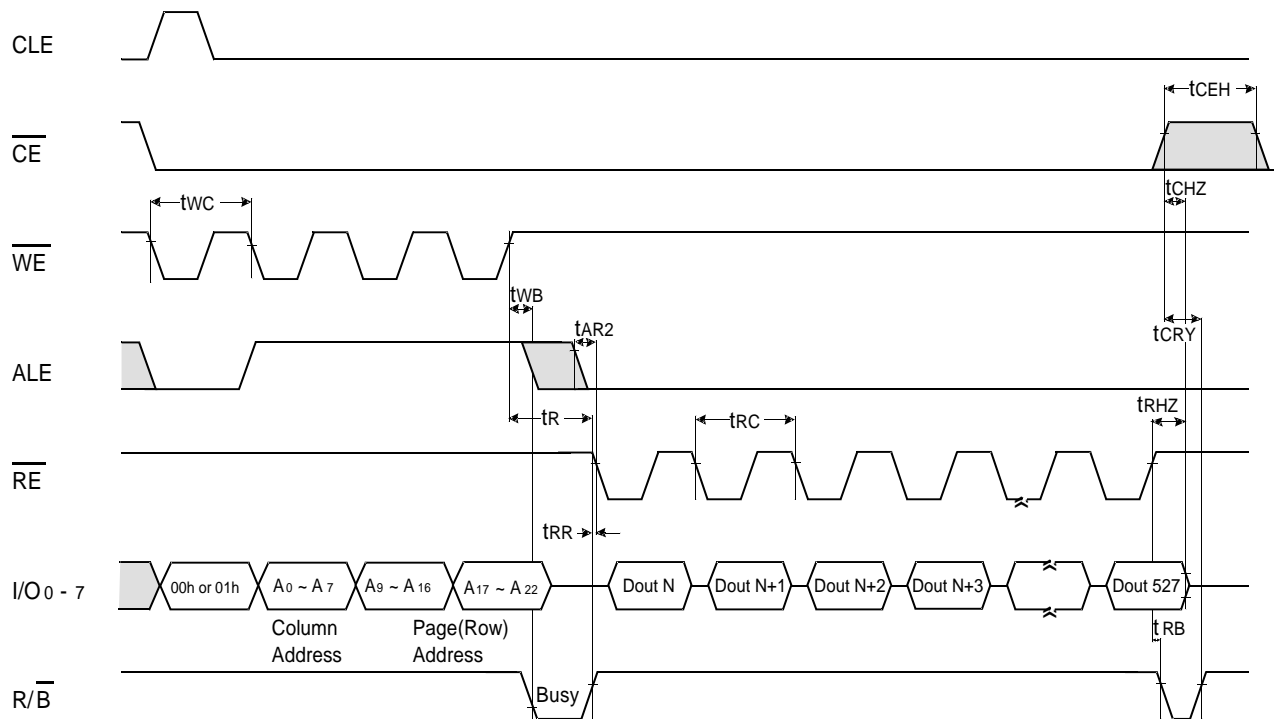

Figure 9: KM29U64000T Read Timing
(Courtesy Samsung Semiconductor)

Micron SDRAM Memory

The SDRAM memory chosen for this design is the MT48LC1M16A1S - 512K x 16 x 2 bank device from Micron Semiconductor. This device is available in speed grades from 125 to 166 MHz operating over an LVTTTL synchronous interface. [Figure 10](#) shows the block diagram for this device. [Figure 11](#) shows the MT48LC1M16A1 read timing of the device. The complete data sheet for the MT48LC1M16 can be found at the following URL:

<http://www.micron.com/mti/msp/pdf/datasheets/16MSDRAMx16.pdf>

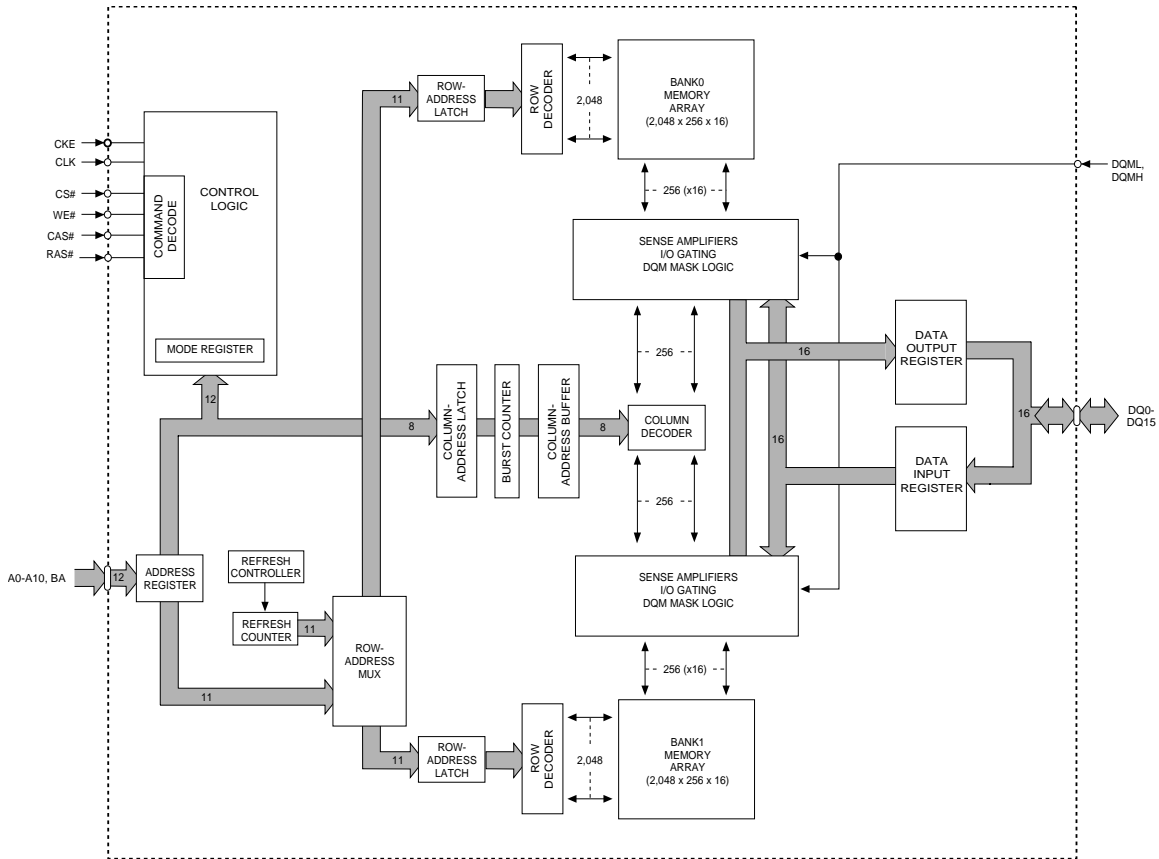

Figure 10: MT48LC1M16A1 Block Diagram
(Courtesy of Micron Technology, Inc.)

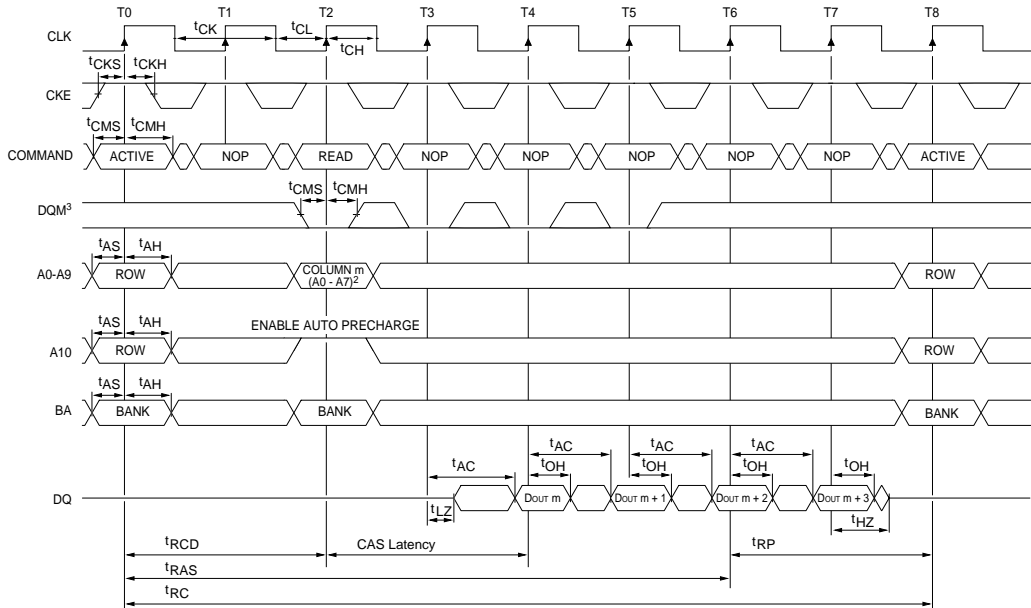

Figure 11: MT48LC1M16A1 Read Timing
(Courtesy of Micron Technology, Inc.)

National Semiconductor USBN9602 USB Function Controller

The USB interface in the design is based on a National Semiconductor USBN9602 controller. This device, packaged in a 28-pin SOIC package, supports full speed USB function controller operation and includes an integrated USB transceiver. It contains seven endpoint FIFOs, two of which are 64 bytes deep.

Figure 12 shows a block diagram of this device. The complete data sheet for the USBN9602 can be found at the following URL:

<http://www.national.com/ds/US/USBN9602.pdf>

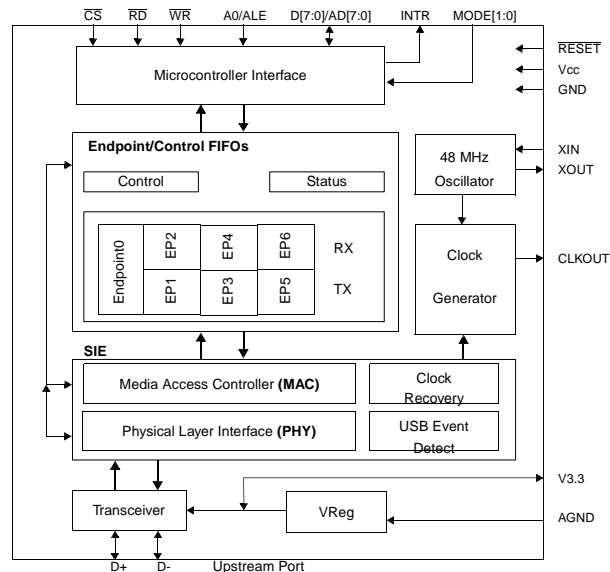

Figure 12: USBN9602 Block Diagram
(Courtesy National Semiconductor)

The system interface for the USBN9602 is a simple 8-bit microprocessor bus that can be configured to operate in a multiplexed or non-multiplexed mode. The multiplexed mode is more attractive from a software perspective since it supports random access to the devices' internal registers. This mode also reduces the number of interface pins required. For both of these reasons this was chosen for this application. Figure 13 shows read timing for the USBN9602 when operating in multiplexed mode.

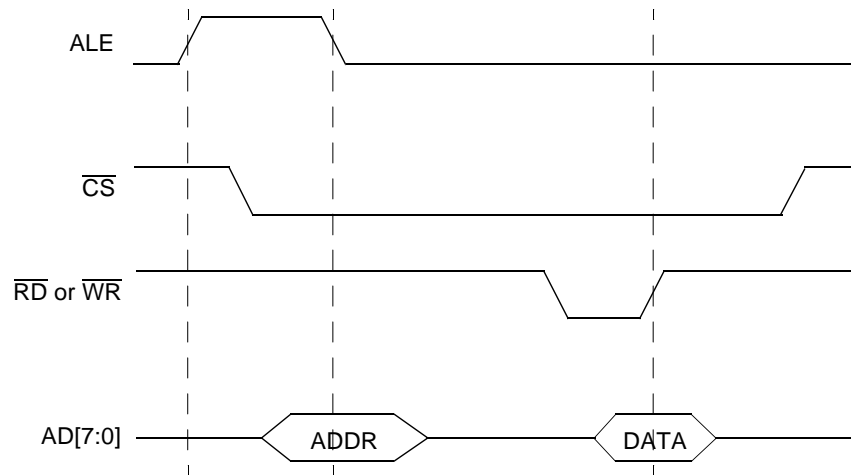

Figure 13: USBN9602 Read / Write Cycle Timing
(Courtesy National Semiconductor)

System Implementation

This section describes how all of these pieces are integrated into a complete system. First described is the software architecture and the functionality of the key modules. Next is the architecture and implementation of the logic contained in the Spartan-II FPGA.

Software Architecture

The system software required to implement this device is shown in [Figure 14](#). The software components fall into four categories:

- **RTOS.** A Real Time Operating System is included in the software architecture in order to simplify the management of resources and concurrent activities.
- **BIOS.** The Basic Input Output System functions provide low level device management functions and hardware abstraction.
- **Protocol Stacks.** These modules implement the network protocol layers for the communications interfaces.
- **Management Processes.** These modules implement the application levels functions, and these run as processes under the RTOS.

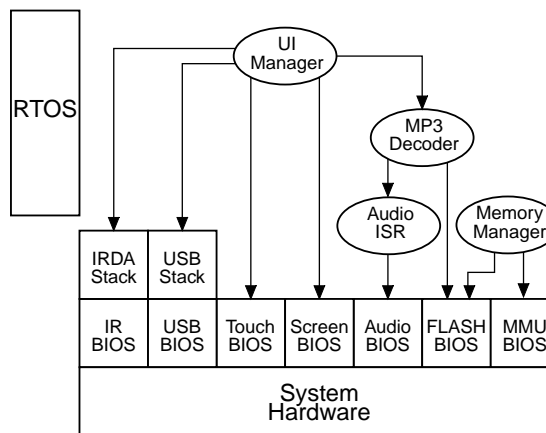

Figure 14: System Software Architecture

The RTOS provides process scheduling and memory allocation functions. The RTOS could be any of the commercially available packages. Probably more of a factor than any technical issue is the licensing model for the product. Since this is a product that is targeted at the high-volume, cost sensitive, consumer market, an RTOS that is licensed on an up front fee basis with no unit royalties is the most attractive.

The various BIOS components will be discussed later in the sections that describe the hardware implementation for each interface. The key application modules are as follows:

UI Manager

The User Interface (UI) manager is responsible for handling interaction between the user and the system. This includes using the Screen BIOS to create the buttons and menus that the user sees, getting user input through the Touch BIOS and using this information to coordinate activities such as downloading and playing MP3 files. The UI manager would also spawn separate processes for value added features such as an appointment calendar, or a phone book, as needed.

MP3 Decoder and Audio ISR

The MP3 decoder runs as an independent process, controlled by the UI manager. When activated, it uses the FLASH BIOS to fetch MP3 file data, decompresses it and places the audio data in a queue. The audio Interrupt Service Routine (ISR) is activated by an interrupt from the Audio DAC block in the FPGA. When activated, it reads data from this queue and writes it to FIFOs in the Audio DAC block.

The key to getting optimal performance from the MP3 decoder on the RC32364 lies in taking advantage of the MAC instruction supported by the processor. The instruction is particularly valuable in the implementation of the Discrete Cosine Transform (DCT) for sub-band synthesis.

There are several sources for MP3 decoder code. A fixed point decoder (`splay-0.81-fixpoint.tgz`) that was developed for the Linux ARM project can be downloaded from the following URL:

<ftp://ftp.netwinder.org/users/n/nico>

The reference code that was developed for the standard is available from the Fraunhofer Institute at the following URL:

<http://www.iis.fhg.de/amm/techinf/layer3/index.html>

A commercial decoder is available from Xaudio. Information on the Xaudio product line is available from:

<http://www.xaudio.com>

Memory Manager

The Memory Manager handles the tasks required to mask NAND FLASH issues from the other software in the system. Specifically these tasks are block mapping and code initialization.

Block Mapping

This involves maintaining a table of valid FLASH blocks and configuring the MMU to map them into a linear address space. For the FLASH memory space the TLB entries are set to the same 8 KB size to match the block size of the FLASH itself, and the entries are not locked in the TLB. A single TLB entry is used to map the SDRAM memory space. This entry is configured to map a 4 MB memory space and is locked in the TLB.

In the event that an error is detected in a valid block, this code is also responsible for copying the data to an unused block and marking the block in which the error was detected as bad.

Code Initialization

This function copies the code image from FLASH to RAM at boot time. This routine must also perform error detection on the image as it is copied. If an error is detected, error correction must be performed and the block mapping code informed.

Xilinx Spartan- II FPGA

Figure 15 shows the architecture implemented in the Spartan-II device for this application. It consists of eight major functional blocks:

- IP Bus Controller
- CPU Interface
- LCD Controller
- Memory Datapath
- SDRAM Controller
- FLASH Controller
- CompactFlash Controller
- IRDA Controller
- DAC Interface
- Touch Screen Interface

These blocks are interconnected by a simple non-multiplexed, multi-master, address data bus that is referred to as the IP bus. While the IP bus may appear to be a bus to the function blocks, it is not a bus at all but instead uses multiplexers for gating data into the internal datapaths. This approach eliminates the need for 3-state drivers within the design. In this implementation the bus has two masters; the CPU Interface and the LCD Controller. **Figure 15** shows a top level block diagram of the FPGA.

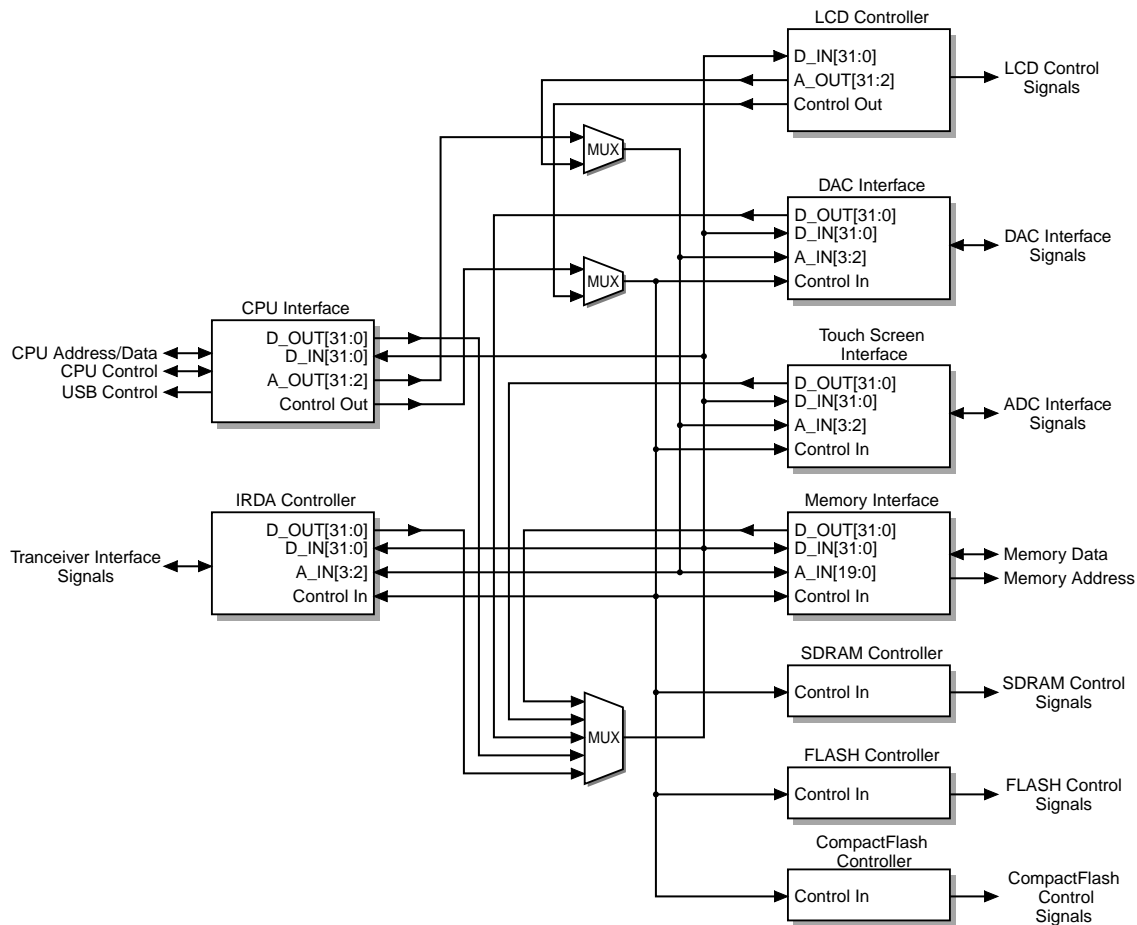

Figure 15: FPGA Logic Block Diagram

While most of the blocks are fairly independent, the FLASH, SDRAM, and CompactFlash interfaces share common address and data busses. While this results in a fairly complex muxing scheme for these datapaths it is necessary to keep the pin count within an acceptable range.

The following sections will discuss the implementation of each of these functional blocks and outline the hardware and software resources needed to support each.

IP Bus Controller

The IP Bus Controller block performs two functions: block address decoding and IP bus arbitration.

The address decode block generates device selects for the IP block that is the target of the transfer. It also controls the multiplexers that select the response signals from the target of the transfer (ACK, DOUT, etc.).

IP bus arbitration between access requests from the CPU Interface and the LCD Controller are handled by using a simple rotating priority scheme. The arbiter block also controls the multiplexers that select which set of transfer control signals (RD, WR, etc.) control the transfer.

The FPGA device resources used to implement this block include an estimated 32 CLBs but no I/O pads. There is no software required to support this block.

CPU Interface

The CPU Interface block performs three functions: protocol conversion, CPU initialization and address de-multiplexing. Figure 16 shows a block diagram of this block.

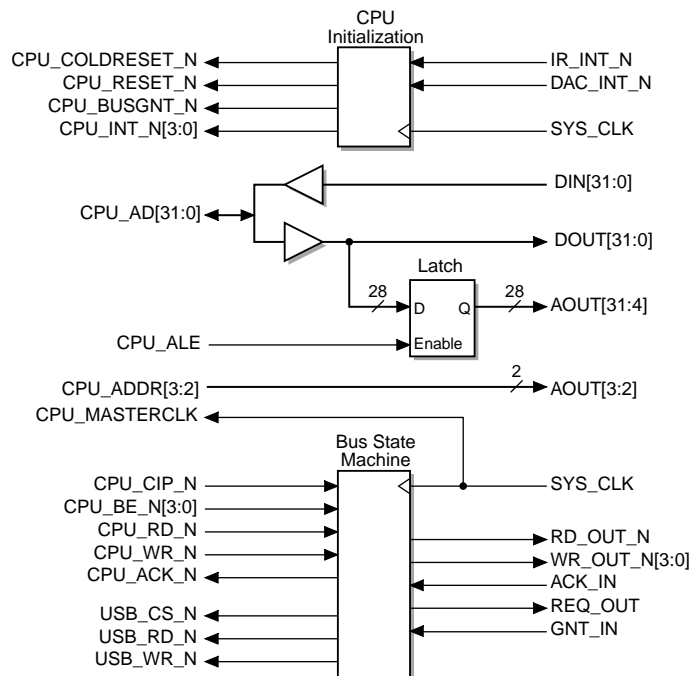

Figure 16: CPU Interface Block Diagram

The CPU initialization block generates the required timing for the reset signals and drives configuration information onto bus grant and the interrupts. This configuration information configures the boot PROM width and enables the CPU timer. After initialization is complete the block drives the IRDA and audio DAC interrupts out onto the CPU interrupt signals.

The bus state machine converts the signaling on the CPU bus into the format used on the local IP bus, or if the transaction is to the USB interface, the signaling accepted by the USBN9602.

The FPGA device resources used to implement this block include an estimated 46 CLBs and the 54 I/O pads listed in Table 1.

Table 1: CPU Interface Signal Summary

Signal	Type	Description
CPU_MASTERCLK	Output	All bus timing is relative to this clock. The CPU core frequency is derived by multiplying this clock.
CPU_AD[31:0]	I/O	High-order multiplexed address and data bits.
CPU_ADDR[3:2]	Input	Non-multiplexed address lines. These serve as the word within block address for cache refills (Addr[3:2]).
CPU_BE_N[3:0]	Input	Indicates which byte lanes are expected to participate in the transfer.
CPU_ALE	Input	Address latch enable.
CPU_CIP_N	Input	Denotes that a cycle is in progress. Asserted in the address phase and is asserted until the ACK* for the last data is sampled.
CPU_RD_N	Input	This active Low signal indicates that the current transaction is a read.
CPU_WR_N	Input	This active Low signal indicates that the current cycle transaction is a write.
CPU_BUSGNT_N	Output	During the power-on reset (Cold Reset), BusGnt* is an input and is used to load ModeBit(5).
CPU_ACK_N	Output	On read transactions, this signals the RC32364 that the memory system has placed valid data on the A/D bus, and that the processor may move the data into the on-chip Read Buffer. On a write transaction, this signals to the RC32364 that the memory system has accepted the data on the A/D bus.
CPU_RESET_N	Output	This active Low signal is used for both power-on and warm reset.
CPU_COLDRESET_N	Output	This active Low signal is used for power-on reset.
CPU_INT_N[3:0]	Output	Active Low interrupt signals to the CPU. During power-on, Int* (3:0) serves as ModeBit (9:6).
US_CS_N	Output	USB controller chip select.
US_RD_N	Output	USB controller read strobe.
US_WR_N	Output	USB controller write strobe.

There is no direct software support required for this block, but the USB interface itself requires considerable software for operation. This software consists of the USB protocol stack, which includes a USB interrupt service routine. The USB stack itself consists of two parts. The first of these is the software required for participating in the USB protocol and the plug and play. The second part is the application specific code required to transfers MP3 files from the host system to the player.

LCD Controller

The LCD Controller is responsible for refreshing the screen with an image stored in the SDRAM. In general its operation is similar to that of a CRT display controller. Unlike most display controllers, the display format generated by the LCD controllers is not programmable by the CPU. The raster format is fixed at 128 x 128 pixels and the display timing is fixed as well. This makes sense in an embedded system such as this where the display is integrated into the unit. Although the display format cannot be changed in the system, loading different FPGA configurations into the FLASH when the unit is manufactured can accommodate different displays. [Figure 17](#) shows the block diagram of the LCD Controller.

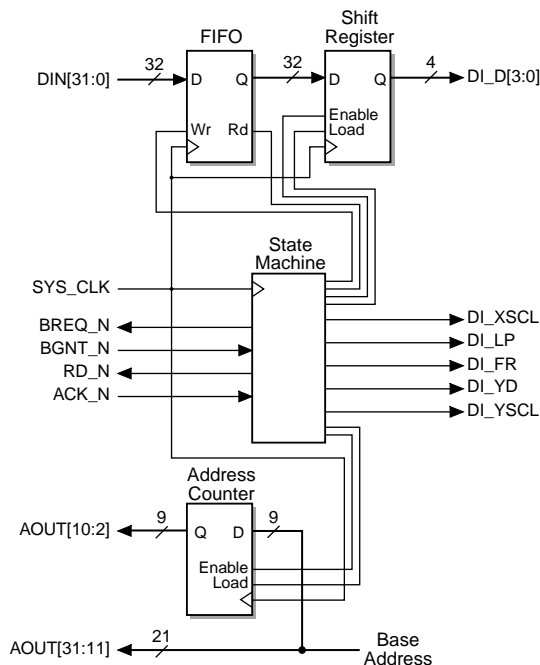

Figure 17: LCD Controller Block Diagram

The LCD Controller is an IP bus master and fetches data for screen refresh independently of CPU activities. The display data that is fetched is loaded into a FIFO using a block transfer across the IP bus. The shift register loads display data from the FIFO and shifts it out as a 4-bit wide data stream at 16 MHz the maximum shift rate supported by the display drivers.

In order to prevent disruption of the display image, the FIFO must have a new data word available for the shift register every time it empties. This occurs every 500 ns ($1 / [16 \text{ MHz} / 8]$). Since there is a significant amount of overhead associated with each non-sequential access to the SDRAM memory, fetches are made from it using multi-word bursts. The size of these bursts is a compromise between different factors. Longer bursts are more efficient since the SDRAM access overhead is amortized over a larger number of data words. Smaller bursts reduce the size of the FIFO and also reduce bus latency by reducing the time that the LCD controller ties up the IP bus. For this application a 2-word burst was chosen. The result is a 3-word deep FIFO and display buffer fetches every 1 μ s.

The FPGA device resources used to implement this block include an estimated 58 CLBs and the nine I/O pads listed in [Table 2](#).

Table 2: LCD Controller Interface Signal Summary

Signal	Type	Description
DI_XD[3:0]	Output	X driver data
DI_XSCL	Output	X driver data shift clock
DI_LP	Output	Latch pulse
DI_FR	Output	Frame signal
DI_YD	Output	Y driver scan start pulse
DI_YSCL	Output	Y driver shift clock

The only software support required for this block is the screen BIOS which consists of functions to generate screen images by manipulating the frame buffer memory. This buffer appears as an array of 512, 32-bit words with each word containing 32 pixels of the screen image. The most significant bit of the word at the base address appears as the pixel in the upper left-hand corner of the screen. The least significant bit of that memory word appears as the 32nd pixel in the first row. The word and bit address of any pixel on the screen can be calculated using the following formula:

$$\begin{aligned} \text{Memory Address} &= X * Y \text{ MOD } 32 \\ \text{Bit Address} &= X * Y \text{ REM } 32 \end{aligned}$$

Where:

X and Y are the horizontal and vertical coordinates of the screen and assume that the origin (X = 0, Y = 0) is in the upper left-hand corner of the screen.
 MOD the integer division.
 REM is the remainder of the division

Memory Interface

The memory interface block, [Figure 18](#) implements the data path required to map the 8- and 16-bit memory devices to the 32-bit IP bus. While the RC32364 is capable of fetching instructions and data from devices with varying bus widths, having the FPGA build 32-bit words for the CPU reduces the number of bus cycles. This increases performance and also reduces power consumption. [Figure 16 on page 16](#) shows a block diagram of this block.

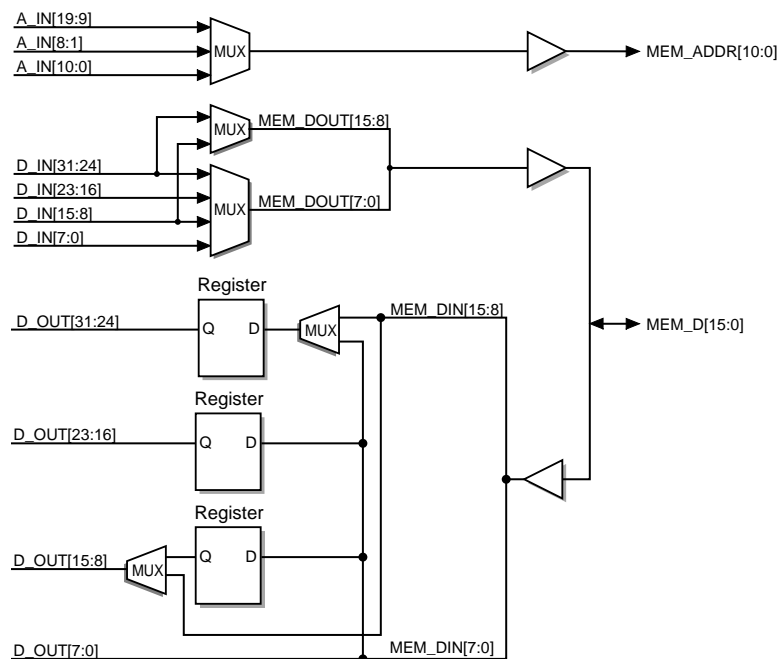

Figure 18: Memory Interface Block Diagram

SDRAM Controller

The SDRAM controller design (Figure 19) is based on the design developed by Xilinx in application note *XAPP134: Virtex Synthesizable High Performance SDRAM Controller*. The changes made in the original design are to adapt to the differences in the host interface. In the original design the host interface is a multiplexed address data bus. In this application the IP bus is non-multiplexed. Another difference is that the original design supported a 32-bit wide memory configuration with two MT48LC1M16 memory devices. In the design a 16-bit wide memory datapath and a single MT48LC1M16 is used.

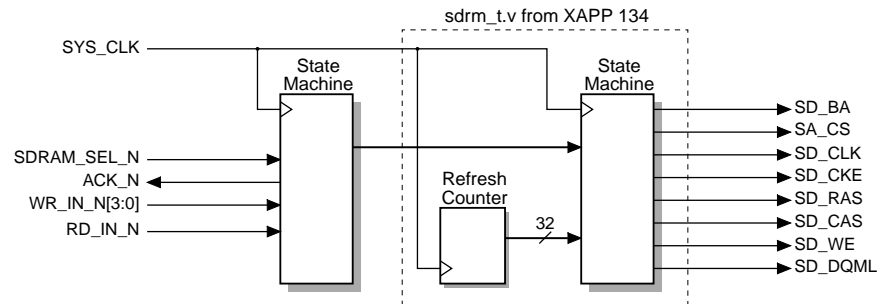

Figure 19: Figure 19 SDRAM Controller Block Diagram

The estimated FPGA device resources used to implement this block include an estimated 100 CLBs, two DLLs, two global clock buffers and the nine I/O pads listed in Table 3. There is no software support required for this block.

Table 3: SDRAM Controller Interface Signal Summary

Signal	Type	Description
SD_BA	Output	Bank address
SD_CS	Output	Chip select
SD_CLK	Output	Transfer clock
SD_CKE	Output	Clock enable
SD_RAS	Output	Row address strobe
SD_CAS	Output	Column address strobe
SD_WE	Output	Write enable
SD_DQML	Output	Lower byte data mask
SD_DQMH	Output	Higher byte data mask

FLASH Controller

The largest cost associated with this design is the large amount of FLASH memory, 32 MB or more, that is required for storing MP3 audio files. In order to leverage this cost it is desirable to use this memory for all non-volatile storage requirements within the system. This includes code storage for the CPU as well as storage of the MP3 audio stream. (See Figure 20.)

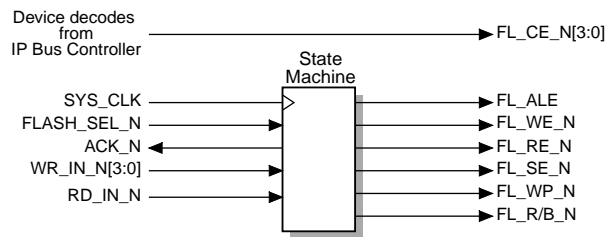

Figure 20: FLASH Controller Block Diagram

When the architecture for this system was being planned, one issue that needed to be addressed was whether to execute the program image directly from FLASH or to copy it to SDRAM. There were two key issues that needed to be considered when making this decision.

Performance

The narrow, 8-bit, interface used for both address and data is one performance issue, but it is not the biggest. The real problem is random access latency. Within a 512-byte memory page, data can be read with a 50 ns read cycle time. The problem comes when the processor accesses data on a different page. The time required to load a page into the page register, where it can be accessed, is 7 μ s. With a 66 MHz processor frequency this represents 462 instruction times. This latency will adversely effect real-time performance.

Error Handling

Each 512-byte page in the FLASH has 16 bytes of spare storage for storing ECC information. The problem is that this is not enough storage for implementing ECC for small block sizes. For example, to correct single bit errors on an RC32364 cache line (16 bytes) using a Hamming code the following relationship must be satisfied:

$$N \leq 2^{K-1} - K - 1$$

where: N is the number of data bits in the block
K is the number of ECC bits

Solving for K:

$$16 * 8 = 256 \leq 2^K - K - 1$$

$$K = 9 \text{ ECC bits per cache line}$$

Since there are 32 (512/16) cache lines per page, a total of 36 bytes are needed for ECC storage. Recall that 16 bytes are available.

In order to get around this problem, the block size could be increased to 32 bytes. At 32 bytes, ten bits of ECC are required per block, but there are now only 16 blocks per page which is consistent with the available ECC memory per page. Performing the block check over two cache lines could accommodate this larger block size. The down side to this is that every time a cache line is loaded, two would have to be checked with a corresponding increase in memory latency.

As a result of this the decision was made to copy the executable image to the SDRAM memory at boot time. This not only increases performance but also turns the ECC checking issue into a non real-time software exercise.

The estimated FPGA device resources used to implement this block include an estimated 100 CLBs, and the ten I/O pads listed in [Table 4](#).

Table 4: FLASH Controller Interface Signal Summary

Signal	Type	Description
FL_CE_N[3:0]	Output	Device chip enables, active Low.
FL_ALE	Output	Address latch enable.
FL_WE_N	Output	Write enable, write data is latched on the rising edge.
FL_RE_N	Output	Read enable, when Low enables device data output buffers.
FL_SE_N	Output	Enable spare area when Low.
FL_WP_N	Output	Write protect, active Low.
FL_R/B_N	Input	Open drain output from devices, pulled Low when a program, erase, or read operation is in progress.

Software support required for this block consists of the FLASH BIOS which implements low level primitives for programming, erasing, and checking validity of memory blocks.

IRDA Controller

The IRDA controller is essentially a specialized, fixed function UART. The separate, 2-word, transmit and receive FIFOs reduce the interrupt overhead associated with data transmission. At the maximum data rate that the IR transceiver can support (115 kb/s) the CPU will get an interrupt every 557 ms. (See [Figure 21](#).)

**Figure 21: IRDA Controller Block Diagram**

Table 5: Table 5 IRDA Transceiver Interface Signal Summary

Signal	Type	Description
IR_TXD	Output	Transmit data
IR_RXD	Input	Receive data
IR_SD	Output	Shut down signal, puts transceiver into low power mode

Audio DAC Interface

The interface for the CS4343 consists of two separate functional blocks, one for each of the serial interfaces that are required to support this device. Figure 22 shows a block diagram of this interface.

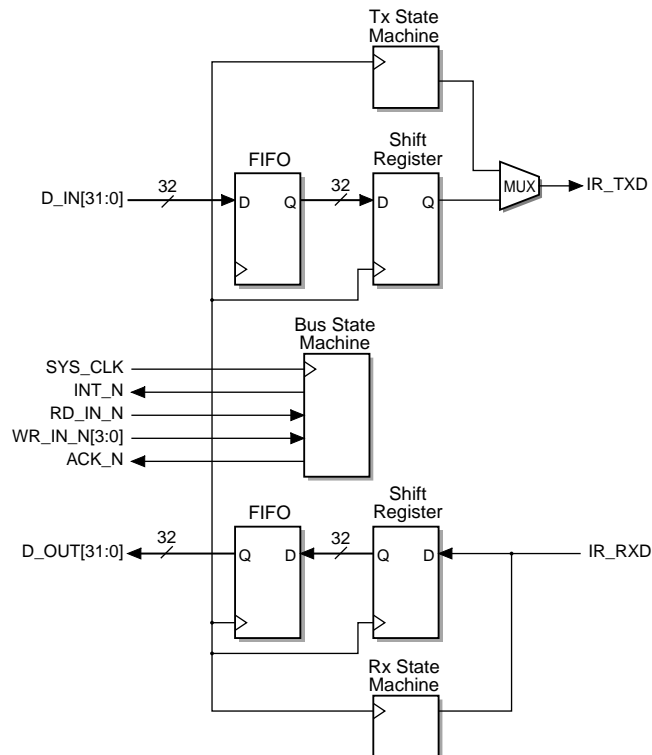
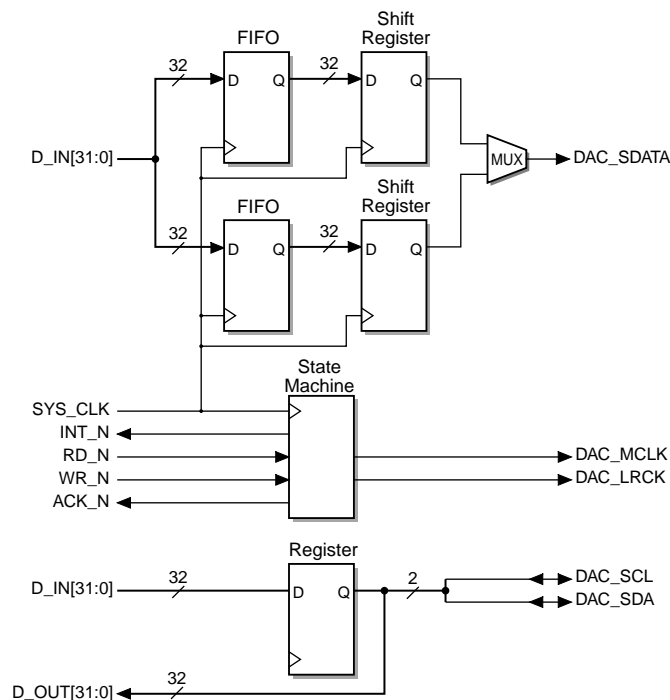
**Figure 22: Audio DAC Interface Block Diagram**

The control port interface is implemented as a 2-bit I/O port that is manipulated by software in order to implement the I²C protocol used for accessing the control and status registers in the DAC. This approach uses minimal device resources and is practical due to the low data rate of this port and its infrequent use.

When the system is in operation, the serial audio port is in use most of the time. Therefore, dedicated hardware is provided for implementing the transfer protocol and for delivering an uninterrupted audio stream. This hardware consists of two, 4-word FIFOs, one for each audio channel and a state machine to manage the FIFOs and sequence the interface signals.

Like the IRDA controller, an interrupt is generated every time the FIFOs transfer their last word into the shift registers. Assuming a 48 kHz audio sampling rate, this will result in an interrupt every 83.3 μ s. To put this in perspective, this means that the CPU will get an interrupt every 5,333 instructions.

Table 6: Audio DAC Interface Signal Summary

Signal	Type	Description
DAC_MCLK	Output	Master clock
DAC_LRCK	Output	Left / Right clock, determines which channel is currently being transferred
DAC_SDATA	Output	Serial audio data
DAC_SCL	Output	I ² C data clock
DAC_SDA	I/O	I ² C data

Touch Screen Interface

The touch screen interface is an I/O port that lets the processor read the data returned by a two-channel analog-to-digital converter. This lets the system software read the X and Y coordinate resistance values that result from the user touching the screen. The system software handles linearization and filters out transient touch events. (See [Figure 23](#) and [Table 7](#).)

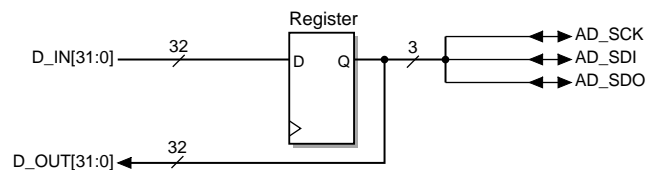

Figure 23: Touch Interface Block Diagram

Table 7: Touch Screen Interface Signal Summary

Signal	Type	Description
AD_SCK	Output	Serial data clock
AD_SDI	Input	Serial data in
AD_SDO	Output	Serial data out

Spartan Device Selection

Spartan devices are available in a range of densities and packages. The following criteria were used to select the device used in this application:

- **I/O Pins.** The design requires a total of 137 I/O pins. I/O pin requirements per block are summarized in FPGA Resource Usage Summary.
- **Voltage.** The design operates at 3.3V.
- **Density.** The estimated size of the design is 83,000 gates, with the usage broken out in [Table 8](#).
- **Performance.** The highest clock speed used in the device is 64 MHz, used to clock the SDRAM controller state machines. The remaining logic runs at sub multiples of this clock rate.
- **Packaging.** The size constraints imposed on most modern designs dictates a high-density surface mount package.

Based on these criteria the device selected for this design is the XC2S100. This device offers 100K gates density, 3.3V operation, 176 user I/O, and is packaged in a space saving FG256 BGA package.

Table 8: FPGA Resource Usage Summary

Interface	CLB Usage	Number of Signals
CPU	25	51
LCD Display	58	9
IRDA	59	3
USB	21	3
DAC	23	5
ADC	0	3
SDRAM	100	9
FLASH	100	10
CompactFlash	100	17
Memory Address Bus	4	11
Memory Data Bus	10	16
Total:	500	137

Conclusion

The design that has been outlined meets both original design objectives. Even with budgetary pricing the cost of the solution is well below \$100. [Table 9](#) shows the cost breakdown of the system. The design also has enough spare resources both in terms of CPU cycles and FPGA gates to support field upgrades. Operating at a core clock speed of 64 MHz, the RC32364 will provide enough performance for both audio decoding and user interface functions. By locking the audio decode functions in the instruction cache a significant increase in system performance as well as reduced power consumption is achieved.

This design also illustrates how manufacturers can create designs that the optimized integration of an ASIC while supporting the manufacturing and field upgrade flexibility of an FPGA.

Table 9: NG Player Semiconductor BOM

Item	Qty.	Mfg.	Part Number	Description	Volume	Unit Cost	Ext. Cost.
1	4	Samsung	KM29U6400T	Flash, 64Mb	1M/Yr.	\$10.00	\$40.00
2	1	Micron	Mt48C1LC1M16A1TG7SIT	SDRAM, 512K x 16 x 2 banks	200K/m	\$3.50	\$3.50
3	1	IDT	RC32364-133	RISC CPU	100K	\$11.50	\$11.50
4	1	Xilinx	XC2S100	FPGA	20K/m	\$10.00	\$10.00
5	1	Xilinx	XC1801	Serial Configuration PROM	20K/m	\$3.00	\$3.00
6	1	NSC	USB9602	USB Interface Controller	20K/m	\$1.63	\$1.63
7	1	SMOS	SED1758T0A	LCD Common Driver, 160 Rows	20K/m	\$2.50	\$2.50
8	1	SMOS	SED1743T0A	LCD Segment Driver, 160 Columns	20K/m	\$2.50	\$2.50
9	1	Various	TBD	160 x 160 LCD Panel, Glass Only	est.	\$5.00	\$5.00
10	1	MicroTouch	TBD	Touch Screen	est.	\$5.00	\$5.00
11	1	Infineon	IRDT6100	1Mb IRDA Transceiver	20K/m	\$2.00	\$2.00
12	1	Crystal	CS4343	DAC Stereo Audio	est	\$2.00	\$2.00
13	1	Maxim	MAX1108	AD Converter	disti	\$2.68	\$2.68
14	1	Maxim	MAX1705	Step-up DC to DC Converter	10K	\$2.81	\$2.81
						Total:	\$94.12

Notes: BOM includes only semiconductor content.

References

RC32364 RISController, Hardware User's Manual, April 1999, Integrated Device Technology

Xilinx Spartan-II FPGA Data Sheet, January 2000, Xilinx

IRMS6100 1.15 Mb/s IrDT Data Transceiver Data Sheet, May 1999, Infineon Technologies

SED1743 160-bit LCD Common Driver Data Sheet, Epson Electronics

SED1758 160-bit LCD Segment Driver Data Sheet, Epson Electronics

CS4343 Low Voltage, Stereo DAC with Headphone Amp Data Sheet, June 1999, Cirrus Logic

MAX1108 2-Channel, Serial 8-bit ADC, Data Sheet, October 1998, Maxim Integrated Products

USB9602 Full Speed Function Controller With DMA Support Data Sheet, May 1998, National Semiconductor

MT48LC1M16A1 S - 512K x 16 x 2 banks Synchronous DRAM Data Sheet, August 1999, Micron Technologies

KM29U64000T 8M x 8 bit NAND Flash Memory, April 1999, Samsung Semiconductor

Revision History

Date	Version #	Revision
11/24/99	1.0	Initial release.

© 1999 Xilinx, Inc. All rights reserved. All Xilinx trademarks, registered trademarks, patents, and disclaimers are as listed at <http://www.xilinx.com/legal.htm>. All other trademarks and registered trademarks are the property of their respective owners.

Free Manuals Download Website

<http://myh66.com>

<http://usermanuals.us>

<http://www.somanuals.com>

<http://www.4manuals.cc>

<http://www.manual-lib.com>

<http://www.404manual.com>

<http://www.luxmanual.com>

<http://aubethermostatmanual.com>

Golf course search by state

<http://golfingnear.com>

Email search by domain

<http://emailbydomain.com>

Auto manuals search

<http://auto.somanuals.com>

TV manuals search

<http://tv.somanuals.com>