

DIGITAL INSTALLATION MIXER

IMX644

Owner's Manual

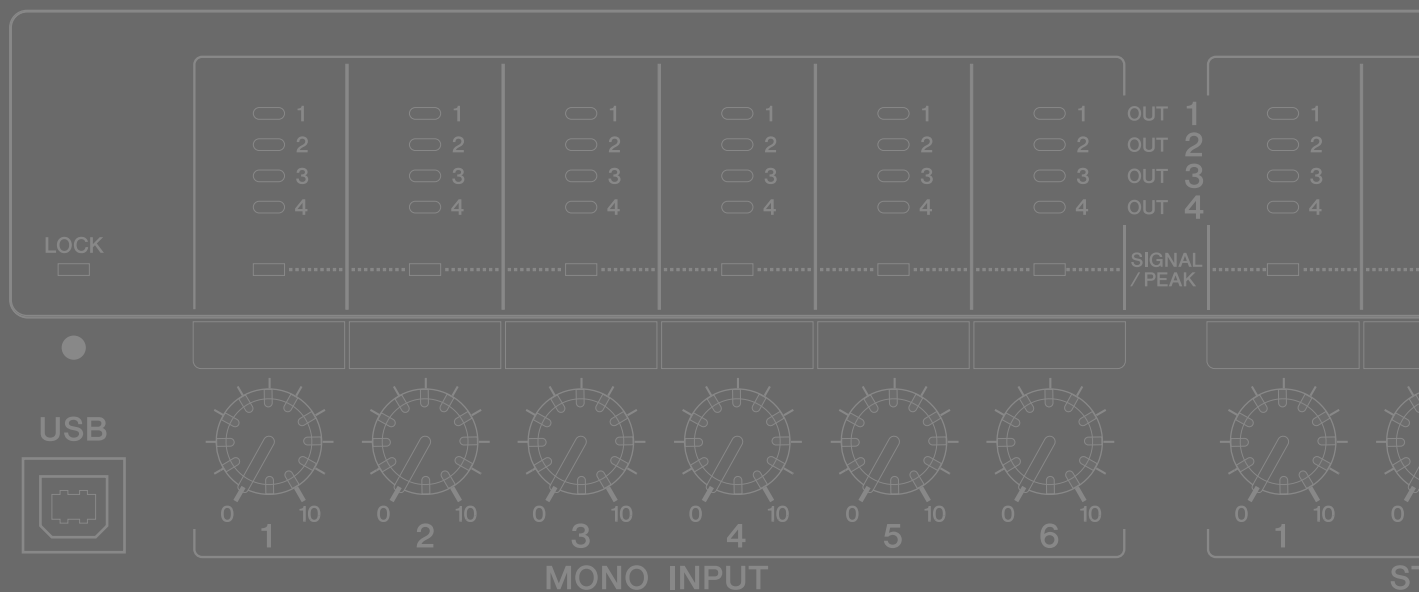

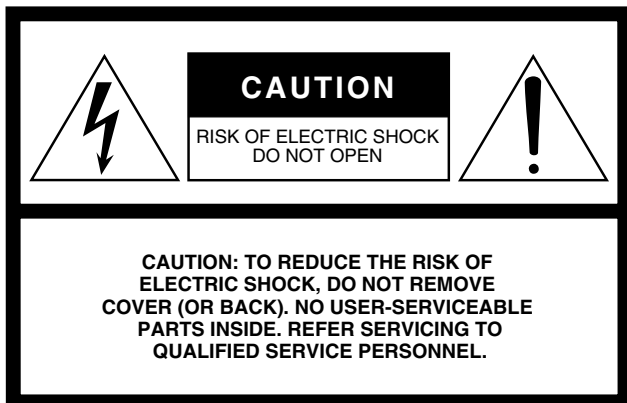

Explanation of Graphical Symbols

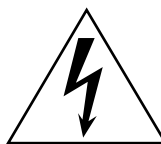

The lightning flash with arrowhead symbol within an equilateral triangle is intended to alert the user to the presence of uninsulated “dangerous voltage” within the product’s enclosure that may be of sufficient magnitude to constitute a risk of electric shock to persons.



The exclamation point within an equilateral triangle is intended to alert the user to the presence of important operating and maintenance (servicing) instructions in the literature accompanying the product.

The above warning is located on the top of the unit.

IMPORTANT SAFETY INSTRUCTIONS

- 1 Read these instructions.
- 2 Keep these instructions.
- 3 Heed all warnings.
- 4 Follow all instructions.
- 5 Do not use this apparatus near water.
- 6 Clean only with dry cloth.
- 7 Do not block any ventilation openings. Install in accordance with the manufacturer’s instructions.
- 8 Do not install near any heat sources such as radiators, heat registers, stoves, or other apparatus (including amplifiers) that produce heat.
- 9 Do not defeat the safety purpose of the polarized or grounding-type plug. A polarized plug has two blades with one wider than the other. A grounding type plug has two blades and a third grounding prong. The wide blade or the third prong are provided for your safety. If the provided plug does not fit into your outlet, consult an electrician for replacement of the obsolete outlet.
- 10 Protect the power cord from being walked on or pinched particularly at plugs, convenience receptacles, and the point where they exit from the apparatus.
- 11 Only use attachments/accessories specified by the manufacturer.
- 12 Use only with the cart, stand, tripod, bracket, or table specified by the manufacturer, or sold with the apparatus. When a cart is used, use caution when moving the cart/apparatus combination to avoid injury from tip-over.
- 13 Unplug this apparatus during lightning storms or when unused for long periods of time.
- 14 Refer all servicing to qualified service personnel. Servicing is required when the apparatus has been damaged in any way, such as power-supply cord or plug is damaged, liquid has been spilled or objects have fallen into the apparatus, the apparatus has been exposed to rain or moisture, does not operate normally, or has been dropped.



WARNING

TO REDUCE THE RISK OF FIRE OR ELECTRIC SHOCK, DO NOT EXPOSE THIS APPARATUS TO RAIN OR MOISTURE.

(UL60065_03)

FCC INFORMATION (U.S.A.)

1. IMPORTANT NOTICE: DO NOT MODIFY THIS UNIT!

This product, when installed as indicated in the instructions contained in this manual, meets FCC requirements. Modifications not expressly approved by Yamaha may void your authority, granted by the FCC, to use the product.

2. IMPORTANT: When connecting this product to accessories and/or another product use only high quality shielded cables. Cable/s supplied with this product MUST be used. Follow all installation instructions. Failure to follow instructions could void your FCC authorization to use this product in the USA.

3. NOTE: This product has been tested and found to comply with the requirements listed in FCC Regulations, Part 15 for Class “B” digital devices. Compliance with these requirements provides a reasonable level of assurance that your use of this product in a residential environment will not result in harmful interference with other electronic devices. This equipment generates/uses radio frequencies and, if not installed and used according to the instructions found in the users manual, may cause interference harmful to the operation of other electronic devices. Compliance with FCC regulations does

not guarantee that interference will not occur in all installations. If this product is found to be the source of interference, which can be determined by turning the unit “OFF” and “ON”, please try to eliminate the problem by using one of the following measures:

Relocate either this product or the device that is being affected by the interference.

Utilize power outlets that are on different branch (circuit breaker or fuse) circuits or install AC line filter/s.

In the case of radio or TV interference, relocate/reorient the antenna. If the antenna lead-in is 300 ohm ribbon lead, change the lead-in to co-axial type cable.

If these corrective measures do not produce satisfactory results, please contact the local retailer authorized to distribute this type of product. If you can not locate the appropriate retailer, please contact Yamaha Corporation of America, Electronic Service Division, 6600 Orangethorpe Ave, Buena Park, CA90620

The above statements apply ONLY to those products distributed by Yamaha Corporation of America or its subsidiaries.

PRECAUTIONS

PLEASE READ CAREFULLY BEFORE PROCEEDING

* Please keep this manual in a safe place for future reference.



WARNING

Always follow the basic precautions listed below to avoid the possibility of serious injury or even death from electrical shock, short-circuiting, damages, fire or other hazards. These precautions include, but are not limited to, the following:

Power supply/Power cord

- Only use the voltage specified as correct for the device. The required voltage is printed on the name plate of the device.
- Use only the included power cord.
If you intend to use the device in an area other than in the one you purchased, the included power cord may not be compatible. Please check with your Yamaha dealer.
- Do not place the power cord near heat sources such as heaters or radiators, and do not excessively bend or otherwise damage the cord, place heavy objects on it, or place it in a position where anyone could walk on, trip over, or roll anything over it.
- Be sure to connect to an appropriate outlet with a protective grounding connection. Improper grounding can result in electrical shock.

Do not open

- Do not open the device or attempt to disassemble the internal parts or modify them in any way. The device contains no user-serviceable parts. If it should appear to be malfunctioning, discontinue use immediately and have it inspected by qualified Yamaha service personnel.

Water warning

- Do not expose the device to dripping or splashing, use it near water or in damp or wet conditions, or place containers on it containing liquids which might spill into any openings. If any liquid such as water seeps into the device, turn off the power immediately and unplug the power cord from the AC outlet. Then have the device inspected by qualified Yamaha service personnel.
- Never insert or remove an electric plug with wet hands.

If you notice any abnormality

- If the power cord or plug becomes frayed or damaged, or if there is a sudden loss of sound during use of the device, or if any unusual smells or smoke should appear to be caused by it, immediately turn off the power switch, disconnect the electric plug from the outlet, and have the device inspected by qualified Yamaha service personnel.
- If this device should be dropped or damaged, immediately turn off the power switch, disconnect the electric plug from the outlet, and have the device inspected by qualified Yamaha service personnel.



CAUTION

Always follow the basic precautions listed below to avoid the possibility of physical injury to you or others, or damage to the device or other property. These precautions include, but are not limited to, the following:

Power supply/Power cord

- Remove the electric plug from the outlet when the device is not to be used for extended periods of time, or during electrical storms.
- When removing the electric plug from the device or an outlet, always hold the plug itself and not the cord. Pulling by the cord can damage it.

Location

- Before moving the device, remove all connected cables.
- When setting up the devices, make sure that the power switch can be easily turned ON/OFF. If some trouble or malfunction occurs, immediately turn off the power switch and disconnect the plug from the outlet.
- If the device is mounted in an EIA standard rack, carefully read the section "Precautions for Rack Mounting" on page 7. Inadequate ventilation can result in overheating, possibly causing damage to the device(s), malfunction, or even fire.
- Avoid setting all equalizer controls and faders to their maximum. Depending on the condition of the connected devices, doing so may cause feedback and may damage the speakers.

- Do not expose the device to excessive dust or vibrations, or extreme cold or heat (such as in direct sunlight, near a heater, or in a car during the day) to prevent the possibility of panel disfiguration or damage to the internal components.
- Do not place the device in an unstable position where it might accidentally fall over.
- Do not block the vents. This device has ventilation holes at the sides to prevent the internal temperature from becoming too high. In particular, do not place the device on its side or upside down. Inadequate ventilation can result in overheating, possibly causing damage to the device(s), or even fire.
- Do not use the device in the vicinity of a TV, radio, stereo equipment, mobile phone, or other electric devices. Doing so may result in noise, both in the device itself and in the TV or radio next to it.

Connections

- Before connecting the device to other devices, turn off the power for all devices. Before turning the power on or off for all devices, set all volume levels to minimum.
- The included power cable has a three-conductor plug, so if the AC outlet is grounded the IMX644 will be grounded appropriately.

Handling caution

- When turning on the AC power in your audio system, always turn on the power amplifier LAST, to avoid speaker damage. When turning the power off, the power amplifier should be turned off FIRST for the same reason.
- Condensation can occur in the device due to rapid, drastic changes in ambient temperature – when the device is moved from one location to another, or air conditioning is turned on or off, for example. Using the device while condensation is present can cause damage. If there is reason to believe that condensation might have occurred, leave the device for several hours without turning on the power until the condensation has completely dried out.
- Do not insert your fingers or hands in any gaps or openings on the device (ports, etc.).
- Avoid inserting or dropping foreign objects (paper, plastic, metal, etc.) into any gaps or openings on the device (ports, etc.) If this happens, turn off the power immediately and unplug the power cord from the AC outlet. Then have the device inspected by qualified Yamaha service personnel.
- Do not apply oil, grease, or contact cleaner to the faders. Doing so may cause problems with electrical contact or fader motion.
- Do not rest your weight on the device or place heavy objects on it, and avoid use excessive force on the buttons, switches or connectors.

Yamaha cannot be held responsible for damage caused by improper use or modifications to the device, or data that is lost or destroyed.

Always turn the power off when the device is not in use.

The performance of components with moving contacts, such as switches, volume controls, and connectors, deteriorates over time. Consult qualified Yamaha service personnel about replacing defective components.

European models
Purchaser/User Information specified in EN55103-1 and EN55103-2.
Inrush Current: 10 A
Conforms to Environments: E1, E2 E3 and E4

SPECIAL NOTICES

- The illustrations as shown in this manual are for instructional purposes only, and may appear somewhat different from those on your device.
- The company names and product names in this manual are the trademarks or registered trademarks of their respective companies.
- Specifications and descriptions in this owner's manual are for information purposes only. Yamaha Corp. reserves the right to change or modify products or specifications at any time without prior notice. Since specifications, equipment or options may not be the same in every locale, please check with your Yamaha dealer.

COMPLIANCE INFORMATION STATEMENT (DECLARATION OF CONFORMITY PROCEDURE)

Responsible Party : Yamaha Corporation of America
Address : 6600 Orangethorpe Ave., Buena Park, Calif. 90620
Telephone : 714-522-9011
Type of Equipment : DIGITAL INSTALLATION MIXER
Model Name : IMX644

This device complies with Part 15 of the FCC Rules.
Operation is subject to the following two conditions:
1) this device may not cause harmful interference, and
2) this device must accept any interference received including interference that may cause undesired operation.
See user manual instructions if interference to radio reception is suspected.

* This applies only to products distributed by
YAMAHA CORPORATION OF AMERICA.

(FCC DoC)

IMPORTANT NOTICE FOR THE UNITED KINGDOM Connecting the Plug and Cord

WARNING: THIS APPARATUS MUST BE EARTHED
IMPORTANT. The wires in this mains lead are coloured in accordance with the following code:

GREEN-AND-YELLOW	: EARTH
BLUE	: NEUTRAL
BROWN	: LIVE

As the colours of the wires in the mains lead of this apparatus may not correspond with the coloured markings identifying the terminals in your plug proceed as follows:

The wire which is coloured GREEN-and-YELLOW must be connected to the terminal in the plug which is marked by the letter E or by the safety earth symbol \oplus or colored GREEN or GREEN-and-YELLOW.

The wire which is coloured BLUE must be connected to the terminal which is marked with the letter N or coloured BLACK.

The wire which is coloured BROWN must be connected to the terminal which is marked with the letter L or coloured RED.

• This applies only to products distributed by Yamaha Music U.K. Ltd.

(3 wires)

Table of contents

Introduction	Features 6
	Precautions for Rack Mounting 7
	Before Operation 7
	Acquiring the IMX644 Manager Software and Manuals 7
Controls and Functions	Front Panel 8
	Rear Panel..... 10
Connections	System Example..... 12
	Connectors and Cables 13
Mix Functions	Input Channels 15
	Output Channels..... 17
	Others 17
Appendix	Troubleshooting 18
	Memory Initialization 18
	IMX644 Status List 19
	Remote Control Protocol Specifications 20
	General Specifications..... 21
	Input/output Characteristics 21
	Electrical Characteristics 22
	GPI Circuit Example 23
	Dimensions..... 24
	Block Diagram 25

Introduction

Thank you for purchasing the Yamaha IMX644 Digital Installation Mixer. In order to take full advantage of the IMX644 functionality and to ensure trouble-free operation, please read this owner's manual carefully before use. After you have read the manual, keep it in a safe place for reference when needed.

Features

■ Versatile Input/Output Configuration

The IMX644 features an input/output configuration that is ideal for a wide range of applications: six mono inputs, four stereo inputs, two stereo outputs, two mono outputs, and one dedicated stereo output for recording.

■ 16 Memories

Up to 16 sets of mixer settings can be stored in memory and instantly recalled as required. Four of the memories can be directly recalled via front-panel MEMORY [A] through [D] buttons.

■ Optical Digital I/O

Connecting to compatible devices (CD and DVD players, for example) via the optical digital interface allows accurate signal transfer with no loss of signal quality. The digital input features a built-in sample rate converter, so there is no need for word clock synchronization.

■ Powerful Mixing Features

• Parametric EQ

Parametric equalization is provided on all input channels: 3-band EQ on mono input channels, and 2-band EQ on stereo input channels.

6-band EQ is provided on all outputs except the recording output.

• Feedback Suppressor

Feedback suppression is provided on all six mono input channels.

The Feedback Suppressor provides two stages of feedback prevention: static filters that can be set in advance, and dynamic filters that self-adjust in real time to control feedback.

• Priority for Specified Voice or Music Sources

The Priority Ducker automatically “ducks” (reduces the volume of) the background when a signal is applied to a specified mono input channel, making announcements stand out for greater intelligibility. All stereo inputs assigned to the same output channel are reduced to a specified level when priority input is detected.

Music Override gives priority to a music source applied to a specified stereo input channel. All other stereo inputs assigned to the same output channel are muted when priority input is detected.

• Delay

Precise delays can be applied to all outputs to allow time alignment for a solid sonic image with clear imaging and optimum overall sound quality throughout the listening area.

Accessories

- AC power cord
- Rubber feet x 4
- Euroblock plug (3P) x 12
- Owner's Manual (this document)

Precautions for Rack Mounting

This unit will operate stably in an environmental temperature of 0–40°C. If you install this device together with multiple units of the same device or other devices in an EIA standard rack, the heat produced by the various devices may raise the ambient temperature inside the rack, resulting in inefficient performance. To ensure that the heat produced by this device can be dissipated appropriately, please ensure the following conditions when rack-mounting it.

- If multiple units are mounted in the same rack, leave a 1U rack space between every two units. Also either leave the open spaces uncovered or install appropriate ventilating panels to minimize the possibility of heat buildup.
- When mounting this device together with other heat-producing equipment such as power amplifiers, leave 1U or more space between it and other devices. Install a ventilation panel in this vacant space or leave it open to ensure adequate cooling.
- To ensure sufficient airflow, leave the rear of the rack open and position it at least 10 centimeters from walls or other surfaces. If the rear of the rack can't be left open, install a commercially available fan or similar ventilating option to secure sufficient airflow. If you've installed a fan kit, there may be cases in which closing the rear of the rack will produce a greater cooling effect. Refer to the rack and/or fan unit manual for details.

Before Operation

■ Connecting the AC Power Cable

CAUTION

- Before connecting the power cable, make sure that the power switches of all devices are turned OFF.

First connect the supplied power cable to the [AC IN] socket on the rear panel of the IMX644, then connect the AC plug to an appropriate AC power outlet (make sure the local supply voltage matches the rated AC voltage of the unit).

■ Powering ON or OFF

CAUTION

- To prevent loud noise bursts from the speakers when powering up the system, turn devices ON in the following order: audio sources (microphones, CD players, etc.), IMX644, and finally power amplifiers. Reverse this order when turning the system off.

- 1 Press the [ON] end of the [POWER] switch to turn the unit ON.**
- 2 Press the [OFF] end of the [POWER] switch to turn the unit OFF.**

CAUTION

- Rapidly turning the unit ON and OFF in succession can cause it to malfunction. After turning the unit OFF, wait for more than 6 seconds before turning it ON again.

Acquiring the IMX644 Manager Software and Manuals

The information in this manual deals primarily with setting up and operating the IMX644 hardware.

For detailed parameter control the IMX644 Manager software application is required. The IMX644 Manager software and manuals can be downloaded from Yamaha's professional audio website (URL below).

<http://www.yamahaproaudio.com/>

The available IMX644 Manager documents are as follows:

- **IMX644 Manager Owner's Manual**
This manual contains detailed information relating to the IMX644 unit and IMX644 Manager software.

Controls and Functions

Front Panel

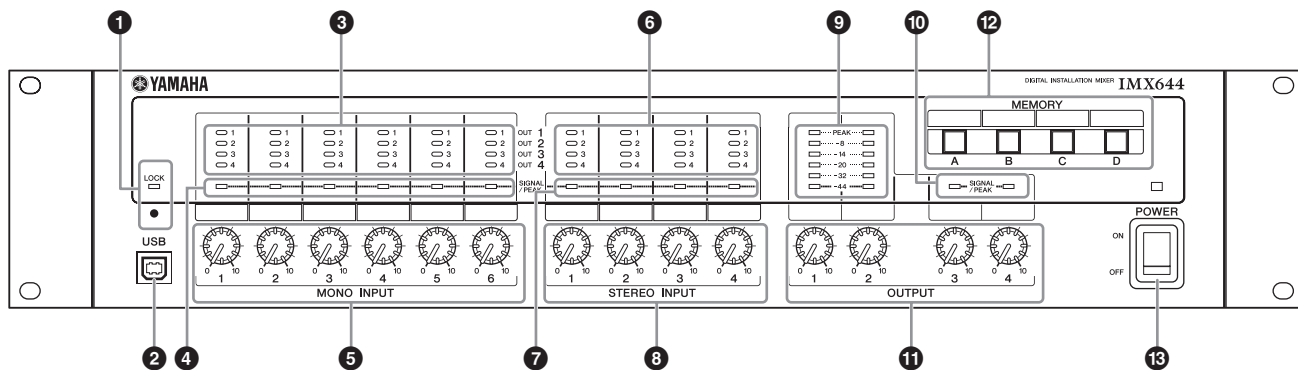

1 [LOCK] Switch and Indicator

The [LOCK] switch can be used to “lock” the panel level knobs (5, 8, and 11), making them inoperable and preventing accidental changes. After setting levels and/or recalling a memory as required, press the [LOCK] switch with a thin object (such as the tip of a pen) to prevent further changes to the level settings. The LOCK indicator lights red when the controls are locked.

Press the [LOCK] switch a second time to unlock the controls and allow normal operation of the level knobs.

NOTE

- The LOCK buttons in the IMX644 Manager application INPUT display can be used to enable independent operation of each panel level control.
- If the settings of the level knobs have been increased since the [LOCK] switch was engaged, the settings at the time the [LOCK] switch was engaged will be retained when it is disengaged. In order to increase a level setting after disengaging the [LOCK] switch in such a case it is necessary to lower the setting of the knob to the point at which it was locked, and then raise the level as required.
- When the power is turned ON, the MEMORY number that was active when the power was turned OFF is recalled. Save the memory using the IMX644 Manager application before engaging the [LOCK] switch.
- The LOCK function is temporarily disengaged when the IMX644 Manager application goes online. The LOCK function will be re-engaged if the unit is restarted, so don't operate the [LOCK] switch while the IMX644 Manager is online.

2 [USB] Connector

The computer running the IMX644 Manager application can be connected to the IMX644 via this connector. The [USB] connector cannot be used at the same time as the rear-panel [REMOTE] connector.

Precautions when using the [USB] connector

When connecting the computer to the [USB] connector, make sure to observe the following points. Failing to do so risks freezing the computer and corrupting or losing the data. If the computer or the device freezes, restart the application software or the computer OS, or turn the power to the device off then on again.

CAUTION

- Use an AB type USB cable of less than about 3 meters.
- Before connecting the computer to the [USB] connector, exit from any power-saving mode of the computer (such as suspend, sleep, standby).
- Before turning on the power to the device, connect the computer to the [USB] connector.
- Execute the following before turning the power to the device on/off or plugging/unplugging the USB cable to/from the [USB] connector.
 - Quit any open application software on the computer.
 - Make sure that data is not being transmitted from the device.
- While the computer is connected to the device, you should wait for six seconds or more between these operations: (1) when turning the power of the device off then on again, or (2) when alternately connecting/disconnecting the USB cable.

■ MONO INPUT Section

③ Matrix Indicators

The outputs to which each mono input are assigned are displayed by orange indicators.

④ [SIGNAL/PEAK] Indicators

These indicators light green when a signal is detected at the corresponding mono input.

The [SIGNAL/PEAK] indicators also light red to indicate excessive input level at the corresponding input. If excessive input level is indicated either reduce the output level of the connected source, or reduce the IMX644 input sensitivity via the appropriate rear-panel [PAD] switch or by reducing the [INPUT GAIN] setting via the IMX644 Manager application.

⑤ Level Knobs

These knobs adjust the input level of the corresponding mono channels.

■ STEREO INPUT Section

⑥ Matrix Indicators

The outputs to which each stereo input are assigned are displayed by orange indicators.

⑦ [SIGNAL/PEAK] Indicators

These indicators light green when a signal is detected at the corresponding stereo input.

The [SIGNAL/PEAK] indicators also light red to indicate excessive input level at the corresponding input. If excessive input level is indicated, reduce the output level of the connected source.

NOTE

- The [SIGNAL/PEAK] indicator may light red when certain types of signals are received via the OPTICAL input, but in such cases the signal is within range and no further adjustments are required.

⑧ Level Knobs

These knobs adjust the input level of the corresponding stereo channels.

■ OUTPUT Section

⑨ Level Meter

Displays the levels of the signal being output via OUTPUT 1 and 2.

If the PEAK indicator lights the output level is too high. If excessively high output levels are indicated, reduce the input and/or output levels as required.

NOTE

- The signals OUTPUT 1 and 2 are both stereo pairs, so each level meter indicates the output level of the mixed L and R signal.

⑩ [SIGNAL/PEAK] Indicators

These indicators light green when a signal is detected at OUTPUT 3 and 4.

The [SIGNAL/PEAK] indicators also light red to indicate excessive output level at the corresponding output. If excessive output level is indicated, reduce the input level or output level.

⑪ Level Knobs

These knobs adjust the output level from the corresponding output channels.

⑫ MEMORY [A] – [D] Buttons

• Recalling Memories

To recall a memory press and hold one of the MEMORY buttons for about 2 seconds – the button’s indicator will light and the mix settings assigned to that memory will be recalled.

Settings are stored in the IMX644 memories via the IMX644 Manager application. Memories A through D all contain the same settings when the unit is initially shipped from the factory.

• Switching Modes

To start the unit in IMX644 Manager mode, hold the MEMORY [D] button while turning the [POWER] switch ON. The unit starts up in the “normal” mode if the power is turned on while the MEMORY [D] button is not held.

IMX644 Manager Mode	This mode allows communication with the IMX644 application. Communication with AMX and similar external controllers cannot occur in this mode.
Normal Mode	This is the unit’s normal operating mode. Communication with AMX and similar external controllers is also possible in this mode. Communication with the IMX644 Manager application is not possible in this mode.

⑬ [POWER] Switch & Indicator

Turns power to the unit ON or OFF. The indicator lights green when the power is ON.

NOTE

- Since the level settings for each channel are stored in the IMX644 unit itself, be sure that the IMX644 Manager application is online when setting up the memories.

Rear Panel

NOTE

- Refer to “Connectors and Cables” on page 13 for details on connectors and cables for use with the IMX644.

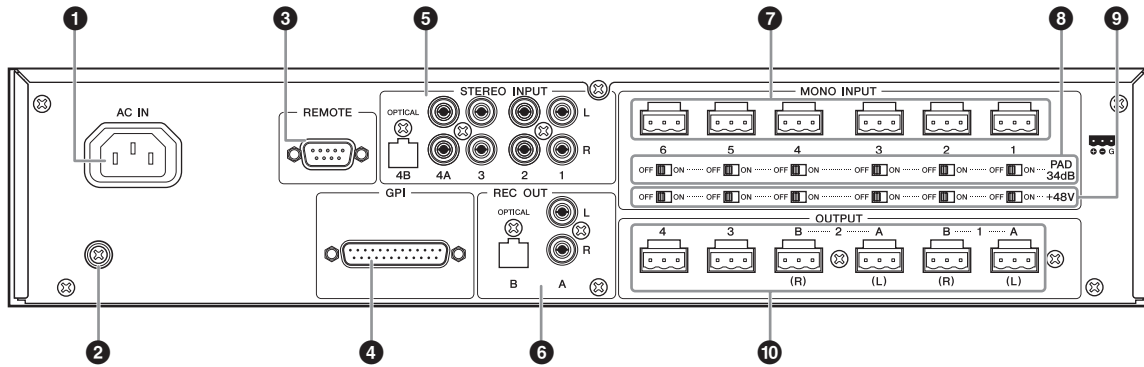

1 [AC IN] Connector

Connect the supplied AC cable here. First connect the AC cable to the IMX644, then plug it into an appropriate AC outlet.

2 Earth Screw

For maximum safety, please earth the unit properly. The supplied AC power cable is a 3-wire type, so if the AC outlet used is properly earthed the IMX644 will be earthed as well. Hum and interference may be further reduced in some cases by also connecting the earth screw to an earth point.

3 [REMOTE] Connector

This RS-232C connector allows communication with a computer running the IMX644 Manager application or external controllers.

The [REMOTE] connector cannot be used simultaneously with the front-panel [USB] connector. If both connectors are connected, the front-panel [USB] connector takes priority.

4 [GPI] Connector

This 25-pin D-sub GPI (General Purpose Interface) connector provides eight input ports and eight output ports for a variety of control signals, plus one dedicated output port that indicates the unit’s power ON/OFF status.

STEREO INPUT Section

5 L/R Connectors 1, 2, 3, 4A, and OPTICAL 4B

The output from CD players and other stereo line-level sources can be connected to these stereo inputs.

NOTE

- The 4A (L/R) connectors and 4B (OPTICAL) connector cannot be used simultaneously.

REC OUT Section

6 L/R Connectors A and OPTICAL B

A CD recorder or other stereo recorder can be connected here.

NOTE

- A feedback loop can occur if a CD recorder or similar device is connected to both a STEREO INPUT and the REC OUT connectors. In such cases use the IMX644 Manager application MATRIX controls to turn the OUTPUT channel to REC OUT connector assignment off.

MONO INPUT Section

7 Euroblock Connectors

Microphones and similar mono sources can be connected to these balanced input connectors. High-quality head amplifiers are built in. Refer to page 13 for instructions on connecting to the Euroblock connectors.

8 [PAD] Switches

When ON, input to the corresponding mono channel is attenuated by 34 dB. The pads are ideal for matching input sensitivity to the output from wireless microphone tuners and similar high-output source devices.

9 [+48V] Switch

When ON, 48V phantom power is applied to the corresponding mono input. Turn the [+48V] switch ON for channels to which phantom-powered condenser microphones or other devices that require phantom power are connected.

CAUTION

- Make sure that phantom power is turned OFF unless it is needed.
- When turning phantom power ON, make sure that no equipment other than phantom-powered devices such as condenser microphones are connected to the corresponding MONO INPUT connectors. Applying phantom power to a device that does not require phantom power can damage the device.
- Do not connect or disconnect a device to a MONO INPUT while phantom power is applied. Doing so can damage the connected device and/or the unit itself.
- Make sure that the system's power amplifiers and/or powered speakers are turned OFF while turning phantom power ON or OFF to prevent damage to the speakers. We also recommend setting all level controls to minimum level. If these measures are not observed sudden high-level noise bursts can potentially damage equipment and even the hearing of people in the area.

■ OUTPUT Section

10 Euroblock Connectors

These balanced output connectors are for connection to power amplifiers and other output devices.

OUTPUT 1 and 2 are stereo outputs. The A connector outputs the left-channel signal, and the B connector outputs the right-channel signal. OUTPUT 1 and 2 can also be assigned for mono output via the IMX644 Manager application.

OUTPUT 3 and 4 are mono outputs. Refer to page 13 for instructions on connecting to the Euroblock connectors.

Connections

System Example

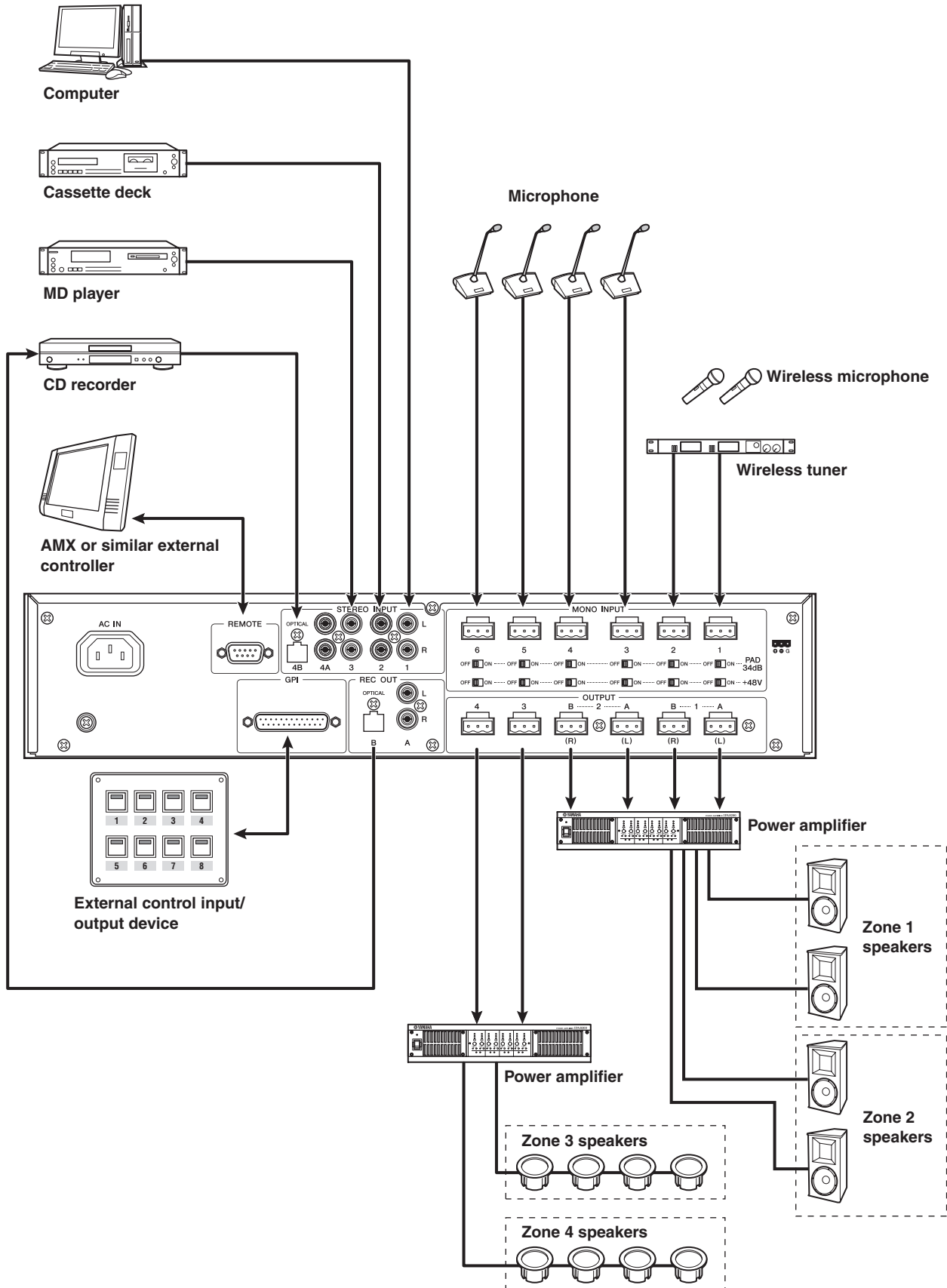

Connectors and Cables

■ [MONO INPUT] and [OUTPUT] Connectors (3-pin Euroblock)

Connect external microphones, amplifiers and other devices to the rear-panel [MONO INPUT] and [OUTPUT] connectors via cables fitted with the supplied 3-pin Euroblock plugs.

Follow the procedure outlined in this section to attach the Euroblock plugs to the appropriate cables.

Euroblock Pin Assignments

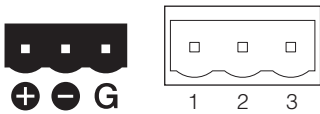

Pin No.	Signal name
1	HOT
2	COLD
3	GND

Use balanced lines to connect microphones and similar sources to the [MONO INPUT] connectors. Wire balanced cables as shown in the diagram below.

XLR-3-11C (or equivalent)

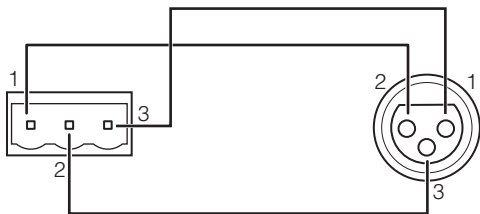

When an amplifier to be connected to the OUTPUT connector has balanced XLR type inputs, wire the connection cable as shown in the diagram below.

XLR-3-12C (or equivalent)

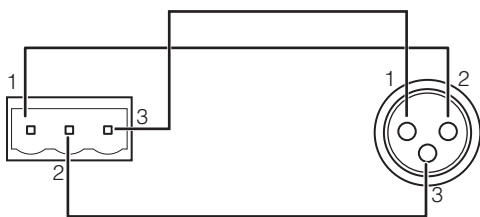

Euroblock Plug Connection

Use the included Euroblock plug (3P) to make connections to the [MONO INPUT] and [OUTPUT] connectors.

● Cable preparation

- To prepare the cable for attachment to a Euroblock connector, strip the wire as shown in the illustration, and use stranded wire to make connections. With a Euroblock connection, the stranded wire may be prone to breakage because of metal fatigue due to the weight of the cable or due to vibration. When rack-mounting your equipment, use a lacing bar when possible to bundle and fasten the cables.

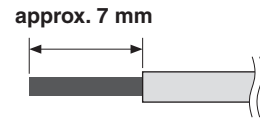

- If cables will be frequently connected and disconnected, as in the case of a portable installation, we recommend that you use ferrules with insulation sleeves. Use a ferrule whose conductor portion has an external diameter of 1.6 mm or less, and a length of approximately 7 mm (such as the AI0,5-6WH made by the Phoenix Contact corporation).

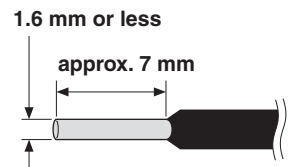

⚠ CAUTION

- If you use stranded wire, do not tin (plate with solder) the exposed end.

1 Loosen the terminal screws.

NOTE

- A "minus" type screwdriver with a blade width of approximately 3 millimeters is recommended for Euroblock connector attachment.

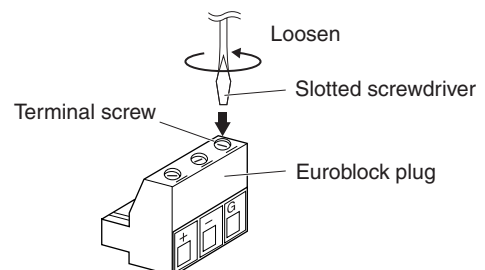
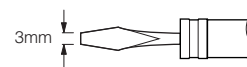

2 Insert the cables.

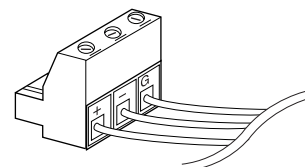

3 Securely tighten the terminal screws.

Pull the cables (not too strongly) to confirm that they are securely connected.

4 Connect the Euroblock plug to the IMX644 Euroblock connector.

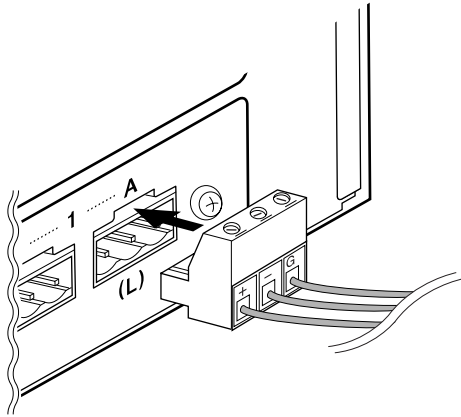

[REMOTE] Connector (RS-232C)

Connect to this connector when controlling the IMX644 from the IMX644 Manager application or an external AMX/Crestion controller. Use an RS-232C cross cable for connection.

Connector Pin Assignments

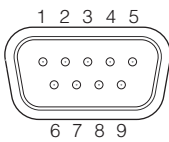

Pin No.	Signal name
1	Unused
2	RxD
3	TxD
4	DTR
5	GND
6	DSR
7	RTS
8	CTS
9	Unused

An external AMX or similar controller can be used to send commands to the IMX644 to recall memories and adjust the level of individual channels. Refer to page 20 for information on the available remote control commands.

[GPI] Connector (25-pin D-sub)

External GPI (General Purpose Interface) control devices can be connected to this connector to allow input and output of remote control signals.

The IMX644 GPI port has eight inputs and eight outputs, plus a dedicated "POWER MONITOR" output that indicates the unit's ON/OFF status.

The input pins are normally left open. Shorting an input pin to ground (GND) recalls the corresponding memory number.

The output pins are open-collector outputs that deliver a maximum output of +35 volts, with a maximum current capability of 30 mA per port.

For the POWER MONITOR outputs, pins 24 and 25 are "closed" (shorted) when the power is ON. The POWER MONITOR COLD pin (pin 25) is internally connected to the GND pins.

The IMX644 Manager application can be used for parameter assignment.

Connector Pin Assignments

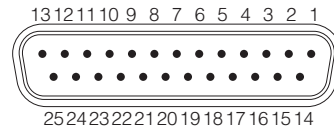

Pin No.	Signal name
1	GND
2	GND
3	INPUT 1
4	INPUT 2
5	INPUT 3
6	INPUT 4
7	INPUT 5
8	INPUT 6
9	INPUT 7
10	INPUT 8
11	GND
12	GND
13	GND
14	OUTPUT 1
15	OUTPUT 2
16	OUTPUT 3
17	OUTPUT 4
18	OUTPUT 5
19	OUTPUT 6
20	OUTPUT 7
21	OUTPUT 8
22	GND
23	GND
24	POWER MONITOR HOT
25	POWER MONITOR COLD

Mix Functions

The IMX644 mix functions can be programmed and edited in detail using the IMX644 Manager installed on a computer (page 7). The mix functions that can be controlled by the IMX644 Manager application are discussed in this section. For operating details refer to the IMX644 Manager Owner's Manual.

To enable communication with the IMX644 Manager application, press and hold the IMX644 MEMORY [D] button while turning the [POWER] switch ON.

Input Channels

■ GAIN

The gain of the mono input channel head amplifiers can be individually adjusted and displayed.

Parameter	Range	Initial value
GAIN (PAD is off)	-54dB – -30dB	-35dB
GAIN (PAD is ON)	-20dB – +4dB	-1dB

■ INPUT EQ

The parameters of the input channel equalizers can be individually adjusted and displayed. The parameters available for each channel are listed below.

MONO INPUT CHANNEL

Parameter		Range	Initial value
HIGH	G	-15dB – +15dB	0dB
	F	2kHz – 18kHz	10kHz
MID	G	-15dB – +15dB	0dB
	F	40Hz – 18kHz	2kHz
	Q	0.5 – 12.0	0.7
LOW	G	-15dB – +15dB	0dB
	F	40Hz – 2kHz	100Hz

STEREO INPUT CHANNEL

Parameter		Range	Initial value
HIGH	G	-15dB – +15dB	0dB
	F	2kHz – 18kHz	10kHz
LOW	G	-15dB – +15dB	0dB
	F	40Hz – 2kHz	100Hz

■ MATRIX

The MATRIX allows individual input channels to be assigned to any of the mixer's output channels. The assignments are shown on the display. The initial default settings are: send assignments to all output channels are ON, with only OUT1 assigned to the REC OUT channel. The send levels from individual mono input channels to the output channels can also be adjusted and displayed.

Parameter	Range	Initial value
SEND LEVEL	-∞ – 0dB	0dB

■ Temporary Matrix Assignment Changes

The panel controls can be used to temporarily turn on the output assignments of individual input channels, as follows.

- 1 Set all OUTPUT channel level controls to "0".
- 2 Set the level of the INPUT channel to be assigned to "10".
- 3 Press and hold the MEMORY button corresponding to the output channel you want to assign the input channel to for longer than 3 seconds while rotating the INPUT channel level control towards "0".

Button	Output channel
A	OUTPUT 1
B	OUTPUT 2
C	OUTPUT 3
D	OUTPUT 4

- 4 The corresponding MATRIX indicator will light.
- 5 Repeat for other channels as required.

NOTE

- Output assignments made in this way are only temporary and will not be saved to memory. If power to the unit is turned OFF and then ON again the memorized settings prior to making the changes as described above will be recalled.

■ Feedback Suppressor

The Feedback Suppressor effectively controls feedback by identifying the feedback frequencies that will occur naturally as a result of the combined acoustic and electrical characteristics of the sound system within the acoustic space in which it is used. The Feedback Suppressor includes static filters that provide measurement and filtering for specified channels, and dynamic filters that monitor the condition of specified MONO INPUT channels and automatically suppress feedback as it occurs.

Static filter measurements can be made either via the IMX644 Manager application or the IMX644 unit itself. Measurement from the IMX644 itself is described in “Front Panel Static Filter Measurement” below.

With the initial default settings the static filters are inactive, while the dynamic filters are ON for all MONO INPUT channels.

NOTE

- The initial default setting is Feedback Suppressor ON. Even though the static filters are inactive, the dynamic filters are still operational so be sure to turn the Feedback Suppressor OFF before using sine waves or test tones to test or calibrate the system.
- Feedback Suppressor settings can be stored in the unit’s 16 memories.

Front Panel Static Filter Measurement

To ensure optimum feedback suppression be sure to perform the measurements under the same conditions that will prevail during actual operation (microphone and speaker positions, etc.).

- 1 Set the OUTPUT channel 1 through 4 level controls to 3 o’clock.**
- 2 Set the level control of the MONO INPUT to which the microphone that is to be used for measurement is connected to 3 o’clock.**
- 3 Set up the microphone at least 5 meters away from the speakers.**
- 4 Adjust the output level of the power amplifier.**
While speaking or singing into the microphone gradually raise the output level of the power amplifier to the level that will be used in actual operation. Also clap your hands near the microphone to make sure that feedback does not occur.
- 5 Set the level control of the MONO INPUT channel to which the microphone that is to be used for measurement is connected to “0”.**
- 6 Make sure the area being measured is silent.**

- 7 Simultaneously press and hold MEMORY buttons [A], [C], and [D] for longer than two seconds. The MEMORY [A], [C], and [D] button indicators will light and static filter measurement will begin. When the measurement process has finished the static filter will be set according to the results and the MEMORY button indicators will return to their status prior to the measurement.**

NOTE

- If all four MEMORY button indicators light – [A], [B], [C], and [D] – an error has occurred during measurement. To prevent damage to the equipment the measurement will be aborted and the erroneous data discarded. If this occurs try changing the orientation of the microphone and speakers, lower the amplifier output, then repeat the procedure from step 1 above.
- Static filter measurement may not be successful if the overall level is too high or the microphone is too close to one of the speakers.

■ Priority Ducker

When a signal is applied to the specified MONO INPUT channel the level of all STEREO INPUT signals assigned to the same output are reduced to allow announcements made via the MONO INPUT channel to stand out clearly from background music or other program material, for example. When input to the specified MONO INPUT channel ceases the level of the other “ducked” channels returns to normal.

The initial default setting is OFF for all channels.

Both the amount of attenuation and the time it takes to return to normal level can be programmed as required.

Parameter	Range	Initial value
Mute Level	-30.2dB – 0dB	-20dB
Release Time	0.0 – 6.0sec	2.0sec

■ Music Override

When a signal is applied to the specified STEREO INPUT channel all other STEREO INPUT channels assigned to the same output are automatically faded out and muted. When input to the specified STEREO INPUT channel ceases the level of the other muted channels fades in and returns to normal.

The initial default setting is OFF for all channels.

The time it takes to fade-in to normal level can be programmed as required.

NOTE

- If Music Override is ON for more than one channel, the lowest-numbered channel takes priority.

Parameter	Range	Initial value
Release Time	0.0 – 6.0sec	4.0sec

Output Channels

■ OUTPUT EQ

The parameters of the independent 6-band parametric equalizers provided for OUTPUT channels 1 through 4 can be adjusted and displayed. The following EQ types can be specified for each band.

Type	Parameter	Range
PEQ (Peaking EQ)	F	40Hz – 18kHz
	G	-15dB – +15dB
	Q	0.5 – 12.0
HPF (High Pass Filter)	F	40Hz – 18kHz
	Slope	12dB/oct (Fixed)
	Q	0.7 (Fixed)
LPF (Low Pass Filter)	F	40Hz – 18kHz
	Slope	12dB/oct (Fixed)
	Q	0.7 (Fixed)
L. Shelf (Low Shelving EQ)	F	40Hz – 18kHz
	G	-15dB – +15dB
H.Shelf (High Shelving EQ)	F	40Hz – 18kHz
	G	-15dB – +15dB

The initial default settings when the P.EQ type is selected are as follows.

Parameter	Initial value
Q	0.7 (for all frequency parameters)
F1	40Hz
F2	100Hz
F3	500Hz
F4	2kHz
F5	5kHz
F6	10kHz

■ DELAY

Sets the output channel delay time.

One of the main uses for this feature is to delay the output to sub speakers slightly compared to the main speakers, to create a solid frontal sonic image.

Parameter	Range	Initial value
DELAY	0 – 300msec	0msec

■ BALANCE

Adjusts the A/B level balance for OUTPUT channels 1 and 2.

Parameter	Range	Initial value
BALANCE	0dB – 20.1dB	0dB

■ Output Format (STEREO/MONO)

Specifies whether OUTPUT channels 1 and 2 deliver a STEREO or MONO output signal. When [STEREO] is selected the left channel signal is delivered via the A connector and the right-channel signal is delivered via the B connector. The initial default setting is [STEREO].

Others

■ GPI (General Purpose Interface)

- GPI Input**
 Applying an appropriate input to one of the rear-panel GPI input ports recalls the assigned memory. Individual assignments can be made for each input port.
- GPI Output**
 Recalling a memory causes a pre-assigned combination of ON and OFF outputs to appear at the GPI output ports. The ON/OFF combinations can be independently assigned for each memory.
 The initial default assignments for all memories are all outputs OFF.

■ MEMORY

Up to 16 sets of parameters can be memorized. Of those, four can be assigned for direct recall from the front-panel MEMORY [A] through [D] buttons. For access to five or more memories at a time either use the IMX644 Manager application, or a suitable external controller connected to the GPI interface.

NOTE

- MEMORY buttons [A] through [D] are initially set up to recall the same data.
- Since the level settings for each channel are stored in the IMX644 unit itself, be sure that the IMX644 Manager application is online when setting up the memories.

Appendix

Troubleshooting

Symptom	Possible Cause	Solution
The power won't turn on.	The power cable is not properly connected.	After connecting the power cable to the connector on the rear panel of the IMX644, plug the cable into an appropriate AC outlet.
No sound.	The audio cables are not properly connected.	Check all audio connections.
	Connected devices are not turned ON.	Check to make sure that the power to all connected devices is turned ON.
	Wrong matrix settings.	Check the matrix indicators to make sure that the input and output assignments are correct. If the matrix settings are not appropriate use the IMX644 Manager application to set them as required. Also check the matrix send levels.
	Level settings too low.	Make sure that the panel level controls are set appropriately. If this doesn't produce the desired output check the settings via the IMX644 manager application.
Sound levels don't change when the level knobs are operated.	The LOCK function may be engaged.	Disengage the main LOCK function via the IMX644 panel (page 8), or disengage LOCK for a specific knob via the IMX644 Manager application.
Pressing a MEMORY button results in no change to the settings.	The MEMORY button is not being held long enough.	Press and hold the MEMORY button for longer than two seconds.
	No settings have been saved in memory.	Make the required settings via the IMX644 Manager application, and then save them to the appropriate memory.
	The appropriate memory-to-button assignment has not been made.	Use the IMX644 Manager application to assign the desired memory to the button.
The IMX644 cannot be locked.	The [LOCK] switch hasn't been properly pressed. The LOCK indicator will be off if the controls aren't locked.	Press the [LOCK] switch (page 8). The LOCK indicator will light when the controls are locked.
The [LOCK] switch doesn't work.	The IMX644 has been locked via the IMX644 Manager application.	Make sure that the [LOCK] buttons in the IMX644 Manager BLOCK or INPUT screen are turned on (pages 21 and 24 of the IMX644 Manager owner's manual).
Memory cannot be recalled via the GPI interface.	A memory is not assigned to the GPI input.	Use the IMX644 Manager application to assign the desired memory to the GPI Input Terminal.
The IMX644 cannot be operated from an external controller (AMX/Crestron).	The IMX644 is operating in IMX644 Manager mode.	Turn the IMX644 power OFF, and then after waiting for at least six seconds turn the power ON again (<i>without</i> holding the MEMORY [D] button) to start the IMX644 in "normal" mode.
The IMX644 cannot be operated from the IMX644 Manager application.	The IMX644 is operating in normal mode.	Turn the IMX644 power OFF, and then after waiting for at least six seconds turn the power ON again while holding the MEMORY [D] button to start the IMX644 in "IMX644 Manager" mode.
The Parameter Edit screen will not open when the password is entered via the IMX644 Manager.	The password is incorrect.	Initialize the internal IMX644 memory if the password has been lost or forgotten.

Memory Initialization

The following procedure initializes the IMX644 memory.

⚠ CAUTION

- All data stored in memory will be erased when the memory is initialized. Perform the following procedure with caution.

- 1 Turn the IMX644 power OFF.**
- 2 Turn the power back ON while simultaneously holding the MEMORY [A] and [D] buttons.**
Initialization will take about one second.
When initialization is complete the odd-numbered matrix input channel indicators will light.

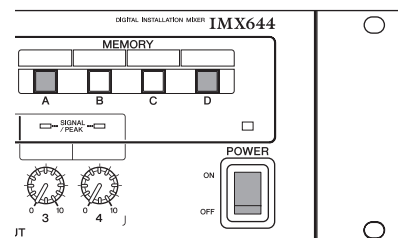

3 To recall the initial memory data press a MEMORY button for longer than two seconds.

NOTE

- Initialization erases the password required to connect the IMX644 Manager application to the IMX644 unit. After initialization it will be necessary to set a new password to bring the IMX644 online.

IMX644 Status List

The chart below shows the panel and memory recall operations that are effective with various combinations of modes, panel LOCK settings, and IMX644 Manager LOCK/LINK settings, and whether the panel or memorized level settings are applied when a memory is recalled.

IMX644 Settings		Individual Channel Settings (IMX644 Manager)		Operations that Affect Actual Level			Operations that Recall Memories					
		[LOCK] indicator	[LOCK] button	[LINK] button	Level Knobs	IMX644 Manager Control	External Controller	MEMORY buttons	GPI	IMX644 Manager Control	External Controller	Level Setting
IMX644 Manager Mode	Offline	unlit	ON	ON	Effective	–	–	Effective	Effective	–	–	Level Knob Setting
		unlit	ON	OFF	Effective	–	–					Memory Setting
		unlit	OFF	ON	Effective	–	–					Level Knob Setting
		unlit	OFF	OFF	Effective	–	–					Memory Setting
		lit	ON	ON	Invalid	–	–	Effective	Effective	–	–	Memory Setting
		lit	ON	OFF	Invalid	–	–					Memory Setting
		lit	OFF	ON	Effective	–	–					Level Knob Setting
		lit	OFF	OFF	Effective	–	–					Memory Setting
	Online*	unlit	ON	ON	Effective	Invalid	–	Effective	Effective	Effective	–	Level Knob Setting
		unlit	ON	OFF	Invalid	Effective	–					Memory Setting
		unlit	OFF	ON	Effective	Invalid	–					Level Knob Setting
		unlit	OFF	OFF	Invalid	Effective	–					Memory Setting
Normal Mode	Effective	unlit	ON	ON	Effective	–	Effective	Effective	Effective	–	Effective	Level Knob Setting
		unlit	ON	OFF	Effective	–	Effective					Memory Setting
		unlit	OFF	ON	Effective	–	Effective					Level Knob Setting
		unlit	OFF	OFF	Effective	–	Effective					Memory Setting
	Effective	Effective	–	Effective	lit	ON	ON	Invalid	–	Effective	Effective	Memory Setting
					lit	ON	OFF	Invalid	–	Effective		Memory Setting
					lit	OFF	ON	Effective	–	Effective		Level Knob Setting
					lit	OFF	OFF	Effective	–	Effective		Memory Setting

* When the IMX644 is online in the IMX644 Manager mode, LOCK is temporarily disengaged and the panel [LOCK] indicator will go out. Do not operate the panel [LOCK] switch in this condition.

NOTE

- Since the level settings for each channel are stored in the IMX644 unit itself, be sure that the IMX644 Manager application is online when setting up the memories.

Remote Control Protocol Specifications

The commands that can be transferred between the IMX644 and a remote controller are as follows.

<Command> <Option 1> <Option 2> ... <Option n> <Line Feed>

- A line feed (LF = 0x0A) is necessary at the end of every command line.
- At least one character space is required between the command name and first option, and between options.

■ Communication Specifications

Baud Rate : 38400 bps

Data : 8bit

Parity : none

Stop Bit : 1bit

Flow Control : none

Memory Recall

Communication Direction	Command
External Controller → IMX644	RSC 0 m
External Controller ← IMX644	RSC OK
External Controller ← IMX644	SCN 0 m
External Controller ← IMX644	VOL 0 0 x
External Controller ← IMX644	VOL 0 1 x
⋮	⋮
External Controller ← IMX644	VOL 0 13 x

Individual Channel Level Control

Communication Direction	Command
External Controller → IMX644	SVL 0 c x
External Controller ← IMX644	SVL OK
External Controller ← IMX644	VOL 0 c x

m: memory number (1–16)

c: channel number (0–13)

x: level value (0–127)

0	MONO 1
1	MONO 2
2	MONO 3
3	MONO 4
4	MONO 5
5	MONO 6
6	STEREO 1
7	STEREO 2
8	STEREO 3
9	STEREO 4
10	OUTPUT1
11	OUTPUT2
12	OUTPUT3
13	OUTPUT4

127	-∞
126	-∞
125	-∞
124	-111.4
123	-102.4
122	-94.4
121	-88.4
120	-83.4
119	-78.4
118	-74.4
117	-70.4
116	-66.4
115	-63.8
114	-60.6
113	-57.6
112	-55.1
111	-52.9
110	-50.9
109	-49.1
108	-47.5
107	-46.0
106	-44.5
105	-43.1
104	-41.7
103	-40.4
102	-39.1

101	-37.9
100	-36.7
99	-35.6
98	-34.5
97	-33.6
96	-32.7
95	-31.8
94	-31.0
93	-30.2
92	-29.4
91	-28.7
90	-28.0
89	-27.3
88	-26.7
87	-26.1
86	-25.5
85	-24.9
84	-24.4
83	-23.9
82	-23.4
81	-22.9
80	-22.4
79	-22.0
78	-21.6
77	-21.2
76	-20.8

75	-20.4
74	-20.0
73	-19.6
72	-19.2
71	-18.8
70	-18.4
69	-18.0
68	-17.6
67	-17.2
66	-16.8
65	-16.4
64	-16.0
63	-15.6
62	-15.2
61	-14.8
60	-14.4
59	-14.0
58	-13.6
57	-13.2
56	-12.8
55	-12.4
54	-12.0
53	-11.6
52	-11.2
51	-10.8
50	-10.4

49	-10.0
48	-9.6
47	-9.2
46	-8.8
45	-8.4
44	-8.0
43	-7.6
42	-7.2
41	-6.8
40	-6.4
39	-6.0
38	-5.6
37	-5.2
36	-4.8
35	-4.4
34	-4.0
33	-3.6
32	-3.2
31	-2.8
30	-2.4
29	-2.0
28	-1.6
27	-1.2
26	-0.8
25	-0.4
24	0.0

23	0.4
22	0.8
21	1.2
20	1.6
19	2.0
18	2.4
17	2.8
16	3.2
15	3.7
14	4.2
13	4.7
12	5.2
11	5.8
10	6.5
9	7.3
8	8.1
7	9.0
6	10.0
5	10.0
4	10.0
3	10.0
2	10.0
1	10.0
0	10.0

General Specifications

Signal Delay	2.5ms (MONO INPUT [1-6] to OUTPUT[1-4])
Dimensions (W x H x D)	480 x 88 x 364.5 mm
Net Weight	5.5kg
Power Requirements	U.S./Canada: 120V, 60Hz Korea: 220V, 60Hz China: 220V, 50Hz Other: 110V-240V, 50/60Hz
Power Consumption	21W
Heat Dissipation	18.06 kcal/h
Temperature range	Operating: 0 to +40°C Storage: -20 to +60°C
Included Accessories	Owner's Manual, AC Power Cord, Rubber feet x 4, 3-pin Euroblock plug x 12
AC Power Cord Length	200 cm

		Conditions	Min.	Typ.	Max.	Unit
Sampling Frequency External Clock	Frequency Range	–	39.69	–	50.88	kHz
Sampling Frequency Internal Clock	Frequency	word clock : int 48kHz	–	48	–	kHz

Input/output Characteristics

ANALOG INPUT CHARACTERISTICS

Input Terminals	PAD 34dB	GAIN	Actual Load Impedance	For Use With Nominal	Input level		Connector
					Nominal	Max. before clip	
MONO INPUT [1-6]	OFF	MAX	4.2kΩ	50-600Ω Mics & 600Ω Lines	-54dBu (1.55mV)	-40dBu (7.75mV)	EUROBLOCK (Balanced) (5.08mm pitch)
		MIN			-30dBu (24.5mV)	-16dBu (123mV)	
	ON	MAX	20kΩ		-20dBu (77.5mV)	-6dBu (387mV)	
		MIN			+4dBu (1.23V)	+18dBu (6.16V)	
STEREO INPUT [1L/R, 2L/R, 3L/R, 4A L/R]	–	–	20kΩ	600Ω Lines	-4dBV (0.631V)	+10dBV (3.16V)	RCA Pin Jack (Unbalanced)

* 0dBu = 0.775 Vrms, 0dBV = 1.00 Vrms.

* +48V DC (phantom power) is supplied to MONO INPUT[1-6] EUROBLOCK connectors via each individual switch.

* All AD converters are 24 bit linear, 64times oversampling.

ANALOG OUTPUT CHARACTERISTICS

Output Terminals	Actual Source Impedance	For Use With Nominal	Output level		Connector
			Nominal	Max. before clip	
OUTPUT [1A/B, 2A/B, 3, 4]	900Ω	10kΩ Lines	+4dBu (1.23V)	+18dBu (6.16V)	EUROBLOCK (Balanced) (5.08mm pitch)
REC OUT [L, R]	450Ω	10kΩ Lines	-4dBV (0.631V)	+10dBV (3.16V)	RCA Pin Jack (Unbalanced)

* 0dBu = 0.775 Vrms, 0dBV = 1.00 Vrms.

* All DA converters are 24 bit linear, 128times oversampling.

DIGITAL INPUT CHARACTERISTICS

Terminal	Format	Data length	Level	Connector
STEREO INPUT [4B]	JEITA CP-1212	24bit	-24 to -14.5dBm *1	OPTICAL Square

*1 0dBm = 1mW

DIGITAL OUTPUT CHARACTERISTICS

Terminal	Format	Data length	Level	Connector
REC OUT	JEITA CP-1212	24bit	-21 to -15dBm *1	OPTICAL Square

*1 0dBm = 1mW

CONTROL I/O CHARACTERISTICS

Terminal	Format	Level	Connector
GPI *1	IN	Mechanical "make" contact	D-SUB 25P (Female)
	OUT	–	
	POWER MONITOR OUTPUT	–	
REMOTE	RS-232C	RS-232C	D-SUB 9P (Male)
USB	USB 1.1 Function	–	Type B

*1 INPUT: 8 ports, OUTPUT: 8 ports

OUTPUT: Withstanding Voltage Vmax = 35V (OFF)

OUTPUT: Sink Current Imax = 30mA/1 port, Imax = 240mA/8 ports (ON)

OUTPUT: Shorted to GND when ON

POWER MONITOR: OPEN (POWER OFF), SHORT (POWER ON)

POWER MONITOR: Withstanding Voltage Vmax = 35V (POWER OFF)

POWER MONITOR: Sink Current Imax = 30mA (POWER ON)

Electrical Characteristics

Output impedance of signal generator : 150 ohms

Frequency Response

20Hz-20kHz, reference to the nominal output level @ 1kHz

Input	Output	RL	Conditions	Min.	Typ.	Max.	Unit
MONO INPUT [1-6]	OUTPUT [1-4]	10KΩ	–	-1.5	0.0	0.5	dB
STEREO INPUT [1L/R-4L/R]	OUTPUT [1-4]	10KΩ	–	-1	0.0	0.5	dB
STEREO INPUT [1L/R-4L/R]	REC OUT [L, R]	10KΩ	–	-1	0.0	0.5	dB
OPTICAL IN	OUTPUT [1-4]	10KΩ	–	-1	0.0	0.5	dB
OPTICAL IN	REC OUT [L, R]	10KΩ	–	-1	0.0	0.5	dB

Total Harmonic Distortion

@ 1kHz

Input	Output	RL	Conditions	Min.	Typ.	Max.	Unit
MONO INPUT [1-6]	OUTPUT [1-4]	10KΩ	+4dBu@1kHz, GAIN: MAX, PAD: OFF	–	–	0.1	%
MONO INPUT [1-6]	OUTPUT [1-4]	10KΩ	+4dBu@1kHz, GAIN: MIN, PAD: ON	–	–	0.08	%
STEREO INPUT [1L/R-4L/R]	OUTPUT [1-4]	10KΩ	+4dBu@1kHz	–	–	0.1	%
STEREO INPUT [1L/R-4L/R]	REC OUT [L, R]	10KΩ	-4dBV@1kHz	–	–	0.1	%

* Total Harmonic Distortion are measured with a 22kHz low pass filter

EIN (EIN=Equivalent Input Noise)

Input	Output	RL	Conditions	Min.	Typ.	Max.	Unit
MONO INPUT [1-6]	OUTPUT [1-4]	10KΩ	Rs=150Ω, GAIN:MAX, PAD: OFF OUTPUT level control at nominal level and one INPUT level control at nominal level.	–	–	-120	dBu

* EIN are measured with a IHF-A filter

Hum & Noise

Input	Output	RL	Conditions	Min.	Typ.	Max.	Unit
–	OUTPUT [1-4]	10KΩ	all level control at minimum level	–	–	-82	dBu
–	REC OUT [L, R]	10KΩ	all level control at minimum level	–	–	-90	dBV

* Hum & Noise are measured with a DIN AUDIO filter

Crosstalk

@ 1kHz

from/to	to/from	Conditions	Min.	Typ.	Max.	Unit
CH N	CH (N-1) or (N+1)	all adjacent inputs	–	–	-70	dB
CH N	CH (N-1) or (N+1)	all adjacent outputs	–	–	-70	dB

Maximum voltage gain

@ 1kHz

Input	Output	RL	Conditions	Min.	Typ.	Max.	Unit
MONO INPUT [1-6]	OUTPUT [1-4]	10KΩ	Rs=150Ω, GAIN: MAX, PAD: OFF	–	58	–	dB
MONO INPUT [1-6]	REC OUT [L, R]	10KΩ	Rs=150Ω, GAIN: MAX, PAD: OFF	–	52.2	–	dB

Phantom Voltage

Output	Conditions	Min.	Typ.	Max.	Unit
MONO INPUT [1-6]	hot & cold: No load	46	48	50	V

Indicator turn on level

Input	Output	Conditions	Min.	Typ.	Max.	Unit
MONO INPUT [1-6] STEREO INPUT [1L/R-4L/R]	–	PEAK red LED: ON	-4	-2	0	dBFS
		SIGNAL green LED: ON	-42	-38	-34	dBFS
–	OUTPUT [3, 4]	PEAK red LED: ON	-4	-2	0	dBFS
		SIGNAL green LED: ON	-48	-44	-40	dBFS

Level Meter turn on level

Input	Output	Conditions	Min.	Typ.	Max.	Unit
–	OUTPUT [1,2]	PEAK red LED: ON	-4	-2	0	dBFS
		-8 orange LED: ON	-10	-8	-6	dBFS
		-14 orange LED: ON	-16	-14	-12	dBFS
		-20 green LED: ON	-22	-20	-18	dBFS
		-32 green LED: ON	-34	-32	-30	dBFS
		-44 green LED: ON	-48	-44	-40	dBFS

GPI Circuit Example

■ Example: Controlling the IMX644 from a switch

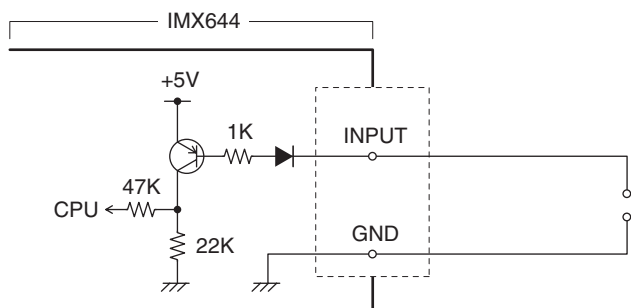

■ Example: Lighting the LED of an external device from the IMX644

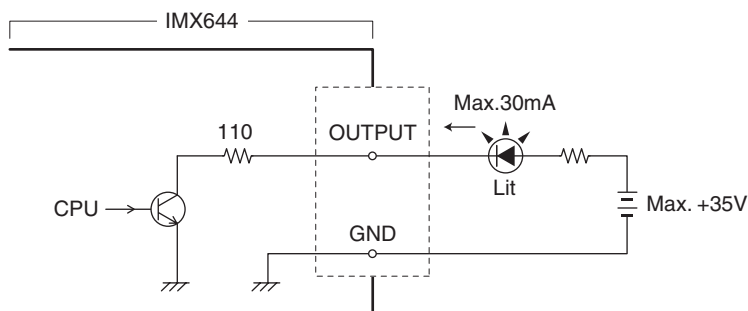

■ Example: Lighting the LED of an external device while the IMX644 power is ON.

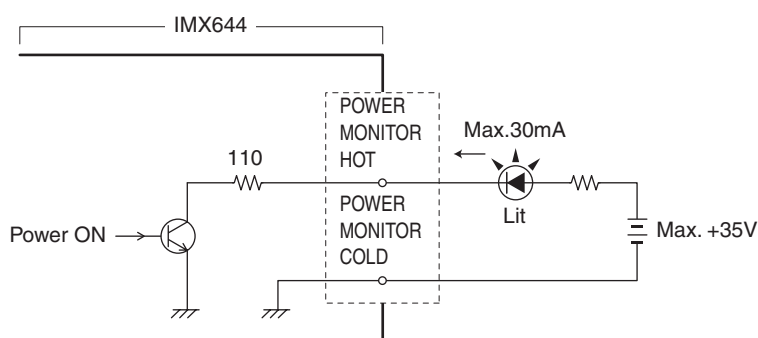

Dimensions

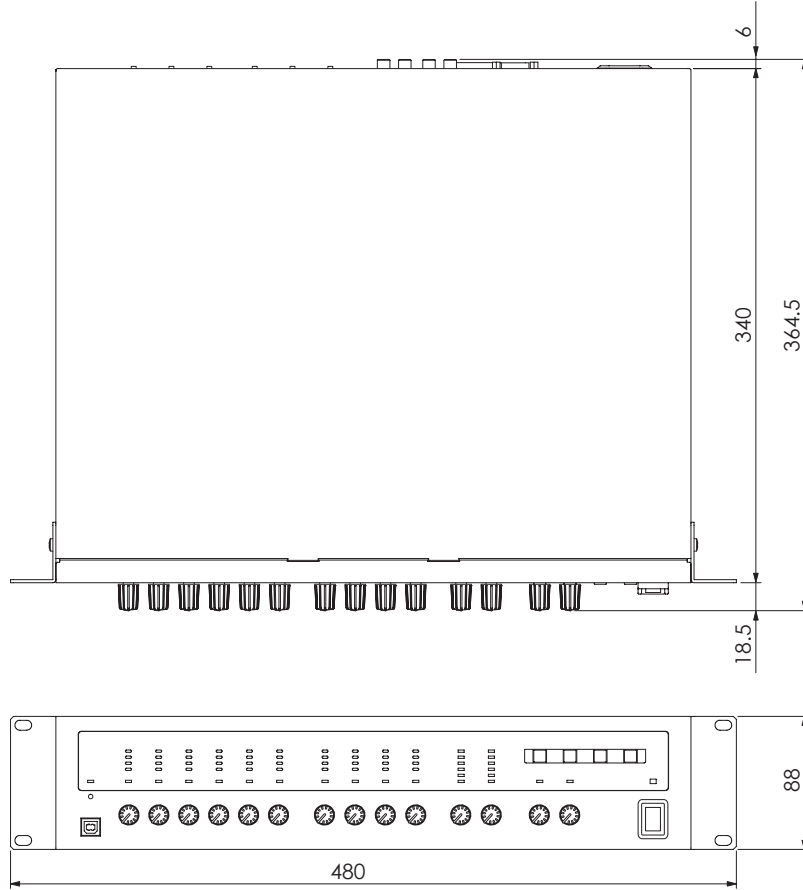

Unit: mm

* Specifications and descriptions in this owner's manual are for information purposes only. Yamaha Corp. reserves the right to change or modify products or specifications at any time without prior notice. Since specifications, equipment or options may not be the same in every locale, please check with your Yamaha dealer.

Block Diagram

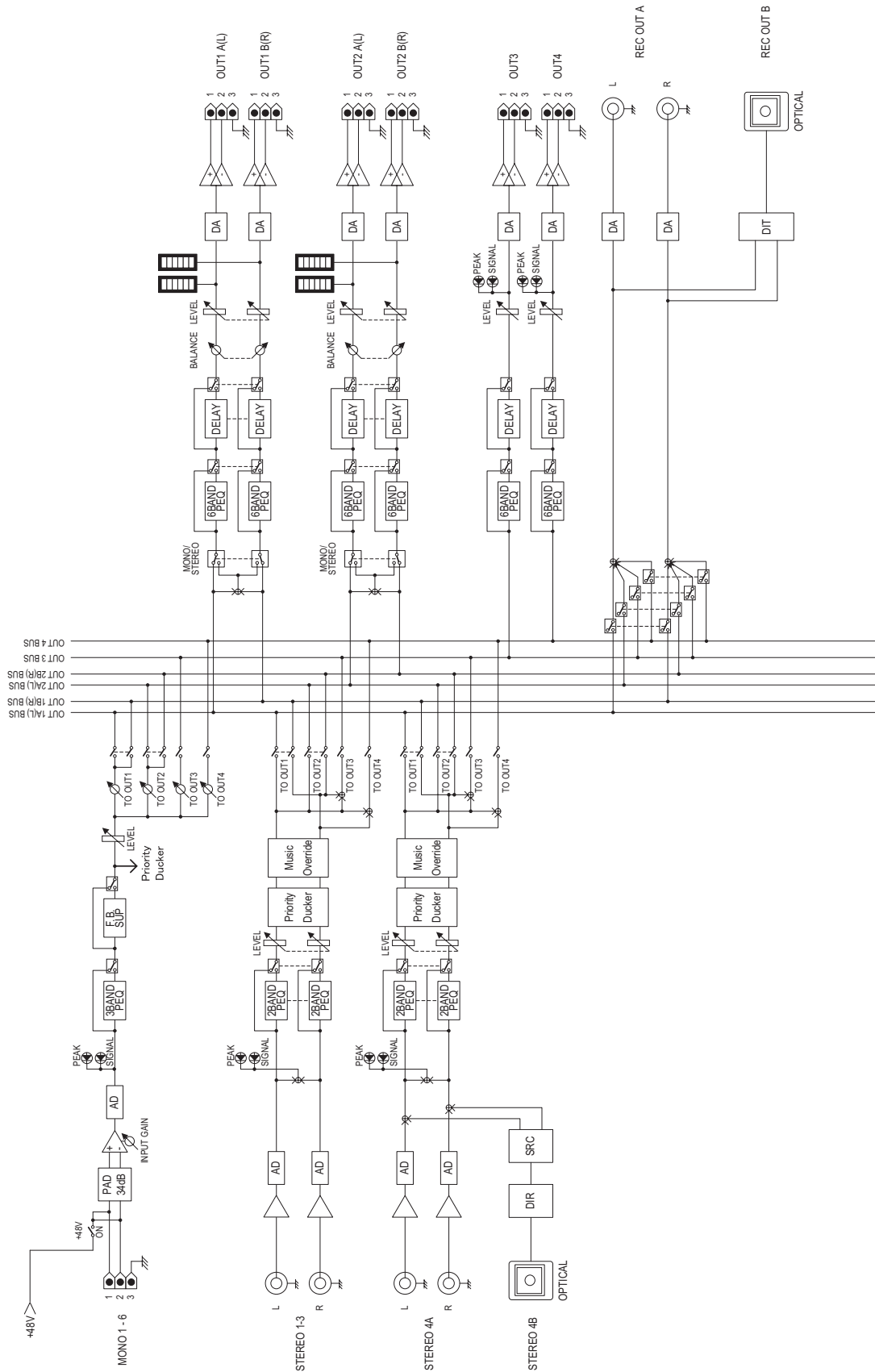

Information for Users on Collection and Disposal of Old Equipment



This symbol on the products, packaging, and/or accompanying documents means that used electrical and electronic products should not be mixed with general household waste. For proper treatment, recovery and recycling of old products, please take them to applicable collection points, in accordance with your national legislation and the Directives 2002/96/EC.

By disposing of these products correctly, you will help to save valuable resources and prevent any potential negative effects on human health and the environment which could otherwise arise from inappropriate waste handling.

For more information about collection and recycling of old products, please contact your local municipality, your waste disposal service or the point of sale where you purchased the items.

[For business users in the European Union]

If you wish to discard electrical and electronic equipment, please contact your dealer or supplier for further information.

[Information on Disposal in other Countries outside the European Union]

This symbol is only valid in the European Union. If you wish to discard these items, please contact your local authorities or dealer and ask for the correct method of disposal.

For details of products, please contact your nearest Yamaha representative or the authorized distributor listed below.

NORTH AMERICA

CANADA

Yamaha Canada Music Ltd.
135 Milner Avenue, Scarborough, Ontario,
M1S 3R1, Canada
Tel: 416-298-1311

U.S.A.

Yamaha Corporation of America
6600 Orangethorpe Ave., Buena Park, Calif. 90620,
U.S.A.
Tel: 714-522-9011

CENTRAL & SOUTH AMERICA

MEXICO

Yamaha de México S.A. de C.V.
Calz. Javier Rojo Gómez #1149,
Col. Guadalupe del Moral
C.P. 09300, México, D.F., México
Tel: 55-5804-0600

BRAZIL

Yamaha Musical do Brasil Ltda.
Rua Joaquim Floriano, 913 - 4º andar, Itaim Bibi,
CEP 04534-013 Sao Paulo, SP. BRAZIL
Tel: 011-3704-1377

ARGENTINA

Yamaha Music Latin America, S.A.
Sucursal de Argentina
Olga Cossetini 1553, Piso 4 Norte
Madero Este-C1107CEK
Buenos Aires, Argentina
Tel: 011-4119-7000

PANAMA AND OTHER LATIN AMERICAN COUNTRIES/ CARIBBEAN COUNTRIES

Yamaha Music Latin America, S.A.
Torre Banco General, Piso 7, Urbanización Marbella,
Calle 47 y Aquilino de la Guardia,
Ciudad de Panamá, Panamá
Tel: +507-269-5311

EUROPE

THE UNITED KINGDOM

Yamaha Music U.K. Ltd.
Sherbourne Drive, Tilbrook, Milton Keynes,
MK7 8BL, England
Tel: 01908-366700

GERMANY

Yamaha Music Europe GmbH
Siemensstraße 22-34, 25462 Rellingen, Germany
Tel: 04101-3030

SWITZERLAND/LIECHTENSTEIN

Yamaha Music Europe GmbH
Branch Switzerland in Zürich
Seefeldstrasse 94, 8008 Zürich, Switzerland
Tel: 01-383 3990

AUSTRIA

Yamaha Music Europe GmbH Branch Austria
Schleiergasse 20, A-1100 Wien, Austria
Tel: 01-60203900

CZECH REPUBLIC/SLOVAKIA/ HUNGARY/SLOVENIA

Yamaha Music Europe GmbH Branch Austria
Schleiergasse 20, A-1100 Wien, Austria
Tel: 01-602039025

POLAND

Yamaha Music Europe GmbH
Branch Sp.z o.o. Oddzial w Polsce
ul. 17 Stycznia 56, PL-02-146 Warszawa, Poland
Tel: 022-868-07-57

THE NETHERLANDS/ BELGIUM/LUXEMBOURG

Yamaha Music Europe Branch Benelux
Clarissenhof 5-b, 4133 AB Vianen, The Netherlands
Tel: 0347-358 040

FRANCE

Yamaha Musique France
BP 70-77312 Marne-la-Vallée Cedex 2, France
Tel: 01-64-61-4000

ITALY

Yamaha Musica Italia S.P.A.
Combo Division
Viale Italia 88, 20020 Lainate (Milano), Italy
Tel: 02-935-771

SPAIN/PORTUGAL

Yamaha Música Ibérica, S.A.
Ctra. de la Coruna km. 17, 200, 28230
Las Rozas (Madrid), Spain
Tel: 91-639-8888

SWEDEN

Yamaha Scandinavia AB
J. A. Wettergrens Gata 1, Box 30053
S-400 43 Göteborg, Sweden
Tel: 031 89 34 00

DENMARK

YS Copenhagen Liaison Office
Generatorvej 6A, DK-2730 Herlev, Denmark
Tel: 44 92 49 00

NORWAY

Norsk filial av Yamaha Scandinavia AB
Grini Næringspark 1, N-1345 Østerås, Norway
Tel: 67 16 77 70

RUSSIA

Yamaha Music (Russia)
Room 37, bld. 7, Kievskaya street, Moscow, 121059,
Russia
Tel: 495 626 5005

OTHER EUROPEAN COUNTRIES

Yamaha Music Europe GmbH
Siemensstraße 22-34, 25462 Rellingen, Germany
Tel: +49-4101-3030

AFRICA

Yamaha Corporation,
Asia-Pacific Sales & Marketing Group
Nakazawa-cho 10-1, Naka-ku, Hamamatsu,
Japan 430-8650
Tel: +81-53-460-2303

MIDDLE EAST

TURKEY/CYPRUS

Yamaha Music Europe GmbH
Siemensstraße 22-34, 25462 Rellingen, Germany
Tel: 04101-3030

OTHER COUNTRIES

Yamaha Music Gulf FZE
LOB 16-513, P.O.Box 17328, Jubel Ali,
Dubai, United Arab Emirates
Tel: +971-4-881-5868

ASIA

THE PEOPLE'S REPUBLIC OF CHINA

Yamaha Music & Electronics (China) Co.,Ltd.
2F, Yunhedasha, 1818 Xinzha-lu, Jingan-qu,
Shanghai, China
Tel: 021-6247-2211

INDIA

Yamaha Music India Pvt. Ltd.
5F Ambience Corporate Tower Ambience Mall Complex
Ambience Island, NH-8, Gurgaon-122001, Haryana, India
Tel: 0124-466-5551

INDONESIA

PT. Yamaha Music Indonesia (Distributor)
PT. Nusantara
Gedung Yamaha Music Center, Jalan Jend. Gatot
Subroto Kav. 4, Jakarta 12930, Indonesia
Tel: 21-520-2577

KOREA

Yamaha Music Korea Ltd.
8F, 9F, Dongsung Bldg. 158-9 Samsung-Dong,
Kangnam-Gu, Seoul, Korea
Tel: 080-004-0022

MALAYSIA

Yamaha Music Malaysia, Sdn., Bhd.
Lot 8, Jalan Perbandaran, 47301 Kelana Jaya,
Petaling Jaya, Selangor, Malaysia
Tel: 3-78030900

SINGAPORE

Yamaha Music Asia Pte., Ltd.
#03-11 A-Z Building
140 Paya Lebar Road, Singapore 409015
Tel: 747-4374

TAIWAN

Yamaha KHS Music Co., Ltd.
3F, #6, Sec.2, Nan Jing E. Rd. Taipei.
Taiwan 104, R.O.C.
Tel: 02-2511-8688

THAILAND

Siam Music Yamaha Co., Ltd.
4, 6, 15 and 16th floor, Siam Motors Building,
891/1 Rama 1 Road, Wangmai,
Pathumwan, Bangkok 10330, Thailand
Tel: 02-215-2626

OTHER ASIAN COUNTRIES

Yamaha Corporation,
Asia-Pacific Sales & Marketing Group
Nakazawa-cho 10-1, Naka-ku, Hamamatsu,
Japan 430-8650
Tel: +81-53-460-2303

OCEANIA

AUSTRALIA

Yamaha Music Australia Pty. Ltd.
Level 1, 99 Queensbridge Street, Southbank,
Victoria 3006, Australia
Tel: 3-9693-5111

COUNTRIES AND TRUST TERRITORIES IN PACIFIC OCEAN

Yamaha Corporation,
Asia-Pacific Sales & Marketing Group
Nakazawa-cho 10-1, Naka-ku, Hamamatsu,
Japan 430-8650
Tel: +81-53-460-2303

HEAD OFFICE **Yamaha Corporation, Pro Audio Division**
Nakazawa-cho 10-1, Naka-ku, Hamamatsu, Japan 430-8650
Tel: +81-53-460-2441



Yamaha Pro Audio global web site:
<http://www.yamahaproaudio.com/>
Yamaha Manual Library
<http://www.yamaha.co.jp/manual/>

U.R.G., Pro Audio Division
© 2008 Yamaha Corporation

LST0803-001B 008AP-02B0

Free Manuals Download Website

<http://myh66.com>

<http://usermanuals.us>

<http://www.somanuals.com>

<http://www.4manuals.cc>

<http://www.manual-lib.com>

<http://www.404manual.com>

<http://www.luxmanual.com>

<http://aubethermostatmanual.com>

Golf course search by state

<http://golfingnear.com>

Email search by domain

<http://emailbydomain.com>

Auto manuals search

<http://auto.somanuals.com>

TV manuals search

<http://tv.somanuals.com>