



DIGITAL PIANO

H01

Owner's Manual
Bedienungsanleitung
Mode d'emploi
Manual de instrucciones

ENGLISH

DEUTSCH

FRANÇAIS

ESPAÑOL

EN
DE
FR
ES

SPECIAL MESSAGE SECTION

PRODUCT SAFETY MARKINGS: Yamaha electronic products may have either labels similar to the graphics shown below or molded/stamped facsimiles of these graphics on the enclosure. The explanation of these graphics appears on this page. Please observe all cautions indicated on this page and those indicated in the safety instruction section.

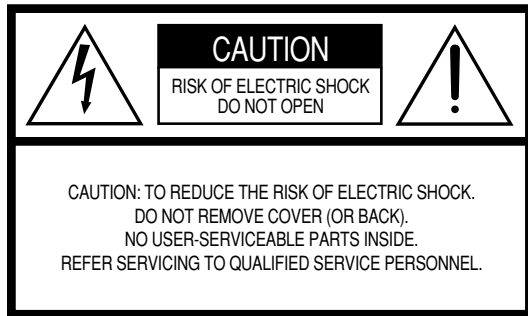

See bottom of Keyboard enclosure for graphic symbol markings.



The exclamation point within the equilateral triangle is intended to alert the user to the presence of important operating and maintenance (servicing) instructions in the literature accompanying the product.

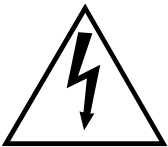

The lightning flash with arrowhead symbol, within the equilateral triangle, is intended to alert the user to the presence of uninsulated “dangerous voltage” within the product’s enclosure that may be of sufficient magnitude to constitute a risk of electrical shock.

IMPORTANT NOTICE: All Yamaha electronic products are tested and approved by an independent safety testing laboratory in order that you may be sure that when it is properly installed and used in its normal and customary manner, all foreseeable risks have been eliminated. **DO NOT** modify this unit or commission others to do so unless specifically authorized by Yamaha. Product performance and/or safety standards may be diminished. Claims filed under the expressed warranty may be denied if the unit is/has been modified. Implied warranties may also be affected.

SPECIFICATIONS SUBJECT TO CHANGE: The information contained in this manual is believed to be correct at the time of printing. However, Yamaha reserves the right to change or modify any of the specifications without notice or obligation to update existing units.

ENVIRONMENTAL ISSUES: Yamaha strives to produce products that are both user safe and environmentally friendly. We sincerely believe that our products and the production methods used to produce them, meet these goals. In keeping with both the letter and the spirit of the law, we want you to be aware of the following:

Battery Notice: This product **MAY** contain a small non-rechargeable battery which (if applicable) is soldered in place. The average life span of this type of battery is approximately five years. When replacement becomes necessary, contact a qualified service representative to perform the replacement.

Warning: Do not attempt to recharge, disassemble, or incinerate this type of battery. Keep all batteries away from children. Dispose of used batteries promptly and as regulated by applicable laws. Note: In some areas, the servicer is required by law to return the defective parts. However, you do have the option of having the servicer dispose of these parts for you.

Disposal Notice: Should this product become damaged beyond repair, or for some reason its useful life is considered to be at an end, please observe all local, state, and federal regulations that relate to the disposal of products that contain lead, batteries, plastics, etc.

NOTICE: Service charges incurred due to lack of knowledge relating to how a function or effect works (when the unit is operating as designed) are not covered by the manufacturer’s warranty, and are therefore the owners responsibility. Please study this manual carefully and consult your dealer before requesting service.

NAME PLATE LOCATION: The graphic below indicates the location of the name plate. The model number, serial number, power requirements, etc., are located on this plate. You should record the model number, serial number, and the date of purchase in the spaces provided below and retain this manual as a permanent record of your purchase.

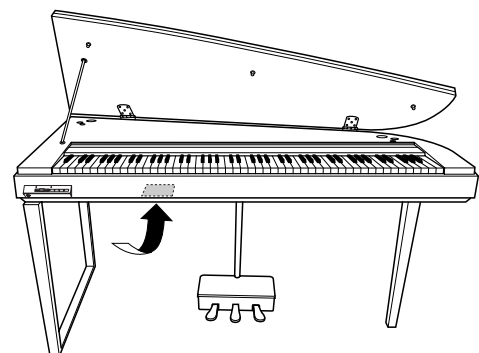

Model _____

Serial No. _____

Purchase Date _____

IMPORTANT SAFETY INSTRUCTIONS

INFORMATION RELATING TO PERSONAL INJURY, ELECTRICAL SHOCK, AND FIRE HAZARD POSSIBILITIES HAS BEEN INCLUDED IN THIS LIST.

WARNING- When using any electrical or electronic product, basic precautions should always be followed. These precautions include, but are not limited to, the following:

1. Read all Safety Instructions, Installation Instructions, Special Message Section items, and any Assembly Instructions found in this manual **BEFORE** making any connections, including connection to the main supply.
2. **Main Power Supply Verification:** Yamaha products are manufactured specifically for the supply voltage in the area where they are to be sold. If you should move, or if any doubt exists about the supply voltage in your area, please contact your dealer for supply voltage verification and (if applicable) instructions. The required supply voltage is printed on the name plate. For name plate location, please refer to the graphic found in the Special Message Section of this manual.
3. This product may be equipped with a polarized plug (one blade wider than the other). If you are unable to insert the plug into the outlet, turn the plug over and try again. If the problem persists, contact an electrician to have the obsolete outlet replaced. Do **NOT** defeat the safety purpose of the plug.
4. Some electronic products utilize external power supplies or adapters. Do **NOT** connect this type of product to any power supply or adapter other than one described in the owners manual, on the name plate, or specifically recommended by Yamaha.
5. **WARNING:** Do not place this product or any other objects on the power cord or place it in a position where anyone could walk on, trip over, or roll anything over power or connecting cords of any kind. The use of an extension cord is not recommended! If you must use an extension cord, the minimum wire size for a 25' cord (or less) is 18 AWG. **NOTE:** The smaller the AWG number, the larger the current handling capacity. For longer extension cords, consult a local electrician.
6. **Ventilation:** Electronic products, unless specifically designed for enclosed installations, should be placed in locations that do not interfere with proper ventilation. If instructions for enclosed installations are not provided, it must be assumed that unobstructed ventilation is required.
7. **Temperature considerations:** Electronic products should be installed in locations that do not significantly contribute to their operating temperature. Placement of this product close to heat sources such as; radiators, heat registers and other devices that produce heat should be avoided.
8. This product was **NOT** designed for use in wet/damp locations and should not be used near water or exposed to rain. Examples of wet/damp locations are; near a swimming pool, spa, tub, sink, or wet basement.
9. This product should be used only with the components supplied or; a cart, rack, or stand that is recommended by the manufacturer. If a cart, rack, or stand is used, please observe all safety markings and instructions that accompany the accessory product.
10. The power supply cord (plug) should be disconnected from the outlet when electronic products are to be left unused for extended periods of time. Cords should also be disconnected when there is a high probability of lightning and/or electrical storm activity.
11. Care should be taken that objects do not fall and liquids are not spilled into the enclosure through any openings that may exist.
12. Electrical/electronic products should be serviced by a qualified service person when:
 - a. The power supply cord has been damaged; or
 - b. Objects have fallen, been inserted, or liquids have been spilled into the enclosure through openings; or
 - c. The product has been exposed to rain; or
 - d. The product does not operate, exhibits a marked change in performance; or
 - e. The product has been dropped, or the enclosure of the product has been damaged.
13. Do not attempt to service this product beyond that described in the user-maintenance instructions. All other servicing should be referred to qualified service personnel.
14. This product, either alone or in combination with an amplifier and headphones or speaker/s, may be capable of producing sound levels that could cause permanent hearing loss. **DO NOT** operate for a long period of time at a high volume level or at a level that is uncomfortable. If you experience any hearing loss or ringing in the ears, you should consult an audiologist. **IMPORTANT:** The louder the sound, the shorter the time period before damage occurs.
15. Some Yamaha products may have benches and/or accessory mounting fixtures that are either supplied as a part of the product or as optional accessories. Some of these items are designed to be dealer assembled or installed. Please make sure that benches are stable and any optional fixtures (where applicable) are well secured **BEFORE** using. Benches supplied by Yamaha are designed for seating only. No other uses are recommended.

PLEASE KEEP THIS MANUAL

92-469-2

PRECAUTIONS

PLEASE READ CAREFULLY BEFORE PROCEEDING

* Please keep this manual in a safe place for future reference.

WARNING

Always follow the basic precautions listed below to avoid the possibility of serious injury or even death from electrical shock, short-circuiting, damages, fire or other hazards. These precautions include, but are not limited to, the following:

Power supply/Power cord

- Only use the voltage specified as correct for the instrument. The required voltage is printed on the name plate of the instrument.
- Check the electric plug periodically and remove any dirt or dust which may have accumulated on it.
- Use only the supplied power cord/plug.
- Do not place the power cord near heat sources such as heaters or radiators, and do not excessively bend or otherwise damage the cord, place heavy objects on it, or place it in a position where anyone could walk on, trip over, or roll anything over it.

Do not open

- Do not open the instrument or attempt to disassemble the internal parts or modify them in any way. The instrument contains no user-serviceable parts. If it should appear to be malfunctioning, discontinue use immediately and have it inspected by qualified Yamaha service personnel.

Water warning

- Do not expose the instrument to rain, use it near water or in damp or wet conditions, or place containers on it containing liquids which might spill into any openings.
- Never insert or remove an electric plug with wet hands.

Fire warning

- Do not put burning items, such as candles, on the unit. A burning item may fall over and cause a fire.

If you notice any abnormality

- If the power cord or plug becomes frayed or damaged, or if there is a sudden loss of sound during use of the instrument, or if any unusual smells or smoke should appear to be caused by it, immediately turn off the power switch, disconnect the electric plug from the outlet, and have the instrument inspected by qualified Yamaha service personnel.

CAUTION

Always follow the basic precautions listed below to avoid the possibility of physical injury to you or others, or damage to the instrument or other property. These precautions include, but are not limited to, the following:

Power supply/Power cord

- When removing the electric plug from the instrument or an outlet, always hold the plug itself and not the cord. Pulling by the cord can damage it.
- Remove the electric plug from the outlet when the instrument is not to be used for extended periods of time, or during electrical storms.
- Do not connect the instrument to an electrical outlet using a multiple-connector. Doing so can result in lower sound quality, or possibly cause overheating in the outlet.

Assembly

- Read carefully the attached documentation explaining the assembly process. Failure to assemble the instrument in the proper sequence might result in damage to the instrument or even injury.

Location

- Do not expose the instrument to excessive dust or vibrations, or extreme cold or heat (such as in direct sunlight, near a heater, or in a car during the day) to prevent the possibility of panel disfiguration or damage to the internal components.
- Do not use the instrument in the vicinity of a TV, radio, stereo equipment, mobile phone, or other electric devices. Otherwise, the instrument, TV, or radio may generate noise.
- Do not place the instrument in an unstable position where it might accidentally fall over.
- Before moving the instrument, remove all connected cables.
- When setting up the product, make sure that the AC outlet you are using is easily accessible. If some trouble or malfunction occurs, immediately turn off the power switch and disconnect the plug from the outlet. Even when the power switch is turned off, electricity is still flowing to the product at the minimum level. When you are not using the product for a long time, make sure to unplug the power cord from the wall AC outlet.

Connections

- Before connecting the instrument to other electronic components, turn off the power for all components. Before turning the power on or off for all components, set all volume levels to minimum. Also, be sure to set the volumes of all components at their minimum levels and gradually raise the volume controls while playing the instrument to set the desired listening level.

Maintenance

- In the case of a model with a polished finish, gently remove dust and dirt with a soft cloth. Do not wipe too hard since small particles of dirt can scratch the instrument's finish.
- When cleaning the instrument, use a soft, dry or slightly damp cloth. Do not use paint thinners, solvents, cleaning fluids, or chemical-impregnated wiping cloths.

Handling caution

- Take care that the key cover does not pinch your fingers, and do not insert a finger or hand in any gaps on the key cover or instrument.
- Never insert or drop paper, metallic, or other objects into the gaps on the key cover, panel or keyboard. If this happens, turn off the power immediately and unplug the power cord from the AC outlet. Then have the instrument inspected by qualified Yamaha service personnel.
- Do not place vinyl, plastic or rubber objects on the instrument, since this might discolor the panel or keyboard.
- In the case of a model with a polished finish, bumping the surface of the instrument with metal, porcelain, or other hard objects can cause the finish to crack or peel. Use caution.
- Do not rest your weight on, or place heavy objects on the instrument, and do not use excessive force on the buttons, switches or connectors.
- Do not use the instrument/device or headphones for a long period of time at a high or uncomfortable volume level, since this can cause permanent hearing loss. If you experience any hearing loss or ringing in the ears, consult a physician.

Yamaha cannot be held responsible for damage caused by improper use or modifications to the instrument, or data that is lost or destroyed.

Always turn the power off when the instrument is not in use.

- * The illustrations as shown in this owner's manual are for instructional purposes only, and may appear somewhat different from those on your instrument.
- * Copying of the commercially available musical data including but not limited to MIDI data and/or audio data is strictly prohibited except for your personal use.

This product incorporates and bundles computer programs and contents in which Yamaha owns copyrights or with respect to which it has license to use others' copyrights. Such copyrighted materials include, without limitation, all computer software, style files, MIDI files, WAVE data, musical scores and sound recordings. Any unauthorized use of such programs and contents outside of personal use is not permitted under relevant laws. Any violation of copyright has legal consequences. **DON'T MAKE, DISTRIBUTE OR USE ILLEGAL COPIES.**

- The company names and product names in this Owner's Manual are the trademarks or registered trademarks of their respective companies.

Using the bench (If included)

- Do not place the bench in an unstable position where it might accidentally fall over.
- Do not play carelessly with or stand on the bench. Using it as a tool or step-ladder or for any other purpose might result in accident or injury.
- Only one person should sit on the bench at a time, in order to prevent the possibility of accident or injury.
- If the bench screws become loose due to extensive long-term use, tighten them periodically using the included tool.

Saving data

Backing up the USB storage device

- To protect against data loss through media damage, we recommend that you save your important data onto two USB storage devices.

Introduction

Thank you for purchasing the Yamaha Digital Piano H01!

We recommend that you read this manual carefully so that you can fully take advantage of the advanced and convenient functions of the H01.

We also recommend that you keep this manual in a safe and handy place for future reference.

Main Features

■ Stylish and sophisticated digital piano

The H01 combines true piano sound in a modern, attractive cabinet that evokes the beauty of a real acoustic grand piano—adding sophistication and musical expressiveness to your living space.

■ Authentic Acoustic Piano—like Touch Natural Wood Keyboard

The special Natural Wood keyboard uses real wood (on the white keys), to reproduce as closely as possible the experience of playing an actual acoustic grand piano. The authentic touch and feel of the keys goes far beyond existing electronic keyboards, realistically recreating the hardness of the keys, the balance between the weight of the key and hammer, and the characteristic weight gradations of the keys—heavy in the low end, light in the high register—to make you feel as if you're playing a real grand piano. Moreover, this specially crafted keyboard lets you use techniques only possible on grand pianos, such as playing the same note successively and having the sounds blend smoothly even without use of the damper pedal, or playing the same key quickly and having perfect articulation without the sound cutting off unnaturally.

■ AWM Dynamic Stereo Sampling

The Yamaha H01 offers unmatched sonic realism and natural grand-piano type playability as well as Yamaha's original AWM Dynamic Stereo Sampling tone generation technology for rich, musical voices.

The Grand Piano 1 feature totally new samples painstakingly recorded from a full concert grand piano.

And the voice feature three velocity-switched samples (Dynamic Sampling), special Sustain Sampling (page 15) that samples the unique resonance of an acoustic grand piano's soundboard and strings when the sustain pedal is pressed, and Keyoff Samples that add the subtle sound produced when the keys are released. The H01 comes much closer to the sound of a true acoustic piano.

Accessories

- Owner's Manual

This manual contains complete instructions for operating your H01.

- Quick Operation Guide

- Bench (included or optional depending on local)

Table of Contents

Introduction

Main Features.....	6
Accessories	6
Panel Controls and Terminals.....	8
Before Using the H01	9
Opening the key cover and lid	9
Closing the key cover and lid	9
Turning the Power On	10
Setting the Volume	10
Using Headphones	10

Reference

Listening to the 50 Piano Preset Songs.....	11
Listening to songs in the USB Flash Memory.....	12
USB Flash Memory.....	13
Specify the Song Track and Play the Song.....	14
Selecting & Playing Voices.....	15
Selecting Voices	15
Using the Pedals.....	16
Combining Voices (Dual).....	17
Adding Variations to the Sound – Reverb	18
Transposition.....	19
Fine tuning of the Pitch.....	19
Touch Sensitivity	20
Troubleshooting.....	21
Keyboard Stand Assembly	22

Appendix

Song List.....	26
Specifications	27
Optional Equipment.....	27

Panel Controls and Terminals

ENGLISH

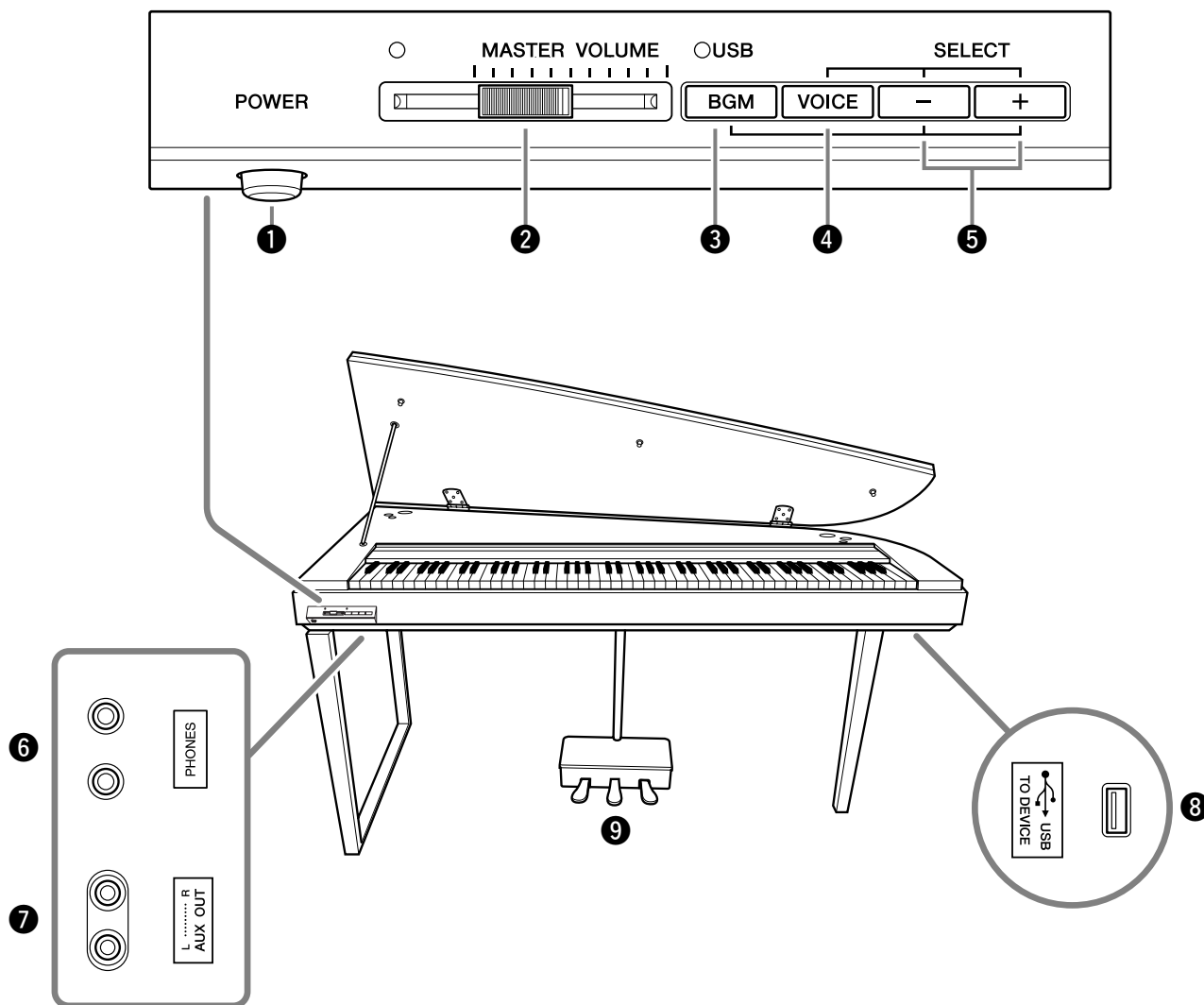

- 1 [POWER] switch** page 10
For turning the power on or off.
- 2 [MASTER VOLUME] slider** page 10
For adjusting the volume level of the entire sound.
- 3 [BGM] button**pages 11, 12, 14, 19
For playing the 50 piano preset songs.
- 4 [VOICE] button** pages 14, 15, 17–20
For selecting voices from 10 internal sounds including Grand Piano 1 and 2 (page 15). You can also combine two voices (page 17) or add reverb effects to the selected voice for your keyboard performance (page 18).
- 5 SELECT [-]/[+] buttons**....pages 11, 12, 15
For selecting a song (page 11) or a voice (page 15).
- 6 [PHONES] jack**..... page 10
For connecting a set of stereo headphones, allowing private practice.
- 7 [AUX OUT] jack**
For outputting the sound of the instrument to an external audio system.
- 8 [USB TO DEVICE] terminal** page 12
For connecting a USB storage device and playing song data from the device.
- 9 Pedals**..... page 16
For producing a range of expressive effects similar to those produced by the pedals on an acoustic piano.

Before Using the H01

Opening the key cover and lid

1. Lift open the key cover and fold it backward.

⚠ CAUTION

Hold the cover with both hands when opening or closing it.

⚠ CAUTION

Do not release the cover until it is fully folded back or closed.

⚠ CAUTION

Be careful to avoid catching your fingers (yours or others, especially children's) when opening the cover.

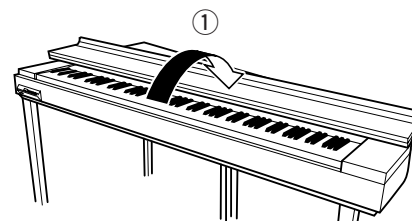

2. Raise and hold the lid up as shown.

⚠ CAUTION

Raising the lid past the normal height can result in damage to the instrument.

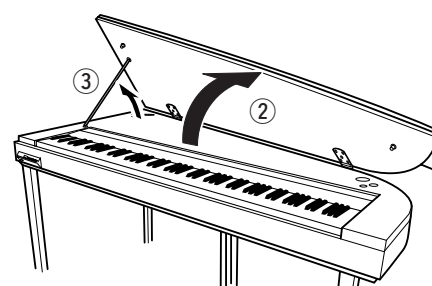
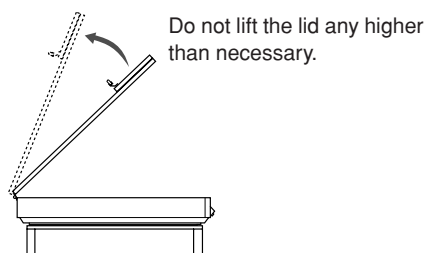

3. Raise the lid stay and carefully lower the lid so that the end of the stay fits into the recess in the lid and holds it in place.

Closing the key cover and lid

1. Hold the lid stay and carefully raise the lid.
2. Hold the lid in its raised position and lower the lid stay.
3. Carefully lower the lid.
4. Close the key cover.

⚠ CAUTION

Be careful to avoid catching your fingers (yours or others, especially children's) when opening the cover.

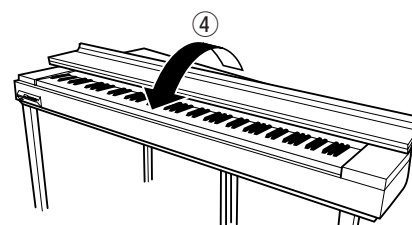
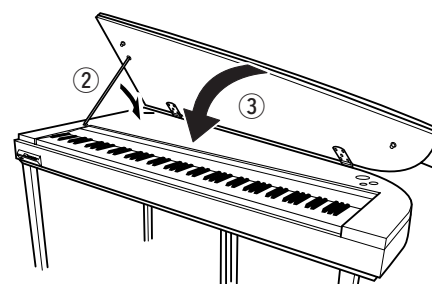

Turning the Power On

1. Insert the plug of the power cable into the AC connector on the instrument, then plug the other end of the cable into the proper AC outlet on the wall.

CAUTION

Never interrupt the power supply during the instrument load operation! Doing so can result in loss of data.

2. Press the [POWER] switch to turn the power on.

The power indicator located to the right of the [POWER] switch lights up.

NOTE

All current panel settings will be changed to the initial settings when turning the power off and on.

CAUTION

Never interrupt the power supply while the instrument is loading data from a USB device! Doing so can result in loss of data.

CAUTION

Even when the instrument is turned off, electricity is still flowing to the instrument at the minimum level. When you are not using the H01 for a long time or during electrical storms, make sure you unplug the AC power plug from the wall AC outlet.

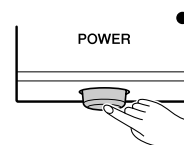
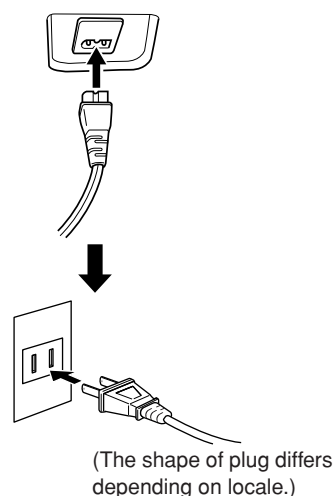

Setting the Volume

Initially set the [MASTER VOLUME] slider about halfway between the “MIN” and “MAX” settings. Then, when you start playing, re-adjust the [MASTER VOLUME] slider to the most comfortable listening level.

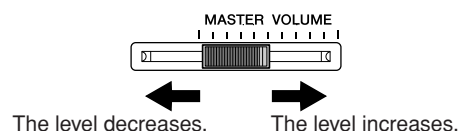

TERMINOLOGY

MASTER VOLUME:

The volume level of the entire keyboard sound.

Using Headphones

Connect a set of headphones to one of the [PHONES] jacks.

Two [PHONES] jacks are provided. You can connect two sets of stereo headphones. (If you are using only one set of headphones, you can plug them into either jack.) It can also connect to an amplifier/speaker system.

CAUTION

To protect your hearing, avoid listening to the H01 at a high volume level for long periods of time.

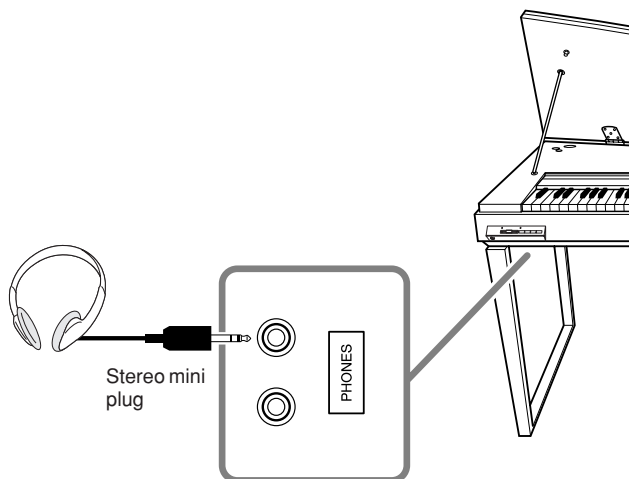

Listening to the 50 Piano Preset Songs

The H01 features a variety of preset songs specially recorded to showcase the capabilities of the instrument.

1. Press the [POWER] switch to turn the power on.

When the power is turned ON, the power indicator located to the right of the [POWER] switch lights up.

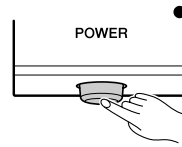

2. Adjust the volume.

Initially set the [MASTER VOLUME] slider about half way between the “MIN” and “MAX” settings. Then, when you start playing, re-adjust the [MASTER VOLUME] slider to the most comfortable listening level.

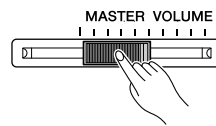

3. Listen the preset songs.

Listening to the preset songs in random order

Press the [BGM] button to play the songs in random order.

Press the **SELECT [-]/[+]** button to jump to the next song in random order.



Selecting and listening to a favorite preset song

You can select and play a favorite song.

Press one of the C2–C#6 keys while holding down the [BGM] button. Refer to the “Song List” on page 26 for a list of the preset song names and the corresponding keys for selecting them.

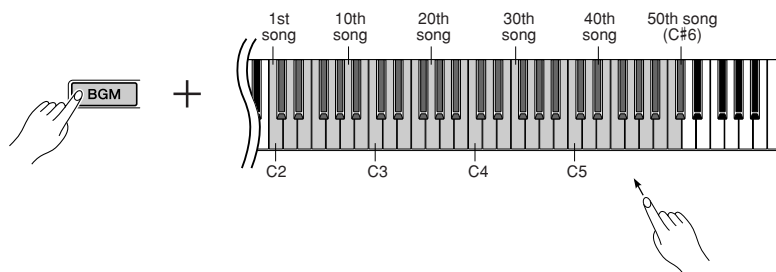

Selecting a favorite scene and listening to the songs

Preset songs are also divided into scene categories (for different music listening preferences). While holding down the [BGM] button, press one of the C0–C1 keys to select a favorite scene. Press the **SELECT [-]/[+]** button to jump to the next song in the selected scene.

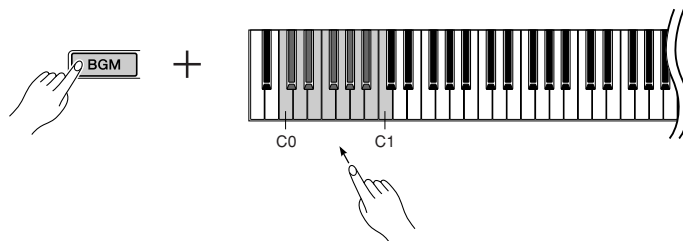

4. Press the [BGM] button to stop playback.



TERMINOLOGY

Song:

On the H01, performance data is called a “Song.”

Preset:

Preset Data supplied with the internal memory of the H01 shipped from the factory.

TERMINOLOGY

Random order:

The 50 Piano songs are selected and played back randomly by the instrument—similar to the shuffling of a deck of cards—when pressing the [BGM] button.



The 50 Piano Preset songs cannot be played when a USB storage device is connected to the [USB DEVICE] terminal.

For safety's sake, when you disconnect a USB device, make sure to wait for at least six seconds before reconnecting it.

TERMINOLOGY

Scene:

The 50 Piano Preset songs have been divided into thirteen groups or categories, to match a variety of listening preferences and to let you select your favorite songs based on a scene description. For instance, if you want to listen to some “Elegant” songs, select scene number 4. The songs that match that category will play sequentially.

Scene Titles:

1. Home Party
2. Morning
3. Upbeat
4. Elegant
5. Relaxing
6. Nighttime
7. Melancholy
8. Mood Music
9. Fantasy
10. Baroque and Pre-romantic Music
11. Pre-romantic (Chopin)
12. Post-romantic
13. Modern French

Listening to songs in the USB Flash Memory

Save the song data to a USB storage device by using the computer and then connect the device to the instrument. The song data can be automatically loaded.

⚠ CAUTION

While loading the data from USB Flash Memory (LED flashes) or playing the USB song, never pull out the device or turn the power off. Doing so can result in a loss of data.

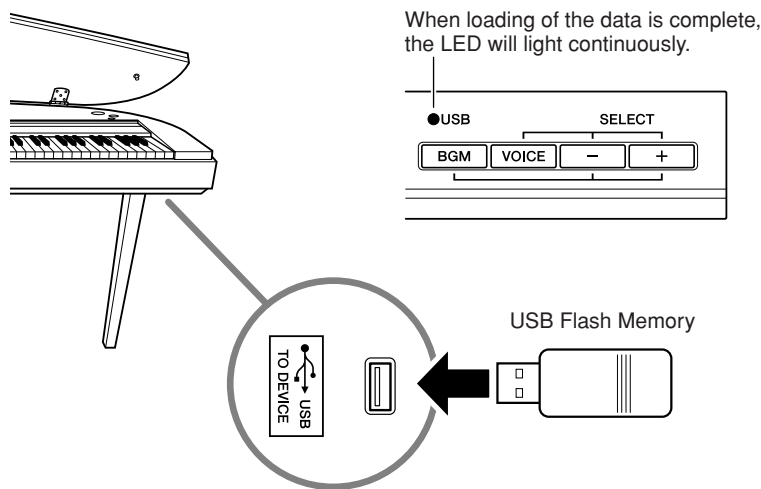

1. Start/Stop the song.

Press the [BGM] button to play the songs in random order.

USB song data can be played back only in random order.



Certain songs may take more time than others to start playback. Keep in mind that this also affects the time between playback of successively played songs.

2. Press the SELECT [-]/[+] button to jump to the next song in random order.

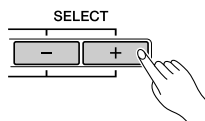

If you don't have a USB flash memory, you will need to purchase one (or more, as needed). The instrument does not necessarily support all commercially available USB storage devices. Yamaha cannot guarantee operation of USB storage devices that you purchase. Before purchasing USB storage devices, please consult your Yamaha dealer, or an authorized Yamaha distributor (see list at end of the Owner's Manual) for advice.

Data format

This instrument can play back SMF Format 0 (Standard MIDI file) and DOC (Disk Orchestra Collection) song data.

When copying song data from computer to USB flash memory, make sure to save it by using SMF Format 0.

Keep in mind that songs recorded on other devices may use a variety of voices not available on this instrument and hence may sound different than the original songs. In general, this instrument should be used to play back piano songs.

TERMINOLOGY

What is SMF (Standard MIDI File)?

The SMF (Standard MIDI File) format is one of the most common and widely compatible sequence formats used for storing sequence data. There are two variations: Format 0 and Format 1. A large number of MIDI devices are compatible with SMF Format 0, and most commercially available MIDI sequence data is provided in SMF Format 0.

USB Flash Memory

To protect your data (write-protect switch)

Even though this instrument does not have a save operation and data cannot be saved to a USB storage device, there is still a possibility of data loss caused by improper use (for example, turning the power off while loading data, etc.).

Some USB flash memory devices are equipped with a write-protect switch. To prevent accidental erasure of important data saved in USB flash memory, slide the write-protect switch on the device to the “protect” position. When saving data, make sure that the write-protect switch is set to the “overwrite” position.

To connect the USB Flash Memory

Connect the USB Flash Memory device with the proper orientation; do not force a wrong connection.

IMPORTANT

The playing songs copied to a USB flash memory from a computer or other device, the songs must be stored either in the USB flash memory’s root directory or a first-level/second-level folder in the root directory. Songs stored in these location can be played as song data.

Songs stored in third-level-folders created inside a second-level folder cannot be played by this instrument.

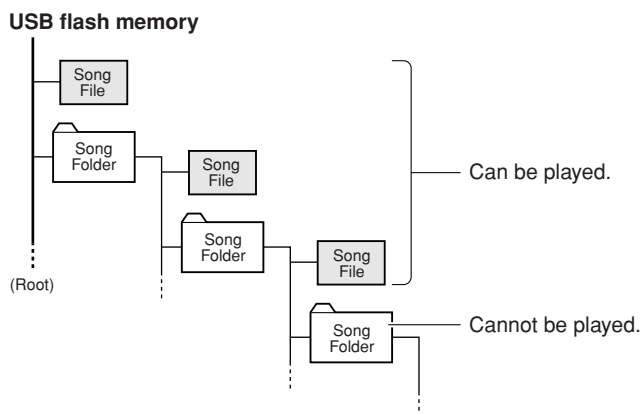

Specify the Song Track and Play the Song

When playing song data from a USB memory device, you can specify the song tracks in this setting. The "ALL" setting plays back all 16 tracks, while "1+2" plays back tracks 1 and 2.

Since piano songs are generally recorded to tracks 1 and 2 exclusively, the "1+2" setting is best used with only the piano voice.

Default setting is "1+2."

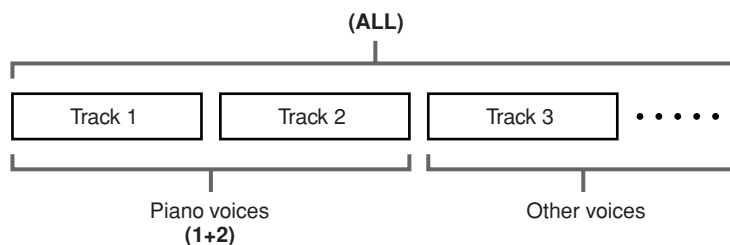

Specify the track to all tracks (ALL)

While holding down [BGM] and [VOICE] buttons simultaneously, press the B6 key.

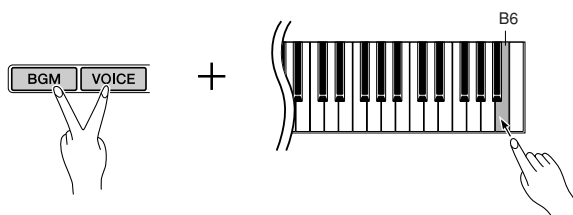

Specify the track to 1 and 2 tracks (1+2)

While holding down [BGM] and [VOICE] buttons simultaneously, press the C7 key.

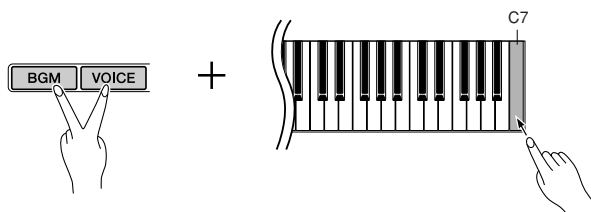

Keep in mind that songs recorded on other devices may use a variety of voices not available on this instrument and hence may sound different than the original songs. In general, this instrument should be used to play back piano songs.

Selecting & Playing Voices

Selecting Voices

1. While holding down the [VOICE] button, press one of the C1–A1 keys to select a voice.

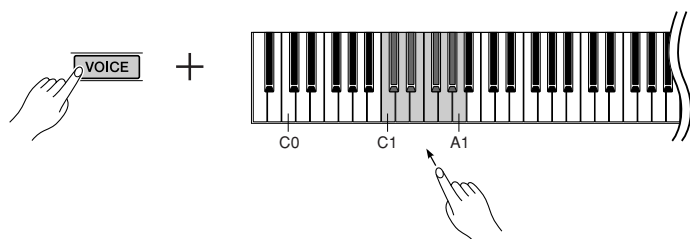

While holding down the [VOICE] button, use the **SELECT [-]/[+]** buttons to switch among the following ten voices. Pressing the [VOICE] button automatically calls up the first voice, Grand Piano 1.

Key	Voice Name	Description
C1	Grand Piano 1	Recorded samples from a full concert grand piano. Also includes three levels of dynamic sampling, sustain samples, and key-off samples for exceptionally realistic acoustic grand piano sound. Perfect for classical compositions as well as any other style that requires acoustic piano.
C#1	Grand Piano 2	Spacious and clear piano with bright reverb. Good for popular music.
D1	Piano & Strings	A Dual voice combining grand piano and strings – perfect for slow, orchestral piano music.
D#1	E. Piano 1	An electronic piano sound created by FM synthesis. Exceptional musical response with varying timbre according to keyboard dynamics. Good for standard popular music.
E1	E. Piano 2	The sound of an electric piano using hammer-struck metallic tines. Soft tone when played lightly, and an aggressive tone when played hard.
F1	Church Organ	This is a typical pipe organ sound (8 feet + 4 feet + 2 feet). Good for sacred music from the Baroque period.
F#1	Jazz Organ	The sound of a tonewheel type electric organ. Often heard in jazz and rock idioms.
G1	Strings	Stereo-sampled, large-scale strings ensemble with realistic reverb. Try combining this voice with piano in the DUAL.
G#1	Harpsichord	The definitive instrument for baroque music. Since harpsichord uses plucked strings, there is no touch response. There is, however, a characteristic additional sound when the keys are released.
A1	Vibraphone	Vibraphone played with relatively soft mallets. The tone becomes more metallic the harder you play.

TERMINOLOGY

Voice:

On the H01, the term “voice” means “instrument sound.”



When you select a voice, an appropriate reverb type will be selected automatically (page 18).

2. Adjust the volume.

Re-adjust the [MASTER VOLUME] slider for the most comfortable listening level during your performance.

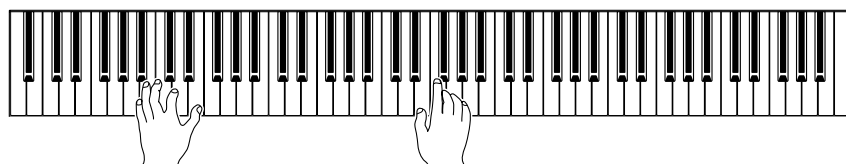
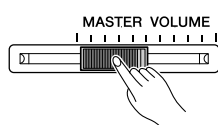

Using the Pedals

The H01 has three foot pedals: damper (right) pedal, sostenuto (center) pedal, and soft (left) pedal that produce a range of expressive effects similar to those produced by the pedals on an acoustic piano.

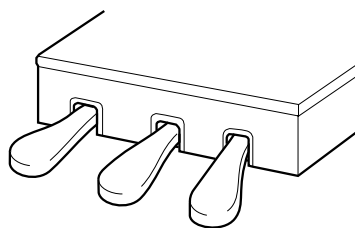

Damper (Right) Pedal

The damper pedal functions in the same way as a damper pedal on an acoustic piano. When the damper pedal is pressed, notes sustain longer. Releasing the pedal immediately stops (damps) any sustained notes.

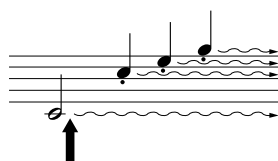

When you press the damper pedal here, the notes you play before you release the pedal sustain longer.



If the damper pedal doesn't work, make sure that the pedal cord is properly plugged into the main unit (page 24).

Sostenuto (Center) Pedal

If you play a note or chord on the keyboard and press the sostenuto pedal while the note(s) are held, those notes will sustain as long as you hold the pedal (as if the damper pedal had been pressed) but all subsequently played notes will not be sustained. This makes it possible to sustain a chord, for example, while other notes are played "staccato."

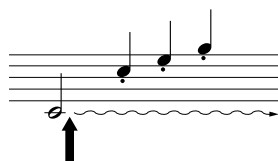

When you press the sostenuto pedal here while holding the note, the note will sustain as long as you hold the pedal.



Organ and string voices will continue to sound for as long as the sostenuto pedal is depressed.

Soft (Left) Pedal

The soft pedal reduces the volume and slightly changes the timbre of notes played while the pedal is pressed. The soft pedal will not affect notes that are already playing when it is pressed.

Combining Voices (Dual)

You can play voices simultaneously across the entire range of the keyboard. In this way, you can combine similar voices to create a thicker sound.

1. While holding down the [VOICE] button, press two keys in the range of C1 through A1 simultaneously (or press one key while holding another) to engage Dual.

Refer to “Selecting Voices” on page 15 for more information on the voices that are assigned to the keys.

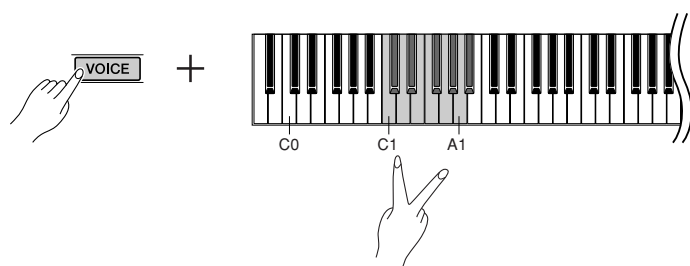

The voice assigned to the lower key will be designated as Voice 1, and the voice assigned to the higher key will be designated as Voice 2.

You can make the following settings for Voices 1 and 2 in Dual:

Setting the Octave

You can shift the pitch up and down in octave steps for Voice 1 and Voice 2 independently. Depending on which voices you combine in Dual, the combination may sound better if one of the voices is shifted up or down an octave.

While holding down the [VOICE] button, press one of the C5–F5 keys.

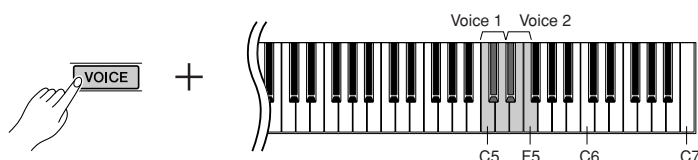

Voice 1	C5	-1	Voice 2	D#5	-1
	C#5	0		E5	0
	D5	+1		F5	+1

Setting the Balance

You can adjust the volume balance between two voices. For example, you can set one voice as the main voice with a louder setting, and make the other voice softer.

While holding down the [VOICE] button, press one of the F#5–F#6 keys.

A setting of “0” produces an equal balance between the two Dual voices. Settings below “0” increase the volume of Voice 2 in relation to Voice 1, and settings above “0” increase the volume of Voice 1 in relation to Voice 2.

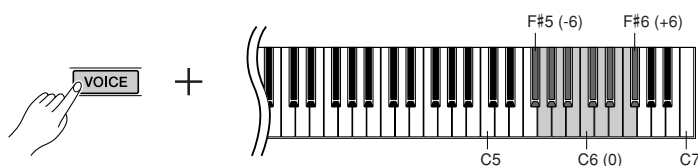

2. While holding down the [VOICE] button, press one of the C1–A1 keys (or press the [VOICE] button) to exit Dual and return to the normal single-voice play.



Reverb in Dual

The reverb type assigned to Voice 1 will take priority. If the reverb assigned to Voice 1 is set to OFF, the reverb assigned to Voice 2 will be in effect.

Adding Variations to the Sound – Reverb

This control enables you to select four different types of reverb effect that add extra depth and expression to the sound to create a realistic acoustic ambience.

Key	Reverb Type	Description
C2	Room	This setting adds a continuous reverb effect to the sound, similar to the acoustic reverberation you would hear in a room.
C#2	Hall1	For a "bigger" reverb sound, use the HALL 1 setting. This effect simulates the natural reverberation of a small-size concert hall.
D2	Hall2	For a truly spacious reverb sound, use the HALL 2 setting. This effect simulates the natural reverberation of a large concert hall.
D#2	Stage	Simulates the reverb of a stage environment.
E2	Off	No effect is applied.

Selecting a Reverb Type

While holding down the [VOICE] button, press one of the C2–E2 keys to select a reverb type.

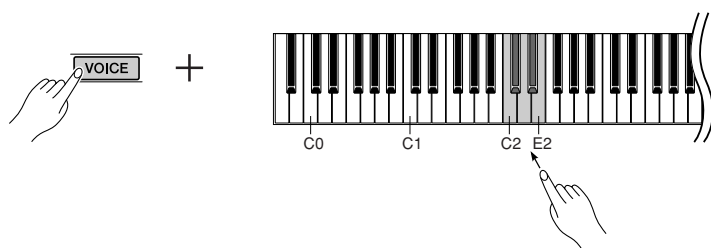

Adjusting Reverb Depth

While holding down the [VOICE] button, press one of the C3–G#4 keys to adjust the reverb depth for the selected voice.

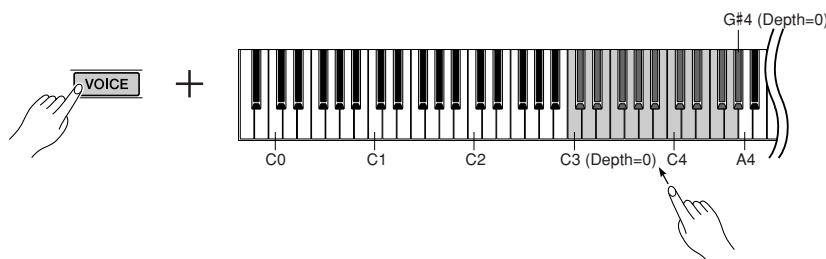

The depth value increases as you press higher keys.

While holding down the [VOICE] button, press the A4 key to set the reverb to the depth most suitable for the selected voice.



Reverb depth range:
0 (no effect)–
20 (maximum depth)



The default reverb type (including OFF) and depth settings are different for each voice.

Transposition

The Transpose function makes it possible to shift the pitch of the entire keyboard up or down in semitone intervals to facilitate playing in difficult key signatures, and to let you easily match the pitch of the keyboard to the range of a singer or other instruments. For example, if you set the transposition amount to “+5,” playing key C produces pitch F. In this way, you can play a song as though it were in C major, and the H01 will transpose it to the key of F.

Setting the amount of transposition

While holding down the [BGM] and [VOICE] buttons, press one of the F#2–F#3 keys to set the desired amount of transposition.

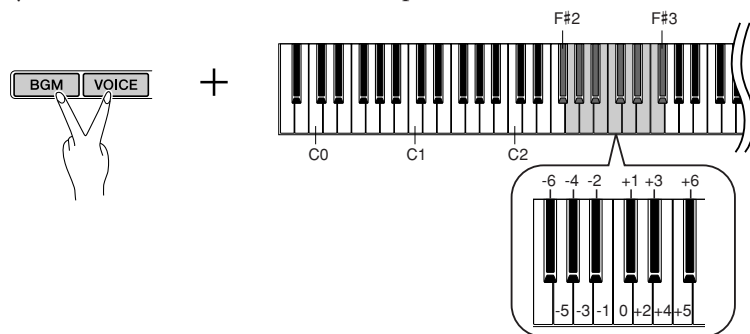

To transpose the pitch down (in semitone steps)

While holding down the [BGM] and [VOICE] buttons, press any key between F#2 and B2.

To transpose the pitch up (in semitone steps)

While holding down the [BGM] and [VOICE] buttons, press any key between C#3 and F#3.

To restore the normal pitch

While holding down the [BGM] and [VOICE] buttons, press the C3 key.

TERMINOLOGY

Transpose:

Changing the key signature. On the H01, transposing shifts the pitch of the entire keyboard.



Transposition range:

- F#2 (-6 semitones)–
- C3 (normal pitch)–
- F#3 (+6 semitones)

Fine tuning of the Pitch

You can fine tune the pitch of the entire instrument. This function is useful when you play the instrument along with other instruments or CD music.

Setting the Pitch

To raise the pitch in about 1cent steps (100 cents = 1 semitone):

Hold down the A-1 and B-1 keys simultaneously and press any key between C3 and B3.

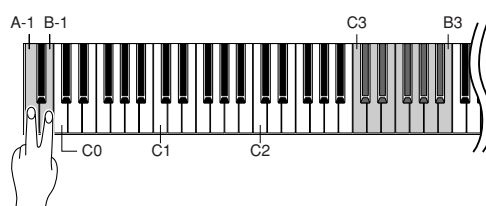

To lower the pitch in about 1cent steps (100 cents = 1 semitone):

Hold down the A-1 and A#-1 keys simultaneously and press any key between C3 and B3.

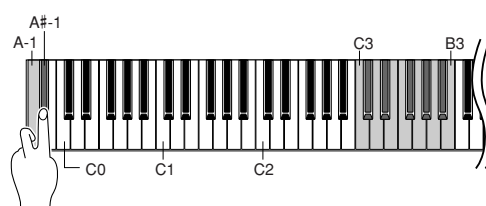

To restore standard pitch:

Hold down the A-1, A#-1 and B-1 simultaneously and press any key between C3 and B3.

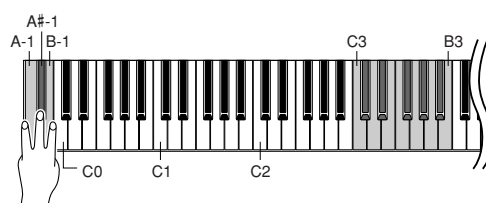

Setting range: -65+65 cents

The default setting (0 cent) is A3=440Hz. In the 440Hz region, 1Hz=approximately 4 cents. Pressing the key 8 times for example, will set A3 at approximately 442Hz.

TERMINOLOGY

Default setting:

The “Default setting” refers to the factory setting obtained when you first turn on the power to the instrument.

Touch Sensitivity

You can adjust the volume level that changes depending on how fast or strong you hit the keys. The following four settings are available.

Key	Touch Sensitivity	Description
A6	FIXED	The volume level does not change at all regardless of whether you play the keyboard soft or hard.
A#6	SOFT	The volume level does not change much when you play the keyboard soft or hard.
B6	MEDIUM	This is the standard piano touch response (default setting).
C7	HARD	The volume level changes very widely from pianissimo to fortissimo to facilitate dynamic and dramatic expression. You have to hit the keys hard to produce a loud sound.

Setting the Touch Sensitivity Type

While holding down the [VOICE] button, press one of the A6–C7 keys to select the desired touch sensitivity.

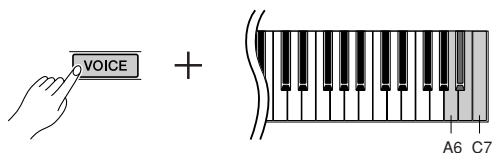

The touch sensitivity settings may have little or no effect with Church Organ and Harpsichord voices that are not normally responsive to keyboard dynamics.

Default setting:

B6 (Medium)

Troubleshooting

Problem	Possible Cause and Solution
The H01 does not turn on.	The H01 has not been plugged in properly. Securely insert the female plug into the socket on the H01, and the male plug into a proper AC outlet (page 10).
A click or pop is heard when the power is turned on or off.	This is normal when electrical current is being applied to the instrument.
Noise is heard from the speakers or headphones.	The noise may be due to interference caused by the use of a mobile phone in close proximity to the H01. Turn off the mobile phone, or use it further away from the H01.
The overall volume is low, or no sound is heard.	<ul style="list-style-type: none"> • The Master Volume is set too low; set it to an appropriate level using the [MASTER VOLUME] control. • Make sure a pair of headphones is not connected to the headphones jack (page 10).
The 50 Piano Preset songs cannot be played.	Make sure that a USB storage device is not connected to the [USB TO DEVICE] terminal.
The sustain pedal has no effect.	The pedal cable/plug may not be properly connected. Make sure to securely insert the pedal plug into the proper jack (page 24).
There is a slight difference in sound quality among different notes played on the keyboard.	This is normal and is a result of the sampling system.

Keyboard Stand Assembly

⚠ CAUTION

- Be careful not to confuse parts, and be sure to install all parts in the correct direction. Please assemble the unit in the appropriate sequence.
- Assembly should be carried out by at least two persons.
- Be sure to use the included screws only, and insert screws of the correct size in the correct hole locations. Do not use any other screws. Use of incorrect screws can cause damage or malfunction of the product.
- Be sure to tighten all screws upon completing assembly of each unit.
- To disassemble, reverse the assembly sequence.

Have a Phillips-head (+) screwdriver ready.

Remove all parts from the box. Confirm that all parts shown in the illustration are provided.

⚠ CAUTION

Be careful not to pinch your fingers when setting the instrument on the floor.

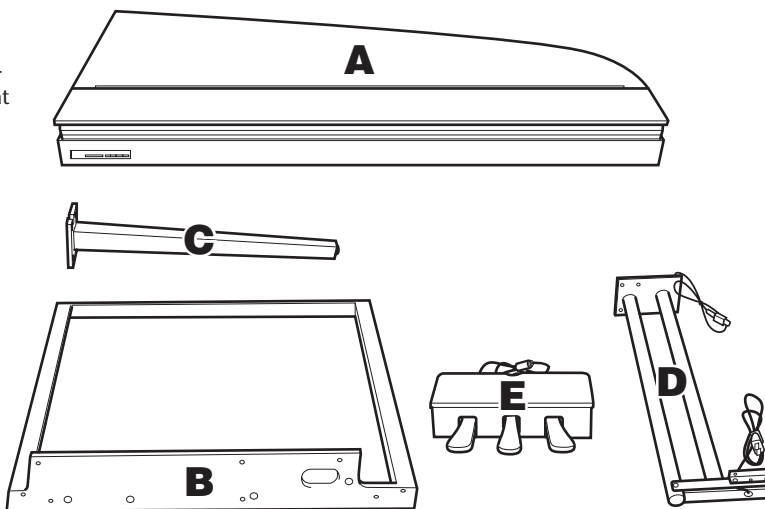

6 x 30 mm long screws x 4



6 x 20 mm short screws x 10



4 x 6 mm small screws x 6

Before starting installation, remove the vinyl ties that bundle the pedal cord and AC power cord.

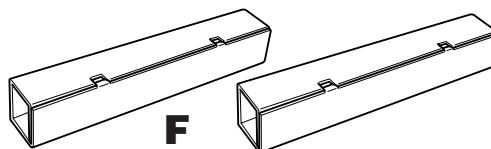

Remove two rectangle pads (800 x 130 mm) from the packing box.

1. Place A on top of the pads.

1-1 Locate two pads (F) so that they will be positioned about 30 cm inside from the left and right edges of A.

1-2 Place A on top of the pads.

⚠ CAUTION

Do not position the pad under the control panel.

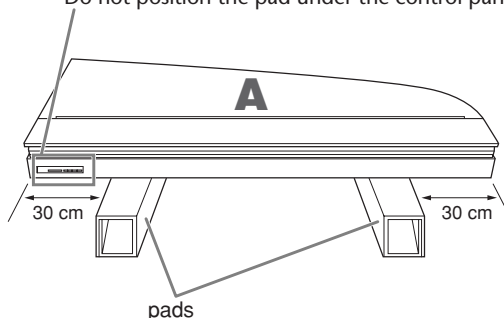

2. Raise A to the vertical position.

2-1 Raise A to the vertical position, with the keyboard side on the bottom, and hold A securely.

⚠ CAUTION

Do not release A until you finish Step 4.

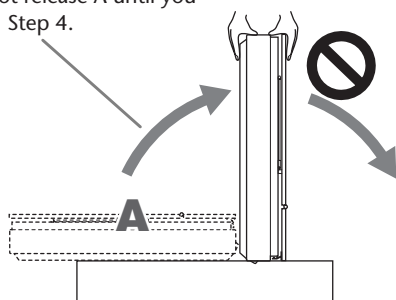

⚠ CAUTION

Do not tip A further than 90 degrees to avoid stress to the key cover and lid.

3. Attach B.

3-1 Align the holes on A with those on B and hold A and B together.

3-2 Finger-tighten six short screws (6x20 mm) starting with the top hole.

3-3 Tighten the screws securely.

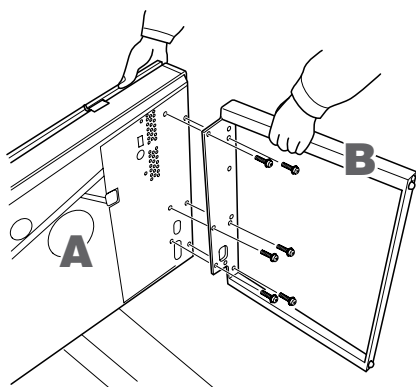

4. Attach C.

4-1 Hold C so that the notch on the bracket will face toward left, then align the holes on A with those on C.

4-2 Finger-tighten four short screws (6x20 mm) starting with the top hole.

4-3 Tighten the screws securely.

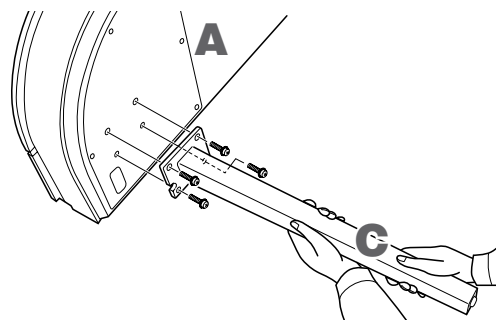

5. Assemble the pedal structure.

5-1 Pass the pedal cord (that comes out from the rear of pedal box E) through a hole on the bracket of D, then pass it through the pipe.

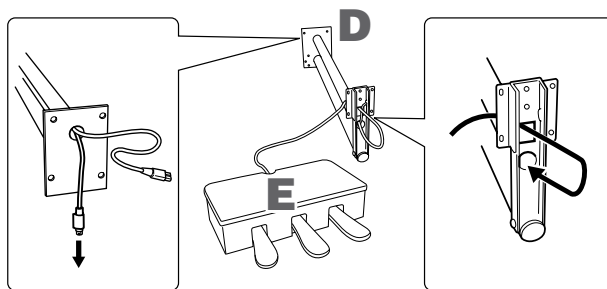

5-2 Align the holes on the bottom of E with the holes on the bracket of D, then attach E and D by tightening six small screws (4x6 mm). At this time, first tighten the two center screws, then tighten the rest of the screws.

5-3 Pull the end of the pedal cord to eliminate any slack inside the bracket on D.

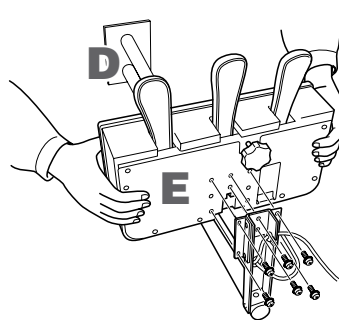

⚠ CAUTION

Hold E securely to avoid slippage.

6. Install the pedal structure.

6-1 Remove the covers from the grooves on the bottom surface of A.

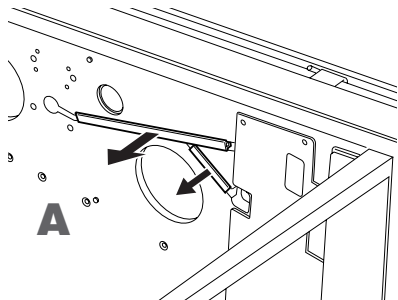

6-2 Align the pedal power cords (that come out from the pipes of D) along with the grooves on the bottom surface of A.

6-3 Align the holes on the bracket of D with the holes on A, then attach D to A by tightening four long screws (6x30 mm).

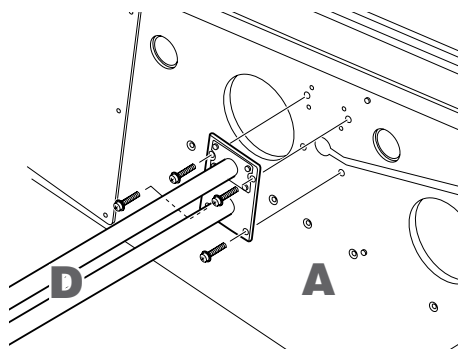

⚠ CAUTION

Be careful not to pinch the cords between the bracket and the surface of A.

7. Connect the cords.

7-1 Connect the pedal cord plug to the pedal connector in the correct orientation.

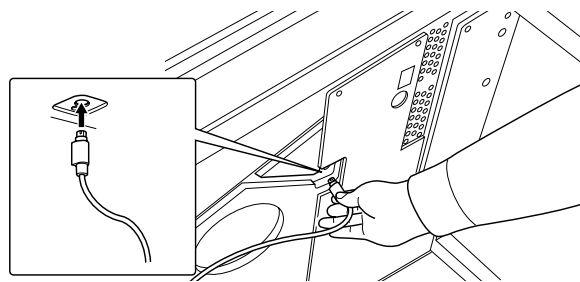

7-2 Connect the power cord plug to the power connector in the correct orientation.

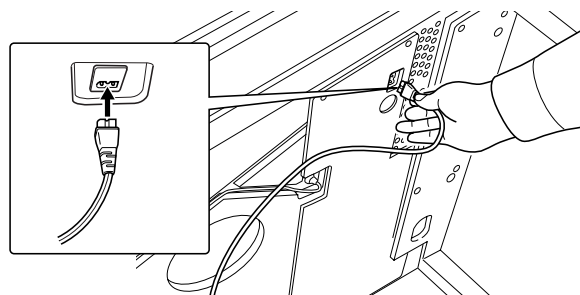

8. Replace the groove covers.

8-1 Insert the pedal cord and power cords into the grooves securely, then attach the groove covers.

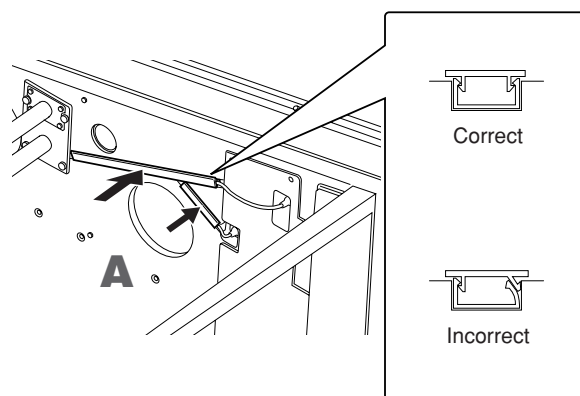

9. Raise A.

- 9-1** Securely hold the front side of A (the side currently facing toward the floor), then raise A.

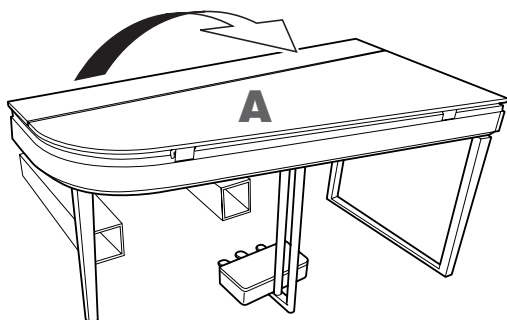

⚠ CAUTION

- Do not hold the control panel area.
- Be careful not to drop the instrument on your foot.

10. Rotate the adjuster.

- 10-1** Rotate the pedal height adjuster until the bottom of the pedal reaches the floor.

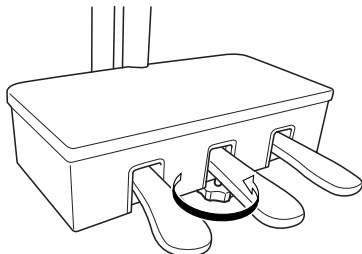

After completing the assembly, please check the following.

- Are there any parts left over?
 - Review the assembly procedure and correct any errors.
- Is the instrument clear of doors and other movable fixtures?
 - Move the instrument to an appropriate location.
- Does the instrument make a rattling noise when you shake it?
 - Tighten all screws.
- Does the pedal box rattle or give way when you step on the pedals?
 - Turn the adjuster so that it is set firmly against the floor.
- Are the pedal and power cords inserted securely into the sockets?
 - Check the connection.

⚠ CAUTION

If the main unit creaks or is otherwise unsteady when you play on the keyboard, refer to the assembly diagrams and retighten all screws.

⚠ CAUTION

When you relocate the unit after assembling it, be sure to hold the bottom of the main unit. In particular, hold the left side of the main unit along with the bottom of the upper frame of the left leg.

⚠ CAUTION

Do not hold the key cover or lid.

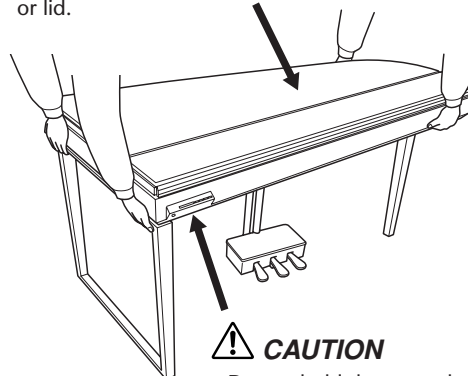

⚠ CAUTION

- Do not hold the control panel area.
- Be careful not to drop the instrument on your foot.

Song List / Song-Liste / Liste des morceaux / Lista de canciones

Song No.	Note	Scene No. Note Scene Title Song Name (Composer)	1	2	3	4	5	6	7	8	9	10	11	12	13
			C0	C#0	D0	D#0	E0	F0	F#0	G0	G#0	A0	A#0	B0	C1
			Home Party	Morning	Upbeat	Elegant	Relaxing	Nighttime	Melancholy	Mood Music	Fantasy	Baroque and Pre-romantic Music	Pre-romantic (Chopin)	Post-romantic	Modern French
1	C2	Sonate, K.380, L.23 (D. Scarlatti)		✓								✓			
2	C#2	Aria, Goldberg-Variationen, BWV.988 (J.S. Bach)					✓	✓				✓			
3	D2	The harmonious blacksmith (G.F. Händel)			✓							✓			
4	D#2	Sonate für Klavier Nr.5, K.283 (W.A. Mozart)		✓	✓							✓			
5	E2	Sonate für Klavier Nr.12, K.332 (W.A. Mozart)	✓	✓	✓							✓			
6	F2	Sonate für Klavier Nr.8 "Pathétique", op.13 (L.v. Beethoven)	✓				✓		✓			✓			
7	F#2	Sonate für Klavier Nr.14 "Mondschein", op.27-2 (L.v. Beethoven)	✓						✓			✓			
8	G2	Frühlingslied, op.62-6 (F. Mendelssohn)	✓			✓						✓			
9	G#2	Prélude, op.28-7 (F.F. Chopin)					✓	✓					✓		
10	A2	Prélude "Raindrop", op.28-15 (F.F. Chopin)	✓						✓	✓			✓		
11	A#2	Etude "Chanson de l'adieu", op.10-3 (F.F. Chopin)	✓						✓	✓			✓		
12	B2	Etude "Aeolian Harp", op.25-1 (F.F. Chopin)	✓		✓					✓			✓		
13	C3	Valse, op.64-2 (F.F. Chopin)							✓				✓		
14	C#3	Valse "L'adieu", op.69-1 (F.F. Chopin)					✓		✓				✓		
15	D3	Valse, op.69-2 (F.F. Chopin)							✓				✓		
16	D#3	Nocturne, op.9-1 (F.F. Chopin)							✓	✓			✓		
17	E3	Nocturne, op.9-2 (F.F. Chopin)	✓			✓	✓			✓			✓		
18	F3	Nocturne, op.15-2 (F.F. Chopin)	✓							✓			✓		
19	F#3	Nocturne, op.27-2 (F.F. Chopin)							✓	✓			✓		
20	G3	Nocturne No.20 (F.F. Chopin)	✓						✓				✓		
21	G#3	Berceuse, op.57 (F.F. Chopin)					✓	✓					✓		
22	A3	Von fremden Ländern und Menschen, op.15-1 (R. Schumann)					✓				✓	✓			
23	A#3	Träumerei, op.15-7 (R. Schumann)	✓				✓	✓			✓	✓			
24	B3	Des Abends, Phantasiestücke, op.12-1 (R. Schumann)					✓	✓			✓	✓			
25	C4	Eintritt, Waldszenen, op.82-1 (R. Schumann)		✓	✓						✓	✓			
26	C#4	Consolation No.3 (F. Liszt)					✓			✓				✓	
27	D4	Melody in F, op.3-1 (A. Rubinstein)	✓			✓								✓	
28	D#4	Walzer, op.39-15 (J. Brahms)				✓					✓			✓	
29	E4	La poupée, Jeux d'enfants, op.22-3 (G. Bizet)					✓	✓			✓			✓	
30	F4	Humoresque, op.101-7 (A. Dvořák)	✓			✓					✓			✓	
31	F#4	Arietta, Lyriske småstykker I, op.12-1 (E.H. Grieg)	✓				✓	✓			✓			✓	
32	G4	Sommerfugl, Lyriske stykker III, op.43-1 (E.H. Grieg)			✓						✓			✓	
33	G#4	Notturmo, Lyriske stykker V, op.54-4 (E.H. Grieg)								✓				✓	
34	A4	Sommeraften, Lyriske stykker X, op.71-2 (E.H. Grieg)								✓	✓			✓	
35	A#4	Romance sans paroles, op.17-3 (G. Fauré)				✓									✓
36	B4	Berceuse, Dolly, op.56-1 (G. Fauré)						✓			✓				✓
37	C5	Salut d'amour, op.12 (E. Elgar)	✓	✓	✓	✓								✓	
38	C#5	To a wild rose, Woodland sketches, op.51-1 (E.A. MacDowell)					✓	✓			✓			✓	
39	D5	Tango, España, op.165-2 (I. Albéniz)	✓		✓	✓								✓	
40	D#5	La fille aux cheveux de lin (C.A. Debussy)	✓				✓	✓							✓
41	E5	Arabesque 1 (C.A. Debussy)	✓			✓									✓
42	F5	Clair de lune (C.A. Debussy)	✓				✓								✓
43	F#5	Rêverie (C.A. Debussy)					✓	✓							✓
44	G5	La plus que lente (C.A. Debussy)								✓					✓
45	G#5	En bateau, Petite suite (C.A. Debussy)			✓	✓									✓
46	A5	Gymnopédie No.1 (E. Satie)					✓	✓							✓
47	A#5	Je te veux (E. Satie)	✓		✓	✓									✓
48	B5	Pavane pour une infante défunte (M. Ravel)	✓				✓		✓						✓
49	C6	Menuet, Le tombeau de Couperin (M. Ravel)	✓				✓								✓
50	C#6	A la manière de Borodine (M. Ravel)				✓									✓

Specifications / Technische Daten / Caractéristiques techniques / Especificaciones

Keyboard	88 keys (A-1–C7), Natural Wood keyboard (real wood on white keys only)
Sound Source	AWM Dynamic Stereo Sampling
Polyphony (Max.)	64
Voice Selection	10
Effect	Reverb
Volume	Master Volume
Controls	Dual, Transpose, Touch (Hard/Medium/Soft/Fixed)
Pedal	Damper (with half-pedal), Sostenuto, Soft
Songs	50 preset Songs
Jacks/Connectors	PHONES × 2, USB TO DEVICE, AUX OUT
Main Amplifiers	40 W × 2
Speakers	Oval (13 cm × 6 cm) × 2, (16 cm + 2.5 cm) × 2
Dimensions (W × D × H) (Lid up)	1,461 mm × 750 mm × 761 mm [57-1/2" × 29-1/2" × 30"] (1,487 mm × 760 mm × 1200 mm [58-1/2" × 30" × 47-1/4"])
Weight	82 kg (180 lbs. 12 oz.)
Accessories	Owner's Manual, Quick Operation Guide, Bench (included or optional depending on local)

- * Specifications and descriptions in this owner's manual are for information purposes only. Yamaha Corp. reserves the right to change or modify products or specifications at any time without prior notice. Since specifications, equipment or options may not be the same in every locale, please check with your Yamaha dealer.
- * Die technischen Daten und Beschreibungen in dieser Bedienungsanleitung dienen nur der Information. Yamaha Corp. behält sich das Recht vor, Produkte oder deren technische Daten jederzeit ohne vorherige Ankündigung zu verändern oder zu modifizieren. Da die technischen Daten, das Gerät selbst oder Sonderzubehör nicht in jedem Land gleich sind, setzen Sie sich im Zweifel bitte mit Ihrem Yamaha-Händler in Verbindung.
- * Les caractéristiques techniques et les descriptions du mode d'emploi ne sont données que pour information. Yamaha Corp. se réserve le droit de changer ou modifier les produits et leurs caractéristiques techniques à tout moment sans aucun avis. Du fait que les caractéristiques techniques, les équipements et les options peuvent différer d'un pays à l'autre, adressez-vous au distributeur Yamaha le plus proche.
- * Las especificaciones y descripciones de este manual del propietario tienen sólo el propósito de servir como información. Yamaha Corp. se reserva el derecho a efectuar cambios o modificaciones en los productos o especificaciones en cualquier momento sin previo aviso. Puesto que las especificaciones, equipos u opciones pueden no ser las mismas en todos los mercados, solicite información a su distribuidor Yamaha.

Optional Equipment / Optionales Zubehör / Equipements en option / Equipo opcional

Music Rest / Notenablage / Pupitre / Atril (YMR-01)

FCC INFORMATION (U.S.A.)

1. **IMPORTANT NOTICE: DO NOT MODIFY THIS UNIT!**

This product, when installed as indicated in the instructions contained in this manual, meets FCC requirements. Modifications not expressly approved by Yamaha may void your authority, granted by the FCC, to use the product.

2. **IMPORTANT:** When connecting this product to accessories and/or another product use only high quality shielded cables. Cable/s supplied with this product **MUST** be used. Follow all installation instructions. Failure to follow instructions could void your FCC authorization to use this product in the USA.
3. **NOTE:** This product has been tested and found to comply with the requirements listed in FCC Regulations, Part 15 for Class "B" digital devices. Compliance with these requirements provides a reasonable level of assurance that your use of this product in a residential environment will not result in harmful interference with other electronic devices. This equipment generates/uses radio frequencies and, if not installed and used according to the instructions found in the users manual, may cause interference harmful to the operation of

other electronic devices. Compliance with FCC regulations does not guarantee that interference will not occur in all installations. If this product is found to be the source of interference, which can be determined by turning the unit "OFF" and "ON", please try to eliminate the problem by using one of the following measures:

Relocate either this product or the device that is being affected by the interference.

Utilize power outlets that are on different branch (circuit breaker or fuse) circuits or install AC line filter/s.

In the case of radio or TV interference, relocate/reorient the antenna. If the antenna lead-in is 300 ohm ribbon lead, change the lead-in to co-axial type cable.

If these corrective measures do not produce satisfactory results, please contact the local retailer authorized to distribute this type of product. If you can not locate the appropriate retailer, please contact Yamaha Corporation of America, Electronic Service Division, 6600 Orangethorpe Ave, Buena Park, CA90620

The above statements apply **ONLY** to those products distributed by Yamaha Corporation of America or its subsidiaries.

* This applies only to products distributed by YAMAHA CORPORATION OF AMERICA.

(class B)

IMPORTANT NOTICE FOR THE UNITED KINGDOM

Connecting the Plug and Cord

IMPORTANT. The wires in this mains lead are coloured in accordance with the following code:

BLUE : NEUTRAL
BROWN : LIVE

As the colours of the wires in the mains lead of this apparatus may not correspond with the coloured markings identifying the terminals in your plug proceed as follows:

The wire which is coloured BLUE must be connected to the terminal which is marked with the letter N or coloured BLACK.

The wire which is coloured BROWN must be connected to the terminal which is marked with the letter L or coloured RED.

Making sure that neither core is connected to the earth terminal of the three pin plug.

• This applies only to products distributed by Yamaha-Kemble Music (U.K.) Ltd. (2 wires)

CAUTION: TO PREVENT ELECTRIC SHOCK, MATCH WIDE BLADE OF PLUG TO WIDE SLOT, FULLY INSERT.

ATTENTION: POUR ÉVITER LES CHOCs ÉLECTRIQUES, INTRODUIRE LA LAME LA PLUS LARGE DE LA FICHE DANS LA BORNE CORRESPONDANTE DE LA PRISE ET POUSSER JUSQU'AU FOND.

• This applies only to products distributed by Yamaha Canada Music Ltd. (polarity)
• Ceci ne s'applique qu'aux produits distribués par Yamaha Canada Musique Ltée.

For details of products, please contact your nearest Yamaha representative or the authorized distributor listed below.

Pour plus de détails sur les produits, veuillez-vous adresser à Yamaha ou au distributeur le plus proche de vous figurant dans la liste suivante.

Die Einzelheiten zu Produkten sind bei Ihrer unten aufgeführten Niederlassung und bei Yamaha Vertragshändlern in den jeweiligen Bestimmungsländern erhältlich.

Para detalles sobre productos, contacte su tienda Yamaha más cercana o el distribuidor autorizado que se lista debajo.

NORTH AMERICA

CANADA

Yamaha Canada Music Ltd.
135 Milner Avenue, Scarborough, Ontario,
M1S 3R1, Canada
Tel: 416-298-1311

U.S.A.

Yamaha Corporation of America
6600 Orangethorpe Ave., Buena Park, Calif. 90620,
U.S.A.
Tel: 714-522-9011

CENTRAL & SOUTH AMERICA

MEXICO

Yamaha de México S.A. de C.V.
Calz. Javier Rojo Gómez #1149,
Col. Guadalupe del Moral
C.P. 09300, México, D.F., México
Tel: 55-5804-0600

BRAZIL

Yamaha Musical do Brasil Ltda.
Av. Reboucas 2636-Pinheiros CEP: 05402-400
Sao Paulo-SP, Brasil
Tel: 011-3085-1377

ARGENTINA

Yamaha Music Latin America, S.A.
Sucursal de Argentina
Viamonte 1145 Piso2-B 1053,
Buenos Aires, Argentina
Tel: 1-4371-7021

PANAMA AND OTHER LATIN AMERICAN COUNTRIES/ CARIBBEAN COUNTRIES

Yamaha Music Latin America, S.A.
Torre Banco General, Piso 7, Urbanización Marbella,
Calle 47 y Aquilino de la Guardia,
Ciudad de Panamá, Panamá
Tel: +507-269-5311

EUROPE

THE UNITED KINGDOM

Yamaha-Kemble Music (U.K.) Ltd.
Sherbourne Drive, Tilbrook, Milton Keynes,
MK7 8BL, England
Tel: 01908-366700

IRELAND

Danfay Ltd.
61D, Sallynoggin Road, Dun Laoghaire, Co. Dublin
Tel: 01-2859177

GERMANY

Yamaha Music Central Europe GmbH
Siemensstraße 22-34, 25462 Rellingen, Germany
Tel: 04101-3030

SWITZERLAND/LIECHTENSTEIN

**Yamaha Music Central Europe GmbH,
Branch Switzerland**
Seefeldstrasse 94, 8008 Zürich, Switzerland
Tel: 01-383 3990

AUSTRIA

**Yamaha Music Central Europe GmbH,
Branch Austria**
Schleiergasse 20, A-1100 Wien, Austria
Tel: 01-60203900

CZECH REPUBLIC/SLOVAKIA/ HUNGARY/SLOVENIA

**Yamaha Music Central Europe GmbH,
Branch Austria, CEE Department**
Schleiergasse 20, A-1100 Wien, Austria
Tel: 01-602039025

POLAND

**Yamaha Music Central Europe GmbH
Sp.z. o.o. Oddział w Polsce**
ul. 17 Stycznia 56, PL-02-146 Warszawa, Poland
Tel: 022-868-07-57

THE NETHERLANDS/ BELGIUM/LUXEMBOURG

**Yamaha Music Central Europe GmbH,
Branch Benelux**
Clarissenhof 5-b, 4133 AB Vianen, The Netherlands
Tel: 0347-358 040

FRANCE

Yamaha Musique France
BP 70-77312 Marne-la-Vallée Cedex 2, France
Tel: 01-64-61-4000

ITALY

Yamaha Musica Italia S.P.A.
Viale Italia 88, 20020 Lainate (Milano), Italy
Tel: 02-935-771

SPAIN/PORTUGAL

Yamaha-Hazen Música, S.A.
Ctra. de la Coruna km. 17, 200, 28230
Las Rozas (Madrid), Spain
Tel: 91-639-8888

GREECE

Philippos Nakas S.A. The Music House
147 Skiathou Street, 112-55 Athens, Greece
Tel: 01-228 2160

SWEDEN

Yamaha Scandinavia AB
J. A. Wettergrens Gata 1
Box 30053
S-400 43 Göteborg, Sweden
Tel: 031 89 34 00

DENMARK

YS Copenhagen Liaison Office
Generatorvej 6A
DK-2730 Herlev, Denmark
Tel: 44 92 49 00

FINLAND

F-Musiikki Oy
Kluuvikatu 6, P.O. Box 260,
SF-00101 Helsinki, Finland
Tel: 09 618511

NORWAY

Norsk filial av Yamaha Scandinavia AB
Grini Næringspark 1
N-1345 Østerås, Norway
Tel: 67 16 77 70

ICELAND

Skifan HF
Skeifan 17 P.O. Box 8120
IS-128 Reykjavik, Iceland
Tel: 525 5000

OTHER EUROPEAN COUNTRIES

Yamaha Music Central Europe GmbH
Siemensstraße 22-34, 25462 Rellingen, Germany
Tel: +49-4101-3030

AFRICA

**Yamaha Corporation,
Asia-Pacific Music Marketing Group**
Nakazawa-cho 10-1, Hamamatsu, Japan 430-8650
Tel: +81-53-460-2312

MIDDLE EAST

TURKEY/CYPRUS

Yamaha Music Central Europe GmbH
Siemensstraße 22-34, 25462 Rellingen, Germany
Tel: 04101-3030

OTHER COUNTRIES

Yamaha Music Gulf FZE
LB21-128 Jebel Ali Freezone
P.O.Box 17328, Dubai, U.A.E.
Tel: +971-4-881-5868

ASIA

THE PEOPLE'S REPUBLIC OF CHINA

Yamaha Music & Electronics (China) Co.,Ltd.
25/F., United Plaza, 1468 Nanjing Road (West),
Jingan, Shanghai, China
Tel: 021-6247-2211

HONG KONG

Tom Lee Music Co., Ltd.
11/F., Silvercord Tower 1, 30 Canton Road,
Tsimshatsui, Kowloon, Hong Kong
Tel: 2737-7688

INDONESIA

PT. Yamaha Music Indonesia (Distributor)
PT. Nusantik
Gedung Yamaha Music Center, Jalan Jend. Gatot
Subroto Kav. 4, Jakarta 12930, Indonesia
Tel: 21-520-2577

KOREA

Yamaha Music Korea Ltd.
Tong-Yang Securities Bldg. 16F 23-8 Yoido-dong,
Yongdungpo-ku, Seoul, Korea
Tel: 02-3770-0660

MALAYSIA

Yamaha Music Malaysia, Sdn., Bhd.
Lot 8, Jalan Perbandaran, 47301 Kelana Jaya,
Petaling Jaya, Selangor, Malaysia
Tel: 3-78030900

PHILIPPINES

Yupangco Music Corporation
339 Gil J. Puyat Avenue, P.O. Box 885 MCPO,
Makati, Metro Manila, Philippines
Tel: 819-7551

SINGAPORE

Yamaha Music Asia Pte., Ltd.
#03-11 A-Z Building
140 Paya Lebar Road, Singapore 409015
Tel: 747-4374

TAIWAN

Yamaha KHS Music Co., Ltd.
3F, #6, Sec.2, Nan Jing E. Rd. Taipei.
Taiwan 104, R.O.C.
Tel: 02-2511-8688

THAILAND

Siam Music Yamaha Co., Ltd.
891/1 Siam Motors Building, 15-16 floor
Rama 1 road, Wangmai, Pathumwan
Bangkok 10330, Thailand
Tel: 02-215-2626

OTHER ASIAN COUNTRIES

**Yamaha Corporation,
Asia-Pacific Music Marketing Group**
Nakazawa-cho 10-1, Hamamatsu, Japan 430-8650
Tel: +81-53-460-2317

OCEANIA

AUSTRALIA

Yamaha Music Australia Pty. Ltd.
Level 1, 99 Queensbridge Street, Southbank,
Victoria 3006, Australia
Tel: 3-9693-5111

NEW ZEALAND

Music Houses of N.Z. Ltd.
146/148 Captain Springs Road, Te Papapa,
Auckland, New Zealand
Tel: 9-634-0099

COUNTRIES AND TRUST TERRITORIES IN PACIFIC OCEAN

**Yamaha Corporation,
Asia-Pacific Music Marketing Group**
Nakazawa-cho 10-1, Hamamatsu, Japan 430-8650
Tel: +81-53-460-2312

HEAD OFFICE Yamaha Corporation, Pro Audio & Digital Musical Instrument Division
Nakazawa-cho 10-1, Hamamatsu, Japan 430-8650
Tel: +81-53-460-3273



Clavinova Web site
<http://music.yamaha.com/homekeyboard>
Yamaha Manual Library
<http://www.yamaha.co.jp/manual/>

U.R.G., Pro Audio & Digital Musical Instrument Division, Yamaha Corporation
© 2006 Yamaha Corporation

WG91890 004POAP?.-??CO
Printed in Vietnam

Free Manuals Download Website

<http://myh66.com>

<http://usermanuals.us>

<http://www.somanuals.com>

<http://www.4manuals.cc>

<http://www.manual-lib.com>

<http://www.404manual.com>

<http://www.luxmanual.com>

<http://aubethermostatmanual.com>

Golf course search by state

<http://golfingnear.com>

Email search by domain

<http://emailbydomain.com>

Auto manuals search

<http://auto.somanuals.com>

TV manuals search

<http://tv.somanuals.com>