

ELECTRIC GUITAR

Pacifica120S

SERVICE MANUAL

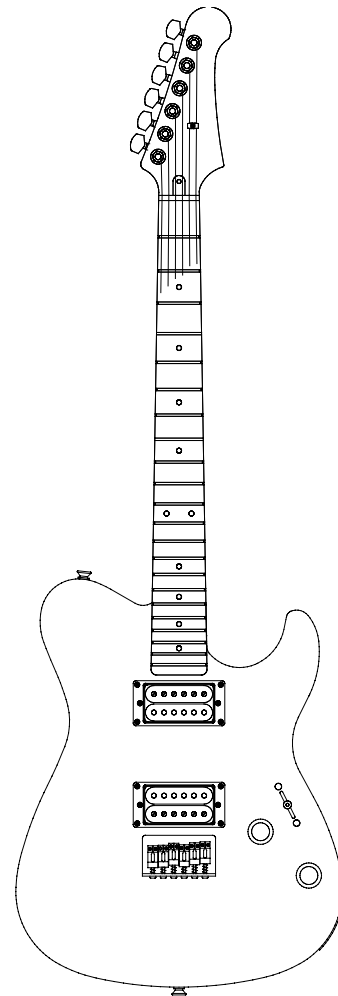

■ CONTENTS

OVERALL ASSEMBLY	2
CIRCUIT DIAGRAM	4
WIRING	4
SPECIFICATIONS	4

OVERALL ASSEMBLY

E27 Bridge Assembly YP-09B : Chrome (QC168700)

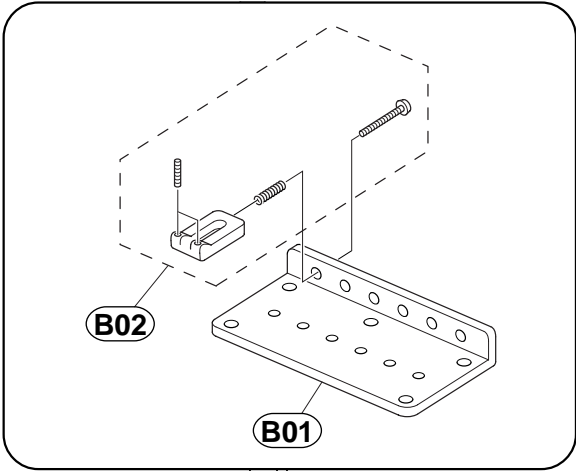

A01b
A seal is attached on the rear of the neck.
PAC120S

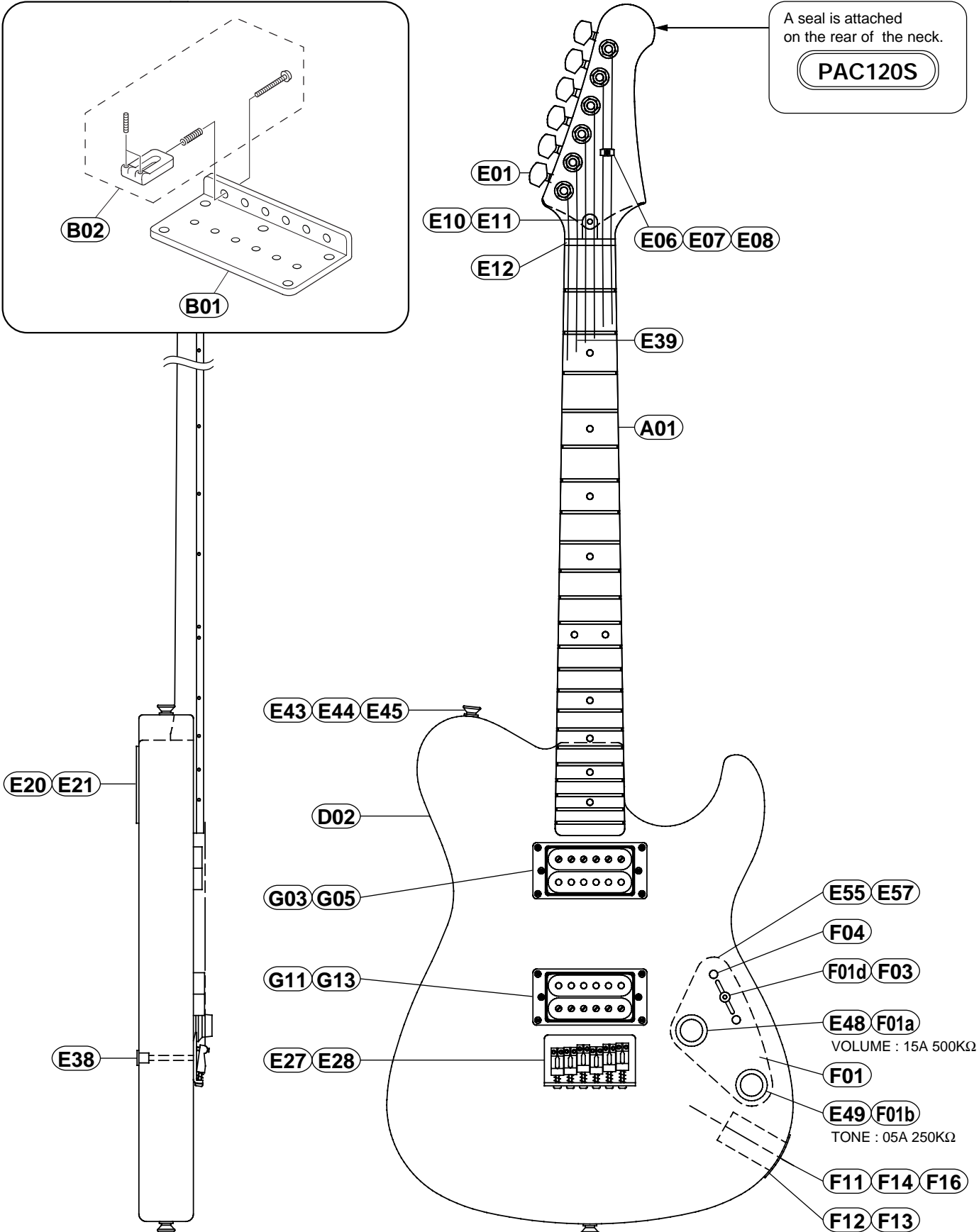

REF NO.	PART NO.	DESCRIPTION		REMARKS	QTY	RANK
* A01	DX809500	OVERALL ASSEMBLY		Pacifica120S		
	AA809390	Neck Assembly				01
	AA805410	Square Washer				03
A01b	--	Adjusting Nut		(QC45700)		
	--	Seal				
D02	--	Body				
E01	QC164900	Tuning Machine Assembly	RM1273 (CR)	1set		12
E06	AA819700	String Guide				02
E07	QC370200	Spacer	BL			02
E08	EQ221106	Round Head Wood Screw	2.1×10 FCM33G	(0370401)		01
E10	VD955900	Rod Cover	BL			01
E11	EB620070	Oval Head Wood Screw	2.1×13 FCM3BL			
E12	VB344800	Nut	41mm (BL)			04
E20	QC015100	Neck Plate	CR			04
E21	EN240060	Oval Head Tapping Screw	4.0×45 FNM33G		4	01
E27	QC168700	Bridge Assembly	YP-09B (CR)			13
E28	EB630100	Oval Head Wood Screw	3.5×25 FCM33G		5	02
E38	QC329900	Bushing	CR		6	
E39	--	Strings	XL-120	1set (QC16510)		
E43	BB801510	Strap Button	ST type (CR)		2	04
E44	EN230140	Oval Head Tapping Screw	3.0×25 FNM33G		2	04
E45	VB793700	Spacer	BL		2	01
E48	QC016200	Volume Knob	BL ST type			02
E49	QC016300	Tone Knob	BL ST type			02
E55	QC019200	Back Cover	Electrical (BL)			05
E57	EB620020	Oval Head Wood Screw	2.7×13 FCM3BL		3	03
F01	--	Electrical Unit		(QC16400)		
F01a	HS120070	Variable Resistor	15A 500K ohm	VOLUME		03
F01b	HS120100	Variable Resistor	05A 250K ohm	TONE		03
F01c	FA114220	Mylar Cap.	0.022uF 50 K			02
F01d	QA097800	Pickup Switch	3-P			05
F03	CB821810	Knob	BL			02
F04	EF230086	Oval Head Screw	3.0×8 FCM33G	(0375508)	2	01
F11	QC234800	Electrical Unit (Jack Assy)				06
F12	VB518300	Jack Panel	BL			05
F13	EB620020	Oval Head Wood Screw	2.7×13 FCM3BL		2	03
F14	LX200020	Hexagonal Nut	9S FCM33G			01
F16	ET800180	Toothed Lock Washer	A9S FNM33G			01
* G03	QC457300	Pickup Assembly		Front		
* G05	20454100	Pan Head Wood Screw	2.4×16 FCM3BL		4	
G11	QC371100	Pickup Assembly		Rear		10
* G13	20454100	Pan Head Wood Screw	2.4×16 FCM3BL		4	
H01	QC240300	Accessory Unit	(I)	1set		08
	QC168700	Bridge Assembly	YP-09B (CR)			13
B01	AX816970	Bridge Base	CR			03
B02	AX816980	Bridge Piece Assembly	CR		6	

* : New Parts

RANK : Japan only

WARNING : CHEMICAL CONTENT NOTICE!

The solder used in the production of this product contains LEAD. In addition, other electrical/electronic and/or plastic (Where applicable) components may also contain traces of chemicals found by the California Health and Welfare Agency (and possibly other entities) to cause cancer and/or birth defects or other reproductive harm.

DO NOT PLACE SOLDER, ELECTRICAL/ELECTRONIC OR PLASTIC COMPONENTS IN YOUR MOUTH FOR ANY REASON WHAT SO EVER!

Avoid prolonged, unprotected contact between solder and your skin! When soldering, do not inhale solder fumes or expose eyes to solder/flux vapor!

If you come in contact with solder or components located inside the enclosure of this product, wash your hands before handling food.

■ CIRCUIT DIAGRAM

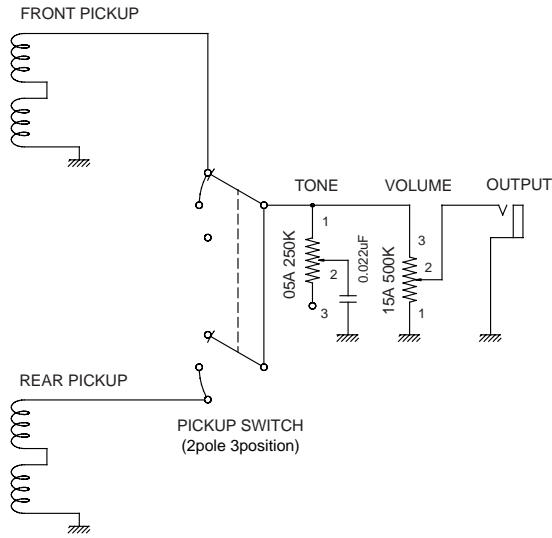

■ WIRING

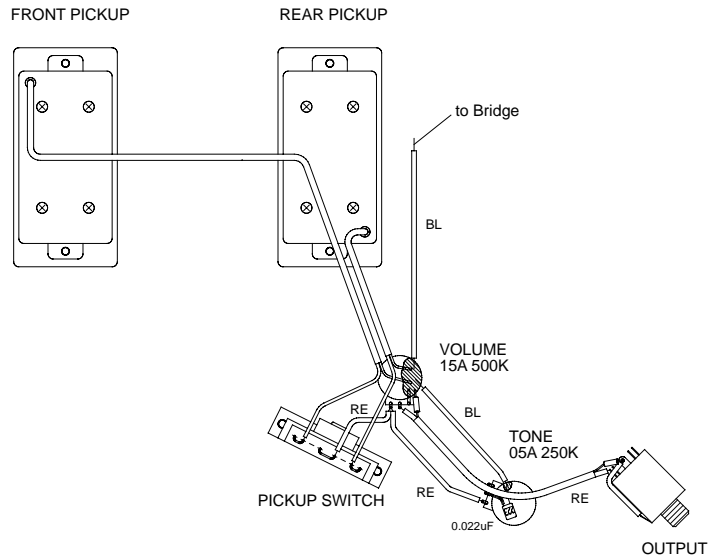

■ SPECIFICATIONS

● STANDARD SPECIFICATIONS

Scale Length 648mm
 Body-Neck Construction Bolt On
 Length 984.5mm
 Width 328mm
 Net Weight 3.4kg

● COLOR

Body
 YNS Yellow Natural Satin
 BL Black
 VW Vintage White
 Neck
 NT Natural

● BODY

Material Alder
 Body Depth 44mm

● FINGERBOARD

Material Rose
 Fingerboard Width 0-F 41.0 mm, 12-F 51.4 mm
 No. of Frets 22

● NECK

Material Maple
 Neck Thickness 1-F 20.9 mm, 12-F 22.9 mm

● PARTS

Hardware Chrome Plated
 Nut Urea
 Bridge YP-09B : Chrome
 Strings XL-120

● CONTROLS

Volume 15A 500k ohm × 1
 Tone 05A 250k ohm × 1
 Pickup SW 3P Lever Switch × 1

● PICKUPS

Front/Rear Open Humbucking
 Magnet
 Front/Rear Ferrite

Free Manuals Download Website

<http://myh66.com>

<http://usermanuals.us>

<http://www.somanuals.com>

<http://www.4manuals.cc>

<http://www.manual-lib.com>

<http://www.404manual.com>

<http://www.luxmanual.com>

<http://aubethermostatmanual.com>

Golf course search by state

<http://golfingnear.com>

Email search by domain

<http://emailbydomain.com>

Auto manuals search

<http://auto.somanuals.com>

TV manuals search

<http://tv.somanuals.com>