

ELECTRIC GUITAR AEX500N-2

SERVICE MANUAL



AEX500N-2 (NT)

■ CONTENTS

OVERALL ASSEMBLY	2
AMPLIFIER ASSEMBLY	4
ELECTRICAL PARTS	5
CIRCUIT BOARD	6
CIRCUIT DIAGRAM	7
WIRING	8
SPECIFICATIONS	8

OVERALL ASSEMBLY

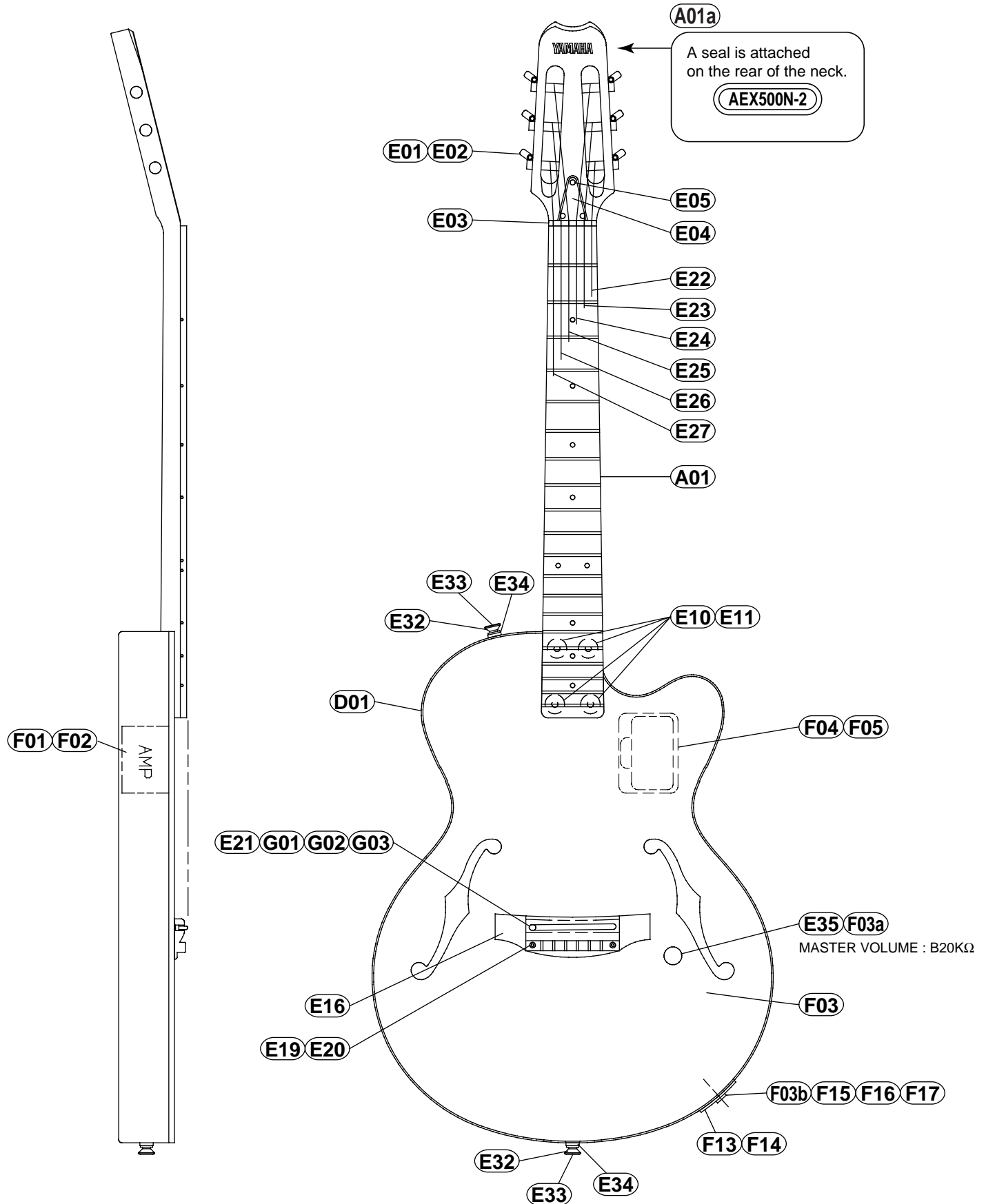

REF NO.	PART NO.	DESCRIPTION		REMARKS	QTY	RANK
		OVERALL ASSEMBLY		AEX500N-2		
* A01	AAX43790	Neck Assembly				
A01a	--	Seal		(QC59600)		
D01	--	Body				
E01	QA170300	Tuning Machine Assembly	RM1258 (Gold)	1set		
E02	03714060	Round Head Wood Screw	2.1X8 (Brown)		8	01
E03	VQ014700	Nut	Urea 43mm (Ivory)			02
E04	VQ011800	Rod Cover	Black			02
E05	03706220	Oval Head Wood Screw	2.1X10 (Black)		3	01
E10	QC205200	Neck Joint Bushing	Black		4	04
E11	EN240070	Oval Head Tapping Screw	4.0X45 (Black)		4	
* E16	QC745500	Bridge				
E19	20454100	Oval Head Wood Screw	2.4X16 (Chrome)		2	01
E20	03377460	Cap	M5.0 (White)		2	01
E21	QA079400	Bridge Saddle	Urea 75X3X9.5	Ivory		02
E22	--	String	CG S11	1 (QA33300)		
E23	--	String	CG S12	2 (QA33310)		
E24	--	String	CG S13	3 (QA33320)		
E25	--	String	CG S14	4 (QA25310)		
E26	--	String	CG S15	5 (QA25320)		
E27	--	String	CG S16	6 (QA25330)		
E32	BB802460	End Pin	ST-type (Gold)		2	02
E33	EN230130	Oval Head Wood Screw	3.0X25 (Gold)		2	
E34	VB793700	Spacer Felt	Black		2	01
E35	QC466500	Wood Knob Assembly	M19 H=17.5	MASTER VOLUME		04
* F01	QC741500	Pre-amplifier Assembly				
F02	EB620020	Oval Head Wood Screw	2.7X13 (Black)		2	03
F03	--	Electrical Unit (Jack&Vol)		(QC39950)		
F03a	QC259500	Variable Resistor	B20K ohm	MASTER VOLUME		04
F03b	LB201120	Jack		with Battery Cord		03
F04	QC399100	Box for Dry Cell				04
F05	QC025000	Pan Head Tapping Screw	3.0X8 (Black)		2	
F13	VB518300	Jack Panel				05
F14	EB620020	Oval Head Wood Screw	2.7X13 (Black)		2	03
F15	LX200020	Hexagonal Nut	9S (Chrome)			01
F16	LX200010	Flat Washer	9S (Chrome)			01
F17	ET800180	Toothed Lock Washer	9S		3	01
* G01	QC741400	Piezo Pickup Assembly	Monaural (HP-637)			
G02	LB009020	Connector Housing	X2P-XHP 2P	for Pickup		01
G03	VC921600	Pickup Case PU-G	PU-G FG			07
H01	QC354400	Accessory Unit	G-5	1set		08
	QA262600	Cord	D			05
	AA805430	Wrench	#5			04
H02	--	Battery	9V Dry cell	(PC10008)		

*: New Parts

RANK: Japan only

AMPLIFIER ASSEMBLY

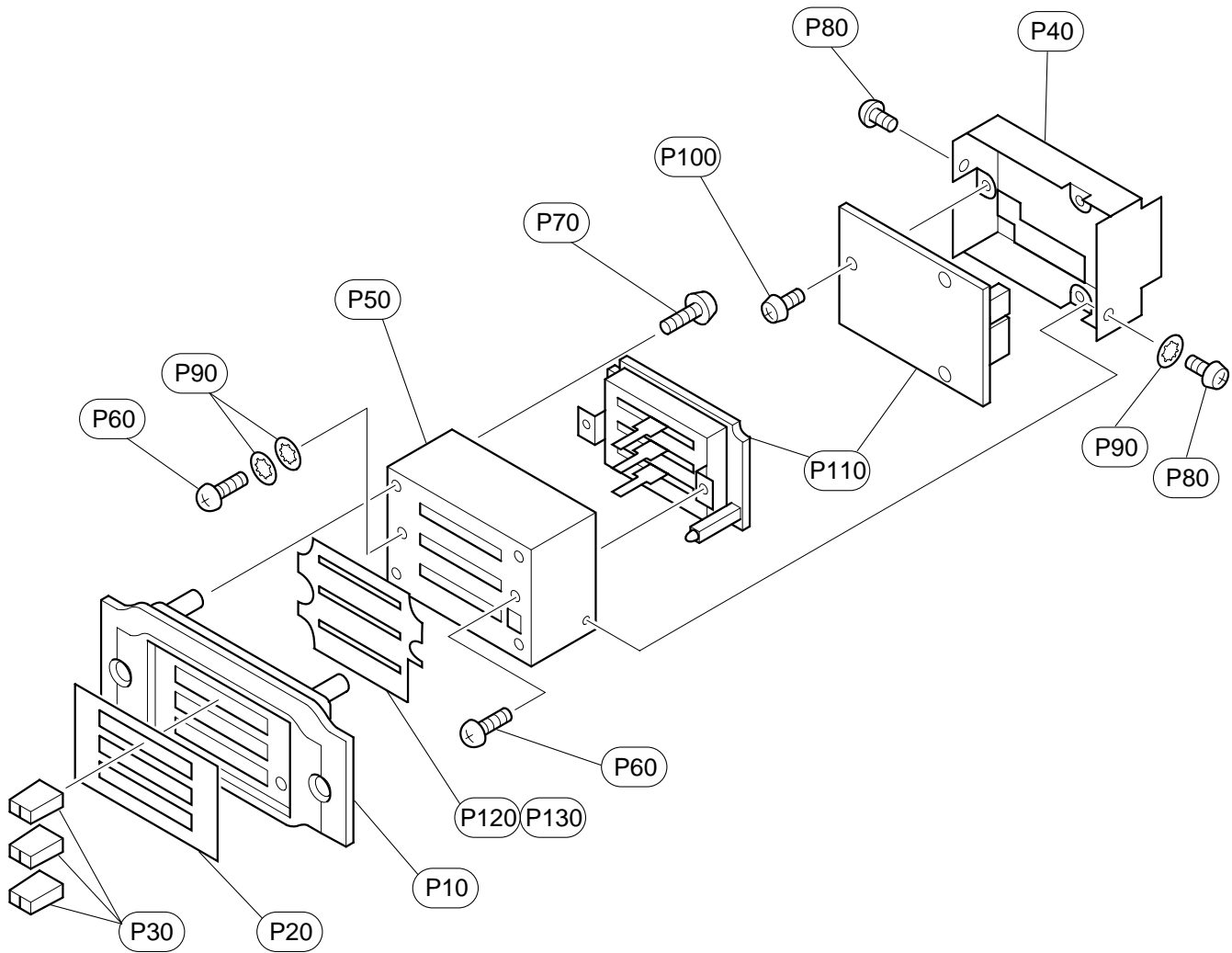

REF NO.	PART NO.	DESCRIPTION		REMARKS	QTY	RANK
*	QC741500	Pre-amplifier Assembly		AEX500N-2		
P10	QC398300	Escutcheon, Amplifier	AEX-J2			02
P20	QC398400	Panel	AEX-J2			03
P30	QC200500	Slide Knob		LOW/MID/HIGH	3	08
P40	QC398500	Case L	LOWER			03
P50	QC398600	Case U	UPPER			02
P60	VT805400	Truss Head Screw	2.5X6 MFZN2BL	Black	2	01
P70	QC399700	Pan Head Tapping Screw	2.6X6 FNM33G	Nickel	4	01
P80	QC187900	Bind Head Tapping Screw	3.0X5 ZMC2BL	Black	2	
P90	QC224900	Toothed Lock Washer	A3.0 ZMC2BL	Black	3	02
P100	EG330360	Bind Head Screw	3.0X6 MFZN2BL	Black	3	01
* P110	QC741600	Circuit Board	500N2	Pre-amplifier		
P120	--	Dust-proof Sheet		(QC39870)		
P130	--	Adhesive Tape		(QC39880)		

*: New Parts

RANK: Japan only

ELECTRICAL PARTS

REF NO.	PART NO.	DESCRIPTION		REMARKS	QTY	RANK
		ELECTRICAL PARTS		AEX500N-2		
*	QC741600	Circuit Board	500N2	Pre-amplifier (QC39810)		
*	QC741600	Circuit Board	500N2	Pre-amplifier (QC39810)		
	VT188900	LED Spacer	17.7L			02
*	QC398200	Angle Bracket				
	QC615300	Pan Head Screw	2.0X2.5		3	01
C1	AAX24920	Ceramic Capacitor (chip)	0.047uF K			
C2	UB013100	Ceramic Capacitor (chip)	1000pF K			01
C3	FX804250	Ceramic Capacitor (chip)	0.068uF K			
C4	UB045100	Ceramic Capacitor (chip)	0.1uF Z			01
C5	UI366100	Electrolytic Capacitor	1uF/50V			01
C6	UB014120	Ceramic Capacitor (chip)	0.012uF K			01
C7	AAX24920	Ceramic Capacitor (chip)	0.047uF K			
C8	UB013270	Ceramic Capacitor (chip)	2700pF K			01
C9	UB014100	Ceramic Capacitor (chip)	0.01uF K			01
C10	UI337220	Electrolytic Capacitor	22uF/16V			01
C11	UI337220	Electrolytic Capacitor	22uF/16V			01
C104	UB014100	Ceramic Capacitor (chip)	0.01uF K			01
* C107	UB045220	Ceramic Capacitor (chip)	0.22uF Z			
C108	UB052100	Ceramic Capacitor (chip)	100pF J			01
C109	UB051470	Ceramic Capacitor (chip)	47pF J			01
C110	UI366100	Electrolytic Capacitor	1uF/50V			01
C111	UB013220	Ceramic Capacitor (chip)	2200pF K			01
C112	UI337100	Electrolytic Capacitor	10uF/16V			01
CN1	LB918020	Connector	B2B-XH-A 2P	to Piezo Pickup		01
CN3	LB918020	Connector	B2B-XH-A 2P	to Battery		01
CN103	LB918030	Connector	B3B-XH-A 3P	to Output Jack		01
D1	VB797600	Diode (chip)	RLS-73			01
IC1	XN309A00	IC	TL062CPS	OP AMP		03
IC101	XN309A00	IC	TL062CPS	OP AMP		03
LED1	VG261500	LED	RE (3X5)	BATT.		01
R1	RD256100	Carbon Resistor (chip)	1.0K J			01
R2	RD259470	Carbon Resistor (chip)	4.7M J			01
R3	RD256330	Carbon Resistor (chip)	3.3K J			01
R4	RD256560	Carbon Resistor (chip)	5.6K J			01
R5	RD257150	Carbon Resistor (chip)	15K J			01
R6	RD257220	Carbon Resistor (chip)	22K J			01
R7	RD257120	Carbon Resistor (chip)	12K J			01
R8	RD257120	Carbon Resistor (chip)	12K J			01
R9	RD256390	Carbon Resistor (chip)	3.9K J			01
R10	RD256390	Carbon Resistor (chip)	3.9K J			01
R11	RD256220	Carbon Resistor (chip)	2.2K J			01
R12	RD258220	Carbon Resistor (chip)	220K J			01
R13	RD256150	Carbon Resistor (chip)	1.5K J			01
R14	RD257100	Carbon Resistor (chip)	10K J			01
R15	RD256220	Carbon Resistor (chip)	2.2K J			01
R16	RD257470	Carbon Resistor (chip)	47K J			01
R17	RD257470	Carbon Resistor (chip)	47K J			01
R19	RD256680	Carbon Resistor (chip)	6.8K J			01
R102	RD258470	Carbon Resistor (chip)	470K J			01
R103	RD256560	Carbon Resistor (chip)	5.6K J			01
R107	RD258100	Carbon Resistor (chip)	100K J			01
R108	RD257100	Carbon Resistor (chip)	10K J			01
R109	RD257470	Carbon Resistor (chip)	47K J			01
R110	RD256220	Carbon Resistor (chip)	2.2K J			01
R111	RD257470	Carbon Resistor (chip)	47K J			01
R112	RD257470	Carbon Resistor (chip)	47K J			01
RX1	XQ685A00	IC	RH5VL55AA	RESET		02
TR1	VQ986700	Transistor	2SC4081			01
VR1	HX808620	Slide Variable Resistor	50KB RA2043-20-15C	LOW		04
VR2	HX808620	Slide Variable Resistor	50KB RA2043-20-15C	HIGH		04
VR3	HX808620	Slide Variable Resistor	50KB RA2043-20-15C	MID		04

*: New Parts

RANK: Japan only

■ CIRCUIT BOARD

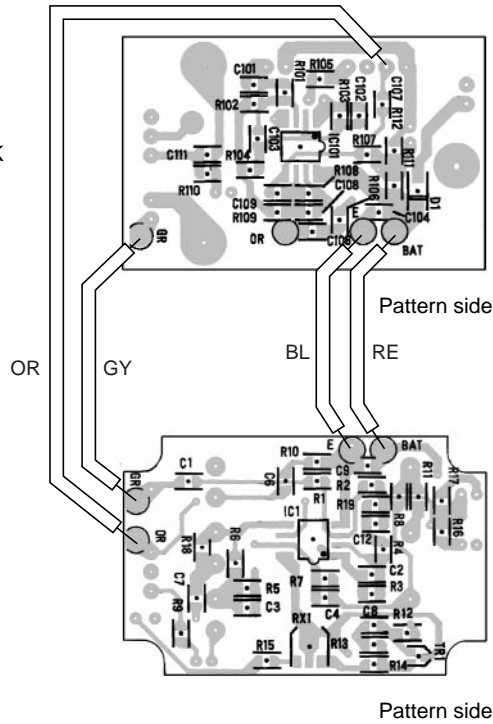
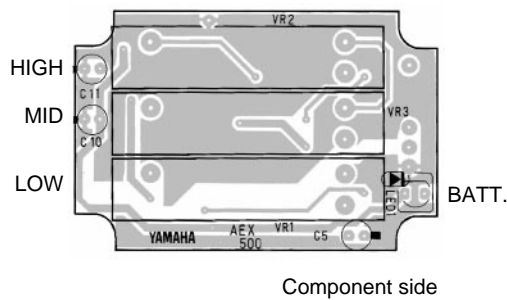
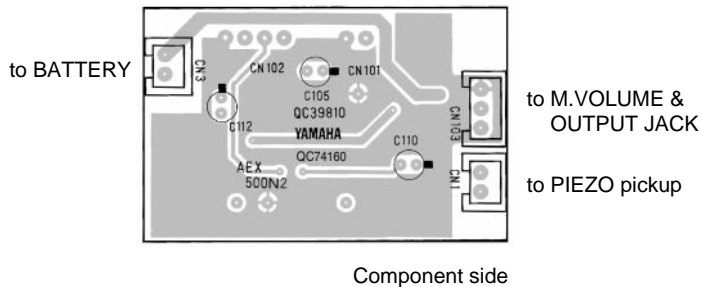

Note: See parts list for details of circuit board component parts.

QC74160

WARNING : CHEMICAL CONTENT NOTICE!

The solder used in the production of this product contains LEAD. In addition, other electrical/electronic and/or plastic (Where applicable) components may also contain traces of chemicals found by the California Health and Welfare Agency (and possibly other entities) to cause cancer and/or birth defects or other reproductive harm.

DO NOT PLACE SOLDER, ELECTRICAL/ELECTRONIC OR PLASTIC COMPONENTS IN YOUR MOUTH FOR ANY REASON WHAT SO EVER!

Avoid prolonged, unprotected contact between solder and your skin! When soldering, do not inhale solder fumes or expose eyes to solder/flux vapor!

If you come in contact with solder or components located inside the enclosure of this product, wash your hands before handling food.

CIRCUIT DIAGRAM

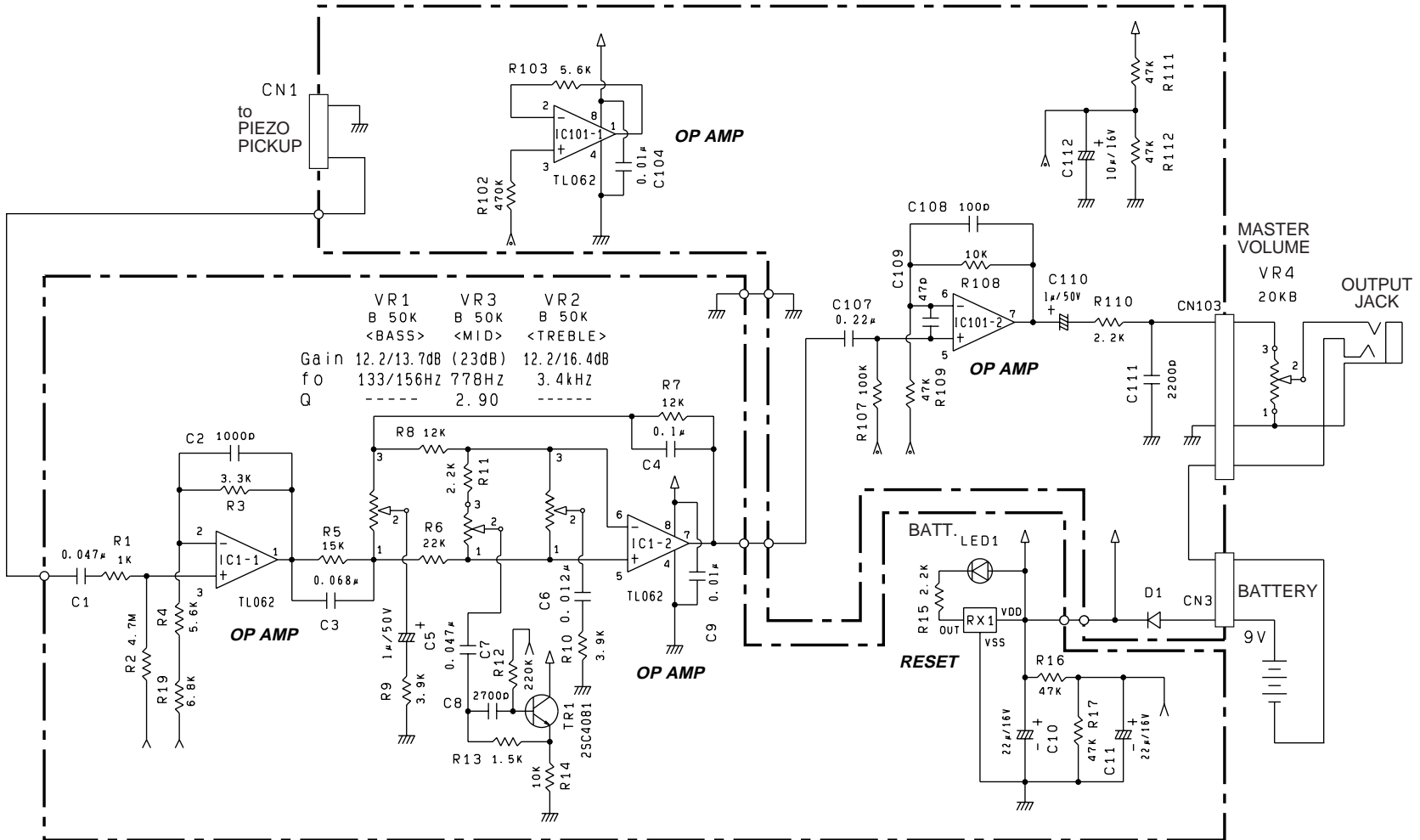

GA00P-02

■ WIRING

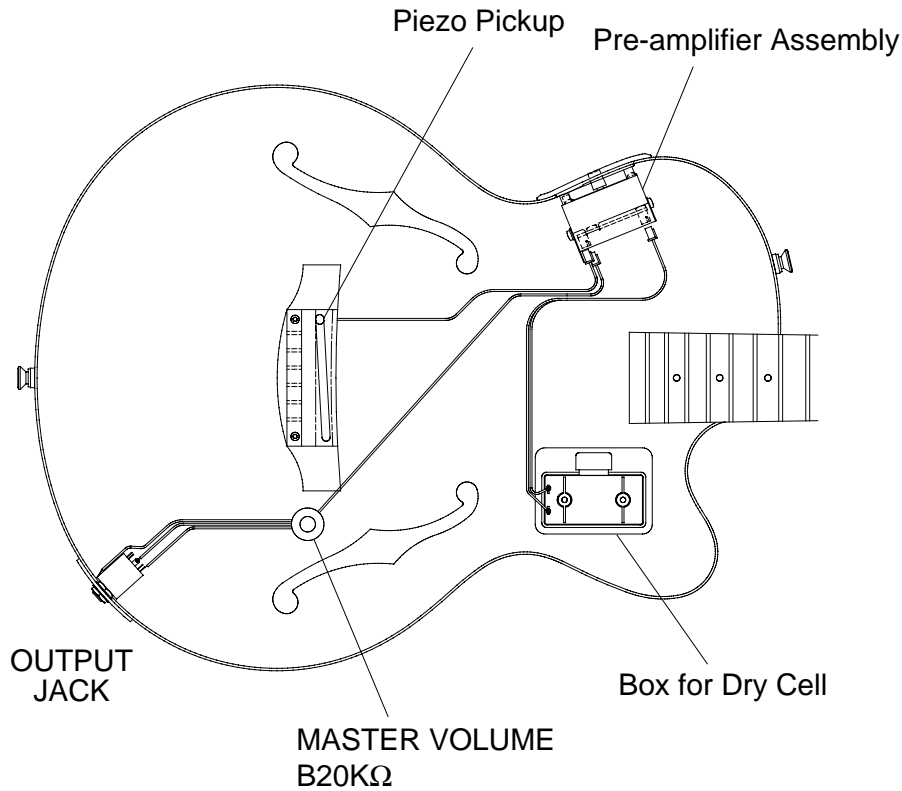

■ SPECIFICATIONS

● STANDARD SPECIFICATIONS

Scale Length	628.6mm
Body-Neck Construction	Bolt On
Length	979.0mm
Width	360.0mm
Net Weight	3.0kg

● COLOR

Body	
BL	Black
NT	Natural
Neck	
NT	Natural

● BODY

Material	Alder, Spruce
Body Depth	50.0mm

● FINGERBOARD

Material	Rosewood
Fingerboard Width	0-F 43.0 mm, 12-F 52.3 mm
No. of Frets	20

● NECK

Material	Maple
Neck Thickness	1-F 20.9 mm, 12-F 23.1 mm

● PARTS

Hardware	Gold Plated
Nut	Urea
Bridge	Indian Rosewood
Strings	S11-S16

● CONTROLS

Volume	B20KΩ x 1
--------------	-----------

● PICKUPS

Pickup	Piezo Pickup (HP-637)
--------------	-----------------------

Free Manuals Download Website

<http://myh66.com>

<http://usermanuals.us>

<http://www.somanuals.com>

<http://www.4manuals.cc>

<http://www.manual-lib.com>

<http://www.404manual.com>

<http://www.luxmanual.com>

<http://aubethermostatmanual.com>

Golf course search by state

<http://golfingnear.com>

Email search by domain

<http://emailbydomain.com>

Auto manuals search

<http://auto.somanuals.com>

TV manuals search

<http://tv.somanuals.com>