

ELECTRIC ACOUSTIC GUITAR CJX-12S SERVICE MANUAL

SYSTEM40

NOTE: See parts list of the SENSOR PICKUP SYSTEM40 (EG [011428](#)) service manual for details of the pre-amplifier assembly and the circuit board component parts.



CONTENTS

OVERALL ASSEMBLY	2
------------------------	---

WARNING : CHEMICAL CONTENT NOTICE!

The solder used in the production of this product contains LEAD. In addition, other electrical/electronic and/or plastic (Where applicable) components may also contain traces of chemicals found by the California Health and Welfare Agency (and possibly other entities) to cause cancer and/or birth defects or other reproductive harm.

DO NOT PLACE SOLDER, ELECTRICAL/ELECTRONIC OR PLASTIC COMPONENTS IN YOUR MOUTH FOR ANY REASON WHAT SO EVER!

Avoid prolonged, unprotected contact between solder and your skin! When soldering, do not inhale solder fumes or expose eyes to solder/flux vapor!

If you come in contact with solder or components located inside the enclosure of this product, wash your hands before handling food.

This document is printed on chlorine free (ECF) paper with soy ink.

EG [011599](#)
20010910-85000

 **YAMAHA**
HAMAMATSU, JAPAN

OVERALL ASSEMBLY

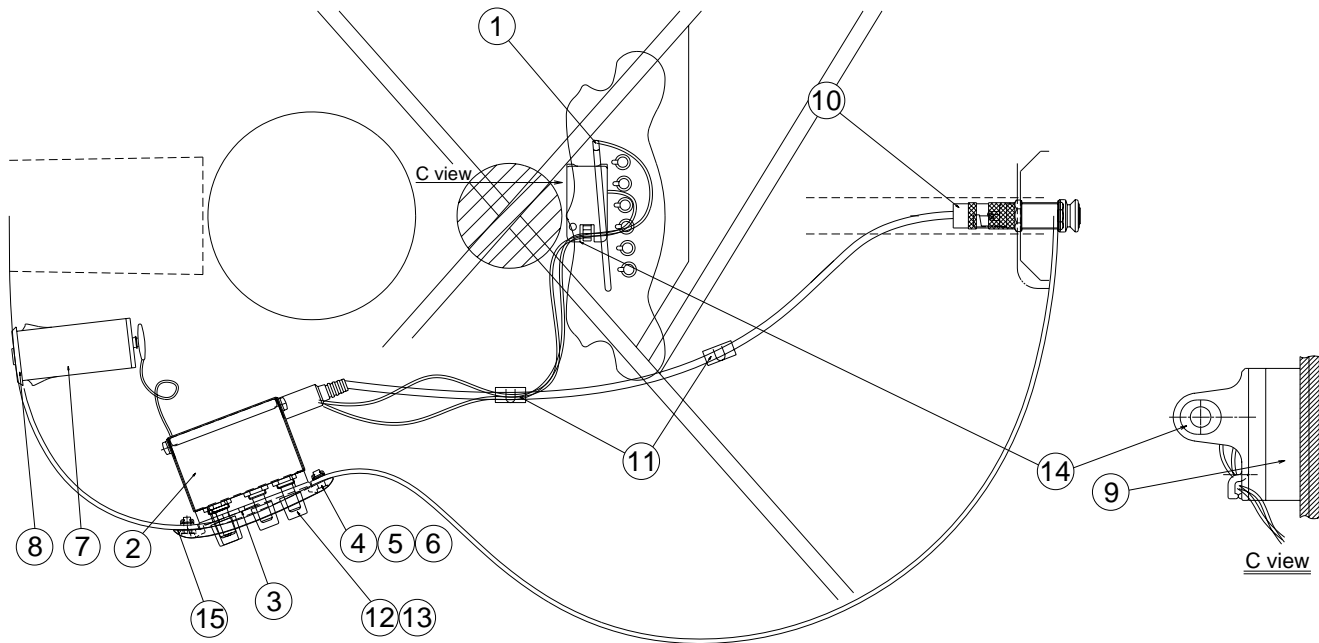

REF. NO.	PART NO.	DESCRIPTION		REMARKS	QTY	RANK
		OVERALL ASSEMBLY		CJX-12S		
1	V3033600	Pickup Assembly M	LR-Baggs			20
2	V3117200	Pre-amplifier Assembly				26
3	QC488100	Panel Y				06
4	QC271600	Pan Head Screw	3.0X10 Black		2	
5	QC271500	Floating Nut	0.6t		2	03
6	VT805400	Truss Head Screw	2.5X6 Black		4	01
7	QC111900	Battery Holder				05
8	QC112000	Cushion				03
9	V7959000	Cushion				
10	V3117300	Cord with End Pin Jack	DIN type	Output jack		12
11	VC668400	Cord Clamp			2	02
12	QC187800	Slide Knob	MONO		3	06
13	QC187700	Rotary Knob			4	05
14	V3033700	Pickup Assembly N	Condenser Mic			11
15	QC616300	Spacer, Amplifier	AMP-Z 1.0t			02

*: New Parts

RANK: Japan only

NOTE: When the pre-amplifier assembly is installed in the body, a gap may be created between the pre-amplifier assembly and the body by the difference in the form of the body. Only when this occurs, install the spacer of No.15 with the pre-amplifier assembly so that a gap isn't created.

Free Manuals Download Website

<http://myh66.com>

<http://usermanuals.us>

<http://www.somanuals.com>

<http://www.4manuals.cc>

<http://www.manual-lib.com>

<http://www.404manual.com>

<http://www.luxmanual.com>

<http://aubethermostatmanual.com>

Golf course search by state

<http://golfingnear.com>

Email search by domain

<http://emailbydomain.com>

Auto manuals search

<http://auto.somanuals.com>

TV manuals search

<http://tv.somanuals.com>