



 **READ THIS MANUAL CAREFULLY!**  
It contains important safety information.

**OWNER'S MANUAL**  
***RAPTOR190***  
**YFM90RY**

 **WARNING**

This ATV should not be ridden by anyone under 12 years of age.

**LIT-11626-22-13**

Download from [www.Somanuals.com](http://www.Somanuals.com). All Manuals Search And Download.

**43D-F8199-10**

**⚠ WARNING**

**The engine exhaust from this product contains chemicals known to the State of California to cause cancer, birth defects or other reproductive harm.**

YAMAHA

LIT-CALIF-65-01

**⚠** Read this manual carefully before operating this vehicle. This manual should stay with this vehicle if it is sold.

# INTRODUCTION

Congratulations on your purchase of the Yamaha YFM90RY. This ATV represents the result of many years of Yamaha experience in the production of fine sporting, touring, and pacesetting racing machines. With the purchase of this Yamaha, you can now appreciate the high degree of craftsmanship and reliability that have made Yamaha a leader in these fields.

This manual will provide you with a good basic understanding of the features and operation of this ATV. **This manual includes important safety information. It provides information about special techniques and skills necessary to ride the ATV.** It also includes basic maintenance and inspection procedures. If you have any questions regarding the operation or maintenance of your ATV, please consult a Yamaha dealer.

## **AN IMPORTANT SAFETY MESSAGE:**

- READ THIS MANUAL TOGETHER WITH TIPS FOR THE ATV RIDER CAREFULLY AND COMPLETELY BEFORE OPERATING YOUR ATV. MAKE SURE YOU UNDERSTAND ALL INSTRUCTIONS.
- PAY CLOSE ATTENTION TO THE WARNING AND NOTICE LABELS ON THE ATV.
- NEVER OPERATE AN ATV WITHOUT PROPER TRAINING OR INSTRUCTION. FREE TRAINING IS AVAILABLE TO ANYONE WHO BUYS A NEW ATV. CALL 1-800-887-2887 FOR MORE INFORMATION.
- THIS ATV, AND ANY OTHER ATV OVER 70 cc, SHOULD NOT BE OPERATED BY A CHILD UNDER 12 YEARS OF AGE.

## **AN IMPORTANT NOTE TO PARENTS:**

This ATV is not a toy. Before you let your child ride this ATV, you should understand the instructions and warnings in this Owner's Manual. Then be sure your child understands and will follow them. Children differ



in skills, physical abilities and judgment. Some children may not be able to operate an ATV safely. Parents should supervise their child's use of the ATV at all times. Parents should permit continued use only if they determine that the child has the ability to operate the ATV safely.

Your ATV was delivered with an adjustable speed limiter . Yamaha recommends that all beginners start off to limit the amount of speed available while they learn. The adjusting screw may be gradually turned out as the beginner becomes more familiar with operating the ATV. Parents should decide when to adjust the ATV for more power as their youngster's riding skills improve. Once the ATV rider can operate with skill at the top speed permitted by adjusting the vehicle speed limiter alone, the engine speed limiter plate can be removed. Since removal of this limiter will result in a significant increase in power, turn the vehicle speed limiter adjusting screw completely back in again; adjust it out in stages as done previously. If your child is a beginner or is inexperienced, he or she should take a training course. See the previous page for information about the free training available to purchasers of new ATVs.

# IMPORTANT MANUAL INFORMATION

FAILURE TO FOLLOW THE WARNINGS CONTAINED IN THIS MANUAL CAN RESULT IN SERIOUS INJURY OR DEATH.

Particularly important information is distinguished in this manual by the following notations:

	<b>This is the safety alert symbol. It is used to alert you to potential personal injury hazards. Obey all safety messages that follow this symbol to avoid possible injury or death.</b>
	<b>A WARNING indicates a hazardous situation which, if not avoided, could result in death or serious injury.</b>
	<b>A NOTICE indicates special precautions that must be taken to avoid damage to the vehicle or other property.</b>
<b>TIP</b>	<b>A TIP provides key information to make procedures easier or clearer.</b>

\* Product and specifications are subject to change without notice.

## IMPORTANT NOTICE

Welcome to the Yamaha world of motor sports!

This ATV is designed and manufactured for OFF-ROAD use only. It is illegal and unsafe to operate this ATV on any public street, road or highway.

This ATV complies with all applicable OFF-ROAD noise level and spark arrester laws and regulations in effect at the time of manufacture.

Please check your local riding laws and regulations before operating this ATV.

**YFM90RY  
OWNER'S MANUAL  
©2008 by Yamaha Motor Corporation, U.S.A.  
1st edition, July 2008  
All rights reserved.  
Any reprinting or unauthorized use  
without the written permission of  
Yamaha Motor Corporation, U.S.A.  
is expressly prohibited.  
Printed in Taiwan.  
P/N LIT-11626-22-13**

## **WARNING**

**A WARNING indicates a hazardous situation which, if not avoided, could result in death or serious injury.**

## TABLE OF CONTENTS

SAFETY INFORMATION.....	1-1
LOCATION OF THE WARNING AND SPECIFICATION LABELS.....	2-1
DESCRIPTION .....	3-1
Left view.....	3-1
Right view.....	3-1
Controls and instruments.....	3-2
INSTRUMENT AND CONTROL FUNCTIONS.....	4-1
Main switch.....	4-1
Handlebar switches .....	4-2
Throttle lever .....	4-3
Speed limiters.....	4-3
Vehicle speed limiter .....	4-4
Engine speed limiter plate.....	4-5
Front brake lever .....	4-6

Rear brake lever .....	4-6
Parking brake .....	4-7
Fuel tank cap .....	4-8
Fuel .....	4-8
Fuel cock .....	4-10
Choke .....	4-11
Seat .....	4-11
Kick starter .....	4-12

PRE-OPERATION CHECKS.....	5-1
Pre-operation check list.....	5-1
Fuel .....	5-3
Engine oil .....	5-3
Final transmission oil .....	5-3
Front and rear brakes .....	5-3
Throttle lever .....	5-4
Tires .....	5-4
Measuring the tire pressure .....	5-5
Tire wear limit .....	5-6
Chassis fasteners .....	5-7
Instruments and switches .....	5-7
OPERATION.....	6-1
Starting a cold engine .....	6-1
Starting a warm engine .....	6-3
Engine break-in .....	6-4
Parking .....	6-4
Parking on a slope .....	6-5
Accessories and loading .....	6-6

RIDING YOUR ATV .....	7-1	Cleaning the spark arrester .....	8-19
GETTING TO KNOW YOUR ATV.....	7-2	Adjusting the carburetor .....	8-20
RIDE WITH CARE AND GOOD JUDGEMENT .....	7-2	Adjusting the engine idling speed .....	8-20
BE CAREFUL WHERE YOU RIDE.....	7-11	Checking the throttle cable free play .....	8-21
TURNING YOUR ATV.....	7-15	Timing chain .....	8-22
CLIMBING UPHILL.....	7-17	Brakes .....	8-22
RIDING DOWNHILL.....	7-20	Valve clearance .....	8-22
CROSSING A SLOPE.....	7-21	Checking the front brake shoes.....	8-22
CROSSING THROUGH SHALLOW WATER .....	7-22	Adjusting the front brake lever free play .....	8-23
RIDING OVER ROUGH TERRAIN.....	7-24	Checking the rear brake pads .....	8-25
SLIDING AND SKIDDING.....	7-25	Checking the brake fluid level .....	8-25
WHAT TO DO IF.....	7-26	Changing the rear brake fluid .....	8-26
WHAT TO DO... .....	7-26	Checking the rear brake lever free play .....	8-26
PERIODIC MAINTENANCE AND MINOR REPAIR.....	8-1	Checking and lubricating the cables.....	8-27
Owner's manual and tool kit .....	8-1	Checking and lubricating the front and rear brake levers.....	8-27
Periodic maintenance chart for the emission control system .....	8-3	Checking the wheel hub bearings .....	8-28
General maintenance and lubrication chart .....	8-5	Battery .....	8-28
Checking the spark plug .....	8-9	Replacing the fuse .....	8-30
Engine oil .....	8-11	Removing a wheel .....	8-32
Final transmission oil .....	8-14	Installing a wheel .....	8-33
Cleaning the air filter element .....	8-15	Troubleshooting .....	8-34
		Troubleshooting chart .....	8-35
		CLEANING AND STORAGE.....	9-1
		Cleaning .....	9-1
		Storage .....	9-2



SPECIFICATIONS .....	10-1
CONSUMER INFORMATION .....	11-1
Identification numbers .....	11-1
Noise regulation .....	11-3
Maintenance record .....	11-4
YAMAHA MOTOR CORPORATION, U.S.A. ATV LIMITED WARRANTY .....	11-5
YAMAHA EXTENDED SERVICE (Y.E.S.) .....	11-7



## SAFETY INFORMATION

### **AN ATV IS NOT A TOY AND CAN BE HAZARDOUS TO OPERATE.**

An ATV handles differently from other vehicles, including motorcycles and cars. A collision or roll-over can occur quickly, even during routine maneuvers such as turning and riding on hills or over obstacles, if you fail to take proper precautions.

SEVERE INJURY OR DEATH can result if you do not follow these instructions:

- Read this manual and all labels carefully and follow the operating procedures described.
- Never operate an ATV without proper training or instruction. **Take a Training Course.** Beginners should receive training from a certified instructor. Contact an authorized ATV dealer or call 1-800-887-2887 to find out about the training courses nearest you.
- Always follow the age recommendation:

- A child under 12 years old should never operate an ATV with engine size greater than 70 cc.
- A child under 16 years old should never operate an ATV with engine size greater than 90 cc.

- Never allow a child under age 16 to operate an ATV without adult supervision, and never allow continued use of an ATV by a child if he or she does not have the abilities to operate it safely.
- Never carry a passenger on an ATV.
- Always avoid operating an ATV on any paved surfaces, including sidewalks, driveways, parking lots and streets.
- Never operate an ATV on any public street, road or highway, even a dirt or gravel one.
- Never operate an ATV without wearing an approved motorcycle helmet that fits properly. You should also wear eye protection (goggles or face shield), gloves, boots, a long-sleeved shirt or a jacket, and long pants.
- Never consume alcohol or drugs before or while

operating this ATV.

- Never operate at speeds too fast for your skills or the riding conditions. Always go at a speed that is proper for the terrain, visibility, operating conditions, and your experience.
- Never attempt wheelies, jumps, or other stunts.
- Always inspect your ATV each time you use it to make sure it is in safe operating condition. Always follow the inspection and maintenance procedures and schedules described in this manual.
- Always keep both hands on the handlebars and both feet on the footrests of the ATV during operation.
- Always go slowly and be extra careful when operating on unfamiliar terrain. Always be alert to changing terrain conditions when operating the ATV.
- Never operate on excessively rough, slippery or loose terrain until you have learned and practiced the skills necessary to control the ATV on such terrain. Always be especially cautious on these kinds of terrain.
- Always follow proper procedures for turning as described in this manual. Practice turning at low speeds before attempting to turn at faster

speeds and never turn at excessive speeds.

- Never operate the ATV on hills too steep for the ATV or for your abilities. Practice on smaller hills before attempting larger hills.
- Always follow proper procedures for climbing hills as described in this manual. Check the terrain carefully before you start up any hill. Never climb hills with excessively slippery or loose surfaces. Shift your weight forward. Never open the throttle suddenly or make sudden gear changes. Never go over the top of a hill at high speed.
- Always follow proper procedures for going down hills and for braking on hills as described in this manual. Check the terrain carefully before you start down any hill. Shift your weight backward. Never go down a hill at high speed. Avoid going down a hill at an angle that would cause the vehicle to lean sharply to one side. Go straight down the hill where possible.
- Always follow proper procedures for crossing the side of a hill as described in this manual. Avoid hills with excessively slippery or loose surfaces. Shift your weight to the uphill side of the ATV. Never attempt to turn the ATV around on any hill until you have mastered the turning technique described in this manual on level ground.

- Avoid crossing the side of a steep hill if possible.
- Always use proper procedures if you stall or roll backwards when climbing a hill. To avoid stalling, use the proper gear and maintain a steady speed when climbing a hill. If you stall or roll backwards, follow the special procedure for braking described in this manual. Dismount on the uphill side or to a side if pointed straight uphill. Turn the ATV around and remount, following the procedure described in this manual.
  - Always check for obstacles before operating in a new area.
  - Never attempt to operate over large obstacles, such as large rocks or fallen trees. Always follow proper procedures when operating over obstacles as described in this manual.
  - Always be careful when skidding or sliding. Learn to safely control skidding or sliding by practicing at low speeds and on level, smooth terrain. On extremely slippery surfaces, such as ice, go slowly and be very cautious in order to reduce the chance of skidding or sliding out of control.
  - Never operate an ATV in fast flowing water or in water deeper than that recommended in this manual. Remember that wet brakes may have

reduced stopping ability. Test your brakes after leaving water. If necessary, apply them several times to let friction dry out the linings.

- Always use the size and type of tires specified in this manual.
- Always maintain proper tire pressure as described in this manual.
- Never modify an ATV through improper installation or use of accessories.
- Never exceed the stated load capacity for an ATV. Cargo should be properly distributed and securely attached. Reduce speed and follow instructions in this manual for carrying cargo or pulling a trailer. Allow greater distance for braking.

**FOR MORE INFORMATION ABOUT ATV SAFETY**, call the Consumer Products Safety Commission at 1-800-638-2772, or the ATV Distributor's Safety Hotline at 1-800-852-5344.

 **WARNING**

**POTENTIAL HAZARD**

**Improper handling of gasoline.**

**WHAT CAN HAPPEN**

**Gasoline can catch fire and you could be burned.**

### HOW TO AVOID THE HAZARD

Always turn off the engine when refueling.  
Do not refuel right after the engine has been running and is still very hot.

Do not spill gasoline on the engine or exhaust pipe/muffler when refueling.

Never refuel while smoking, or in the vicinity of sparks, open flames, or other sources of ignition such as the pilot lights of water heaters and clothes dryers.

When transporting the ATV in another vehicle, be sure it is kept upright and that the fuel cock is in the "OFF" position. Otherwise, fuel may leak out of the carburetor or fuel tank.

### WHAT CAN HAPPEN

Gasoline is poisonous and can cause injuries.

### HOW TO AVOID THE HAZARD

If you should swallow some gasoline or inhale a lot of gasoline vapor, or get some gasoline in your eyes, seek medical help immediately. If gasoline spills on your skin, wash with soap and water. If gasoline spills on your clothing, change your clothes.



### **⚠ WARNING**

#### POTENTIAL HAZARD

Starting or running the engine in a closed area.

#### WHAT CAN HAPPEN

Exhaust fumes are poisonous and may cause loss of consciousness and death within a short time.

#### HOW TO AVOID THE HAZARD

Always operate your ATV in an area with adequate ventilation.

# LOCATION OF THE WARNING AND SPECIFICATION LABELS

2

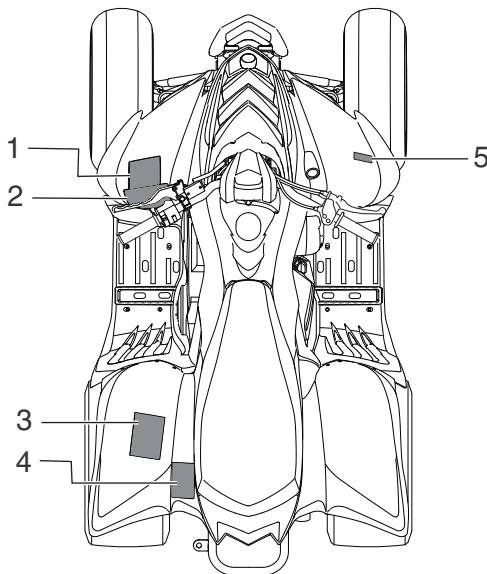

Read and understand all of the labels on your ATV. These labels contain important information for safe and proper operation.

Never remove any labels from your ATV. If a label becomes difficult to read or comes off, request a replacement label from your Yamaha dealer.

1

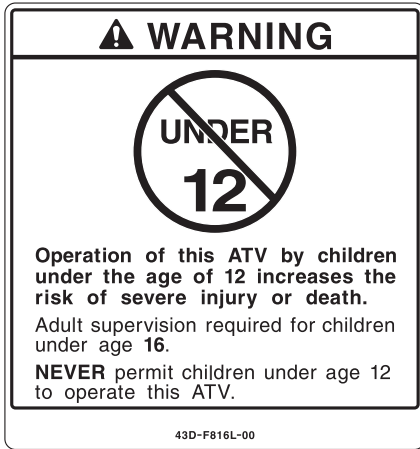

2



2

3

**⚠ WARNING**

Improper tire pressure or overloading can cause loss of control.  
Loss of control can result in severe injury or death.

**OPERATING TIRE PRESSURE :** Set with tires cold

- Recommended : Front : **3.6 psi ( 25.0 kPa )**  
Rear : **3.6 psi ( 25.0 kPa )**
- Minimum : Front : **3.2 psi ( 22.0 kPa )**  
Rear : **3.2 psi ( 22.0 kPa )**
- Never set tire pressure below minimum.  
It could cause the tire to dislodge from the rim.

**LOADING**

- Maximum weight capacity : **154 lbs. ( 70 kg )**  
Includes weight of operator, cargo and accessories.

43D-F816M-00

4

**⚠ WARNING**

**NEVER ride as a passenger.**

**Passengers can cause a loss of control, resulting in SEVERE INJURY or DEATH.**



43D-F151H-00

5

YAMAHA certifies that this ATV complies with the American National Standard for Four Wheel All-Terrain Vehicles, ANSI/SVIA 1-2007 Standard.

43D-F817J-00



# DESCRIPTION

## Left view

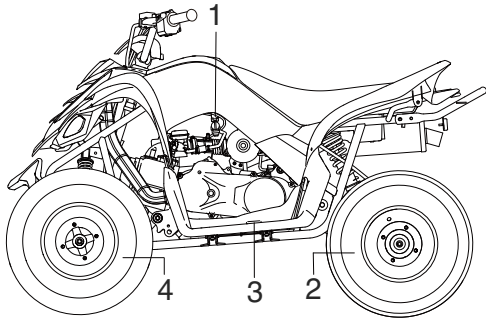

1. Fuel cock
2. Rear wheel
3. Footrest
4. Front wheel

## Right view

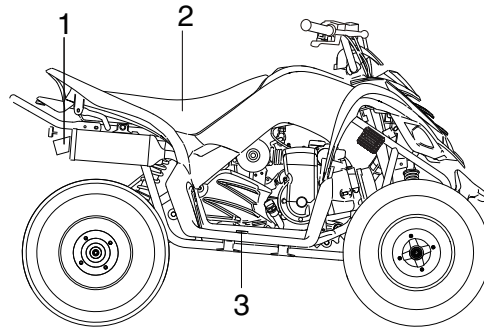

1. Spark arrester
2. Seat
3. Footrest

## Controls and instruments

**TIP** \_\_\_\_\_

The ATV you have purchased may differ slightly from the figures shown in this manual.

---

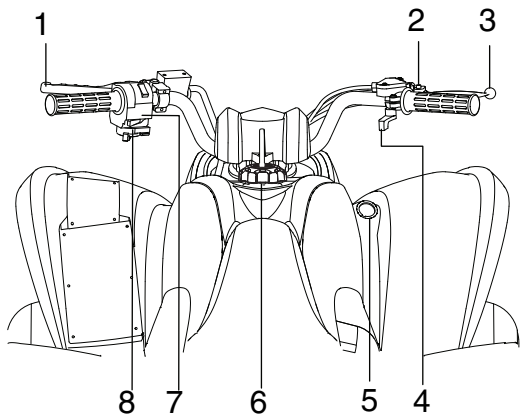

3

1. Rear brake lever
2. Parking brake
3. Front brake lever
4. Throttle lever
5. Main switch
6. Fuel tank cap
7. Handlebar switches
8. Choke

# INSTRUMENT AND CONTROL FUNCTIONS

## **⚠ WARNING**

A **WARNING** indicates a hazardous situation which, if not avoided, could result in death or serious injury.

## **Main switch**

The positions of the main switch are as follows:

### **ON**

All electrical systems are supplied with power, and the engine can be started. The key cannot be removed.

### **OFF**

All electrical systems are off. The key can be removed.

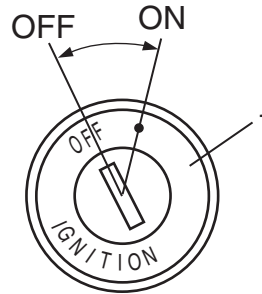

1. Main switch

## Handlebar switches

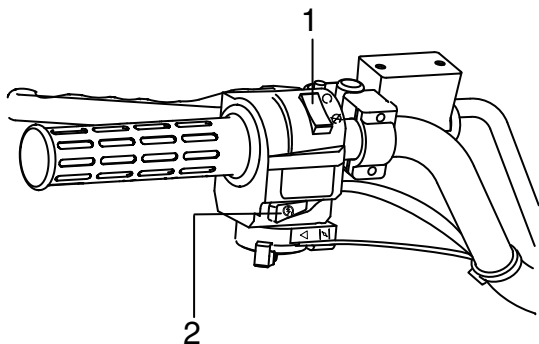

1. Engine stop switch "ENG. STOP"
2. Start switch "START"

### Engine stop switch "ENG. STOP"

Set this switch to "RUN" before starting the engine. The engine stop switch controls the ignition and stops the engine when it is running. Use this switch to stop the engine in an emergency situation. The engine will not start or run when this switch is set to "OFF".

### Start switch "START"

Push this switch to crank the engine with the starter. See the starting instructions on page 6-1 prior to starting the engine.

## Throttle lever

Once the engine is running, movement of the throttle lever will increase the engine speed.

Regulate the speed of the ATV by varying the throttle position. Because the throttle is spring-loaded, the ATV will decelerate, and the engine will return to an idle any time the hand is removed from the throttle lever.

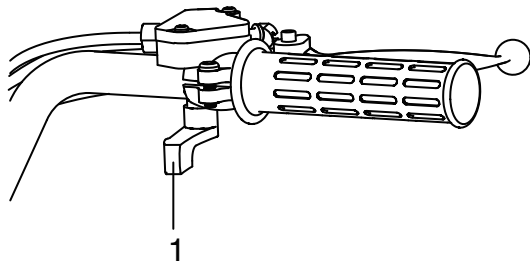

1. Throttle lever

Before starting the engine, check the throttle to be sure it is operating smoothly. Make sure it returns to the idle position as soon as the lever is released.

## WARNING

### **POTENTIAL HAZARD**

**Malfunction of throttle.**

### **WHAT CAN HAPPEN**

The throttle could be hard to operate, making it difficult to speed up or slow down when you need to. This could cause an accident.

### **HOW TO AVOID THE HAZARD**

Check the operation of the throttle lever before you start the engine. If it does not work smoothly, check for the cause. Correct the problem before riding the ATV. Consult a Yamaha dealer if you can't find or solve the problem yourself.

4

## Speed limiters

Your ATV was delivered with two speed limiter devices. A vehicle speed limiter adjusting screw and a removable engine speed limiter plate. Yamaha recommends that all beginning riders start off with the vehicle speed limiter adjusting screw fully turned in and the engine speed limiter plate installed to limit the amount of speed available while they learn.

The vehicle speed limiter keeps the throttle from fully opening, even when the throttle lever is pushed to the maximum. The adjusting screw may be gradually turned out as the beginner becomes more familiar with operating the ATV. Parents should decide when to adjust the ATV for more power as their youngster's riding skills improve. Once the ATV rider can operate with skill at the top speed permitted by adjusting the vehicle speed limiter alone, the engine speed limiter plate can be removed. Since removal of this limiter will result in a significant increase in power, turn the vehicle speed limiter adjusting screw completely back in again; adjust it out in stages as done previously.

## Vehicle speed limiter

1. Loosen the locknut.
2. To increase the maximum engine power available and the maximum speed of the ATV, turn the adjusting screw in direction (a). To decrease the maximum engine power available and the maximum speed of the ATV, turn the adjusting screw in direction (b).

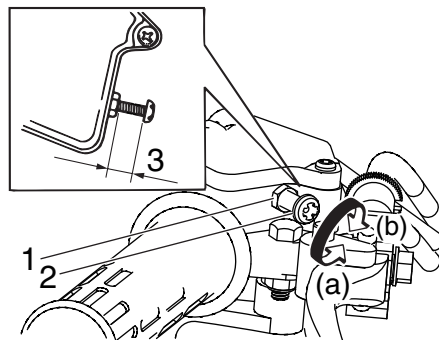

1. Locknut
  2. Adjusting screw
  3. No more than 11 mm (0.4 in)
3. Tighten the locknut.

**WARNING**

**POTENTIAL HAZARD**

Improper adjustment of the speed limiter and throttle.

**WHAT CAN HAPPEN**

The throttle cable could be damaged. Improper throttle operation could result. The child could lose control, have an accident or be injured.

**HOW TO AVOID THE HAZARD**

Do not turn the adjusting screw out more than 5 mm (0.2 in).

4. Tighten the screw.
5. Install the seat.

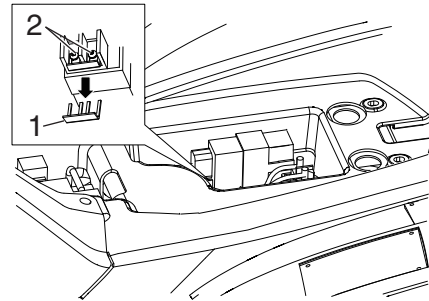

1. Speed limiter plate
2. Screws

## Engine speed limiter plate

With this plate installed, the engine speed is limited to 4800 r/min. With this plate removed, top engine speed (8000 r/min) is available.

Remove the plate as follows.

1. Remove the seat. (See page 4-11.)
2. Loosen the screws.
3. Pull the plate out of its case.

### TIP

Store the speed limiter plate with the owner's manual so that it is readily available whenever you want to reduce the top engine speed.

## Front brake lever

The front brake lever is located on the right handlebar. To apply the front brake, pull the brake lever toward the handlebar grip.

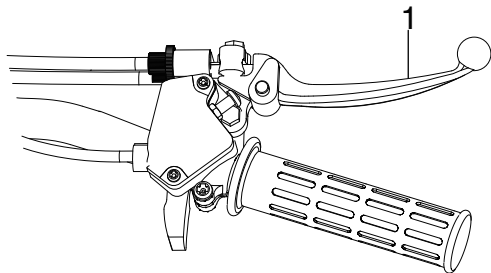

1. Front brake lever

## Rear brake lever

The rear brake lever is located on the left handlebar. To apply the rear brake, pull the brake lever toward the handlebar grip.

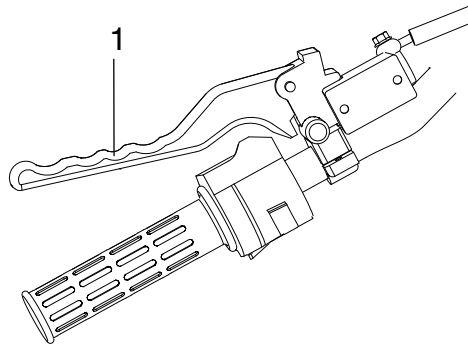

1. Rear brake lever



## Parking brake

Use the parking brake before starting the engine or parking the ATV, especially on a slope. Apply the front brake lever and push down the lock button to apply the parking brake. Squeeze the front brake lever to release the parking brake.

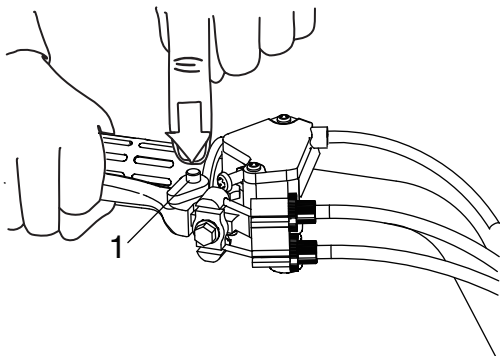

1. Parking brake lock button

## WARNING

### POTENTIAL HAZARD

Improper use of the parking brake.

### WHAT CAN HAPPEN

The ATV could start moving unexpectedly if the parking brake is not applied before starting the engine. This could cause loss of control or a collision.

The brake could overheat if you ride the ATV without releasing the parking brake. You could lose braking performance which could cause an accident. You could also wear out the brakes prematurely.

### HOW TO AVOID THE HAZARD

Always set the parking brake before starting the engine.

Always be sure you have released the parking brake before you begin to ride.

## Fuel tank cap

Remove the fuel tank cap by turning it counter-clockwise.

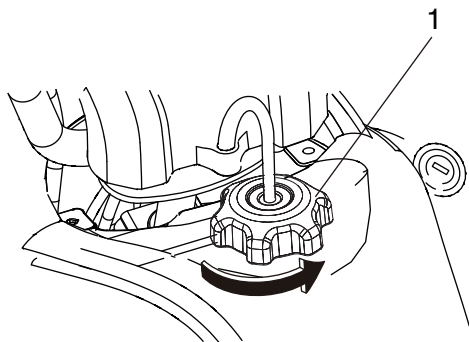

1. Fuel tank cap

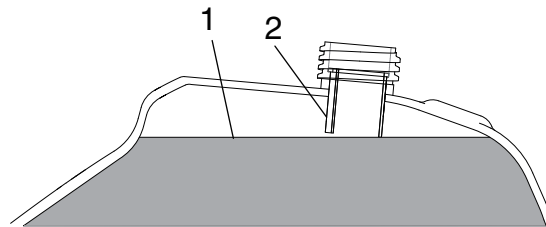

1. Fuel level
2. Filler tube

Recommended fuel:  
**UNLEADED GASOLINE ONLY**

Fuel tank capacity:  
4.8 L (1.27 US gal) (1.06 Imp.gal)

Fuel reserve amount:  
1.0 L (0.26 US gal) (0.22 Imp.gal)

## Fuel

Make sure that there is sufficient fuel in the tank. Fill the fuel tank to the bottom of the filler tube as shown.

## NOTICE

**Use only unleaded gasoline. The use of leaded gasoline will cause severe damage to internal engine parts, such as the valves and piston rings, as well as to the exhaust system.**

Your Yamaha engine has been designed to use regular unleaded gasoline with a pump octane number  $[(R+M)/2]$  of 86 or higher, or a research octane number of 91 or higher. If knocking or pinging occurs, use a different brand of gasoline or premium unleaded fuel. Unleaded fuel will give you longer spark plug life and reduced maintenance cost.

### Gasohol

There are two types of gasohol: gasohol containing ethanol and that containing methanol. Gasohol containing ethanol can be used if the ethanol content does not exceed 10%. Gasohol containing methanol is not recommended by Yamaha because it can cause damage to the fuel system or ATV performance problems.

## WARNING

### POTENTIAL HAZARD

**Improper care when refueling.**

### WHAT CAN HAPPEN

**Fuel can spill, which can cause a fire and severe injury.**

**Fuel expands when it heats up. If the fuel tank is overfilled, fuel could spill out due to heat from the engine or the sun.**

### HOW TO AVOID THE HAZARD

**Do not overfill the fuel tank. Be careful not to spill fuel, especially on the engine or exhaust pipe. Wipe up any spilled fuel immediately. Be sure the fuel tank cap is closed securely. Do not refuel right after the engine has been running and is still very hot.**

## Fuel cock

The fuel cock supplies fuel from the tank to the carburetor while also filtering it.

The fuel cock lever positions are explained as follows and shown in the illustrations.

### OFF

4

1. Lever positioned over "OFF"

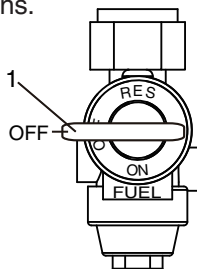

With the fuel cock lever in this position, fuel will not flow. Always turn the fuel cock lever to this position when the engine is not running.

### ON

1. Lever positioned over "ON"

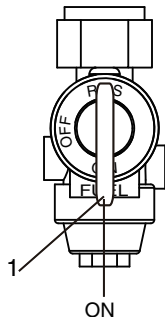

With the fuel cock lever in this position, fuel flows to the carburetor. Turn the fuel cock lever to this position when starting the engine and riding.

### RES

1. Lever positioned over "RES"

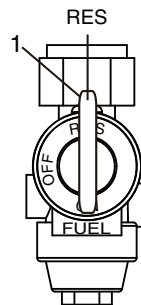

This indicates reserve. With the fuel cock lever in this position, the fuel reserve is made available. Turn the fuel cock lever to this position if you run out of fuel while riding. When this occurs, refuel as soon as possible and be sure to turn the fuel cock lever back to "ON"!

## Choke

The choke is used to start a cold engine. Move the choke in direction (a) to turn on the choke.

Move the choke in direction (b) to turn off the choke.

See the “Starting a cold engine” section on page 6-1 for proper operation.

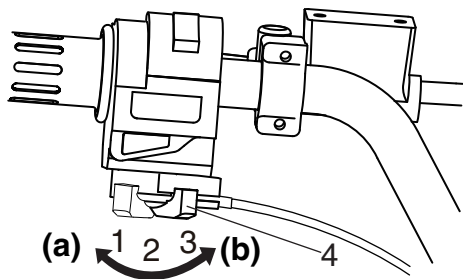

1. Fully open “ON”
2. Half open (warming up position)
3. Closed “OFF”
4. Choke

## Seat

### To remove the seat

Pull the seat lock lever upward and pull up the seat at the rear.

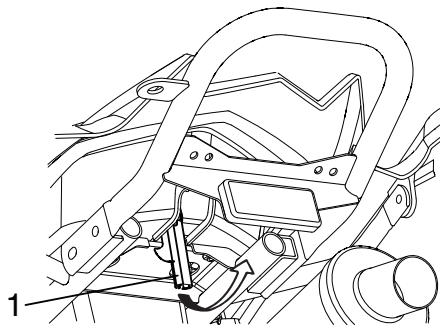

1. Seat lock lever

## To install the seat

Insert the projection on the front of the seat into the seat holder and push down on the seat at the rear.

### TIP

Make sure that the seat is securely fitted.

4

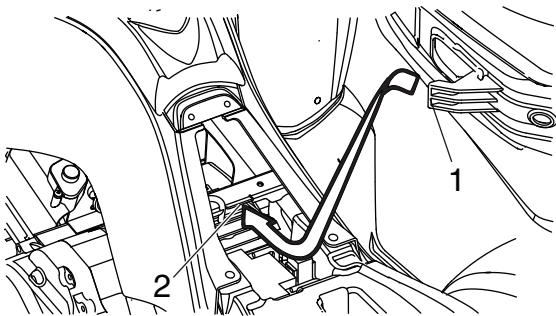

1. Projection
2. Seat holder

## Kickstarter

A kickstarter lever is located under the seat to use if the battery is discharged.

1. Install the kickstarter lever.

2. Move the kickstarter lever down lightly with your foot until the gears engage, and then push it down smoothly but forcefully.

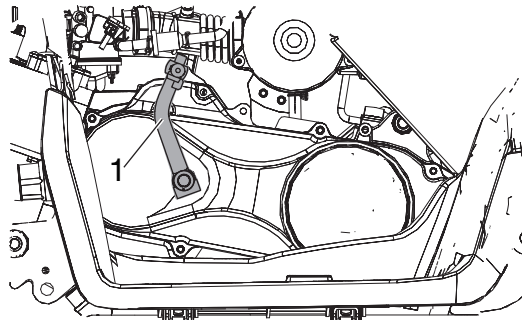

1. Kickstarter

### NOTICE

Do not use the kickstarter if there is no battery installed or if the battery leads are disconnected.

### ⚠ WARNING

A **WARNING** indicates a hazardous situation which, if not avoided, could result in death or serious injury.

# PRE-OPERATION CHECKS

## Pre-operation check list

Before operating this ATV, be sure to check the items listed in the following table.

### WARNING

#### **POTENTIAL HAZARD**

Failure to inspect the ATV before operating.

Failure to properly maintain the ATV.

#### **WHAT CAN HAPPEN**

Increases the possibility of an accident or equipment damage.

#### **HOW TO AVOID THE HAZARD**

Always inspect your ATV each time you use it to make sure it is in safe operating condition.

Always follow the inspection and maintenance procedures and schedules described in the Owner's Manual.

### **TIP**

The maintenance of some items in the table has to be performed by a Yamaha dealer. Refer to the "Periodic maintenance and lubrication charts" on page 8-3 to determine which service should be performed by a Yamaha dealer.

ITEM	ROUTINE	PAGE
<b>Fuel</b>	<ul style="list-style-type: none"> <li>• Check fuel level in fuel tank, and add recommended fuel if necessary.</li> <li>• Check fuel line for leakage. Correct if necessary.</li> </ul>	4-8, 5-3
<b>Engine oil</b>	<ul style="list-style-type: none"> <li>• Check oil level in engine, and add recommended oil to specified level if necessary.</li> <li>• Check ATV for oil leakage. Correct if necessary.</li> </ul>	5-3, 8-11
<b>Final transmission oil</b>	<ul style="list-style-type: none"> <li>• Check ATV for oil leakage. Correct if necessary.</li> </ul>	5-3, 8-14
<b>Front brake</b>	<ul style="list-style-type: none"> <li>• Check operation, and correct if necessary.</li> <li>• Lubricate cable if necessary.</li> <li>• Check lever free play, and adjust if necessary.</li> </ul>	5-3, 8-22, 8-23
<b>Rear brake</b>	<ul style="list-style-type: none"> <li>• Check operation. If soft or spongy, have Yamaha dealer bleed hydraulic system.</li> <li>• Check brake pads for wear, and replace if necessary.</li> <li>• Check brake fluid level in reservoir, and add recommended brake fluid to specified level if necessary.</li> <li>• Check hydraulic system for leakage. Correct if necessary.</li> </ul>	5-3, 8-25, 8-26
<b>Throttle lever</b>	<ul style="list-style-type: none"> <li>• Make sure that operation is smooth, and check cable free play.</li> <li>• Lubricate cable and lever housing if necessary.</li> </ul>	5-4, 8-21
<b>Control cables</b>	<ul style="list-style-type: none"> <li>• Make sure that operation is smooth. Lubricate if necessary.</li> </ul>	8-27
<b>Wheels and tires</b>	<ul style="list-style-type: none"> <li>• Check wheel condition, and replace if damaged.</li> <li>• Check tire condition and tread depth. Replace if necessary.</li> <li>• Check air pressure. Correct if necessary.</li> </ul>	5-4, 5-5, 5-6
<b>Brake levers</b>	<ul style="list-style-type: none"> <li>• Make sure that operation is smooth. Lubricate lever pivoting points if necessary.</li> </ul>	8-27
<b>Chassis fasteners</b>	<ul style="list-style-type: none"> <li>• Make sure that all nuts, bolts and screws are properly tightened.</li> </ul>	5-7
<b>Instruments and switches</b>	<ul style="list-style-type: none"> <li>• Check operation, and correct if necessary.</li> </ul>	5-7



## Fuel

Make sure that there is sufficient fuel in the tank. (See page 4-8.)

### **WARNING**

#### **POTENTIAL HAZARD**

**Improper care when refueling.**

#### **WHAT CAN HAPPEN**

**Fuel can spill, which can cause a fire and severe injury.**

**Fuel expands when it heats up. If the fuel tank is overfilled, fuel could spill out due to heat from the engine or the sun.**

#### **HOW TO AVOID THE HAZARD**

**Do not overfill the fuel tank. Be careful not to spill fuel, especially on the engine or exhaust pipe. Wipe up any spilled fuel immediately. Be sure the fuel tank cap is closed securely. Do not refuel right after the engine has been running and is still very hot.**

## Engine oil

Make sure that the engine oil is at the specified level. Add oil as necessary. (See page 8-11.)

## Final transmission oil

Make sure that the final transmission oil is at the specified level. Add oil as necessary. (See page 8-14.)

## Front and rear brakes

### Brake levers

- Check for correct free play in the brake levers. If the free play is incorrect, adjust it. (See pages 8-23 and 8-26.)
- Check operation of the levers. They should move smoothly and there should be a firm feeling when the brakes are applied. If not, have the ATV checked by a Yamaha dealer.

### Brake fluid level

Check the brake fluid level. Add fluid if necessary. (See page 8-25.)

Recommended brake fluid:  
DOT4

### Brake fluid leakage

Check to see if any brake fluid is leaking out of the pipe joint or brake fluid reservoir. Apply the brake firmly for one minute. If there is any leakage, have a Yamaha dealer check the brake system.

## Brake operation

Test the brakes at slow speed after starting out to make sure they are working properly. If the brakes do not provide proper braking performance, check the brakes for wear. (See pages 8-22 and 8-25.)

### **WARNING**

#### **POTENTIAL HAZARD**

Riding with improperly operating brakes.

#### **WHAT CAN HAPPEN**

You could lose braking ability, which could lead to an accident.

#### **HOW TO AVOID THE HAZARD**

Always check the brakes at the start of every ride. Do not ride the ATV if you find any problem with the brakes. If a problem cannot be corrected by the adjustment procedures provided in this manual, have the ATV checked by a Yamaha dealer.

## Throttle lever

Check the operation of the throttle lever. It must open smoothly and spring back to the idle position when released. Have a Yamaha dealer correct if necessary.

## Tires

### **WARNING**

#### **POTENTIAL HAZARD**

Operating this ATV with improper tires, or with improper or uneven tire pressure.

#### **WHAT CAN HAPPEN**

Use of improper tires on this ATV, or operation of this ATV with improper or uneven tire pressure, may cause loss of control, increasing your risk of accident.

#### **HOW TO AVOID THE HAZARD**

- The tires listed below have been approved by Yamaha Motor Co., Ltd. for this model. Other tire combinations are not recommended.

Front:

Manufacturer/model:

MAXXIS/M939

Size:

AT18 x 7-8

Type:

Tubeless

Rear:

Manufacturer/model:

MAXXIS/M940

Size:

AT18 x 9-8

Type:

Tubeless

- The tires should be set to the recommended pressure:

Recommended tire pressure:

Front:

25 kPa (3.6 psi) (0.25 kgf/cm<sup>2</sup>)

Rear:

25 kPa (3.6 psi) (0.25 kgf/cm<sup>2</sup>)

- Check and adjust tire pressures when the tires are cold.
- Tire pressures must be equal on both sides.

- Tire pressure below the minimum specified could cause the tire to dislodge from the rim under severe riding conditions.

Minimum tire pressure:

Front:

22 kPa (3.2 psi) (0.22 kgf/cm<sup>2</sup>)

Rear:

22 kPa (3.2 psi) (0.22 kgf/cm<sup>2</sup>)

- Use no more than the following pressures when seating the tire beads.
- Maximum tire seating pressure:

Front:

250 kPa (36 psi) (2.5 kgf/cm<sup>2</sup>)

Rear:

250 kPa (36 psi) (2.5 kgf/cm<sup>2</sup>)

Higher pressures and fast inflation may cause a tire to burst. Inflate the tires very slowly and carefully.

## Measuring the tire pressure

Use the low-pressure tire gauge.

### TIP

The low-pressure tire gauge is included as standard equipment. Make two measurements of the tire pressure and use the second reading. Dust or

dirt in the gauge could cause the first reading to be incorrect.

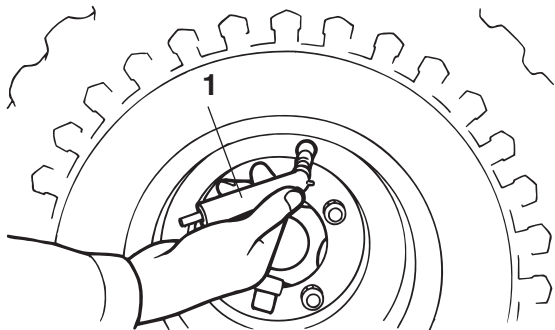

1. Low-pressure tire gauge

Set the tire pressure when the tires are cold. Set the tire pressures to the following specifications:

Recommended pressure:

Front

25 kPa (3.6 psi) (0.25 kgf/cm<sup>2</sup>)

Rear

25 kPa (3.6 psi) (0.25 kgf/cm<sup>2</sup>)

Minimum:

Front

22 kPa (3.2 psi) (0.22 kgf/cm<sup>2</sup>)

Rear

22 kPa (3.2 psi) (0.22 kgf/cm<sup>2</sup>)

### Tire wear limit

Replace the tire when the tire groove decreases to 3 mm (0.12 in).

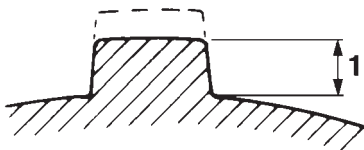

1. Tire wear limit

## Chassis fasteners

Make sure that all nuts, bolts and screws are properly tightened.

## Instruments and switches

Check that all instruments and switches are working properly. Correct if necessary.

# OPERATION

## **WARNING**

A **WARNING** indicates a hazardous situation which, if not avoided, could result in death or serious injury.

## **WARNING**

### **POTENTIAL HAZARD**

Operating ATV without being familiar with all controls.

### **WHAT CAN HAPPEN**

Loss of control, which could cause an accident or injury.

### **HOW TO AVOID THE HAZARD**

Read the Owner's Manual carefully. If there is a control or function you do not understand, ask your Yamaha dealer.

## Starting a cold engine

## **WARNING**

### **POTENTIAL HAZARD**

Frozen control cables in cold weather.

### **WHAT CAN HAPPEN**

You could be unable to control the ATV, which could lead to an accident or collision.

### **HOW TO AVOID THE HAZARD**

When riding in cold weather, always make sure all control cables work smoothly before you begin riding.

## ***NOTICE***

See the "Engine break-in" section on page 6-4 prior to operating the engine for the first time.

1. Set the parking brake.
2. Turn the fuel cock to "ON".
3. Turn the main switch to "ON" and the engine stop switch to "RUN".

## TIP

This model is equipped with an ignition circuit cut-off system. The engine can be started only when the rear brake lever is applied.

4. Use the choke in reference to the figure:

### Position (1):

- Cold engine start with ambient temperature below 30 °C (90 °F).

### Position (2):

- Warming up position.

### Position (3):

- Cold engine start with ambient temperature above 25 °C (80 °F).

## Ambient temp./choke position

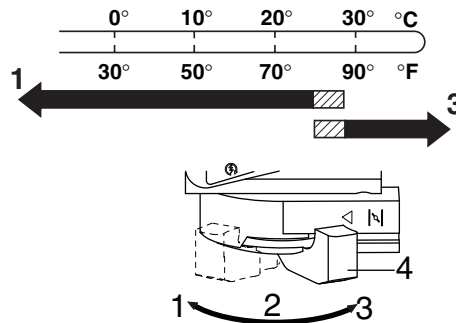

1. Fully open "ON"
2. Half open (warming up position)
3. Closed "OFF"
4. Choke
5. Completely close the throttle lever and start the engine by pushing the start switch.

## TIP

If the engine fails to start, release the start switch, then push it again. Pause a few seconds before the next attempt. Each cranking should be as short as possible to preserve battery energy. Do not

crank the engine more than 10 seconds on each attempt.

6. If the engine is started with the choke in position (1), the choke should be returned to position (2) to warm up the engine. If the engine is started with the choke in position (2), keep the choke in this position to warm up the engine.

## **NOTICE**

**For maximum engine life, always warm the engine up before starting off. Never accelerate hard when the engine is cold!**

7. Continue warming up the engine until it idles smoothly, then return the choke to position (3) before riding.

## **TIP**

The engine is warm when it responds normally to the throttle with the choke turned off.

## **Starting a warm engine**

Follow the same procedure as for starting a cold engine, with the exception that the choke is not required when the engine is warm. Instead, start the engine with the throttle slightly open.

## **To start out and accelerate**

1. Squeeze the front brake lever to release the parking brake.
2. Gradually open the throttle while slowly releasing the rear brake lever.

## **WARNING**

### **POTENTIAL HAZARD**

**Opening the throttle before releasing the parking brake.**

### **WHAT CAN HAPPEN**

**The ATV could wheelie. This would increase the chance of an accident, including overturn.**

### **HOW TO AVOID THE HAZARD**

**Release the parking brake before opening the throttle. Open the throttle gradually.**

## **To decelerate**

When slowing down or stopping, release the throttle and apply the brakes smoothly and evenly. Improper use of the brakes can cause the tires to lose traction, reducing control and increasing the possibility of an accident.



## **NOTICE**

---

**Do not tow the ATV for long distances. The transmission is properly lubricated only when the engine is running. Inadequate lubrication may damage the transmission.**

---

## **Engine break-in**

There is never a more important period in the life of your engine than the first 320 km (200 mi) or 20 hours of riding. For this reason, you should read the following material carefully.

Since the engine is brand new, do not put an excessive load on it for the first 320 km (200 mi) or 20 hours. The various parts in the engine wear and polish themselves to the correct operating clearances. During this period, prolonged full-throttle operation or any condition that might result in engine overheating must be avoided.

### **0–160 km (0–100 mi) or 0–10 hours**

Avoid prolonged operation above 1/2 throttle. Vary the speed of the ATV regularly. Do not operate it at one set throttle position.

### **160–320 km (100–200 mi) or 10–20 hours**

Avoid prolonged operation above 3/4 throttle. Rev the engine freely, but do not use full throttle at any time.

### **320 km (200 mi) or 20 hours and beyond**

The ATV can now be operated normally.

## **NOTICE**

---

**If any engine trouble should occur during the engine break-in period, immediately have a Yamaha dealer check the ATV.**

---

## **Parking**

When parking the ATV, stop the engine, shift the drive select lever into the drive position, apply the parking brake, and then turn the fuel cock to “OFF”.

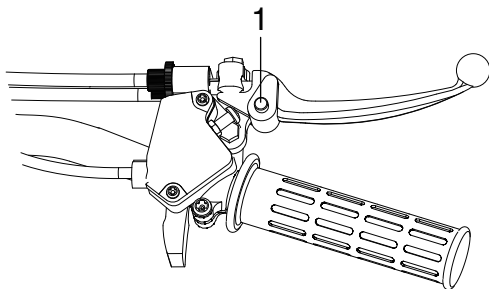

6

1. Parking brake lock button

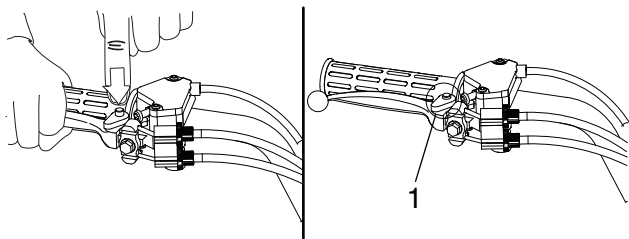

1. Locked position

## Parking on a slope

### **WARNING**

#### **POTENTIAL HAZARD**

Parking on a hill or other incline.

#### **WHAT CAN HAPPEN**

The ATV could roll out of control, increasing the chance of an accident.

#### **HOW TO AVOID THE HAZARD**

Avoid parking on hills or other inclines. If you must park on an incline, place the ATV transversely across the incline, stop the engine, apply the parking brake, and then block the front and rear wheels with rocks or other objects. Do not park the ATV at all on hills that are so steep you could not walk up them easily.

1. Bring the ATV to a stop by applying the brakes in the drive position.
2. Stop the engine.
3. Apply the parking brake.

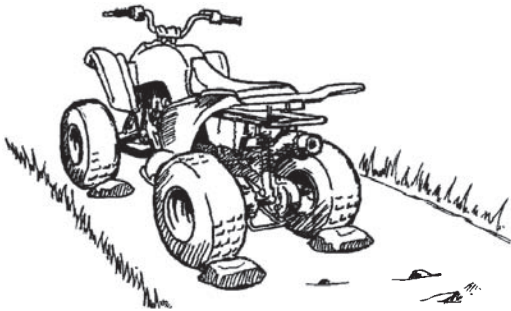

## Accessories and loading

### Accessories

Accessories can affect the handling and control of your ATV. Keep the following in mind when considering an accessory or operating an ATV which has accessories.

- Choose only accessories designed for your ATV. Your Yamaha dealer has a variety of genuine Yamaha accessories. Other accessories may also be available on the market. However, it is not possible for Yamaha to test all non-

Yamaha accessories, nor control over their quality or suitability. Choose a genuine Yamaha accessory, or one that is equivalent in design and quality.

- Accessories should be rigidly and securely mounted. An accessory which can shift position or come off while you are riding could affect your ability to control the ATV.
- Do not mount an accessory where it could interfere with your ability to control the ATV. Examples include (but are not limited to) a heavy or bulky object attached to the handlebars which could make steering difficult, an accessory that limits your ability to move around on the seat, or one that limits your view.
- Use extra caution when riding an ATV with accessories. The ATV may handle differently than it does without accessories.

### Loading

As originally equipped, this ATV is not designed to carry cargo or tow a trailer. If you choose to add accessories so that you can carry cargo or tow a trailer, you must use common sense and good judgment as the stability and handling of an ATV can be changed. When adding accessories, keep

the following points in mind:

- Never exceed the weight limits shown. An overloaded ATV can be unstable.

#### MAXIMUM LOADING LIMIT

ATV loading limit (total weight of rider, cargo, accessories, and tongue):

70.0 kg (154 lb)

- If you are carrying cargo and towing a trailer, include the tongue weight in the maximum ATV load limit.
- Load cargo on the carriers as close to the center of the ATV as possible. Put cargo at the rear of the front carrier, at the front of the rear carrier, and center it.
- Tie down cargo securely to the carriers. Make sure cargo in the trailer cannot move around. A shifting load can cause an accident.
- Make sure the load does not interfere with controls or your ability to see where you are going.
- Ride more slowly than you would without a load. The more weight you carry, the slower you should go.
- Allow more braking distance. A heavier ATV takes longer to stop.
- Avoid making sharp turns unless at very slow

speeds.

- Avoid hills and rough terrain. Choose terrain carefully. Added weight affects the stability and handling of the ATV.

#### **WARNING**

##### **POTENTIAL HAZARD**

**Overloading this ATV or carrying or towing cargo improperly.**

##### **WHAT CAN HAPPEN**

**Could cause changes in ATV handling which could lead to an accident.**

##### **HOW TO AVOID THE HAZARD**

**Never exceed the stated load capacity for this ATV.**

**Cargo should be properly distributed and securely attached.**

**Reduce speed when carrying cargo or pulling a trailer. Allow greater distance for braking.**

#### **WARNING**

**A WARNING indicates a hazardous situation which, if not avoided, could result in death or serious injury.**

# RIDING YOUR ATV



## **WARNING**

**A WARNING indicates a hazardous situation which, if not avoided, could result in death or serious injury.**

### **GETTING TO KNOW YOUR ATV**

This ATV is for recreation use. This section, Riding your ATV, provides general ATV riding instructions for recreational riding. The skills and techniques described in this section, however, are appropriate for all types of riding. Riding your ATV requires special skills acquired through practice over a period of time. Take the time to learn the basic techniques well before attempting more difficult maneuvers.

Riding your new ATV can be a very enjoyable activity, providing you with hours of pleasure. But it is essential to familiarize yourself with the operation of the ATV to achieve the skill necessary to enjoy riding safely. Before you begin to ride, be sure you have read this Owner's Manual completely and understand the operation of the controls. Pay particular attention to the safety information on pages 1-1-1-4. Please also read all notice and warning labels on your ATV.

### **RIDE WITH CARE AND GOOD JUDGEMENT**

**Get training if you are inexperienced.**

Beginners should get training from a certified instructor.

Become familiar with this ATV at slow speeds first, even if you are an experienced operator. Do not attempt to operate at maximum performance until you are totally familiar with the ATV's handling and performance characteristics.

**⚠ WARNING**

**POTENTIAL HAZARD**

Operating this ATV without proper instruction.

**WHAT CAN HAPPEN**

The risk of an accident is greatly increased if the operator does not know how to operate the ATV properly in different situations and on different types of terrain.

**HOW TO AVOID THE HAZARD**

Beginning and inexperienced operators should complete the certified training course offered by Yamaha. They should then regularly practice the skills learned in the course and the operating techniques described in this Owner's Manual. For more information about the training course, contact an authorized ATV dealer or call 1-800-887-2887.

Riding your ATV requires skills acquired through practice over a period of time.

Take the time to learn the basic techniques well before attempting more difficult maneuvers.

Not recommended for children under 12 years of age.

**⚠ WARNING**

**POTENTIAL HAZARD**

Failure to follow the age recommendations for this ATV.

**WHAT CAN HAPPEN**

Use by children of ATVs that are not recommended for their age can lead to severe injury or death of the child.

**HOW TO AVOID THE HAZARD**

A child under 12 should never operate an ATV with engine size greater than 70 cc.



This ATV is designed to carry operator only – passengers prohibited.

**⚠ WARNING**

**POTENTIAL HAZARD**

Carrying a passenger on this ATV.

**WHAT CAN HAPPEN**

Greatly reduces your ability to balance and control this ATV. Could cause an accident, resulting in harm to you and/or your passenger.

**HOW TO AVOID THE HAZARD**

Never carry a passenger. The long seat is to allow the operator to shift position as needed during operation. It is not for carrying passengers.





### **WARNING**

#### POTENTIAL HAZARD

Operating this ATV without wearing an approved motorcycle helmet, eye protection and protective clothing.

#### WHAT CAN HAPPEN

Operating without an approved motorcycle helmet increases your chances of a severe head injury or death in the event of an accident.

Operating without eye protection can result in an accident and increases your chances of a severe injury in the event of an accident.

Operating without protective clothing increases your chances of severe injury in the event of an accident.

#### HOW TO AVOID THE HAZARD

Always wear an approved motorcycle helmet that fits properly.

You should also wear:

- eye protection (goggles or face shield)
- gloves
- boots
- long-sleeved shirt or jacket
- long pants

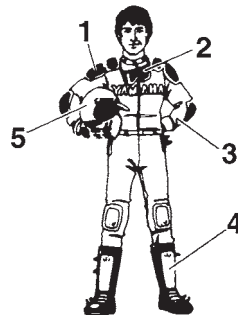

1. Protective clothing
2. Goggles
3. Gloves
4. Boots
5. Helmet

**Do not operate after consuming alcohol or drugs.**

The operator's performance capability is reduced by the influence of alcohol or drugs.



**⚠ WARNING**

**POTENTIAL HAZARD**

Operating this ATV after consuming alcohol or drugs.

**WHAT CAN HAPPEN**

- Could seriously affect your judgment.
- Could cause you to react more slowly.
- Could affect your balance and perception.
- Could result in an accident.

**HOW TO AVOID THE HAZARD**

**Never consume alcohol or drugs before or while driving this ATV.**

**Pre-operation checks**

Always perform the pre-operation checks listed on page 5-1 before riding for proper care of the ATV and to ensure safety.

**⚠ WARNING**

**POTENTIAL HAZARD**

Failure to inspect the ATV before operating.  
Failure to properly maintain the ATV.

**WHAT CAN HAPPEN**

Increases the possibility of an accident or equipment damage.

**HOW TO AVOID THE HAZARD**

Always inspect your ATV each time you use it to make sure the ATV is in safe operating condition.

Always follow the inspection and maintenance procedures and schedules described in the Owner's Manual.

**⚠ WARNING**

**POTENTIAL HAZARD**

Operating this ATV with improper tires, or with improper or uneven tire pressure.

**WHAT CAN HAPPEN**

Use of improper tires on this ATV, or operation of this ATV with improper or uneven tire pressure, may cause loss of control, increasing your risk of an accident.

**HOW TO AVOID THE HAZARD**

Always use the size and type tires specified in the Owner's Manual for this ATV on page 5-4.

Always maintain proper tire pressure as described in the Owner's Manual on page 5-5.

**⚠ WARNING**

**A WARNING indicates a hazardous situation which, if not avoided, could result in death or serious injury.**

**Do not operate at speeds too fast for your skills or the conditions.**

**⚠ WARNING**

**POTENTIAL HAZARD**

Operating this ATV at speeds too fast for your skills or the conditions.

**WHAT CAN HAPPEN**

Increases your chances of losing control of the ATV, which can result in an accident.

**HOW TO AVOID THE HAZARD**

Always go at a speed that is proper for the terrain, visibility and operating conditions, and your experience.

**Speed limiters**

For riders less experienced with this model, the throttle lever housing is equipped with a vehicle speed limiter. This speed limiter keeps the throttle from fully opening, even when the throttle lever is pushed to the maximum. Turning in the adjusting screw limits the maximum engine power available and decreases the maximum speed of the ATV. Turning in the adjusting screw decreases top speed, and turning it out increases top speed. (See pages 4-3 and 4-4.)

This model also has an engine speed limiter plate to limit the amount of engine power available. Yamaha recommends that all beginning riders start off with the vehicle speed limiter turned in and the

7 engine speed limiter plate installed to limit the amount of speed available while they learn. The vehicle speed limiter may be gradually adjusted to increase maximum speed as the beginner becomes more familiar with operating the ATV. Parents should decide when to adjust the ATV for more power as their youngster's riding skills improve. Once the ATV rider can operate with skill at the top speed permitted by adjusting the vehicle speed limiter alone, the engine speed limiter plate can be removed. Since removal of this plate will result in a significant increase in power, turn the vehicle speed limiter adjusting screw back in again; adjust it out in stages as you did before. For engine speed limiter plate removal instructions, see page 4-4.

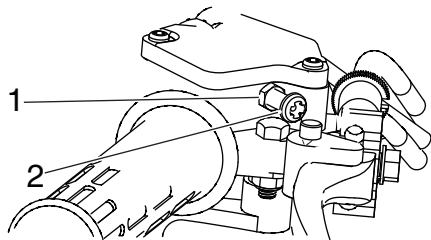

1. Locknut

2. Adjusting screw

## Loading and accessories

Use extra caution when riding the ATV with additional loads, such as accessories or cargo. The ATV's handling may be adversely affected. Reduce your speed when adding additional loads.

### MAXIMUM LOADING LIMIT

ATV loading limit (total weight of cargo, rider, accessories, and tongue):

70.0 kg (154 lb)

## WARNING

### POTENTIAL HAZARD

**Overloading this ATV or carrying or towing cargo improperly.**

### WHAT CAN HAPPEN

**Could cause changes in ATV handling which could lead to an accident.**

### HOW TO AVOID THE HAZARD

**Never exceed the stated load capacity for this ATV.**

Cargo should be properly distributed and securely attached.

Reduce speed when carrying cargo or pulling a trailer. Allow greater distance for braking.

Always follow the instructions in your Owner's Manual for carrying cargo or pulling a trailer.

### **During operation**

Always keep your feet on the footboards during operation, otherwise they may contact the rear wheels.

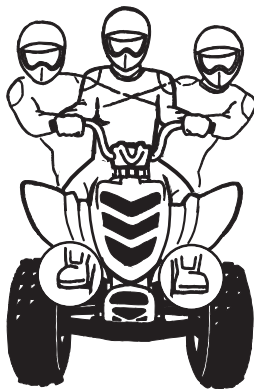

## **⚠ WARNING**

### **POTENTIAL HAZARD**

Removing hands from handlebars or feet from footboards during operation.

### **WHAT CAN HAPPEN**

Removing even one hand or foot can reduce your ability to control the ATV or could cause you to lose your balance and fall off of the ATV. If you remove a foot from a footboard, your foot or leg may come into contact with the rear wheels, which could injure you or cause an accident.

### **HOW TO AVOID THE HAZARD**

Always keep both hands on the handlebars and both feet on the footboards of your ATV during operation.

Avoid wheelies and jumping. You may lose control of the ATV or overturn.

## **⚠ WARNING**

### **POTENTIAL HAZARD**

Attempting wheelies, jumps, and other stunts.

### **WHAT CAN HAPPEN**

Increases the chance of an accident, including an overturn.

### **HOW TO AVOID THE HAZARD**

Never attempt stunts, such as wheelies or jumps. Don't try to show off.

## **Modifications**

## **⚠ WARNING**

### **POTENTIAL HAZARD**

Operating this ATV with improper modifications.

### **WHAT CAN HAPPEN**

Improper installation of accessories or modification of this ATV may cause changes in handling which in some situations could lead to an accident.

### **HOW TO AVOID THE HAZARD**

Never modify this ATV through improper installation or use of accessories. All parts and accessories added to this ATV should be genuine Yamaha or equivalent components designed for use on this ATV and should be installed and used according to instructions. If you have questions, consult an authorized ATV dealer.

## **Exhaust system**

The exhaust system on the ATV is very hot during and following operation. To prevent burns, avoid touching the exhaust system. Park the ATV in a place where pedestrians or children are not likely to touch it.

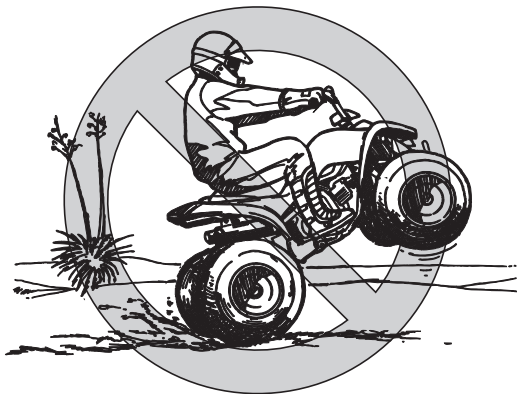

**⚠ WARNING**

**POTENTIAL HAZARD**

Hot exhaust system.

**WHAT CAN HAPPEN**

Dry grass or brush or other combustible material accumulated around the engine area could catch fire.

Someone touching the exhaust system during or after operation could be burned.

**HOW TO AVOID THE HAZARD**

Do not operate, idle, or park the ATV in dry grass or other dry ground cover.

Keep the engine area free of dry grass, brush, or other combustible material.

Do not touch the hot exhaust system.

Do not park the ATV in a place where others might be likely to touch it.

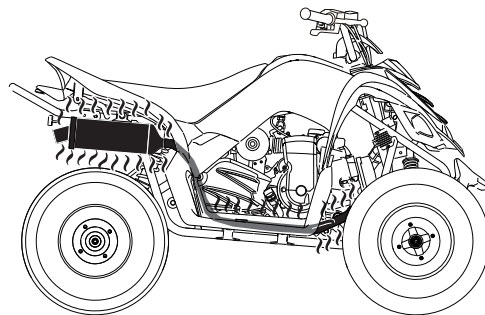

**BE CAREFUL WHERE YOU RIDE**

This ATV is designed for off-road use only. Riding on paved surfaces can cause loss of control.

7

**⚠ WARNING**

**POTENTIAL HAZARD**

Operating this ATV on paved surfaces.

**WHAT CAN HAPPEN**

ATVs are designed for off-road use only. Paved surfaces may seriously affect handling and control of the ATV, and may cause the ATV to go out of control.

### **HOW TO AVOID THE HAZARD**

**Always avoid paved surfaces, including sidewalks, driveways, parking lots and streets.**

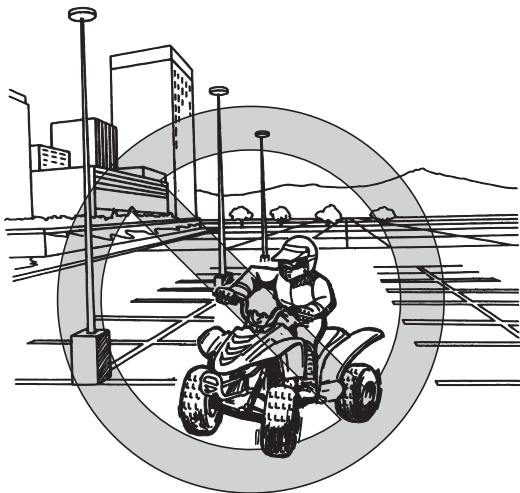

Do not ride on any public road, street, or highway. Riding on public roads can result in collisions with other vehicles.

### **⚠ WARNING**

#### **POTENTIAL HAZARD**

**Operating this ATV on public streets, roads or highways.**

#### **WHAT CAN HAPPEN**

**You can collide with another vehicle.**

#### **HOW TO AVOID THE HAZARD**

**Never operate this ATV on any public street, road or highway, even a dirt or gravel one. In many states it is illegal to operate ATVs on public streets, roads and highways.**

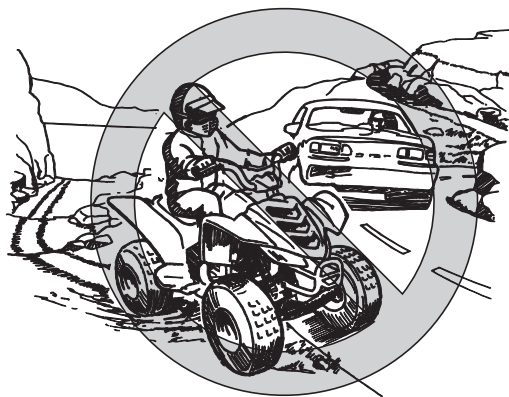



Know the terrain where you ride. Ride cautiously in unfamiliar areas. Stay alert for **holes, rocks, or roots** in the terrain, and **other hidden hazards** which may cause the ATV to upset.

**⚠ WARNING**

**POTENTIAL HAZARD**

Failure to use extra care when operating this ATV on unfamiliar terrain.

**WHAT CAN HAPPEN**

You can come upon hidden rocks, bumps, or holes, without enough time to react. Could result in the ATV overturning or going out of control.

**HOW TO AVOID THE HAZARD**

Go slowly and be extra careful when operating on unfamiliar terrain. Always be alert to changing terrain conditions when operating the ATV.

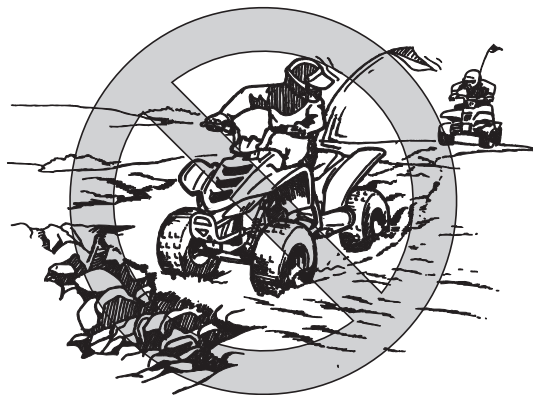

**⚠ WARNING**

**POTENTIAL HAZARD**

Failure to use extra care when operating on excessively rough, slippery or loose terrain.

**WHAT CAN HAPPEN**

Could cause loss of traction or ATV control, which could result in an accident, including an overturn.

## **HOW TO AVOID THE HAZARD**

Do not operate on excessively rough, slippery or loose terrain until you have learned and practiced the skills necessary to control the ATV on such terrain. Always be especially cautious on these kinds of terrain.

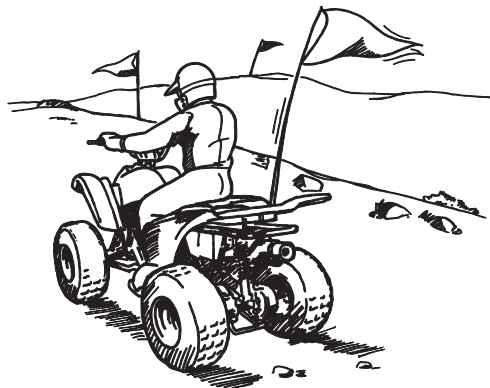

7

When riding in an area where you might not easily be seen, such as desert terrain, mount a caution flag on the ATV. **DO NOT** use the flag pole bracket as a trailer hitch.

## **⚠ WARNING**

### **POTENTIAL HAZARD**

Operating in areas where you might not be seen by other off-road vehicles.

### **WHAT CAN HAPPEN**

You could be in a collision. You could be injured.

### **HOW TO AVOID THE HAZARD**

Always mount a caution flag on the ATV to make you more visible. Watch carefully for other vehicles.

Do not ride in areas posted “no trespassing”.  
Do not ride on private property without getting permission.

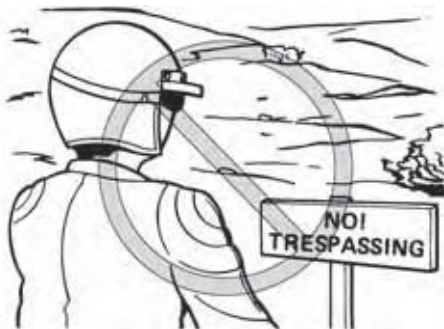

Select a large, flat area off-road to become familiar with your ATV. Make sure that this area is free of obstacles and other riders. You should practice control of the throttle, brakes, and turning techniques in this area before trying more difficult terrain. Always avoid riding on paved surfaces: the ATV is designed for off-road use only, and handling maneuvers are more difficult to perform on pavement.

Set the parking brake and follow the instruction on page 6-1 to start the engine. Once it has warmed up you are ready to begin riding your ATV. Re-

member that the engine and exhaust pipe will be hot when riding and afterwards; do not allow skin or clothing to come in contact with these components.

With the engine idling, release the parking brake. Apply the throttle slowly and smoothly. You will start to accelerate. If the throttle is applied too abruptly, the front wheels may lift off the ground, resulting in a loss of directional control. Avoid higher speeds until you are thoroughly familiar with the operation of your ATV.

When slowing down or stopping, release the throttle and apply the brakes smoothly and evenly. Improper use of the brakes can cause the tires to lose traction, reducing control and increasing the possibility of an accident.

## TURNING YOUR ATV

To achieve maximum traction while riding off-road, the two rear wheels are mounted solidly on one axle and turn together at the same speed. Therefore, unless the wheel on the inside of the turn is allowed to slip or lose some traction, the ATV will resist turning. A special turning technique must be used to allow the ATV to make turns quickly and easily. It is essential that this skill be learned first at

low speed.

**⚠ WARNING**

**POTENTIAL HAZARD**

**Turning improperly.**

**WHAT CAN HAPPEN**

The ATV could go out of control, causing a collision or overturn.

**HOW TO AVOID THE HAZARD**

Always follow proper procedures for turning as described in this Owner's Manual. Practice turning at low speeds before attempting to turn at faster speeds. Do not turn at speeds too fast for your skills or the conditions.



1. Lean towards inside of turn.
2. Support your weight on the outer footboard.

As you approach a curve, slow down and begin to turn the handlebars in the desired direction. As you do so, put your weight on the footboard to the outside of the turn (opposite your desired direction) and lean your upper body into the turn. Use the throttle to maintain an even speed through the turn. This maneuver will let the wheel on the inside of the turn slip slightly, allowing the ATV to make the turn properly.

This procedure should be practiced at slow speed many times in a large off-road area with no obstacles. If an incorrect technique is used, your ATV may continue to go straight. If the ATV doesn't turn, come to a stop and then practice the procedure again. If the riding surface is slippery or loose, it may help to position more of your weight over the front wheels by moving forward on the seat. Once you have learned this technique, you should be able to perform it at higher speeds or in tighter

curves.

Improper riding procedures such as abrupt throttle changes, excessive braking, incorrect body movements, or too much speed for the sharpness of the turn may cause the ATV to tip. If the ATV begins to tip over to the outside while negotiating a turn, lean more to the inside. It may also be necessary to gradually let off on the throttle and steer to the outside of the turn to avoid tipping over.

Remember: Avoid higher speeds until you are thoroughly familiar with the operation of your ATV.

### **CLIMBING UPHILL**

Use proper riding techniques to avoid ATV over- turns on hills. Be sure that you can maneuver your ATV well on flat ground before attempting any incline and then practice riding first on gentle slopes. Try more difficult climbs only after you have developed your skill. In all cases avoid inclines with slippery or loose surfaces, or obstacles that might cause you to lose control.

#### **WARNING**

##### **POTENTIAL HAZARD**

**Operating on excessively steep hills.**

#### **WHAT CAN HAPPEN**

**The ATV can overturn more easily on extremely steep hills than on level surfaces or small hills.**

#### **HOW TO AVOID THE HAZARD**

**Never operate the ATV on hills too steep for the ATV or for your abilities. Practice on smaller hills before attempting large hills.**

It is important when climbing a hill to make sure that your weight is transferred forward on the ATV. This can be accomplished by leaning forward and, on steeper inclines, standing on the footboards and leaning forward over the handlebars.

#### **WARNING**

##### **POTENTIAL HAZARD**

**Climbing hills improperly.**

#### **WHAT CAN HAPPEN**

**Could cause loss of control or cause the ATV to overturn.**

### **HOW TO AVOID THE HAZARD**

**Always follow proper procedures for climbing hills as described in this Owner's Manual. Always check the terrain carefully before you start up any hill.**

**Never climb hills with excessively slippery or loose surfaces.**

**Shift your weight forward.**

**Never open the throttle suddenly. The ATV could flip over backwards.**

**Never go over the top of any hill at high speed. An obstacle, a sharp drop, or another vehicle or person could be on the other side of the hill.**

7

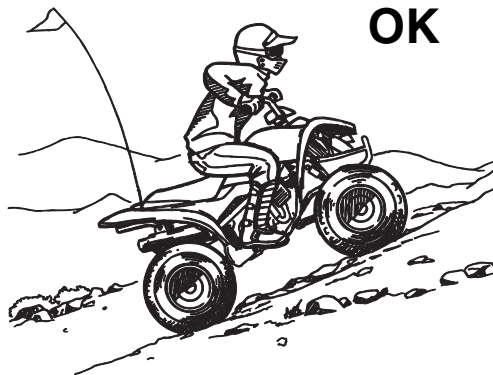

If you are climbing a hill and you find that you have not properly judged your ability to make it to the top, you should turn the ATV around while you still have forward motion (provided you have the room to do so) and go down the hill.

## **! WARNING**

### **POTENTIAL HAZARD**

**Improperly crossing hills or turning on hills.**

### **WHAT CAN HAPPEN**

**Could cause loss of control or cause the ATV to overturn.**

### **HOW TO AVOID THE HAZARD**

**Never attempt to turn the ATV around on any hill until you have mastered the turning technique as described in the Owner's Manual on level ground. Be very careful when turning on any hill.**

**Avoid crossing the side of a steep hill if possible.**

### **When crossing the side of a hill:**

**Always follow proper procedures as described in the Owner's Manual.**

**Avoid hills with excessively slippery or loose surfaces.**

**Shift your weight to the uphill side of the ATV.**

**OK**

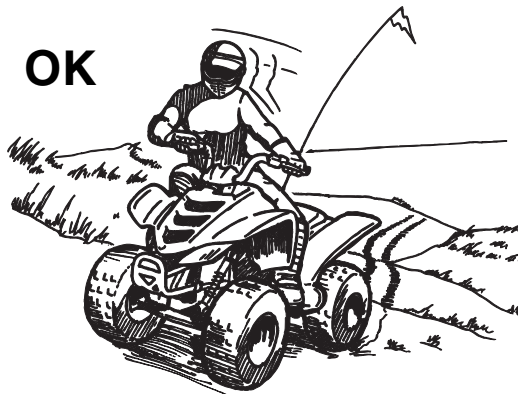

If your ATV has stalled or stopped and you believe you can continue up the hill, restart carefully to make sure you do not lift the front wheels which could cause you to lose control. If you are unable to continue up the hill, dismount the ATV on the uphill side. Physically turn the ATV around and then descend the hill.

If you start to roll backwards, **DO NOT** apply the rear brake to stop or try to put the ATV in gear. The ATV could easily tip over backwards. Instead, apply the front brake gradually, or dismount the ATV immediately on the uphill side.

## WARNING

### **POTENTIAL HAZARD**

Stalling, rolling backwards or improperly dismounting while climbing a hill.

### **WHAT CAN HAPPEN**

Could result in the ATV overturning.

### **HOW TO AVOID THE HAZARD**

Maintain a steady speed when climbing a hill.

#### **If you lose all forward speed:**

- Keep weight uphill.
- Apply the brakes.
- Lock the parking brake after you are stopped.

#### **If you begin rolling backwards:**

- Keep weight uphill.
- Never apply the rear brake while rolling backwards.
- Apply the front brake.
- When fully stopped, apply the rear brake as well, and then lock the parking brake.

Dismount on uphill side or to a side if pointed straight uphill. Turn the ATV around and re-mount, following the procedure described in the Owner's Manual.

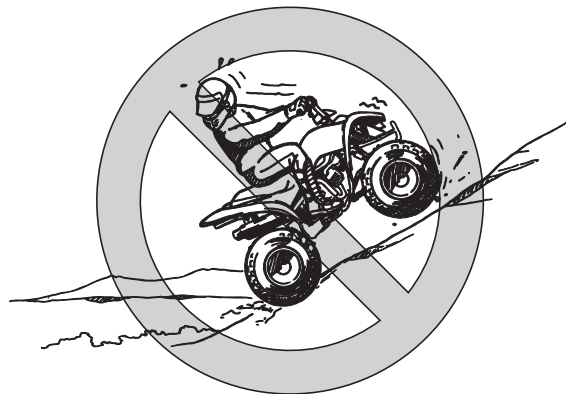

### **RIDING DOWNHILL**

When riding your ATV downhill, shift your weight as far to the rear and uphill side of the ATV as possible. Move back on the seat and sit with your arms straight. Allow the engine compression to do most of the braking for you. Improper braking may cause a loss of traction.

Use caution while descending a hill with loose or slippery surfaces. Braking ability and traction may be adversely affected by these surfaces. Improper braking may also cause a loss of traction.

Whenever possible, ride your ATV straight down-



hill. Avoid sharp angles which could allow the ATV to tip or roll over. Carefully choose your path and ride no faster than you will be able to react to obstacles which may appear.

## **⚠ WARNING**

### **POTENTIAL HAZARD**

**Going down a hill improperly.**

### **WHAT CAN HAPPEN**

**Could cause loss of control or cause the ATV to overturn.**

### **HOW TO AVOID THE HAZARD**

**Always follow proper procedures for going down hills as described in this Owner's Manual.**

**TIP: a special technique is required when braking as you go down a hill.**

**Always check the terrain carefully before you start down any hill.**

**Shift your weight backward.**

**Never go down a hill at high speed.**

**Avoid going down a hill at an angle that would cause the ATV to lean sharply to one side. Go straight down the hill where possible.**

**OK**

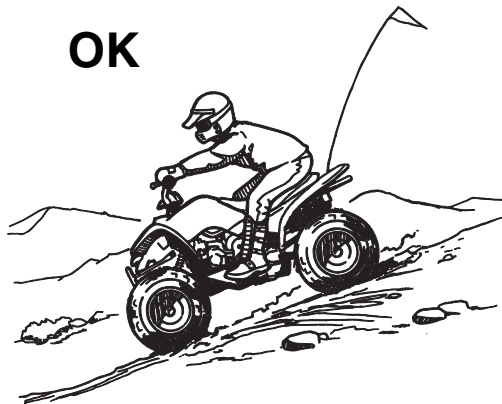

## **CROSSING A SLOPE**

Traversing a sloping surface on your ATV requires you to properly position your weight to maintain proper balance. Be sure that you have learned the basic riding skills on flat ground before attempting to cross a sloping surface. Avoid slopes with slippery surfaces or rough terrain that may upset your balance.

As you travel across a slope, lean your body in the uphill direction. It may be necessary to correct the steering when riding on loose surfaces by pointing the front wheels slightly uphill. When riding on

slopes, be sure not to make sharp turns either up or down hill.

If your ATV does begin to tip over, gradually steer in the downhill direction if there are no obstacles in your path. As you regain proper balance, gradually steer again in the direction you wish to travel.

## **WARNING**

### **POTENTIAL HAZARD**

**Improperly crossing hills or turning on hills.**

### **WHAT CAN HAPPEN**

**Could cause loss of control or cause the ATV to overturn.**

### **HOW TO AVOID THE HAZARD**

**Never attempt to turn the ATV around on any hill until you have mastered the turning technique as described in the Owner's Manual on level ground. Be very careful when turning on any hill. Avoid crossing the side of a steep hill if possible.**

### **When crossing the side of a hill:**

**Always follow proper procedures as described in the Owner's Manual.**

**Avoid hills with excessively slippery or loose surfaces.**

**Shift your weight to the uphill side of the ATV.**



### **CROSSING THROUGH SHALLOW WATER**

The ATV can be used to cross slow moving, shallow water of up to a maximum of 20 cm (8 in) in depth. Before entering the water, choose your path

carefully. Enter where there is no sharp drop off, and avoid rocks or other obstacles which may be slippery or upset the ATV. Drive slowly and carefully.

## **⚠ WARNING**

### **POTENTIAL HAZARD**

**Operating this ATV through deep or fast flowing water.**

### **WHAT CAN HAPPEN**

**Tires may float, causing loss of traction and loss of control, which could lead to an accident.**

### **HOW TO AVOID THE HAZARD**

**Never operate this ATV in fast flowing water or in water deeper than that specified in your Owner's Manual.**

**Remember that wet brakes may have reduced stopping ability. Test your brakes after leaving water. If necessary, apply them several times to let friction dry out the linings.**



Test your brakes after leaving the water. Do not continue to ride your ATV without verifying that you have regained proper braking ability.

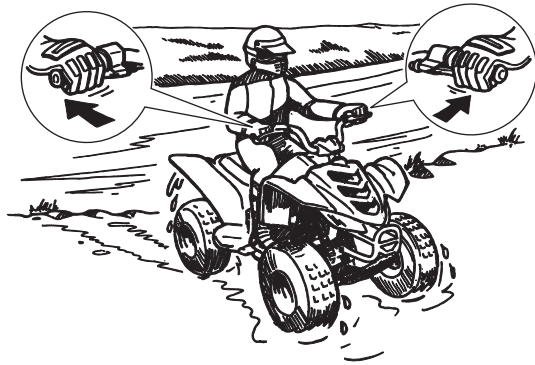

7

## NOTICE

After riding your ATV in water, be sure to drain the trapped water by removing the check hose at the bottom of the air filter case. Wash the ATV in fresh water if it has been operated in salt water or muddy conditions.

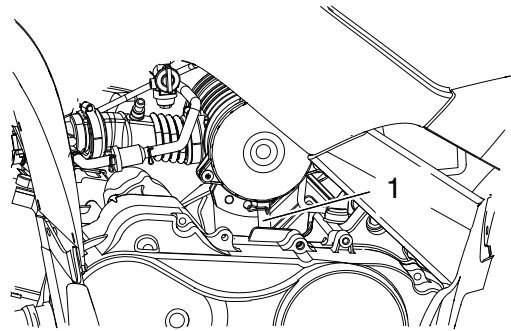

1. Air filter case check hose

## RIDING OVER ROUGH TERRAIN

Riding over rough terrain should be done with caution. Look out for obstacles which could cause damage to the ATV or could lead to an upset or accident. Be sure to keep your feet firmly mounted on the footboards at all times. Avoid jumping the ATV as loss of control and damage to the ATV may result.

## **⚠ WARNING**

### **POTENTIAL HAZARD**

**Improperly operating over obstacles.**

### **WHAT CAN HAPPEN**

**Could cause loss of control or a collision.**

**Could cause the ATV to overturn.**

### **HOW TO AVOID THE HAZARD**

**Before operating in a new area, check for obstacles.**

**Never attempt to ride over large obstacles, such as large rocks or fallen trees. When you go over obstacles, always follow proper procedures as described in the Owner's Manual.**



If the rear wheels of your ATV start to slide sideways, control can usually be regained (if there is room to do so) by steering in the direction of the slide. Applying the brakes or accelerating is not recommended until you have corrected the slide.

## **SLIDING AND SKIDDING**

Care should be used when riding on loose or slippery surfaces since the ATV may slide. If unexpected and uncorrected, sliding could lead to an accident.

To reduce the tendency for the front wheels to slide in loose or slippery conditions, positioning your weight over the front wheels will sometimes help.



7

With practice, over a period of time, skill at controlled sliding can be developed. The terrain should be chosen carefully before attempting such maneuvers, since both stability and control are reduced. Bear in mind that sliding maneuvers should always be avoided on extremely slippery surfaces such as ice, since all control may be lost.

### **WARNING**

#### **POTENTIAL HAZARD**

**Skidding or sliding improperly.**

#### **WHAT CAN HAPPEN**

You may lose control of this ATV. You may also regain traction unexpectedly, which may cause the ATV to overturn.

#### **HOW TO AVOID THE HAZARD**

Learn to safely control skidding or sliding by practicing at low speeds and on level, smooth terrain.

On extremely slippery surfaces, such as ice, go slowly and be very cautious in order to reduce the chance of skidding or sliding out of control.

#### **WHAT TO DO IF...**

This section is designed to be a reference guide only. Be sure to read each section on riding techniques completely.

#### **WHAT TO DO...**

- If your ATV doesn't turn when you want it to:  
Bring the ATV to a stop and practice the turning maneuvers again. Be sure you are putting your weight on the footboard to the outside of the turn. Position your weight over the front wheels for better control. (See page 7-15.)
- If your ATV begins to tip while turning:

Lean more into the turn to regain balance. If necessary, gradually let off the throttle and/or steer to the outside of the turn. (See page 7-15.)

- If your ATV starts to slide sideways:  
Steer in the direction of the slide if you have the room. Applying the brakes or accelerating is not recommended until you have corrected the slide. (See page 7-25.)
- If your ATV can't make it up a hill you are trying to climb:  
Turn the ATV around if you still have forward speed. If not, stop, dismount on the uphill side of the ATV and physically turn the ATV around. If the ATV starts to slip backwards, DO NOT USE THE REAR BRAKE – the ATV may tip over on top of you. Instead, apply the front brake or dismount the ATV on the uphill side. (See page 7-17.)
- If your ATV is traversing a sloping surface:  
Be sure to ride with your weight positioned towards the uphill side of the ATV to maintain proper balance. If the ATV starts to tip, steer down the hill (if there are no obstacles in your way) to regain balance. If you discover that the ATV is going to tip over, dismount on the uphill side. (See page 7-21.)

- If your ATV encounters shallow water:  
Ride slowly and carefully through slow moving water, watching for obstacles. Be sure to let water drain from the ATV and CHECK YOUR BRAKES FOR PROPER OPERATION when you come out of the water. Do not continue to ride your ATV until you have regained adequate braking ability. (See page 7-22.)

### **WARNING**

**A WARNING indicates a hazardous situation which, if not avoided, could result in death or serious injury.**

# PERIODIC MAINTENANCE AND MINOR REPAIR

Safety is an obligation of the owner. Periodic inspection, adjustment and lubrication will keep your ATV in the safest and best operating condition possible. The most important points of inspection, adjustment, and lubrication are explained on the following pages.

The intervals given in the periodic maintenance and lubrication chart should be considered as a general guide under normal riding conditions. However, **DEPENDING ON THE WEATHER, TERRAIN, GEOGRAPHICAL LOCATION, AND INDIVIDUAL USE, THE MAINTENANCE INTERVALS MAY NEED TO BE SHORTENED.**

## **WARNING**

### **POTENTIAL HAZARD**

**Servicing an engine while it is running.**

### **WHAT CAN HAPPEN**

**Moving parts can catch clothing or parts of the body, causing injury.**

**Electrical components can cause shocks or start fires.**

### **HOW TO AVOID THE HAZARD**

**Turn off the engine when performing maintenance unless otherwise specified. Have a Yamaha dealer perform the service if you are not familiar with maintenance work.**

### **Owner's manual and tool kit**

Be sure to put this owner's manual in the plastic bag and to always carry it as well as the owner's tool kit and the low-pressure tire gauge in their respective compartments under the seat.



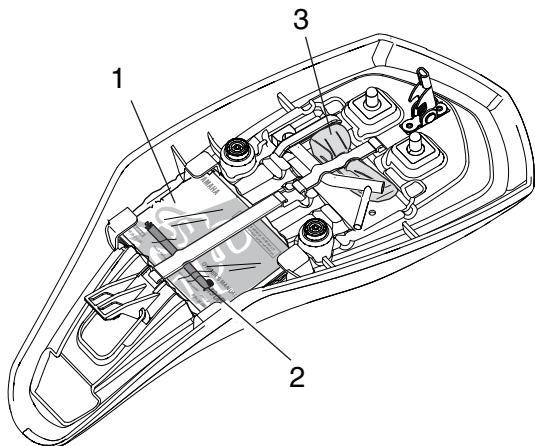

1. Owner's manual
2. Low-pressure tire gauge
3. Owner's tool kit

The service information included in this manual and the tools provided in the owner's tool kit are intended to assist you in the performance of preventive maintenance and minor repairs. However, additional tools such as a torque wrench may be necessary to perform certain maintenance work correctly.

## TIP

If you do not have the tools or experience required for a particular job, have a Yamaha dealer perform it for you.

## WARNING

### POTENTIAL HAZARD

**Operating this ATV with improper modifications.**

### WHAT CAN HAPPEN

**Improper installation of accessories or modification of this ATV may cause changes in handling which in some situations could lead to an accident.**

### HOW TO AVOID THE HAZARD

**Never modify this ATV through improper installation or use of accessories. All parts and accessories added to this ATV should be genuine Yamaha or equivalent components designed for use on this ATV and should be installed and used according to instructions. If you have questions, consult an authorized Yamaha ATV dealer.**

## Periodic maintenance chart for the emission control system

### TIP

- For ATVs not equipped with an odometer or an hour meter, follow the month maintenance intervals.
- For ATVs equipped with an odometer or an hour meter, follow the km (mi) or hours maintenance intervals. However, keep in mind that if the ATV isn't used for a long period of time, the month maintenance intervals should be followed.
- Items marked with an asterisk should be performed by a Yamaha dealer as they require special tools, data and technical skills.

NO.	ITEM	CHECK OR MAINTENANCE JOB	Whichever comes first ⇒	INITIAL			EVERY		
				month	1	3	6	6	12
				km (mi)	320 (200)	1300 (800)	2500 (1600)	2500 (1600)	5000 (3200)
hours	20	80	160	160	320				
1	* Fuel line	• Check fuel hoses for cracks or other damage, and replace if necessary.				√	√	√	
2	Spark plug	• Check condition and clean, regap, or replace if necessary.	√	√	√	√	√	√	
3	* Valves	• Check valve clearance and adjust if necessary.	√		√	√	√	√	
4	* Carburetor	• Check choke operation and correct if necessary. • Check engine idling speed and adjust if necessary.		√	√	√	√	√	
5	* Crankcase breather system	• Check breather hose for cracks or other damage, and replace if necessary.			√	√	√	√	

NO.	ITEM	CHECK OR MAINTENANCE JOB	Whichever comes first ⇒	INITIAL			EVERY		
				month	1	3	6	6	12
				km (mi)	320 (200)	1300 (800)	2500 (1600)	2500 (1600)	5000 (3200)
				hours	20	80	160	160	320
6	*	<b>Exhaust system</b>	<ul style="list-style-type: none"> <li>• Check for leakage and replace gasket(s) if necessary.</li> <li>• Check for looseness and tighten all screw clamps and joints if necessary.</li> </ul>			√	√	√	
7		<b>Spark arrester</b>	<ul style="list-style-type: none"> <li>• Clean.</li> </ul>			√	√	√	

## General maintenance and lubrication chart

NO.	ITEM	CHECK OR MAINTENANCE JOB	Whichever comes first ⇒	INITIAL			EVERY		
				month	1	3	6	6	12
				km (mi)	320 (200)	1300 (800)	2500 (1600)	2500 (1600)	5000 (3200)
hours	20	80	160	160	320				
1	* Timing chain	<ul style="list-style-type: none"> <li>• Check chain tension.</li> <li>• Adjust if necessary.</li> </ul>		√		√	√	√	
2	Air filter element	<ul style="list-style-type: none"> <li>• Clean and replace if necessary.</li> </ul>		Every 20–40 hours (more often in wet or dusty areas)					
3	* Clutch	<ul style="list-style-type: none"> <li>• Check operation.</li> </ul>		√		√	√	√	
4	* Front brake	<ul style="list-style-type: none"> <li>• Check operation and correct if necessary.</li> <li>• Check brake lever free play and adjust if necessary.</li> </ul>		√	√	√	√	√	
		<ul style="list-style-type: none"> <li>• Replace brake shoes.</li> </ul>		Whenever worn to the limit					
5	* Rear brake	<ul style="list-style-type: none"> <li>• Check operation and correct if necessary.</li> <li>• Check fluid level and ATV for fluid leakage, and correct if necessary.</li> </ul>		√	√	√	√	√	
		<ul style="list-style-type: none"> <li>• Replace brake pads.</li> </ul>		Whenever worn to the limit					
6	* Brake hoses	<ul style="list-style-type: none"> <li>• Check for cracks or other damage, and replace if necessary.</li> </ul>			√	√	√	√	
		<ul style="list-style-type: none"> <li>• Replace.</li> </ul>		Every 4 years					
7	* Wheels	<ul style="list-style-type: none"> <li>• Check runout and for damage, and replace if necessary.</li> </ul>		√		√	√	√	
8	* Tires	<ul style="list-style-type: none"> <li>• Check tread depth and for damage, and replace if necessary.</li> <li>• Check air pressure and balance, and correct if necessary.</li> </ul>		√		√	√	√	

NO.	ITEM	CHECK OR MAINTENANCE JOB	Whichever comes first ⇒	INITIAL			EVERY		
				month	1	3	6	6	12
				km (mi)	320 (200)	1300 (800)	2500 (1600)	2500 (1600)	5000 (3200)
hours	20	80	160	160	320				
9	* Wheel hub bearings	<ul style="list-style-type: none"> <li>Check for looseness or damage, and replace if necessary.</li> </ul>		√		√	√	√	
10	* Chassis fasteners	<ul style="list-style-type: none"> <li>Make sure that all nuts, bolts, and screws are properly tightened.</li> </ul>		√	√	√	√	√	
11	* Shock absorber assemblies	<ul style="list-style-type: none"> <li>Check operation and correct if necessary.</li> <li>Check for oil leakage and replace if necessary.</li> </ul>				√	√	√	
12	* Front knuckle pivots	<ul style="list-style-type: none"> <li>Lubricate with lithium-soap-based grease.</li> </ul>				√	√	√	
13	* Steering shaft	<ul style="list-style-type: none"> <li>Lubricate with lithium-soap-based grease.</li> </ul>				√	√	√	
14	* Steering system	<ul style="list-style-type: none"> <li>Check operation and repair or replace if damaged.</li> <li>Check toe-in and adjust if necessary.</li> </ul>		√	√	√	√	√	
15	Engine oil	<ul style="list-style-type: none"> <li>Change.</li> <li>Check ATV for oil leakage, and correct if necessary.</li> </ul>		√		√	√	√	
16	Engine oil strainer	<ul style="list-style-type: none"> <li>Clean.</li> </ul>		√		√		√	
17	Final transmission oil	<ul style="list-style-type: none"> <li>Change.</li> <li>Check ATV for oil leakage, and correct if necessary.</li> </ul>		√				√	
18	* Moving parts and cables	<ul style="list-style-type: none"> <li>Lubricate.</li> </ul>			√	√	√	√	

NO.	ITEM	CHECK OR MAINTENANCE JOB	Whichever comes first ⇒	INITIAL			EVERY		
				month	1	3	6	6	12
				km (mi)	320 (200)	1300 (800)	2500 (1600)	2500 (1600)	5000 (3200)
				hours	20	80	160	160	320
19	* Drive select lever safety system cable	<ul style="list-style-type: none"> <li>Check operation and adjust or replace if necessary.</li> </ul>			√	√	√		
20	* Throttle lever housing and cable	<ul style="list-style-type: none"> <li>Check operation and correct if necessary.</li> <li>Check throttle cable free play and adjust if necessary.</li> <li>Lubricate throttle lever housing and cable.</li> </ul>	√	√	√	√	√		
21	* Front and rear brake switches	<ul style="list-style-type: none"> <li>Check operation and correct if necessary.</li> </ul>	√	√	√	√	√		
22	* Lights and switches	<ul style="list-style-type: none"> <li>Check operation and correct if necessary.</li> <li>Adjust headlight beams.</li> </ul>	√	√	√	√	√		
23	* V-belt	<ul style="list-style-type: none"> <li>Check operation</li> <li>Check for wear, cracks or other damage, and replace if necessary.</li> </ul>	√		√	√	√		

## TIP

---

- The air filter needs more frequent service if you are riding in unusually wet or dusty areas.
  - Hydraulic brake service
    - Regularly check and, if necessary, correct the brake fluid level.
    - Every two years replace the internal components of the brake master cylinder and caliper, and change the brake fluid.
    - Replace the brake hoses every four years and if cracked or damaged.
-

## **⚠ WARNING**

**A WARNING indicates a hazardous situation which, if not avoided, could result in death or serious injury.**

### **Checking the spark plug**

The spark plug is an important engine component, which is easy to check. Since heat and deposits will cause any spark plug to slowly erode, the spark plug should be removed and checked in accordance with the periodic maintenance and lubrication chart. In addition, the condition of the spark plug can reveal the condition of the engine.

8

#### **To remove the spark plug**

1. Remove the spark plug cap.

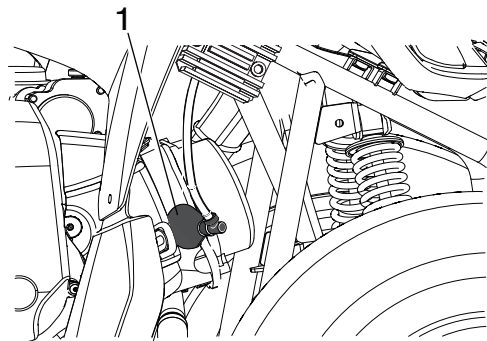

1. Spark plug cap
2. Remove the spark plug as shown, with the spark plug wrench included in the owner's tool kit.



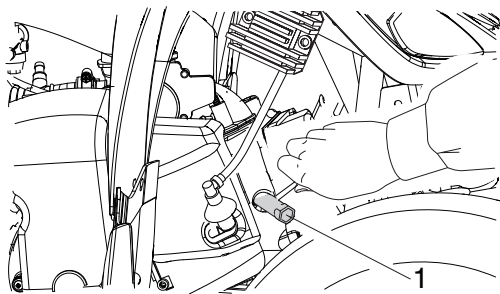

1. Spark plug wrench

### To check the spark plug

1. Check that the porcelain insulator around the center electrode of the spark plug is a medium-to-light tan (the ideal color when the ATV is ridden normally).

#### TIP

If the spark plug shows a distinctly different color, the engine could be operating improperly. Do not attempt to diagnose such problems yourself. Instead, have a Yamaha dealer check the ATV.

2. Check the spark plug for electrode erosion and excessive carbon or other deposits, and

replace it if necessary.

Specified spark plug:  
NGK/CR7HSA

### To install the spark plug

1. Measure the spark plug gap with a wire thickness gauge and, if necessary, adjust the gap to specification.

Spark plug gap:  
0.6–0.7 mm (0.024–0.028 in)

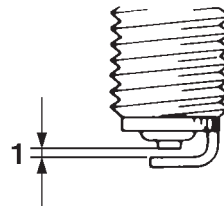

1. Spark plug gap

2. Clean the surface of the spark plug gasket and its mating surface, and then wipe off any grime from the spark plug threads.
3. Install the spark plug with the spark plug wrench, and then tighten it to the specified torque.

Tightening torque:

Spark plug:

12.0 Nm (1.20 m·kgf, 8.9 ft·lbf)

### TIP

If a torque wrench is not available when installing a spark plug, a good estimate of the correct torque is 1/4–1/2 turn past finger tight. However, the spark plug should be tightened to the specified torque as soon as possible.

4. Install the spark plug cap.

## Engine oil

The engine oil level should be checked before each ride. In addition, the oil must be changed at the intervals specified in the periodic maintenance and lubrication chart.

## To check the engine oil level

1. Place the ATV on a level surface.
2. Check the engine oil level on a cold engine.

### TIP

If the engine was started before checking the oil level, be sure to warm up the engine sufficiently, and then wait at least ten minutes until the oil settles for an accurate reading.

3. Remove the engine oil filler cap, and then wipe the dipstick off with a clean rag.

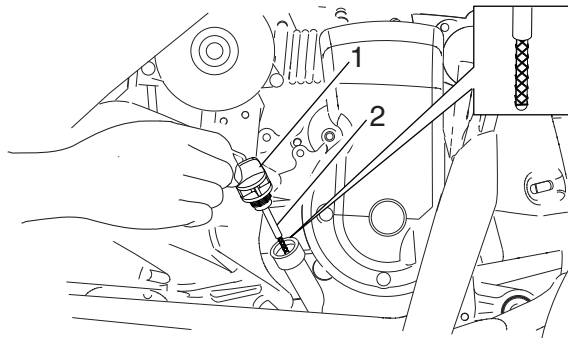

1. Engine oil filler cap
2. Dipstick

4. Insert the dipstick into the filler hole (without screwing it in), and then remove it again to check the oil level.

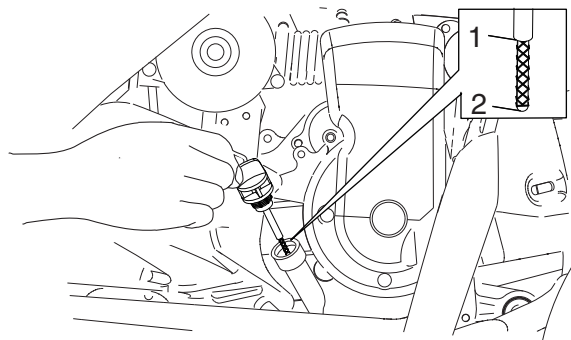

1. Maximum level mark
2. Minimum level mark

### TIP

The engine oil should be between the minimum and maximum level marks.

5. If the engine oil is at or below the minimum level mark, add sufficient oil of the recommended type to raise it to the correct level.
6. Insert the dipstick into the oil filler hole, and then tighten the engine oil filler cap.

### To change the engine oil

1. Place the ATV on a level surface.
2. Start the engine, warm it up for several minutes, and then turn it off.
3. Place an oil pan under the engine to collect the used oil.
4. Remove the engine oil filler cap, and then remove the engine oil drain bolt to drain the oil from the crankcase.

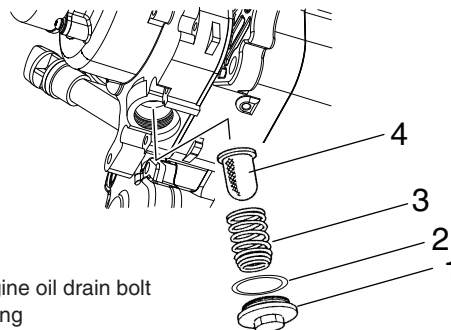

1. Engine oil drain bolt
2. O-ring
3. Spring
4. Oil filter element

5. Check the washer for damage and replace it if necessary.
6. Install the engine oil drain bolt, and then tighten it to the specified torque.

Tightening torque:  
Engine oil drain bolt:  
8 Nm (0.8m-kgf, 5.8 ft-lbf)

7. Add the specified amount of the recommended engine oil, and then install and tighten the engine oil filler cap.

Recommended oil:  
See page 10-1.  
Oil quantity:  
0.8 L (0.84 US qt) (0.70 Imp.qt)

minutes while checking it for oil leakage. If oil is leaking, immediately turn the engine off and check for the cause.

9. Turn the engine off, wait at least ten minutes, and then check the oil level and correct it if necessary.

8

## **NOTICE**

- **Do not mix any chemical additives. Do not use oils with a diesel specification of "CD" or oils of a higher quality than specified. In addition, do not use oils labeled "ENERGY CONSERVING II" or higher.**
- **Make sure that no foreign material enters the crankcase.**

8. Start the engine, and then let it idle for several

## Final transmission oil

The final transmission case must be checked for oil leakage before each ride. If any leakage is found, have a Yamaha dealer check and repair the ATV. In addition, the final transmission oil must be changed at the intervals specified in the periodic maintenance and lubrication chart.

### To change the final transmission oil

1. Place the ATV on a level surface.
2. Place an oil pan under the final transmission.
3. Remove the final transmission oil filler cap and the drain bolt to drain the oil from the final transmission oil case.
4. Install the drain bolt, and then tighten it to the specified torque.

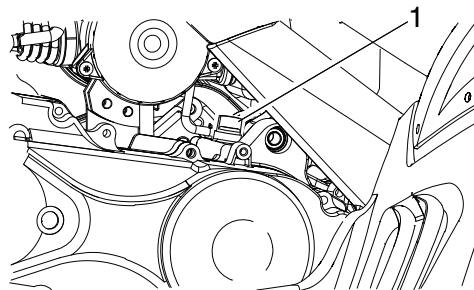

1. Final transmission oil filler cap

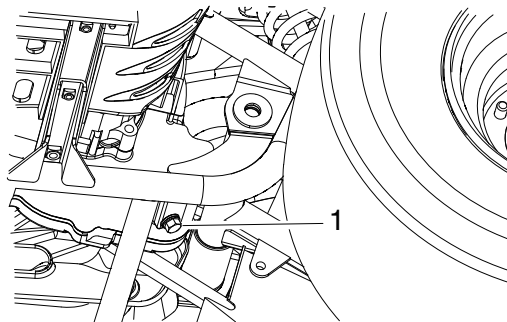

1. Final transmission oil drain bolt

Tightening torque:

Final transmission oil drain bolt:

15 Nm (1.5 m-kgf, 10.8 ft-lbf)

5. Add the specified amount of the recommended final transmission oil, and then check the oil level.

Recommended final transmission oil:

See page 10-1.

Oil quantity:

0.30 L (0.32 US qt) (0.27 Imp.qt)

## NOTICE

**Be sure no foreign material enters the final transmission case.**

6. Install and tighten the oil filler cap.
7. Check the final transmission case for oil leakage. If oil is leaking, check for the cause.

## Cleaning the air filter element

The air filter element should be cleaned at the intervals specified in the periodic maintenance and lubrication chart. Clean the air filter element more frequently if you are riding in unusually wet or dusty areas.

### TIP

There are check hoses at the bottom of the air filter case. If dust or water collects in these hoses, empty them and clean the air filter element and air filter case.

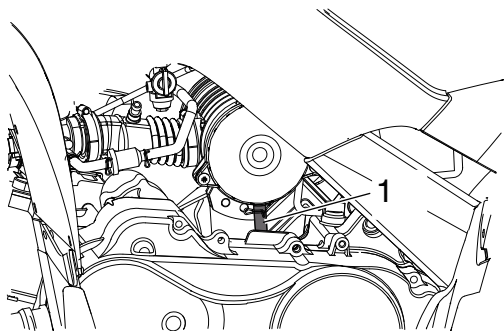

1. Air filter case check hose (left)

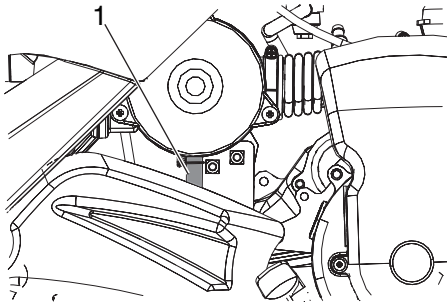

1. Air filter case check hose (right)

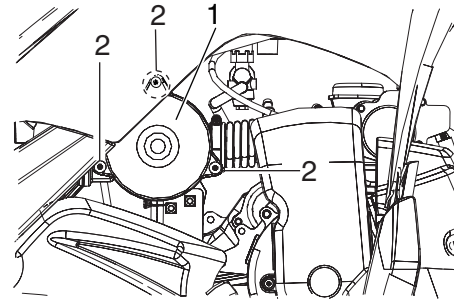

1. Air filter case cover (right)

2. Bolts

1. Remove the air filter case cover by removing the bolts.

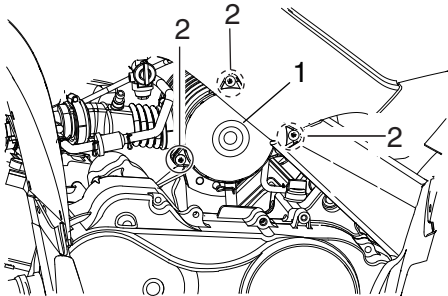

1. Air filter case cover (left)

2. Bolts

2. Remove the air filter element by removing the screw, and then pull off the sponge material from the air filter element holder.

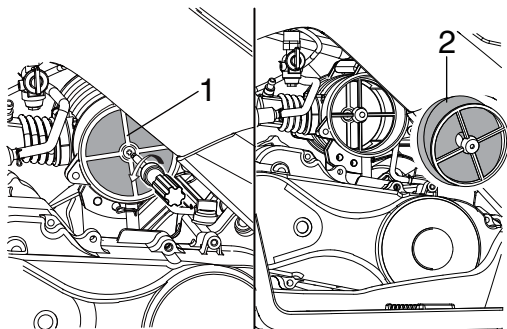

- 8
1. Air filter element holder
  2. Sponge material

3. Wash the sponge material gently but thoroughly in solvent.

**⚠ WARNING**

**POTENTIAL HAZARD**

Using low-flash-point solvents or gasoline to clean the sponge material.

**WHAT CAN HAPPEN**

Low-flash-point solvents or gasoline can catch fire or explode.

**HOW TO AVOID THE HAZARD**

Use parts cleaning solvent to clean the sponge material.

4. Squeeze the excess solvent out of the sponge material and let it dry.

**NOTICE**

Do not twist the sponge material when squeezing it.

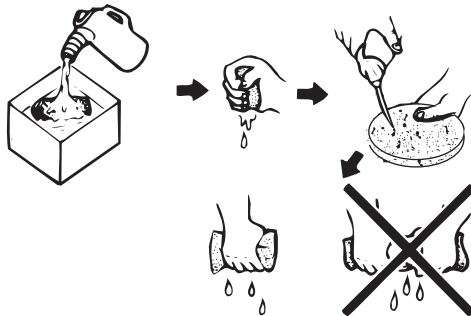

5. Check the sponge material and replace it if damaged.



6. Apply Yamaha foam air filter oil or other quality foam air filter oil to the sponge material.

#### **TIP**

The sponge material should be wet but not dripping.

7. Install the sponge material onto the air filter element holder.
8. Place the air filter element in the original position, and then install the screw.
9. Install the air filter case cover by installing the bolts.

#### **TIP**

The air filter element should be cleaned every 20–40 hours. It should be cleaned and lubricated more often if the ATV is operated in extremely dusty areas. Each time the air filter element maintenance is performed, check the air inlet of the air filter case for obstructions.

#### **NOTICE**

- **Make sure that the air filter element is properly seated in the air filter case.**
- **Never operate the engine with the air filter el-**

**ement removed. This will allow unfiltered air to enter the engine, causing rapid engine wear and possible engine damage. Additionally, operation without the air filter element will affect carburetor jetting with subsequent poor performance and possible engine overheating.**

## Cleaning the spark arrester

Be sure the exhaust pipe and muffler are cool before cleaning the spark arrester.

1. Remove the screw and nut.

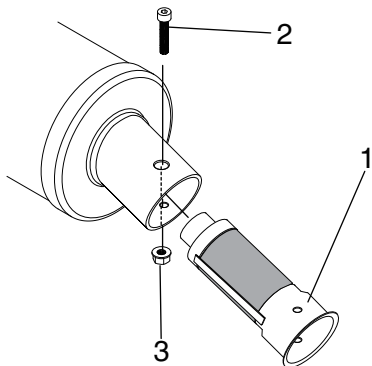

1. Spark arrester
2. Screw
3. Nut

2. Remove the spark arrester by pulling it out of the muffler.
3. Tap the spark arrester lightly, and then use a wire brush to remove any carbon deposits.
4. Insert the spark arrester into the muffler and align the screw holes.
5. Install the screw and nut, and then tighten the nut.

## **WARNING**

### **POTENTIAL HAZARD**

**Improper cleaning of the spark arrester.**

**Hot exhaust system.**

### **WHAT CAN HAPPEN**

**Could injure the eyes.**

**Could cause burns.**

**Could cause carbon monoxide poisoning, possibly leading to death.**

**Could start a fire.**

### **HOW TO AVOID THE HAZARD**

**When cleaning the spark arrester:**

**Always let the exhaust system cool prior to touching exhaust components.**

**Do not start the engine when cleaning the exhaust system.**

## **Adjusting the carburetor**

The carburetor should be checked and, if necessary, adjusted at the intervals specified in the periodic maintenance and lubrication chart. The carburetor is an important part of the engine and requires very sophisticated adjustment. Therefore, most carburetor adjustments should be left to a Yamaha dealer, who has the necessary professional knowledge and experience. The adjustment described in the following section, however, may be performed by the owner as part of routine maintenance.

### **NOTICE**

**The carburetor has been set and extensively tested at the Yamaha factory. Changing these settings without sufficient technical knowledge may result in poor performance or damage to the engine.**

8

## **Adjusting the engine idling speed**

The engine idling speed must be checked and, if necessary, adjusted as follows at the intervals specified in the periodic maintenance and lubrica-

tion chart.

### TIP

A diagnostic tachometer is needed to make this adjustment.

1. Start the engine and warm it up.

### TIP

The engine is warm when it quickly responds to the throttle.

2. Attach the tachometer to the spark plug lead.
3. Check the engine idling speed and, if necessary, adjust it to specification by turning the throttle stop screw at the carburetor. To increase the engine idling speed, turn the throttle stop screw in direction (a), and to decrease it, turn the screw in direction (b).

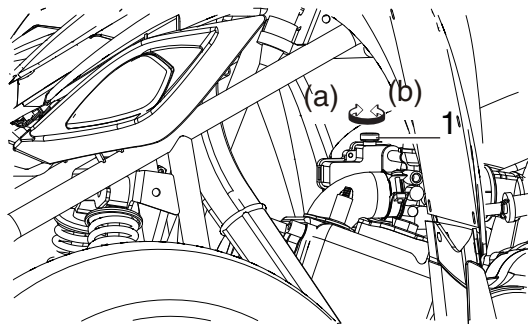

1. Throttle stop screw

Engine idling speed:  
1600–1800 r/min

### TIP

If the specified idling speed cannot be obtained as described above, have a Yamaha dealer make the adjustment.

## Checking the throttle cable free play

The throttle cable free play should be checked at the intervals specified in the periodic maintenance and lubrication chart.

The throttle cable free play should measure 1.0–3.0 mm (0.04–0.12 in) at the throttle lever. Periodically check the throttle cable free play and, if necessary, have a Yamaha dealer adjust it.

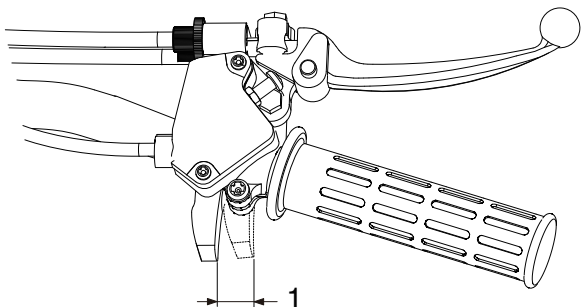

1. Throttle lever free play

## Timing chain

The timing chain stretches with use, resulting in improper valve timing and engine noise. To prevent this from occurring, the timing chain tensioner must be adjusted by a Yamaha dealer at the intervals specified in the periodic maintenance and lubrication chart.

## Valve clearance

The valve clearance changes with use, resulting in improper air-fuel mixture and/or engine noise. To prevent this from occurring, the valve clearance must be adjusted by a Yamaha dealer at the intervals specified in the periodic maintenance and lubrication chart.

## Brakes

Replacement of brake components requires professional knowledge. Brake service should be performed by a Yamaha dealer.

### **WARNING**

**Operating with improperly serviced or adjusted brakes could lead to a loss in braking ability and an accident.**

## Checking the front brake shoes

The front brake shoes must be checked for wear at the intervals specified in the periodic maintenance and lubrication chart. Front brake is provided with a wear indicator on front brake lever, which allows you

to check the brake shoe wear without having to disassemble the brake. To check the brake shoe wear, there are two adjusting bolts to indicate brake shoe wear. If the positions of adjusting bolts reach to 12mm (0.47in), the brake shoes should be replaced as a set by Yamaha dealer.

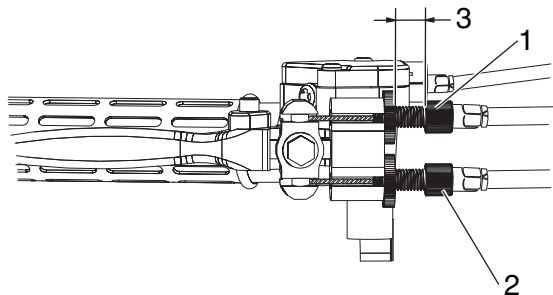

1. Upper adjusting bolt
2. Lower adjusting bolt
3. No more than 12 mm (0.47 in)

## Adjusting the front brake lever free play

The brake lever free play must be checked and, if necessary, adjusted at the intervals specified in the periodic maintenance and lubrication chart.

**TIP** Before adjusting the brake lever free play, check the front brake shoes for wear.

The brake lever free play should measure 4.0–6.0 mm (0.16–0.24 in) as shown. If the free play is incorrect, adjust it as follows.

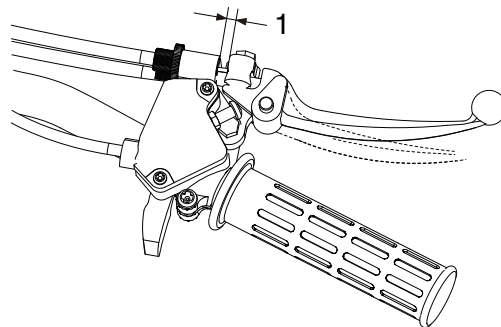

1. Brake lever free play

1. Loosen the upper locknut and fully turn in the upper adjusting bolt.
2. Loosen the lower locknut.
3. Turn the lower adjusting bolt in direction (a) to increase the free play, and in direction (b) to decrease it.

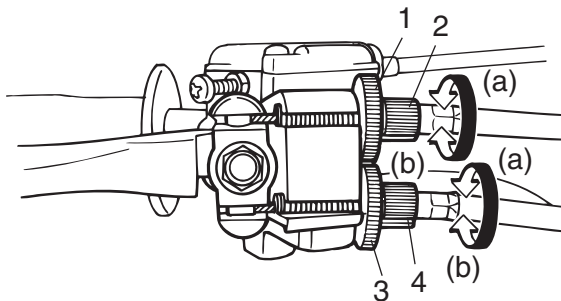

1. Upper locknut
2. Upper adjusting bolt
3. Lower locknut
4. Lower adjusting bolt

4. Tighten the lower locknut.
5. While applying the front brake, turn out the upper adjusting bolt until the upper and lower cable lengths are equal. The cable joint will become vertical.

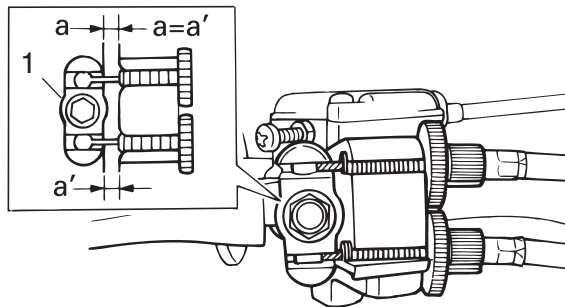

1. Cable joint
6. Tighten the upper locknut.

**⚠ WARNING**

**POTENTIAL HAZARD**

**Operating with improperly serviced or adjusted brakes.**

**WHAT CAN HAPPEN**

**You could lose braking ability, which could lead to an accident.**

## HOW TO AVOID THE HAZARD

### After servicing:

- Make sure the brakes operate smoothly and that the free play is correct.
- Make sure the brakes do not drag.

Replacement of brake components requires professional knowledge. These procedures should be performed by a Yamaha dealer.

## Checking the rear brake pads

The rear brake pads must be checked for wear at the intervals specified in the periodic maintenance and lubrication chart. Each brake pad is provided with wear indicator grooves, which allow you to check the brake pad wear without having to disassemble the brake. If a brake pad has worn to the point that the wear indicator grooves have almost disappeared, have a Yamaha dealer replace the brake pads as a set.

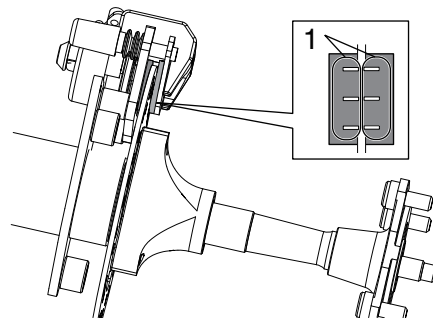

1. Wear indicator groove

## Checking the brake fluid level

Insufficient brake fluid may allow air to enter the brake system, possibly causing it to become ineffective. Before riding, check that the brake fluid is above the minimum level mark and replenish if necessary. A low brake fluid level may indicate worn brake pads and/or brake system leakage. If the brake fluid level is low, be sure to check the brake pads for wear and the brake system for leakage.



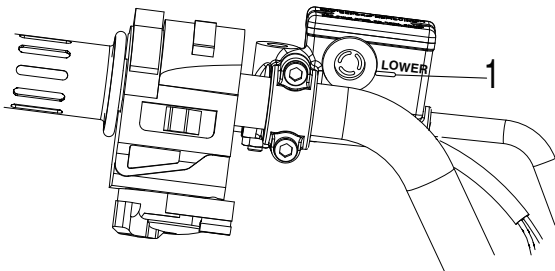

1. Minimum level mark

## Changing the rear brake fluid

Have a Yamaha dealer change the rear brake fluid at the intervals specified in the TIP after the periodic maintenance and lubrication chart. In addition, have the oil seals of the master cylinders and calipers as well as the brake hoses replaced at the intervals listed below or whenever they are damaged or leaking.

- Oil seals: Replace every two years.
- Brake hoses: Replace every four years.

Recommended brake fluid:  
DOT4

## Checking the rear brake lever free play

The brake lever free play must be checked at the intervals specified in the periodic maintenance and lubrication chart. The brake lever free play should measure 0 –1.5 mm (0 –0.06 in) as shown. If the free play is incorrect, have a Yamaha dealer check the brake system.

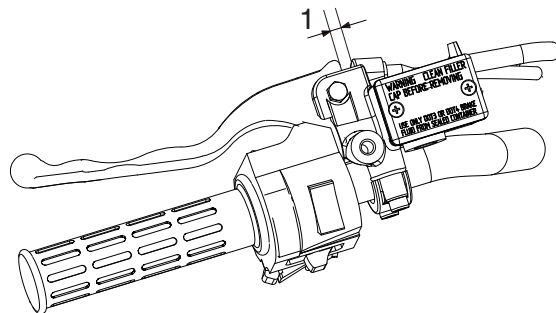

1. Brake lever free play

**⚠ WARNING**

**POTENTIAL HAZARD**

Operating with improperly serviced or adjusted brakes.

**WHAT CAN HAPPEN**

You could lose braking ability, which could lead to an accident.

**HOW TO AVOID THE HAZARD**

After servicing:

- Make sure the brakes operate smoothly and that the free play is correct.
- Make sure the brakes do not drag.
- Make sure the brakes are not spongy. All air must be bled from the brake system.

Replacement of brake components requires professional knowledge. These procedures should be performed by a Yamaha dealer.

Recommended lubricant:  
Engine oil

**⚠ WARNING**

**POTENTIAL HAZARD**

Damaged control cables.

**WHAT CAN HAPPEN**

Corrosion can result when the cable sheaths become damaged, and cables can also become frayed or kinked, which could restrict the operation of controls and lead to an accident or injury.

**HOW TO AVOID THE HAZARD**

Inspect cables frequently. Replace damaged cables.

**Checking and lubricating the front and rear brake levers**

The operation of the front and rear brake levers should be checked before each ride, and the lever pivots should be lubricated if necessary.

**Checking and lubricating the cables**

The operation and the condition of all control cables should be checked before each ride, and the cables and cable ends should be lubricated if necessary. If a cable is damaged or does not move smoothly, have a Yamaha dealer check or replace it.

**Recommended lubricant:**

Front brake lever:

Lithium-soap-based grease

Rear brake lever:

Silicone grease

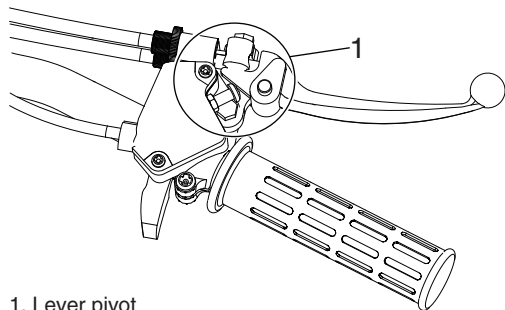

1. Lever pivot

## Checking the wheel hub bearings

The front and rear wheel hub bearings must be checked at the intervals specified in the periodic maintenance and lubrication chart. If there is play in a wheel hub or if a wheel does not turn smoothly, have a Yamaha dealer check the wheel hub bearings.

## Battery

This model is equipped with a VRLA (Valve Regulated Lead Acid) battery. There is no need to check the electrolyte or to add distilled water. However, the battery lead connections need to be checked and, if necessary, tightened.

### **NOTICE**

**Never attempt to remove the battery cell seals, as this would permanently damage the battery.**

### **WARNING**

#### **POTENTIAL HAZARD**

**Failure to handle batteries or battery electrolyte carefully.**

#### **WHAT CAN HAPPEN**

**You could be poisoned. You could be severely burned by the sulfuric acid in battery electrolyte. Batteries produce explosive gases.**

#### **HOW TO AVOID THE HAZARD**

**Avoid contact with skin, eyes or clothing. Always shield eyes when working near batteries. Keep out of reach of children.**

**Antidote:**

**EXTERNAL: Flush with water.**

**INTERNAL: Drink large quantities of water or milk. Follow with milk of magnesia, beaten egg or vegetable oil. Get prompt medical attention.**

**EYES: Flush with water for 15 minutes and get prompt medical attention. Keep batteries away from sparks, flames, cigarettes or other sources of ignition. Ventilate when charging or using in a closed space.**

8

### To charge the battery

Have a Yamaha dealer charge the battery as soon as possible if it seems to have discharged. Keep in mind that the battery tends to discharge more quickly if the ATV is equipped with optional electrical accessories.

### To store the battery

1. If the ATV will not be used for more than one month, remove the battery, fully charge it, and then place it in a cool, dry place.
2. If the battery will be stored for more than two months, check it at least once a month and fully charge it if necessary.

### To install the battery

#### TIP

Be sure the battery is fully charged.

1. Place the battery in its compartment.
2. Make sure to properly connect the battery leads to the battery terminals.

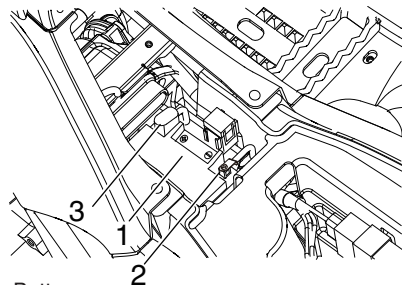

1. Battery
2. Negative lead
3. Positive lead

## NOTICE

- Always keep the battery charged. Storing a discharged battery can cause permanent battery damage.
- To charge a VRLA (Valve Regulated Lead Acid) battery, a special (constant-voltage) battery charger is required. Using a conventional battery charger will damage the battery. If you do not have access to a constant-voltage battery charger, have a Yamaha dealer charge your battery.

## Replacing the fuse

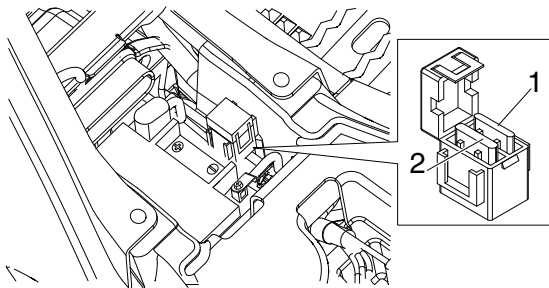

1. Fuse
2. Spare fuse

The fuse holder is located under the seat.

(See page 4-11.)

If the fuse is blown, replace it as follows.

1. Turn the key to "OFF" and turn off all electrical circuits.

## NOTICE

To prevent accidental short-circuiting, turn off the main switch when checking or replacing a fuse.

2. Remove the blown fuse, and then install a new fuse of the specified amperage.

Specified fuse:  
10 A

## ⚠ WARNING

### POTENTIAL HAZARD

Using an improper fuse.

### WHAT CAN HAPPEN

An improper fuse can cause damage to the electrical system, which could lead to a fire.

### HOW TO AVOID THE HAZARD

Always use a fuse of the specified rating. Never use a material in place of the proper fuse.

3. Turn the key to "ON" and turn on the electrical circuits to check if the devices operate.
4. If the fuse immediately blows again, have a Yamaha dealer check the electrical system.



## Removing a wheel

1. Loosen the wheel nuts.

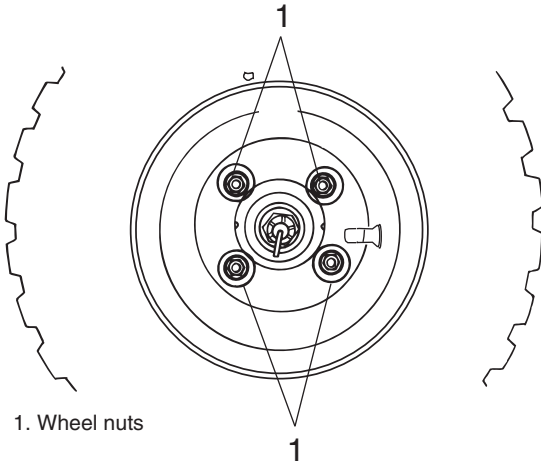

2. Elevate the ATV and place a suitable stand under the frame.
3. Remove the nuts from the wheel.
4. Remove the wheel.

1. Wheel nuts

## Installing a wheel

1. Install the wheel and the nuts.

### TIP

When installing the wheel, make sure its arrow mark  $\Rightarrow$  points toward the rotating direction of the wheel.

Front

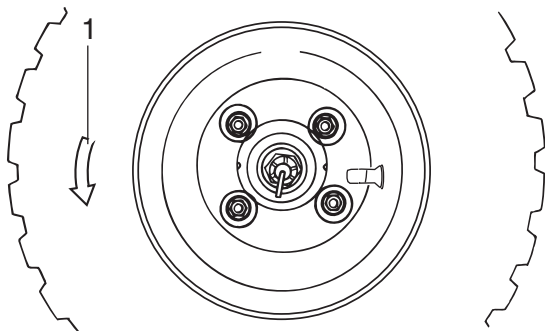

1. Arrow mark

2. Lower the ATV to the ground.
3. Tighten the wheel nuts to the specified torques.

Tightening torques:

Front wheel nut:

45 Nm (4.5 m·kgf, 33 ft·lbf)

Rear wheel nut:

45 Nm (4.5 m·kgf, 33 ft·lbf)



## Troubleshooting

Although Yamaha ATVs receive a thorough inspection before shipment from the factory, trouble may occur during operation. Any problem in the fuel, compression, or ignition systems, for example, can cause poor starting and loss of power.

The following troubleshooting chart represents a quick and easy procedure for checking these vital systems yourself. However, should your ATV require any repair, take it to a Yamaha dealer, whose skilled technicians have the necessary tools, experience, and know-how to service the ATV properly. Use only genuine Yamaha replacement parts. Imitation parts may look like Yamaha parts, but they are often inferior, have a shorter service life and can lead to expensive repair bills.



### **WARNING**

#### **POTENTIAL HAZARD**

**Checking the fuel system while smoking or near an open flame.**

#### **WHAT CAN HAPPEN**

**Fuel can ignite or explode, causing severe injury or property damage.**

#### **HOW TO AVOID THE HAZARD**

**Do not smoke when checking the fuel system. Make sure there are no open flames or sparks in the area, including pilot lights from water heaters or furnaces.**

# Troubleshooting chart

## 1. Fuel

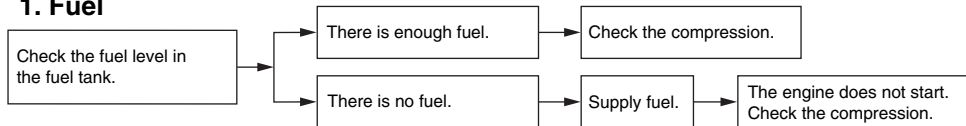

## 2. Compression

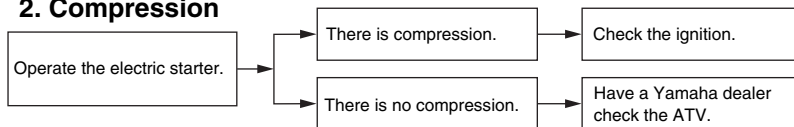

## 3. Ignition

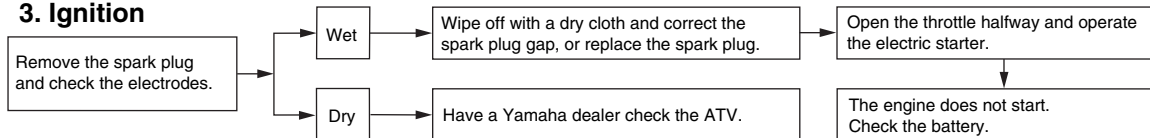

## 4. Battery

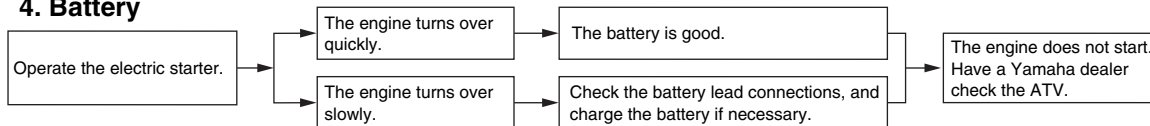

# CLEANING AND STORAGE

## Cleaning

Frequent, thorough cleaning of your ATV will not only enhance its appearance but will improve its general performance and extend the useful life of many components.

1. Before cleaning the ATV:
  - a. Block off the end of the exhaust pipe to prevent water entry. A plastic bag and strong rubber band may be used.
  - b. Make sure the spark plug and all filler caps are properly installed.
2. If the engine case is excessively greasy, apply degreaser with a paint brush. Do not apply degreaser to the wheel axles.
3. Rinse the dirt and degreaser off with a garden hose. Use only enough pressure to do the job.

### **NOTICE**

**Excessive water pressure may cause water seepage and deterioration of wheel bearings, brakes, transmission seals and electrical devices. Many expensive repair bills have resulted from improper high-pressure detergent**

**applications such as those available in coin-operated car washers.**

---

4. Once most of the dirt has been hosed off, wash all surfaces with warm water and mild, detergent-type soap. An old toothbrush or bottle brush is handy for hard-to-reach places.
5. Rinse the ATV off immediately with clean water and dry all surfaces with a chamois, clean towel or soft absorbing cloth.
6. Clean the seat with a vinyl upholstery cleaner to keep the cover pliable and glossy.
7. Automotive type wax may be applied to all painted and chrome plated surfaces. Avoid combination cleaner-waxes. Many contain abrasives which may mar the paint or protective finish. When finished cleaning, start the engine and let it idle for several minutes.

## **WARNING**

### **POTENTIAL HAZARD**

**Operation with wet brakes after washing.**

### **WHAT CAN HAPPEN**

**Wet brakes may have reduced stopping ability, increasing the chance of an accident.**

### **HOW TO AVOID THE HAZARD**

**Test the brakes after washing. Apply the brakes several times at slow speeds to let friction dry out the linings.**

## **Storage**

### **Short-term**

Always store your ATV in a cool, dry place and, if necessary, protect it against dust with a porous cover.

### **NOTICE**

- **Storing the ATV in a poorly ventilated room or covering it with a tarp while it is still wet, will allow water and humidity to seep in and cause rust.**
- **To prevent corrosion, avoid damp cellars, stables (because of the presence of ammo-**

**nia) and areas where strong chemicals are stored.**

### **Long-term**

Before storing your ATV for several months:

1. Follow all the instructions in the “Cleaning” section of this chapter.
2. Turn the fuel cock lever to “OFF”.
3. Drain the carburetor float chamber by loosening the drain bolt; this will prevent fuel deposits from building up. Pour the drained fuel into the fuel tank.
4. Fill up the fuel tank and add fuel stabilizer (if available) to prevent the fuel from deteriorating.

### **Specified amount:**

7.5 ml of stabilizer to each liter of fuel (or 1 oz of stabilizer to each gallon of fuel)

5. Perform the following steps to protect the cylinder, piston rings, etc. from corrosion.
  - a. Remove the spark plug cap and spark plug.
  - b. Pour a teaspoonful of engine oil into the spark plug bore.
  - c. Install the spark plug cap onto the spark

- plug, and then place the spark plug on the cylinder head so that the electrodes are grounded. (This will limit sparking during the next step.)
- d. Turn the engine over several times with the starter. (This will coat the cylinder wall with oil.)
  - e. Remove the spark plug cap from the spark plug, and then install the spark plug and the spark plug cap.
6. Lubricate all control cables and the pivoting points of all levers and pedals.
  7. Check and, if necessary, correct the tire air pressure, and then block up the ATV so that all of its wheels are off the ground. Alternatively, turn the wheels a little every month in order to prevent the tires from becoming degraded in one spot.
  8. Cover the muffler outlet with a plastic bag to prevent moisture from entering it.
  9. Remove the battery and fully charge it. Store it in a cool, dry place and charge it once a month. Do not store the battery in an excessively cold or warm place [less than 0 °C (30 °F) or more than 30 °C (90 °F)]. For more information on storing the battery, see page 8-28.

---

**TIP**

Make any necessary repairs before storing the ATV.

---

# SPECIFICATIONS

## Dimensions:

- Overall length:  
1490 mm (58.7 in)
- Overall width:  
885 mm (34.8 in)
- Overall height:  
910 mm (35.8 in)
- Seat height:  
654 mm (25.7 in)
- Wheelbase:  
1010 mm (39.8 in)
- Ground clearance:  
100 mm (3.9 in)
- Minimum turning radius:  
2900 mm (114 in)

## Weight:

- With oil and fuel:  
120.0 kg (264 lb)

## Engine:

- Engine type:  
Forced air cooled 4-stroke
- Cylinder arrangement:  
Single cylinder
- Displacement:  
88 cm<sup>3</sup> (5.37 cu. in)
- Bore x stroke:  
47.0 x 51.0 mm (1.85 x 2.0 in)

Compression ratio:

10.2 : 1

Starting system:

Electric starter & kickstarter

Lubrication system:

Wet sump

## Engine oil:

Type:

YAMALUBE 4, SAE5W-30 or SAE10W-40 or SAE20W-50

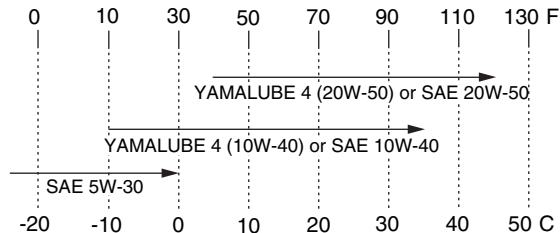

Recommended engine oil grade:

API service SG type or higher, JASO standard MA

**Engine oil quantity:**

Periodic oil change:

0.8 L (0.84 US qt) (0.70 Imp.qt)

**Final transmission oil:**

Type:

SAE80 API GL-4 Hypoid gear oil

Quantity:

0.30 L (0.32 US qt) (0.27 Imp.qt)

**Air filter:**

Air filter element:

Wet element

**Fuel:**

Recommended fuel:

Unleaded gasoline only

Fuel tank capacity:

4.8 L (1.27 US gal) (1.06 Imp.gal)

Fuel reserve amount:

1.0l(0.26 US gal) (0.22 Imp.gal)

**Carburetor:**

Manufacturer:

TK

Type x quantity:

SVR 22-1G x 1

**Spark plug (s):**

Manufacturer/model:

NGK/CR7HSA

Spark plug gap:

0.6–0.7 mm (0.024–0.028 in)

**Clutch:**

Clutch type:

Dry, centrifugal automatic

**Transmission:**

Primary reduction system:

V-belt

Primary reduction ratio:

2.47-0.61:1

Secondary reduction system:

Spur

Secondary reduction ratio:

41/15 × 45/13 (9.462)

Third reduction system:

Chain drive

Third reduction ratio:

28/13(2.154)

Transmission type:

V-belt automatic

**Chassis:**

Frame type:

Steel tube frame

Caster angle:

4.0 °

Trail:

16 mm (0.63 in)

**Front tire:**

Type:

Tubeless

Size:

AT18 x 7-8

Manufacturer/model:

MAXXIS/M939

**Rear tire:**

Type:

Tubeless

Size:

AT18 x 9-8

Manufacturer/model:

MAXXIS/M940

**Loading:**

Maximum loading limit:

70.0 kg (154 lb)

(Total weight of rider, cargo, accessories, and tongue)

**Tire air pressure (measured on cold tires):**

Recommended:

Front:

25 kPa (3.6 psi) (0.25 kgf/cm<sup>2</sup>)

Rear:

25 kPa (3.6 psi) (0.25 kgf/cm<sup>2</sup>)

Minimum:

Front:

22 kPa (3.2 psi) (0.22 kgf/cm<sup>2</sup>)

Rear:

22 kPa (3.2 psi) (0.22 kgf/cm<sup>2</sup>)**Front wheel:**

Wheel type:

Panel wheel

Rim size:

8 x 5.5AT

**Rear wheel:**

Wheel type:

Panel wheel

Rim size:

8 x 7AT

**Front brake:**

Type:

Drum brake

Operation:

Right hand operation

**Rear brake:**

Type:

Single disc brake

Operation:

Left hand operation

Recommended fluid:

DOT4

**Front suspension:**

Type:

Double wishbone

Spring/shock absorber type:

Coil spring/oil damper



Wheel travel:  
111 mm (4.4 in)

### **Rear suspension:**

Type:  
Swingarm  
Spring/shock absorber type:  
Coil spring/oil damper  
Wheel travel:  
83 mm (3.3 in)

### **Electrical system:**

Ignition system:  
CDI  
Charging system:  
AC magneto

### **Battery:**

Model:  
GTX5L-BS  
Voltage, capacity:  
12 V, 4.0 AH

### **Fuses:**

Main fuse:  
10 A

# CONSUMER INFORMATION

## Identification numbers

Record the key identification number, vehicle identification number and model label information in the spaces provided below for assistance when ordering spare parts from a Yamaha dealer or for reference in case the ATV is stolen.

### ● KEY IDENTIFICATION NUMBER:

### ● VEHICLE IDENTIFICATION NUMBER:

### ● MODEL LABEL INFORMATION:

## Key identification number

The key identification number is stamped into the key. Record this number in the space provided and use it for reference when ordering a new key.

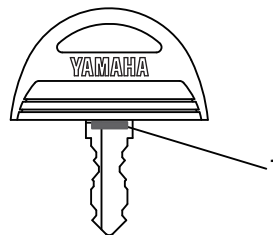

1. Key identification number

## Vehicle identification number

The vehicle identification number is stamped into the frame.

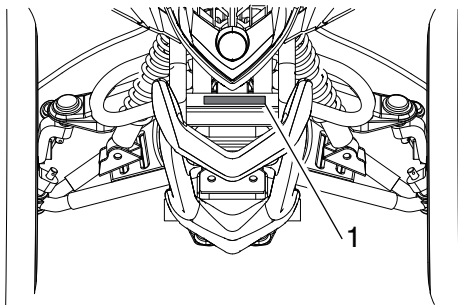

1. Vehicle identification number

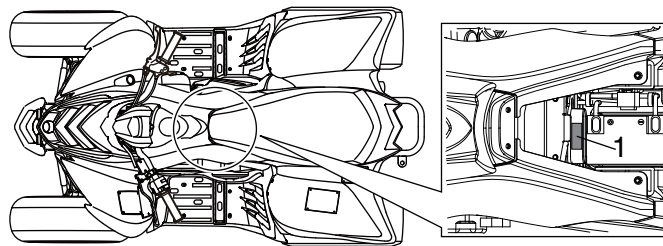

1. Model label

**TIP** \_\_\_\_\_  
The vehicle identification number is used to identify your ATV.

---

### **Model label**

The model label is affixed at the location in the illustration. Record the information on this label in the space provided. This information will be needed when ordering spare parts from a Yamaha dealer.

## Noise regulation

### TAMPERING WITH NOISE CONTROL SYSTEM PROHIBITED:

Federal law prohibits the following acts or the causing thereof: (1) The removal or rendering inoperative by any person other than for purposes of maintenance, repair, or replacement of any device or element of design incorporated into any new vehicle for the purpose of noise control prior to its sale or delivery to the ultimate purchaser or while it is in use or (2) the use of the vehicle after such device or element of design has been removed or rendered inoperative by any person.

“AMONG THOSE ACTS PRESUMED TO CONSTITUTE TAMPERING ARE THE ACTS LISTED BELOW”.

These acts include tampering with the following systems; i.e., modification, removal, etc.

#### **Exhaust system**

- Muffler
- Exhaust pipe
- Silencer

#### **Intake system**

- Air cleaner case
- Air cleaner element
- Intake duct

## Maintenance record

Copies of work orders and/or receipts for parts you purchase and install will be required to document maintenance done in accordance with the warranty. The chart below is printed only as a reminder to you that the maintenance work is required. It is not acceptable proof of maintenance work.

MAINTENANCE INTERVAL			DATE OF SERVICE	MILEAGE	SERVICING DEALER NAME AND ADDRESS	REMARKS
month	km (mi)	hours				
1	320 (200)	20				
3	1300 (800)	80				
6	2500 (1600)	160				
12	5000 (3200)	320				
18	7500 (4800)	480				
24	10000 (6400)	640				
30	12500 (8000)	800				
36	15000 (9600)	960				
42	17500 (11200)	1120				
48	20000 (12800)	1280				
54	22500 (14400)	1440				
60	25000 (16000)	1600				

# YAMAHA MOTOR CORPORATION, U.S.A. ATV LIMITED WARRANTY

Yamaha Motor Corporation, U.S.A. hereby warrants that new Yamaha ATVs purchased from an authorized Yamaha ATV dealer in the continental United States will be free from defects in material and workmanship for the period of time stated herein, subject to certain stated limitations.

**THE PERIOD OF WARRANTY** for Yamaha ATVs shall be six (6) months from the date of purchase.

**DURING THE PERIOD OF WARRANTY** any authorized Yamaha ATV dealer will, free of charge, repair or replace any part adjudged defective by Yamaha due to faulty workmanship or material from the factory. Parts used in warranty repairs will be warranted for the balance of the product's warranty period. All parts replaced under warranty become property of Yamaha Motor Corp. U.S.A.

**GENERAL EXCLUSIONS** from this warranty shall include any failures caused by:

- a. Competition or racing use.
- b. Installation of parts or accessories that are not qualitatively equivalent to genuine Yamaha parts.
- c. Abnormal strain, neglect, or abuse.
- d. Lack of proper maintenance.
- e. Accident or collision damage.
- f. Modification to original parts.
- g. Damage due to improper transportation.

**SPECIFIC EXCLUSIONS** from this warranty shall include parts replaced due to normal wear or routine maintenance, such as spark plugs, oil, oil filter, air filter, and brake shoes.

**THE CUSTOMER'S RESPONSIBILITY** under this warranty shall be to:

1. Operate and maintain the ATV as specified in the appropriate owner's manual;
2. Give notice to an authorized Yamaha ATV dealer of any and all apparent defects within ten (10) days after discovery, and make the machine available at that time for inspection and repairs at such dealer's place of business.

**WARRANTY TRANSFER:** To transfer the warranty from the original purchaser to any subsequent purchaser(s), it is imperative that the machine be inspected and registered for warranty by an authorized Yamaha ATV dealer. In order for this warranty to remain in effect, this inspection and registration must take place within ten (10) days after transfer. An inspection and registration fee will be charged for this service.

## **EMISSION CONTROL SYSTEM WARRANTY**

Yamaha Motor Corporation, USA also warrants to the ultimate purchaser and each subsequent purchaser of each 2006 and later model Yamaha ATV covered by this warranty that the vehicle is designed, built, and equipped so as to conform at the time of sale with all U.S. emissions standards applicable at the time of manufacture and that it is free from defects in materials and workmanship which would cause it not to meet these standards

within the period listed immediately below. Failures other than those resulting from defects in material or workmanship which arise solely as a result of owner abuse and/or lack of proper maintenance are not covered by this warranty.

## **All Models**

Thirty (30) months from the original purchase date

**YAMAHA MOTOR CORPORATION, U.S.A. MAKES NO OTHER WARRANTY OF ANY KIND, EXPRESSED OR IMPLIED. ALL IMPLIED WARRANTIES OF MERCHANTABILITY AND FITNESS FOR A PARTICULAR PURPOSE WHICH EXCEED THE OBLIGATIONS AND TIME LIMITS STATED IN THIS WARRANTY ARE HEREBY DISCLAIMED BY YAMAHA MOTOR CORPORATION, U.S.A. AND EXCLUDED FROM THIS WARRANTY.**

**SOME STATES DO NOT ALLOW LIMITATIONS ON HOW LONG AN IMPLIED WARRANTY LASTS, SO THE ABOVE LIMITATION MAY NOT APPLY TO YOU. ALSO EXCLUDED FROM THIS WARRANTY ARE ANY INCIDENTAL OR CONSEQUENTIAL DAMAGES INCLUDING LOSS OF USE. SOME STATES DO NOT ALLOW THE EXCLUSION OR LIMITATION OF INCIDENTAL OR CONSEQUENTIAL DAMAGES, SO THE ABOVE EXCLUSION MAY NOT APPLY TO YOU.**

**THIS WARRANTY GIVES YOU SPECIFIC LEGAL RIGHTS, AND YOU MAY ALSO HAVE OTHER RIGHTS WHICH VARY FROM STATE TO STATE.**

**YAMAHA MOTOR CORPORATION, U.S.A.  
P.O. Box 6555  
Cypress, California 90630**

## WARRANTY QUESTIONS AND ANSWERS

- Q. What costs are my responsibility during the warranty period?
- A. The customer's responsibility includes all costs of normal maintenance services, non-warranty repairs, accident and collision damages, and oil, oil filters, air filters, spark plugs, and brake shoes.
- Q. What are some examples of "abnormal" strain, neglect, or abuse?
- A. These terms are general and overlap each other in areas. Specific examples include: Running the machine out of oil, sustained high rpm, full-throttle, operating the machine with a broken or damaged part which causes another part to fail, damage or failure due to improper or careless transportation and or tie-down. If you have any specific questions on operation or maintenance, please contact your dealer for advice.
- Q. Does the warranty cover incidental costs such as towing or transportation due to a failure?
- A. No. The warranty is limited to repair of the machine itself.
- Q. May I perform any or all of the recommended maintenance shown in the Owner's Manual instead of having the dealer do them?
- A. Yes, if you are a qualified mechanic and follow the procedures specified in the Owner's and Service Manual. We do recommend, however, that items requiring special tools or equipment be done by a Yamaha ATV dealer.
- Q. Will the warranty be void or cancelled if I do not operate or maintain my new ATV exactly as specified in the Owner's Manual?
- A. No. The warranty on a new ATV cannot be "voided" or "cancelled." **However, if a particular failure is caused by operation or maintenance other than as described in the Owner's Manual, that failure may not be covered under warranty.**
- Q. What responsibility does my dealer have under this warranty?
- A. Each Yamaha ATV dealer is expected to:
1. Completely set up every new machine before sale.
  2. Explain the operation, maintenance, and warranty requirements to your satisfaction at the time of sale, and upon your request at any later date.
  3. Each Yamaha ATV dealer is held responsible for his setup, service and warranty repair work.
- Q. Is the warranty transferable to second owners?
- A. Yes. The remainder of the existing warranty can be transferred upon request. The unit has to be inspected and re-registered by an authorized Yamaha ATV dealer for the policy to remain effective.

## CUSTOMER SERVICE

If your machine requires warranty service, you must take it to any authorized Yamaha ATV dealer within the continental United States. Be sure to bring your warranty registration card or other valid proof of the original date of purchase. If a question or problem arises regarding warranty, first contact the owner of the dealership. Since all warranty matters are handled at the dealer level, this person is in the best position to help you. If you are still not satisfied and require additional assistance, please write:

YAMAHA MOTOR CORPORATION U.S.A.  
CUSTOMER RELATIONS DEPARTMENT  
P.O. Box 6555  
Cypress, California 90630

When contacting Yamaha Motor Corporation, U.S.A. don't forget to include any important information such as names, addresses, model, V.I.N. (frame number), dates, and receipts.

## CHANGE OF ADDRESS

The federal government requires each manufacturer of a motor vehicle to maintain a complete, up-to-date list of all first purchasers against the possibility of a safety-related defect and recall. This list is compiled from the purchase registrations sent to Yamaha Motor Corporation, U.S.A. by the selling dealer at the time of your purchase.

If you should move after you have purchased your new ATV, please advise us of your new address by sending a postcard listing your ATV model name, V.I.N. (frame number), dealer number (or dealer's name) as it is shown on your warranty card, your name and new mailing address. Mail to:

YAMAHA MOTOR CORPORATION, U.S.A.  
P.O. Box 6555  
Cypress, California 90630  
Attention: Warranty Department

This will ensure that Yamaha Motor Corporation, U.S.A. has an up-to-date registration record in accordance with federal law.

## YAMAHA EXTENDED SERVICE (Y.E.S.)

Keep your Yamaha protected even after your warranty expires with genuine Yamaha Extended Service (Y.E.S.).

- Y.E.S. is designed and administered by Yamaha Motor Corporation to provide maximum owner satisfaction. You get uninterrupted factory-backed coverage for extra peace of mind.
- Y. E. S. is flexible. You choose the plan that's right for you: 12 months, 24 months, or 36 months beyond your warranty period.
- Y.E.S. is designed and administered by the same Yamaha people who handle your warranty – and it shows in the comprehensive coverage benefits. There are no mileage limitations. Coverage isn't limited to "moving parts" or the "drive train" like many other plans. And Y.E.S. covers manufacturing defects just like the warranty. See the sample contract at your Yamaha dealer to see how comforting uninterrupted factory-backed protection can be.
- You don't have to pay anything for covered repairs. There's no deductible to pay, and repairs aren't "pro-rated." You don't have any "out-of-pocket" expenses for covered repairs.

- In addition, Travel and Recreation Interruption Protection (TRIP) is included at no extra cost. TRIP gives you up to \$150 reimbursement per occurrence for any reasonable expenses you incur because your Yamaha needs covered service: replacement vehicle rental, emergency towing, phone calls, even food and lodging when you are away from home. This superb coverage goes into effect when you purchase Y.E.S., so it applies to any warranty repairs as well as covered repairs during your entire Y.E.S. plan period.
- Y.E.S. coverage is honored at any authorized Yamaha dealer nationwide.
- Y.E.S. coverage is transferable to a new owner if you sell or trade in your ATV. That can make your Yamaha much more valuable!

This excellent Y.E.S. plan coverage is only available to Yamaha owners like you, and only while your Yamaha is still within the Yamaha Limited Warranty period. So visit your authorized Yamaha dealer to get all the facts. He can show you how easy it is to protect your investment with Yamaha Extended Service.



We urge you to act now. You'll get the excellent benefits of TRIP coverage right away, and you'll rest easy knowing you'll have strong factory-backed protection even after your Yamaha Limited Warranty expires. You can also save money: Y.E.S. costs less within the first 90 days after you buy your Yamaha. See your dealer today!

A special note:

If visiting your dealer isn't convenient, contact Yamaha with your Primary ID number (your frame number). We'll be happy to help you get the Y.E.S. coverage you need.

Yamaha Service Marketing  
P.O. Box 6555  
Cypress, CA 90630



**YAMAHA EXTENDED SERVICE**

 **WARNING**

**A WARNING indicates a hazardous situation which, if not avoided, could result in death or serious injury.**

***PROTECT YOUR INVESTMENT***

***Use Genuine YAMAHA Parts and Accessories***

***See your Authorized YAMAHA Dealer for a Genuine YAMAHA Service Manual.***

# INDEX

## A

- Accessories and loading ..... 6-6
- Air filter element, cleaning..... 8-15

## B

- Battery .....8-28
- Brake lever, front.....4-6
- Brake lever, rear.....4-6
- Brake lever free play, checking the rear.....8-26
- Brake lever free play, adjusting the front.....8-23
- Brake levers, checking and lubricating ..... 8-27
- Brakes, front and rear.....5-3
- Brake shoes, checking the front ..... 8-22
- Brake pads, checking the rear.....8-25
- Brake fluid level, checking the rear.....8-25
- Brake fluid level, changing the rear.....8-26

## C

- Cables, checking and lubricating ..... 8-27
- Carburetor, adjusting..... 8-20
- Chassis fasteners..... 5-7
- Choke ..... 4-11
- Cleaning.....9-1

## E

- Engine break-in ..... 6-4
- Engine, cold start.....6-1
- Engine idling speed..... 8-20

- Engine oil.....5-3, 8-11
- Engine, starting a warm.....6-3
- Engine stop switch.....4-2
- Engine speed limiter plate..... 4-5

## F

- Final transmission oil ..... 5-3, 8-14
- Fuel.....4-8, 5-3
- Fuel cock.....4-10
- Fuel tank cap.....4-8
- Fuse, replacing.....8-30

## H

- Handlebar switches ..... 4-2

## I

- Identification numbers ..... 11-1
- Instruments and switches.....5-7

## K

- Key identification number ..... 11-1
- Kick starter ..... 4-12

## L

- Label locations.....2-1

## M

- Main switch ..... 4-1
- Maintenance and lubrication chart.....8-5
- Maintenance chart, emission control system.....8-3
- Model label.....11-2

**O**

Owner's manual and tool kit..... 8-1

**P**

Parking ..... 6-4

Parking brake ..... 4-7

Parking on a slope ..... 6-5

Part locations ..... 3-1

Pre-operation check list..... 5-1

**R**

Riding your ATV ..... 7-1

**S**

Safety information ..... 1-1

Seat ..... 4-11

Spark arrester, cleaning ..... 8-19

Spark plug, checking ..... 8-9

Specifications ..... 10-1

Speed limiters..... 4-3

Start switch..... 4-2

Storage..... 9-2

**T**

Throttle cable free play, checking.....8-21

Throttle lever.....4-3, 5-4

Timing chain.....8-22

Tire pressure, measuring ..... 5-5

Tires ..... 5-4

Tire wear limit..... 5-6

Troubleshooting.....8-34

Troubleshooting chart.....8-35

**V**

Valve clearance..... 8-22

Vehicle identification number ..... 11-1

Vehicle speed limiter ..... 4-4

**W**

Wheel hub bearings, checking ..... 8-28

Wheel, installing ..... 8-33

Wheel, removing ..... 8-32

## **⚠ WARNING**

**Improper ATV use can result in SEVERE INJURY or DEATH.**



**ALWAYS USE  
AN APPROVED  
HELMET AND  
PROTECTIVE GEAR**



**NEVER USE  
ON PUBLIC  
ROADS**



**NEVER CARRY  
PASSENGERS**



**NEVER USE  
WITH DRUGS  
OR ALCOHOL**

### **NEVER operate:**

- without proper training or instruction.
- at speeds too fast for your skills or the conditions.
- on public roads-a collision can occur with another vehicle.
- with a passenger-passengers affect balance and steering and increase risk of losing control.

### **ALWAYS:**

- use proper riding techniques to avoid vehicle overturns on hills and rough terrain and in turns.
- avoid paved surfaces-pavement may seriously affect handling and control.

**LOCATE AND READ OWNER'S MANUAL. FOLLOW ALL INSTRUCTIONS AND WARNINGS.  
(For replacement manual, call 1-800-532-1558)**



YAMAHA MOTOR CO., LTD.

PRINTED ON RECYCLED PAPER

Download from [Www.Somanuals.com](http://Www.Somanuals.com). All Manuals Search And Download.

PRINTED IN TAIWAN  
2008.07  
(E)

Dear Yamaha ATV Owner: Please Review this IMPORTANT SAFETY CARD before operating your ATV (If card is not attached, call 1-800-962-7926).

Dear New Yamaha ATV Owner:

CONGRATULATIONS ON THE PURCHASE OF YOUR NEW YAMAHA ATV. You have purchased a quality Yamaha product that, with proper use and care, will provide hours of riding pleasure. **BEFORE YOU OPERATE YOUR NEW ATV, Yamaha recommends these important points:**

- READ YOUR OWNER'S MANUAL
- A CHILD UNDER 6 YEARS OLD SHOULD NOT OPERATE AN ATV WITH ENGINE SIZE 50CC OR GREATER
- A CHILD UNDER 12 YEARS OLD SHOULD NOT OPERATE AN ATV WITH ENGINE SIZE 70CC OR GREATER
- A CHILD UNDER 16 YEARS OLD SHOULD NOT OPERATE AN ATV WITH ENGINE SIZE GREATER THAN 90CC
- TAKE THE FREE HANDS-ON TRAINING COURSE OFFERED BY YAMAHA – ASK YOUR DEALER FOR DETAILS OR CALL 1-800-887-2887

If you have any questions about these points, **or if you purchased your ATV from an authorized Yamaha dealership and were not informed of the age recommendation for your ATV by the dealership**, please fill out the information below and mail this card to yamaha **today**.

Name:

\_\_\_\_\_

ATV Model:

\_\_\_\_\_

Purchase Date:

\_\_\_\_\_

MO. DAY YR.

Address:

\_\_\_\_\_

Primary I.D. (Engine Number):

\_\_\_\_\_

Telephone:

( ) \_\_\_\_\_

Dealer Name & Address:

\_\_\_\_\_



NO POSTAGE  
NECESSARY  
IF MAILED  
IN THE  
UNITED STATES



POSTAGE WILL BE PAID BY ADDRESSEE

**YAMAHA MOTOR CORPORATION U.S.A.**  
**P.O. BOX 6555**  
**CYPRESS, CALIFORNIA 90630-9989**

ATTN: SALES ADMINISTRATION

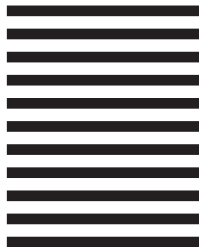

## Free Manuals Download Website

<http://myh66.com>

<http://usermanuals.us>

<http://www.somanuals.com>

<http://www.4manuals.cc>

<http://www.manual-lib.com>

<http://www.404manual.com>

<http://www.luxmanual.com>

<http://aubethermostatmanual.com>

Golf course search by state

<http://golfingnear.com>

Email search by domain

<http://emailbydomain.com>

Auto manuals search

<http://auto.somanuals.com>

TV manuals search

<http://tv.somanuals.com>