

YAMAHA

SNOWMOBILE

OWNER'S MANUAL

BR250TB

LIT-12628-01-85

8BD-28199-13

MACHINE IDENTIFICATION

Identification numbers record

A. FRAME NUMBER:

B. ENGINE NUMBER (PRIMARY I.D.):

C. KEY NUMBER:

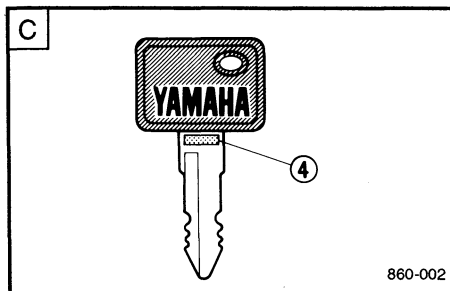
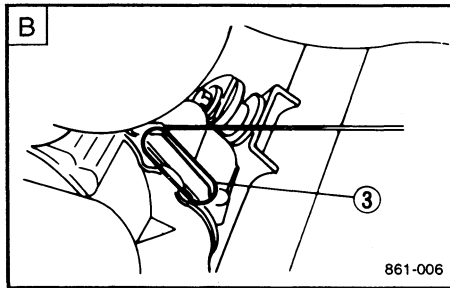
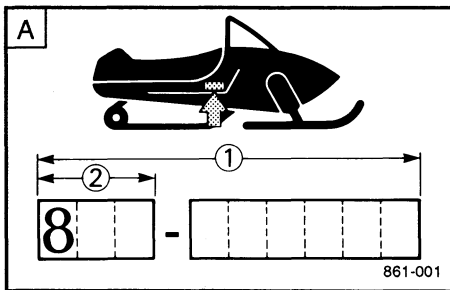

Record your frame number, engine number (Primary I.D.) and key number in the spaces provided, to assist you in ordering spare parts from your Yamaha dealer.

- ① The **frame number** is the nine-digit number stamped on the frame of the machine. (See Fig. [A](#))
- ② The **model code number** is the first three digits of the frame number.
- ③ The **engine number** is stamped in the location as shown. (See Fig. [B](#))
- ④ **Key number** (See Fig. [C](#))

Also, record and keep these I.D. numbers in a separate place in case your machine is stolen.

ESS00000

INTRODUCTION

Congratulations! Your choice of a Yamaha snowmobile assures you of the highest quality and dependability. Your Yamaha snowmobile is manufactured by a company well-known for excellence in the field of snowmobiles. The most advanced production equipment and technology have made Yamaha one of the best machine manufacturers. We are confident that this snowmobile will meet the greatest expectations of our customers. This manual is designed to acquaint you with the operation of this snowmobile and minor maintenance required for satisfactory service.

Should major repairs ever be required, you are advised to consult a nearby Yamaha dealer who has the techniques, tools and parts to ensure your satisfaction. We hope that the information within this booklet will help you enjoy many hours of pleasure with your Yamaha snowmobile.

**BR250TB
OWNER'S MANUAL
©1997 by Yamaha Motor
Corporation, U.S.A.
1st Edition, February 1997
All rights reserved.
Any reprinting or
unauthorized use without
the written permission of
Yamaha Motor Corporation,
U.S.A. is expressly prohibited.
Printed in Japan
P/N LIT-12628-01-85**



⚠ WARNING

PLEASE READ AND UNDERSTAND THIS MANUAL COMPLETELY BEFORE OPERATING THE MACHINE.

NOTE:

- Yamaha continually seeks advancements in product design and quality. Therefore, while this manual contains the most current product information available at the time of printing, there may be minor discrepancies between your machine and this manual. If there is any question concerning this manual, please consult your Yamaha dealer.
- This manual should be considered a permanent part of this machine and should remain with this machine when resold.

Particularly important information is distinguished in this manual by the following notations.



The Safety Alert Symbol means **ATTENTION! BECOME ALERT! YOUR SAFETY IS INVOLVED!**

⚠ WARNING

Failure to follow **WARNING** instructions could result in severe injury or death to the machine operator, a bystander, or a person inspecting or repairing the machine.

CAUTION

A **CAUTION** indicates special precautions that must be taken to avoid damage to the machine.

NOTE:

A **NOTE** provides key information to make procedures easier or clearer.

CONTENTS

<p>SNOWMOBILE LIMITED WARRANTY 1-1</p> <p>YAMAHA EXTENDED SERVICE (Y.E.S.) 1-4</p> <p>LOCATION OF THE IMPORTANT LABELS 2-1</p> <p>SAFETY INFORMATION 3-1</p> <p style="padding-left: 20px;">BEFORE OPERATING 3-1</p> <p style="padding-left: 20px;">OPERATION 3-3</p> <p style="padding-left: 20px;">MAINTENANCE AND STORAGE 3-5</p> <p>DESCRIPTION 4-1</p> <p>CONTROL FUNCTIONS 5-1</p> <p style="padding-left: 20px;">MAIN SWITCH 5-1</p> <p style="padding-left: 20px;">STARTER LEVER (CHOKE) 5-1</p> <p style="padding-left: 20px;">PRIMER PUMP KNOB 5-2</p> <p style="padding-left: 20px;">THROTTLE LEVER 5-2</p> <p style="padding-left: 20px;">THROTTLE OVERRIDE SYSTEM (T.O.R.S.) 5-2</p> <p style="padding-left: 20px;">ENGINE STOP SWITCH 5-3</p> <p style="padding-left: 20px;">BRAKE LEVER 5-4</p> <p style="padding-left: 20px;">PARKING BRAKE BUTTON 5-4</p> <p style="padding-left: 20px;">V-BELT GUARD 5-5</p> <p style="padding-left: 20px;">SHROUD LATCH 5-5</p> <p style="padding-left: 20px;">ENGINE ROOM PLATE 5-6</p> <p style="padding-left: 20px;">FUEL TANKS 5-7</p> <p style="padding-left: 20px;">FUEL COCK LEVER 5-8</p> <p style="padding-left: 20px;">V-BELT HOLDER 5-9</p> <p style="padding-left: 20px;">HEADLIGHT BEAM SWITCH 5-9</p> <p style="padding-left: 20px;">REAR CARRIER 5-9</p> <p style="padding-left: 20px;">TOW HITCH 5-10</p>	<p>PRE-OPERATION CHECKS 6-1</p> <p style="padding-left: 20px;">FUEL 6-1</p> <p style="padding-left: 20px;">ENGINE OIL 6-3</p> <p style="padding-left: 20px;">THROTTLE LEVER 6-3</p> <p style="padding-left: 20px;">MANUAL STARTER 6-3</p> <p style="padding-left: 20px;">THROTTLE OVERRIDE SYSTEM (T.O.R.S.) CHECK 6-4</p> <p style="padding-left: 20px;">BRAKE 6-5</p> <p style="padding-left: 20px;">V-BELT 6-5</p> <p style="padding-left: 20px;">DRIVE V-BELT GUARD 6-6</p> <p style="padding-left: 20px;">DRIVE TRACK 6-6</p> <p style="padding-left: 20px;">SLIDE RUNNERS 6-6</p> <p style="padding-left: 20px;">SKI/SKI RUNNER 6-7</p> <p style="padding-left: 20px;">STEERING SYSTEM 6-7</p> <p style="padding-left: 20px;">LIGHTS 6-7</p> <p style="padding-left: 20px;">FITTINGS/FASTENERS 6-8</p> <p style="padding-left: 20px;">SERVICE TOOLS AND SPARE PARTS 6-8</p> <p>OPERATION 7-1</p> <p style="padding-left: 20px;">STARTING THE ENGINE 7-1</p> <p style="padding-left: 20px;">EMERGENCY ENGINE STARTING 7-2</p> <p style="padding-left: 20px;">BREAK-IN 7-3</p> <p style="padding-left: 20px;">RIDING YOUR SNOWMOBILE GETTING TO KNOW YOUR SNOWMOBILE 7-4</p> <p style="padding-left: 20px;">LEARNING TO RIDE YOUR SNOWMOBILE 7-4</p> <p style="padding-left: 20px;">TO START OUT AND ACCELERATE 7-5</p> <p style="padding-left: 20px;">BRAKING 7-6</p> <p style="padding-left: 20px;">TURNING 7-6</p> <p style="padding-left: 20px;">RIDING UPHILL 7-7</p> <p style="padding-left: 20px;">RIDING DOWNHILL 7-8</p>
--	---

CROSSING A SLOPE (SIDE HILL)	7-9	STORAGE	10-1
ICE OR ICY SURFACE	7-10	RETURN TO SERVICE AFTER STORAGE	10-2
HARD-PACKED SNOW	7-10	SPECIFICATIONS	11-1
OPERATION ON SURFACES OTHER THAN SNOW OR ICE... ..	7-11	DIMENSIONS	11-1
DRIVING	7-12	ENGINE	11-1
STOPPING THE ENGINE	7-13	CHASSIS	11-2
TRANSPORTING	7-13	ELECTRIC	11-3
PERIODIC MAINTENANCE	8-1	WIRING DIAGRAM	12-1
MAINTENANCE CHART	8-1		
TOOL KIT	8-4		
SPARK PLUG INSPECTION	8-4		
ENGINE IDLE SPEED ADJUST- MENT	8-6		
THROTTLE CABLE ADJUSTMENT	8-7		
OIL PUMP CABLE ADJUSTMENT	8-7		
CARBURETOR ADJUSTMENT ..	8-8		
HIGH ALTITUDE ADJUSTMENTS	8-11		
DRIVE V-BELT REPLACEMENT	8-12		
DRIVE CHAIN HOUSING	8-13		
BRAKE/PARKING BRAKE	8-14		
SUSPENSION	8-15		
TRACK ADJUSTMENT	8-16		
SKI ALIGNMENT	8-20		
HANDLEBAR ADJUSTMENT ..	8-20		
LUBRICATION	8-21		
HEADLIGHT	8-21		
TROUBLESHOOTING	9-1		

YAMAHA MOTOR CORPORATION, U.S.A. SNOWMOBILE LIMITED WARRANTY

Yamaha Motor Corporation, U.S.A. hereby warrants that new Yamaha snowmobiles purchased from an authorized Yamaha snowmobile dealer in the continental United States will be free from defects in material and workmanship for the period of time stated herein, subject to certain stated limitations.

WARRANTY PERIOD:

1. All Yamaha snowmobiles shall be warranted for a term of one (1) year from the date of purchase, plus a special early-season extension (if applicable).
2. All Yamaha snowmobile clutch components are warranted against abnormal wear for one (1) year from the date of purchase, plus a special early-season extension (if applicable).

DURING THE PERIOD OF WARRANTY any authorized Yamaha snowmobile dealer will, free of charge, repair or replace, at Yamaha's option, any part adjudged defective by Yamaha due to faulty workmanship or material from the factory. Parts used in warranty repairs will be warranted for the balance of the snowmobile's warranty period. All parts replaced under warranty become the property of Yamaha Motor Corporation, U.S.A.

GENERAL EXCLUSIONS from this warranty shall include any failures to the machine caused by:

1. Competition, racing, or non-Yamaha authorized rental use.
2. Operation on surfaces other than snow or ice.
3. Installation of parts or accessories that are not qualitatively equivalent to genuine Yamaha parts.
4. Abnormal strain, neglect, or abuse.
5. Lack of proper maintenance.
6. Accident or collision damage.
7. Modification to original parts.

SPECIFIC EXCLUSIONS from this warranty shall include parts replaced due to normal wear or routine maintenance including oil, spark plugs, clutch drive belts, and slide runners.

THE CUSTOMER'S RESPONSIBILITY under this warranty shall be to:

1. Operate and maintain the snowmobile as specified in the appropriate Owner's Manual.
2. Give notice to an authorized

Yamaha snowmobile dealer of any and all apparent defects within ten (10) days after discovery, and make the machine available at that time for inspection and repairs at such dealer's place of business. You may locate your nearest authorized Yamaha dealer through your local telephone directory.

WARRANTY TRANSFER: To transfer any remaining warranty from the original purchaser to any subsequent purchaser, it is imperative that the machine be inspected and registered for warranty by an authorized Yamaha snowmobile dealer. In order for this warranty to remain in effect, this inspection and registration must take place within ten (10) days after ownership transfer. An inspection and registration fee will be charged for this service.

YAMAHA MOTOR CORPORATION, U.S.A. MAKES NO OTHER WARRANTY OF ANY KIND, EXPRESSED OR IMPLIED. ALL IMPLIED WARRANTIES OF MERCHANTABILITY AND FITNESS FOR A PARTICULAR PURPOSE WHICH EXCEED THE OBLIGATIONS AND TIME LIMITS STATED IN THIS WARRANTY ARE HEREBY DISCLAIMED BY YAMAHA MOTOR CORPORATION, U.S.A. AND EXCLUDED FROM THIS WARRANTY.

SOME STATES DO NOT ALLOW LIMITATIONS ON HOW LONG AN IMPLIED WARRANTY LASTS, SO THE ABOVE LIMITATION MAY NOT APPLY TO YOU. ALSO EXCLUDED FROM THIS WARRANTY ARE ANY INCIDENTAL OR CONSEQUENTIAL DAMAGES INCLUDING LOSS OF USE. SOME STATES DO NOT ALLOW THE EXCLUSION OR LIMITATION OF INCIDENTAL OR CONSEQUENTIAL DAMAGES, SO THE ABOVE EXCLUSION MAY NOT APPLY TO YOU.

THIS WARRANTY GIVES YOU SPECIFIC LEGAL RIGHTS, AND YOU MAY ALSO HAVE OTHER RIGHTS WHICH VARY FROM STATE TO STATE.

SPECIAL EARLY-SEASON WARRANTY EXTENSION

A special warranty extension is available for all new Yamaha snowmobiles purchased between June 1 and December 1.

All new Yamaha snowmobiles purchased between June 1 and December 1 will have the warranty extended to November 30 of the following year.

YAMAHA MOTOR CORPORATION, U.S.A.
Post Office Box 6555
Cypress, California 90630

WARRANTY QUESTIONS AND ANSWERS

- Q. What costs are my responsibility during the warranty period?
- A. The customer's responsibility includes all costs of normal maintenance services, non-warranty repairs, accident and collision damages, as well as oil, spark plugs, clutch drive belts, and slide runners.
- Q. What are some examples of "abnormal" strain, neglect, or abuse?
- A. These terms are general and overlap each other in areas. Specific examples include: Running the machine out of oil, hitting an object submerged under snow, operation on surfaces other than snow or ice, operating the machine with a broken or damaged part which causes another part to fail, and so on. If you have any specific questions on operation or maintenance, please contact your dealer for advice.
- Q. May I perform any or all of the recommended maintenance shown in the Owner's Manual instead of having the dealer do them?
- A. Yes, if you are a qualified snowmobile mechanic and follow the procedures specified in the Owner's and Service Manual. We do recommend, however, that items requiring special tools or equipment be done by a Yamaha snowmobile dealer.
- Q. Under what conditions is the clutch not covered by warranty?
- A. Clutches as well as clutch components wear with use. Normal wear is not covered under warranty such service is the customer's responsibility. Abnormal wear is, however, covered for one (1) year from the date of purchase. Your Yamaha snowmobile dealer possesses criteria as to what constitutes abnormal wear.

- Q. Will the warranty be void or cancelled if I do not operate or maintain my new Yamaha exactly as specified in the Owner's Manual?
- A. No. The warranty on a new Yamaha cannot be "voided" or "cancelled." However, if a particular failure is caused by operation or maintenance other than as shown in the Owner's Manual, that failure may not be covered under warranty.
- Q. What responsibility does my dealer have under this warranty?
- A. Each Yamaha snowmobile dealer is expected to:
1. Completely set up every new machine before sale.
 2. Explain the operation, maintenance, and warranty requirements to your satisfaction at the time of sale, and upon your request at any later date.
 3. In addition, each Yamaha snowmobile dealer is held responsible for his setup, service and warranty repair work.
- Q. Whom should I contact if I have further questions about this warranty?
- A. Your Yamaha snowmobile dealer has the information and experience necessary to answer almost any questions about this warranty. If the dealer is not able to do so, he is expected to contact Yamaha Motor Corporation, U.S.A., for clarification or assistance.

CUSTOMER SERVICE

If your machine requires warranty service, you must take it to any authorized Yamaha snowmobile dealer within the continental United States. Be sure to bring your warranty identification card or other valid proof of the original date of purchase. If a question or problem arises regarding warranty, first contact the owner of the dealership. Since all warranty matters are handled at the dealer level, this person is in the best position to help you. If you are still not satisfied and require additional assistance, please write:

YAMAHA MOTOR CORPORATION
U.S.A.
CUSTOMER RELATIONS DEPARTMENT
P.O. Box 6555
Cypress, California 90630

When contacting Yamaha Motor Corporation, U.S.A. be sure to include the model, serial number, names, dates, and receipts.

CHANGE OF ADDRESS

The federal government requires each manufacturer of a motor vehicle to maintain a complete, up-to-date list of all first purchasers against the possibility of a safety-related defect and recall. This list is compiled from the purchase registrations sent to Yamaha Motor Corporation, U.S.A. by the selling dealer at the time of your purchase.

If you should move after you have purchased your new snowmobile, please advise us of your new address by sending a postcard listing your snowmobile model name, engine serial number, dealer number (or dealer's name) as it is shown on your warranty registration identification, your name and new mailing address. Mail to:

**YAMAHA MOTOR CORPORATION,
U.S.A.
WARRANTY DEPARTMENT
P.O. Box 6555
Cypress, California 90630**

This will ensure that Yamaha Motor Corporation, U.S.A. has an up-to-date registration record in accordance with federal law.

YAMAHA EXTENDED SERVICE (Y.E.S.)

Keep your Yamaha protected even after your warranty expires with genuine Yamaha Extended Service (Y.E.S.).

- Y.E.S. is designed and administered by Yamaha Motor Corporation to provide maximum owner satisfaction. You get uninterrupted factory-backed coverage for extra peace of mind.
- Y.E.S. is flexible. You choose the plan that's right for you: 12 months, 24 months, or 36 months beyond your warranty period.
- Y.E.S. is designed and administered by the same Yamaha people who handle your warranty — and it shows in the comprehensive coverage benefits. There are no mileage limitations. Coverage isn't limited to "moving parts" or the "drive train" like many other plans. And Y.E.S. covers manufacturing defects just like the warranty. See the sample contract at your Yamaha dealer to see how comforting uninterrupted factory-backed protection can be.
- You don't have to pay anything for covered repairs. There's no deductible to pay, and repairs aren't "pro-rated." You don't have any "out-of-pocket" expenses for covered repairs.
- In addition, Travel and Recreation Interruption Protection (TRIP) is included at no extra cost. TRIP gives you up to \$150 reimbursement per occurrence for any reasonable expenses you incur because your Yamaha needs covered service: replacement vehicle rental, emergency towing, phone calls, even food and lodging when you are away from home. This superb coverage goes into effect when you purchase Y.E.S., so it applies to any warranty repairs as well as covered repairs during your entire Y.E.S. plan period.
- Y.E.S. coverage is honored at any authorized Yamaha dealer nationwide.
- Y.E.S. coverage is transferrable to a new owner if you sell or trade-in. That can make your Yamaha much more valuable!

This excellent Y.E.S. plan coverage is only available to Yamaha owners like you, and only while your Yamaha is still within the Yamaha Limited Warranty period. So visit your authorized Yamaha dealer to get all the facts. He can show you how easy it is to protect your investment with Yamaha Extended Service.

We urge you to act now. You'll get the excellent benefits of TRIP coverage right away, and you'll rest easy knowing you'll have strong factory-backed protection even after your Yamaha Limited Warranty expires. You can also save money: Y.E.S. costs less within the first 90 days after you buy your Yamaha. See your dealer today!

A special note:

If visiting your dealer isn't convenient, contact Yamaha with your Primary ID number (your engine number). We'll be happy to help you get the Y.E.S. coverage you need.

Yamaha Service Marketing P.O.Box 6555
Cypress, CA 90630
(714) 761-7631



ESB01500

LOCATION OF THE IMPORTANT LABELS

Please read the following labels carefully before operating this machine.

NOTE: _____
Maintain or replace safety and instruction labels, as necessary.

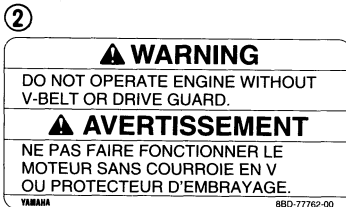
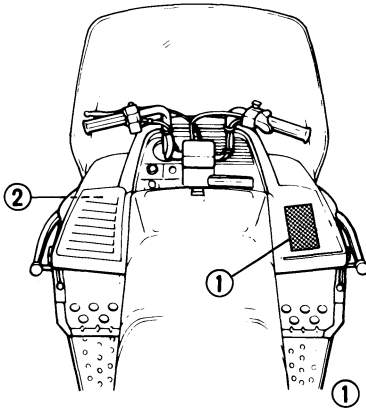

⚠ WARNING

SEVERE INJURY OR DEATH MAY RESULT IF YOU IGNORE ANY OF THE FOLLOWING:

- Read the Owner's Manual and all labels before operating this vehicle.
- Check throttle, brake, and steering for proper operation before starting engine.
- Set parking brake before attempting to start engine. Never run this vehicle with the parking brake applied.
- To stop engine in an emergency, push the engine stop switch down.
- Do not operate engine without drive belt or drive guard.
- Make sure the fuel tank cap is closed securely after refueling.
- Do not operate this vehicle on public roads. You could collide with another vehicle.
- This vehicle is designed for operator only – no passengers.
- Wear an approved helmet, eye protection, and adequate clothing for snowmobiling.

⚠ AVERTISSEMENT

AFIN D'ÉVITER TOUT RISQUE DE BLESSURE SÉRIEUSE OU MÊME MORTELLE, VEUILLEZ SUIVRE LES RECOMMANDATIONS SUIVANTES:

- Avant d'utiliser ce véhicule, lire le manuel du propriétaire et toutes les étiquettes.
- Avant de démarrer le moteur, vérifier l'opération du frein, de l'accélérateur et de la direction.
- Le frein de sécurité doit être appliqué lors du démarrage. Ne pas rouler avec le frein de sécurité actionné.
- En cas d'urgence, utiliser l'interrupteur d'arrêt du moteur.
- Ne pas laisser tourner le moteur sans la courroie ou sans son garde.
- S'assurer que le bouchon du réservoir soit bien refermé après le remplissage.
- Afin d'éviter tout risque de collision, ne pas rouler sur un chemin public.
- Ce véhicule est conçu pour un conducteur seul – aucun passager.
- Toujours porter un casque approuvé et un habillement de motoneigiste. Prévoir une protection pour les yeux.

87S-77761-10

SAFETY INFORMATION

When you ride your snowmobile, you must know and use the following for your safety. Severe injury or death may result if you ignore any of the following.

Before Operating

1. Read the Owner's Manual and all labels before operating this machine. Become familiar with all of the operating controls and their function. Consult a Yamaha dealer about any control or function you do not understand.
2. This machine was not manufactured for use on public streets, roads, or highways. Such use is prohibited by law, and you could collide with another vehicle.
3. This machine is designed to carry the OPERATOR ONLY. Passengers are prohibited. Carrying a passenger can cause loss of control.
4. Do not operate the machine after drinking alcohol or taking drugs. Your ability to operate the machine is reduced by the influence of alcohol or drugs.

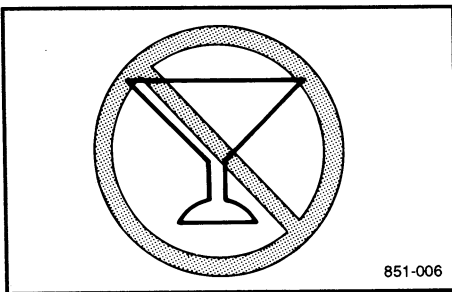
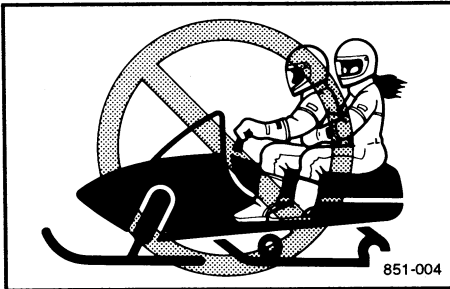
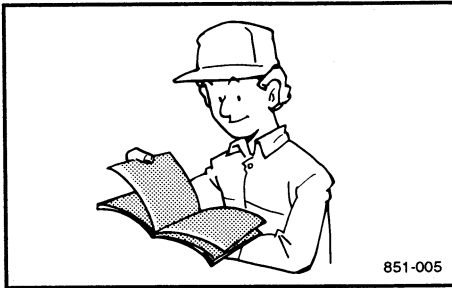

5. For safety and proper care of the machine, always perform the Pre-Operation Checks on page 6-1 ~ 6-8 before starting the engine. Check the throttle, steering and brake operation every time before starting the engine. Be sure the throttle lever moves freely and it returns to the idle position when it is released.

6. Apply the parking brake before starting the engine. Never drive the machine with the parking brake applied. This may overheat the brake disc and reduce braking ability.

7. Do not allow anyone to stand behind the machine when starting, inspecting or adjusting the machine. A broken track, track fittings or debris thrown by the track could be dangerous to the operator or bystanders.

8. Handle fuel with care; it is highly flammable.

- Never add fuel when the engine is running or hot.

Allow the engine to cool for several minutes after running.

- Use an approved fuel container.
- Fill the fuel tank outdoors with extreme care. Never remove the fuel cap indoors. Never fill the fuel tank indoors.

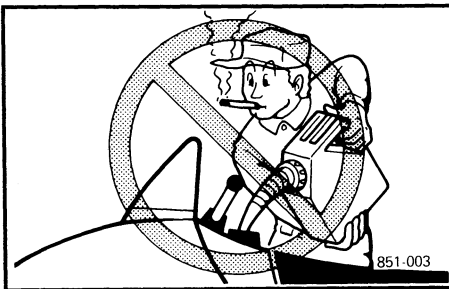

- Never refuel while smoking or in the vicinity of an open flame.
- Make sure the fuel tank cap is closed securely after refueling. Wipe up any spilled fuel immediately.

9. If you swallow some gasoline, inhale a lot of gasoline vapor, or get some gasoline into your eye(s), see your doctor immediately. If any gasoline spills on your skin or clothing, immediately wash your skin with soap and water, and change your clothes.

10. Wear protective clothing. Wear an approved helmet, and a face shield or goggles. Also, wear a good quality snowmobile suit, boots, and a pair of snowmobile gloves or mittens that will permit use of your thumbs and fingers for operation of the controls.

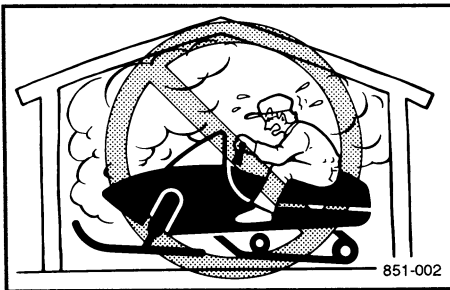
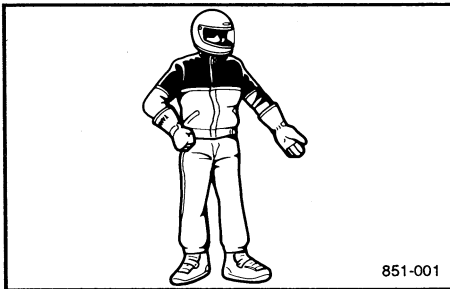

Operation

1. Do not run the engine indoors, except when starting the engine to transport the machine in or out of the building. Open the outside doors; exhaust fumes are dangerous.

2. Be careful where you ride. There may be obstacles hidden beneath the snow. Stay on established trails to minimize your exposure to hazards. Ride slowly and cautiously when you ride off of established trails. Hitting a rock or stump, or running into wires could cause an accident and injury.
3. This machine is not designed for use on surfaces other than snow or ice. Use on dirt, sand, grass, rocks, or bare pavement may cause loss of control and may damage the machine.
4. Avoid operating on glare ice, or on snow which has a lot of dirt or sand mixed in. Operation under such conditions will damage or result in rapid wear of ski runners, drive track, slide runners and drive sprockets.
5. Always have other snowmobilers with you when going on a ride. You may need help if you run out of fuel, have an accident, or damage your snowmobile.
6. Many surfaces such as ice and hard-packed snow require much longer stopping distances. Be alert, plan ahead and begin decelerating early. The best braking method on most surfaces is to release the throttle and apply the brake gently – not suddenly.

Maintenance and Storage

1. Modifications made to the machine not approved by Yamaha, or the removal of original equipment may render your machine unsafe for use and may cause severe personal injury. Modifications may also make your machine illegal to use.
2. Never store the machine with fuel in the fuel tank inside a building where ignition sources are present such as hot water and space heaters, open flame, spark, clothes dryers, and the like. Allow the engine to cool before storing in any enclosure.
3. Always refer to "STORAGE" for important details if the machine is to be stored for an extended period.
4. Maintain or replace safety and instruction labels, as necessary.

DESCRIPTION

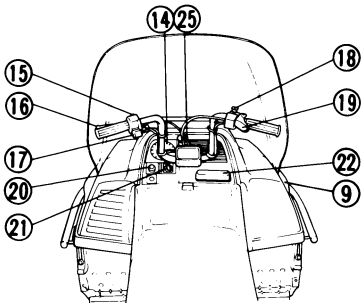
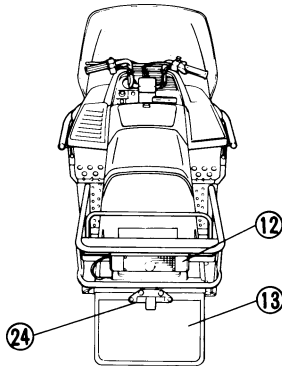
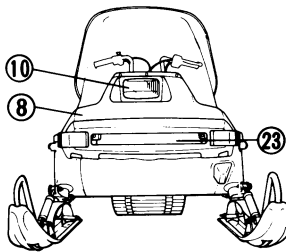
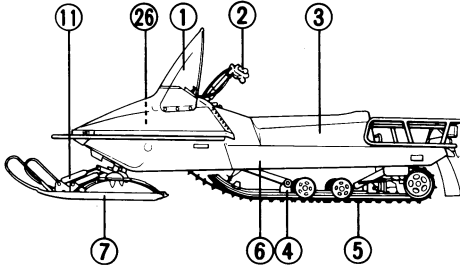

- ① Windshield
- ② Steering handlebar
- ③ Seat
- ④ Slide rail suspension
- ⑤ Drive track
- ⑥ Frame
- ⑦ Steering ski
- ⑧ Shroud
- ⑨ Shroud latch
- ⑩ Headlight
- ⑪ Ski damper
- ⑫ Taillight
- ⑬ Flap
- ⑭ Speedometer
- ⑮ Parking brake button
- ⑯ Brake lever
- ⑰ Headlight beam switch
- ⑱ Engine stop switch
- ⑲ Throttle lever
- ⑳ Main switch
- ㉑ Starter lever
- ㉒ Starter handle
- ㉓ Front baffle plate
- ㉔ Tow hitch
- ㉕ Primer pump knob
- ㉖ Fuel cock lever

ESG05000

CONTROL FUNCTIONS

ESS21501

MAIN SWITCH

The main switch controls the following items.

① OFF:

Ignition circuit is switched off.

The key can be removed only in this position.

② ON:

Ignition circuit is switched on.

The engine can be started.

NOTE: _____

The lights will come on after the engine starts.

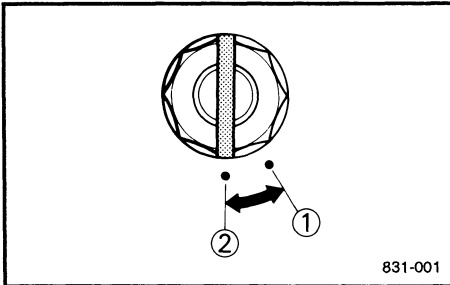

ESS22100

STARTER LEVER (CHOKE)

Use this lever when starting and warming up a cold engine.

① Starter lever (choke)

② When starting a cold engine.

③ When the engine is warm.

NOTE: _____

Refer to "Starting the engine" for proper operation.

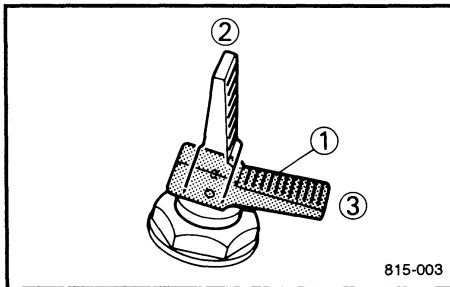

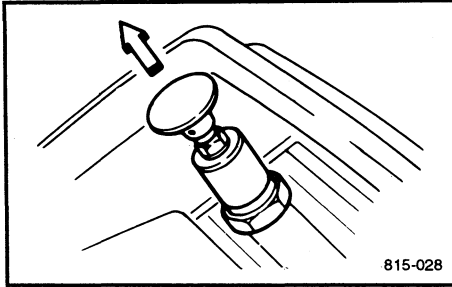

ESS22500

PRIMER PUMP KNOB

Pump the knob several times in low temperatures for easier engine starting.

CAUTION:

Excessive use of the primer knob may flood the engine with fuel.

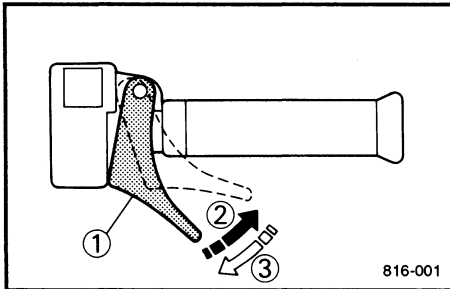

ESS21600

THROTTLE LEVER

Once the engine is running cleanly, squeezing ② of the throttle lever ① will increase the engine speed and cause engagement of the drive system. Regulate the speed of the machine by varying the throttle position. Because the throttle is spring-loaded, the machine will decelerate, and the engine will return to an idle when the thumb is released ③.

⚠ WARNING

Check throttle, brake, and steering for proper operation before starting engine.

ESS22300

THROTTLE OVERRIDE SYSTEM (T.O.R.S.)

If the carburetor or throttle cable should malfunction during operation, release the throttle lever. The T.O.R.S. is designed to interrupt the ignition and stop the engine if the carburetor fails to return to idle when the lever is released.

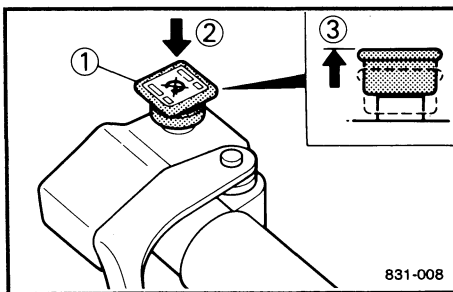
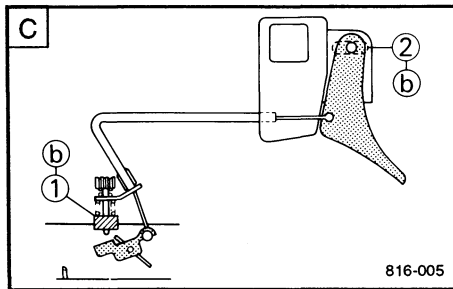
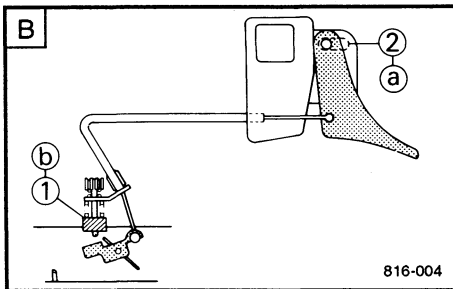
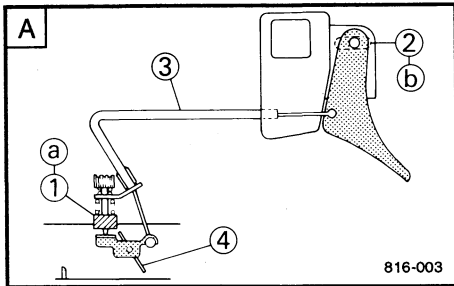

⚠ WARNING

If T.O.R.S. stops the engine, make sure that the cause of the malfunction has been corrected and that the engine can be operated without a problem before restarting the engine.

MODE \ SWITCH	A Idle or Starting	B Run	C Trouble
Carburetor switch	ON	OFF	OFF
Throttle switch	OFF	ON	OFF
Engine	RUN	RUN	STOP

- ① Carburetor switch
- ② Throttle switch
- ③ Throttle cable
- ④ Throttle valve
- a "ON"
- b "OFF"
- A Idle or starting
- B Run
- C Trouble

ESS20800

ENGINE STOP SWITCH

The engine stop switch ① is used to stall the engine in an emergency. Simply push ② the engine stop switch, and the engine will stop. To start the engine, pull ③ the engine stop switch and see page 7-1 for more details. During the first few rides, you should practice using the switch while driving so that you can react quickly in an emergency.

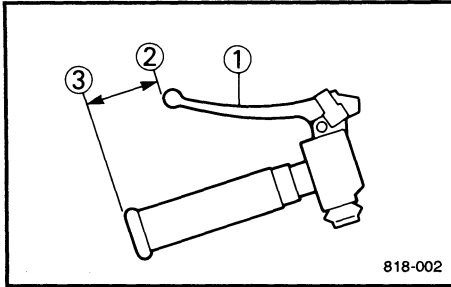

ESS28100

BRAKE LEVER

The machine is stopped by braking the entire drive system.

Squeeze the brake lever towards the handlebar to stop the machine.

- ① Brake lever
- ② Brake lever end
- ③ Handlebar end

NOTE:

When the brake is operated, the brake light will illuminate.

CAUTION:

Be sure the brake lever end does not project out over the handlebar end. This will help prevent brake lever damage when the machine is placed on its side for service.

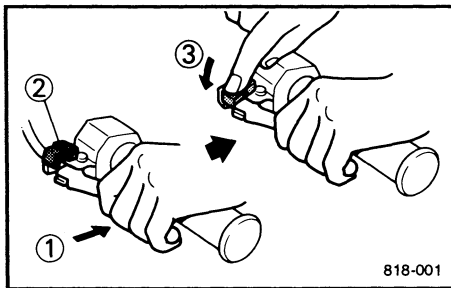

ESS28200

PARKING BRAKE BUTTON

When parking the machine or starting the engine, apply the parking brake.

Squeeze the brake lever ①, then push down ③ the parking brake button ② while releasing the brake lever.

To release the parking brake, just squeeze the brake lever.

⚠ WARNING

- Always set the parking brake before attempting to start the engine.
- Never run the machine with the parking brake applied.
This may overheat the brake disc and reduce braking ability.

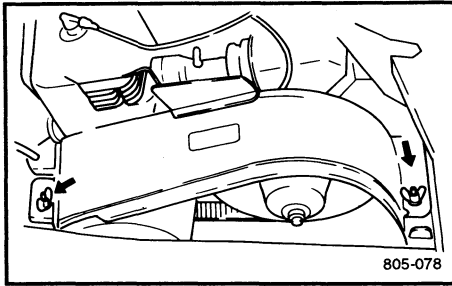

ESS28700

V-BELT GUARD

The V-belt guard is designed to cover the clutch and V-belt in case parts break or come loose.

⚠ WARNING

- Be sure the V-belt guard is tightened securely before operating the machine.
- Never run the engine without the V-belt or with the V-belt guard removed.

ESS29100

SHROUD LATCH

To open the shroud, unhook the latch, then slowly raise the shroud forward until it stops. When closing the shroud, slowly lower it to its home position, then hook the shroud latches.

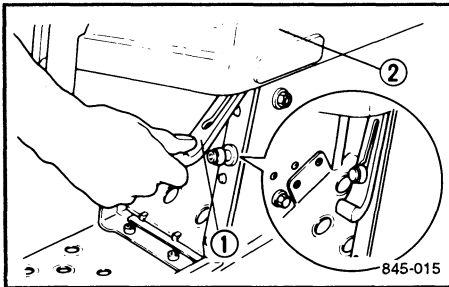

- ① Latch
- ② Shroud

CAUTION:

Be sure all cables and wires are in place when closing the shroud.

⚠ WARNING

- Do not drive the machine with the shroud open or unlatched or with the shroud removed.
- Keep your body and clothing away from rotating parts when servicing with the shroud open.
- Do not touch the hot muffler and engine during or immediately after operation.

ESS23802

ENGINE ROOM PLATE

Open the plate to cool down the engine.

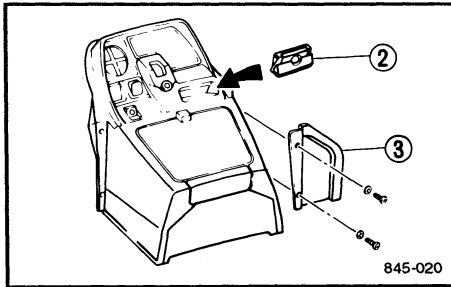
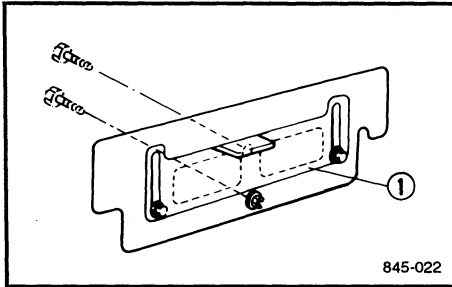
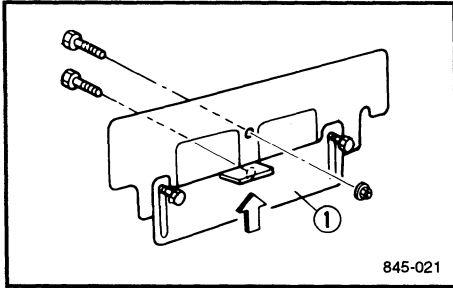

CAUTION:

- Close the baffle plate ①, install the recoil seal ② and side plate ③ when operating the machine in deep powder snow.
- Open the baffle plate, remove the recoil seal and side plate when ambient temperature is above 0°C (32°F)

ESS09100

FUEL TANKS

This machine is equipped with two fuel tanks; main tank ① in the engine room and sub-tank ② under the instrument panel.

Always add fuel to each of the tanks.
See page 6-1 ~ 6-2 for details.

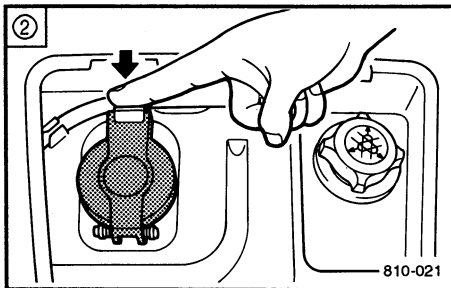
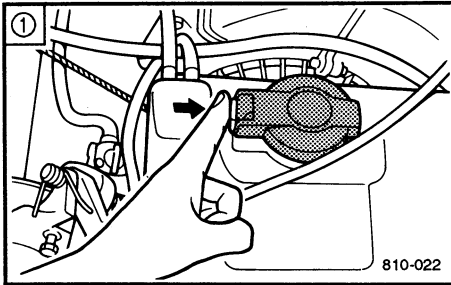

ESS07401

FUEL COCK LEVER

The fuel cock lever controls the fuel lines.

- ① OFF: With the lever in this position, fuel does not flow. The engine can not be started.
- ② ON: In this position, fuel flows from the main tank to the carburetor. The engine can be started and operated. The lever should usually be kept in the "ON" position while operating the machine.

- ③ RES: In this position, fuel flows from the sub-tank to the carburetor. The machine can be operated for a short time.

If the machine runs out of fuel in the "ON" position, turn the lever to the "RES" position.

Remember to fill both main and sub fuel tanks at the first opportunity.

After refueling, return the lever to the "ON" position.

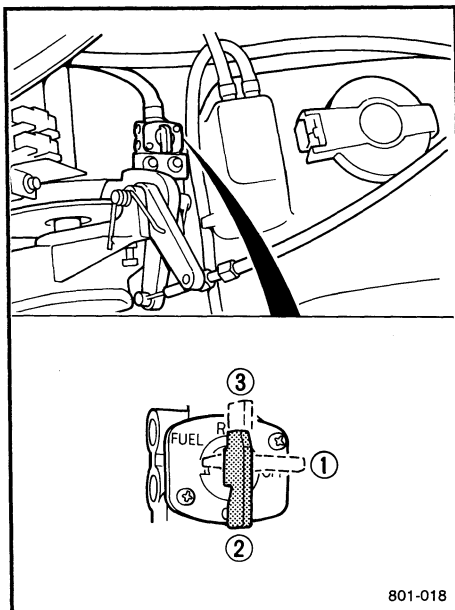

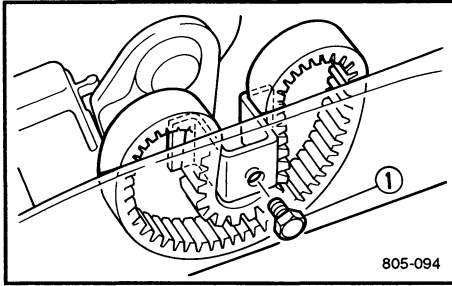

ESS08101

V-BELT HOLDER

Keep a spare V-belt in the holder provided for emergency use.

NOTE: _____
Loosen the bolt ① to remove the V-belt.

CAUTION:

- Be sure to tighten the bolt when installing the V-belt in the holder.
- Be sure the fuel hose is not pinched and is in place when installing the V-belt.

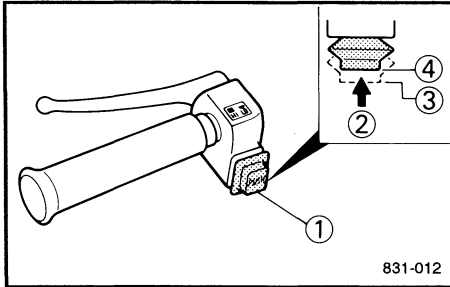

ESS28300

HEADLIGHT BEAM SWITCH

Push the switch to change the head light beam alternately to high or low.

- ① Headlight beam switch
- ② Push
- ③ High beam
- ④ Low beam

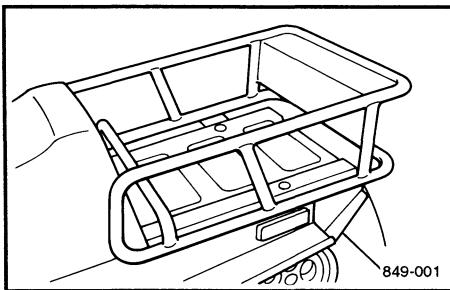

ESS08600

REAR CARRIER

<p>Maximum load limit: 20 kg (44 lbs)</p>

ESS27400

TOW HITCH

Use the tow point within the specified weight limits.

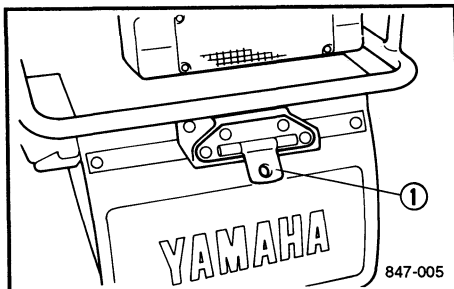

① Tow point

Tow weight	120 kg (265 lb)
Vertical weight	15 kg (33.1 lb)

CAUTION

Avoid towing for a long time under the 10 km/h (0.6 mi/h) speed to prevent early wear of the drive V-belt.

ESB30000

PRE-OPERATION CHECKS

NOTE: _____
Pre-operation checks should be made each time the machine is used.

⚠ WARNING _____

The engine and muffler will be very hot after the engine has been run. Avoid touching the engine and muffler while they are still hot with any part of your body or clothing during inspection or repair.

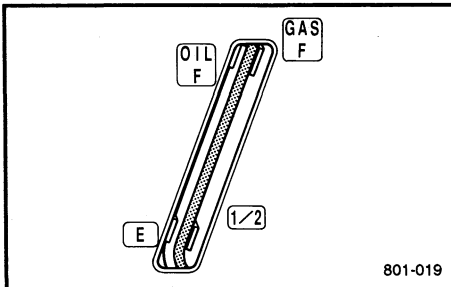

ESS30102

FUEL

Make sure there is sufficient fuel in both main and sub tanks.

Recommended fuel:

Unleaded gasoline
Pump Octane R+M ; 88
2

Fuel tank capacity:

- ① Main tank:
15 L (3.3 Imp gal, 4.0 US gal)
- ② Sub tank:
9.3 L (2.05 Imp gal, 2.46 US gal)

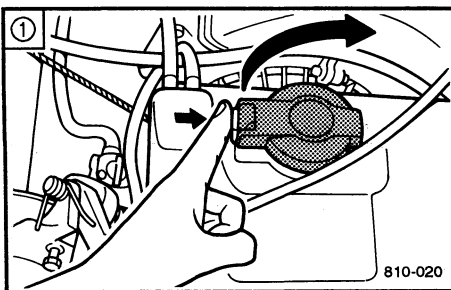

⚠ WARNING _____

- Fuel is highly flammable and poisonous. Check "SAFETY INFORMATION" (See page 3-2) carefully before refueling.

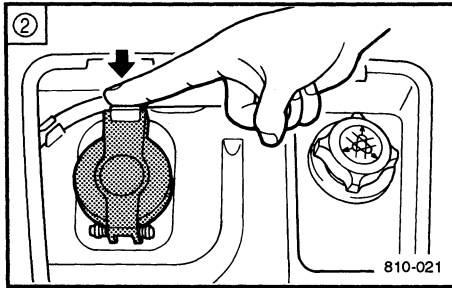

- Make sure that the fuel tank cap is closed securely after refueling. Leaking fuel can catch fire.
 - Do not fill the fuel tank all the way to the top. When the machine is tilted, this could cause the fuel to overflow.
-

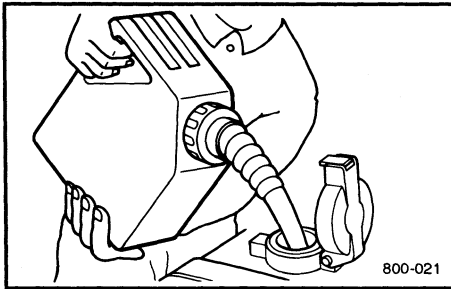

CAUTION:

- Oxygenated fuels (“gasohol”) containing max. 5% of ethanol can be used, although richer jetting may be required to prevent engine damage. Consult a Yamaha dealer. Gasohol containing methanol is not recommended.
 - Be sure that snow and/or ice does not enter into the fuel tank when refueling.
 - Do not use alcohol deicers or water absorbing additives with oxygenated fuel.
 - The tank should be filled with straight gasoline as specified.
-

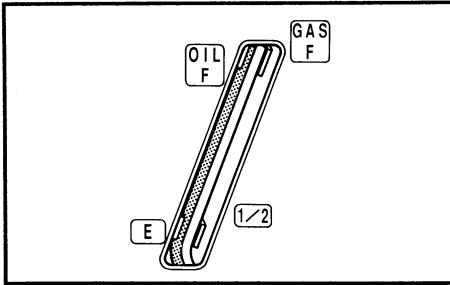

*ESS33000

ENGINE OIL

Make sure there is sufficient oil in the oil tank.

Oil tank capacity:
 1.8 L (1.6 Imp qt, 1.9 US qt)
 Recommended oil:
 YAMALUBE 2-cycle oil

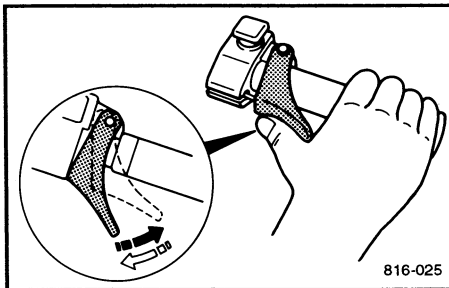
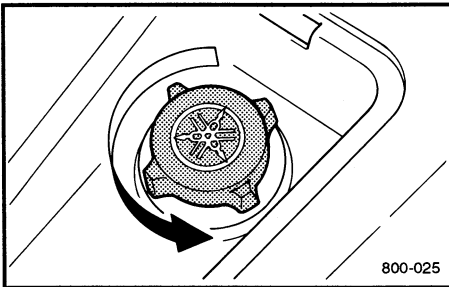

ESS31500

THROTTLE LEVER

Check the throttle lever operation before starting the engine. It must open smoothly and spring back to idle when released.

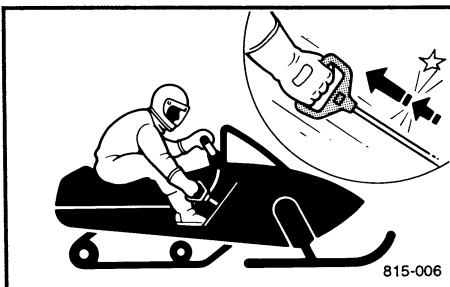

ESS31200

MANUAL STARTER

Check for proper operation. Check the rope for damage.

ESS31300

THROTTLE OVERRIDE SYSTEM (T.O.R.S.) CHECK

⚠ WARNING

When checking T.O.R.S.:

- Be sure the parking brake is applied.
- Be sure the throttle lever moves smoothly.
- Do not run the engine up to clutch engagement rpm. Otherwise, the machine could start moving forward unexpectedly, which could cause an accident.

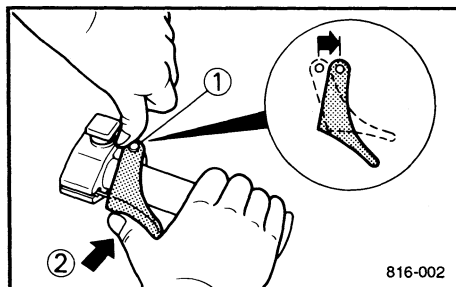
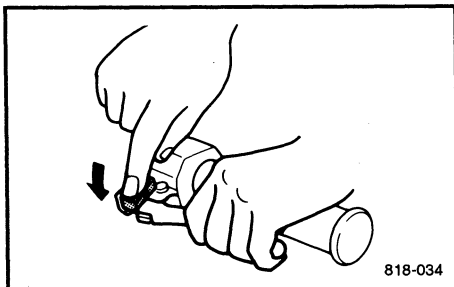

1. Start the engine.

NOTE:

Refer to STARTING THE ENGINE.

2. Hold the pivot point of the throttle lever away from the throttle switch ①.
3. Press ② the throttle lever gradually. The engine should stop immediately.

⚠ WARNING

If the engine does not stop, stop the engine by turning the main switch to "OFF" position and consult a Yamaha dealer.

ESS31900

BRAKE

(See page 8-14 for more details)

Test the brake at slow speed when starting out to make sure it is working properly. If the brake does not provide proper braking performance, inspect the brake for wear.

⚠ WARNING

Do not operate the machine if you find any problem with the brake. You could lose braking ability, which could lead to an accident.

CAUTION:

Be sure the brake lever end should not project out over the handlebar end for preventing brake lever damage when the machine is placed on its side.

ESS31800

V-BELT

Open the shroud and remove the V-belt guard.

Check V-belt wear and damage. Replace if necessary.

Wear limit ①: 28.0 mm (1.10 in)

⚠ WARNING

- **Be sure the V-belt guard is tightened securely before operating the machine.**
- **Never run the engine without the V-belt or with the V-belt guard removed.**

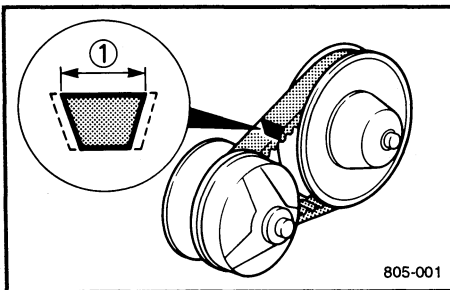

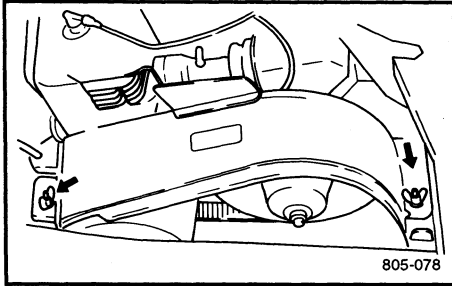

ESS32400

DRIVE V-BELT GUARD

Check the drive belt guard mounts for damage, and check the tightness of the wing bolt. Make sure the drive belt guard is firmly in place.

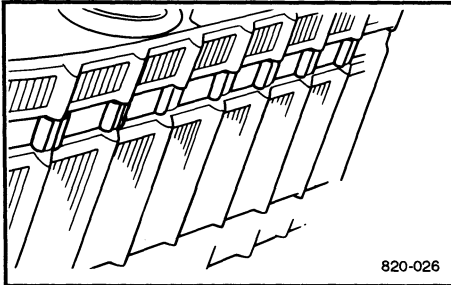

ESS34000

DRIVE TRACK

(See page 8-16 ~ 8-19 for more details)

Check the drive track for deflection, wear and damage.

Adjust/replace if necessary.

⚠ WARNING

Do not operate the machine if you find damage to the drive track, or misadjustment. Drive track damage and/or failure could result in loss of braking ability and machine control, which could cause an accident.

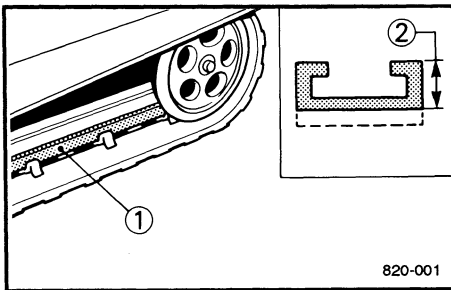

ESS32200

SLIDE RUNNERS

Check wear and damage.

If the slide runners reach the wear limit, they should be replaced.

- ① Slide runners
- ② Wear limit

Wear limit height:
10 mm (0.39 in)

CAUTION

Be sure to ride on the fresh snow frequently to avoid rapid wear of slide runner when operating on ice or hard packed snow.

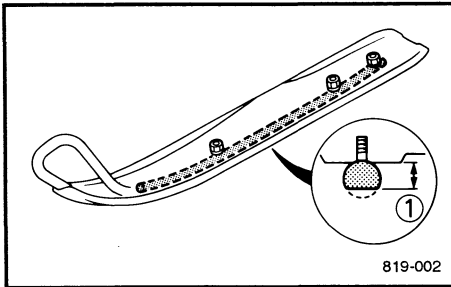

ESS32300

SKI/SKI RUNNER

Check wear and damage.
Replace if necessary.

Ski runner wear limit ①:
4.5 mm (0.18 in)

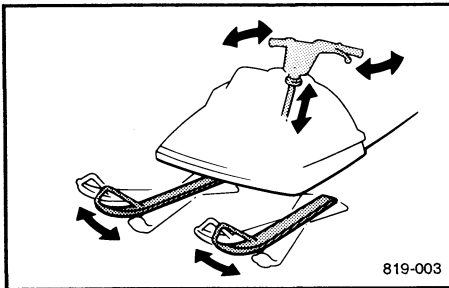

ESS34800

STEERING SYSTEM

1. Check the following for excessive free play:
 - 1) Push the handlebar up and down and back and forth.
 - 2) Turn the handlebar slightly to the right and left.
2. If excessive free play is noticed, consult a Yamaha dealer.

ESS36300

LIGHTS

Check the lights.
Replace any burned out bulbs.

ESL34600

FITTINGS/FASTENERS

Check the tightness of fittings/fasteners.

Tighten in proper sequence and torque if necessary.

ESS36800

SERVICE TOOLS AND SPARE PARTS

It is a good practice to carry service tools and spare parts with your machine so that minor repairs can be done by yourself. The following should be carried with you.

- Tool kit
- Flashlight
- Roll of plastic tape
- Steel wire
- Tow rope
- Emergency starter rope

In addition to these, it is advisable to have the following spare parts:

- Drive belt
- Light bulbs
- Spark plugs

When you start out for a long distance trip, extra fuel and oil should be carried.

ESG40100

OPERATION

ESS47501

STARTING THE ENGINE

⚠ WARNING

- Be sure to check "SAFETY INFORMATION" carefully before starting the engine.
- Be sure the parking brake is applied.

NOTE:

Be sure the engine stop switch and the fuel cock lever are in the "ON" position.

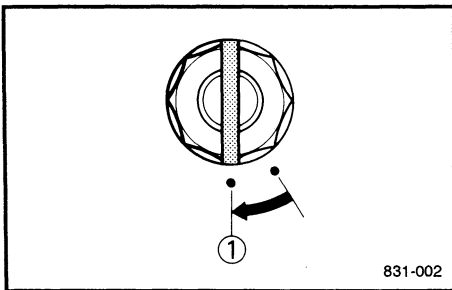
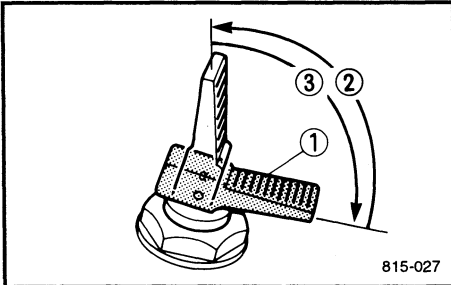
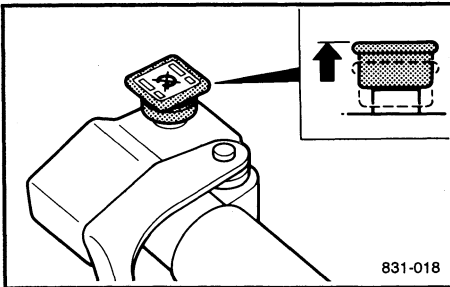
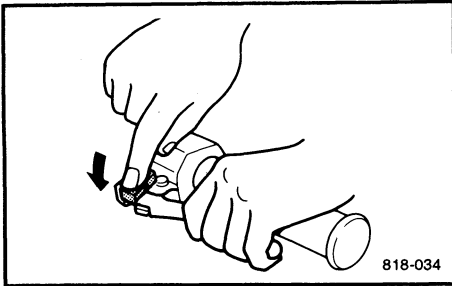

1. Fully open the starter lever. (Choke)

- ① Starter lever (Choke)
- ② Fully open (Cold engine starting)
- ③ Close (Warm engine starting)

NOTE:

The starter lever (choke) is not required when the engine is warm. Put the starter lever in the "Close" position.

2. Turn the main switch to the "ON" position.

- ① "ON"

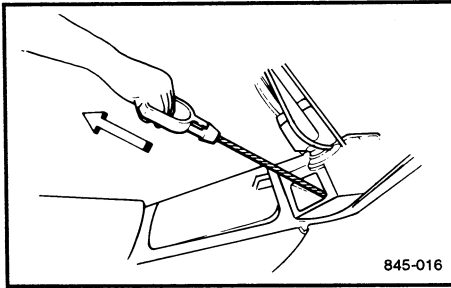

845-016

3. Pull slowly on the recoil starter until it is engaged, then pull it briskly. After the engine starts, warm up the engine until it does not run roughly or begin to stall when the starter lever is returned to the "Close" position.

ESS43401

EMERGENCY ENGINE STARTING

NOTE: _____

The emergency starter rope is supplied in the tool kit box at the factory.

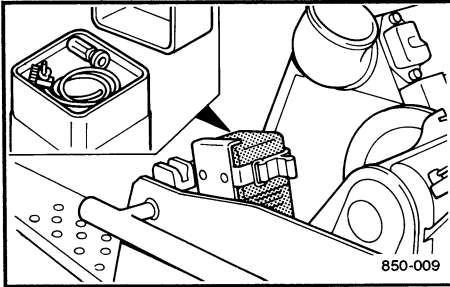

850-009

If the recoil starter system should fail, take the emergency starter rope out of the tool kit box and proceed as follows.

1. Proceed with the "STARTING THE ENGINE" item 1 and 2.

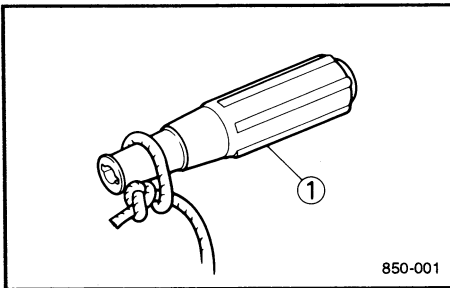

850-001

2. Tighten the emergency starter rope on the screwdriver handle.

① Screwdriver handle

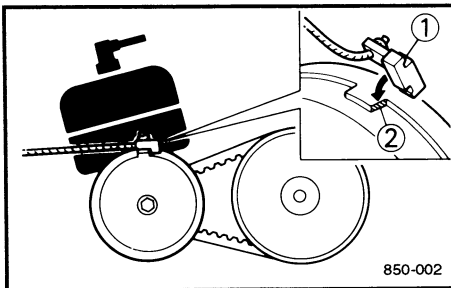

850-002

3. Mesh the rope stopper with the primary sheave edge.

① Rope stopper

② Primary sheave edge

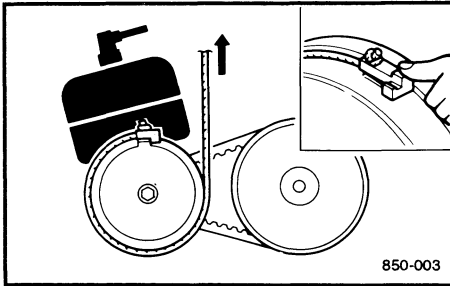

4. Wind the rope 3-counterclockwise turns on the primary sheave.

5. Grasp the screwdriver handle and pull briskly.

⚠ WARNING

Do not wind the emergency starter rope around your hand.

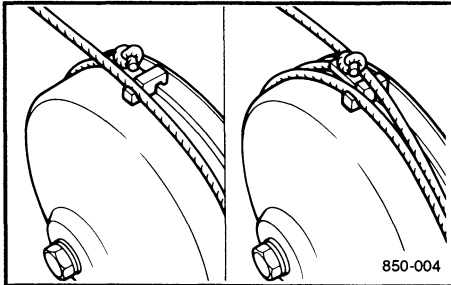

6. After the engine starts, warm up the engine until the engine does not stop when the starter lever is returned to "Close" position.

7. Install the drive guard and shroud.

⚠ WARNING

Avoid contact with the moving primary sheave.

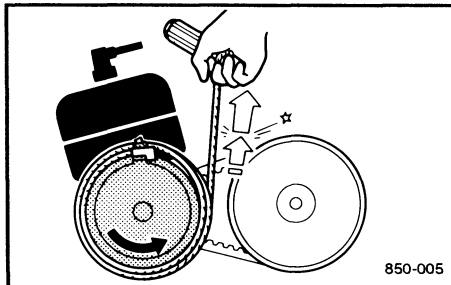

ESS41500

BREAK-IN

There is never a more important period in the life of your machine than the Break-In period. For the first 10 hours, approximately 200 km (125 miles), do not put an excessive load on the engine. Avoid prolonged full throttle operation. Also avoid lugging the engine, such as laborious operation in wet snow. If any abnormal condition is noticed, such as excessive vibration or noise, consult a Yamaha dealer.

RIDING YOUR SNOWMOBILE

GETTING TO KNOW YOUR SNOWMOBILE

A snowmobile is a rider active vehicle, and your riding position and your balance are the two basic factors of maneuvering your snowmobile.

Riding your snowmobile requires skills acquired through practice over a period of time. Take the time to learn the basic techniques well before attempting more difficult maneuvers.

Riding your new snowmobile can be a very enjoyable activity, providing you with hours of pleasure. But it is essential to familiarize yourself with the operation of the snowmobile to achieve the skill necessary to enjoy riding safely. Before you begin to ride, be sure you have read this Owner's Manual completely and understand the operation of the controls.

Pay particular attention to the safety information on page 3-1 ~ 3-5.

Please read all warning and caution labels on your snowmobile. Also read the Snowmobiler's Safety Handbook originally supplied with your machine.

LEARNING TO RIDE YOUR SNOWMOBILE

Before you ride, always perform the Preoperation checks listed on page 8-1 ~ 8-3. The short time spent checking the condition of the machine will be rewarded with added safety and a more

reliable snowmobile. Always wear the proper clothing for both warmth and to help protect you from injury if an accident occurs.

Become familiar with this snowmobile at slow speeds, even if you are an experienced operator. Do not attempt to operate at maximum performance until you are totally familiar with the machine's handling and performance characteristics.

The beginning operator should select a large, flat area to become familiar with the snowmobile. Make sure that this area is free of obstacles and other traffic. You should practice control of the throttle and brake, and master turning techniques in this area before trying more difficult terrain.

Set the parking brake and follow the instructions on page 7-1 ~ 7-2 to start the engine. Once it has warmed up, you are ready to begin riding your Snowmobile.

TO START OUT AND ACCELERATE

1. With the engine idling, release the parking brake.
2. Apply the throttle slowly and smoothly. The centrifugal clutch will engage and you will start to accelerate.

⚠ WARNING

The operator should always keep both hands on the handlebars. Never put your feet outside the running boards. Avoid higher speeds until you have become thoroughly familiar with your Snowmobile and all of its controls.

BRAKING

When slowing down or stopping, release the throttle and apply the brake gently-not suddenly.

⚠ WARNING

Many surfaces such as ice and hard packed snow require much longer stopping distances. Be alert, plan ahead and begin decelerating early. Improper use of the brake can cause the drive track to lose traction, reducing control and increasing the possibility of an accident.

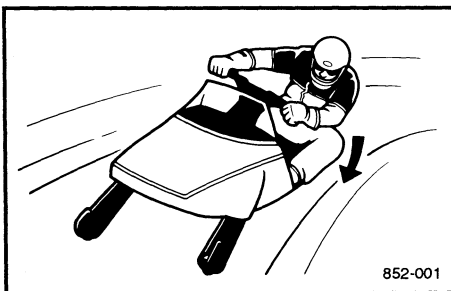

TURNING

For most snow surfaces, “body english” is the key to turning.

As you approach a curve, slow down and begin to turn the handlebars in the desired direction. As you do so, put your weight on the running board to the inside of the turn and lean your upper body into the turn.

This procedure should be practiced at slow speed many times in a large flat area with no obstacles. Once you have learned this technique, you should be able to perform it at higher speeds or in tighter curves. Lean more as the turn gets sharper or is made at higher speeds.

Improper riding procedures such as abrupt throttle changes, excessive braking, incorrect body movements, or too much speed for the sharpness of the turn may cause the snowmobile to tip. If your snowmobile begins to tip while turning, lean more into the turn to regain balance. If necessary, gradually let off on the throttle and/or steer to the outside of the turn.

Remember:

Avoid higher speeds until you are thoroughly familiar with the operation of your snowmobile.

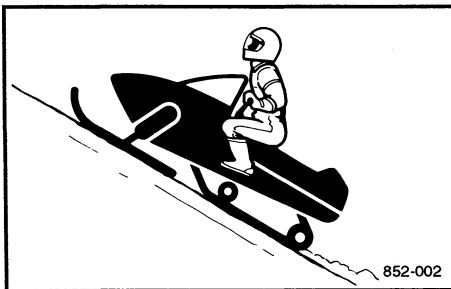

RIDING UPHILL

You should practice first on gentle slopes. Try more difficult climbs only after you have developed your skill. As you approach a hill, accelerate before you start the climb, and then reduce the throttle opening to prevent track slippage. It is also important to keep your weight on the uphill side at all times. On climbs straight up the hill this can be

accomplished by leaning forward and, on steeper inclines, standing on the running boards and leaning forward over the handlebars. (Also see "CROSSING A SLOPE.")

Slow down as you reach the crest of the hill, and be prepared to react to obstacles, sharp drops, or other people or vehicles which may be on the other side.

If you are unable to continue up a hill, do not spin the track. Stop the engine and set the parking brake. Then pull the rear of the snowmobile around to point the machine back down the hill. Do not get on the downhill side of the machine. When the snowmobile is pointed downhill, restart the engine, release the parking brake, and descend the hill.

⚠ WARNING

Side hills and steep slopes are not recommended for a beginner or novice snowmobiler.

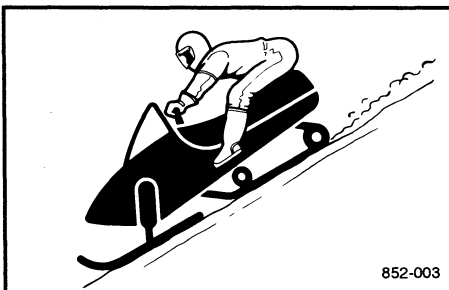

RIDING DOWNHILL

When riding downhill, keep speed to a minimum. It is important to apply just enough throttle to keep the clutch engaged while descending the hill. This will allow you to use engine compression to help slow the machine, and to keep the snowmobile from rolling freely down the hill. Also apply the brake frequently, with light pressure.

⚠ WARNING

Use extra caution when applying the brake during descent. Excessive braking will cause the track to lock and will cause a loss of control.

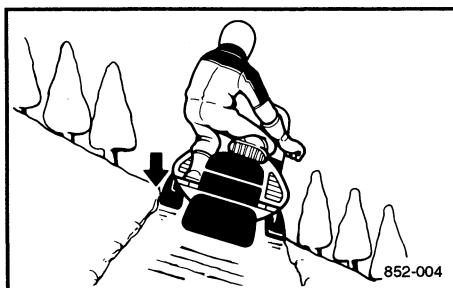

CROSSING A SLOPE (SIDE HILL)

⚠ WARNING

Side hills are not recommended for a beginner or novice snowmobiler.

Crossing the face of a slope (side hill) requires you to properly position your weight to maintain proper balance. As you travel across the slope, lean your body to position your weight towards the uphill side. A recommended riding position is to kneel with the knee of the downhill leg on the seat and the foot of the uphill leg on the running board. This position will make it easier for you to shift your body weight as needed.

Snow and ice are slippery, so be prepared for the possibility that your snowmobile could begin to slip sideways on the slope. If this happens, steer in the direction of the slide if there are no obstacles in your path. As you regain proper balance, gradually steer again in the direction you wish to travel.

If your snowmobile starts to tip, steer down the hill to regain balance.

⚠ WARNING

If you are unable to maintain correct balance, and your snowmobile is going to tip over, dismount your snowmobile immediately on the uphill side.

ICE OR ICY SURFACE

Operating on ice or icy surfaces can be very dangerous. Traction for turning, stopping or starting is much less than that on snow.

⚠ WARNING

When you have to operate on ice or icy surfaces, drive slowly and cautiously. Avoid rapid acceleration, turning or braking. Steering is minimal and uncontrolled spins are an ever-present danger.

HARD-PACKED SNOW

It can be more difficult to negotiate on hard-packed snow as both skis and track do not have as much traction. Avoid rapid acceleration, turning or braking.

OPERATION ON SURFACES OTHER THAN SNOW OR ICE

Operation of your snowmobile on surfaces other than ice or snow should be avoided. Operation under such conditions will damage or result in rapid wear of ski runners, drive track, slide runners and drive sprockets. Operation of the machine under the following conditions should be avoided at all costs:

1. Dirt
2. Sand
3. Rocks
4. Grass
5. Bare pavement

Other conditions that should be avoided for the sake of drive track and slide runner life are:

1. Glare ice surfaces
2. Snow mixed with a lot of dirt and sand

All the above conditions have one thing in common in regard to drive track and slide runners; little or no lubricating ability. Drive track and all slide rail systems require lubrication (snow or water) between the plastic runners and the metal track inserts. In the absence of lubrication, the plastic runners will rapidly wear and in severe cases, literally melt away, and the drive track will be subjected to damage and/or failure.

Also traction aids such as studs, cleats etc., may cause further track damage and/or failure.

⚠ WARNING

Drive track damage and/or failure could result in loss of braking ability and machine control, which could cause an accident.

- Always check the drive track for damage or misadjustment before operating the machine
 - Do not operate the machine if you find damage to the drive track.
-

CAUTION:

Be sure to ride on the fresh snow frequently to avoid rapid wear and damage of the drive track and slide runners when operating under ice or hard packed snow conditions.

ESS42100

DRIVING**⚠ WARNING**

Be sure to read "SAFETY INFORMATION" and "RIDING YOUR SNOWMOBILE" carefully before operating the machine.

NOTE:

Be sure the engine is warmed up enough before riding.

1. Release the parking brake by squeezing the brake lever.
2. Press the throttle lever slowly to move the machine.
3. Turn the handlebar in the desired direction.

4. Squeeze the brake lever to stop the machine.
5. Apply parking brake – squeeze the brake lever and push down the button, then pinch it in place by releasing the brake lever.

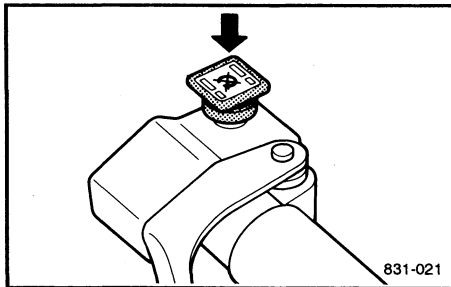
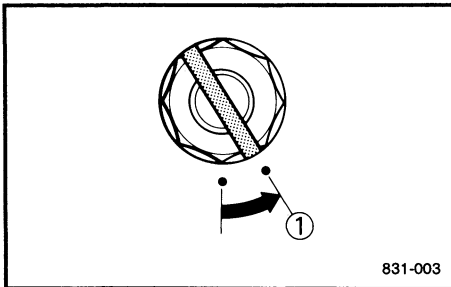

ESS48100

STOPPING THE ENGINE

1. Turn the main switch to the “OFF” position to stop the engine.

① “OFF”

⚠ WARNING

- Push down the engine stop switch to stop the engine in an emergency.
- Be sure the key is removed from the switch whenever the operator leaves the machine, to prevent accidental starting.

ESS45400

TRANSPORTING

When transporting your machine on a trailer or in a truck, observe the following recommendations to help protect your machine from damage:

- Make sure the fuel level in the fuel tank is lower than the carburetors. Otherwise, the vibration and bumps from the road surface could make it possible for fuel to flow through the carburetor into the crankcase. This can result in “hydrostatic lock,” a condition where the engine cannot rotate because of fuel accumulated in the engine. Severe engine damage can result from hydrostatic lock. When possible, the fuel tank should be empty during transportation, especially if the trip will be 30 minutes or longer.
- If transporting the machine in an open trailer or truck, put a tight fitting cover on the machine. A cover specifically designed for your snowmobile is best. This will help keep foreign objects out of the cooling vents in the shroud, and also help protect the machine against damage from debris on the road.
- If transporting the machine in an open trailer or truck in areas where road salt is used, coat metal suspension surfaces lightly with oil or other protectant. This will help protect against corrosion. Be sure to clean the machine when you get to your destination to remove any corrosive salts.

PERIODIC MAINTENANCE

MAINTENANCE CHART

Regular maintenance is most important for best performance and safe operation.

Item	Remarks	Pre-operation check (Daily)	Initial 1 Month or 800 km (500 Mi) (40 hr)	Every	Page
				Seasonally or 3,200 km (2,000 Mi) (160 hr)	
Spark Plug:	Check condition adjust the gap and clean. Replace if necessary.			●	8-4 ~ 8-6
Engine Oil:	Check oil level.	●			6-3
	* Air bleed the oil pump if necessary.			●	
*Oil Filter:	Check condition. Replace if necessary.			●	
Fuel:	Check fuel level.	●			6-1 ~ 6-2
*Fuel Filter:	Check condition. Replace if necessary.			●	
*Fuel Line:	Check fuel hose and fuel cock for cracks or damage. Replace if necessary.			●	
*Oil Line:	Check oil hose for cracks or damage. Replace if necessary.			●	
Carburetor	Check throttle lever operation.	●			5-2, 6-3
	* Adjust the jets.	Whenever operating condition (elevation/temperature) is changed.			
Manual Starter:	Check operation and rope damage. * Replace if necessary.	●			6-3
Engine Stop Switch:	Check operation * Repair if necessary.	●			5-3

* : It is recommended that these items be serviced by a Yamaha dealer or other qualified mechanic.

Item	Remarks	Pre-operation check (Daily)	Initial 1 Month or 800 km (500 Mi) (40 hr)	Every	Page
				Seasonally or 3,200 km (2,000 Mi) (160 hr)	
Throttle Override System:	Check operation. * Repair if necessary.	●			5-2 ~ 5-3, 6-4
Throttle Lever:	Check operation. * Repair if necessary.	●			5-2 ~ 5-3, 6-3
*Exhaust System:	Check for leakage. Retighten or replace gasket if necessary.			●	
*Decarbonization:	More frequently if necessary.			●	
Drive V-belt Guard:	Check cracks, bends or damage. * Replace if necessary.	●			5-5, 6-6
Drive V-belt:	Check wear and damage. Replace if necessary.	●			6-5, 8-12
Drive Track/Idler Wheels:	Check deflection, wear and damage. * Adjust/replace if necessary.	●			6-6, 8-16 ~ 8-19
Slide Runner	Check wear and damage.	●			6-6 ~ 6-7
	* Replace if necessary.			●	
Brake/ Parking Brake	Check operation.	●			5-4, 6-5 8-14 ~ 8-15
	* Adjust free play and/or replace pads if necessary.			●	
Drive Chain Oil	Check oil level.		●		8-13
	* Replace.			●	
Drive Chain:	Check deflection. * Adjust if necessary.		●	●	8-13
Ski/ Ski Runner	Check wear and damage.	●			6-7, 8-20
	* Replace if necessary.			●	
Steering System	Check operation.	●			6-7
	* Adjust toe-out if necessary.			●	
Lights:	Check operation. Replace bulbs if necessary.	●			6-7

* : It is recommended that these items be serviced by a Yamaha dealer or other qualified mechanic.

Item	Remarks	Pre-operation check (Daily)	Initial 1 Month or 800 km (500 Mi) (40 hr)	Every	Page
				Seasonally or 3,200 km (2,000 Mi) (160 hr)	
*Primary Sheave	Check engagement and shift speed.			●	
	Adjust if necessary.	Whenever operating elevation is changed.			
	Check wear and damage. Replace if necessary.			●	
	Lubricate with specified grease.			●	
*Secondary Sheave	Lubricate with specified grease.			●	
	Adjust if necessary.	Whenever operating elevation is changed.			
*Steering Column Bearing:	Lubricate with specified grease.			●	
*Ski and Front Suspension:	Lubricate with specified grease.			●	
*Suspension Component:	Lubricate with specified grease.			●	
*Brake Cable End and Lever End/ Throttle Cable End	Lubricate with specified grease.			●	8-21
	Check cable damage. Replace if necessary.			●	
Shroud Latches:	Make sure the shroud latches are hooked.	●			5-5
Fittings/Fasteners:	Check tightness. * Repair if necessary.	●			6-8
Service Tools/Spare Parts:	Check proper placement.	●			6-8

* : It is recommended that these items be serviced by a Yamaha dealer or other qualified mechanic.

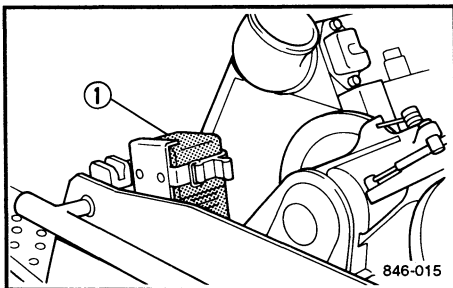

ESS51000

TOOL KIT

The owner's tool kit has the tools which are sufficient for most periodic maintenance and minor repair. A torque wrench is also necessary to properly tighten nuts and bolts.

① Tool kit

NOTE: _____

If you do not have a torque wrench available during a service operation requiring one, take your machine to a Yamaha dealer or other qualified mechanic to check the torque settings and adjust them if necessary.

ESS52000

SPARK PLUG INSPECTION

The spark plug is an important engine component and is easy to inspect. The condition of the spark plug can indicate something of the condition of the engine. Check the coloration on the white porcelain insulator around the center electrode. The ideal coloration at this point is a medium to a light tan color for a machine that is being ridden normally. If a spark plug shows a distinctly different color, there could be something wrong with the engine. For example, a very white center electrode porcelain color could indicate an intake track air leak or carburetion problem for that cylinder. Do not attempt to diagnose such problems yourself. Instead, take the machine to your Yamaha dealer.

You should periodically remove and inspect the spark plug because heat and deposits will cause any spark plug to slowly break down and erode. Consult your dealer before changing to a different type of spark plug.

Standard spark plug: BR8HS (NGK)

Spark plugs are produced in several different thread lengths. The thread length (reach) is the distance from the spark plug gasket seat to the end of the threaded portion. If the reach is too long, overheating and engine damage may result. If the reach is too short, spark plug fouling and poor performance may result. Also, if too short, carbon will form on the exposed threads resulting in combustion chamber hot spots and thread damage. Always use a spark plug with the proper reach.

Spark plug reach ①:
12.7 mm (0.50 in)

Before installing any spark plug, measure the electrode gap with a wire thickness gauge and adjust to specification.

Spark plug gap ②:
0.6 ~ 0.7 mm (0.024 ~ 0.028 in)

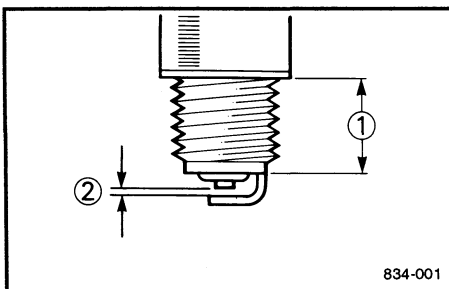

When installing the plug, always clean the gasket surface. Wipe off any grime from the threads and torque the spark plug properly.

Spark plug torque:
28 Nm (2.8 m·kg, 20 ft·lb)

ESS52700

ENGINE IDLE SPEED ADJUSTMENT

CAUTION:

- Be sure this adjustment is serviced by a Yamaha dealer or other qualified mechanic.
- Be sure the throttle lever moves smoothly.

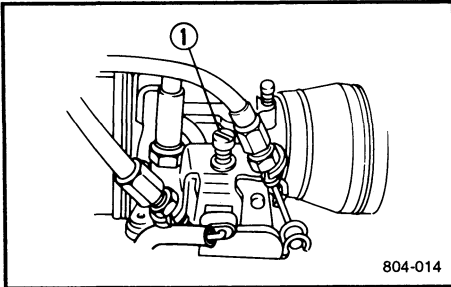

1. Start the engine.

NOTE:

Refer to STARTING THE ENGINE.

2. Turn the throttle stop screw ① in or out to adjust the engine idle speed.

Standard Engine Idle Speed:
1100 ± 100 r/min

ESS54500

THROTTLE CABLE ADJUSTMENT

CAUTION:

Be sure the engine idle speed is adjusted first.

1. Loosen the adjuster locknut.
2. Turn the adjuster in or out until proper throttle lever free play is achieved.

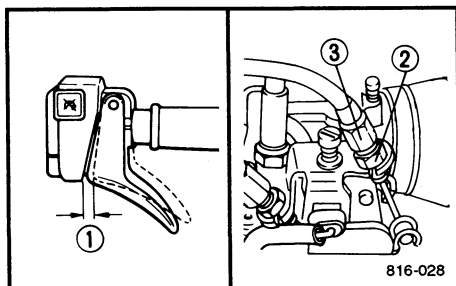

Throttle Lever Free Play ①:
1.0 ~ 2.0 mm (0.04 ~ 0.08 in)

- ② Locknut
- ③ Adjuster

3. Tighten the locknut.

ESS54600

OIL PUMP CABLE ADJUSTMENT

CAUTION:

Be sure the throttle cable is adjusted first.

1. Loosen the adjuster locknut.
2. Pull the oil pump outer cable and adjust the free play between the adjuster and outer cable by turning the adjuster in or out.

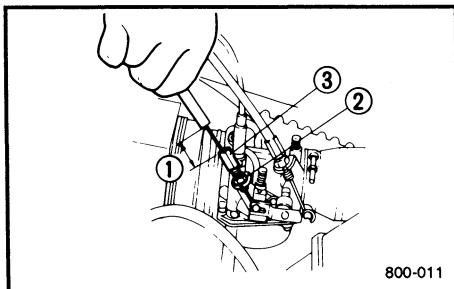

Pump Cable Free Play ①:
 25 ± 1 mm (0.98 ± 0.04 in)

- ② Locknut
- ③ Adjuster

3. Tighten the locknut.

CARBURETOR ADJUSTMENT

CAUTION:

- Be sure this adjustment is serviced by a Yamaha dealer or other qualified mechanic.
- Be sure the carburetor silencer is installed during running to prevent engine damage.

Under some operating conditions the carburetor setting may have to be changed due to air temperature changes, elevation changes, use of alcohol oxygenated fuels, etc. and should be done by an authorized Yamaha Dealer.

CAUTION:

The drive chain gears and V-belt clutch should be adjusted when operating over 900 m (3000 ft) high altitude. Consult a Yamaha dealer.

Pilot Screw Adjustment

Turn the pilot screw in or out to adjust low speed tuning.

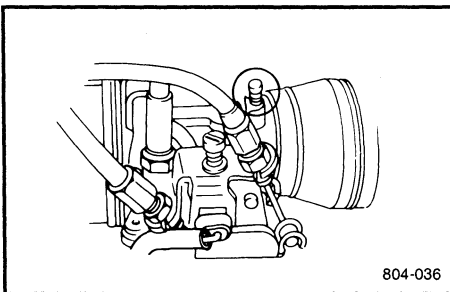

Standard Pilot Screw Position:

1 and 1/4
turns out from the seated
position

Pilot Screw	Mixture	Condition
Turn in	Leaner	Warmer Weather
		Higher Altitude
Turn out	Richer	Colder Weather
		Lower Altitude

Main Jet Replacement

Replace the main jet according to the setting chart which is available at an authorized Yamaha dealer.

⚠ WARNING

- **Never remove the drain plug or the float chamber while the engine is hot.**
Fuel will flow out from the float chamber which could ignite and cause injury.
- **Place a rag under the carburetor before removing the drain plug or float chamber to catch any spilled fuel.**
- **Handle fuel with care: it is highly flammable.**

Standard Main Jet:
#105

Main Jet	Mixture	Condition
Smaller No.	Leaner	Warmer Weather
		Higher Altitude
Larger No.	Richer	Colder Weather
		Lower Altitude

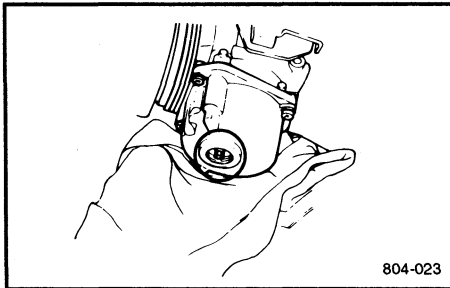

1. Loosen the carburetor clamps and turn over the carburetor.
2. Pinch the fuel hose to prevent fuel flowing.
3. Remove the drain plug and install the proper main jet.
4. Assemble by reversing the removal steps.

⚠ WARNING

Be sure the throttle outer cable is firmly seated in the holder and the throttle operates smoothly after assembling the carburetor.

HIGH ALTITUDE ADJUSTMENTS

Operating at high altitude reduces the performance of a gasoline engine, about 3% for every 305 m (1000 ft.) of elevation. This is because there is less air as altitude increases. Less air means less oxygen available for combustion.

Your snowmobile can be adjusted to overcome most of the problems found in high altitude riding. Carburetor adjustments are the most important. Less air at high altitude makes the fuel/air ratio too rich, which can cause poor performance. Common problems are hard starting, bogging, and plug fouling. Follow the Main Jet Setting chart which is available at an authorized Yamaha dealer carefully. Proper carburetion adjustments will correct the fuel/air ratio.

Remember: less air at higher altitude means there is less horsepower available, even with proper carburetion. Expect acceleration and top speed to be reduced at higher altitudes.

To overcome operating with less power at high altitudes, your snowmobile may also require different clutch and driveline settings to avoid poor performance and rapid wear. If you plan to operate your snowmobile at an altitude different from the area where you bought your machine, be sure to consult your Yamaha dealer. He can tell you if there are any changes necessary for the altitude where you plan to ride.

ESS61500

DRIVE V-BELT REPLACEMENT

NOTE: _____
Apply the parking brake before replacement.

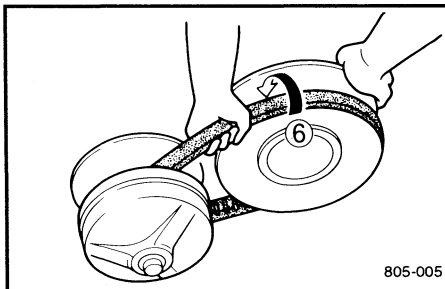
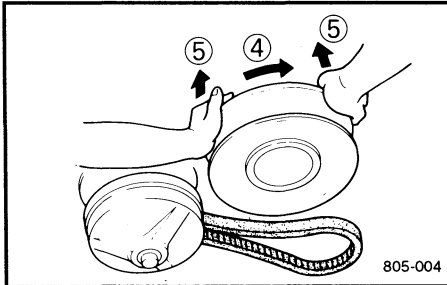
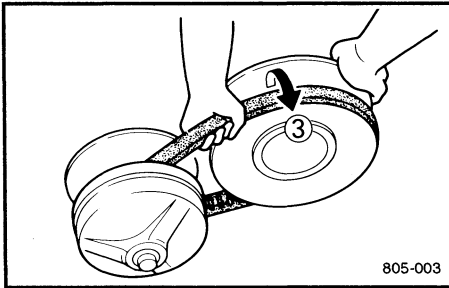
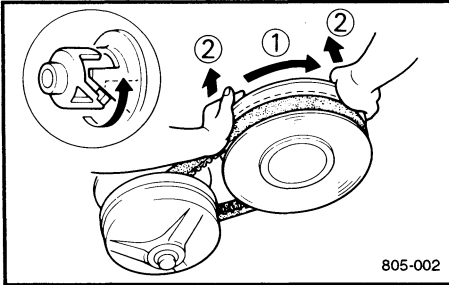

1. Remove the drive V-belt guard.
2. Rotate the secondary sliding sheave clockwise ① and push ② so that it separates from the fixed sheave.
3. Pull ③ the belt up over the secondary fixed sheave.
4. Remove the belt from the secondary sheave and primary sheave.
5. Install the new belt over the primary sheave.

6. Rotate the secondary sliding sheave clockwise ④ and push ⑤ so that it separates from the fixed sheave.

7. Install the belt ⑥ between secondary sliding and fixed sheave.
8. Install the drive V-belt guard.

⚠ WARNING _____
Never run the engine without the drive V-belt or with the drive V-belt guard removed.

ESS68800

DRIVE CHAIN HOUSING

Oil Replenishing

1. Check the oil level by removing the level bolt and filler cap.

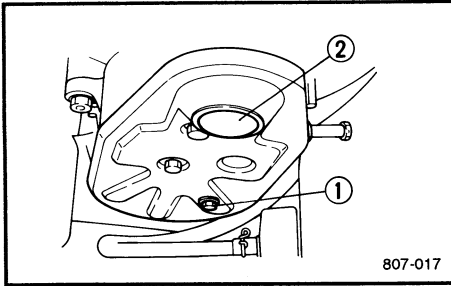

Oil flowing from level bolt hole	Oil level
Slight flow	CORRECT
No flow	insufficient

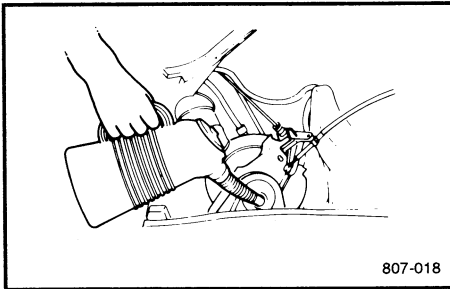

- ① Level bolt
- ② Filler cap

2. Add chain oil until it begins to flow out from the level hole.

Drive Chain Oil:
API GL-3
SAE 75 or 80

CAUTION:

Be sure no foreign material enters the gearcase.

3. Check the level hole bolt gasket. If damaged, replace it.
4. Install the level hole bolt and filler cap.

Chain Adjustment

1. Loosen the adjuster locknut.
2. Turn the adjuster in finger-tight.

- ① Locknut
- ② Adjuster

3. Tighten the locknut.

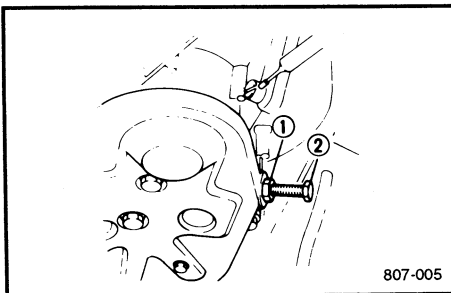

BRAKE/PARKING BRAKE

Checking Pad Wear

Check pad wear by measuring the thickness of the brake pad.

If the pad reaches the wear limit, consult a Yamaha dealer for replacement.

Wear limit ①:

1.0 mm (0.04 in)

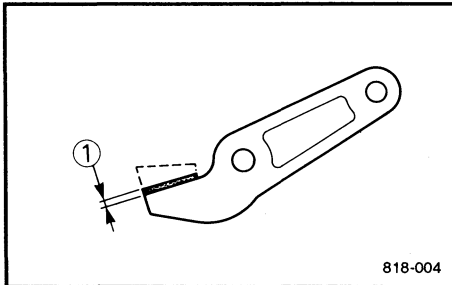

Adjustment

Brake adjustment is necessary when the brake lever exceeds the proper free play.

⚠ WARNING

Be sure this adjustment is serviced by a Yamaha dealer or other qualified mechanic.

1. Loosen the locknut ①.
2. Turn the pad adjuster ② in or out to adjust the clearance between the pad ③ and disc ④.

Clearance ⑤:

0.2 ~ 1.0 mm (0.008 ~ 0.04 in)

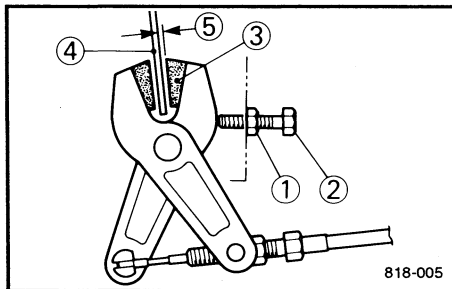

3. Turn the cable adjuster ⑥ in or out to adjust the clearance between the pad ⑦ and disc ④.

Clearance ⑧:

0.2 ~ 1.0 mm (0.008 ~ 0.04 in)

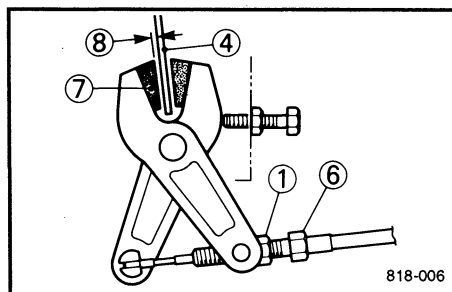

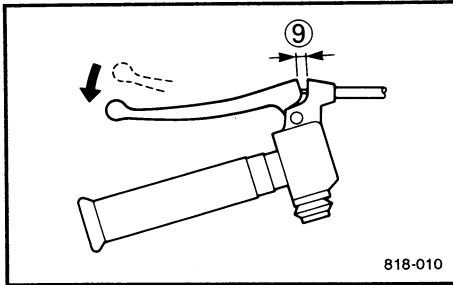

4. Check the brake lever free play.

Brake Lever Free Play ⑨:
6 ~ 7 mm (0.24 ~ 0.28 in)

Repeat steps 2, 3, and 4 until the specified clearances and free play are achieved.

5. Tighten the locknut.

ESS69001

SUSPENSION

The suspension can be adjusted to suit rider preference. A softer setting, for example, may provide greater rider comfort, while a stiffer setting may allow more precise handling and control over certain types of terrain or riding conditions.

⚠ WARNING

Be sure this adjustment is serviced by a Yamaha dealer or other qualified mechanic.

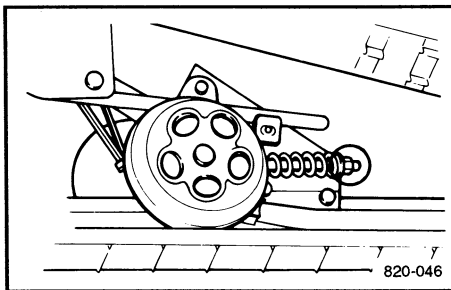

⚠ WARNING

This shock absorber contains highly pressurized nitrogen gas. It could explode by improper handling, causing injury or property damage.

- Do not tamper with or attempt to open the shock absorber assembly.
- Do not subject the shock absorber assembly to open flame or other high heat, which could cause it to explode.
- Do not deform or damage the shock absorber in any way.
- Do not dispose of a damaged or worn out shock absorber by yourself. Take the unit to your Yamaha dealer or other qualified mechanic.

ESS68701

TRACK ADJUSTMENT

⚠ WARNING

A broken track, track fittings, or debris thrown by the track could be dangerous to an operator or bystanders. Observe the following precautions:

- Do not allow anyone to stand behind the machine when the engine is running.

- When the rear of the machine is raised to allow the track to spin, a suitable stand must be used to support the rear of the machine. Never allow anyone to hold the rear of the machine off the ground to allow the track to spin. Never allow anyone near a rotating track.
- Inspect track condition frequently. Replace damaged track guide clips. Replace the track if it is damaged to the depth where fabric reinforcement material is visible or support rods are broken. Otherwise, track damage and/or failure could result in loss of braking ability and machine control, which could cause an accident.
- Never install studs (cleats) closer than three inches from the edge of the track.

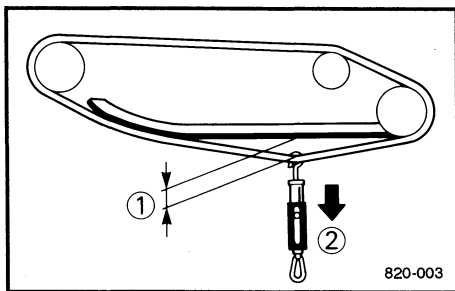

Track Deflection Measurement

1. Lay the machine on its side.
2. Measure the track deflection with a spring scale. Pull at the center of the track with a force of 100 N {10 kgf (22 lbs.)}.

NOTE: _____
 Measure the gap between the slide runner and the edge of the track window. Measure both sides.

- ① Deflection
- ② 100 N {10 kgf (22 lbs.)}

Standard Track Deflection:
 40 ~ 50 mm (1.57 ~ 1.97 in)/
 100 N {10 kgf (22 lbs.)}

3. If the deflection is incorrect, adjust the track.

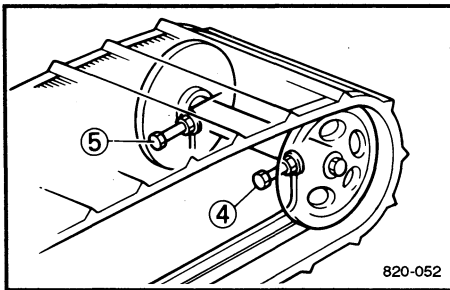
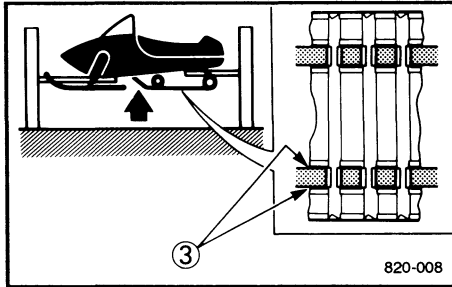
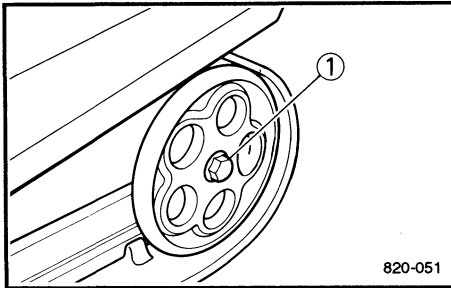

Track Adjustment

⚠ WARNING

- Be sure this adjustment is made by a Yamaha dealer or other qualified mechanic.
- Support the machine securely on a suitable stand before working underneath the machine.
- Operate the engine in a well-ventilated area.

1. Lift the rear of the machine onto a suitable stand to raise the track off the ground.
2. Loosen the rear axle bolts (1).
3. Start the engine and rotate the track one or two turns. Stop the engine.
4. Check the track alignment with the slide runner (3).

If the alignment is incorrect, turn the left and right adjuster to adjust.

Track alignment	⑥ Shifted to right	⑦ Shifted to left
④ Left adjuster	Turn out	Turn in
⑤ Right adjuster	Turn in	Turn out

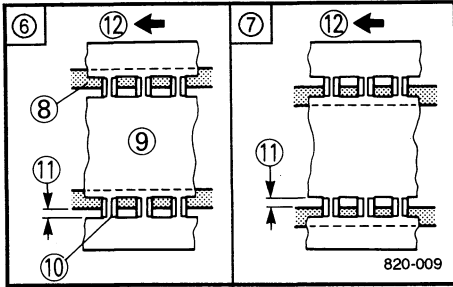

- ⑧ Slide runner
- ⑨ Track
- ⑩ Track metal
- ⑪ Gap
- ⑫ Forward

NOTE: _____

Install the box ⑬ and wrench ⑭ of the tool kit on the adjuster locknut ⑮ to turn the adjuster as follows;

- Set the wrench as far as space permits and turn it.
- Remove the wrench and turn it over ⑯ and install wrench on the box.
- Repeat the above steps.

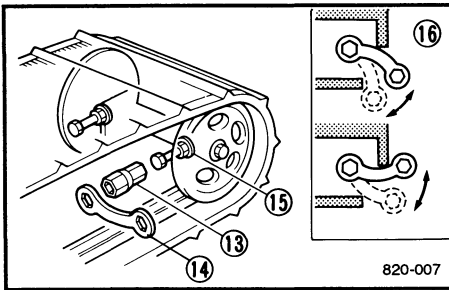

5. Adjust track deflection to the specified amount.

Track deflection	More than Specified	Less than Specified
④ Left adjuster	Turn in	Turn out
⑤ Right adjuster	Turn in	Turn out

CAUTION: _____

The adjusters should be turned an equal amount.

6. Recheck alignment and deflection. If necessary, repeat steps 3 to 5 until proper adjustment is achieved.
7. Tighten the rear axle bolts.

ESS62900

SKI ALIGNMENT

1. Turn the handlebars so the skis face straight ahead.
2. Check the following for ski alignment
 - 1) Ski is facing forward.
 - 2) Ski toe-out (① - ②) is within specification.

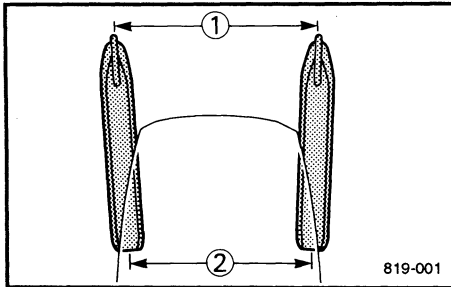

Ski Toe-out (① - ②):
0 ~ 15 mm (0.0 ~ 0.6 in)

3. If alignment is not correct, consult a Yamaha dealer.

ESS63100

HANDLEBAR ADJUSTMENT

1. Loosen the handlebar bolts. Move the handlebar assembly up or down to adjust the handlebar height to the desired position.
2. Tighten the handlebar bolts.

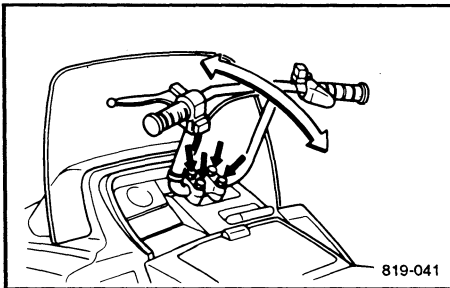

Handlebar Bolt Tightening Torque:
14 Nm (1.4 m·kg, 1.0 ft·lb)

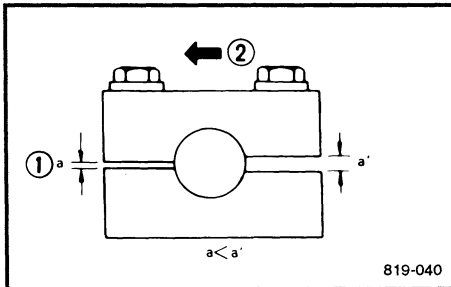

CAUTION:

Be sure the small gap ① side of the holder faces forward ②.

ESS62700

LUBRICATION

Lubricate the following points.

Lubricant:
Low-temperature grease

- ① Ski Wear Plate
- ② Brake/Throttle cable ends

⚠ WARNING

Apply a dab of grease to the cable end only.

Do not grease the brake/throttle cables themselves because they could become frozen, which could cause loss of control.

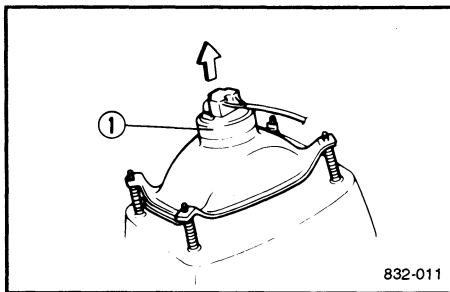
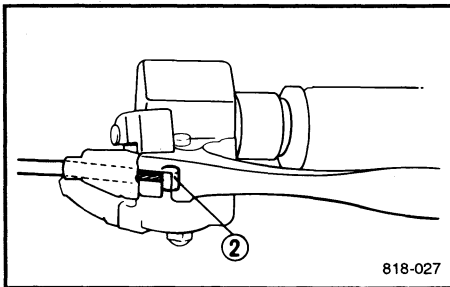
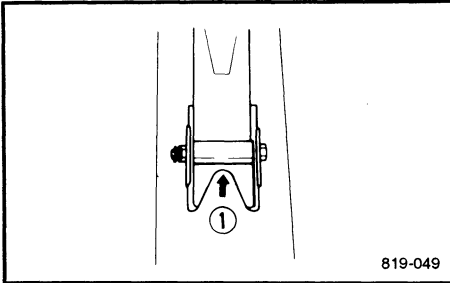

ESS64500

HEADLIGHT

Bulb Replacement

1. Lift up the shroud.
2. Disconnect the lead coupler.
3. Remove the bulb cover.
4. Remove the bulb holder by depressing and turning it counterclockwise.

- ① Bulb cover

5. Remove the bulb.

⚠ WARNING

Keep flammable products or your hands away from the hot bulb until it cools down.

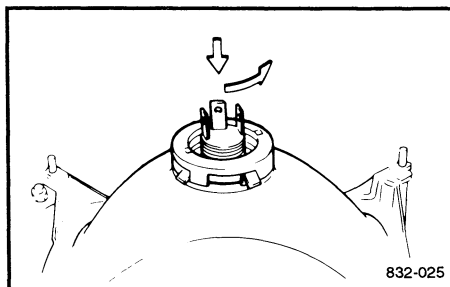

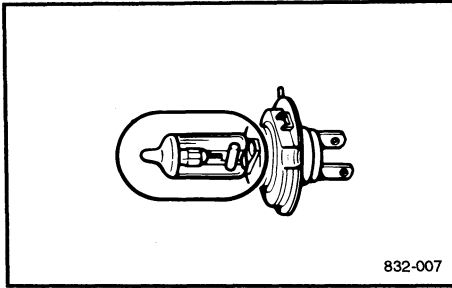

6. Install the new bulb.

Bulb Type:
12 V 60/55 W

CAUTION:

Keep oil or your hands away from the glass part of bulb or its life and illumination will be affected.

If the glass is oil stained, thoroughly clean it with a cloth moistened with alcohol or lacquer thinner.

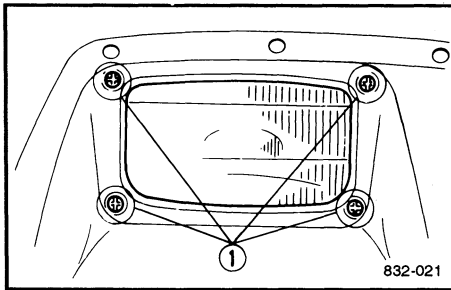

Beam Adjustment

1. Turn the adjuster ① in or out to adjust the headlight beam.

TROUBLESHOOTING

A. Engine turns over but doesn't start

1. Fuel System

No fuel supplied to combustion chamber

- No fuel in tanks ... Supply fuel both tanks.
- Clogged fuel line ... Clean fuel line.
- Foreign matter in fuel cock ... Clean fuel cock.
- Clogged carburetor ... Clean carburetor.
Fuel supplied to combustion chamber.
- Flooded engine (too much choke) ... Crank engine with throttle open or wipe spark plug dry.

2. Electrical System

Poor or no spark

- Spark plug dirty with carbon/wet ... Remove carbon/wipe spark plug dry, or replace spark plug.
- Faulty ignition system ... Consult dealer.
- T.O.R.S. system malfunction ... Disconnect the carburetor switch connectors and connect the wire harness connectors together to bypass T.O.R.S..

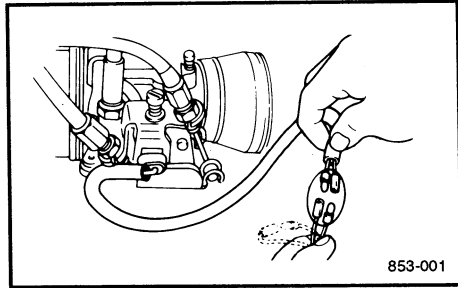

⚠ WARNING

- Before bypassing the T.O.R.S., be sure the throttle returns properly to the fully-closed position.
- The T.O.R.S. is an important safety device; in the case of a malfunction, take the machine to a Yamaha dealer immediately for repair.

3. Compression

Insufficient

- Loose cylinder head nuts ... Tighten nuts properly.
- Damaged gasket ... Replace gasket.
- Worn out piston and cylinder ... Consult dealer.

B. Engine does not turn over with manual starter

1. Seized engine ... Seizure is caused by poor lubrication, inadequate fuel, or an air leak — Consult dealer.
2. "Hydrolock" (fuel has filled crankcase when vehicle was transported) ... Remove spark plug(s), turn engine over several times with ignition off to expel excess fuel. Consult dealer.

C. Engine power is low

1. Faulty spark plug(s) ... Clean or replace spark plug(s).
2. Jetting incorrect for altitude or temperature ... carburetor. Consult dealer.
3. Improper fuel flow ... See A.1. above.
4. Clutch settings not correct for altitude and/or conditions ... Consult dealer.

D. Engine constantly backfires or misfires

1. Faulty spark plug(s) ... Replace spark plug(s).
2. Fuel system clogged ... See A.1. above.
3. T.O.R.S. malfunction ... See T.O.R.S. in A.2. above.

E. Machine does not move

1. Clutch malfunction ... Consult dealer.
2. Drive track does not move ... foreign object is caught in track, or slide runner has melted to track metal due to lack of lubrication.
3. Drive chain too tight, too loose, or broken ... Consult dealer.

F. Drive belt twists

1. Improper belt ... Replace with correct belt.
2. Clutch offset incorrect ... Consult dealer.
3. Engine mount loose or broken ... Consult dealer.

G. Drive belt slips or burns

1. Belt or sheave surface oily or dirty ... clean.
2. Problem with drive line ... See E above.

H. Engine does not upshift or downshift properly/engages harshly

1. Drive belt worn ... replace belt or consult dealer.
2. Clutch settings incorrect for altitude/conditions ... Consult dealer.
3. Primary clutch worn or sticking ... Consult dealer.
4. Secondary clutch worn or sticking ... Consult dealer.

I. Noise or excessive vibration in drive line

1. Broken clutch components ... Consult dealer.
2. Worn or damaged bearings ... Consult dealer.
3. Drive belt damaged or worn with flat spots ... Replace.
4. Idler wheel/shaft damage ... Consult dealer.
5. Track damaged ... Consult dealer.

STORAGE

Long term storage, requires some preventive procedures to guard against deterioration.

1. Cleaning

Thoroughly clean the machine, inside and out, to remove the corrosive salts and acids that can accumulate. Use Yamaha Mud and Grease Release, or an equivalent, to loosen mud, grease and grime. Wash with mild soap, then rinse and dry completely.

2. Lubrication

Lubricate moving parts, suspension linkage and pivot points. Use the grease or lubricant specified in the MAINTENANCE section, or Yamaha Lube-Zall general purpose lubricant. Proper lubrication fights corrosion while it reduces friction.

3. Fuel System Preparation

Add Yamaha Fuel Conditioner/Stabilizer, or an equivalent, to the fuel tank to help prevent fuel oxidation, gum and varnish deposits, and to inhibit corrosion in the fuel system and carburetor. In areas where oxygenated fuel ("gasohol") is used, completely drain the fuel system. Consult your Yamaha dealer or other qualified mechanic.

4. Engine

Proper storage of the engine is essential to prevent costly rust and corrosion damage to internal engine components. This is more important than ever in those areas where oxygenated fuel ("gasohol") is used, because the alcohol content in the fuel increases the chance for water to enter the engine. Use Yamaha Store-Rite Fogging Oil, or an equivalent, to protect both combustion chamber and crankshaft from corrosion. An alternate method is to remove the airbox and squirt oil into the carburetor throats while the engine is running.

CAUTION:

Do not attempt to store the machine by simply starting the engine occasionally during the storage period. This can cause more harm than good! Moisture and acids form during combustion which can actually increase the chance for corrosion damage during the storage period.

5. Protection

Apply a coat of wax, such as Yamaha Silicone Wax, to painted surfaces. Spray Yamaha Silicone Spray, or an equivalent protectant, on the exterior of the engine, on the track, and on other metal, plastic and rubber parts.

6. Battery (if equipped)

Remove the battery from the machine and check fluid level. Charge the battery. Store it in a cool, dry place that is above 0°C (32°F), but less than 30°C (90°F). Check battery condition with a hydrometer monthly, and charge as necessary.

⚠ WARNING

- **Never smoke or make and break connections at the battery while charging. Sparks may ignite the battery gas.**
- **Be sure the battery terminals are tight and that the battery vent tube is properly routed and is securely attached to the battery.**

CAUTION:

Do not charge battery quickly. Charge for 10 hours at 1.4 amperes.

7. Track

Loosen the track, and block up the chassis so that the track is suspended above the ground.

8. Drive Belt

Remove the drive belt and store separately.

9. Storage

Store the machine in a dry, well-ventilated place out of direct sunlight. Put a fabric (breathable) cover over it, preferably one designed for your machine. Do not use a plastic or vinyl cover — condensation could be trapped underneath which could increase the chance of rusting.

RETURN TO SERVICE AFTER STORAGE

When returning your machine to service, reinstall the drive belt and adjust the track.

Reinstall the battery, and make sure the battery vent tube is properly reinstalled and is not kinked.

Remove the spark plugs and clean them or replace them. Perform all other pre-operation and seasonal maintenance listed in the Periodic Maintenance chart.

For peak performance, it is recommended that you have your machine checked and tuned by your Yamaha dealer. He has the experience and training to help you get the maximum performance and use from your Yamaha.

ESG73000

SPECIFICATIONS

ESS73200

DIMENSIONS

	BR250T
Model code Number	
Overall length	2945 mm (115.9 in)
Overall width	950 mm (37.4 in)
Overall height	1120 mm (44.1 in)
Dry Weight	175 kg (385.8 lb)
Ski Tread	750 mm (29.5 in)

ESS75100

ENGINE

	BR250T
Type	Fan cooled two-stroke, 5-port
Cylinder Arrangement	1-cylinder
Displacement	246 cm ³
Bore and Stroke	70 × 64 mm (2.76 × 2.52 in)
Idle Speed	1100 ± 100 r/min
Engine Oil Type	YAMALUBE 2-cycle oil
Carburetor Type	KEIHIN BD32-28 × 1
Fuel	Unleaded gasoline
	Pump Octane $\frac{R + M}{2}$; 88
Starting System	Manual with recoil starter

CHASSIS

	BR250T
Drive track and suspension: Track Width Track deflection Length on ground Suspension type Drive sprocket	Molded rubber, fiber glass rod reinforced 381 mm (15 in) 40 ~ 50 mm (1.57 ~ 1.97 in)/ 100 N {(10 kgf (22 lbs.))} 1126 mm (44.3 in) Slide rail suspension Double polyethylene, 7 teeth
Transmission: Type Sheave distance Sheave offset Engagement speed* Shift Speed* Drive chain Reduction ratio	Automatic centrifugal engagement, infinitely variable 3.5:1 ~ 1:1 Approx. 266 mm (10.47 in) Approx. 11 mm (0.43 in) Approx. 3200 r/min Approx. 5900 r/min Single roller chain enclosed in oil bath 24/10 (2.4)
Fuel tank: Tank capacity	Main tank: 15 L (3.3 Imp gal, 4.0 US gal) Sub tank: 9.3 L (2.05 Imp gal, 2.46 US gal)
Oil tank: Tank capacity	1.8 L (1.6 Imp qt, 1.9 US qt)
Brake: Type Operation	Caliper type, disc brake Handle lever, left hand operated
Throttle: Operation	Handle lever, right hand operated

*Subject to change according to elevation settings.

ELECTRIC

		BR250T
Ignition System		C.D.I.
Spark Plug	Type	BR8HS (NGK)
	Gap	0.6 ~ 0.7 mm (0.024 ~ 0.028 in)
Headlight	Bulb × Quantity	12 V, 60/55 W × 1
Tail/brake light	Bulb × Quantity	12 V, 8/23 W × 1
Meter light	Bulb × Quantity	12 V, 3.4 W × 1

WIRING DIAGRAM

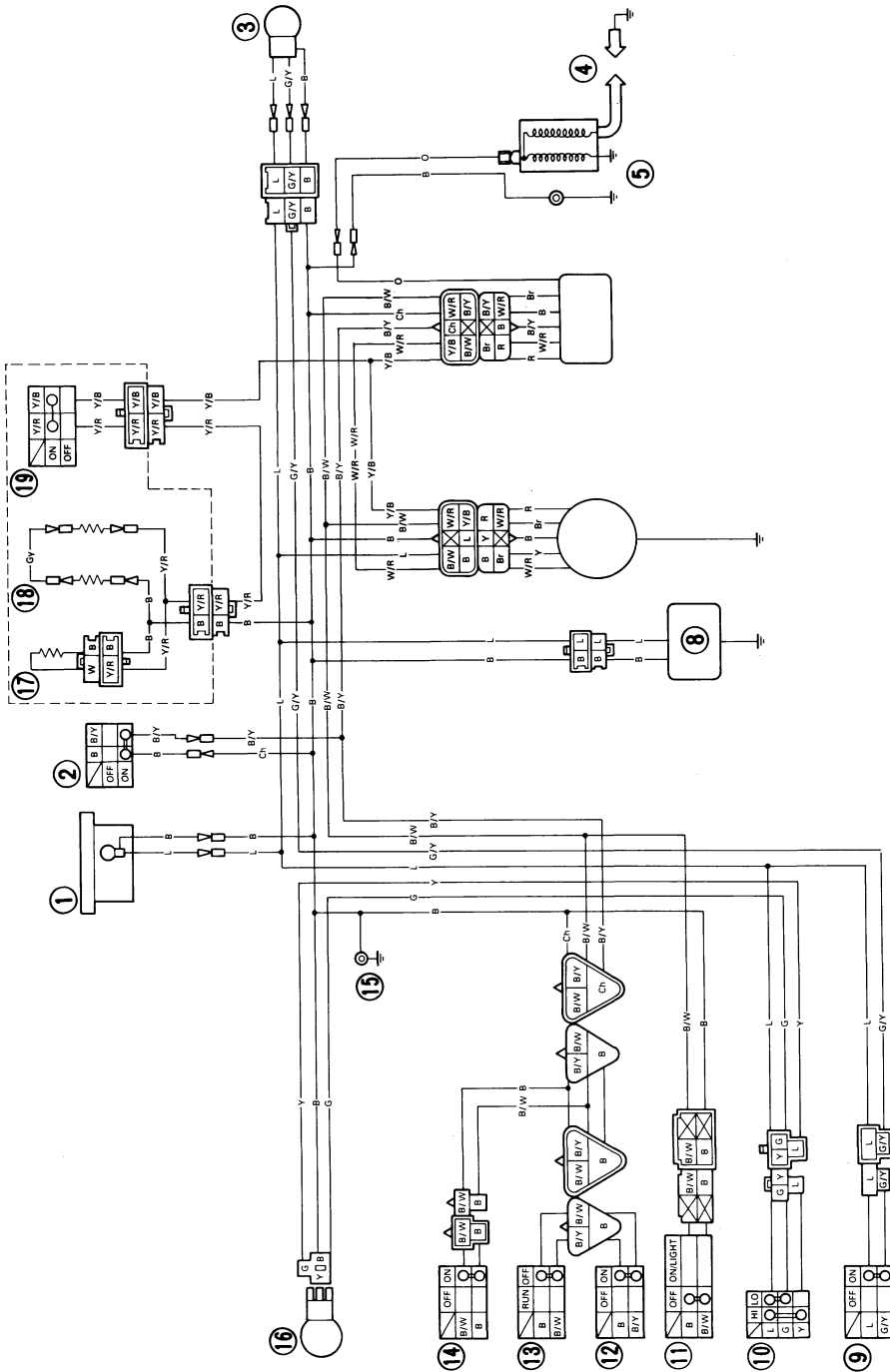

COLOR CODE

B	Black
L	Blue
G	Green
Y	Yellow
R	Red
O	Orange
Br	Brown
B/Y	Black/Yellow
B/W	Black/White
G/Y	Green/Yellow
Y/B	Yellow/Black
Y/R	Yellow/Red
W/R	White/Red

- ① Speedometer light
- ② Carb switch
- ③ Tail/Stop light
- ④ Spark plug
- ⑤ Ignition coil
- ⑥ CDI unit
- ⑦ CDI magneto
- ⑧ Voltage regulator
- ⑨ Stop light switch
- ⑩ Headlight beam switch
- ⑪ Main switch
- ⑫ Accel switch
- ⑬ Engine stop switch
- ⑭ Engine stop switch
- ⑮ Body earth
- ⑯ Headlight
- ⑰ Thumb warmer (Option)
- ⑱ Grip warmer (Option)
- ⑲ Grip warmer switch (Option)

-MEMO-

Free Manuals Download Website

<http://myh66.com>

<http://usermanuals.us>

<http://www.somanuals.com>

<http://www.4manuals.cc>

<http://www.manual-lib.com>

<http://www.404manual.com>

<http://www.luxmanual.com>

<http://aubethermostatmanual.com>

Golf course search by state

<http://golfingnear.com>

Email search by domain

<http://emailbydomain.com>

Auto manuals search

<http://auto.somanuals.com>

TV manuals search

<http://tv.somanuals.com>