

# YAMAHA

Marine

# Outboard

**SX150Y  
LX150Y  
SX200Y  
LX200Y**  
OWNER'S MANUAL

U.S.A. Edition

LIT-18626-03-68 ●



EMU00000

## TO THE OWNER

Thank you for choosing a Yamaha outboard motor. This Owner's manual contains information needed for proper operation, maintenance and care. A thorough understanding of these simple instructions will help you obtain maximum enjoyment from your new Yamaha. If you have any question about the operation or maintenance of your outboard motor, please consult a Yamaha dealer.

In this Owner's Manual particularly important information is distinguished in the following ways.



The Safety Alert Symbol means  
**ATTENTION! BECOME ALERT!  
YOUR SAFETY IS INVOLVED!**

### **WARNING**

**Failure to follow WARNING instructions could result in severe injury or death to the machine operator, a bystander, or a person inspecting or repairing the outboard motor.**

### **CAUTION:**

**A CAUTION indicates special precautions that must be taken to avoid damage to the outboard motor.**

### **NOTE:**

A NOTE provides key information to make procedures easier or clearer.

\* Yamaha continually seeks advancements in product design and quality. Therefore, while this manual contains the most current product information available at the time of printing, there may be minor discrepancies between your machine and this manual. If there is any question concerning this manual, please consult your Yamaha dealer.







**Yamaha Motor Co., Ltd.**

EMA10010

**SX150Y/LX150Y/SX200Y/LX200Y  
OWNER'S MANUAL  
©1999 by Yamaha Motor Co., Ltd.  
1st Edition, March 1999  
All rights reserved. Any reprinting or  
unauthorized use without the written  
permission of Yamaha Motor Corporation,  
U.S.A. is expressly prohibited.  
Printed in Japan  
P/N LIT-18626-03-68**

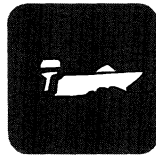

# CONTENTS

	<b>GENERAL INFORMATION</b>	<b>1</b>
	<b>BASIC COMPONENTS</b>	<b>2</b>
	<b>OPERATION</b>	<b>3</b>
	<b>MAINTENANCE</b>	<b>4</b>
	<b>TROUBLE RECOVERY</b>	<b>5</b>
	<b>INDEX</b>	<b>6</b>

**READ THIS OWNER'S MANUAL CAREFULLY  
BEFORE OPERATING YOUR OUTBOARD MOTOR.**



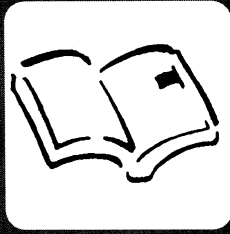

EMU00004

## Chapter 1

1

# GENERAL INFORMATION

<b>IDENTIFICATION NUMBERS RECORD ..</b>	1-1
Outboard motor serial number.....	1-1
Key number.....	1-1
<b>EMISSION CONTROL INFORMATION...</b>	1-2
<b>SAFETY INFORMATION.....</b>	1-3
<b>IMPORTANT LABELS .....</b>	1-5
<b>BASIC BOATING RULES .....</b>	1-6
<b>FUELING INSTRUCTIONS.....</b>	1-10
Gasoline (petrol).....	1-11
Engine oil .....	1-11
<b>BATTERY REQUIREMENT .....</b>	1-12
<b>PROPELLER SELECTION .....</b>	1-12
<b>START-IN-GEAR PROTECTION .....</b>	1-13



EMU00005

## IDENTIFICATION NUMBERS RECORD

EMU00007

### OUTBOARD MOTOR SERIAL NUMBER

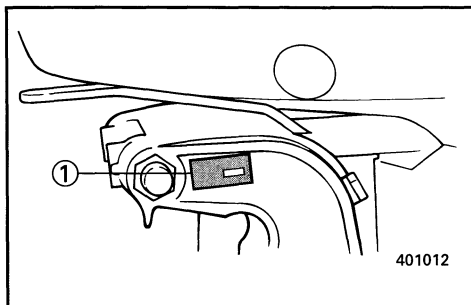

The outboard motor serial number is stamped on the label attached to the port side of the clamp-bracket.

Record your outboard motor serial number in the spaces provided to assist you in ordering spare parts from your Yamaha dealer or for reference in case your outboard motor is stolen.

- ① Outboard motor serial number

EMU00008

### KEY NUMBER

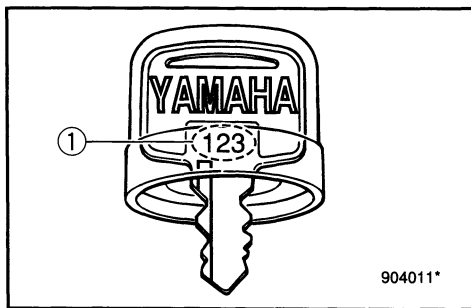
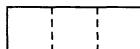

If main key switch is equipped, your key identification number is stamped on your key as shown in the illustration. Record this number in the space provided for reference if you need a new key.

- ① Key number





E

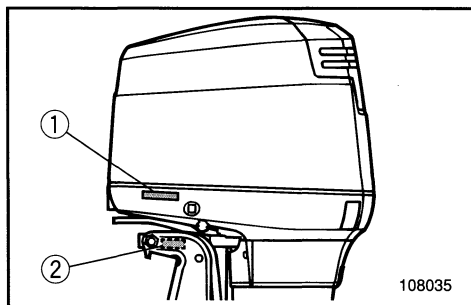

EMU01079\*

## EMISSION CONTROL INFORMATION

This engine conforms to 2000 U.S. Environmental Protection Agency (EPA) regulation for marine SI engines.

### Approval label of Emission control certificate

This label is attached to the bottom cowling.

- ① Emission control information label

EMISSION CONTROL INFORMATION	
ENGINE FAMILY : .....	
THIS ENGINE CONFORMS TO 2000 U.S. EPA REGULATIONS FOR MARINE SI ENGINES.	
FELs : ..... g/kw-hr	IDLE SPEED : ..... rpm IN NEUTRAL
SPARK PLUG : .....	SPARK PLUG GAP (mm) : .....
YAMAHA MOTOR CO.,LTD. ....	

### Existing Technology ; N/A

### Manufactured date label

This label is attached to the clamp bracket or the swivel bracket.

- ② Manufactured date label

<b>YAMAHA</b>
Manufactured: <input type="text"/> <input type="text"/> <input type="text"/> <input type="text"/> <input type="text"/> <input type="text"/>



EMU00917



## **SAFETY INFORMATION**

- Before mounting or operating the outboard motor, read this entire manual. Reading it should give you an understanding of the motor and its operation.
- Before operating the boat, read any owner's or operator's manuals supplied with it and all labels. Be sure you understand each item before operating.
- Do not overpower the boat with this outboard motor. Overpowering the boat could result in loss of control. The rated power of the outboard should be equal to or less than the rated horsepower capacity of the boat. If the rated horsepower capacity of the boat is unknown, consult the dealer or boat manufacturer.
- Do not modify the outboard. Modifications could make the motor unfit or unsafe to use.
- Never operate after drinking alcohol or taking drugs. About 50% of all boating fatalities involve intoxication.
- Have an approved personal flotation device (PFD) on board for every occupant. It is a good idea to wear a PFD whenever boating. At a minimum, children and non-swimmers should always wear PFDs, and everyone should wear PFDs when there are potentially hazardous boating conditions.
- Gasoline is highly flammable, and its vapors are flammable and explosive. Handle and store gasoline carefully. Make sure there are no gas fumes or leaking fuel before starting the engine.
- This product emits exhaust gases which contain carbon monoxide, a colorless, odorless gas which may cause brain damage or death when inhaled. Symptoms include nausea, dizziness, and drowsiness. Keep cockpit and cabin areas well ventilated. Avoid blocking exhaust outlets.
- Check throttle, shift, and steering for proper operation before starting the engine.
- Attach the engine stop switch lanyard to a secure place on your clothing, or your arm or leg while operating. If you accidentally leave the helm, the lanyard will pull from the switch, stopping the engine.
- Know the marine laws and regulations where you will be boating - and obey them. Refer to "RULES OF THE ROAD" section for basic boating rules.
- Stay informed about the weather. Check weather forecasts before boating. Avoid boating in hazardous weather.
- Tell someone where you are going: leave a Float Plan with a responsible person. Be sure to cancel the Float Plan when you return.
- Use common sense and good judgment when boating. Know your abilities, and be sure you understand how your boat handles under the different boating conditions you may encounter. Operate within your limits, and the limits of your boat. Always operate at safe speeds, and keep a careful watch for obstacles and other traffic.
- Always watch carefully for swimmers during the engine operation.
- Stay away from swimming areas.



- When a swimmer is in the water near you shift into neutral and shut off the engine.
- Be informed about boating safety. Additional publications and information can be obtained from many organizations, including the following:

**United States Coast Guard**

Consumer Affairs Staff (G-BC)  
Office of Boating, Public, and Consumer Affairs  
U.S. Coast Guard Headquarters  
Washington, D.C. 20593-0001  
Boating Safety Hotline: 1-800-368-5647

**National Marine Manufacturers**

**Association (NMMA)**

401 N. Michigan Ave.  
Chicago, IL 60611

**Marine Retailers Association of America**

155 N. Michigan Ave.  
Chicago, IL 60601



EMU00014

### IMPORTANT LABELS WARNING LABELS

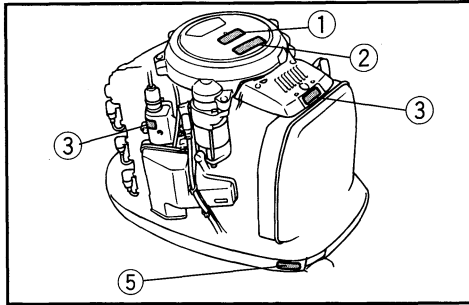

①

**⚠ WARNING**

- Be sure shift control is in neutral before starting engine. (except 2HP)
- Do not touch or remove electrical parts when starting or during operation.
- Keep hands, hair, and clothes away from flywheel and other rotating parts while engine is running.

YAMAHA 6A1-83625-41

②

**⚠ WARNING**

Use only a counterclockwise rotation propeller with this engine. Counterclockwise propellers are marked with a letter "L" after the size indication. The wrong type of propeller could cause the boat to go in an unexpected direction, which could lead to an accident.

YAMAHA 6K1-83623-41

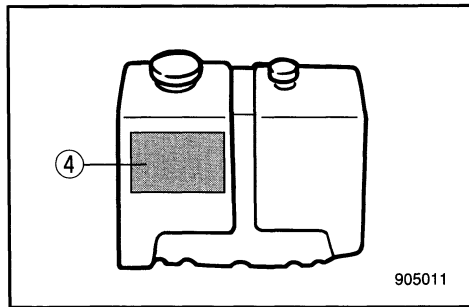

③

**⚠ WARNING**

Hot surface under this cover during and after operation. To avoid burns, do not touch finned resistor with bare hands.

YAMAHA 65L-83625-40

④

**YAMAHA OIL TANK**  
CAPACITY: 10.5 LITERS  
11.1 U.S. qt.  
9.2 IMP. qt.

---

**ENGINE OIL ONLY**

Pour the engine oil into this oil tank, not gasoline.

**RECOMMENDED OIL:**  
YAMALUBE 2 STROKE OUTBOARD OIL or an equivalent TC-W3 certified outboard oil.

**⚠ WARNING**

Do not add gasoline to the oil tank. Fire or explosion could result.

YAMAHA 65L-1007-02

### CAUTION LABELS

⑤

**CAUTION**

UNLEADED GASOLINE ONLY. Gasoline containing lead can cause performance loss and engine damage. Refer to Owner's Manual.

YAMAHA 65L-2415E-40



## BASIC BOATING RULES (Rules of the road)

Just as there are rules which apply when you are driving on streets and high ways, there are waterway rules which apply when you are driving your boat. These rules are used internationally, and are also enforced by the United States Coast Guard and local agencies. You should be aware of these rules, and follow them whenever you encounter another vessel on the water.

Several sets of rules prevail according to geographic location, but are all basically the same as the International Rules of the Road. The rules presented here in your Owner's Manual are condensed, and have been provided for your convenience only. Consult your local U.S. Coast Guard Auxiliary or Department of Motor Vehicles for a complete set of rules governing the waters in which you will be using your boat.

### STEERING AND SAILING RULES AND SOUND SIGNALS

Whenever two vessels on the water meet one another, one vessel has the right-of-way; it is called the "stand-on" vessel. The vessel which does not have the right-of-way is called the "give-way" or "burdened" vessel. These rules determine which vessel has the right-of-way, and what each vessel should do.

#### Stand-on vessel

The vessel with the right-of-way has the duty to continue its course and speed, except to avoid an immediate collision. When you maintain your direction and speed, the other vessel will be able to determine how best to avoid you.

#### Give-way vessel

The vessel which does not have the right-of-way has the duty to take positive and timely action to stay out of the way of the Stand-On vessel. Normally, you should not cross in front of the vessel with the right-of-way. You should slow down or change directions briefly and pass behind the other vessel. You should always move in such a way that the operator of the other vessel can see what you are doing.

#### "The general prudential rule"

This rule is called Rule 2 in the International Rules and says,

'In obeying and construing these rules due regard shall be had to all dangers of navigation and collision, and to any special circumstances, which may render a departure from the above rules necessary in order to avoid immediate danger.'

In other words, follow the standard rules except when a collision will occur unless both vessels try to avoid each other. If that is the case, both vessels become "Give-Way" vessels.



### RULES WHEN ENCOUNTERING VESSELS

There are three main situations which you may encounter with other vessels which could lead to a collision unless the Steering Rules are followed:

#### Meeting

(you are approaching another vessel head-on)

#### Crossing

(you are traveling across the other vessel's path)

#### Overtaking

(you are passing or being passed by another vessel)

In the following illustration, your boat is in the center. You should give the right-of-way to any vessels shown in white area (you are the Give-Way vessel). Any vessels in the shaded area must yield to you (they are the Give-Way vessels). Both you and the meeting vessel must alter course to avoid each other.

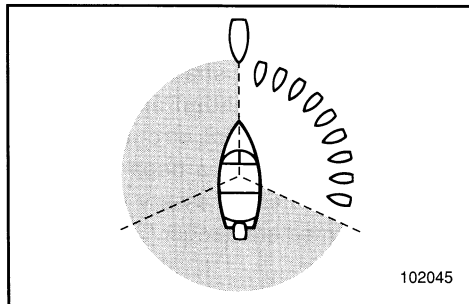

#### Meeting

If you are meeting another power vessel head on, and are close enough to run the risk of collision, neither of you has the right-of-way! Both of you should alter course to avoid an accident. You should keep the other vessel on your port (left)

side. This rule doesn't apply if both of you will clear one another if you continue on your set course and speed.

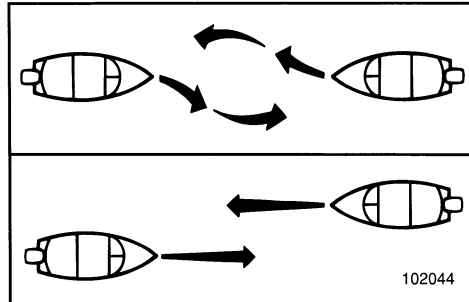

#### Crossing

When two power driven vessels are crossing each other's path close enough to run the risk of collision, the vessel which has the other on the starboard (right) side must keep out of the way of the other. If the other vessel is on your right, you must keep out of its way; you are the Give-Way vessel. If the other vessel is on your port (left) side, remember that you should maintain course and direction, provided the other vessel gives you the right-of-way as it should.

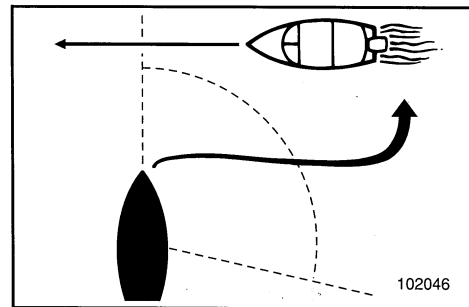

#### Overtaking

If you are passing another vessel, you are the "Give-Way" vessel. This means that the other vessel is expected to maintain its course and speed. You must stay out



of its way until you are clear of it. Likewise, if another vessel is passing you, you should maintain your speed and direction so that the other vessel can steer itself around you.

### **OTHER SPECIAL SITUATIONS**

There are three other rules you should be aware of when driving your boat around other vessels.

#### **Narrow channels and bends**

When navigating in narrow channels, you should keep to the right when it is safe and practical to do so. If the operator of a power-driven vessel is preparing to go around a bend that may obstruct the view of other water vessels, the operator should sound a prolonged blast on the whistle (4 to 6 seconds). If another vessel is around the bend, it too should sound the whistle. Even if no reply is heard, however, the vessel should still proceed around the bend with caution. If you navigate such waters with your boat, you will need to carry a portable air horn, available from local marine supply stores.

#### **Fishing vessel right-of-way**

All vessels which are fishing with nets, lines or trawls are considered to be "fishing vessels" under the International Rules. Vessels with trolling lines are not considered fishing vessels. Fishing vessels have the right-of-way regardless of position. Fishing vessels cannot, however, impede the passage of other vessels in narrow channels.

#### **Sailing vessel right-of-way**

Sailing vessels should normally be given the right-of-way. The exceptions to this are:

1. When the sailing vessel is overtaking

the power-driven vessel, the power-driven vessel has the right-of-way.

2. Sailing vessels should keep clear of any fishing vessel.
3. In a narrow channel, a sailing vessel should not hamper the safe passage of a power-driven vessel which can navigate only in such a channel.

#### **Reading buoys and other markers**

The waters of the United States are marked for safe navigation by the lateral system of buoyage. Simply put, buoys and markers have an arrangement of shapes, colors, numbers and lights to show which side of the buoy a boater should pass on when navigating in a particular direction. The markings on these buoys are oriented from the perspective of being entered from seaward (the boater is going towards the port). This means that red buoys are passed on the starboard (right) side when proceeding from open water into port, and black buoys are to port (left) side. When navigating out of port, your position with respect to the buoys should be reversed; red buoys should be to port and black buoys to starboard.

Many bodies of water used by boaters are entirely within the boundaries of a particular state. The Uniform State Waterway Marking System has been devised for these waters. This system uses buoys and signs with distinctive shapes and colors to show regulatory or advisory information. These markers are white with black letters and orange borders. They signify speed zones, restricted areas, danger areas, and general information.



Remember, markings may vary by geographic location. Always consult local boating authorities before driving your boat in unfamiliar waters.

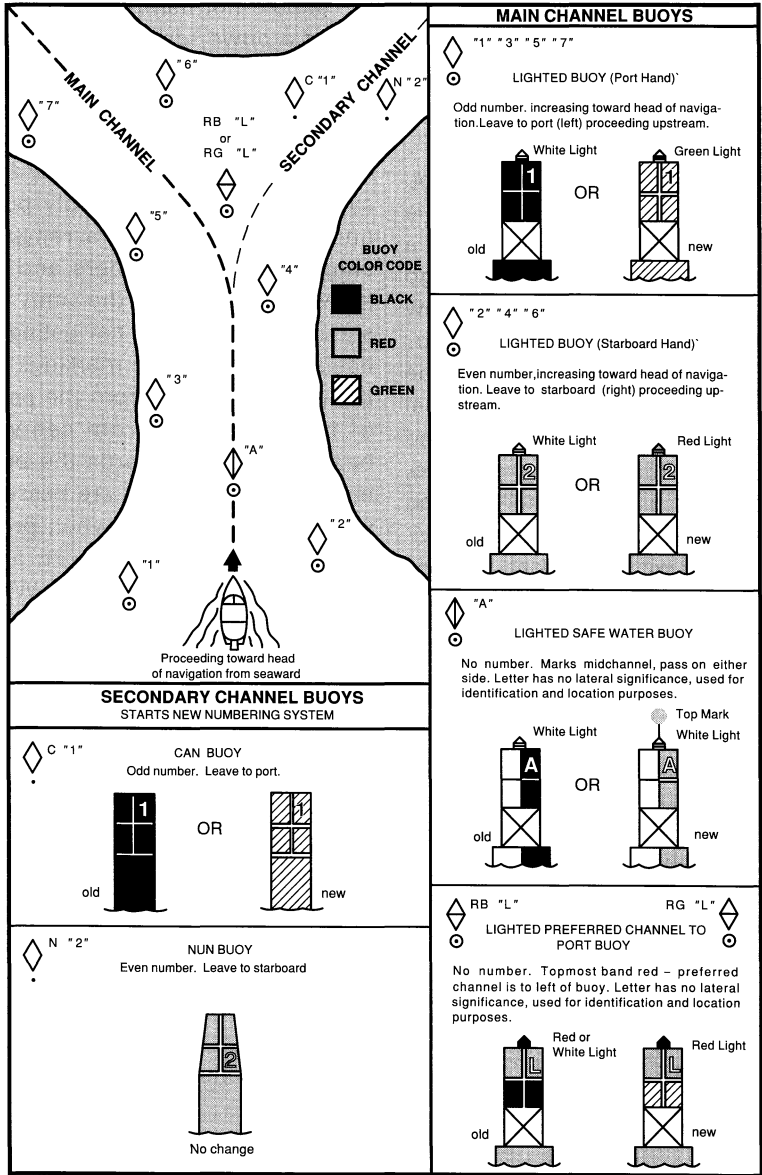

102052





EMU00017

## FUELING INSTRUCTIONS

### **⚠ WARNING**

**GASOLINE AND ITS VAPORS ARE HIGHLY FLAMMABLE AND EXPLOSIVE!**

- Do not smoke when refueling, and keep away from sparks, flames, or other sources of ignition.
- Stop engine before refueling.
- Refuel in a well-ventilated area. Refuel portable fuel tanks off the boat.
- Take care not to spill gasoline. If gasoline spills, wipe it up immediately with dry rags.
- Do not overfill the fuel tank.
- Tighten the filler cap securely after refueling.
- If you should swallow some gasoline inhale a lot of gasoline vapor, or get gasoline in your eyes, get immediate medical attention.
- If any gasoline spills onto your skin, immediately wash with soap and water. Change clothing if gasoline spills on it.
- Touch the fuel nozzle to the filler opening or funnel to help prevent electrostatic sparks.

### **CAUTION:**

- Use only new clean gasoline which has been stored in clean containers and is not contaminated with water or foreign matter.
- Do not use leaded gasoline (petrol). Leaded gasoline will cause damage to the oxygen sensor for Electronic Fuel Injection system.



EMU00019

**GASOLINE (PETROL)**

Recommended gasoline:  
Regular unleaded gasoline with a  
minimum octane rating of 86  
(Pump Octane Number) = (R+M)/2

If knocking or pinging occurs, use a different brand of gasoline or premium unleaded fuel.

EMU00027

**Gasohol**

There are two types of gasohol: gasohol containing ethanol and that containing methanol. Gasohol containing ethanol can be used if ethanol content does not exceed 10% and the fuel meets minimum octane ratings. Gasohol containing methanol is not recommended by Yamaha because it can cause fuel system damage or engine performance problems.

EMU00858

**ENGINE OIL**

Recommended engine oil:  
YAMALUBE 2 STROKE OUTBOARD OIL

If the recommended engine oil is not available, another 2-stroke engine oil with a NMMA-certified TC-W3 rating may be used.



EMU00031

## BATTERY REQUIREMENT

**CAUTION:**

Do not use the battery that does not meet the specified capacity. If different battery from the specification is used, the electric system may perform poorly or be overloaded, causing electrical system damage.

Choose battery which meets the following specifications for Electric start model.

Minimum cold crank performance 512 Amps at -17.8°C (0°F) Minimum reserve capacity 182 minutes at 26.7°C (80°F)
---

EMU00035

## PROPELLER SELECTION

The performance of your outboard motor will be critically affected by your choice of propeller, for an incorrect one could adversely affect performance and could seriously damage the motor. The engine speed depends on the propeller size and the boat load. If the engine speed is too high or too low for good engine performance, this will have an adverse effect on the engine.

Yamaha outboard motors are fitted with propellers chosen to perform well over a range of applications, but there may be uses where a propeller with a different pitch would be better. For a greater operating load, a smaller-pitch propeller is more suitable as it enables the correct engine speed to be maintained. Conversely, a larger-pitch propeller is more suitable for a smaller operating load.



Yamaha dealers stock a range of propellers, and can advise you and install a propeller on your outboard that is best suited to your application.

**NOTE:**

Select a propeller which will allow the engine to reach the middle or upper half of the operating range at full throttle with the maximum boat load. If operating conditions such as light boat loads then allow the engine rpm to rise above the maximum recommended range, reduce the throttle setting to maintain the engine in the proper operating range.

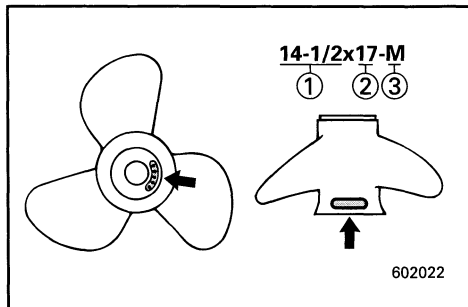

Recommended full throttle operating range;  
Refer to SPECIFICATIONS, Page 4-1.

- ① Propeller diameter (in inches)
- ② Propeller pitch (in inches)
- ③ Type of propeller (Propeller mark)

Propeller removal and installation; Refer to propeller checking section in Chapter 4.

EMU00901

**START-IN-GEAR PROTECTION**

Yamaha outboard motor has the start-in-gear protection device(s). This feature permits the engine to be started only when it is Neutral. Always select Neutral before starting the engine.

EMU00037

## Chapter 2

### BASIC COMPONENTS

MAIN COMPONENTS.....2-1

#### OPERATIONS OF CONTROLS AND

OTHER FUNCTIONS .....2-2

Remote control .....2-2

Trim tab .....2-7

Power trim and tilt switch .....2-8

Digital tachometer.....2-9

Digital speedometer.....2-10

Fuel management meter .....2-13

Tilt support lever .....2-17

Top cowling lock levers .....2-17

**WARNING SYSTEM** .....2-18

Overheat warning.....2-18

Oil level warning / Oil filter clogging  
warning .....2-19

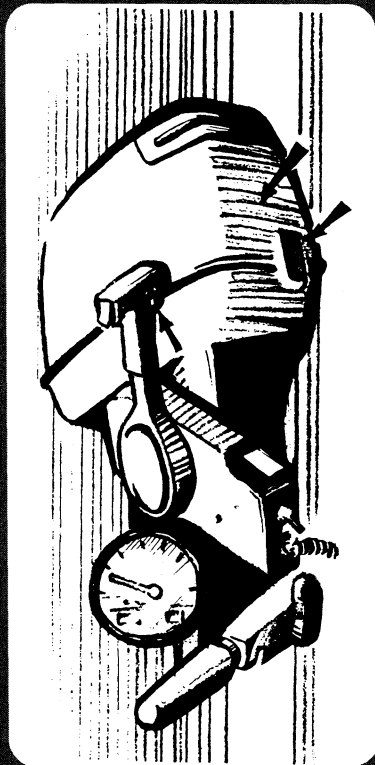
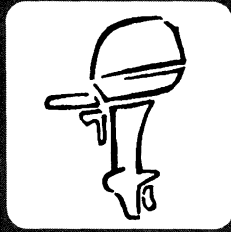



EMU00038

### MAIN COMPONENTS

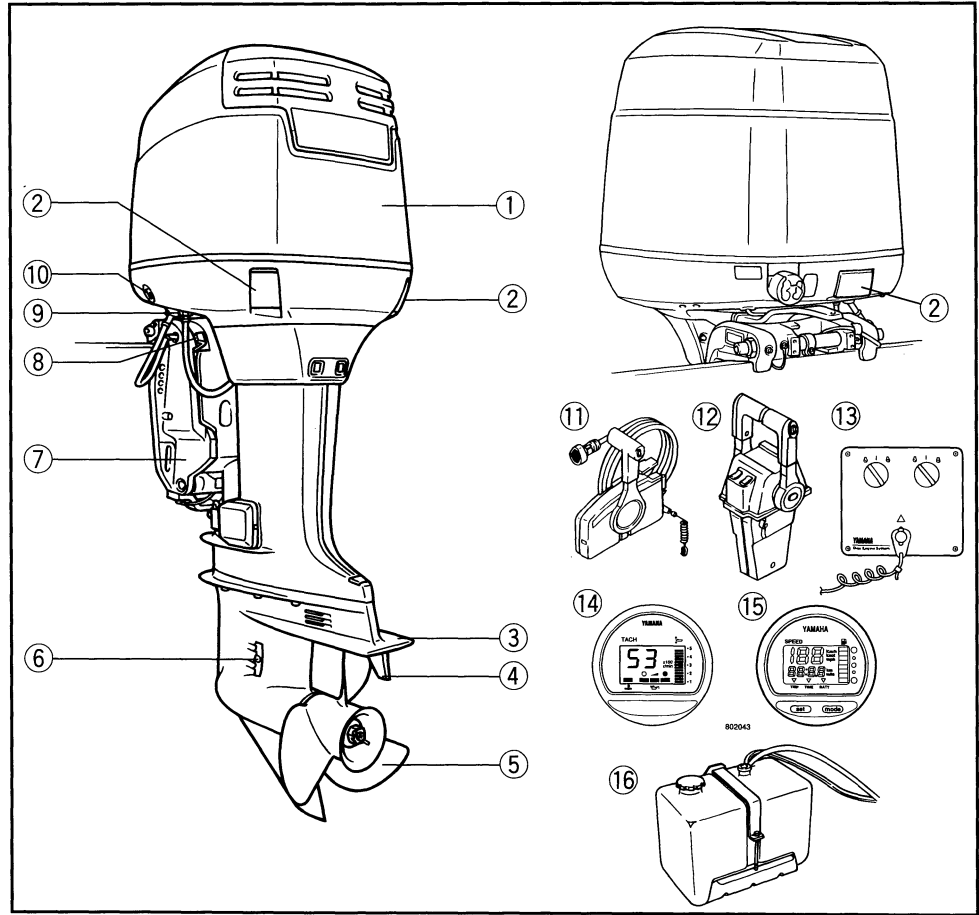

- ① Top cowling
- ② Top cowling lock levers
- ③ Anti-cavitation plate
- ④ Trim tab (Anode)
- ⑤ Propeller
- ⑥ Cooling water inlet
- ⑦ Clamp bracket
- ⑧ Tilt support lever
- ⑨ Flushing device
- ⑩ Power trim and tilt switch
- \* ⑪ Remote control box (Side mount type)
- \* ⑫ Remote control box (Binnacle mount type)
- \* ⑬ Switch panel (Together with ⑫)
- ⑭ Digital tachometer
- ⑮ Digital speedometer
- \* ⑯ Remote oil tank

\* It differs on specifications.

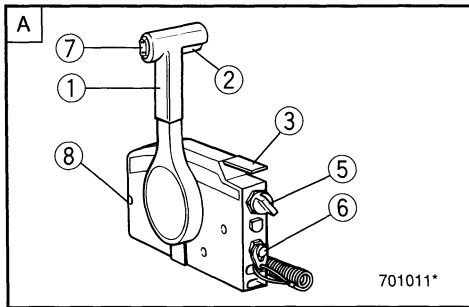

EMU00039

## OPERATIONS OF CONTROLS AND OTHER FUNCTIONS

EMU00097

### REMOTE CONTROL

Both the shifter and the throttle are actuated by the remote control lever. In addition, this remote control also has the electrical switches.

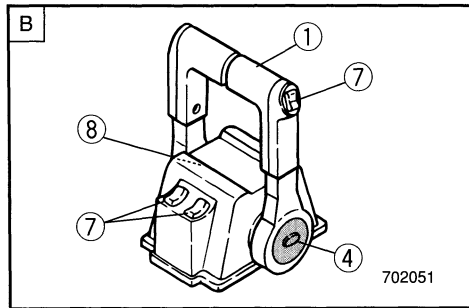

- [A] Side mount remote control box
- [B] Binnacle mount remote control box
- [C] Switch panel (Together with [B])

- ① Remote control lever
- ② Neutral interlock trigger
- ③ Neutral throttle lever
- ④ Free accelerator
- ⑤ Main switch
- ⑥ Engine stop lanyard switch
- ⑦ Power trim/tilt switch
- ⑧ Throttle friction adjusting screw

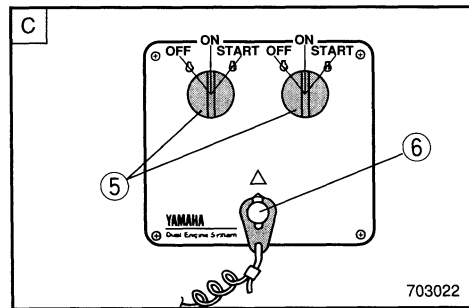

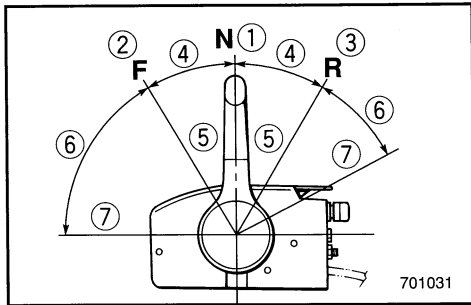

EMU00098

**Remote Control Lever**

Moving the lever forward from the Neutral position engages Forward gear. Pulling the lever back from Neutral engages Reverse. The engine will continue to run at idle until the lever is moved about 35° (a detent can be felt). Moving the lever farther opens the throttle, and the engine will begin to accelerate.

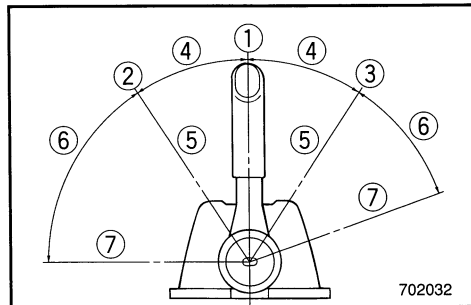

- ① Neutral
- ② Forward
- ③ Reverse
- ④ Shift
- ⑤ Fully closed
- ⑥ Throttle
- ⑦ Fully open

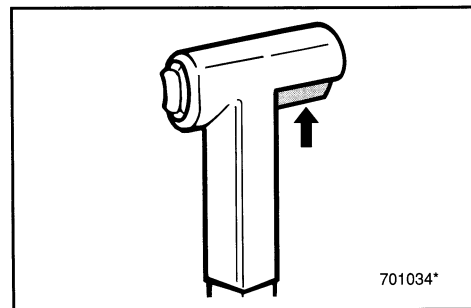

EMU00099

**Neutral Interlock Trigger**

To shift out of Neutral, the neutral interlock trigger of the remote control lever must first be pulled up.

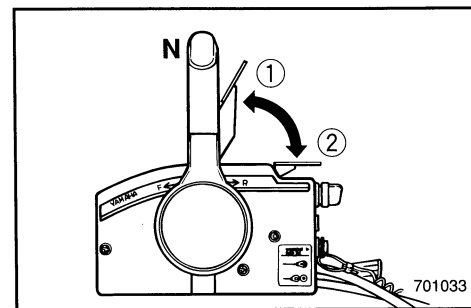

EMU00100

**Neutral Throttle Lever**

To open the throttle without shifting into either Forward or Reverse, place the remote control lever in the Neutral position and lift the neutral throttle lever.

**NOTE:** \_\_\_\_\_  
 The neutral throttle lever will operate only when the remote control lever is in Neutral. The remote control lever will operate only when the neutral throttle lever is in the closed position.

- ① Fully open
- ② Fully closed



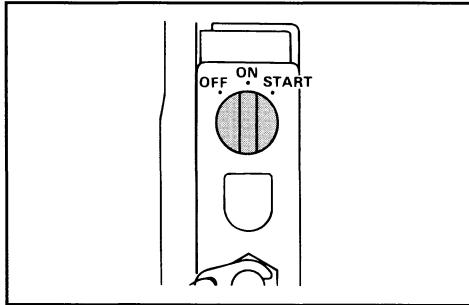

EMU00101

**Main switch**

The main switch controls the ignition system; its operation is described below.

- **OFF**  
Electrical circuits switched off. (The key can be removed.)
- **ON**  
Electrical circuits switched on. (The key cannot be removed.)
- **START**

Starter-motor will turn and start engine. (When the key is released, it returns automatically to "ON".)

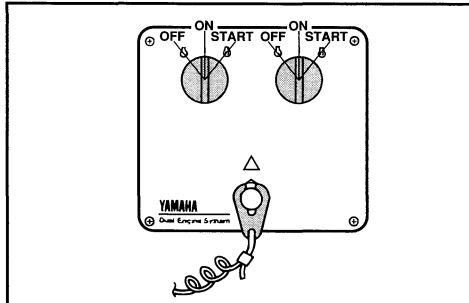

EMU00934

**Engine Stop Lanyard Switch**

The lock-plate ① must be attached to the engine stop lanyard switch for the engine to run. The lanyard ② should be attached to a secure place on the operator's clothing, or arm or leg. Should the operator fall overboard or leave the helm, the lanyard will pull out the lock plate, stopping ignition to the engine. This will prevent the boat from running away under power.

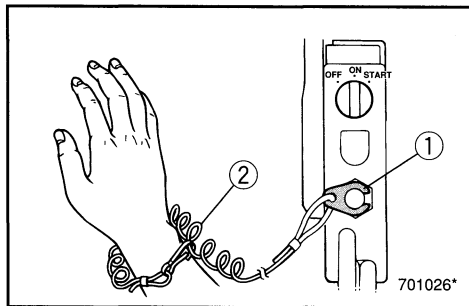

701026\*

**⚠ WARNING**

- **Attach the lanyard to a secure place on your clothing, your arm or leg while operating.**
- **Do not attach the lanyard to clothing that could tear loose. Do not route the lanyard in such a way that it could become entangled, preventing it from functioning.**
- **Avoid accidentally pulling the lanyard during normal operation. Loss of engine power means the loss of most steering control. Also, without engine power, the boat could slow rapidly. This could cause people and objects in the boat to be thrown forward.**

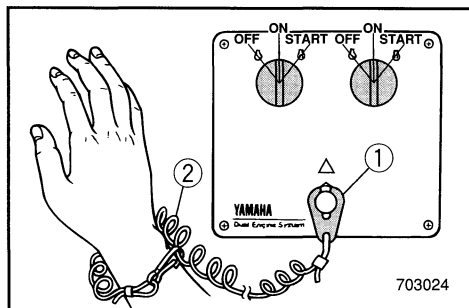

703024



**NOTE:** \_\_\_\_\_  
The engine cannot be started with the lock-plate removed.  
\_\_\_\_\_

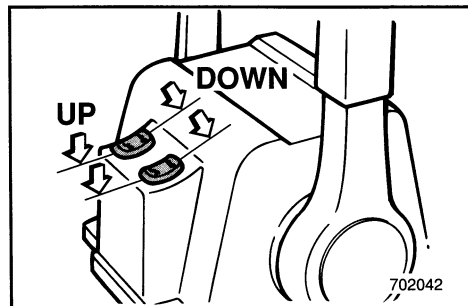
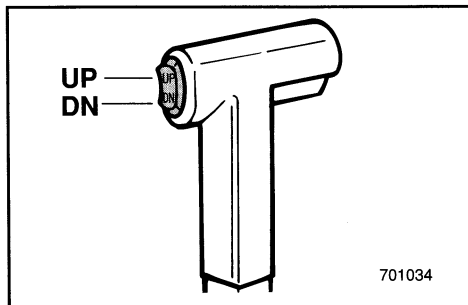

EMU00105

**Power Trim/Tilt Switches**

The power trim/tilt adjusts the motor angle in relation to the transom. The power trim/tilt switch is located on the remote control lever grip. Individual-engine switches are also on the control cover. Pushing the switch UP trims the motor up, then tilts the motor up. Pressing the switch DN tilts the motor down and trims the motor down. When the switch button is released, the motor will stop in its current position.

**NOTE:** \_\_\_\_\_  
On the dual engine control, the switch on the remote control grip controls both engines at the same time.  
\_\_\_\_\_

**⚠ WARNING** \_\_\_\_\_

**Excessive trim for the operating conditions (either trim up or down) can cause boat instability and can make steering the boat more difficult. This increases the possibility of an accident. If the boat begins to feel unstable or is hard to steer, slow down and/or readjust the trim angle.**  
\_\_\_\_\_

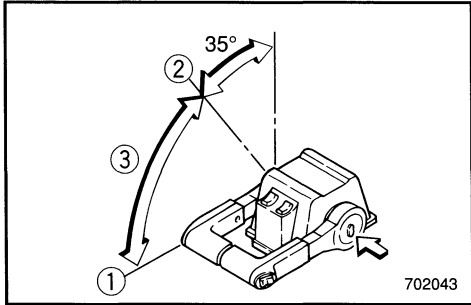

EMU00106

**Free Accelerator**

To open the throttle without shifting into either Forward or Reverse, push the free accelerator button and turn the remote control lever.

**NOTE:**

- The free accelerator button can be operated only when the remote control lever is in the Neutral position.
- After the button is pushed, the remote control lever must be moved at least 35° to begin opening the throttle.
- After operating the free accelerator, return the remote control lever to the Neutral position. The free accelerator button will return automatically to its set position. The remote control will then engage Forward and Reverse normally.

- ① Fully-open
- ② Fully-closed
- ③ Free accelerator

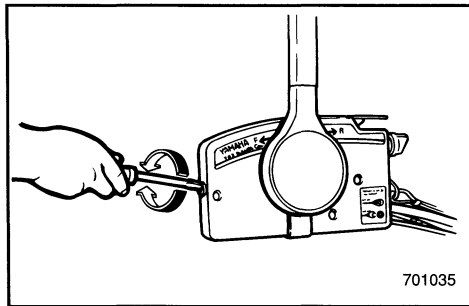

EMU00107

**Throttle Friction Adjusting Screw**

A friction device in the remote control box provides resistance to movement of the remote control lever. This is adjustable for operator preference. An adjusting screw is located at the front of the remote control box.

Resistance	Screw
Increase	Turn to clockwise
Decrease	Turn to counterclockwise

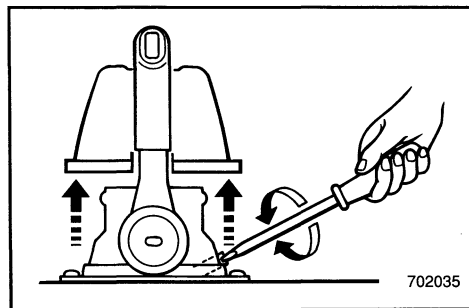

**⚠ WARNING**

**Do not overtighten the friction adjusting screw. If there is too much resistance, it may be difficult to move the lever, which could result in an accident.**



EMU00113

**TRIM TAB**

The trim tab should be adjusted so that the steering control can be turned to either the right or left by applying the same amount of force.

**⚠ WARNING**

An improperly adjusted trim tab may cause difficult steering. Always test run after the trim tab has been installed or replaced to be sure steering is correct. Be sure you have tightened the bolt after adjusting the trim tab.

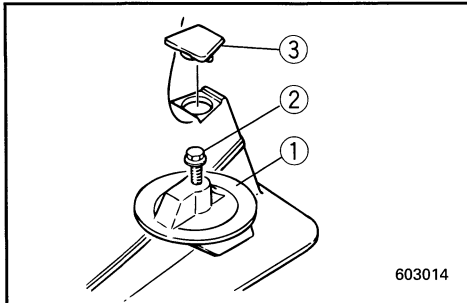

- ① Trim tab
- ② Bolt
- ③ Cap (If equipped)

Boat tends to veer	The fin of trim tab
To the left (port side)	Turn to the left (A in the figure)
To the right (starboard side)	Turn to the right (B in the figure)

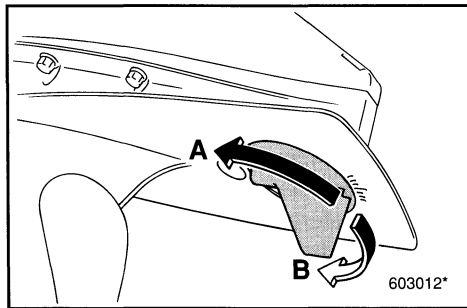

**CAUTION:**

The trim tab also serves as an anode to protect the engine from electrochemical corrosion. Never paint the trim tab as it will become ineffective as an anode.



E

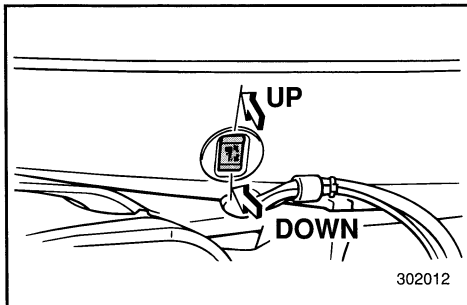

EMU00119

### POWER TRIM/TILT SWITCH

The power trim/tilt adjusts the motor angle in relation to the transom. The power trim/tilt switch is located on the port side of the bottom engine cowling. Pushing the switch "UP" trims the motor up, then tilts the motor up. Pressing the switch "DN" tilts the motor down and trims the motor down. When the switch button is released, the motor will stop in its current position.

#### **⚠ WARNING**

**Excessive trim for the operating conditions (either trim up or down) can cause boat instability and can make steering the boat more difficult. This increases the possibility of an accident. If the boat begins to feel unstable or is hard to steer, slow down and/or readjust the trim angle.**

#### **NOTE:**

Another power trim/tilt switch is provided with this model for remote installation. This switch has the same function as the switch equipped on the engine.

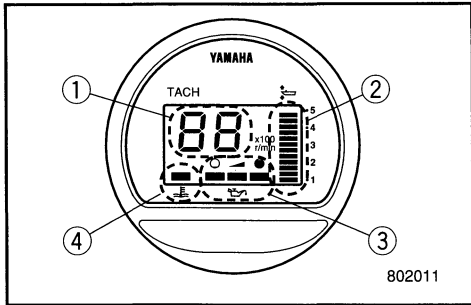

EMU00135

### DIGITAL TACHOMETER

This meter contains the tachometer, trim meter, oil level warning and overheat warning.

- ① Tachometer
- ② Trim meter
- ③ Oil level warning indicator
- ④ Overheat warning indicator

#### NOTE:

After the main switch is first turned on all portions of the meter come on as a check. The tachometer and trim meter will indicate the maximum reading and the oil level warning indicator and overheat warning indicator will light. After a few seconds, the meters will change to normal operation. Watch the meter when turning on the main switch to make sure all segments come on.

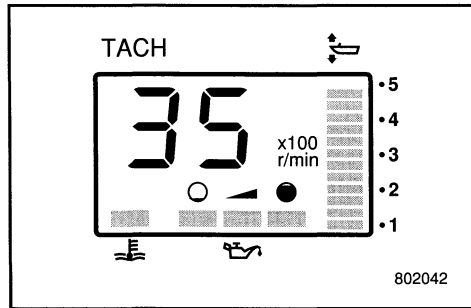
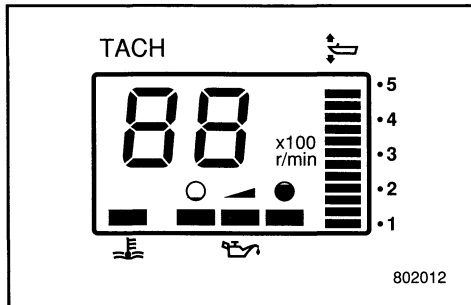

EMU00136

#### Tachometer

This meter shows the engine speed.

EMU01109

#### Trim Meter

This meter shows the trim angle of your outboard motor.

#### NOTE:

- Memorize the trim angles that work best for your boat under different conditions. Adjust the trim angle to the desired setting by operating the power trim and tilt switch.
- If the trim angle of your motor exceeds the trim operating range, the top segment on the trim meter display will start to blink.

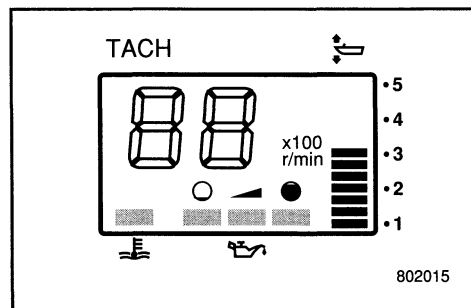

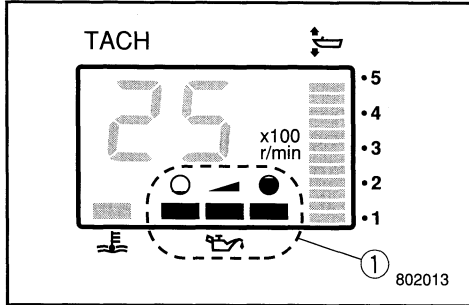

EMU00138

**Oil-Level Warning Indicator**

If oil level falls below the lower limit, the warning indicator will start to blink. Refer to "OIL LEVEL WARNING" for the detail.

- ① Oil-level warning indicator

**CAUTION:**

**Do not operate the engine without oil. Serious engine damage will occur.**

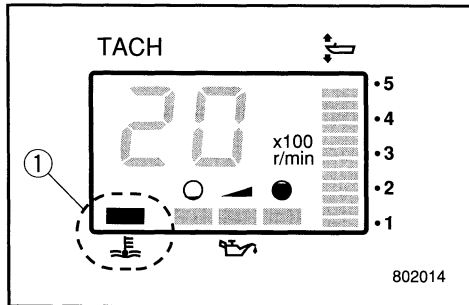

EMU00139

**Overheat Warning Indicator**

If the engine temperature rises too high, the warning indicator will start to blink. Refer to "OVERHEAT WARNING" for the detail.

- ① Overheat warning indicator

**CAUTION:**

**Do not continue to operate the engine if a warning device has activated. If necessary, refer to the "TROUBLESHOOTING" section in this manual. Consult your dealer if the problem cannot be located and corrected.**

EMU00140

**DIGITAL SPEEDOMETER**

This meter contains the speedometer, fuel meter with warning, trip meter, clock and voltmeter with warning.

- ① Speedometer
- ② Fuel meter
- ③ Trip meter/clock/voltmeter
- ④ Warning indicator

**NOTE:**

After the main switch is first turned on, all portions of the meter come on as a check. After a few seconds, the meters will change to normal operation. Watch the meter when turning on the main switch to make sure all segments come on.

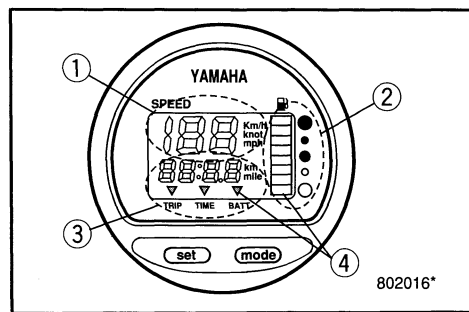

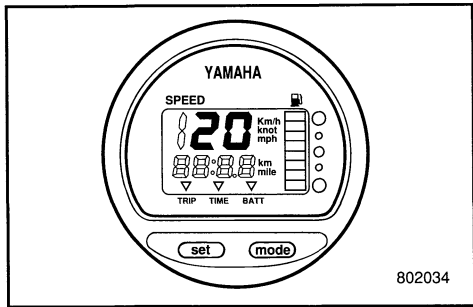

802034

EMU00141

### Speedometer

The meter will show the boat speed.

#### NOTE:

The speedometer displays km/h, mph, or knots, depending upon operator preference. Select the desired unit of measurement by setting the selector switch on the back of the meter. See the illustration for setting.

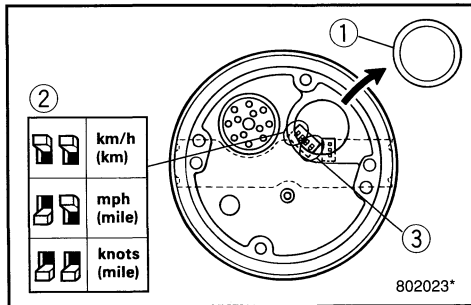

802023\*

- ① Cap
- ② Selector switch (For speed unit)
- ③ Selector switch (For fuel sender)

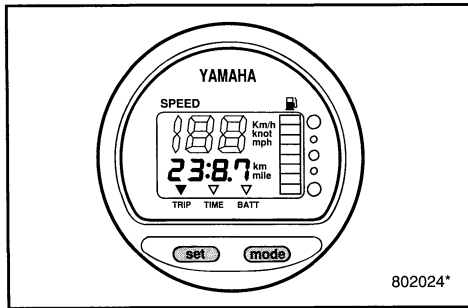

802024\*

EMU00142

### Trip Meter

Push and release the "mode" button until the indicator on the face of the meter points to "TRIP". The meter will display the distance the boat has traveled since the meter was last reset. To reset the trip meter to "0", press the "set" and "mode" button together.

#### NOTE:

- The trip distance will be shown in kilometers or miles depending upon the unit of measurement selected for the speedometer.
- The trip distance is kept in memory by battery power. The stored data will be lost if the battery is disconnected.





E

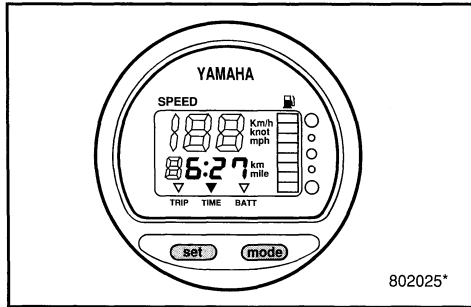

EMU00143

### Clock

Push and release the "mode" button until the indicator on the face of the meter points to "TIME." The meter will indicate time.

To set the clock, be sure the meter is in the "TIME" mode. Press the "set" button; the hour display will begin blinking. Press the "mode" button until the desired hour is displayed. Press the "set" button again, the minute display will begin blinking. Press the "mode" button until the desired minute is displayed. Press the "set" button again to start the clock.

### NOTE:

The clock operates on battery power. Disconnecting the battery will stop the clock. Reset the clock after connecting the battery.

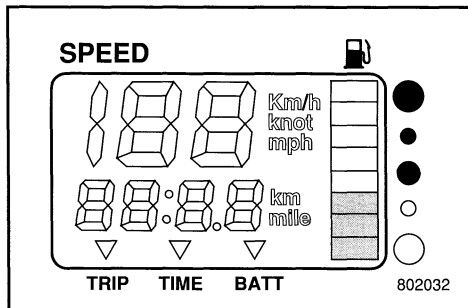

EMU00144

### Fuel meter

The fuel level is displayed by eight segments. When all segments are showing, the fuel is full.

### CAUTION:

**The Yamaha fuel tank sensor is different from a conventional-type sensor. A wrong setting of the selector switch on the meter will give incorrect readings. Consult Yamaha dealer for correct setting.**

### NOTE:

The fuel reading can be affected by the position of the sensor in the fuel tank and the attitude of the boat in the water. Operation with bow-up trim or continuous turning can give false readings.



E

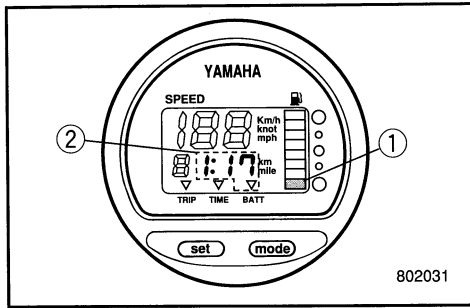

EMU00145

### Warning indicator

#### • Fuel warning

If the fuel level decreases to one segment ① begins blinking.

#### • Low battery voltage warning

If battery voltage drops, the display ② will be automatically turned on and it begins blinking.

### CAUTION:

**Do not continue to operate the engine if a warning device has activated. Refer to the TROUBLESHOOTING section in this manual. Consult a Yamaha dealer if the problem cannot be located and corrected.**

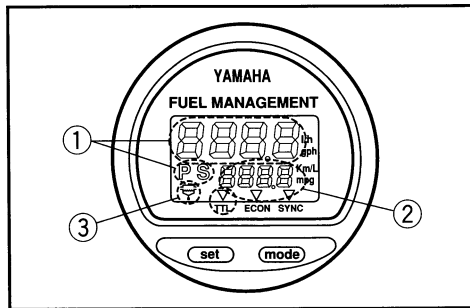

EMU00146

### FUEL MANAGEMENT METER

#### Optional equipment

The meter contains the fuel flow meter, fuel consumption meter, fuel economy meter, twin engine speed synchronizer, water separator warning indicator.

- ① Fuel flow meter
- ② Fuel consumption / Fuel economy meter / Twin engine speed synchronizer
- ③ Water separator warning indicator (Operates only if the sensor has been installed.)

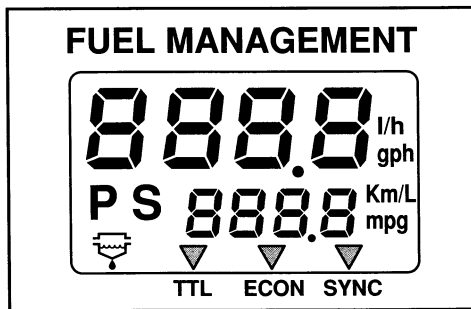

### NOTE:

After the main switch is first turned on, all portions of the meter come on as a check. After a few seconds, the meters will change to normal operation. Watch the meter when turning on the main switch to make sure all segments come on.

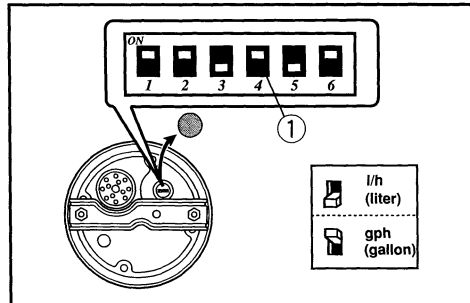
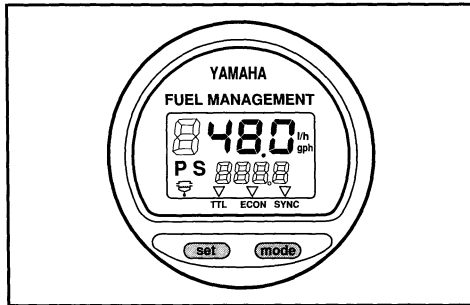
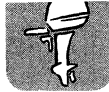

EMU00147

**Fuel Flow Meter**

The meter displays fuel flow within one hour, at the rate of current engine operation.

If twin engines are installed on your boat, the meter will display total fuel flow of Port and Starboard side engine. It also displays PS indication at the same time.

By pressing "set" button, the meter will display fuel flow of starboard side engine and S indication.

By pressing "set" button again, the meter will display fuel flow of port side engine and P indication.

By pressing "set" button again, the meter will display total fuel flow.

**NOTE:**

- The meter displays gallon/hour and liter depending upon operator preference. Select the desired unit of measurement by setting the selector switch ① on the back of the meter during installation.
- Fuel consumption meter and Fuel economy meter will indicate same unit of measurement.

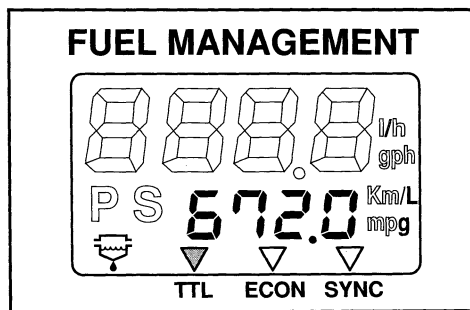

EMU00148

**Fuel Consumption Meter**

Push and release the "mode" button until the indicator on the face of the meter points to total ("TTL"). The meter will display the total amount of fuel consumed after the meter was last reset. To reset the total fuel consumption to "0", press the "set" and "mode" buttons together.

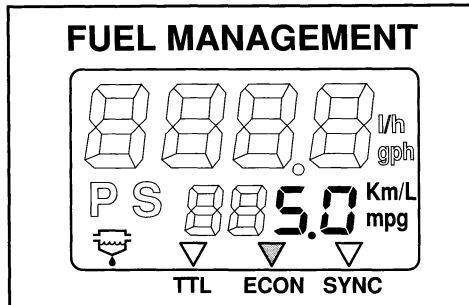

EMU00149

**Fuel Economy**

Push and release the "mode" button until the indicator on the face of the meter points to "ECON." The meter will display the distance per liter or gallon for the operator's reference when cruising.

**NOTE:**

If twin engines are installed on your boat, the meter will display only the total fuel economy of both engines.

**NOTE:**

- Fuel consumption will vary greatly with boat design, weight, propeller used, engine trim angle, sea conditions (including wind), and throttle position. Fuel consumption will also vary slightly with the type of water (salt, fresh, and contaminate levels), air temperature and humidity, cleanliness of the boat bottom, engine mounting height, skill of the operator, and individual gasoline formulation (winter or summer fuel and amount of additives).
- The Yamaha digital speedometer and fuel management meter calculates speed, miles traveled, and fuel economy by water movement at the stern of the boat. This distance can vary greatly from the actual distance traveled because of water currents, sea swells, and the condition of the water speed sensor (partially plugged or damaged).
- Individual engines may slightly vary in their fuel consumption due to manufacturing variations. These variations can be even greater if the engines are of different year models. In addition, variations in propellers, even of the same basic dimensions of the same design, can also cause a slight variation in fuel consumption.

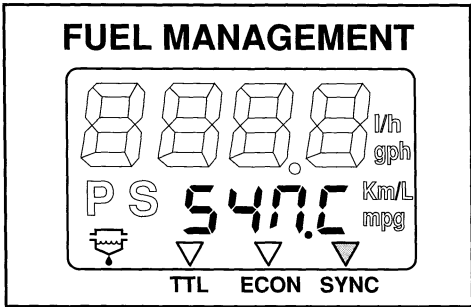

EMU00150

**Twin Engine Speed Synchronizer**

Push and release the "mode" button until the indicator on the face of the meter points to "SYNC". The meter will display the difference of engine speed (r/min) between Port and Starboard engines for the reference when synchronizing the two engine's speeds.

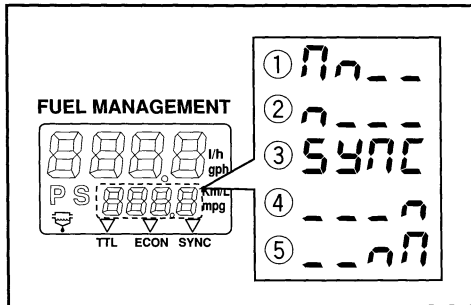

- ① Port side engine speed is higher
- ② Port side engine speed is slightly higher
- ③ Engine speed is synchronized evenly between Port and Starboard side engines
- ④ Starboard side engine speed is slightly higher
- ⑤ Starboard side engine speed is higher

**NOTE:**

If the two engine's speeds are not synchronized while cruising, they can be synchronized by adjusting trim angle or throttle.

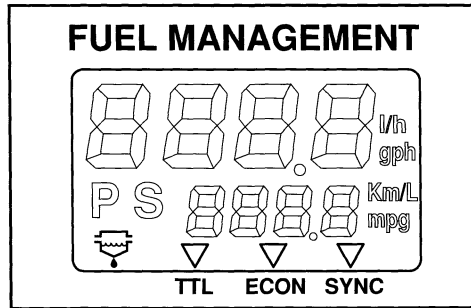

EMU00151

**Water Separator Warning Indicator**

If the water which has been separated from fuel in the water trap exceeds a specific volume, the indicator will blink showing the need for water to be drained.

**NOTE:**

This indicator operates only when an optional water separator sensor has been installed.



E

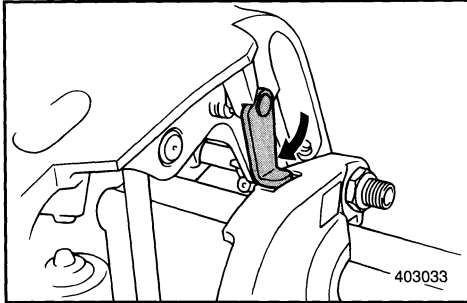

EMU00157

### TILT SUPPORT LEVER

To keep the outboard motor in the tilted-up position, lock the tilt support lever to the clamp bracket.

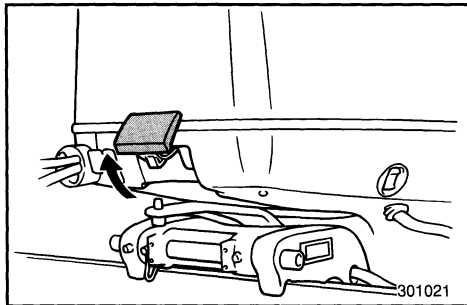

EMU00163

### TOP COWLING LOCK LEVERS

To remove the engine top cowling, pull up the front and rear lock levers. Then lift off the cowling. When replacing the cowling, check to be sure it fits properly in the rubber seal. Then lock the cowling again by moving the levers downward.

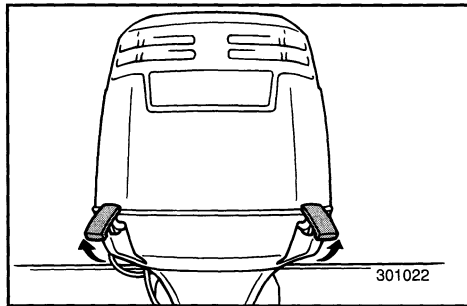

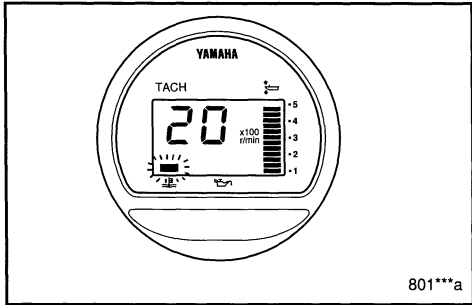

EMU00169

## WARNING SYSTEM

### CAUTION:

Do not continue to operate the engine if the warning device has activated. Consult your Yamaha dealer if the problem cannot be located and corrected.

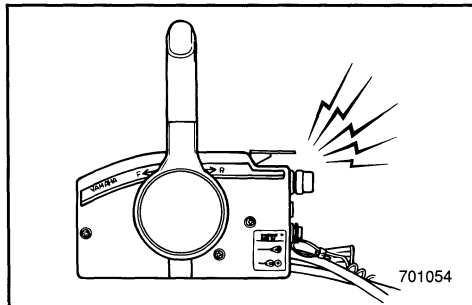

EMU00171

### OVERHEAT WARNING

This engine has an overheat warning device. If the engine temperature rises too high, the warning device will activate.

(○); Included (—); N/A

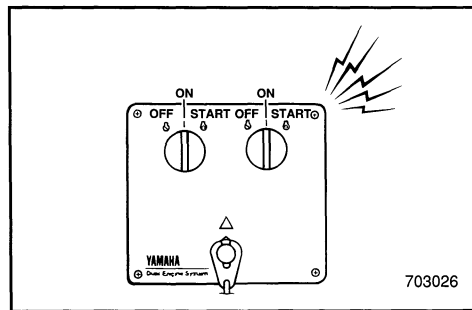

Warning device activation	Tiller control model	Remote control model
The engine speed will automatically decrease to about 2,000 r/min.	/	○
The overheat warning indicator will come on.	/	○
The buzzer will sound.	/	○

If the warning system has been activated, stop the engine and check the water inlet for clogging.

### NOTE:

In case of dual engine drive; Should the overheat warning system of one engine operate, it slows down and the buzzer sounds. This will cause the other engine to slow down and the buzzer to sound. For the other engine, the warning system can be released by shifting the remote control lever into the neutral.

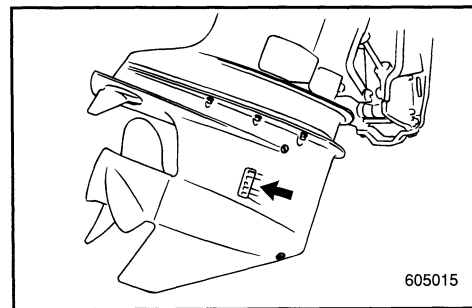



EMU00172

**OIL LEVEL WARNING / OIL FILTER CLOGGING WARNING**

This engine has an oil level warning system. If oil level falls below lower limit, the warning device will activate.

(○); Included (—); N/A

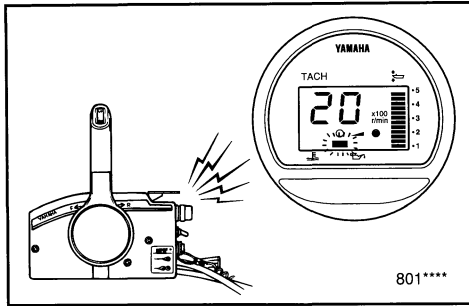

801\*\*\*\*

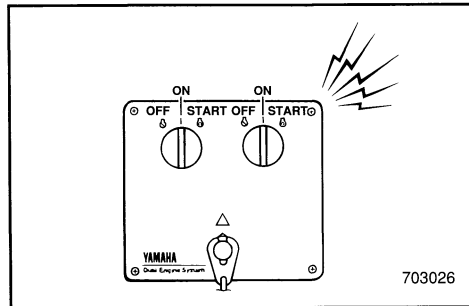

703026

Warning device activation	Tiller control model	Remote control model
The engine speed will automatically decrease to about 2,000 r/min.	/	○
The oil level warning indicator will come on.	/	○
The buzzer will sound.	/	○

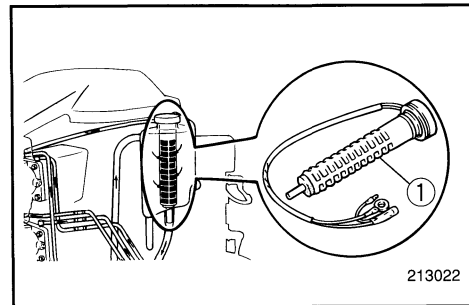

213022

If the warning system has been activated, stop the engine and check for the cause.

**NOTE:**

The warning for oil filter clogging is similar to the warnings for low oil level and overheating. For easy troubleshooting, it is advisable to check for engine overheating first, then oil level and finally oil filter clogging.

① Oil filter

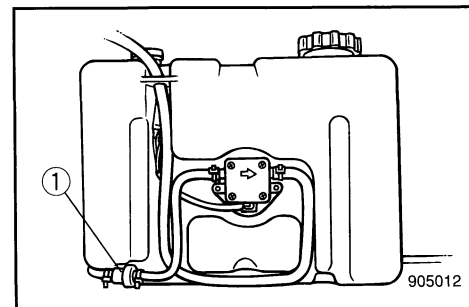

905012



EMU00174

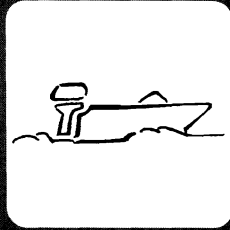

## Chapter 3

# OPERATION

<b>INSTALLATION</b> .....	3-1
Mounting the outboard motor .....	3-2
<b>FILLING FUEL AND ENGINE OIL</b> .....	3-4
Filling fuel .....	3-4
Filling oil .....	3-5
<b>PRE-OPERATION CHECKS</b> .....	3-8
Operation after a long period of storage .....	3-9
<b>BREAKING IN (RUNNING IN) ENGINE</b> .....	3-10
<b>STARTING ENGINE</b> .....	3-12
<b>WARMING UP ENGINE</b> .....	3-15
<b>SHIFTING</b> .....	3-16
<b>STOPPING ENGINE</b> .....	3-17
<b>TRIMMING OUTBOARD MOTOR</b> .....	3-18
Adjusting trim angle .....	3-19
<b>TILTING UP/DOWN</b> .....	3-21
<b>CRUISING IN OTHER CONDITIONS</b> .....	3-23
Cruising in salt water .....	3-23
Cruising in turbid water .....	3-23



## INSTALLATION

**CAUTION:** \_\_\_\_\_

**Incorrect engine height or obstructions to smooth water flow (such as the design or condition of the boat or accessories such as transom ladders/depth finder transducers) can create airborne water spray while the boat is cruising. Severe engine damage may result if the motor is operated continuously in the presence of airborne water spray.**

**NOTE:** \_\_\_\_\_

During water testing check the buoyancy of the boat, at rest, with its maximum load. Check that the static water level on the exhaust housing is low enough to prevent water entry into the powerhead, when water rises due to waves when the outboard is not running.



EMU00176

## MOUNTING THE OUTBOARD MOTOR

### **⚠ WARNING**

Improper mounting of the outboard motor could result in hazardous conditions such as poor handling, loss of control, or fire hazards. Observe the following:

- The information presented in this section is intended as reference only. It is not possible to provide complete instructions for every possible boat/motor combination. Proper mounting depends in part on experience and the specific boat/motor combination.
- Your dealer or other person experienced in proper rigging should mount the motor. If you are mounting the motor yourself, you should be trained by an experienced person. [permanent mounted type]
- Your dealer or other person experienced in proper outboard motor mounting should show you how to mount your motor. [portable type]

Mount the outboard motor on the center line (keel line) of the boat, and ensure that the boat itself is well balanced. Otherwise, the boat will be hard to steer. For boats without a keel or which are asymmetrical, consult your dealer.

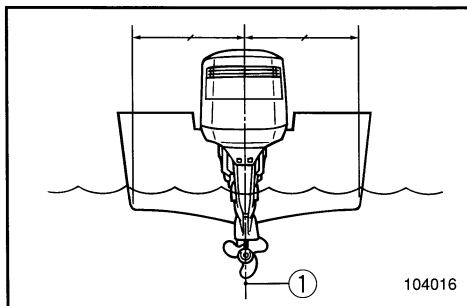

- ① Center line (keel line)

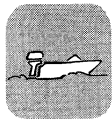
**⚠ WARNING**

Overpowering a boat may cause severe instability. Do not install an outboard motor with more horsepower than the maximum rating on the capacity plate of the boat. If the boat does not have a capacity plate, consult the boat manufacturer.

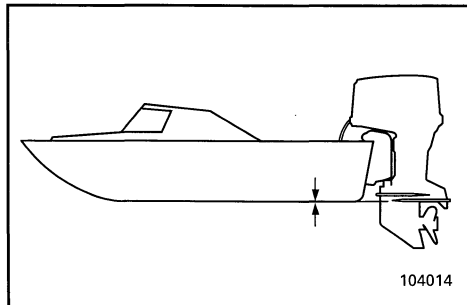

EMU00179

**Mounting Height**

To run your boat at optimum efficiency, the water-resistance (drag) of the boat and outboard motor must be made as little as possible. The mounting-height of the outboard motor greatly affects the water-resistance. If the mounting-height is too high, cavitation tends to occur, thus reducing the propulsion; and if the propeller tips cut the air, the engine speed will rise abnormally and cause the engine to overheat. If the mounting-height is too low, the water-resistance will increase and thereby reduce engine efficiency. Mount the engine so that the anti-cavitation plate is in alignment with the bottom of the boat.

**NOTE:**

The optimum mounting height of the outboard motor is affected by the boat/motor combination. Test runs at different heights can help determine the optimum mounting height.

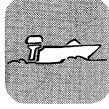

EMU00186

## FILLING FUEL AND ENGINE OIL

EMU00187

### FILLING FUEL

- 1) Remove the fuel tank cap.
- 2) Fill the fuel tank carefully.
- 3) Close the cap securely after refueling.  
Wipe up any spilled fuel.

Fuel tank capacity:  
Refer to SPECIFICATIONS, page 4-1.

EMU00189

### Ring Free Fuel Additive

Gasoline is a precise blend of many different substances, each chosen to give certain characteristics. Gasoline blends have been changing in recent years in response to concerns about pollution and resulting emissions regulations. One of the most obvious changes has been the elimination of lead from most fuels.

As gasoline has changed, the amount of additives such as aromatics and oxygenates has increased. These additives are important for the engines in passenger cars, but they can have detrimental effects in marine engines, particularly 2-cycle outboards because of increased deposits in the combustion chamber. When enough deposits collect, piston rings begin sticking. Performance drops and engine wear increases dramatically.

While many additives available may reduce deposits, Yamaha recommends the use of **Ring Free Fuel Additive**, available from your Yamaha dealer. Ring Free has repeatedly proven its ability to clean combustion deposits from inside the engine, notably the critical piston-ring-land area, and fuel system components. Follow product labeling for use instructions.



EMU00190

### FILLING OIL (for Precision blend system model)

This engine uses the YAMAHA PRECISION BLEND SYSTEM, which provides superior lubrication by ensuring the proper oil ratio for all operating conditions. No fuel premixing is needed (except during break-in/running-ins). Simply pour gasoline into the fuel tank and oil into the oil tank.

Convenient indicator segments indicate condition of the oil supply. Refer to "Oil level indicator".

To fill the engine oil into the engine oil tank, proceed as follows:

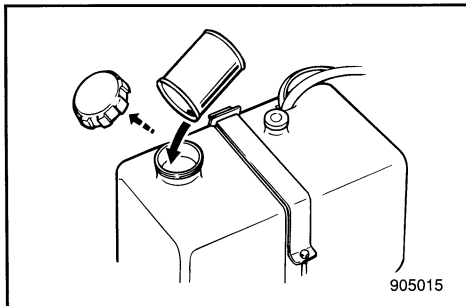

#### **⚠WARNING**

**Do not add gasoline (Petrol) into the oil tank. Fire or explosion could result.**

Engine oil tank capacity:  
Refer to "SPECIFICATION", page 4-1

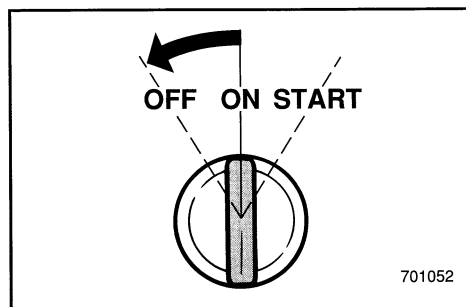
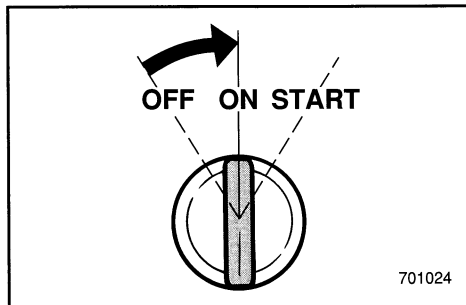

EMU00194

### When remote oil tank is used

- 1) Pour the engine oil into the remote oil tank.
- 2) Turn the main switch to "ON" to feed the oil automatically from the remote oil tank to the engine oil tank by the YAMAHA PRECISION BLEND SYSTEM.
- 3) After the engine oil tank is filled up with the oil, turn the main switch to "OFF" to cancel the operation of the oil level warning system.
- 4) Operate the engine normally.



E

---

**CAUTION:**

When the engine is operated for the first time or stored for a period of time, a minimum of 5 liters (5.3 US qt, 4.4 Imp qt) of oil should be kept in the remote oil tank. Otherwise, the oil-feed pump chamber will not be filled with oil, and no oil will be supplied.

---



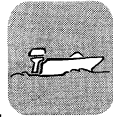

EMU00200

**Oil Level Indicator**

The various oil level system functions are as follows:

Oil level indicator (Digital tachometer)	Oil level indicator (Analog tachometer)	Engine oil tank	Remote oil tank	Remarks
	<p>Green</p>	<p>More than 300 cm<sup>3</sup> (0.32 US qt, 0.26 Imp qt)</p>	<p>More than 1,500 cm<sup>3</sup> (1.6 US qt, 1.31 Imp qt)</p>	<ul style="list-style-type: none"> <li>• No refilling necessary.</li> </ul>
	<p>Yellow</p>	<p>More than 300 cm<sup>3</sup> (0.32 US qt, 0.26 Imp qt)</p>	<p>1,500 cm<sup>3</sup> (1.6 US qt, 1.31 Imp qt) or less</p>	<ul style="list-style-type: none"> <li>• Add oil, refer to oil filling.</li> </ul>
	<p>Red Green</p>	<p>300 cm<sup>3</sup> (0.32 US qt, 0.26 Imp qt) or less</p>	<p>More than 1,500 cm<sup>3</sup> (1.6 US qt, 1.31 Imp qt)</p>	<ul style="list-style-type: none"> <li>• Check oil filter for clogging.</li> <li>• Check battery cable connection.</li> </ul>
	<p>Red</p>	<p>300 cm<sup>3</sup> (0.32 US qt, 0.26 Imp qt) or less</p>	<p>1,500 cm<sup>3</sup> (1.6 US qt, 1.31 Imp qt) or less</p>	<ul style="list-style-type: none"> <li>• Oil has not been added.</li> <li>• Buzzer will sound.</li> <li>• Engine speed is automatically reduced to about 2,000 r/min.</li> <li>• Refer to Chapter 5.</li> </ul>





EMU00204

## PRE-OPERATION CHECKS

### **⚠ WARNING**

If any item in the pre-operation check is not working properly, have it inspected and repaired before operating the outboard motor. Otherwise, an accident could occur.

### **CAUTION:**

Do not start the engine out of water. Overheating and serious engine damage can occur.

EMU00206

### **Fuel**

- Check to be sure you have plenty of fuel for your trip.
- Make sure there are no fuel leaks or gasoline fumes.
- Check fuel line connections to be sure they are tight.
- Be sure the fuel tank is positioned on a secure, flat surface, and that the fuel hose is not twisted or flattened, or likely to contact sharp objects.

EMU00207

### **Oil**

- Check to be sure you have plenty of oil for your trip.

EMU00209

### **Controls**

- Check throttle, shift, and steering for proper operation before starting the engine.
- The controls should work smoothly, without binding or unusual free play.
- Look for loose or damaged connections.
- Check operation of the starter and stop switches when the outboard motor is in the water.

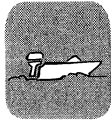

EMU00211

**Engine**

- Check the engine and engine mounting.
- Look for loose or damaged fasteners.
- Check the propeller for damage.
- Check that the battery is in good condition and battery connections are secure.

EMF44110

**OPERATION AFTER A LONG PERIOD OF STORAGE**

**(for Precision blend system model)**

When operating the engine after a long period (12 months) of storage, proceed as follows:

- 1) Use a 50 : 1 gasoline-oil mixture to start the engine.
- 2) Start the engine. Leave it idling.

**▲WARNING**

- Do not touch or remove electrical parts when starting or during operation.
- Keep hands, hair, and clothes away from flywheel and other rotating parts while engine is running.

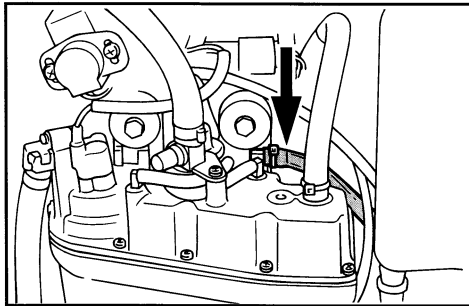

- 3) Watch for oil flowing through the oil feed pipes. After any air in the oil lines has been expelled, YAMAHA PRECISION BLEND SYSTEM should supply oil normally. If no oil has begun flowing after 10 minutes of idling, consult your Yamaha dealer.

**CAUTION:**

- When operating the engine after a long period of storage, be sure to take the above steps; otherwise, engine seizure may occur.
- After completing the above steps, use gasoline (petrol) only. If premix fuel is used continually, the oxygen sensor for Electronic Fuel Injection system could be damaged.



EMU00220

### BREAKING IN (RUNNING IN) ENGINE

Your new engine requires a period of break-in (running-in) to allow mating surfaces of moving parts to wear-in evenly. Correct break-in (running-in) will help ensure proper performance and longer engine life.

**CAUTION:**

- Failure to follow the break-in (running-in) procedure may result in reduced engine life or even severe engine damage.
- Premix fuel must be used during break-in (running-in) in addition to oil in the Precision Blend System.
- After break-in (running-in), use gasoline(petrol) only. If premix fuel is used continually, the oxygen sensor for Electronic Fuel Injection system could be damaged.

Break-in (running-in) time:10 hours

Break-in (running-in) premix ratio  
Gasoline (petrol) : Engine oil=50 : 1

EMU00225

#### Gasoline (Petrol)/ Engine oil mixing chart

Mixing ratio	50 : 1			
Gasoline (Petrol)	1 L (0.26 US gal, 0.22 Imp gal)	12 L (3.2 US gal, 2.6 Imp gal)	14 L (3.7 US gal, 3.1 Imp gal)	24 L (6.3 US gal, 5.3 Imp gal)
Engine oil	0.02 L (0.02 US qt, 0.02 Imp qt)	0.24 L (0.25 US qt, 0.21 Imp qt)	0.28 L (0.30 US qt, 0.25 Imp qt)	0.48 L (0.51 US qt, 0.42 Imp qt)

**CAUTION:**

**Make sure to mix gasoline (petrol) and oil completely, otherwise your outboard motor may be damaged.**



EMU00231

Run the engine under load (in gear with a propeller installed) as follows.

- 1) First 10 minutes:  
Run the engine at the lowest possible-speed. A fast idle in neutral is best.
- 2) Next 50 minutes:  
Do not exceed half throttle (approximately 3,000 r/min). Vary engine speed occasionally. If you have an easy-planing boat, accelerate at full throttle onto plane, then immediately reduce the throttle to 3,000 r/min or less.
- 3) Second hour:  
Accelerate at full throttle onto plane, then reduce engine speed to three-quarter throttle (approximately 4,000 r/min). Vary engine speed occasionally. Run at full throttle for one minute, then allow about 10 minutes of operation at three-quarter throttle or less to let the engine cool.
- 4) Third through tenth hours:  
Avoid operating at full throttle for more than 5 minutes at a time. Let the engine cool between full-throttle runs. Vary engine speed occasionally. Avoid operating the engine at 2,000 r/min and below for more than 1 hour at a time.
- 5) After the first 10 hours:  
Operate the engine normally. Use straight gasoline (petrol) in the fuel tank; YAMAHA PRECISION BLEND SYSTEM provides proper lubrication for normal operation.



## STARTING ENGINE

### **⚠ WARNING**

- Before starting the engine, make sure that the boat is tightly moored and that you can steer clear of any obstructions. Be sure there are no swimmers in the water near you.
- When the air-vent screw is loosened, gasoline(petrol) vapor will be released. Gasoline(petrol) is highly flammable, and its vapors are flammable and explosive. Refrain from smoking, and keep away from open flames and sparks while loosening the air-vent screw.
- This product emits exhaust gases which contain carbon monoxide, a colorless, odorless gas which may cause brain damage or death when inhaled. Symptoms include nausea, dizziness, and drowsiness. Keep cockpit and cabin areas well ventilated. Avoid blocking exhaust outlets.

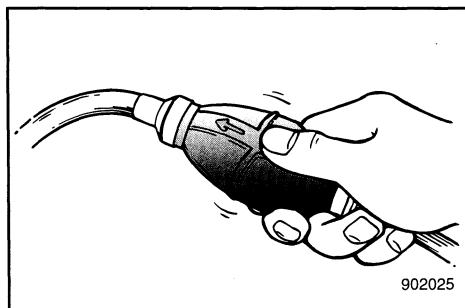
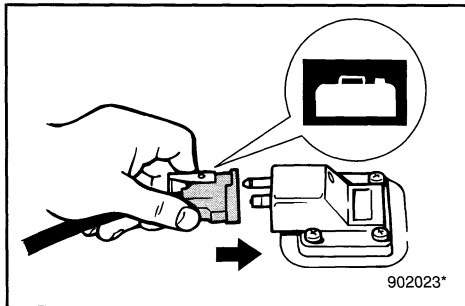

- 1) If the air vent screw is provided on the fuel tank cap, loosen it 2 or 3 turns.
- 2) If the fuel joints provided on the motor, firmly connect the fuel joint to the motor. Firmly connect the other joint to the fuel tank.

### **NOTE:**

During engine operation place the tank horizontally, or fuel could not be sucked.

- 3) Squeeze the primer bulb with the outlet end up until you feel it become firm.



E

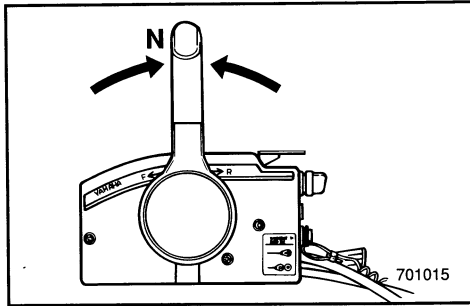

EMU00248

### PROCEDURE FOR REMOTE CONTROL MODEL

- 4) Place the remote control lever in the Neutral position.

**NOTE:** \_\_\_\_\_  
The start-in-gear protection device permits the engine to be started only when it is in Neutral.

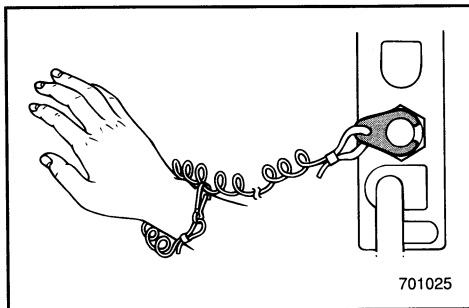
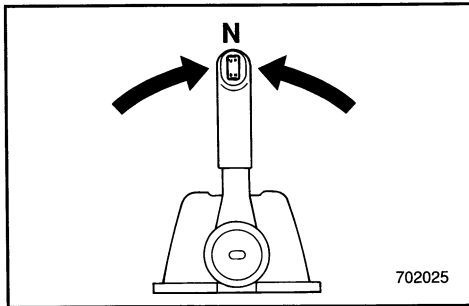

- 5) Attach the engine stop switch lanyard to a secure place on your clothing, or your arm or leg. Then, install the lock plate on the other end of the lanyard in the engine stop switch.

### **WARNING** \_\_\_\_\_

- Attach the engine stop switch lanyard to a secure place on your clothing, your arm or leg while operating.
- Do not attach the lanyard to clothing that could tear loose. Do not route the lanyard where it could become entangled, preventing it from functioning.
- Avoid accidentally pulling the lanyard during normal operation. Loss of engine power means the loss of most steering control. Also, without engine power, the boat could slow rapidly. This could cause people and objects in the boat to be thrown forward.

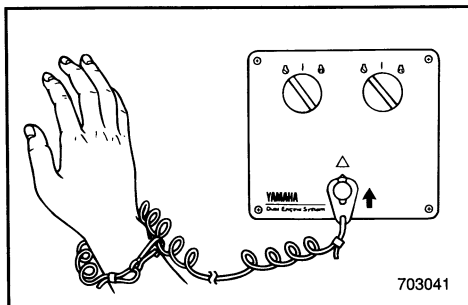



6) Turn the main switch to "ON".

**NOTE:**

In case of dual-engine operation, when the main switch is turned on, the buzzer operates for a few seconds and stops automatically. Should either of the dual engines stall, the buzzer operates.

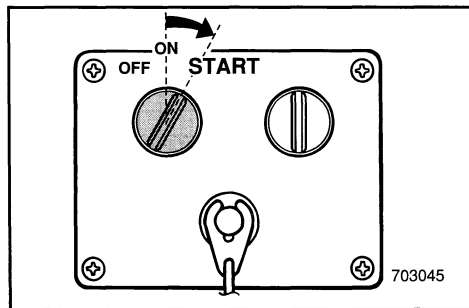
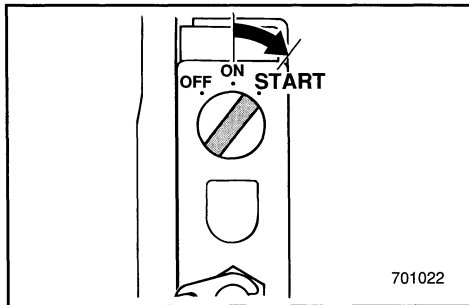

EMU00949

**Electric Start Model**

- 7) Turn the main switch to "START", and hold it for a maximum of 5 seconds.
- 8) Immediately after the engine starts, release the main switch to return it to "ON".

**CAUTION:**

- Do not turn the main switch to "START" when the engine is running.
- Do not keep the starter-motor turning for more than 5 seconds. The battery will rapidly become exhausted and it will be impossible for it to start the engine. If the engine does not start within 5 seconds, return the main switch to "ON", wait 10 seconds, and then crank the engine again.

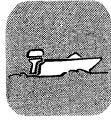

EMU00259

## WARMING UP ENGINE

- 1) Before beginning operation, allow the engine to warm up at idling speed for 3 minutes. (Failure to do this will shorten engine life.)
- 2) Check for a steady flow of water from the cooling-water pilot hole.

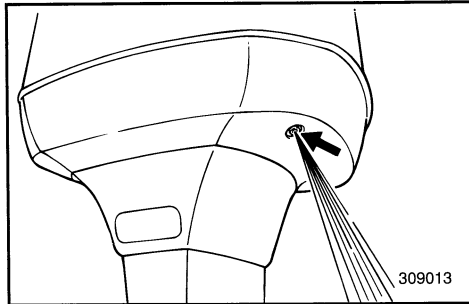

### CAUTION:

A continuous flow of water from the pilot hole shows that the water pump is pumping water through the cooling passages. If water is not flowing out of the pilot hole at all times while the engine is running, do not continue to run the engine. Overheating and serious damage could occur. Stop the engine and check to see if the water inlet on the lower casing is blocked. If the problem cannot be found and corrected, consult your Yamaha dealer.

### NOTE:

After the engine starts, warm-up operation is automatically controlled by Electronic Fuel Injection system. Automatic control is canceled if the throttle is opened more than halfway.



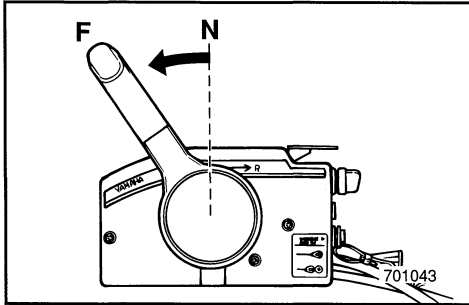
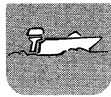

EMU00261

## SHIFTING

### **⚠WARNING**

Before shifting, make sure there are no swimmers or obstacles in the water near you.

### **CAUTION:**

To change the shifting position from forward to reverse or vice-versa, close the throttle first so that the engine idles (or runs at low speeds).

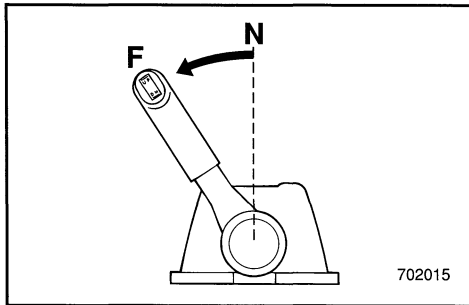

EMU00264

### **FORWARD**

Pull up the neutral interlock trigger (if equipped) and move the remote control lever quickly and firmly from Neutral to Forward.

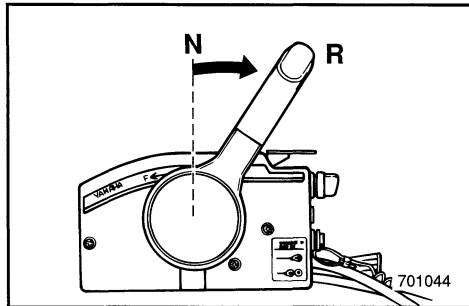

EMU00269

### **REVERSE**

### **⚠WARNING**

When operating in Reverse, go slowly. Do not open the throttle more than half. Otherwise, the boat may become unstable, which could result in loss of control and an accident.

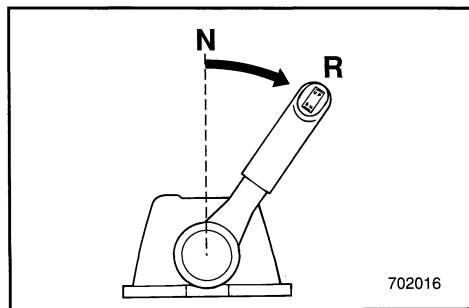

Pull up the neutral interlock trigger (if equipped) and move the remote control lever quickly and firmly from Neutral to Reverse.



EMU00273

## STOPPING ENGINE

Let it cool off for a few minutes at idle or low speed first. Stopping the engine immediately after operating at high speed is not recommended.

EMU00276

- 1) Turn the main switch to "OFF".
- 2) If the fuel joints are provided, disconnect the fuel line from the motor after stopping the engine.
- 3) Tighten the air vent screw on the fuel tank cap after stopping the engine, if it is equipped.
- 4) Remove the key if the boat will be left unattended.

**NOTE:** \_\_\_\_\_

The engine can also be stopped by pulling the lanyard and removing the lock plate from the engine stop lanyard switch (then turning the main switch to "OFF").

\_\_\_\_\_

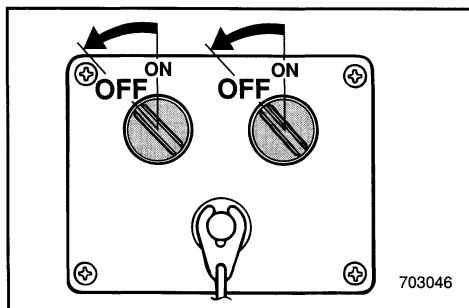
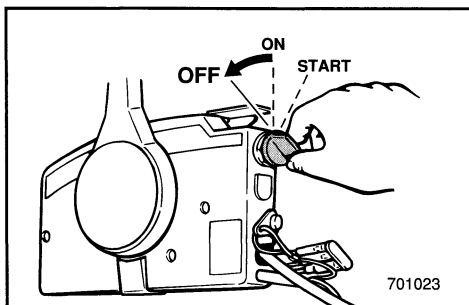



EMU00952

## TRIMMING OUTBOARD MOTOR

The trim angle of the outboard motor helps determine the position of the bow of the boat in the water. The correct trim angle will help improve performance and fuel economy while reducing strain on the engine. The correct trim angle depends upon the combination of boat, engine, and propeller. Correct trim is also affected by variables such as the load in the boat, sea conditions, and running speed.

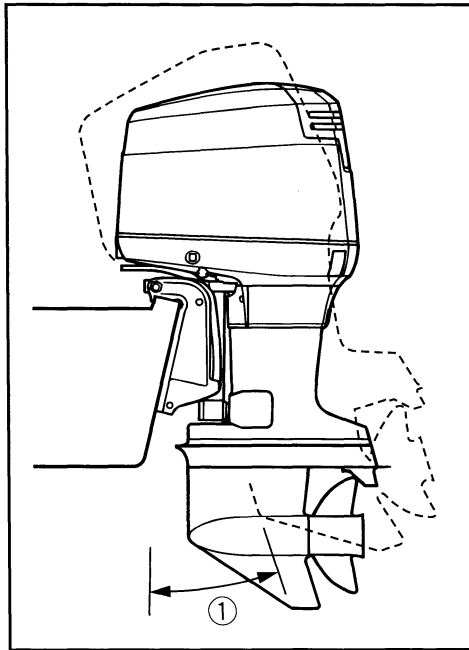

### **⚠ WARNING**

**Excessive trim for the operating conditions (either trim up or trim down) can cause boat instability and can make steering the boat more difficult. This increases the possibility of an accident. If the boat begins to feel unstable or is hard to steer, slow down and/or readjust the trim angle.**

① Trim operating angle

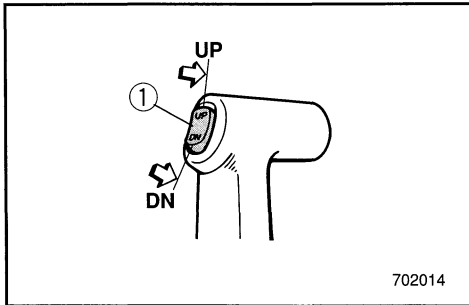
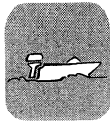

### ADJUSTING TRIM ANGLE

EMU00954

#### Power Trim/Tilt Model

#### **⚠WARNING**

Be sure all people are clear of the outboard motor when adjusting the trim/tilt angle, also be careful not to pinch any body parts between the drive unit and clamp bracket.

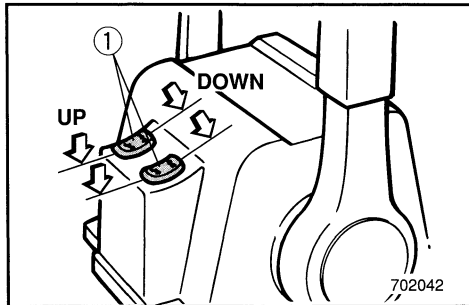

The outboard motor trim angle can be adjusted operating the power trim/tilt switch ①.

To raise the bow ("trim-out"), push the switch UP.

To lower the bow ("trim-in"), push the switch DN.

Make test runs with the trim set to different angles to find the position that works best for your boat and operating conditions.

#### **⚠WARNING**

Use caution when trying a trim position for the first time. Increase speed gradually and watch for any signs of instability or control problems. Improper trim angle can cause loss of control.

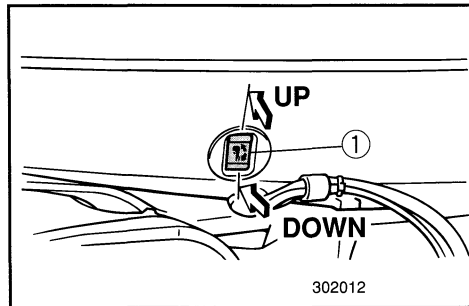

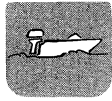

EMU00282

**Bow Up**

When the boat is on plane, a bow-up attitude result in less drag, greater stability and efficiency. This is generally when the keel line of the boat is up about 3 to 5 degrees. When trimmed out, the boat may have more tendency to steer to one side or the other. Compensate for this as you steer. The trim tab can also be adjusted to help offset this effect.

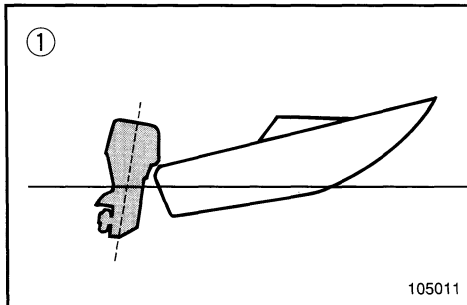

Too much trim-out puts the bow of the boat too high in the water. Performance and economy are decreased because the hull of the boat is pushing the water and there is more air drag.

Excessive trim-up can cause the propeller to ventilate, which reduces performance further. When trimmed-out too much, a boat may "porpoise" (hop in the water), which could throw the operator and passengers overboard.

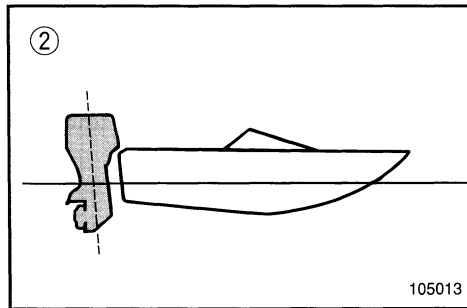

EMU00283

**Bow Down**

When the bow of the boat is down, it is easier to accelerate from a standing start onto plane.

Too much trim-in causes the boat to "plow" through the water, decreasing fuel economy and making in hard to increase speed.

Operating with excessive trim-in at higher speeds also makes the boat unstable. Resistance at the bow is greatly increased, heightening the danger of "bow steering" and making operation difficult and dangerous.

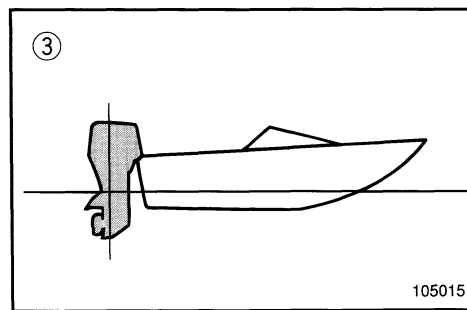

- ① Bow up
- ② Bow down
- ③ Optimum angle

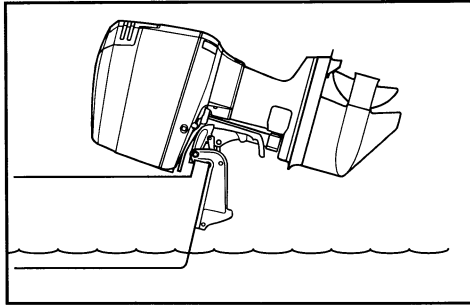

EMU00285

## TILTING UP/DOWN

If the engine will be stopped for some time, or if the boat is moored in shallows, the engine should be tilted up to protect the propeller and casing from damage by collision with obstructions, and also to reduce salt corrosion.

### **CAUTION:**

- Before tilting the motor, follow the procedures under "STOPPING ENGINE". Never tilt the motor while the engine is running. Severe damage from overheating can result.
- Do not tilt up the engine by pushing the steering handle as this could break the handle.

### **⚠ WARNING**

Be sure all people are clear of the outboard motor when adjusting the tilt angle, also be careful not to pinch any body parts between the drive unit and engine bracket.

### **⚠ WARNING**

Leaking fuel is a fire hazard. Disconnect the fuel line if the engine will be tilted for more than a few minutes. Otherwise, fuel may leak. (If the fuel connector is provided on the motor.)

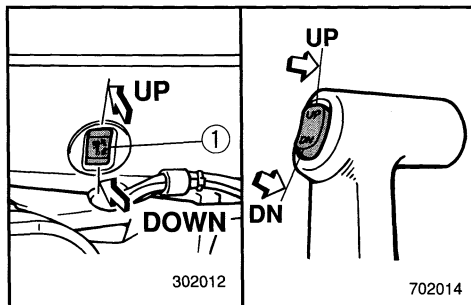

EMU00294

**PROCEDURE FOR TILTING UP**  
**Power trim/tilt model**

- 1) Remove the fuel-line connection from the motor.(If the fuel connector is provided on the motor.)
- 2) Push the power trim/tilt switch "UP" until the outboard has tilted up completely.

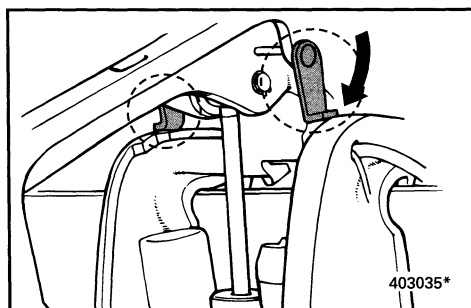
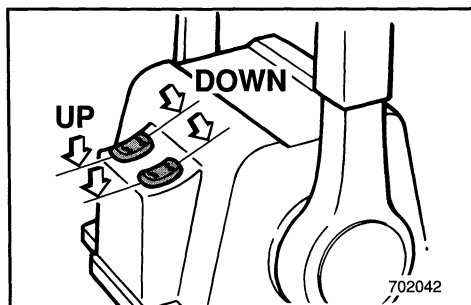

- 3) Turn the tilt-support lever toward you and support the engine.

**WARNING**

After tilting the engine, be sure to support it with the tilt-support lever. Otherwise, the engine could fall back down suddenly if oil in the power trim/tilt unit should lose pressure.

- 4) Once the engine is supported with the tilt-support lever, push the power trim/tilt switch DOWN to retract the trim rods.

**CAUTION:**

Be sure to retract the trim rods completely during mooring. This protects the rods from marine growths and corrosion which could damage the power trim/tilt mechanism.

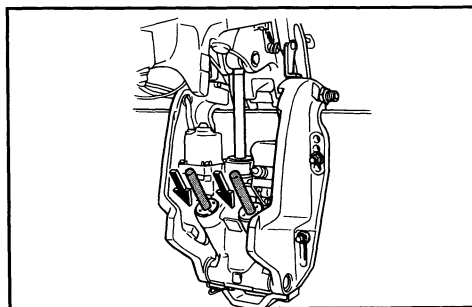

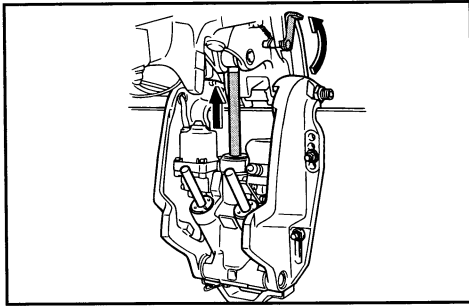
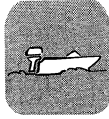

EMU00303

### PROCEDURE FOR TILTING DOWN

#### Power trim/tilt model

- 1) Push the power trim/tilt switch "UP" until the engine is supported by the tilt rod.
- 2) Release the tilt-support lever.
- 3) Push the power trim/tilt switch "DN" (Down) to lower the engine to the desired position.

EMU00316

### CRUISING IN OTHER CONDITIONS

#### CRUISING IN SALT WATER

After operating in salt water, wash out the cooling-water passages with fresh water to prevent them from becoming clogged-up with salt deposits.

**NOTE:** \_\_\_\_\_

Refer to cooling system flushing instructions in "TRANSPORTING AND STORING OUTBOARD MOTOR".

---

#### CRUISING IN TURBID WATER

It is strongly recommended that the optional chromium-plated water-pump kit be installed if the outboard is to be used in turbid (muddy) water conditions.



EMU00317

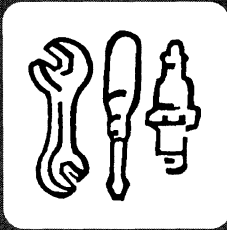

## Chapter 4

# MAINTENANCE

**SPECIFICATION DATA**.....4-1

### TRANSPORTING AND STORING

**OUTBOARD MOTOR** .....4-3

  Trailing outboard motor.....4-3

  Storing outboard motor .....4-4

**PERIODIC MAINTENANCE**.....4-8

  Replacement parts .....4-8

  Maintenance chart.....4-9

  Greasing .....4-10

  Cleaning and adjusting spark plug...4-11

  Checking fuel system.....4-13

  Cleaning fuel filter .....4-14

  Adjusting idling speed .....4-15

  Checking water trap under engine  
  oil tank .....4-16

  Replacing fuse .....4-17

  Checking wiring and connectors .....4-17

  Exhaust leakage.....4-17

  Water leakage .....4-17

  Checking power trim and tilt  
  system .....4-18

  Checking propeller .....4-19

  Changing gear oil .....4-21

  Inspecting and replacing anode(s) ...4-22

  Checking battery.....4-23

  Checking bolts and nuts .....4-26

  Motor exterior.....4-26

  Coating the boat bottom .....4-28



E

EMU00318

## SPECIFICATION DATA

	Model	Unit	SX150TRY
<b>DIMENSIONS</b>			
Overall Length		mm (in.)	823 (32.4)
Overall Width		mm (in.)	577 (22.7)
Overall Height	L/X	mm (in.)	1,615 (63.6) / 1,742 (68.6)
Transom height	L/X	mm (in.)	516 (20.3) / 642 (25.3)
Weight	L/X	kg (lb.)	206 (454) / 210 (463)
<b>PERFORMANCE</b>			
Full throttle operating range		r/min	4,500 ~ 5,500
Maximum output		kW (HP) @ r/min	110.3 (150.0) @ 5,000
Idling speed (Neutral)		r/min	700 ~ 760
<b>ENGINE</b>			
Type			2-stroke, 90°V6
Displacement		cm <sup>3</sup> (cu.in.)	2,596 (158.4)
Bore × stroke		mm (in.)	90.0 × 68.0 (3.54 × 2.68)
Ignition system			C.D.I system
Spark plug		NGK	BR7HS-10
Spark plug gap		mm (in.)	0.9 ~ 1.0 (0.035 ~ 0.039)
Control system			Remote control
Starting system			Electric start
Battery capacity		V-AH	12-70 (252) ~ 100 (360)
Minimum cold crank performance		Amps at -17.8°C (0°F)	380
Minimum reserve capacity		Minutes at 26.7°C (80°F)	124
Alternator output		V-A (W)	12-35
Starting carburation system			Electronic Fuel Injection
<b>DRIVE UNIT</b>			
Gear positions			Forward-Neutral-Reverse
Gear ratio			1.86 (26 / 14)
Trim/tilt system			Power trim & tilt
Propeller mark			M
<b>FUEL AND OIL</b>			
Recommended fuel		P.O.N.	Regular unleaded gasoline (Minimum 86)
Fuel tank capacity		l (US gal, Imp gal)	—
Recommended engine oil			YAMALUBE 2 STROKE OUTBOARD OIL or an equivalent TCW3 certified outboard oil YAMAHA PRECISION BLEND SYSTEM
Fuel/oil premix ratio		Fuel : Oil	0.9 (0.95, 0.79)
Engine oil capacity (engine oil tank)		l (US qt, Imp qt)	10.5 (11.1, 9.24), / 18.0 (19.1, 15.9)
Engine oil capacity (remote oil tank)		l (US qt, Imp qt)	
Recommended gear oil			Hypoid gear oil (SAE90)
Gear oil capacity		cm <sup>3</sup> (US oz, Imp oz)	980
<b>TIGHTENING TORQUE</b>			
Spark plug		Nm (m-Kg, ft-lb)	25 (2.5, 18)
Propeller nut		Nm (m-Kg, ft-lb)	55 (5.5, 40)



LX150TRY	SX200TRY	LX200TRY
823 (32.4) 577 (22.7) — / 1,742 (68.6) — / 642 (25.3) — / 212 (467.5)	823 (32.4) 577 (22.7) — / 1,742 (68.6) — / 642 (25.3) — / 210 (463)	823 (32.4) 577 (22.7) — / 1,742 (68.6) — / 642 (25.3) — / 212 (467.5)
4,500 ~ 5,500 110.3 (150.0) @ 5,000 700 ~ 760	4,500 ~ 5,500 147.1 (200.0) @ 5,000 700 ~ 760	4,500 ~ 5,500 147.1 (200.0) @ 5,000 700 ~ 760
2-stroke, 90°V6 2,596 (158.4) 90.0 × 68.0 (3.54 × 2.68) C.D.I system BR7HS-10 0.9 ~ 1.0 (0.035 ~ 0.039) Remote control Electric start 12-70 (252) ~ 100 (360) 380 124 12-35 Electronic Fuel Injection	2-stroke, 90°V6 2,596 (158.4) 90.0 × 68.0 (3.54 × 2.68) C.D.I system BR8HS-10 0.9 ~ 1.0 (0.035 ~ 0.039) Remote control Electric start 12-70 (252) ~ 100 (360) 380 124 12-35 Electronic Fuel Injection	2-stroke, 90°V6 2,596 (158.4) 90.0 × 68.0 (3.54 × 2.68) C.D.I system BR8HS-10 0.9 ~ 1.0 (0.035 ~ 0.039) Remote control Electric start 12-70 (252) ~ 100 (360) 380 124 12-35 Electronic Fuel Injection
Forward-Neutral-Reverse 1.86 (26 / 14) Power trim & tilt ML	Forward-Neutral-Reverse 1.86 (26 / 14) Power trim & tilt M	Forward-Neutral-Reverse 1.86 (26 / 14) Power trim & tilt ML
Regular unleaded gasoline (Minimum 86) — YAMALUBE 2 STROKE OUTBOARD OIL or an equivalent TCW3 certified outboard oil YAMAHA PRECISION BLEND SYSTEM 0.9 (0.95, 0.79) 10.5 (11.1, 9.24), / 18.0 (19.1, 15.9) Hypoid gear oil (SAE90) 870	Regular unleaded gasoline (Minimum 86) — YAMALUBE 2 STROKE OUTBOARD OIL or an equivalent TCW3 certified outboard oil YAMAHA PRECISION BLEND SYSTEM 0.9 (0.95, 0.79) 10.5 (11.1, 9.24), / 18.0 (19.1, 15.9) Hypoid gear oil (SAE90) 980	Regular unleaded gasoline (Minimum 86) — YAMALUBE 2 STROKE OUTBOARD OIL or an equivalent TCW3 certified outboard oil YAMAHA PRECISION BLEND SYSTEM 0.9 (0.95, 0.79) 10.5 (11.1, 9.24), / 18.0 (19.1, 15.9) Hypoid gear oil (SAE90) 870
25 (2.5, 18) 55 (5.5, 40)	25 (2.5, 18) 55 (5.5, 40)	25 (2.5, 18) 55 (5.5, 40)

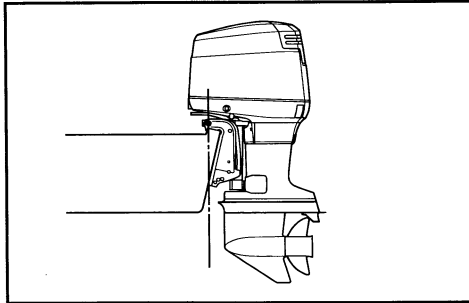

EMU00325

## TRANSPORTING AND STORING OUTBOARD MOTOR

EMU00326

### TRAILERING OUTBOARD MOTOR

The motor should be trailered and stored in the normal running position. If there is insufficient road clearance in this position, then trailer the motor in the tilt position using a motor support device such as a transom saver bar.

For further details, consult your Yamaha dealer.

#### **WARNING**

- **Never get under the lower unit while it is tilted, even if a motor support bar is used. Severe injury could occur if the outboard accidentally falls.**
- **USE CARE when transporting fuel tank, whether in a boat or car.**  
**DO NOT fill fuel container to maximum capacity. Gasoline will expand considerably as it warms up and can build up pressure in the fuel container. This can cause fuel leakage and a potential fire hazard.**

#### **CAUTION:**

**Do not use the tilt support lever/knob when trailering the boat. The outboard motor could shake loose from the tilt support and fall. If the motor can not be trailered in the down position, use an additional support device to secure it in the up position.**



EMU00332

**STORING OUTBOARD MOTOR**

When storing your Yamaha outboard for prolonged periods of time, (2 months or longer), several important procedures must be performed to prevent expensive damage. This is especially important for your Precision Blend equipped outboard due to the lean oil ratios used at idle prior to shutting the engine off for the season. It is advisable to have your outboard serviced by an authorized Yamaha dealer prior to storage. However, the following procedures can be performed by you, the owner, with a minimum of tools.

**CAUTION:**

**Do not use any chemical goods containing Silicon, Phosphorus or Lead. Otherwise, the oxygen sensor for Electronic Fuel Injection system could be damaged. For the detail, consult your Yamaha dealer to use chemical goods for storage.**

EMU00335

**Filling Fuel Tank**

Fill the fuel tank with fresh fuel and add one ounce of "Yamaha Fuel Conditioner and Stabilizer" (Part No. LUB-FUELC-12-00) to each gallon of fuel.

**NOTE:**

The use of "Yamaha Fuel Conditioner and Stabilizer" eliminates the need to drain the fuel system. Consult your Yamaha dealer or other qualified mechanic if the fuel system is to be drained instead.

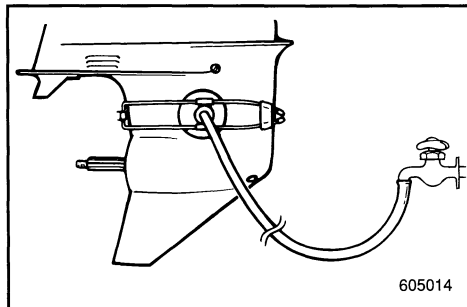
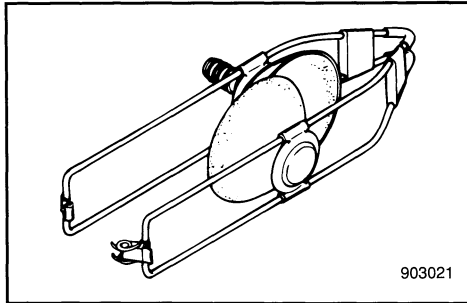

EMU00338\*

### Flushing Cooling System and Fogging Engine

Cooling system flushing is essential to prevent the cooling system from clogging up with salt, sand, or dirt. In addition, fogging of the engine is mandatory to prevent expensive engine damage due to rust. Perform the flushing and fogging at the same time.

#### **WARNING**

- Do not touch or remove electrical parts when starting or during operation.
- Keep hands, hair and clothes away from flywheel and other rotating parts while engine is running.

EMU00343

### Flushing with the Flushing Attachment

#### **CAUTION:**

Avoid running the outboard at high speed while on the flushing attachment, or overheating could occur.

- 1) Remove the top cowling and silencer cover. Remove the propeller.
- 2) Install a flushing attachment to the lower unit. (A flushing attachment is available from a Yamaha dealer).
- 3) Run the engine at a fast idle for 10~15 minutes supplying water.
- 4) Just prior to turning off the engine, quickly spray "Yamaha Stor-Rite Engine Fogging Oil" (Part No. LUB-STRRT-12-00) alternately into each intake manifold. When properly done, the engine will smoke excessively and almost stall.
- 5) Remove the flushing attachment and wipe off any excess water.
- 6) Install the silencer cover and top cowling. Install the propeller.



EMU00350

**Lubrication**

- 1) Remove the spark plug(s). Spray a "Yamaha Stor-Rite Engine Fogging Oil" into each cylinder for 10 seconds. Grease the spark plug threads and reinstall the spark plug(s) and torque to proper specification. (Refer to "CLEANING AND ADJUSTING SPARK PLUG".)
- 2) Turn the engine over with the stop lanyard disconnected to work the fogging oil into the piston rings.
- 3) Fill the oil tanks. This prevents the formation of condensation. For models with a remote tank, it may be necessary to manually override the control unit to completely fill the engine main tank. (Refer to Filling Oil section).
- 4) Change the gear-case oil. (Refer to "CHANGING GEAR OIL"). Inspect the oil for the presence of water which indicates a leaky seal. Seal replacement should be performed by an authorized Yamaha dealership prior to use.
- 5) Grease all grease fittings. (Refer to "GREASING")

EMU00352

**Cleaning and Anti-corrosion Measure**

- 1) Wash down the exterior of the outboard with fresh water and dry off completely.
- 2) Spray the engine's exterior with "Yamaha Silicone Protectant" (Part No. LUB-SILCNE-13-00).

**CAUTION:**

**Do not spray when the engine is running. Also, do not spray near the silencer and oxygen sensor cover or into the engine. Otherwise, the oxygen sensor for Electronic Fuel Injection system could be damaged.**

- 3) Wax the cowling with a non-abrasive wax such as "Yamaha Silicone Wax" (Part No. ACC-11000-15-02).



EMU00353

**Battery Care****⚠ WARNING**

**Battery electrolyte is poisonous and dangerous, causing severe burns, etc. It contains sulfuric acid. Avoid contact with skin, eyes, or clothing.**

**Antidote:**

**EXTERNAL; Flush with water.**

**INTERNAL; Drink large quantities of water or milk. Follow with milk of magnesia, beaten egg, or vegetable oil. Call physician immediately.**

**EYES; Flush with water for 15 minutes and get prompt medical attention.**

**Batteries produce explosive gases: Keep sparks, flame, cigarettes, etc. away. Ventilate when charging or using in a closed space. Always wear eye protection when working near batteries.**

**KEEP OUT OF REACH OF CHILDREN.**

Batteries vary among manufacturers. Therefore the following procedures may not always apply. Consult your battery manufacturer's instructions.

- 1) Disconnect and remove the battery from the boat. Always disconnect the black negative lead first to prevent the risk of shorting.
- 2) Clean the battery casing and terminals. Fill each cell to the upper level with distilled water.
- 3) Store the battery on a level surface in a cool, dry, well-ventilated place out of direct sunlight.
- 4) Once a month, check the specific gravity of the electrolyte and recharge as required to prolong battery life.

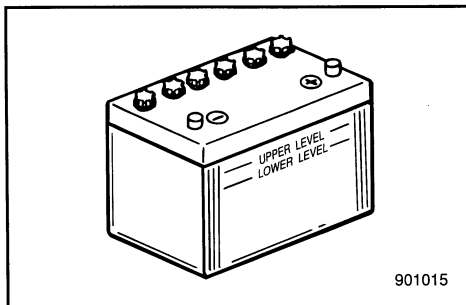





EMK32110

## PERIODIC MAINTENANCE

### **⚠ WARNING**

Be sure to turn off the engine when you perform maintenance unless otherwise specified. If the owner is not familiar with machine servicing, this work should be done by a Yamaha dealer or other qualified mechanic.

A service manual is available for purchase through a Yamaha dealer for owners who have the mechanical skills, tools, and other equipment necessary to perform maintenance not covered by this owner's manual.

EMU00356

### **REPLACEMENT PARTS**

If replacement parts are necessary, use only genuine Yamaha parts or equivalents of the same type and of equivalent strength and materials. Any part of inferior quality may malfunction, and the resulting loss of control could endanger the operator and passengers.

Yamaha genuine parts and accessories are available from a Yamaha dealer.



EMU00362

### MAINTENANCE CHART

Frequency of maintenance operations may be adjusted according to the operating conditions, but the following table gives general guidelines.

The mark (●) indicates the check-ups which you may carry out yourself.

The mark (○) indicates work to be carried out by your Yamaha dealer.

Item		Interval	Initial		Every		Refer page
			10 hours (1 months)	50 hours (3 months)	100 hours (6 months)	200 hours (1 year)	
Spark plug(s)	Cleaning/Adjustment/Replacement	●	●	●			4-11
Greasing points	Greasing			●			4-10
Gear oil	Change	●		●			4-21
Fuel system	Inspection	●	●	●			4-12
Fuel filter (Water separator)	Cleaning/Inspection	●	●	●			4-14
Fuel tank	Cleaning				●		—
Idling speed	Inspection/Adjustment	●		●			4-15
Anode(s)	Inspection/Replacement		●/○	●/○			4-22
Outboard motor exterior	Inspection	●	●	●			4-26
Cooling water passage*1	Cleaning		●	●			4-27
Propeller/Cotter pin	Inspection/Replacement	●	●	●			4-19
Battery	Inspection/Charge	● (every 1 month)					4-23
Throttle pick-up timing	Inspection/Adjustment				○		—
Bolts/Nuts	Retightening	●	●	●			4-26
Oil tank water drain	Cleaning	●	●	●			4-16
Oil pump	Inspection/Adjustment	○					—
Power trim/tilt unit	Inspection				●		4-18
Power trim/tilt operation	Inspection	●	●	●			4-18
Exhaust leakage	Inspection	●	●	●			4-17
Water leakage	Inspection	●	●	●			4-17
Cowling clamp	Inspection				●		—
Throttle link	Inspection/Adjustment				○		—
Throttle sensor	Inspection/Adjustment				○		—
Wiring/Connector(s)	Inspection/Reconnect	●	●	●			4-17

\*1. When operating in salt water, turbid or muddy water, the engine should be flushed with clean water after each use.



E

EMU00366

## GREASING

Yamaha marine grease  
(Water resistant grease)

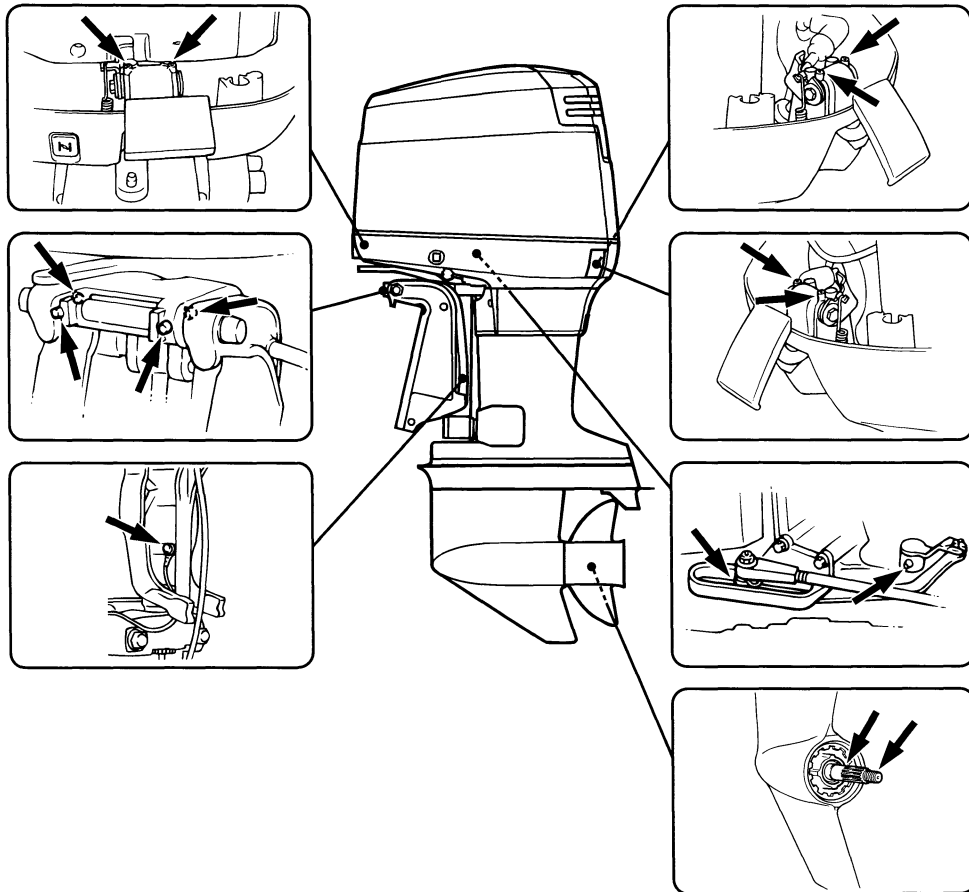



MU00368

## CLEANING AND ADJUSTING SPARK PLUG

### **⚠ WARNING**

**When removing or installing a spark plug, be careful not to damage the insulator. A damaged insulator could allow external sparks, which could lead to explosion or fire.**

The spark plug is an important engine component and is easy to inspect. The condition of the spark plug can indicate something about the condition of the engine. For example, if the center electrode porcelain is very white, this could indicate an intake air leak or carburetion problem in that cylinder. Do not attempt to diagnose any problems yourself. Instead, take the outboard motor to a Yamaha dealer. You should periodically remove and inspect the spark plug because heat and deposits will cause the spark plug to slowly break down and erode. If electrode erosion becomes excessive, or if carbon and other deposits are excessive, you should replace the spark plug with another of the correct type.

Standard spark plug:  
Refer to "SPECIFICATIONS", page 4-1.

Before fitting the spark plug, measure the electrode gap with a wire thickness gauge; adjust the gap to specification if necessary.



Spark plug gap:  
Refer to "SPECIFICATIONS", page 4-1.

When fitting the plug, always clean the gasket surface and use a new gasket. Wipe off any dirt from the threads and screw in the spark plug to the correct torque.

Spark plug torque:  
Refer to "SPECIFICATIONS", page 4-1.

**NOTE:**  
If a torque-wrench is not available when you are fitting a spark plug, a good estimate of the correct torque is 1/4 to 1/2 a turn past finger-tight. Have the spark plug adjusted to the correct torque as soon as possible with a torque-wrench.

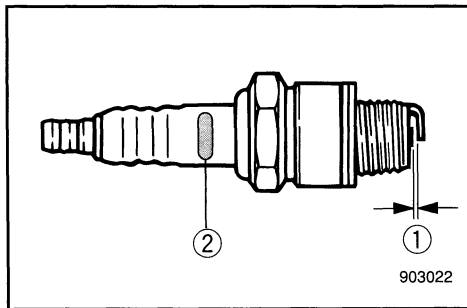

Initial of spark plug I.D. mark	Plug wrench size
B	21 mm (13/16 in.)
C	16 mm (5/8 in.)
D	18.3 mm (23/32 in.)

- ① Spark plug gap
- ② Spark plug I.D. mark (NGK)



E

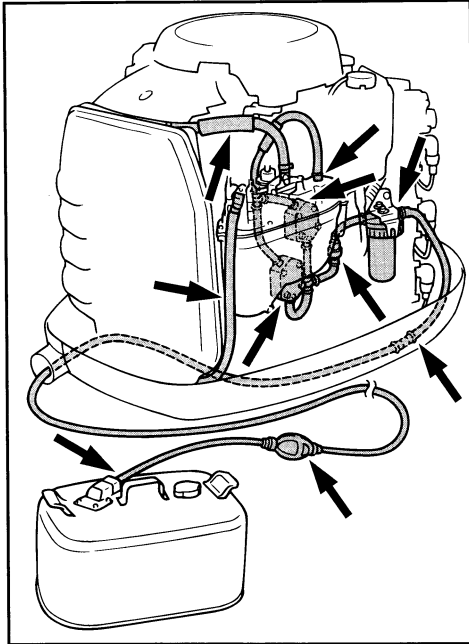

EMU00369

## CHECKING FUEL SYSTEM

### **⚠ WARNING**

Gasoline (petrol) and its vapors are highly flammable and explosive. Keep away from sparks, cigarettes, flames or other sources of ignition.

Check the fuel line for leaks, cracks, or malfunctions. If any problem is found, it should be repaired immediately by Yamaha dealer or other qualified mechanic.

### Checking points

- Fuel system parts leakage.
- Fuel hose joint leakage.
- Fuel hose cracks or other damage.
- Fuel connector leakage.

### **⚠ WARNING**

Leaking fuel can result in fire or explosion.

- Check for fuel leakage regularly.
- If any fuel leakage is found, the fuel system must be repaired by a qualified mechanic. Improper repairs can make the outboard unsafe to operate.



EMU00370

### INSPECTING FUEL FILTER

#### **⚠WARNING**

Gasoline (petrol) is highly flammable, and its vapors are flammable and explosive.

- If you have any question about properly doing this procedure, consult your Yamaha dealer.
- Do not perform this procedure on a hot or running engine. Allow the engine to cool.
- There will be fuel in the fuel filter. Keep away from sparks, cigarettes, flames or other sources of ignition.
- This procedure will allow some fuel to spill. Catch fuel in a rag. Wipe up any spilled fuel immediately.
- The fuel filter must be reassembled carefully with O-ring, filter cup, and hoses in place. Improper assembly or replacement can result in a fuel leak, which could result in a fire or explosion hazard.

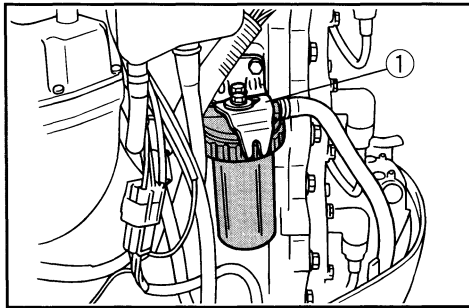

EMU00979

- 1) Loosen and remove the locking tab bolt and tab ①. Slightly loosen the filter cup ring nut ②.
- 2) Remove the filter cup ③, catching any spilled fuel in a rag.
- 3) Remove the filter element ④, and wash it in solvent.

Allow it to dry. Inspect the filter element and O-ring ⑤ to make sure they are in good condition. Replace them if necessary.

- 4) Reinstall the filter element in the cup. Make sure the O-ring is in position in the cup. Insert the cup and O-ring into the filter housing ⑥. Screw the ring nut onto the filter housing until the ring is lightly seated.

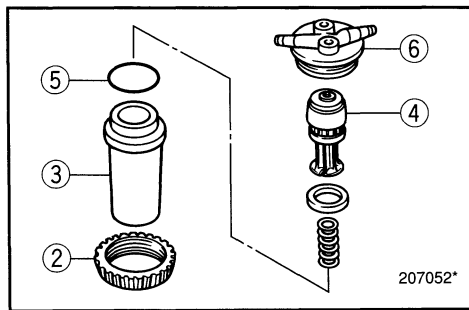



E

- 5) Tighten the ring nut approximately an additional 1/4 turn until ring nut is tight. Align one of the four larger ring nut tabs into the slot of the locking tab. Install the locking tab bolt and tighten.
- 6) Run the engine and check the filter and lines for leaks.

**NOTE:** \_\_\_\_\_

If any water is in the fuel, the red ring in the fuel filter unit will float. If so, remove the cup and drain the water.

---

EMU00991

### ADJUSTING IDLING SPEED

**⚠ WARNING** \_\_\_\_\_

- Do not touch or remove electrical parts when starting or during operation.
  - Keep hands, hair and clothes away from flywheel and other rotating parts while engine is running.
- 

**CAUTION:** \_\_\_\_\_

This procedure must be performed while the outboard motor is in the water. A flushing attachment or test tank can be used.

---





A diagnostic tachometer should be used for this procedure.

- 1) Start the engine and allow it to warm up fully in Neutral until it is running smoothly. If the outboard is mounted on a boat, be sure the boat is tightly moored.
- 2) Adjust the throttle stop-screw ① to set the idling speed to specification (see "SPECIFICATIONS" on page 4-1) by turning the stop-screw clockwise to increase the idling speed, and turning it counterclockwise to decrease the idling speed.

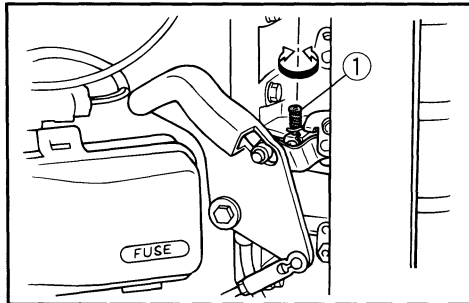

**NOTE:**

Correct idling-speed adjustment is only possible if the engine is fully warmed-up. If not warmed up fully, the speed setting will tend to be too high. If you have difficulty obtaining the specified idle, consult a Yamaha dealer or other qualified mechanic.

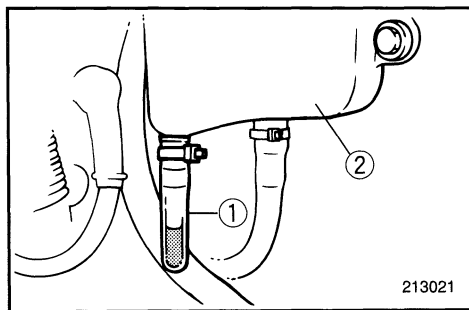

EMU00377

**CHECKING WATER IN ENGINE OIL TANK**

There is a trap at the bottom of the engine oil tank. If water or foreign matter is visible in this trap, consult a Yamaha dealer.

- ① Trap
- ② Engine oil tank

213021



E

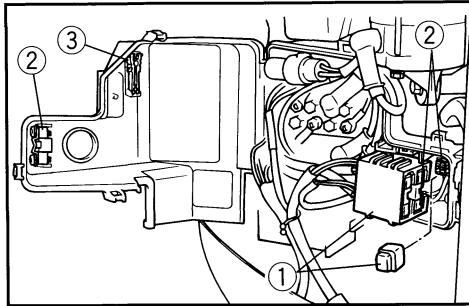

EMU00382\*

### REPLACING FUSE

If the fuse has blown for Electric start model, open the fuse box and replace the fuse with a new one of the proper amperage.

#### **⚠ WARNING**

**Be sure to use the specified fuse. A wrong fuse or a piece of wire may allow excessive current flow. This could cause electrical system damage and a fire hazard.**

#### **NOTE:**

If the new fuse blows again immediately, consult a Yamaha dealer.

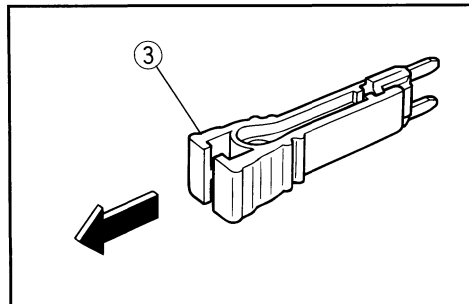

- ① Fuse box
- ② Fuse (30A, 80A × 2)
- ③ Fuse puller

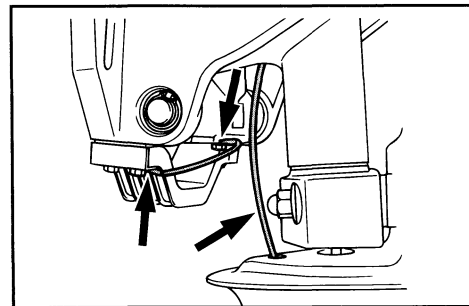

EMU00383

### CHECKING WIRING AND CONNECTORS

- 1) Check that each grounding wire is properly secured.
- 2) Check that each connector is engaged securely.

EMU00384

### EXHAUST LEAKAGE

Start the engine and check that no exhaust leaks from the joints between the exhaust cover, cylinder head and crank case.

EMU00385

### WATER LEAKAGE

Start the engine and check that no water leaks from the joints between the exhaust cover, cylinder head and crank case.



EMU00993

## CHECKING POWER TRIM AND TILT SYSTEM

### **⚠WARNING**

- Never get under the lower unit while it is tilted, even when the tilt-support lever is locked. Severe injury could occur if the outboard accidentally falls.
- Make sure no one is under the outboard before performing this test.

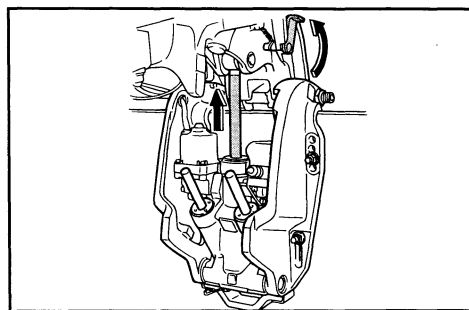
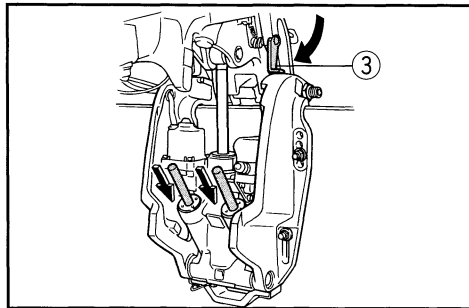
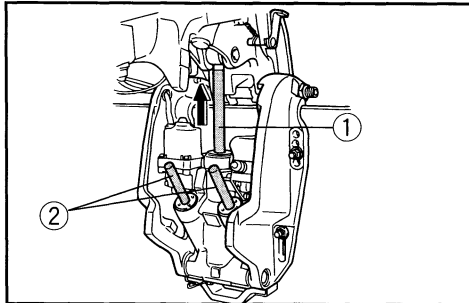

- 1) Check the power trim and tilt unit for any sign of oil leaks.
- 2) Operate each of the power trim and tilt switches on remote control and engine bottom cowling (If equipped) to check that all switches work.
- 3) Tilt up the motor and check that the tilt rod ① and trim rods ② are pushed out completely.
- 4) Use the tilt support lever ③ to lock the motor in the UP position. Operate the tilt down switch briefly so the motor is supported the tilt support lever.
- 5) Check that the tilt rod and trim rods are free of corrosion or other flaws.
- 6) Activate the tilt-down switch until the trim rods have gone completely into the cylinders.
- 7) Activate the trim-up switch until the tilt rod is fully extended. Unlock the tilt support lever.
- 8) Operate the motor to tilt down. Check that the tilt rod and trim rods operate smoothly.

### **NOTE:**

If any operation is abnormal, consult a Yamaha dealer.

Recommended fluid;  
Yamaha power trim & tilt fluid or  
ATF (DEXRON-II).

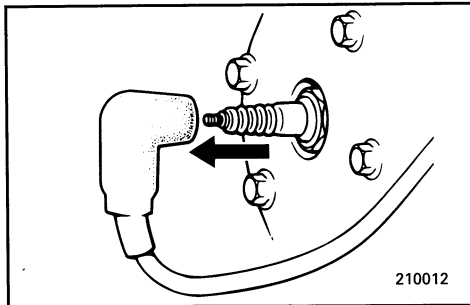

210012

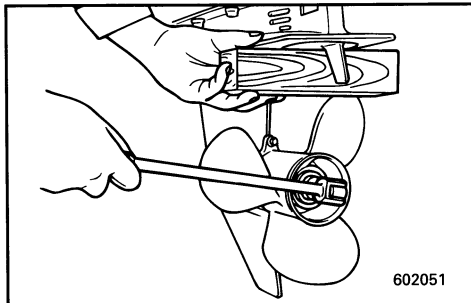

602051

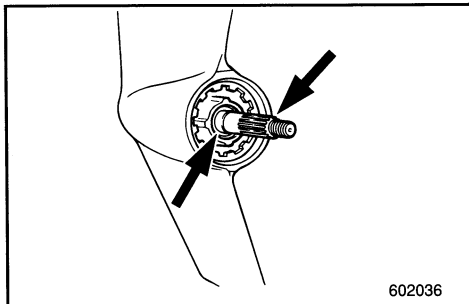

602036

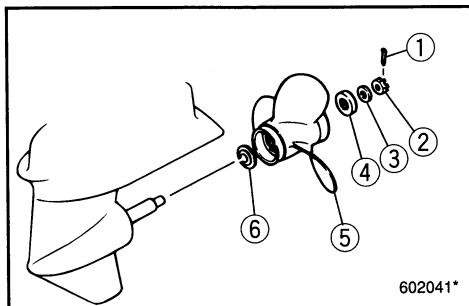

602041\*

EMU00388

## CHECKING PROPELLER

### ⚠ WARNING

You could be seriously injured if the engine accidentally starts while you are near the propeller.

- Before inspecting, removing or installing the propeller, remove the spark plug caps from the spark plugs. Also, put the shift control in Neutral, put the main switch in the "OFF" position and remove the key, and remove the lanyard from the engine stop switch. Turn off the battery cut-off switch if your boat has one.
- Do not use your hand to hold the propeller when loosening or tightening the propeller nut. Put a wood block between the cavitation plate and the propeller to prevent the propeller from turning.

EMU00390

### Propeller Checking Point

- Check each of the propeller blades for wear, erosion from cavitation or ventilation, or other damage.
- Check the splines for wear and damage.
- Check for fish line winding around the propeller shaft.
- Check the propeller shaft oil seal for damage.

EMU00976

### Removing the Propeller

- 1) Straighten the cotter-pin ① and pull it out using a pair of pliers.
- 2) Remove the propeller nut ②, washer ③ and spacer ④.
- 3) Remove the propeller ⑤ and thrust washer ⑥.



EMU00397

**Installing the Propeller****CAUTION:**

- Be sure to install the thrust washer before installing propeller, otherwise, lower case and propeller boss may be damaged.
- Be sure to use a new cotter pin and bend the ends over securely. Otherwise, the propeller could come off during operation and be lost.

- 1) Apply Yamaha Marine grease or Corrosion resistant grease to the propeller-shaft.
- 2) Install the thrust washer and propeller on the propeller-shaft.
- 3) Install the spacer and washer. Tighten the propeller nut to the specified torque.

Tightening torque:  
Refer to "SPECIFICATIONS" page 4-1.

- 4) Align the propeller nut with the propeller shaft hole. Insert a new cotter pin in the hole and bend the cotter pin ends.

**NOTE:**

If the propeller nut does not align with the propeller shaft hole after tightening to the specified torque, then tighten the nut further to align it with the hole.

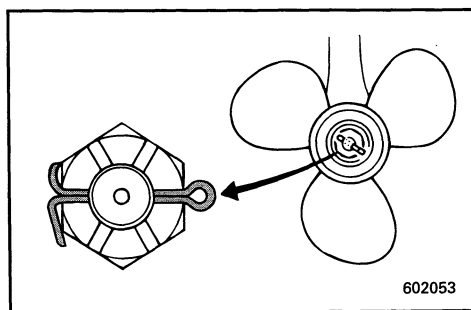



EMU00905

## CHANGING GEAR OIL

### **⚠WARNING**

- Be sure the outboard is securely fastened to the transom or a stable stand. You could be severely injured if the outboard falls on you.
- Never get under the lower unit while it is tilted, even when the tilt-support lever is locked. Severe injury could occur if the outboard accidentally falls.

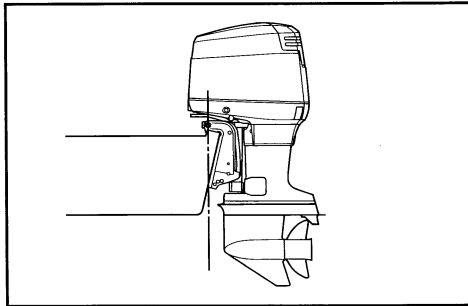

- 1) Put the outboard in a vertical position (not tilted).
- 2) Place a suitable container under the gear-case.
- 3) Remove the oil drain plug ①.

### **NOTE:**

The oil drain plug is magnetic. Remove all metal particles from the plug before reinstalling it.

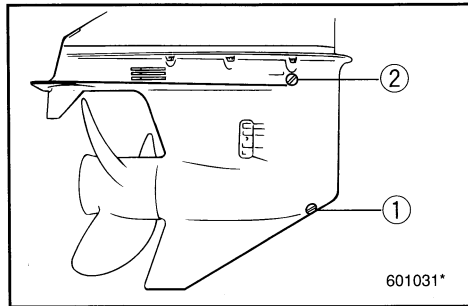

- 4) Remove the oil level plug ② to allow the oil to drain completely.

### **CAUTION:**

Inspect the used oil after it has been drained. If the oil is milky, water is getting into the gear-case which can cause gear damage. Consult a Yamaha dealer for repair of the lower unit seals.

### **NOTE:**

For disposal of used oil consult your Yamaha dealer.

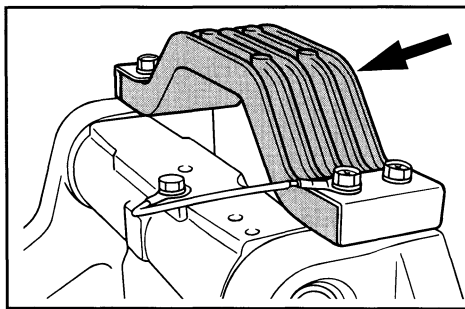

**Do not paint the anode(s), for this would render it ineffective.**

**CAUTION:**

For the inspection and replacement of the anode(s), consult a Yamaha dealer. Check the anode(s) periodically. Remove the scales from surfaces of the anode(s). Yamaha outboard motor is protected from corrosion by a sacrificial anode(s).

**INSPECTING AND REPLACING ANODE(S)**

EMU00831

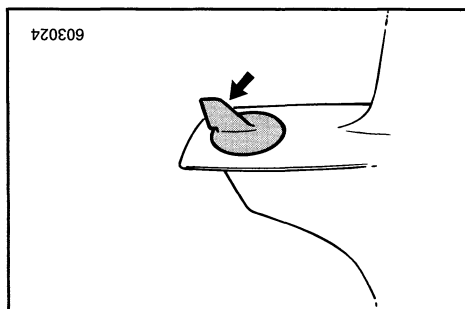

- 5) With the outboard motor in a vertical position, using a flexible or pressurized filling device, inject the gear oil into the oil drain plug hole.
- Gear oil grade/capacity:  
Refer to SPECIFICATIONS on page 4-1.
- 6) When the oil begins to flow out of the oil level plug hole, insert and tighten the oil level plug.
  - 7) Insert and tighten the oil drain plug.

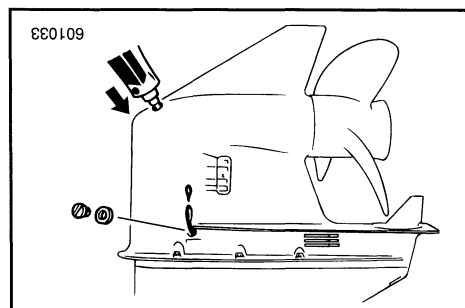

**E**



EMU00404

## CHECKING BATTERY (for Electric start model)

### **⚠WARNING**

Battery electrolytic fluid is dangerous; it contains sulfuric acid and therefore is poisonous and highly caustic.

Always follow these preventive measures:

- Avoid bodily contact with electrolytic fluid as it can cause severe burns or permanent eye injury.
- Wear protective eye gear when handling or working near batteries.

Antidote (EXTERNAL):

- SKIN - Flush with water.
- EYES - Flush with water for 15 minutes and get immediate medical attention.

Antidote (INTERNAL):

- Drink large quantities of water or milk followed by milk of magnesia, beaten egg, or vegetable oil. Get immediate medical attention.

Batteries also generate explosive hydrogen gas; therefore, you should always follow these preventive measures:

- Charge batteries in a well-ventilated area.
- Keep batteries away from fire, sparks, or open flames (e.g., welding equipment, lighted cigarettes, etc.).
- DO NOT SMOKE when charging or handling batteries.
- KEEP BATTERIES AND ELECTROLYTIC FLUID OUT OF REACH OF CHILDREN.



**CAUTION:**

- A poorly maintained battery will quickly deteriorate.
- Ordinary tap-water contains minerals harmful to a battery, and should not be used for topping-up.

- 1) Check the electrolyte level at least once a month. Fill to the manufacturer's recommended level when necessary. Top up only with distilled water (or pure de-ionized water suitable to use in batteries).
- 2) Keep the battery always in a good state of charge. Installing a voltmeter will help you monitor your battery. If you will not use the boat for a month or more, remove the battery from the boat and store it in a cool, dark place. Completely recharge the battery before using it.
- 3) If the battery will be stored for longer than a month, check the specific gravity of the fluid at least once a month and recharge the battery when it is low.

EMU00406

**Connecting the Battery****⚠ WARNING**

Mount the battery holder securely in a dry, well-ventilated, vibration-free location in the boat. Install the fully charged battery in the holder.

Connect the RED lead to the POSITIVE (+) terminal first. Then connect the BLACK lead to the NEGATIVE (-) terminal.

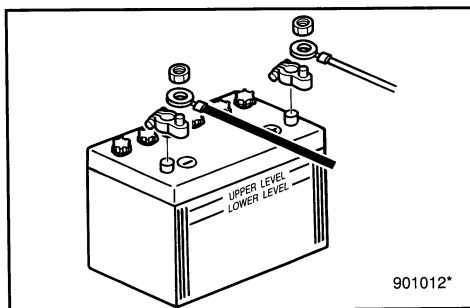



E

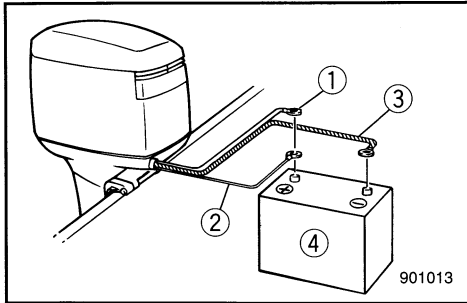

• **Using a single battery**

Connect both red cables ① and ② to the (+) terminal.

**⚠WARNING**

**Do not leave cable ② unconnected. If it accidentally contacts the NEGATIVE (-) terminal of the battery, there will be a short circuit. Electrical system damage and a fire could result.**

- ① Large red lead for starting battery
- ② Small red lead for accessory battery charging
- ③ Large black lead
- ④ Battery

• **Using an accessory battery**

Use a connecting cable between the (-) terminals of the starting battery and accessory battery. See the illustrations of the wiring connections. This cable must be made from wire equivalent to the starting battery cable ③.

**⚠WARNING**

**Use of smaller wire could lead to a fire.**

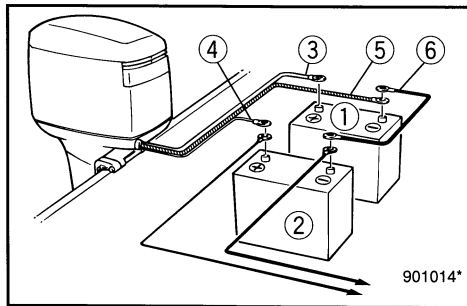

- ① Battery for starting
- ② Battery for accessories
- ③ Large red lead for starting battery
- ④ Small red lead for accessory battery charging
- ⑤ Large black lead
- ⑥ Negative connecting cable

**NOTE:**

If a battery selector switch is desired, consult your YAMAHA dealer about correct wiring.



EMU00407

### Disconnecting the Battery

Disconnect the BLACK lead from the NEGATIVE (-) terminal first. Then disconnect the RED lead from the POSITIVE (+) terminal.

#### **CAUTION:**

- Make sure the main switch (on applicable models) is "OFF" before working on the battery.
- Reversal of the battery leads will damage the rectifier.
- Connect the RED lead first when installing the battery and disconnect the RED lead last when removing it. Otherwise, the electrical system can be damaged.
- The electrical contacts of the battery and cables must be clean and properly connected, or the battery will not start the engine.

EMU00408

### CHECKING BOLTS AND NUTS

- 1) Check that bolts securing the cylinder head and engine and the nut securing the flywheel are tightened with their specified tightening torque.
- 2) Check the tightening torque of other bolts and nuts.

EMU00409

### MOTOR EXTERIOR

EMU00410

#### Cleaning the Outboard Motor

After use, wash the exterior of the outboard with fresh water.

Flush the cooling system with fresh water.

#### **NOTE:**

Refer to Flushing Cooling System instructions in "TRANSPORTING AND STORING OUTBOARD MOTOR".



EMU01096\*

### **Cleaning Cooling-water Passages** **Flushing device equipped model**

Perform this procedure right after operation for the most thorough flushing.

- 1) After shutting off the engine, unscrew the garden-hose connector ② from the fitting ① on the bottom cowling.
- 2) Screw the garden-hose connector ② onto a garden hose ③ which is connected to a fresh-water supply.
- 3) With the engine off, turn on the water tap and let the water flush through the cooling passages for about 15 minutes. Turn off the water and disconnect the garden hose ③.
- 4) When flushing is complete, reinstall the garden-hose connector ② on the fitting ① on the bottom cowling. Tighten the connector securely.

#### **CAUTION:**

**Do not leave the garden-hose connector loose on the bottom cowling fitting or let the hose hang free during normal operation. Water will leak out of the connector instead of cooling the engine, which can cause serious overheating. Be sure the connector is tightened securely on the fitting after flushing the engine.**

#### **NOTE:**

- When flushing the engine with the boat in the water, tilting up the engine until it is completely out of the water will achieve better results.
- Refer to cooling system flushing instructions in "TRANSPORTING AND STORING OUTBOARD MOTOR".

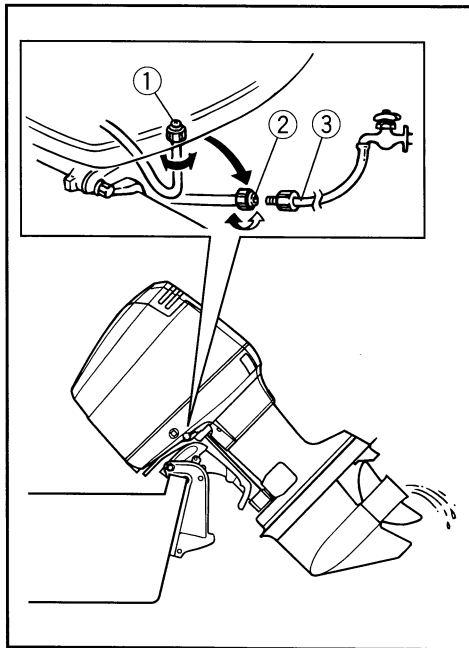



E

EMU00412

### Checking Painted Surface of Motor

Check the motor for scratches, nicks, or flaking paint. Areas with damaged paint are more likely to corrode. If necessary, clean and paint the areas. A touch-up paint is available from a Yamaha dealer.

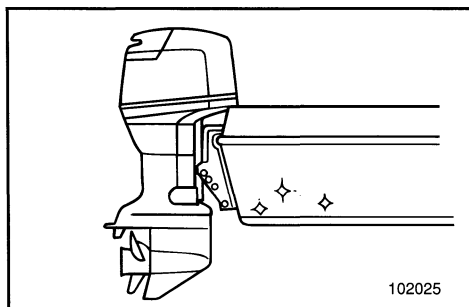

EMU00413

### COATING THE BOAT BOTTOM

A clean hull improves boat performance. The boat bottom should be kept as clean of marine growths as possible. If necessary, the boat bottom can be coated with an anti-fouling paint approved for your area to inhibit marine growth.

Do not use anti-fouling paint which includes copper or graphite. These paints can cause more rapid engine corrosion.



E

---

**- MEMO -**

EMU00414

# Chapter 5 TROUBLE RECOVERY



**TROUBLESHOOTING** .....5-1

**TEMPORARY ACTION IN  
EMERGENCY** .....5-5

Impact damage .....5-5

**RUNNING SINGLE ENGINE** .....5-5

Power trim/tilt will not operate .....5-6

Starter will not operate .....5-7

Engine fails to operate .....5-9

Low oil level warning works .....5-11

Treatment of submerged motor .....5-13



### TROUBLESHOOTING

Trouble	Possible Cause	Remedy
A. Starter will not operate	<ol style="list-style-type: none"><li>1. Battery capacity weak or low</li><li>2. Battery connections loose or corroded</li><li>3. Fuse for electric start circuit blown</li><li>4. Starter components faulty</li><li>5. Engine stop switch lanyard not attached</li><li>6. Shift lever is gear-in position</li></ol>	<ol style="list-style-type: none"><li>1. Check battery condition. Use battery of recommended capacity.</li><li>2. Tighten battery cables and clean battery terminals.</li><li>3. Check for cause of electric overload and repair. Replace fuse with one of correct amperage.</li><li>4. Have Yamaha dealer service.</li><li>5. Attach lanyard.</li><li>6. Position to neutral.</li></ol>
B. Engine will not start (Starter operates)	<ol style="list-style-type: none"><li>1. Fuel tank empty</li><li>2. Fuel contaminated or stale</li><li>3. Fuel filter clogged</li><li>4. Starting procedure is wrong</li><li>5. Fuel pump malfunctions</li><li>6. Spark plug(s) fouled or wrong type</li><li>7. Spark plug cap(s) fitted incorrectly</li><li>8. Poor connections or damaged ignition wiring</li><li>9. Ignition parts faulty</li><li>10. Engine stop switch lanyard not attached</li><li>11. Shift lever is gear-in position</li><li>12. Engine inner parts damaged</li></ol>	<ol style="list-style-type: none"><li>1. Fill tank with clean, fresh fuel.</li><li>2. Fill tank with clean, fresh fuel.</li><li>3. Clean or replace it.</li><li>4. Read "STARTING ENGINE" section.</li><li>5. Have Yamaha dealer service.</li><li>6. Inspect spark plug(s). Clean or replace with recommended type.</li><li>7. Check and re-fit cap(s).</li><li>8. Check wires for wear or breaks. Tighten all loose connections. Replace worn or broken wires.</li><li>9. Have Yamaha dealer service.</li><li>10. Attach lanyard.</li><li>11. Position to neutral.</li><li>12. Have Yamaha dealer service.</li></ol>





Trouble	Possible Cause	Remedy
C. Engine idles irregularly or stalls	<ol style="list-style-type: none"><li>1. Spark plug(s) fouled or wrong type</li><li>2. Fuel system obstructed</li> <li>3. Fuel contaminated or stale</li><li>4. Fuel filter clogged</li><li>5. Failed ignition parts</li><li>6. Warning system activated</li><li>7. Spark plug gap incorrect</li><li>8. Poor connections or damaged ignition wiring</li><li>9. Fuel filter clogged.</li><li>10. Specified engine oil not used</li><li>11. Thermostat faulty or clogged</li><li>12. Carburetor adjusts incorrect</li><li>13 Fuel pump damaged</li><li>14. Air vent screw on the fuel tank is closed</li><li>15. Choke knob is pulled out</li><li>16. Motor angle is too high</li> <li>17 Carburetor is clogged</li><li>18. Throttle valve adjusts incorrect</li><li>19. Battery lead is removed</li></ol>	<ol style="list-style-type: none"><li>1. Inspect spark plug(s). Clean or replace with recommended type.</li><li>2. Check for pinched or kinked fuel line or other obstructions in fuel system.</li> <li>3. Fill tank with clean, fresh fuel.</li><li>4. Clean or replace filter.</li><li>5. Have Yamaha dealer service.</li><li>6. Find and correct cause.</li><li>7. Inspect and adjust as specified.</li><li>8. Check wires for wear or breaks. Tighten all loose connections.</li><li>9. Clean or replace filter.</li><li>10. Check and replace it as specified.</li><li>11. Have Yamaha dealer service.</li><li>12. Have Yamaha dealer service.</li><li>13. Have Yamaha dealer service.</li><li>14. Open the air vent screw.</li> <li>15. Return to home position.</li><li>16. Return to normal operating position.</li> <li>17. Have Yamaha dealer service.</li><li>18. Have Yamaha dealer service.</li><li>19. Connect securely.</li></ol>





Trouble	Possible Cause	Remedy
D. Warning buzzer sounds or indicator lamp lights	<ol style="list-style-type: none"><li>1. Cooling system clogged</li><li>2. Engine oil level low</li><li>3. Heat range of spark plug incorrect</li><li>4. Specified engine oil not used</li><li>5. Engine oil contaminated or deteriorated</li><li>6. Oil filter clogged</li><li>7. Oil feed/injection pump malfunctions</li><li>8. Load on boat improperly distributed</li><li>9. Water pump/thermostat faulty</li></ol>	<ol style="list-style-type: none"><li>1. Check water intake for restriction.</li><li>2. Fill oil tank with specified engine oil.</li><li>3. Check the plug condition and replace it with a correct one.</li><li>4. Check and replace specified one.</li><li>5. Replace it with fresh, specified one.</li><li>6. Have Yamaha dealer service.</li><li>7. Have Yamaha dealer service.</li><li>8. Distribute load to place boat on an even plane.</li><li>9. Have Yamaha dealer service.</li></ol>
E. Engine power loss	<ol style="list-style-type: none"><li>1. Propeller damaged</li><li>2. Propeller pitch or diameter wrong</li><li>3. Trim angle incorrect</li><li>4. Motor mounted at wrong height on transom</li><li>5. Warning system activated</li><li>6. Boat bottom fouled with marine growth</li><li>7. Spark plug(s) fouled or wrong type</li><li>8. Weeds or other foreign matter tangled on gear housing</li><li>9. Fuel system obstructed</li><li>10. Fuel filter clogged</li><li>11. Fuel contaminated or stale</li><li>12. Spark plug gap incorrect</li></ol>	<ol style="list-style-type: none"><li>1. Have propeller repaired or replaced.</li><li>2. Install correct propeller to operate outboard at its recommended rpm range.</li><li>3. Adjust trim angle to gain most efficient operation.</li><li>4. Have motor adjusted to proper transom height.</li><li>5. Find and correct cause.</li><li>6. Clean boat bottom.</li><li>7. Inspect spark plug(s). Clean or replace with recommended type.</li><li>8. Remove them and clean lower unit.</li><li>9. Check for pinched or kinked fuel line or other obstructions in fuel system.</li><li>10. Clean or replace filter.</li><li>11. Fill tank with clean, fresh fuel.</li><li>12. Inspect and adjust as specified.</li></ol>



Trouble	Possible Cause	Remedy
E. Engine power loss	<ul style="list-style-type: none"><li>13. Poor connections or damaged ignition wiring</li><li>14. Failed ignition parts</li><li>15. Specified engine oil not used</li><li>16. Thermostat faulty or clogged</li><li>17. Air vent screw is closed</li><li>18. Fuel pump damaged</li><li>19. Fuel joint connection is wrong</li><li>20. Heat range of spark plug incorrect</li></ul>	<ul style="list-style-type: none"><li>13. Check wires for wear or breaks. Tighten all loose connections. Replace worn or broken wires.</li><li>14. Have Yamaha dealer service.</li><li>15. Check and replace it as specified.</li><li>16. Have Yamaha dealer service.</li><li>17. Open the air vent screw.</li><li>18. Have Yamaha dealer service.</li><li>19. Connect correctly.</li><li>20. Check the plug condition and replace it with a correct one.</li></ul>
F. Engine vibrates excessively	<ul style="list-style-type: none"><li>1. Propeller damaged</li><li>2. Propeller shaft damaged</li><li>3. Weeds or other foreign matter tangled on propeller</li><li>4. Motor mounting bolt is loose</li><li>5. Steering pivot is loose or damaged</li></ul>	<ul style="list-style-type: none"><li>1. Have propeller repaired or replace.</li><li>2. Have Yamaha dealer service.</li><li>3. Remove and clean propeller.</li><li>4. Tighten the bolt.</li><li>5. Tighten or have Yamaha dealer service.</li></ul>





EMU00416

## TEMPORARY ACTION IN EMERGENCY

EMU00417

### IMPACT DAMAGE

**⚠WARNING**

The outboard motor can be seriously damaged by a collision while operating or trailering. Damage could make the outboard motor unsafe to operate.



If the outboard motor hits any object in the water, follow the procedure below.

- 1) Stop the engine immediately.
- 2) Inspect control system and all components for damage. Also, inspect the boat damage.
- 3) However damage is found or not found, go back to a nearest harbor slowly and carefully.
- 4) Have a Yamaha dealer inspection of the outboard motor, before operating it again.

EMU00418

### RUNNING SINGLE ENGINE

Using only one of the engines in case of an emergency, be sure to keep the unused one tilted up and operate the other engine at low speed.

**CAUTION:**

If the boat is operated with one engine in the water but not running, water may run into the exhaust pipe due to wave action, causing engine trouble.

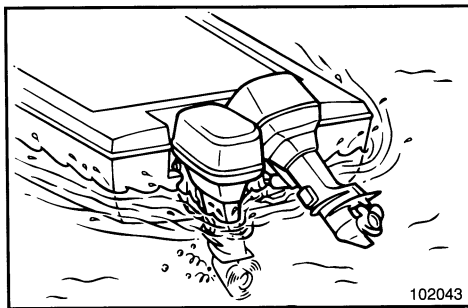
**NOTE:**

When you are maneuvering at low speed, such as near a dock, it is recommended that both engines be running with one in neutral gear if possible.

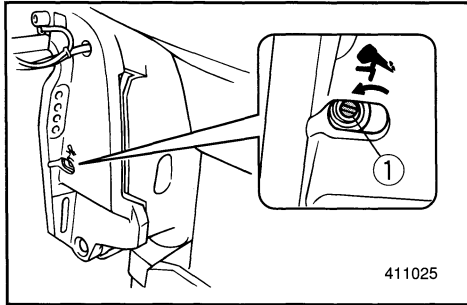

EMU00419

**POWER TRIM/TILT WILL NOT OPERATE**

If the engine cannot be tilted up or down with the power trim and tilt because of a discharged battery or a failure with the power trim and tilt unit, the engine can be tilted manually.

① Manual valve screw

EMU00421

- 1) Loosen the manual valve screw counterclockwise until it stops.
- 2) Put the engine in the desired position, then tighten the manual valve screw clockwise.





EMU00424

### **STARTER WILL NOT OPERATE**

If the starter mechanism does not operate (engine cannot be cranked with the starter), the engine can be manually started with an emergency starter rope.

However, the engine can not be manually started if the battery has low voltage. If the battery is discharged to 9 volts or below, the electrical fuel pump will not operate.

#### **⚠WARNING**

- **Use this procedure only in an emergency and only to return to port for repairs.**
- **When the emergency starter rope is used to start the engine, the start-in-gear protection device does not operate. Make sure the remote control lever is in neutral. Otherwise, the boat could unexpectedly start to move, which could result in an accident.**
- **Be sure no one is standing behind you when pulling the starter rope. It could whip behind you and injure someone.**
- **An unguarded rotating flywheel is very dangerous. Keep loose clothing and other objects away when starting the engine. Use the emergency starter rope only as instructed. Do not touch the flywheel or other moving parts when the engine is running. Do not install the starter mechanism or top cowling after the engine is running.**
- **Do not touch the ignition coil, high voltage wire, spark plug cap or other electrical components when starting or operating the motor. You could be shocked.**



EMU00430

### Emergency Starting Engine

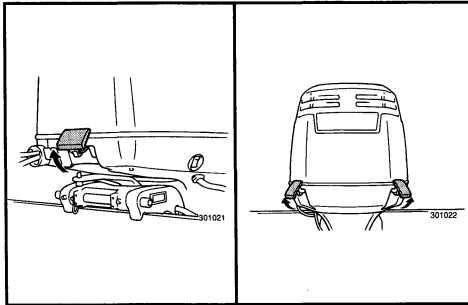

- 1) Remove the top cowling.

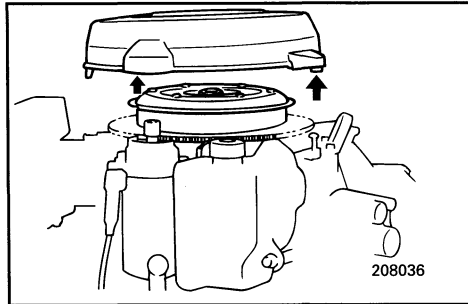

- 2) Remove the flywheel cover.
- 3) Prepare the engine for starting. See "STARTING ENGINE" for procedures. Be sure the engine is in Neutral and that the lanyard is attached to the engine stop switch.

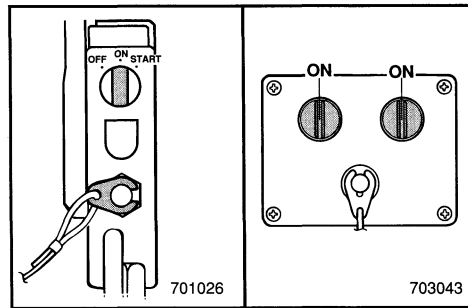

- 4) Turn the main switch to START and back to OFF several times to inject some fuel into the combustion chambers, then put the switch in the ON position.

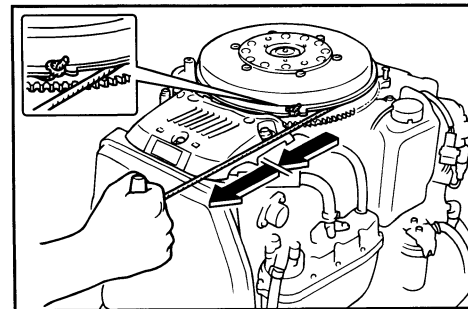

- 5) Insert the knotted end of the emergency starter rope into the notch in the flywheel rotor and wind the rope several turns clockwise.
- 6) Give a strong pull straight out to crank the engine. Repeat if necessary.

**NOTE:** \_\_\_\_\_  
If the engine will not start with this procedure, refer to "ENGINE FAILS TO OPERATE".



EMU00438

### **ENGINE FAILS TO OPERATE**

If the engine speed becomes erratic or the engine stops unexpectedly, or if the engine does not start, the following emergency circuit procedure may allow you to return to port for repairs.

Before using this procedure, be sure to check the "TROUBLESHOOTING" section. Eliminate causes such as low fuel or overheating before using this procedure.

#### **⚠WARNING**

**When the emergency circuit is used, the engine may run faster than normal at idling and low speeds. Be prepared slightly increased speeds when operating at low throttle settings.**

#### **CAUTION:**

- This emergency circuit should only be used long enough to return to port for repairs. Do not continue to operate the engine without getting repairs.
- Do not operate the engine over 3,500 r/min while using the emergency circuit because ignition timing and fuel injection settings will not adjust for higher speed operation. Engine damage can result from higher engine speed.





E

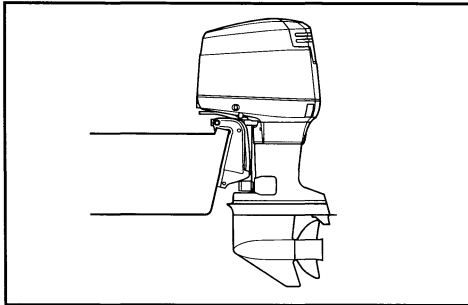

If an engine fails to start, use the following procedure.

1) Adjust the trim angle so that the engine is vertical or trimmed in.

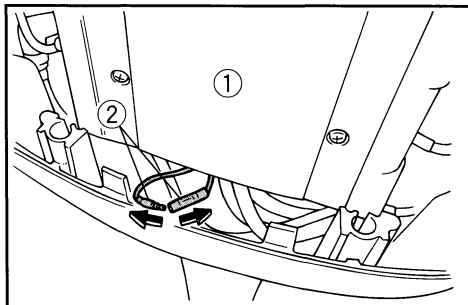

2) Disconnect the Yellow/White emergency connector. The ignition timing advance circuit of the microcomputer is bypassed.

- ① CDI unit
- ② Yellow / White cord

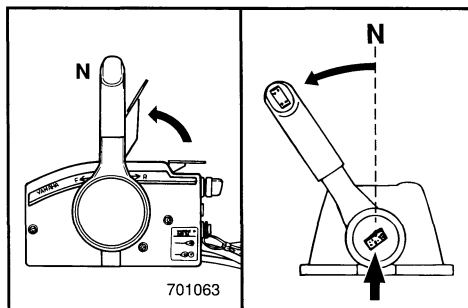

3) Open the throttle slightly without shifting using the neutral throttle lever or the free accelerator. After the engine starts, return the throttle to the original position.

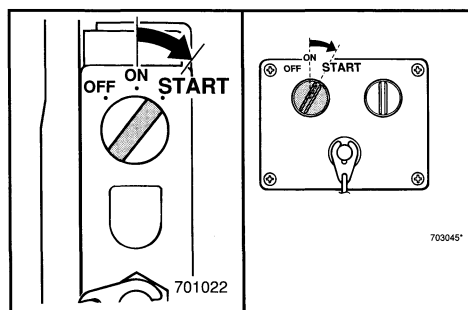

4) Be sure the engine is in Neutral and that the lanyard is attached to the engine stop switch. The main switch must be on.  
5) Start the engine.

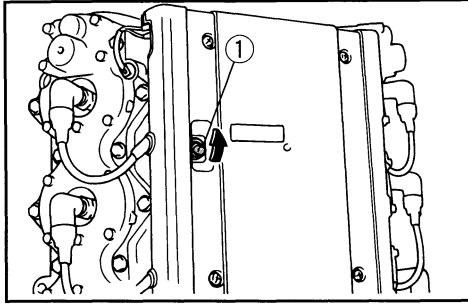

EMU00444

**LOW OIL LEVEL WARNING WORKS**

If the oil level is allowed to drop too low, the red segment will appear on the oil level indicator, the buzzer will sound, and engine speed will be limited to about 2,000 r/min. If this happens, a reserve amount of oil can be pumped from the remote oil tank (3) to the engine oil tank (2) using the emergency switch (1).

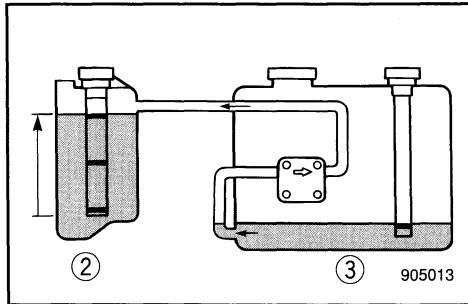
**⚠ WARNING**

Be sure to stop the engine before performing this procedure.

**CAUTION:**

- If the emergency switch is held up too long, too much oil will be pumped into the engine tank, overflowing it. Release the switch when oil reaches the upper level line on the engine oil tank.
- Do not use this emergency procedure unless the oil level warning lamps are installed and working.

- 1) Remove the top cowling.
- 2) Turn the main switch to the "ON" position.
- 3) Lift the emergency switch to pump reserve oil in remote oil tank into the engine oil tank.
- 4) After using the emergency switch, turn off the main switch, then turn it back on. This resets the warning system for normal operation. Yellow segment will remain appearing on oil level indicator at this time.
- 5) Start the engine and return to the nearest port for more oil.



E

**NOTE:**

- Reserve oil capacity is maximum 1,500 cm<sup>3</sup> (1.6 US qt, 1.31 Imp qt).
- The oil feed pump will not operate if the engine is tilted more than 35°. Put the engine in the down position before operating the emergency switch.

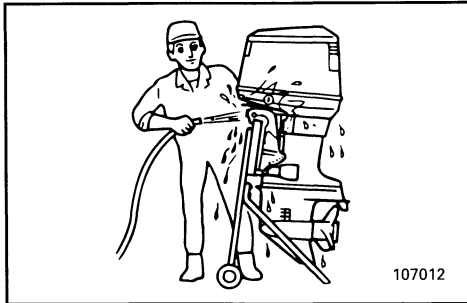

EMU00446

### TREATMENT OF SUBMERGED MOTOR

If the outboard motor is submerged, immediately take it to a Yamaha dealer. Otherwise, some corrosion may begin almost immediately.

If you cannot immediately take the outboard motor to a Yamaha dealer, follow the procedure below for taking care to minimize engine damage.

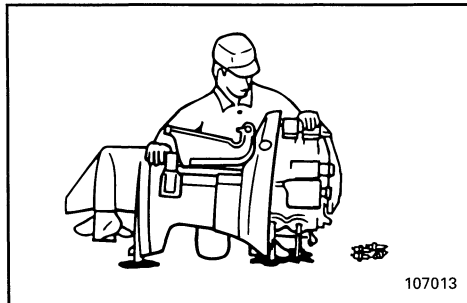

EMU00449

- 1) Thoroughly wash away mud, salt, seaweed, etc. with fresh water.
- 2) Remove the spark plugs and face the spark plug holes downward to allow any water, mud or contaminants to drain.
- 3) Drain the fuel from the vapor separator, fuel filter and fuel line.
- 4) Feed fogging oil or engine oil through the intake manifold and spark plug holes while cranking with the emergency starter rope.
- 5) Take the outboard motor to a Yamaha dealer as soon as possible.

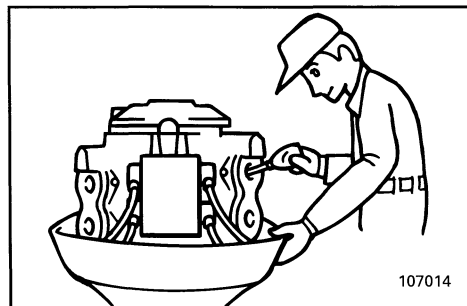

**CAUTION:** \_\_\_\_\_

**Do not attempt to run the motor until it has been completely inspected.**

\_\_\_\_\_

EMU00450

# Chapter 6

## INDEX

INDEX.....6-1

A to Z

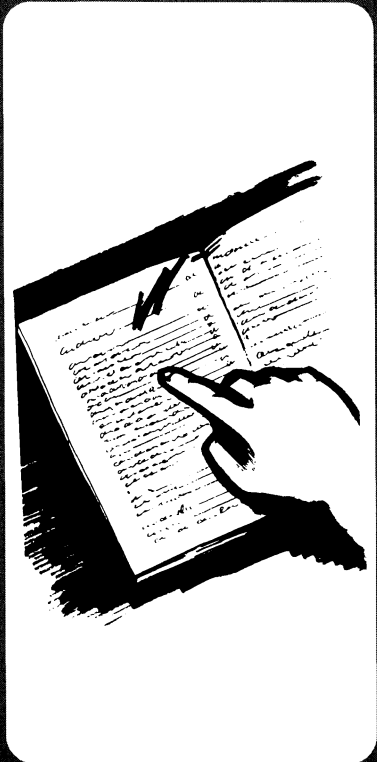

**INDEX**

**A**  
 Adjusting idling speed .....4-15  
 Adjusting trim angle .....3-19

**B**  
 Basic boating rules .....1-6  
 Battery care .....4-7  
 Battery requirement .....1-12  
 Breaking in (running in) engine .....3-10

**C**  
 Changing gear oil .....4-21  
 Checking battery .....4-23  
 Checking bolts and nuts .....4-26  
 Checking fuel system .....4-13  
 Checking painted surface of motor .....4-28  
 Checking power trim and tilt system ...4-18  
 Checking propeller .....4-19  
 Checking water trap under engine oil tank .....4-16  
 Checking wiring and connectors .....4-17  
 Cleaning and adjusting spark plug .....4-11  
 Cleaning and anti-corrosion measure ...4-6  
 Cleaning cooling-water passages .....4-27  
 Cleaning fuel filter .....4-14  
 Cleaning the outboard motor .....4-26  
 Clock .....2-12  
 Coating the boat bottom .....4-28  
 Connecting the battery .....4-24  
 Cruising in other conditions .....3-23  
 Cruising in salt water .....3-23  
 Cruising in turbid water .....3-23

**D**  
 Digital speedometer .....2-10  
 Digital tachometer .....2-9  
 Disconnecting the battery .....4-26

**E**  
 Emission control information .....1-2  
 Engine fails to operate .....5-9  
 Engine oil .....1-11  
 Engine stop lanyard switch .....2-4

Exhaust leakage .....4-17

**F**  
 Filling fuel .....3-4  
 Filling fuel and engine oil .....3-4  
 Filling fuel tank .....4-4  
 Filling oil .....3-5  
 Flushing cooling system and fogging engine .....4-5  
 Forward .....3-16  
 Free accelerator .....2-6  
 Fuel consumption meter .....2-14  
 Fuel economy .....2-15  
 Fuel flow meter .....2-14  
 Fuel management meter .....2-13  
 Fuel meter .....2-12  
 Fueling instructions .....1-10

**G**  
 Gasohol .....1-11  
 Gasoline (petrol) .....1-11  
 Greasing .....4-10

**I**  
 Identification numbers record .....1-1  
 Impact damage .....5-5  
 Important labels .....1-5  
 Index .....6-1  
 Inspecting and replacing anode(s) .....4-22  
 Installation .....3-1

**K**  
 Key number .....1-1

**L**  
 Low oil level warning works .....5-11  
 Lubrication .....4-6

**M**  
 Main components .....2-1  
 Main switch .....2-4  
 Maintenance chart .....4-9  
 Motor exterior .....4-26  
 Mounting height .....3-3  
 Mounting the outboard motor .....3-2

**N**  
 Neutral interlock trigger .....2-3

Neutral throttle lever .....	2-3	Tilting up/down .....	3-21
<b>O</b>		Top cowling lock levers.....	2-17
Oil level indicator .....	3-7	Trailing outboard motor .....	4-3
Oil level warning indicator.....	2-10	Transporting and storing outboard motor.....	4-3
Oil level warning/oil filter clogging warning .....	2-19	Treatment of submerged motor .....	5-13
Operation after a long period of storage .....	3-9	Trim meter .....	2-9
Operations of controls and other functions .....	2-2	Trim tab.....	2-7
Outboard motor serial number .....	1-1	Trimming outboard motor.....	3-18
Overheat warning .....	2-18	Trip meter .....	2-11
Overheat warning indicator.....	2-10	Troubleshooting.....	5-1
<b>P</b>		Twin engine speed synchronizer .....	2-16
Periodic maintenance.....	4-8	<b>U</b>	
Power trim and tilt switches.....	2-5, 2-8	Using a single battery .....	4-24
Power trim/tilt will not operate.....	5-6	Using an accessory battery .....	4-25
Pre-operation checks .....	3-8	<b>W</b>	
Propeller selection .....	1-12	Warming up engine .....	3-15
<b>R</b>		Warning indicator .....	2-13
Remote control.....	2-2	Warning system .....	2-18
Remote control lever .....	2-3	Warranty information .....	Next page
Replacement parts.....	4-8	Water leakage.....	4-17
Replacing fuse.....	4-16	Water separator warning indication ....	2-16
Reverse .....	3-16		
Running single engine .....	5-5		
<b>S</b>			
Safety information .....	1-3		
Shifting.....	3-16		
Specification data .....	4-1		
Speedometer.....	2-11		
Start-in-gear protection.....	1-13		
Starter will not operate.....	5-7		
Starting engine.....	3-12		
Stopping engine.....	3-17		
Storing outboard motor .....	4-4		
<b>T</b>			
Tachometer.....	2-9		
Temporary action in emergency .....	5-5		
Throttle friction adjusting screw .....	2-6		
Tilt support lever .....	2-17		

## ***IMPORTANT WARRANTY INFORMATION FOR U.S.A. AND CANADA***

**Welcome to the Yamaha Family!**

**Congratulations on the purchase of your new Yamaha marine power. Yamaha is committed to exceptional customer satisfaction, and we want your ownership experience to be a satisfying one. Please read the following warranty information to help ensure satisfaction with your Yamaha.**

Yamaha is ready to stand behind your purchase with strong warranty coverage. To be sure you receive all the benefits of warranty, please take the following steps:

1. Be sure your new Yamaha is registered for warranty. Your boat dealer should do this at the time of sale. Make sure your dealer gives you a copy of the completed Yamaha registration card for your records. If you are unsure whether or not your Yamaha is registered, complete the Warranty Registration card found inside the cover of the Owner's Manual. Mail it to the distributor for the country in which you live (see step 6 for the correct address). If your Yamaha is not properly registered, a warranty repair could be unnecessarily delayed while registration records are checked.
2. Read the Limited Warranty statement which follows these instructions. This warranty applies to Yamaha outboard motors sold in the United States, whether purchased separately or when supplied as original equipment by a boat builder. The terms also apply to original equipment packages sold in Canada, with coverage provided by Yamaha Motor Canada (see "Warranty Guide" for Canadian models). This warranty explains the conditions of the warranty, including the obligations that your dealer and you as the owner have under the warranty. For example, your Yamaha outboard must receive a proper pre-delivery inspection (PDI) by the selling dealer. Failure to take this important step could jeopardize warranty coverage!
3. If you need warranty repairs, you must take your Yamaha outboard to an authorized Yamaha outboard dealer. Be aware that not all selling boat dealers are authorized Yamaha dealers. Only authorized dealers have the factory training, special tools, and Yamaha support needed to perform warranty repairs.
4. If you are away from home, or your selling dealer is not an authorized Yamaha dealer, use the following toll-free numbers to find the nearest Yamaha dealer.

**United States Dealer Locations: 1-800-692-6242**

**Canada Dealer Locations: 1-800-267-8577**



5. Your warranty applies specifically to repairs made in the country of purchase. If your U.S.-purchased Yamaha needs warranty service while in Canada, or your Canadian purchased Yamaha needs service while in the United States, Yamaha will assist the local dealer whenever possible. However, some products available in one country may not be sold or serviced in the other.
6. If you need any additional information about your Yamaha or warranty coverage which your dealer cannot provide, please contact us directly.

**Yamaha Motor Corporation, U.S.A.**  
**P.O. Box 6555**  
**Cypress, CA 90630**  
**Attention: Customer Relations Department**

**Telephone No. (714) 761-7439**  
**Fax No. (714) 761-7559**

**Yamaha Motor Canada Ltd.**  
**480 Gordon Baker Road**  
**North York, Ontario**  
**M2H 3B4**  
**Attention: Customer Relations Department**

**Telephone No. (416) 498-1911**  
**Fax No. (416) 491-3122**

## YAMAHA MOTOR CORPORATION, U.S.A. OUTBOARD MOTOR TWO YEAR LIMITED WARRANTY

Yamaha Motor Corporation, U.S.A. is proud of its heritage and reputation for producing products with high standards of quality and workmanship. Product excellence provides the cornerstone for our commitment to customer satisfaction. The Yamaha Outboard Limited Warranty is your assurance of this commitment.

This warranty provides you with protection against the expense of repairs for your outboard motor that are required as a result of defects in materials or workmanship. When maintained and utilized in the prescribed manner, you can count on your Yamaha outboard to provide reliable service.

This warranty provides you with specific coverage and notes your responsibilities in maintaining and operating your outboard. Please take the time to read and become familiar with this warranty.

**PERIOD OF WARRANTY.** Any new Yamaha outboard motor purchased and registered with Yamaha Motor Corporation, U.S.A. for pleasure use in the United States, will be warranted against defects in material or workmanship for a period of two (2) years from date of purchase, subject to exclusions noted herein. Any Yamaha outboard motor purchased and utilized for commercial applications will be warranted for a period of one (1) year from the date of purchase, subject to exclusions noted herein. Yamaha peripheral equipment included with the motor, such as gauges, fuel tanks and hoses, remote control boxes, propellers, and wiring external from the motor unit, will be warranted for one (1) year from the date of purchase for either pleasure or commercial use. Replacement parts used in warranty repairs will be warranted for the balance of the applicable warranty period.

The second year of warranty (if applicable) shall be limited to covering the cost of parts and labor for major components only. The major components covered are:

#### **Power Unit Section**

- Power Head
- Intake Manifold and Reed Valve Assembly
- Carburetor Assembly and its Related Components
- Fuel and Oil Pump Assemblies
- Ignition System (Standard and Microcomputer)
- Precision Blend @ System

#### **Bracket Section**

- Bracket System
- Power Trim and Tilt Assembly

#### **Lower Unit Section**

- Exhaust System
- Upper Casing
- Lower Unit Assembly

The warranty described here applies to outboard motor purchased and registered for use in the United States only excluding its territories. For warranty provisions outside the United States, contact the particular country's local Yamaha distributor..

**WARRANTY REGISTRATION.** To be eligible for warranty coverage, the outboard motor must first be registered with Yamaha Motor Corporation, U.S.A. A warranty registration form is provided in the Owner's Manual with each outboard. This form must be completed and mailed to Yamaha by either the selling dealer or the purchaser. Warranty registration can also be accomplished by any authorized Yamaha outboard dealer. Upon receipt of the registration, an Owner's Warranty Card will be sent by Yamaha to the registered purchaser.

**OBTAINING REPAIRS UNDER WARRANTY.** To receive repairs under this warranty, a valid Owner's Warranty Card must be presented to an authorized Yamaha outboard dealer.

During the period of warranty, any authorized Yamaha outboard dealer will, free of charge, repair or replace, at Yamaha's option, any parts adjudged defective by Yamaha due to faulty workmanship or material from the factory. All replaced parts will become the property of Yamaha Motor Corporation, U.S.A.

**CUSTOMER'S RESPONSIBILITY.** Under the terms of this warranty, the customer will be responsible for ensuring that the outboard motor is properly operated, maintained and stored as specified in the applicable Owner's Manual.

The owner of the outboard motor shall give notice to an authorized Yamaha marine dealer of any and all apparent defects within ten (10) days of discovery and make the motor available at that time for inspection and repairs at the dealer's place of business.

**GENERAL EXCLUSIONS FROM WARRANTY.** This warranty will not cover the repair of damage if the damage is a result of abuse or neglect of the product. Examples of abuse and neglect include, but are not limited to:

1. Racing or competition use, modification of original parts, abnormal strain.
2. Lack of proper maintenance and off-season storage as described in the Owner's Manual, improper mounting of the motor, installation of parts or accessories that are not equivalent in design and quality to genuine Yamaha parts.
3. Operation of the motor at an rpm other than specified, improper propeller selection, use of lubricants, oils, and fuel/oil mixtures that are not suitable for outboard motor use.
4. Damage as a result of accidents, collisions, contact with foreign materials, or submersion.
5. Growth of marine organisms on motor surfaces.

6. Normal deterioration.

**SPECIFIC PARTS EXCLUDED FROM WARRANTY.** Parts replaced due to normal wear or routine maintenance such as oil, spark plugs, shear pins, propellers, hubs, fuel and oil filters, brushes for the starter motor and power tilt motor, water pump impellers, and anodes are not covered by warranty. Charges for removal of the motor from a boat and transporting the motor to and from an authorized Yamaha outboard dealer are excluded from warranty coverage.

Specific parts excluded from the second year of warranty (if applicable) are:

- Top and Bottom Cowling
- Electric Components (other than ignition system)
- Rubber Components (such as hoses, tubes, rubber seals, fittings, and clamps)

**TRANSFER OF WARRANTY.** Transfer of the warranty from the original purchaser to any subsequent purchaser is possible by having the motor inspected by an authorized Yamaha outboard dealer and requesting the dealer to submit a change of registration to Yamaha Motor Corporation, U.S.A. within ten (10) days of the transfer.

**YAMAHA MOTOR CORPORATION, U.S.A. MAKES NO OTHER WARRANTY OF ANY KIND, EXPRESSED OR IMPLIED. ALL IMPLIED WARRANTIES OF MERCHANTABILITY AND FITNESS FOR A PARTICULAR PURPOSE WHICH EXCEED THE OBLIGATIONS AND TIME LIMITS STATED IN THIS WARRANTY ARE HEREBY DISCLAIMED BY YAMAHA MOTOR CORPORATION, U.S.A. AND EXCLUDED FROM THIS WARRANTY.**

**SOME STATES DO NOT ALLOW LIMITATIONS ON HOW LONG AN IMPLIED WARRANTY LASTS, SO THE ABOVE LIMITATION MAY NOT APPLY TO YOU. ALSO EXCLUDED FROM THIS WARRANTY ARE ANY INCIDENTAL OR CONSEQUENTIAL DAMAGES INCLUDING LOSS OF USE. SOME STATES DO NOT ALLOW THE EXCLUSION OR LIMITATION OF INCIDENTAL OR CONSEQUENTIAL DAMAGES, SO THE ABOVE EXCLUSION MAY NOT APPLY TO YOU.**

**THIS WARRANTY GIVES YOU SPECIFIC LEGAL RIGHTS, AND YOU MAY ALSO HAVE OTHER RIGHTS WHICH VARY FROM STATE TO STATE.**

YAMAHA MOTOR CORPORATION, U.S.A.  
Post Office Box 6555  
Cypress, California 90630

#### WARRANTY QUESTIONS AND ANSWERS

Q. What costs are my responsibility during the warranty period?

A. The customer's responsibility includes all costs of normal maintenance services, non-warranty repairs, accident and collision damages.

Q. What are some examples of "abnormal" strain, neglect, or abuse?

A. These terms are general and overlap each other in areas. Specific examples include:  
Running the machine out of oil, operating the machine with a broken or damaged part which causes another part to fail, damage or failure due to improper or careless transportation, and/or tie down. If you have any specific questions on operation or maintenance, please contact your Yamaha outboard dealer for advice.

Q. Does the warranty cover incidental costs such as towing or transportation due to a failure?

A. No. The warranty is limited to repair of the machine itself.

Q. May I perform any or all of the recommended maintenance shown in the Owner's Manual instead of having the dealer do them?

A. Yes, if you are a qualified mechanic and follow the procedures specified in the Owner's and Service Manuals. We do recommend, however, that items requiring special tools or equipment be done by a Yamaha outboard dealer.

Q. Will the warranty be void or canceled if I do not operate or maintain my new outboard exactly as specified in the Owner's Manual?

A. No. The warranty on a new outboard cannot be "voided" or "canceled". However, if a particular failure is caused by operation or maintenance other than as shown in the Owner's Manual, that failure may not be covered under warranty.

Q. What responsibility does a Yamaha outboard dealer have under this warranty?

A. Each Yamaha outboard dealer is expected to:  
1. Completely set up each outboard he sells prior to delivery.  
2. Explain the operation, maintenance, and warranty requirements to your satisfaction at the time of sale, and upon your request at any later date.  
In addition, each Yamaha outboard dealer is held responsible for his setup, service and warranty repair work.

Q. Is the warranty transferable to second owners?

A. Yes. The remainder of any existing warranty can be transferred upon request. The unit has to be inspected and re-registered by an authorized Yamaha outboard dealer for the policy to remain effective.

#### **CUSTOMER SERVICE**

If your machine requires warranty service, you must take it to any authorized Yamaha outboard dealer within the continental United States. Be sure to bring your warranty registration identification or other valid proof of the original date of purchase. If a question or problem arises regarding warranty, first contact the owner of the dealership. Since all warranty matters are handled at the dealer level, this person is in the best position to help you. If you are still not satisfied and require additional assistance, please write:

YAMAHA MOTOR CORPORATION U.S.A.  
CUSTOMER RELATIONS DEPARTMENT  
P.O.Box 6555  
Cypress, California 90630

When contacting Yamaha Motor Corporation, U.S.A. don't forget to include any important information such as names, addresses, model, engine serial number, dates, and receipts.

#### **CHANGE OF ADDRESS**

The federal government requires each manufacturer of a motor vehicle to maintain a complete, up-to-date list of all first purchasers against the possibility of a safety-related defect and recall. This list is compiled from the purchase registrations sent to Yamaha Motor Corporation, U.S.A. by the selling dealer at the time of your purchase.

If you should move after you have purchased your new outboard, please advise us of your new address by sending a postcard listing your outboard model name, engine serial number, dealer number (or dealer's name) as it is shown on your warranty identification, your name and new mailing address. Mail to:

YAMAHA MOTOR CORPORATION, U.S.A.  
WARRANTY DEPARTMENT  
P.O.Box 6555  
Cypress, California 90630

This will ensure that Yamaha Motor Corporation, U.S.A. has an up-to-date registration record in accordance with federal law.

**IMPORTANT WARRANTY INFORMATION  
IF YOU USE YOUR YAMAHA OUTSIDE U.S.A. OR CANADA**

**Welcome to the Yamaha Family!**

**Congratulations on the purchase of your new Yamaha marine power. Yamaha is committed to exceptional customer satisfaction, and we want your ownership experience to be a satisfying one. Please read the following warranty information to help ensure satisfaction with your Yamaha.**

This model was manufactured as a U.S.A. specification model, and the warranty statement shown in this manual is for market. To receive the benefits of the warranty that applies to the country in which you use your Yamaha, please note the following information.

1. The warranty on this model is the same as equivalent models sold in the country where you will receive service. If you need more information about your warranty coverage or your Yamaha outside the U.S.A. or Canada, please contact an authorized Yamaha dealer in your country.
2. Keep a copy of your sales contract or invoice for the purchase of your Yamaha and present it if you need warranty repairs. This document should show the date of purchase, which is important evidence the repairing dealer will need to be sure your Yamaha is covered by warranty.
3. If your Yamaha needs warranty repairs, contact an authorized Yamaha dealer in the country where you are. He will explain how to get warranty service in that country.
4. This Yamaha model may not be sold in some countries. Therefore, in some cases your local dealer may not have all the parts or service information he may need, which may unavoidably delay repairs. If this happens, we thank you for your understanding and assure you we will attempt to resolve the situation as quickly as possible.



## Free Manuals Download Website

<http://myh66.com>

<http://usermanuals.us>

<http://www.somanuals.com>

<http://www.4manuals.cc>

<http://www.manual-lib.com>

<http://www.404manual.com>

<http://www.luxmanual.com>

<http://aubethermostatmanual.com>

Golf course search by state

<http://golfingnear.com>

Email search by domain

<http://emailbydomain.com>

Auto manuals search

<http://auto.somanuals.com>

TV manuals search

<http://tv.somanuals.com>