

SPEAKER SYSTEM

Installation Series

IF2115/AS(W), IF2112/AS(W)

OWNER'S MANUAL

Thank you for choosing this Yamaha speaker system. In order to take maximum advantage of the speaker's features and ensure optimum performance and longevity, please read this manual carefully before using the speaker system. Keep the manual in safe place for future reference.

BEDIENUNGSANLEITUNG

Vielen Dank für die Auswahl dieses Lautsprechersystems von Yamaha. Damit Sie die Eigenschaften dieses Lautsprechers optimal nutzen können, und um maximale Leistung und Lebensdauer sicherzustellen, lesen Sie bitte vor der Inbetriebnahme diese Anleitung sorgfältig durch. Bitte bewahren Sie diese Anleitung zum späteren Nachschlagen an einem sicheren Ort auf.

MODE D'EMPLOI

Nous vous remercions d'avoir acheté ces enceintes Yamaha. Pour obtenir les performances optimales de vos enceintes et garantir une longévité maximale, lisez attentivement ce mode d'emploi avant d'utiliser les enceintes. Conservez-le en lieu sûr pour pouvoir vous y référer ultérieurement.

MANUAL DE INSTRUCCIONES

Gracias por escoger este sistema de altavoces Yamaha. A fin de aprovechar al máximo las características de los altavoces y obtener un rendimiento y durabilidad óptimos, lea atentamente este manual antes de utilizar el sistema. Guarde este manual en un lugar seguro para futuras consultas.

取扱説明書

このたびは、ヤマハ製品をお買い求めいただきまして、まことにありがとうございます。スピーカーの優れた性能を十分に生かして、末永くご愛用いただくために、この取扱説明書をご使用前に必ずお読みください。

English

Deutsch

Français

Español

日本語

EN
DE
FR
ES
JA

PRECAUTIONS

PLEASE READ CAREFULLY BEFORE PROCEEDING

* Please keep this manual in a safe place for future reference.



CAUTION

Always follow the basic precautions listed below to avoid the possibility of physical injury to you or others, or damage to the device or other property. These precautions include, but are not limited to, the following:

Location

- If you use a stand, make sure to observe the following precautions in order to avoid toppling the device or causing damage to the internal components.
 - Check the stand's specifications and make sure that it is sturdy enough to support the weight of the speaker.
 - Mount only one speaker on each speaker stand.
 - Use the supplied screws if included.
 - Tighten fastening screws securely.
 - Use the speaker stands with their legs fully opened.
 - Use the stand at a height of less than 140cm.
 - Add weight such as sand bags around the stand legs to prevent them from falling over.
 - Remove the speakers from the stands before moving the stands or adjusting their height.
 - Limit the number of people around the placed stand.
- We recommend using the speaker stands manufactured by Ultimate Systems (sold separately) to support the speakers.
- Always consult qualified Yamaha service personnel if the device installation requires construction work, and make sure to observe the following precautions.
 - Choose mounting hardware and an installation location that can support the weight of the device.
 - Avoid locations that are exposed to constant vibration.
 - Make sure to use the specified hardware.
 - Inspect the device periodically.
- When transporting or moving the device, always use two or more people. Attempting to lift the device by yourself may damage your back, result in other injury, or cause damage to the device itself.
- Before moving the device, remove all connected cables.
- Do not expose the device to excessive dust or vibrations, or extreme cold or heat (such as in direct sunlight, near a heater, or in a car during the day) to prevent the possibility of panel disfiguration or damage to the internal components.
- Do not place the device in an unstable position where it might accidentally fall over.

Connections

- Before connecting the device to other devices, turn off the power for all devices. Before turning the power on or off for all devices, set all volume levels to minimum.
- Use only speaker cables for connecting speakers to the speaker jacks. Use of other types of cables may result in fire.

Handling caution

- When choosing a power amplifier to use with your speakers, make sure that its power output matches the speakers' power capacity (refer to the Specifications on page 14). Even if the amplifier's power output is lower than the speakers' power capacity, the speakers may be damaged when clipping of a high input signal occurs. The following may cause damage to speakers:
 - Feedback caused when using a microphone.
 - Continuous high sound pressure level produced by electronic instruments.
 - Continuous high-power output of distorted signals.
 - Popping noises caused by turning on equipment, or by connecting or disconnecting system components while the amplifier is turned on.
- When turning on the AC power in your audio system, always turn on the power amplifier LAST, to avoid speaker damage. When turning the power off, the power amplifier should be turned off FIRST for the same reason.
- Do not operate this device at high volume levels or at a level that is uncomfortable, since it is capable of producing sound levels that could cause permanent hearing loss. If you experience any discomfort or ringing in the ears, or suspect an hearing loss, you should consult an audiologist.

Yamaha cannot be held responsible for damage caused by improper use or modifications to the device.

* Illustrations herein are for explanatory purposes only, and may not match actual appearance during operation.

* Company names and product names herein are trademarks or registered trademarks of their respective companies.

For details on signal processor settings when driving speakers with the use of multiple power amplifiers, please refer to the web site below.

Yamaha Pro Audio global web site
<http://www.yamahaproaudio.com/>

Bi-Amp/Passive switch

Select the Bi-Amp mode (bi-amp drive) or the Passive mode (full-range drive).

CAUTION

Do not change the Bi-amp/Passive setting while the speaker is in use.

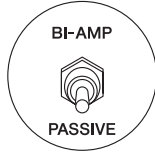

Neutrik Speakon NL4 plug wiring

Connect the plugs as shown below.

CAUTION

Be sure to use proper speaker cable – not shielded instrument or line cable – for all speaker connections.

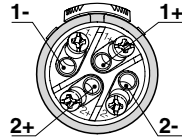

NEUTRIK plug	Bi-Amp	Passive
1+	LF+	+
1-	LF-	-
2+	HF+	
2-	HF-	

NOTE The Speakon jack and barrier strip terminals are connected in parallel.

Suspended Installation

CAUTION

- The strength of the suspension points on the speaker is **60 kg** per point (maximum).
- Before doing any installation or construction work, consult with an installation expert.
- When choosing the installation location, suspension wire and mounting hardware, make sure all are strong enough to support the weight of the speaker.
- Some fittings may deteriorate over extended periods of time due to wear and or corrosion. For optimum safety, the installation should be checked thoroughly at regular intervals.

Yamaha cannot be held responsible for damage or injury caused by insufficient strength of the support structure or improper installation.

Using eye bolts for suspension

For optimum safety, make sure to carefully follow the precautions below.

CAUTION

- Use only the supplied eye bolts.
- Use three or more eye bolts for suspended installations.
- Use the optional array frame if you intend to suspend a speaker from another suspended speaker.
- Install the eye bolts to multiple surfaces of the speaker, not just one surface.

Eye bolt strength

Keep in mind that the strength of the eye bolt differs depending on the suspension angle of the speaker. Make sure that the load for each eye bolt is less than 740 kg when suspending at an angle of 0 degrees, and less than 185 kg at an angle of 45 degrees.

CAUTION

When using the eye bolts, make sure that the suspension angle is within the range of 0 to 45 degrees, as shown below.

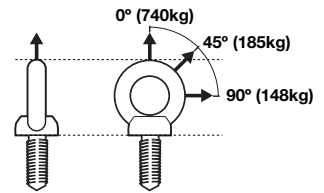

CAUTION

Do not suspend the eye bolts as shown in the diagram below.



Rotatable horn

NOTE The horn directivity of the speaker is set at the factory so that the upward spread is narrow and the downward spread is wide.

1. Remove all fixing screws on the grille, and remove the grille from the speaker.
2. Remove all screws installed on the horn, pull out the horn from the speaker, rotate the horn 90 degrees, and re-install the horn to the speaker.

CAUTION

Be careful when rotating the horn so that you do not accidentally cut the connection wires connected to the horn driver.

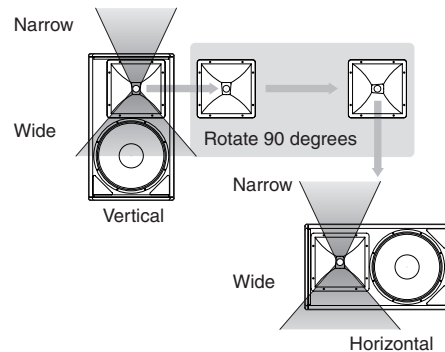

NOTE If you use the speaker as a floor monitor, change the horn dispersion so that the upward spread is wide and the downward spread is narrow, as shown in the diagram.

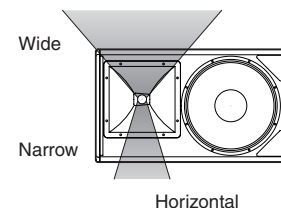

Specifications

System Type	High power 2-way full-range speaker					
Model	IF2112/AS(W)			IF2115/AS(W)		
Specifications/Drive Mode	Passive	Bi-amp		Passive	Bi-amp	
Frequency Range (-10dB) (4 π) ^{*1}	50 Hz – 20k Hz (Bi-amp mode)			45 Hz – 20k Hz (Bi-amp mode)		
Frequency Range (\pm 3dB) (4 π) ^{*1}	70 Hz – 20k Hz (Bi-amp mode)			60 Hz – 20k Hz (Bi-amp mode)		
Nominal Coverage (H x V, -6dB)	60 – 100° x 60°, can be rotated to 60° x 60 – 100°			60 – 100° x 60°, can be rotated to 60° x 60 – 100°		
Power Rating	600 W ²	LF: 700 W (AES)	HF: 110 W (AES)	600 W ²	LF: 700 W (AES)	HF: 110 W (AES)
Nominal Impedance	8 ohms	LF: 8 ohms	HF: 8 ohms	8 ohms	LF: 8 ohms	HF: 8 ohms
Sensitivity (1W@1m)	96dB SPL	LF: 96dB SPL	HF: 108dB SPL	97dB SPL	LF: 98dB SPL	HF: 108dB SPL
Calculated Peak SPL	130dB SPL	LF: 130dB SPL	HF: 134dB SPL	131dB SPL	LF: 132dB SPL	HF: 134dB SPL
Calculated Continuous SPL	124dB SPL	LF: 124dB SPL	HF: 128dB SPL	125dB SPL	LF: 126dB SPL	HF: 128dB SPL
Components						
LF	12" (30cm) Woofer, 4" (100mm) Voice Coil			15" (38cm) Woofer, 4" (100mm) Voice Coil		
HF	Rotatable Constant Directivity Horn, 1.4" (38mm) exit, 3" (76mm) Voice Coil Compression Driver			Rotatable Constant Directivity Horn, 1.4" (38mm) exit, 3" (76mm) Voice Coil Compression Driver		
Enclosure						
Dimensions (H x W x D)	695 x 378 x 333 mm (27.4 x 14.9 x 13.1 in)			770 x 448 x 374 mm (30.3 x 17.6 x 14.7 in)		
Weight	29 kg (64 lbs)			35 kg (77 lbs)		
Shape	Multi-angle wedge			Multi-angle wedge		
Material	5/8 inch (16mm), 11-ply Finnish Birch			5/8 inch (16mm), 11-ply Finnish Birch		
Finish	Textured Black (Textured White)			Textured Black (Textured White)		
Grill	16 gauge powder coated perforated steel grilles, backed with acoustically transparent reticulated foam			16 gauge powder coated perforated steel grilles, backed with acoustically transparent reticulated foam		
Connectors	2 x Neutrik NL4 and barrier strip, wired in parallel			2 x Neutrik NL4 and barrier strip, wired in parallel		
Flying Hardware	16 x M10 for shoulder eyebolts and U-bracket			16 x M10 for shoulder eyebolts and U-bracket		
Pole Mounts	One			One		
Handle	Two			Two		
Optional Accessory						
U-bracket	UB2112(W)			UB2115(W)		
Array Frame	n/a			n/a		
3rd party accessory						
Omnimount (US)	n/a			n/a		
Multimount (US, Allen products)	n/a			n/a		
Powermount (UK)	n/a			n/a		
Ohashi (Japan)	n/a			n/a		

* 1: With recommended YAMAHA DSP configuration.

* 2: 2 hrs. IEC noise.

* Specifications and descriptions in this owner's manual are for information purposes only. Yamaha Corp. reserves the right to change or modify products or specifications at any time without prior notice. Since specifications, equipment or options may not be the same in every locale, please check with your Yamaha dealer.

* Die technischen Daten und Beschreibungen in dieser Bedienungsanleitung dienen nur der Information. Yamaha Corp. behält sich das Recht vor, Produkte oder deren technische Daten jederzeit ohne vorherige Ankündigung zu verändern oder zu modifizieren. Da die technischen Daten, das Gerät selbst oder Sonderzubehör nicht in jedem Land gleich sind, setzen Sie sich im Zweifel bitte mit Ihrem Yamaha-Händler in Verbindung.

* Les caractéristiques techniques et les descriptions du mode d'emploi ne sont données que pour information. Yamaha Corp. se réserve le droit de changer ou modifier les produits et leurs caractéristiques techniques à tout moment sans aucun avis. Du fait que les caractéristiques techniques, les équipements et les options peuvent différer d'un pays à l'autre, adressez-vous au distributeur Yamaha le plus proche.

* Las especificaciones y descripciones de este manual del propietario tienen sólo el propósito de servir como información. Yamaha Corp. se reserva el derecho a efectuar cambios o modificaciones en los productos o especificaciones en cualquier momento sin previo aviso. Puesto que las especificaciones, equipos u opciones pueden no ser las mismas en todos los mercados, solicite información a su distribuidor Yamaha.

*仕様および外観は改良のため予告なく変更することがあります。

Dimensions

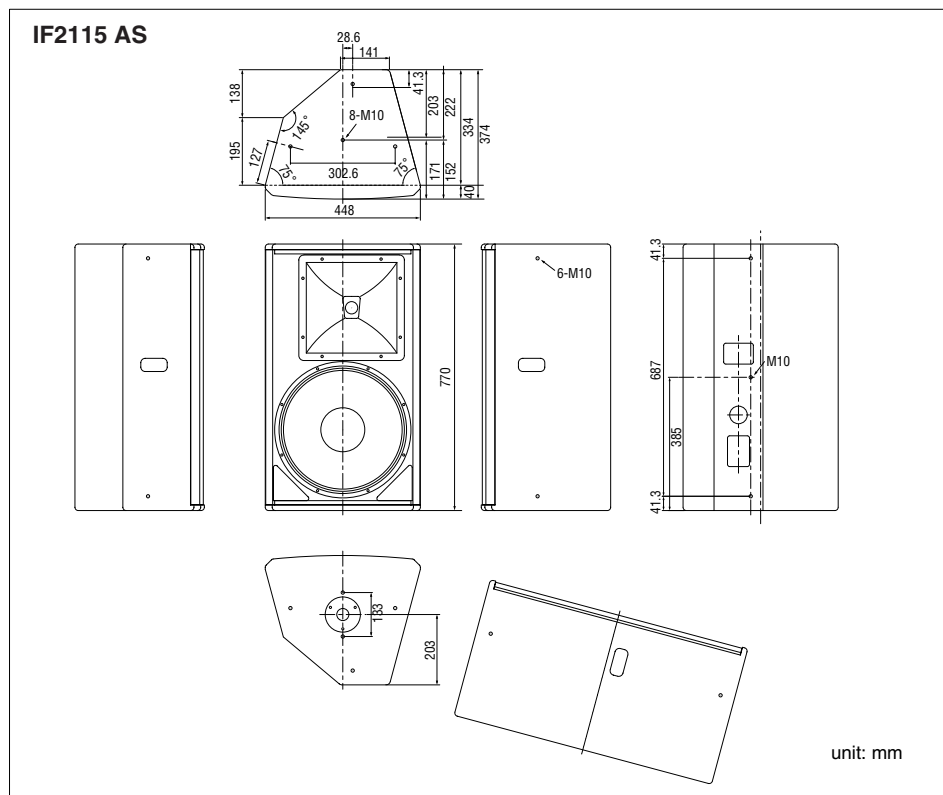
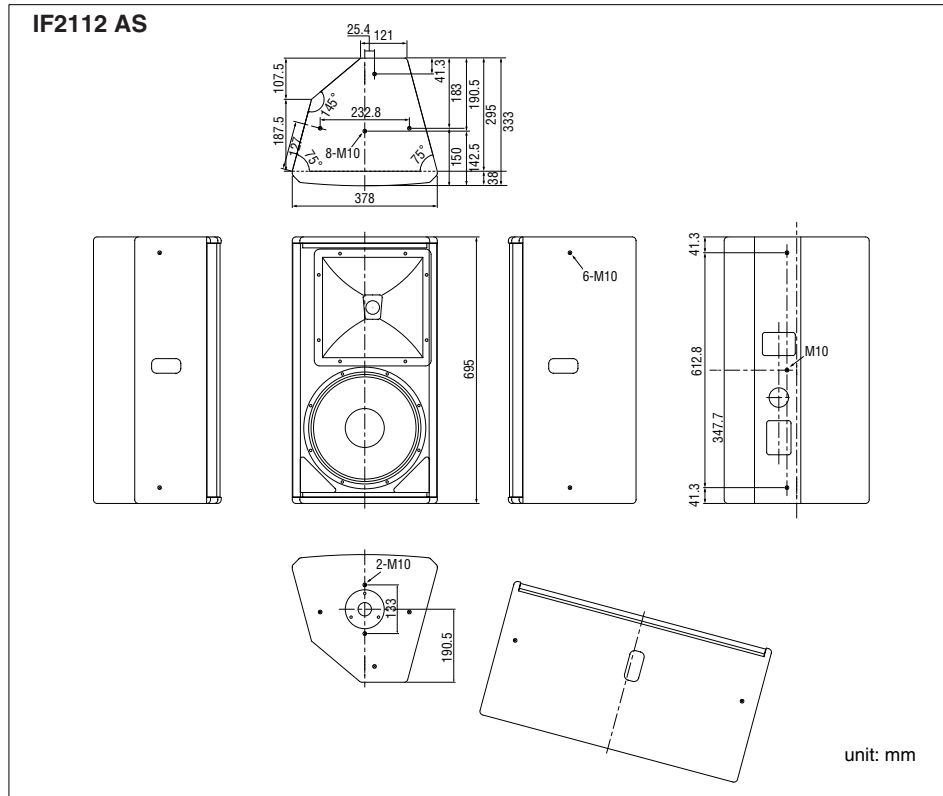

For details of products, please contact your nearest Yamaha representative or the authorized distributor listed below.

Pour plus de détails sur les produits, veuillez-vous adresser à Yamaha ou au distributeur le plus proche de vous figurant dans la liste suivante.

Die Einzelheiten zu Produkten sind bei Ihrer unten aufgeführten Niederlassung und bei Yamaha Vertragshandlern in den jeweiligen Bestimmungsländern erhältlich.

Para detalles sobre productos, contacte su tienda Yamaha más cercana o el distribuidor autorizado que se lista debajo.

NORTH AMERICA

CANADA

Yamaha Canada Music Ltd.
135 Milner Avenue, Scarborough, Ontario,
M1S 3R1, Canada
Tel: 416-298-1311

U.S.A.

Yamaha Corporation of America
6600 Orangethorpe Ave., Buena Park, Calif. 90620,
U.S.A.
Tel: 714-522-9011

CENTRAL & SOUTH AMERICA

MEXICO

Yamaha de México S.A. de C.V.
Calz. Javier Rojo Gómez #1149,
Col. Guadalupe del Moral
C.P. 09300, México, D.F., México
Tel: 55-5804-0600

BRAZIL

Yamaha Musical do Brasil Ltda.
Rua Joaquim Floriano, 913 - 4º andar, Itaim Bibi,
CEP 04534-013 Sao Paulo, SP. BRAZIL
Tel: 011-3704-1377

ARGENTINA

Yamaha Music Latin America, S.A.
Sucursal de Argentina
Viamonte 1145 Piso2-B 1053,
Buenos Aires, Argentina
Tel: 1-4371-7021

PANAMA AND OTHER LATIN AMERICAN COUNTRIES/ CARIBBEAN COUNTRIES

Yamaha Music Latin America, S.A.
Torre Banco General, Piso 7, Urbanización Marbella,
Calle 47 y Aquilino de la Guardia,
Ciudad de Panamá, Panamá
Tel: +507-269-5311

EUROPE

THE UNITED KINGDOM

Yamaha Music U.K. Ltd.
Sherbourne Drive, Tilbrook, Milton Keynes,
MK7 8BL, England
Tel: 01908-366700

GERMANY

Yamaha Music Central Europe GmbH
Siemensstraße 22-34, 25462 Rellingen, Germany
Tel: 04101-3030

SWITZERLAND/LIECHTENSTEIN

**Yamaha Music Central Europe GmbH,
Branch Switzerland**
Seefeldstrasse 94, 8008 Zürich, Switzerland
Tel: 01-383 3990

AUSTRIA

**Yamaha Music Central Europe GmbH,
Branch Austria**
Schleiergasse 20, A-1100 Wien, Austria
Tel: 01-60203900

CZECH REPUBLIC/SLOVAKIA/ HUNGARY/SLOVENIA

**Yamaha Music Central Europe GmbH,
Branch Austria, CEE Department**
Schleiergasse 20, A-1100 Wien, Austria
Tel: 01-602039025

POLAND

Yamaha Music Central Europe GmbH
Sp.z o.o. Oddział w Polsce
ul. 17 Stycznia 56, PL-02-146 Warszawa, Poland
Tel: 022-868-07-57

THE NETHERLANDS/ BELGIUM/LUXEMBOURG

**Yamaha Music Central Europe GmbH,
Branch Benelux**
Clarissenhof 5-b, 4133 AB Vianen, The Netherlands
Tel: 0347-358 040

FRANCE

Yamaha Musique France
BP 70-77312 Marne-la-Vallée Cedex 2, France
Tel: 01-64-61-4000

ITALY

Yamaha Musica Italia S.P.A.
Combo Division
Viale Italia 88, 20020 Lainate (Milano), Italy
Tel: 02-935-771

SPAIN/PORTUGAL

Yamaha Música Ibérica, S.A.
Ctra. de la Coruna km. 17, 200, 28230
Las Rozas (Madrid), Spain
Tel: 91-639-8888

SWEDEN

Yamaha Scandinavia AB
J. A. Wettergrens Gata 1, Box 30053
S-400 43 Göteborg, Sweden
Tel: 031 89 34 00

DENMARK

YS Copenhagen Liaison Office
Generatørvej 6A, DK-2730 Herlev, Denmark
Tel: 44 92 49 00

NORWAY

Norsk filial av Yamaha Scandinavia AB
Grini Næringspark 1, N-1345 Østerås, Norway
Tel: 67 16 77 70

RUSSIA

Yamaha Music (Russia)
Office 4015, entrance 2, 21/5 Kuznetskii
Most street, Moscow, 107996, Russia
Tel: 495 626 0660

OTHER EUROPEAN COUNTRIES

Yamaha Music Central Europe GmbH
Siemensstraße 22-34, 25462 Rellingen, Germany
Tel: +49-4101-3030

AFRICA

**Yamaha Corporation,
Asia-Pacific Music Marketing Group**
Nakazawa-cho 10-1, Naka-ku, Hamamatsu,
Japan 430-8650
Tel: +81-53-460-2313

MIDDLE EAST

TURKEY/CYPRUS

Yamaha Music Central Europe GmbH
Siemensstraße 22-34, 25462 Rellingen, Germany
Tel: 04101-3030

OTHER COUNTRIES

Yamaha Music Gulf FZE
LOB 16-513, P.O.Box 17328, Jubel Ali,
Dubai, United Arab Emirates
Tel: +971-4-881-5868

ASIA

THE PEOPLE'S REPUBLIC OF CHINA

Yamaha Music & Electronics (China) Co.,Ltd.
25/F., United Plaza, 1468 Nanjing Road (West),
Jingan, Shanghai, China
Tel: 021-6247-2211

INDONESIA

PT. Yamaha Music Indonesia (Distributor)
PT. Nusantik
Gedung Yamaha Music Center, Jalan Jend. Gatot
Subroto Kav. 4, Jakarta 12930, Indonesia
Tel: 21-520-2577

KOREA

Yamaha Music Korea Ltd.
8F, 9F, Dongsung Bldg. 158-9 Samsung-Dong,
Kangnam-Gu, Seoul, Korea
Tel: 080-004-0022

MALAYSIA

Yamaha Music Malaysia, Sdn., Bhd.
Lot 8, Jalan Perbandaran, 47301 Kelana Jaya,
Petaling Jaya, Selangor, Malaysia
Tel: 3-78030900

SINGAPORE

Yamaha Music Asia Pte., Ltd.
#03-11 A-Z Building
140 Paya Lebar Road, Singapore 409015
Tel: 747-4374

TAIWAN

Yamaha KHS Music Co., Ltd.
3F, #6, Sec.2, Nan Jing E. Rd. Taipei.
Taiwan 104, R.O.C.
Tel: 02-2511-8688

THAILAND

Siam Music Yamaha Co., Ltd.
891/1 Siam Motors Building, 15-16 floor
Rama 1 road, Wangmai, Pathumwan
Bangkok 10330, Thailand
Tel: 02-215-2626

OTHER ASIAN COUNTRIES

**Yamaha Corporation,
Asia-Pacific Music Marketing Group**
Nakazawa-cho 10-1, Naka-ku, Hamamatsu,
Japan 430-8650
Tel: +81-53-460-2317

OCEANIA

AUSTRALIA

Yamaha Music Australia Pty. Ltd.
Level 1, 99 Queensbridge Street, Southbank,
Victoria 3006, Australia
Tel: 3-9693-5111

COUNTRIES AND TRUST TERRITORIES IN PACIFIC OCEAN

**Yamaha Corporation,
Asia-Pacific Music Marketing Group**
Nakazawa-cho 10-1, Naka-ku, Hamamatsu,
Japan 430-8650
Tel: +81-53-460-2313

HEAD OFFICE

Yamaha Corporation, Pro Audio & Digital Musical Instrument Division
Nakazawa-cho 10-1, Naka-ku, Hamamatsu, Japan 430-8650
Tel: +81-53-460-2441

Yamaha Pro Audio global web site
<http://www.yamahaproaudio.com/>
Yamaha Manual Library
<http://www.yamaha.co.jp/manual/>

U.R.G., Pro Audio & Digital Musical Instrument Division, Yamaha Corporation
© 2005 Yamaha Corporation
WJ54050 MW-03D0

Free Manuals Download Website

<http://myh66.com>

<http://usermanuals.us>

<http://www.somanuals.com>

<http://www.4manuals.cc>

<http://www.manual-lib.com>

<http://www.404manual.com>

<http://www.luxmanual.com>

<http://aubethermostatmanual.com>

Golf course search by state

<http://golfingnear.com>

Email search by domain

<http://emailbydomain.com>

Auto manuals search

<http://auto.somanuals.com>

TV manuals search

<http://tv.somanuals.com>