

ZANUSSI



FREEZER

ZUF 105W

INSTRUCTION BOOK

GB

This instruction book contains safety precautions, information on use and helpful hints and tips.

To ensure you use this appliance effectively and safely, please read this instruction book carefully before installing or using this appliance and retain for future reference.

The symbols below help you to find things more easily:



Safety precautions

Warnings and Safety information



Hints, useful information



Environmental information



The symbol on the product or on its packaging indicates that this product may not be treated as household waste. Instead it should be taken to the appropriate collection point for the recycling of electrical and electronic equipment. By ensuring this product is disposed of correctly, you will help prevent potential negative consequences for the environment and human health, which could otherwise be caused by inappropriate waste handling of this product. For more detailed information about recycling of this product, please contact your local council, your household waste disposal service or the shop where you purchased the product.

IMPORTANT SAFETY INSTRUCTIONS

These warnings are provided in the interest of your safety. Ensure that you understand them all before installing or using this appliance. Your safety is of paramount importance. If you are unsure about any of the meanings or these warnings contact the Customer Care Department.

Prior to installation

- Check the appliance for transport damage. Under no circumstances should a damaged appliance be installed. In the event of damage please contact your retailer.

Installation

- This appliance is heavy. Care should be taken when moving it.
- It is dangerous to alter the specifications or attempt to modify this product in any way.
- Ensure that the appliance does not stand on the electrical supply cable. If the supply cable is damaged, it must be replaced by a cable available from your local Service Force Centre.
- **Make sure that the power plug has not been squashed or damaged during transit.**
 - A damaged power plug may overheat and cause a fire.
- **As you unpack the appliance, check carefully for any signs of transit damage.**
- **Do not place heavy articles or the fridge/freezer itself on the power cord.**
 - There is a risk of a short circuit and fire.
- **Do not remove the power cord by pulling on its lead, particularly when the fridge/freezer is being pulled out of its niche.**
 - Damage to the cord may cause a short-circuit, fire and/or electric shock.
 - If the power cord is damaged, it must be replaced by a certified service agent or qualified service personnel.
- **If the power plug socket is loose, do not insert the power plug.**
 - There is a risk of electric shock or fire.
- Any electrical work required to install this appliance should be carried out by a qualified electrician or competent person.
- Parts which heat up should not be exposed. Whenever possible, the back of the appliance should be close to a wall, but leaving the required distance for ventilation, as stated in the installation instructions.
- The appliance should be left for 2 hours after installation before it is turned on, in order to allow the refrigerant to settle.

Child Safety

- Do not allow children to tamper with the controls or play with the product.
- Keep packaging materials away from children, to prevent the risk of suffocation!

During Use

- This appliance is designed for domestic use only, specifically for the storage of edible foodstuffs. It is not intended for commercial or industrial use.
- Containers with flammable gases or liquids can leak at low temperatures. Do not store any containers with flammable materials, such as spray cans, fire extinguisher refill cartridges etc. in the freezer.
- Frozen food should not be refrozen once it has thawed out.
- Do not place carbonated or fizzy drinks in the freezer.
- Ice lollies can cause 'frost/freezer burns' if consumed straight from the freezer.

- Do not remove items from the freezer if your hands are damp/wet, as this could cause skin abrasions or frost/freezer burns.
- Bottles and cans must not be placed in the freezer they can burst when the contents freeze.
- Manufacturers' recommended storage times should be adhered to. Refer to relevant instructions.
- Warning: if you place frozen foods on top of the product, the interaction of cold and vapor may produce water condensate in the space below the top. If such water condensate drips on the electric components placed in that space, a short-circuit may occur and damage the product. Therefore it is forbidden to place frozen foods on top of the product.

Maintenance and Cleaning

- Before cleaning, always switch off the appliance and disconnect from the electrical supply.
- When unplugging always pull the plug from the mains socket, do not pull on the cable.

Servicing

- This product should be serviced by an authorised engineer and only genuine spare parts should be used.
- Under no circumstances should you attempt to repair the appliance yourself. Repairs carried out by inexperienced persons may cause injury or serious malfunctioning. Contact your local Service Force Centre.

At the end of the Appliance Life

- When disposing of your appliance use an authorised disposal site.
- The symbol  on the product or on its packaging indicates that this product may not be treated as household waste. Instead it should be taken to the appropriate collection point for the recycling of electrical and electronic equipment. By ensuring this product is disposed of correctly, you will help prevent potential negative consequences for the environment and human health, which could otherwise be caused by inappropriate waste handling of this product. For more detailed information about recycling of this product, please contact your local council, your household waste disposal service or the shop where you purchased the product.
- Remove the plug and ensure that any locks or catches are removed, to prevent young children being trapped inside.

Safety precautions for isobutane Warning

- The refrigerant isobutane (R 600a) is contained within the refrigerant circuit of the appliance, a natural gas with a high level of environmental compatibility, which is nevertheless flammable.
- Keep ventilation openings, in the appliance enclosure or in the built-in structure, clear of obstruction.

- Do not use mechanical devices or other means to accelerate the defrosting process, other than those recommended by the manufacturer.
- Do not damage the refrigerant circuit.
- Do not use electrical appliances inside the food storage compartments of the appliance.



The Appliance and the Environment

This appliance does not contain gases which could damage the ozone layer.

Avoid damaging the cooling unit.

The packaging used on this appliance marked with the



symbol is recyclable.

Keep this instruction book for future reference and ensure it is passed on to any new owner.

CONTENTS

Instructions for the User

Guide to use the instruction book	2
Important Safety Information	3
Instructions for the User	6
General Information	6
Description and main parts	6
Switches and indicators	7
Basket Storage	7
Operation and use	7
Installation	7
Adjusting the temperature	7
Using the Appliance	8
Freezing	8
Freezing and storage of frozen foods	8
Thawing	8
To Make Ice Cubes	8
Hints and Tips	9
Energy Saving Advice	9
In the Event of a Power Failure	9
Maintenance and Cleaning	10
Internal cleaning	10
External cleaning	10
Long-term absence	10
Automatic defrosting	10
No-Frost technology	10
Something Not Working	11
Service and Spare Parts	12
Customer Care Department	12
Guarantee Conditions	13

Instructions for the Installer

Technical Specifications	14
Installing the Appliance	14
Transportation, Unpacking	14
Location	14
Waste handling	14
Ventilation Requirements	15
Door Reversal	15
Electrical Connection	17

INSTRUCTIONS FOR THE USER

General information

This appliance is designed for the freezing and storage of frozen food in a domestic home.

To ensure correct operation, the appliance should be located where the ambient temperature is between 16-32 °C.

Description and main parts

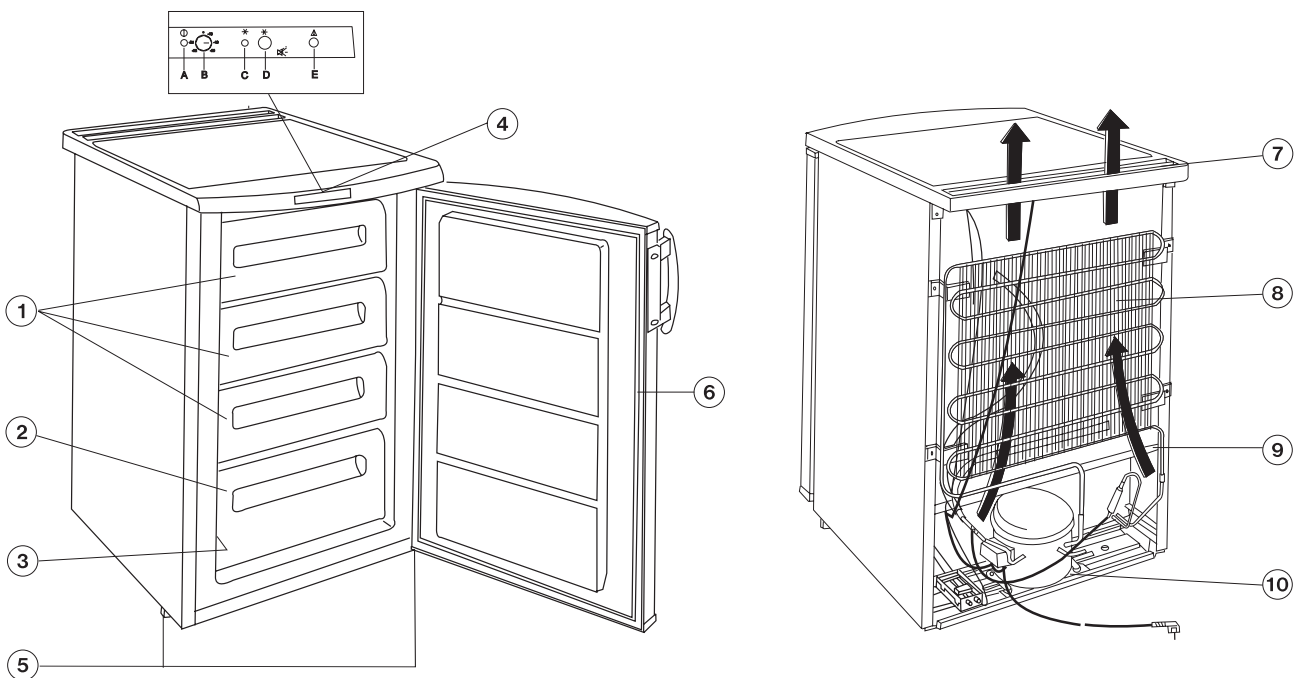

1. Freezer (baskets)

2. Freezing compartment

3. Rating plate

4. Switches and indicators

5. Adjustable feet

6. Door sealing gasket

7. Ventilation grid

8. Condenser

9. Airflow direction

10. Compressor

Switches and indicators

- A) On/off indicator green
- B) Thermostat and on/off switch
- C) Quick freeze indicator yellow
- D) Acoustic signal stop and quick freeze switch
- E) Alarm indicator red

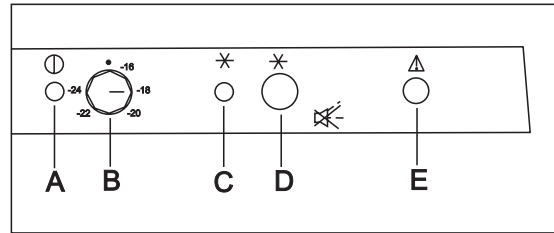

Basket Storage

Frozen food should be stored in the three lower baskets and the top compartment used for storage or fast freezing of fresh food.

Operation and use

Installation

Insert the plug into the socket. In order to switch on the product, turn the thermostat (**B**) to a temperature lower than << -16 C >>. The green, yellow and red indicators will light up. The lighting up of the on/off indicator (**A**) means that the product is switched on. The yellow indicator lights continuously indicating an uninterrupted refrigeration for 5 hours (it can be switched off manually after 2 hours). The red indicator lights continuously indicating an improper temperature in the freezing compartment. As well as an intermittent sound can be heard, which can be stopped by pressing button (**D**) once. You can switch off the freezer by turning the thermostat (**B**) to position << ● >>.

i When the product is switched on for the first time, the quick freeze function will start automatically and will stop 5 hours later. You can manually switch off this function any time by pressing the quick freeze (**D**) switch.

Adjusting the temperature

The internal temperature of the freezer is regulated electronically through five temperature positions and a switch-off << ● >> setting.

Position << -16°C >> indicates the highest (least cold) temperature, while position << -24°C >> is for the lowest (coldest) temperature. Rotate the thermostat in the desired position.

In general, it is best to set the thermostat to << -18°C >> but, for the purpose of temperature setting, you should also consider

- the temperature of the room where the product is installed,
- the frequency of door openings,
- the volume of food to be stored in the product,
- the location of the product.

Therefore, you should consider all these factors and you may have to do some testing to find the best temperature. If you want a lower temperature, turn the thermostat into a position of higher number or, vice versa, if you need a higher temperature, you should set a position of lower number. Please allow 24 hours for the freezer temperature to stabilize between two adjustments.

Alarm (red) indicator

The temperature alarm indicator **(E)** will light up when the internal temperature of the freezer increases to a level (above -12°C) where the long-term conservation of the foods is not ensured. Please note that, when switching on the freezer for the first time, the alarm indicator will remain lit until the internal temperature has reached a level required for the safe conservation of frozen food.

Temperature problem:

Under normal operating conditions, the internal temperature of the freezer will ensure the long-term conservation of the stored food. When such temperature rises above a certain level (-12°C), it will trigger an acoustic and light alarm. The light alarm is a continuous red light **(E)**, while the acoustic alarm is an intermittent sound. You can stop the acoustic alarm by pressing switch **(D)** once.

Freezing

Prepare the various foods properly and then freeze them always in the freezing compartment.

For using the quick freeze function, press the quick freeze on/off switch **(D)** for 2-3 seconds; in the case of small and great food volumes you should do it approx. 4 and 24 hours, respectively, before you want to freeze the fresh food. The yellow indicator **(C)** will light up. The compressor will operate continuously until the product reaches the freezing temperature.

Once the food is completely frozen (it may take up to 24 hours) you can manually switch off the quick freeze function by pressing the switch **(D)** for 2-3 seconds. If not switched off manually, the quick freeze function will be automatically switched off 48 hours later. The yellow indicator **(C)** will also go out.

Freezing and storage of frozen foods

- As freezing with "No-Frost" technology is quicker, the foods frozen this way will preserve their original form, nutritional value and taste even after thawing.
- Place the foods to be frozen in the lower part of the appliance.
- For the perfect operation of the appliance, make sure that the frozen foods will not touch the

ventilator cover or the ventilator mounted in the rear of the product.

- For the best results it is recommended to distribute the frozen foods evenly in the boxes.
- If you make small portions of the foods, the freezing process will take less time and subsequent thawing will be possible in small portions also.
- In order to avoid freezing burns, do not touch ice-creams immediately after they have been taken out from the freezer.
- It is recommended to state the freezing date on the package so that later you can check the storage duration.
- The time of transportation from the seller to the consumer must be as short as possible.



Important

Do not put carbonated liquids in the freezer.

Ice lollies, if consumed immediately after removal from the freezer can cause a low temperature skin burn.

Do not remove items from the freezer if your hands are damp/wet, as this could cause skin abrasions or frost/freezer burns.

In the event of a power cut the food in the freezer will not be affected if the power cut is short and the freezer is full. Do not open the lid. Should the food begin to thaw it must be consumed quickly and must not be re-frozen. (See Hints and Tips)

Thawing

Deep frozen or frozen food, prior to being used, can be thawed in a fridge or at room temperature, depending on the time available. Small food items may even be cooked from frozen, in this case cooking will take longer.

Any frozen food which is allowed to thaw accidentally should either be eaten as soon as possible, or thrown away. Alternatively, if the food is uncooked and has not been completely defrosted it can be cooked and then refrozen.



Defrosted cooked food must never be refrozen.



To Make Ice Cubes

1. Fill the ice cube tray 3/4 full with cold water, place in the freezing compartment and leave to freeze.
2. To remove the cubes twist the tray or hold it under running water for a few seconds.



Never try to free an ice tray that is frozen to the freezer compartment by using pointed or sharp edged objects.

Hints & Tips

Energy Saving Advice

- Do not install the appliance close to sources of heat, such as a boiler or radiator.
- Locate the appliance in a cool well ventilated room and make sure that the air openings of the appliance are not obstructed.
- Avoid unnecessary frosting in the cabinet by packing all foodstuffs into airtight packages before placing them in the freezer.
- Food which is to be frozen (when cool) should be placed in the fridge before being transferred to the freezer.
- Try to avoid keeping the door open for long periods or opening the door too frequently as warm air will enter the cabinet and cause the compressor to switch on unnecessarily.
- Ensure there are no obstructions preventing the door from closing properly.

In the Event of a Power Failure

If there is a power failure during the storage of frozen foods, keep the door closed. If the temperature within your freezer should rise, do not refreeze the food without checking its condition. The following guidelines should assist you:

Ice Cream: Once thawed should be discarded.

Fruits & Vegetables: If soft should be cooked and used up.

Breads & Cakes: Can be refrozen without danger.

Shellfish: Should be refrigerated and used up quickly.

Cooked Dishes: i.e. casseroles should be refrigerated and used up.

Large Pieces of Meat: Can be refrozen providing there are still ice crystals remaining within them.

Small Joints: Should be cooked and can then be refrozen as cooked dishes.

Chicken: Should also be cooked and refrozen as a fresh dish.

Maintenance & Cleaning



Before any maintenance or cleaning is carried out you must DISCONNECT the appliance from the electricity supply.

Internal Cleaning

Clean the inside and accessories with warm water and bicarbonate of soda (5 ml to 0.5 litre of water).

Rinse and dry thoroughly.



NEVER use detergents, abrasive powders, highly perfumed cleaning products or wax polishes to clean the interior as these will damage the surface and leave a strong odour.

External Cleaning

Wash the outer cabinet with warm soapy water.

Once or twice a year dust the condenser (black grille) and the compressor at the back of the appliance with a brush or vacuum cleaner, as an accumulation of dust will affect the performance of the appliance and cause excessive electricity consumption.

Long-term absence

If you do not use the product for longer periods, make sure to perform the following:

Set the thermostat to position << ● >>.

Disconnect the product from the mains.

Remove all foods from the product.

Perform defrosting and cleaning operations as described above.

Leave the doors ajar to avoid the build-up of unpleasant odors.

Automatic defrosting

This product is designed to avoid the formation of ice in the freezer. Accordingly, there is no need for manual defrosting. The product will automatically perform any defrosting once it becomes necessary.

No-Frost technology

In order to facilitate the removal of the ice layer, the evaporator is assisted by electric heating during the defrosting procedure. The ventilator is in OFF position. The defrost water will drip in the tray placed on the compressor and will evaporate. In the course of the defrosting procedure (approx. 30 minutes) the evaporator becomes warm but it has no influence on the internal temperature.

The foods should be kept well-packed in order to avoid any moisture loss as a result of air circulation.

Do not obstruct the vent holes because otherwise the operation of the product may be compromised.

For such purpose it is recommended to put all foods in the baskets in the freezer compartment.

Something Not Working

If the appliance is not working correctly, please carry out the following checks before contacting your local Zanussi Service Force Centre.

Problem	Possible Cause	Solution
No power to the appliance	No power at the socket. There is a power cut. The fuse has blown. Thermostat control knob is set at „0“.	Check there is power at the socket. Check there is not a power cut by checking the household lights. Check the fuse has not blown. Check the thermostat control knob setting.
The temperature in the appliance is too high	The appliance is located in an unsuitable position. The thermostat control knob is set too low.	Check the ambient temperature is within the appliances operating limits of 16 °C to 32 °C. Check that the thermostat control knob is turned to the correct setting relative to ambient conditions.
The temperature in the appliance is too low	The thermostat control knob is set too high.	Set the thermostat control knob to a lower position.
Excessive frost and ice has built up	The door has been left open. Something is obstructing the door. The door gasket is dirty.	Check the door has not been left open. Check nothing is preventing the door from closing. Check the door gasket is intact and clean.
The appliance is noisy.	The appliance is not level.	Check if the appliance stands stable (all four feet should be on the floor).

If after the above checks your appliance still does not operate correctly, contact your local Service Force Centre.

Please note that it will be necessary to provide proof of purchase for any in-guarantee service calls.

In-guarantee customers should ensure that the above checks have been made, as the engineer will make a charge if the fault is not a mechanical or electrical breakdown.

Power or operation failure:

In case of power failure during the storage of frozen foods, make sure not to open the freezer door. Once the power failure is over, the yellow indicator (3) of the quick freeze function will light up and then, 5 hours after restart, it will automatically go out.

If a short power failure occurs (max. 13 hours) and the product is full, the stored foods will not deteriorate. Otherwise you must use the stored food as soon as possible (if the temperature of the frozen foods rises, their storability will be shorter).

Check stability of product support (all four feet should stand on floor).

If you fail to remedy a problem, please contact the nearest Service Force Centre.

Operation failure

When the electronic system fails to detect the ACTUAL temperature, the alarm indicator will start to flash. The product will continue to operate with the use of a reserve system until the problem is eliminated by the local Service Force agent.

Service and Spare Parts

In the event of your appliance requiring service, or if you wish to purchase spare parts, please contact your local Service Force Centre by telephoning:-

08705 929929

Your telephone call will be automatically routed to the Service Force Centre covering your post code area.

For the address of your local Service Force Centre and further information about Service Force, please visit the website at www.serviceforce.co.uk

Before calling out an engineer, please ensure you have read the details under the heading "Something Not Working."

When you contact the Service Force Centre you will need to give the following details:

1. Your name, address and post code
2. Your telephone number
3. Clear and concise details of the fault
4. The model and serial number of the appliance (found on the rating plate)
5. The purchase date

Please note that a valid purchase receipt or guarantee documentation is required for in-guarantee service calls.

Customer Care Department

For general enquiries concerning your Zanussi - Electrolux appliance or for further information on Zanussi - Electrolux products, please contact our Customer Care Department by letter or telephone at the addresses below or visit our website at www.zanussi-electrolux.co.uk

Customer Services Department

Major Appliances

Zanussi - Electrolux

Addington Way

Luton

Bedfordshire

LU4 9QQ

08705727727

*calls to this number may be recorded for training purposes.

For Customer Service in Ireland please contact us at the address below:

Zanussi - Electrolux

Electrolux Group (Irl) Ltd

Long Mile Road

Dublin 12

Republic of Ireland

Tel.: +353 (0) 1 4090751

Email: service.eid@electrolux.ie

Guarantee Conditions

We Zanussi - Electrolux undertake that if within 12 months of the date of the purchase this ZANUSSI - ELECTROLUX appliance or any part thereof is proved to be defective by reason only of faulty workmanship or materials, the company will, at our option repair or replace the same FREE OF CHARGE for labour, materials or carriage on condition that:

- The appliance has been correctly installed and used only on the electrical supply stated on the rating plate.
- The appliance has been used for normal domestic purposes only, and in accordance with the manufacturer's instructions.
- The appliance has not been serviced, maintained, repaired, taken apart or tampered with by any person not authorised by us.
- All service work under this guarantee must be undertaken by a Service Force Centre.
- Any appliance or defective part replaced shall become the Company's property.

Home visits are made between **8.30am** and **5.30pm Monday to Friday**. Visits may be available outside these hours in which case a premium will be charged.

EXCLUSIONS

This Guarantee does not cover:

Damage or calls resulting from transportation, improper use or neglect, the replacement of any light bulbs or removable parts of glass or plastic.

- Costs incurred for calls to put right an appliance improperly installed or calls to appliances outside the United Kingdom.
- Appliances found to be in use within a commercial environment, plus those which are the subject of rental agreements.
- Products of Zanussi - Electrolux manufacture which are not marketed by Zanussi - Electrolux.

The guarantee is in addition to your statutory and legal rights.

EUROPEAN GUARANTEE

If you should move to another country within Europe then your guarantee moves with you to your new home subject to the following qualifications:

- The guarantee starts from the date you first purchased your product.
- The guarantee is for the same period and to the same extent for labour and parts as exists in the new country of use for this brand or range of products.
- This guarantee relates to you and cannot be transferred to another user.
- Your new home is within the European Community (EC) or European Free Trade Area.
- The product is installed and used in accordance with our instructions and is only used domestically, i.e. a normal household.
- The product is installed taking into account regulations in your new country.

Before you move please contact your nearest Customer Care Centre, listed below, to give them details of your new home. They will then ensure that the local Service Organisation is aware of your move and able to look after you and your appliances.

France	Senlis	+33 (0) 344 62 29 29
Germany	Nuremberg	+49 (0) 800 234 7378
Italy	Pordenone	+39 (0) 0434 39 4700
Sweden	Stockholm	+46 (0) 8 672 53 90
UK	Luton	+44 (0) 8705 727727
Ireland	Dublin	+353 (0) 1 4090751

Instructions for the Installer

Technical Specifications

Model	ZUF 105W
Gross capacity (l)	100
Net capacity (l)	80
Width (mm)	595
Height (mm)	850
Depth (mm)	635
Energy consumption (kWh/day)	0.575
(kWh/year)	210
Energy class, according to EU Standards	A
Freezing capacity (kg/24h)	9
Rising time (h)	13
Rated current (A)	0,5
Weight (kg)	40

Installing the appliance

Transportation, unpacking

The appliance and the interior fitting are protected for transport.

- Remove all packaging and any adhesive tape.
- Any remnants of adhesive can be removed using white spirit.
- After transportation the appliance must not be switched on for 2 hours. This is to allow the refrigerant to settle.

Waste handling

Packing materials

- The materials marked with are reusable.

>PE< PE= polyethylene

>PS< PS= polystyrene

>PP< PP= polypropylene

The packing consists of reusable materials only.

Cleaning

Clean the accessories and the inside of the appliance with warm water and bicarbonate of soda (5 ml to 0.5 litres of water). Rinse and dry thoroughly.

Do not use detergents, abrasive powders, highly perfumed cleaning products, wax polishes or cleaning products containing bleach or alcohol.

Location

The appliance should be positioned in a well ventilated, dry room.

Energy use is affected by the ambient temperature.

The appliance should therefore:

- not be installed next to radiators, cookers or other sources of heat
- only be installed at a location where the ambient temperature corresponds to the climate classification, for which the appliance is designed.

The climate classification can be found on the rating plate.

The following table shows which ambient temperature is correct for each climate classification:

Climate Classification	Ambient Temperature
SN	+10 to +32 °C
N	+16 to +32 °C
ST	+18 to +38 °C

Ventilation Requirements

The appliance must have adequate ventilation to ensure correct operation.

Diagram shows the ventilation requirements when installed:

A* Under a worktop, or cupboard.

* The clearance space of 10 cm above the appliance may be reduced to 5 cm providing a clearance space 2.5 cm is left on either side of the appliance.

B When freestanding

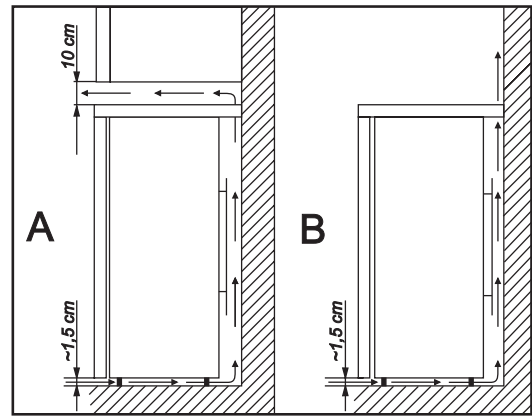

Door Reversal

If required the door can be reversed, hinged from the left, opening from the right.

To reverse the bottom hinge assembly proceed as follows:

- Disconnect the appliance from the electricity supply.
- Tilt the appliance backwards, resting the top edge of the appliance on a stool or something similar.
- Unscrew the 2 adjustable feet. Unscrew the 3 screws holding the lower door bracket. transfer the lower door hinge pin to the alternative position as shown in the top drawing. Unscrew the single screw at the bottom left hand side and retain. Replace the lower door bracket on the bottom left hand side but do not fully tighten the 3 screws.

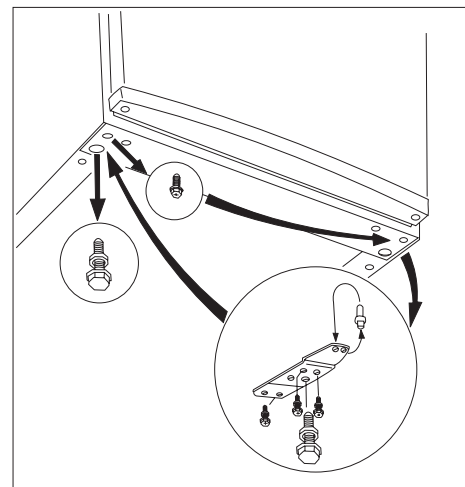

- Remove the fridge door by gently pulling downwards and store to avoid damage.
- Unscrew the top door hinge pin of the refrigerator then screw it back on the other side. As shown in the second drawing.
- Replace the fridge door on the upper door hinge pin.
- Insert the lower door hinge pin into the door and tighten all screws.
- Re-fix the retained screw to the bottom right hand side and replace the 2 adjustable feet.
- Lift the fridge back onto its feet and check it is set level and the door seal meets the fridge all around the door.

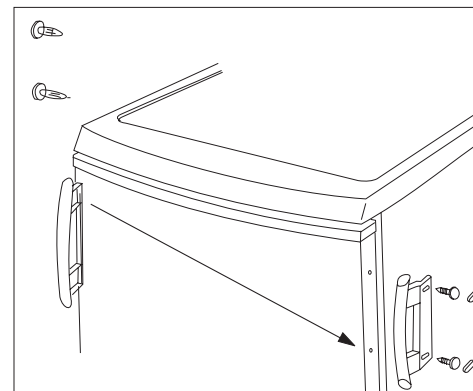
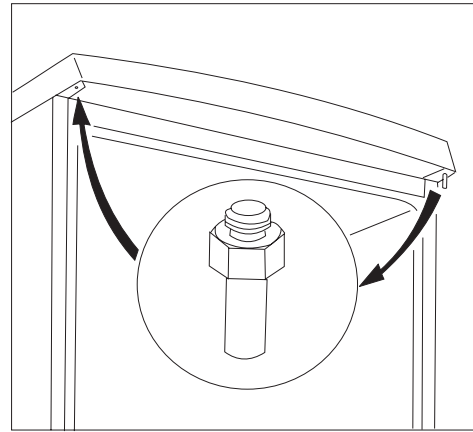

- Transfer the handle to the opposite side and place the plastic covering inserts, (supplied in the plastic bag of this instruction book) into the vacant handle fixing holes.
- Reconnect the fridge to the electricity supply.

Electrical Connection

 Any electrical work required to install this appliance should be carried out by a qualified electrician or competent person.

This appliance must be earthed.

The manufacturer declines any liability should these safety measures not be observed.

Electrical Requirements

Before switching on, make sure the electricity supply voltage is the same as that indicated on the appliance rating plate.

The appliance is supplied with a 13 amp plug fitted. In the event of having to change the fuse in the plug supplied, a 13 amp ASTA approved (BS 1362) fuse must be used. Should the plug need to be replaced for any reason. The wires in the mains lead are coloured in accordance with the following code:

Green and Yellow:	Earth
Blue:	Neutral
Brown:	Live

The wire coloured green and yellow must be connected to the terminal marked with the letter "E" or by the earth symbol  or coloured green and yellow.

The wire coloured blue must be connected to the terminal "N" or coloured black.

The wire coloured brown must be connected to the terminal marked "L" or coloured red.

Upon completion there must be no cut, or stray strands of wire present and the cord clamp must be secure over the outer sheath.

Important!

The plug must still be accessible after the appliance has been installed.

The appliance should not be connected to the electrical supply by means of an extension cable.

In case that the electrical cable has to be replaced, please contact your local Service Force Centre.

Warning!

A cut off plug inserted into a 13 amp socket is a serious safety (shock) hazard. Ensure that it is disposed of safely.

 This appliance complies with the following E.E.C. Directives:

- **73/23 EEC** of 19.02.73 (Low Voltage Directive) and subsequent modifications,
- **89/336 EEC** of 03.05.89 (Electromagnetic Compatibility Directive) and subsequent modifications.

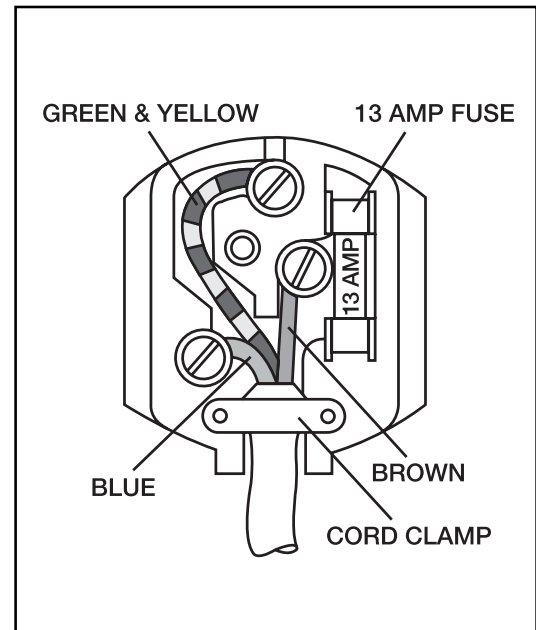

© Electrolux plc 2007

ELECTROLUX HOME PRODUCTS OPERATIONS EUROPE

 **From the Electrolux Group. The world's No.1 choice.**

The Electrolux Group is the world's largest producer of powered appliances for kitchen, cleaning and outdoor use. More than 55 million Electrolux Group products (such as refrigerators, cookers, washing machines, vacuum cleaners, chain saws and lawn mowers) are sold each year to a value of approx. USD 14 billion in more than 150 countries around the world.

Download from www.Somanuals.com. All Manuals Search And Download.

Free Manuals Download Website

<http://myh66.com>

<http://usermanuals.us>

<http://www.somanuals.com>

<http://www.4manuals.cc>

<http://www.manual-lib.com>

<http://www.404manual.com>

<http://www.luxmanual.com>

<http://aubethermostatmanual.com>

Golf course search by state

<http://golfingnear.com>

Email search by domain

<http://emailbydomain.com>

Auto manuals search

<http://auto.somanuals.com>

TV manuals search

<http://tv.somanuals.com>