



JACKSHAFT MOTOR-CONTROL SYSTEM

FOR
RESIDENTIAL GARAGE DOORS

Model 815-RL
Installation Instructions

WARNING: To reduce the risk of injury to persons, use this operator only with a residential sectional door.

**FOR INSTALLATION ONLY BY
QUALIFIED PERSONNEL**

ZAP CONTROLS UK

100 Waterloo Boulevard
Anglesey Business Park
Cannock
Staffordshire WS12 1NR
United Kingdom

August 2006



IMPORTANT INSTALLATION INSTRUCTIONS

WARNING:
To reduce the risk of Injury or death

READ AND FOLLOW ALL INSTALLATION INSTRUCTIONS

Install only on a properly balanced door. An improperly balanced door has the potential to inflict severe injury. Have a qualified service person make repairs to cables, spring assemblies, and other hardware before installing the opener.

Remove all ropes and remove, or make inoperative, all locks connected to the garage door before installing opener.

Where possible, install the door opener 7ft (2.1m) or more above the floor. Mount the emergency Manual Over-Ride Lever 6ft (1.8m) above the floor.

Do not connect the opener to power until instructed to do so.

Locate the control unit:

- (a): Within sight of the door,
- (b): At a min height of 5ft so small children cannot reach it, and
- (c): Away from all moving parts.

Install the entrapment label next to the control button in a prominent location using a suitable secure mechanical means if necessary. Attach the emergency release marking on the emergency release cable or next to the emergency release.

After installing the opener, the door must reverse when it contacts a 1½" high object (or a 2" by 4" board laid on the floor).

The maximum door size should not exceed 160 square feet (15 sq mtrs). The maximum door weight should not exceed 500 pounds (230 Kgm).

FOR INTERNAL INSTALLATION ONLY



CONTENTS

Product Overview	1
Description	2
Fitting the Super-Drive	3
Fitting the Manual Over-Ride lever	5
Fitting the Control unit	7
Fitting the Motor Cover kit	8
Connecting the mains power supply	9
Testing the door operation	11
Door speed change point and limit of travel calibration	12
Safety circuit and Photo-Eye wiring	14/15
Interlock circuit wiring	16
Accessory Radio Receiver wiring	16
Programming	16
Zap Transmitter code programming	17
Auto-Close timer programming	18
Wiring diagrams	19
Fault Finding Guide	22



ZAP SUPER-DRIVE MOTOR-CONTROL SYSTEM FOR SECTIONAL DOORS

The system includes model 800-R wall-mounting Control unit, Super-Drive jackshaft Operator, Motor Cover kit and Manual Over-Ride kit.

PRODUCT OVERVIEW



CONTROL UNIT model 800-R

Integrated Control unit with case mounted control button. This Control unit will power doors up to 15 square metres (160 square feet) in conjunction with model 8472 Operator.



JACKSHAFT SUPER-DRIVE OPERATOR model 8472

The Super-Drive Operator incorporates a V-belt drive with a Bowden cable v-belt tensioning device, which eliminates strain on the jackshaft, which is of particular benefit for applications fitted with a hollow shaft.



MANUAL OVER- RIDE model ZA0093

The Manual Over-Ride drive release mechanism includes a Doorframe or track mounted over centre lever, which is connected to the Operator by a Bowden cable. The screw hook on the lever provides adjustment of the v-belt tension.

MOTOR COVER KIT model ZA0094

The Motor Cover front simply clips onto the motor body. The Cover back is easily secured to the cover front with screws.

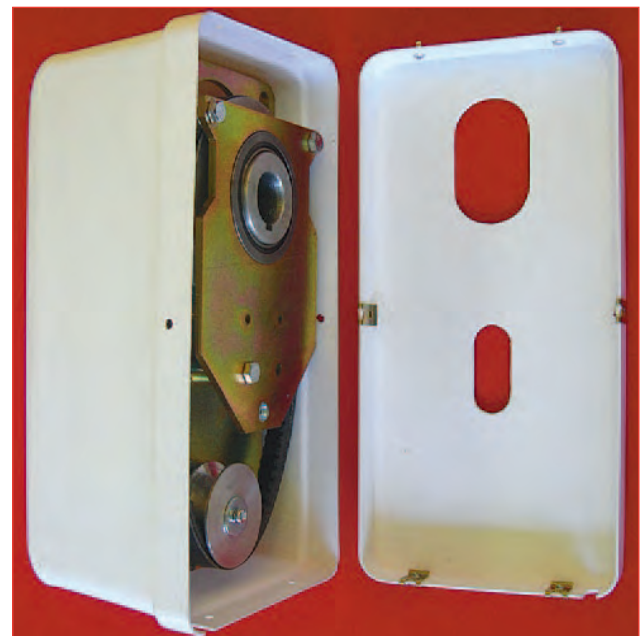

PLUG-IN BEEPER MODULE model 850 (OPTIONAL)

The Plug-in Beeper module is useful as an aid during the initial setting up and programming of the control system.

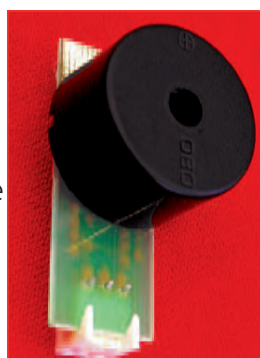

JACKSHAFT MOTOR-CONTROL SYSTEM FOR RESIDENTIAL GARAGE DOORS

Model 815-RL Installation Instructions

The Zap Controls' range of Motor-Control Systems for Sectional Doors provides a new concept in safety control and the elimination of the inherent problems with a number of features of existing door Operators.

The Zap 815-RL low voltage DC Motor-Control operates without limit switches and without a safety edge.

The control unit monitors the motor load and interprets a sudden increase in load as either an obstruction or the limit of door travel.

A significant advantage of the Zap drive system with its fast obstruction sensing, is that when an object obstructs the doors travel, the cables should never jump off the cable drums.

The motor is controlled with a very soft start to minimise any tendency for the counterbalance cables to slacken during the start of the close cycle when the door is operated without buffer springs.

It is possible for the door to be operated without buffer springs, even on a low headroom door with a rear-mounted jackshaft, providing the door closes smoothly under the influence of gravity during the close rotation of the jackshaft.



Pic 1

It is preferable to set the overhead track angle at a gradient above horizontal to increase the influence of gravity on the initial movement of the door in the close direction. If there is any indication of the door resisting movement under the influence of gravity then it may be preferable to fit a set of buffer springs or leaf springs at the fully open track position to provide an initial push to start the door moving. **(Pic 1)**

The Controller will sense the open position of the door when the counterbalance cables are pulled tight at the radius of the track. **(Pic 2)**

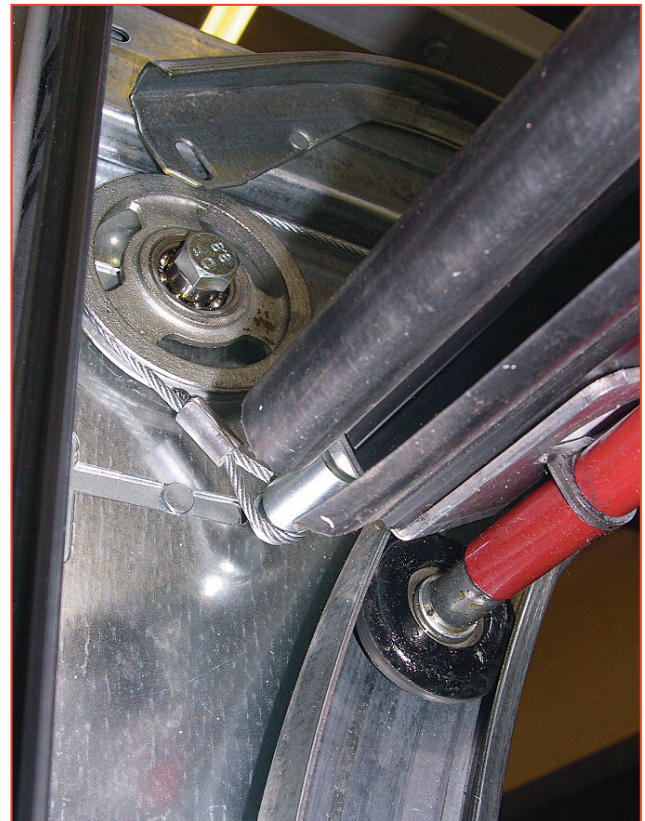

Pic 2

The model 815-RL includes the model 800-R Control Unit, model 8472 Super-Drive Operator, model ZA0093 Manual Over-Ride kit and model ZA0094 clip-on Motor Cover kit. **(Pic 3 overleaf).**

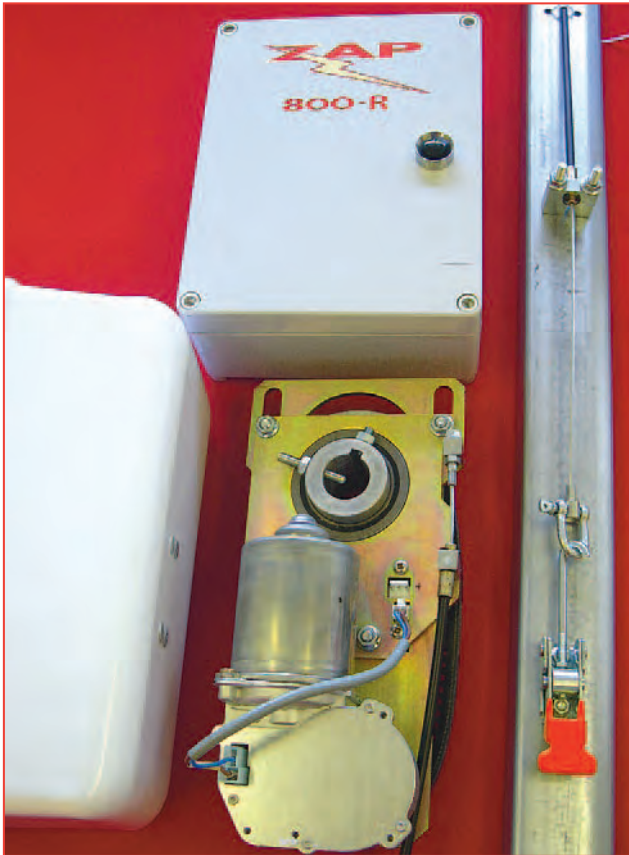

Pic 3

An optional Beeper model 850 may be fitted to sound at the start of each door movement and provide audible feedback during programming and door position calibration.

PREPARATION

Ensure that the door is free to move by hand without any stiffness or misalignment of track sections, which may cause the roller wheels to jump over the track joints. If the door movement is stiff at any point, the roller wheels should be adjusted to allow the door to be moved by hand pressure without any significant force. Any misalignment of track sections should be corrected to ensure the door runs smoothly.

Ensure that the door is reasonably well balanced preferably with the counterbalance spring tension biased slightly open. **(Pic 4)**

Counterbalance springs will weaken over time and the balance can become biased closed. The Zap obstruction sensing system automatically adjusts to



Pic 4

changes in door balance over a period of time. However springs should be checked and adjusted on each service visit at least once per year or 1500 door cycles, whichever is the sooner.

FITTING THE SUPER-DRIVE OPERATOR

The Super-Drive Jackshaft Operator kit includes an anti-torque arm, which prevents the operator rotating and which is bolted to the Super-Drive back plate using the motor cover back spacer provided and secured to a spare hole on the jackshaft bearing plate or onto the doorframe.

It is preferable to lightly screw the torque arm to the bearing plate hole or doorframe securing point before mounting the Motor Cover and Super-Drive. **(Pic 5)**

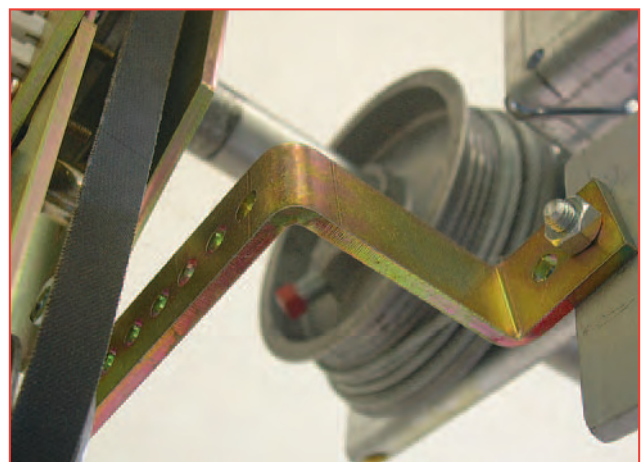

Pic 5

Now slide the Cover back onto the door shaft as shown in the picture. **(Pic 6 overleaf)**



Pic 6

Next slide the Super-Drive assembly onto the door shaft and select a suitable hole in the torque arm to bolt it to the Super-Drive back plate using the spacer bush, which should pass through the lower slot in the Cover back. **(Pic 7)** The Cover back will be secured later. The Torque Arm should be approximately at right angles to the Super-Drive assembly.

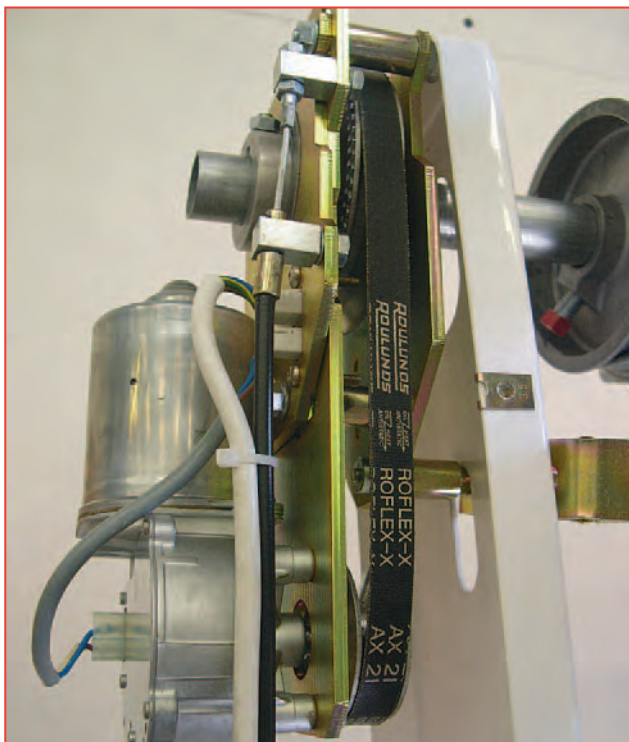

Pic 7

Align the Super-Drive keyway with the door shaft keyway and fit the key supplied with the package. Ensure that the two Allen screws are firmly tight and then tighten the lock nuts. **(Pic 8)**



Pic 8

If there is no keyway one wall of a hollow door shaft should be drilled with a 6mm or 1/4-inch drill bit.

The main Allen screw in the boss of the Driven pulley, should be replaced with the long Allen screw, which is provided in the kit. The long screw should be screwed into the drilled hole in the shaft and tightened against the inside wall of the opposite side of the shaft. The lock nut should then be tightened to secure the screw. **(Pic 9).**



Pic 9

The second Allen screw, set at 90 degrees, should then be tightened and secured with the locknut. Now tighten the torque arm screws **(Pic 10)**

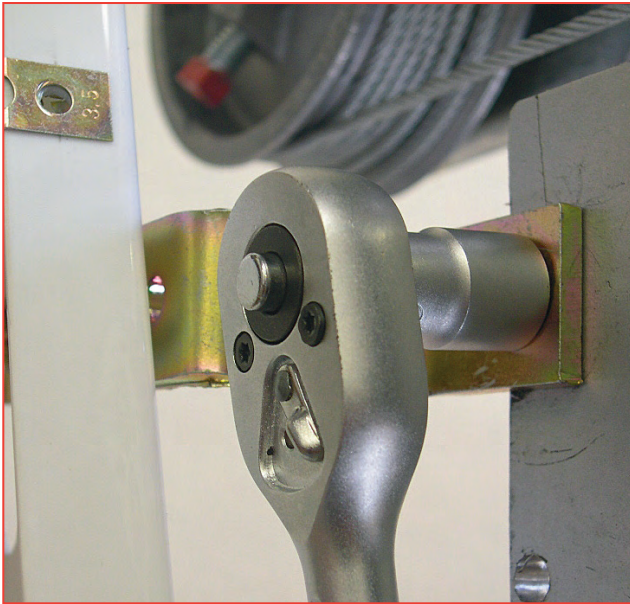

Pic 10

FITTING THE MANUAL OVER-RIDE LEVER MECHANISM

The position of the cable post should be assessed next. The Cable Post, which secures the Bowden cable outer sheath, is fixed to the door track or frame using two M6 flat head screws and flange nuts supplied. Drill two M6 or 1/4 inch holes in the door track or frame in a position at least 25mm or one inch higher than the fully extended position of the outer cable, to allow movement of the upper section of the outer sheath. **(Pic 11)**

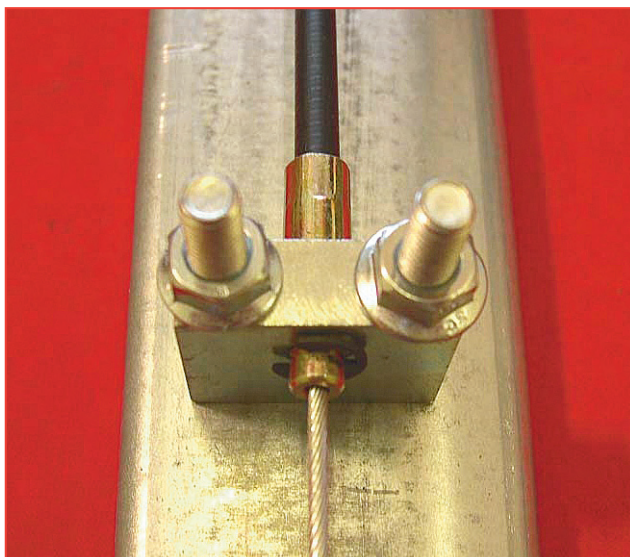

Pic 11

When fitting the Manual Over-Ride lever it is preferable to position the lever relative to the position of the end of the inner cable of the Bowden cable with the lever in the horizontal position.

When fitting the Over-Ride Lever ensure that the lever is horizontal when the cable tension is taken up. It is important that sufficient tension is achieved to ensure that the drive belt does not slip on the motor pulley. The lever should require reasonable hand pressure to lock it into place. The lever hook position is adjustable to allow the Super-Drive V-Belt to be correctly tensioned.

(Pic 12)



Pic 12

Prepare the Manual Over-Ride lever by slackening the lock nut on the screw hook adjuster and unscrew the hook to a position where 75% of the screw thread is exposed on the outside of the boss nut. Slip the lever hook onto the D shackle whilst holding the lever in a position 90 degrees from the vertical with the lever base against the track or frame.

Mark the hole positions for the Manual Over-Ride lever on the door track or frame in a convenient position with the lever held in the horizontal position. Drill two M5 or 7/32nd of an inch size holes. **(Pic 13)**.



Pic 13

Fit the M5 screws provided with the screw head on the inside of the track or doorframe. Fit the M5 nuts.

Secure the hook in the D-shackle of the over-ride cable. **(Pic 14)**



Pic 14

Adjust the Over-Ride Lever hook position to increase, or decrease tension by screwing it in or out of its bush, see **Pic 12**. The hook should be adjusted so that the lever is 90 degrees from the vertical when the cable slack is taken up. **(Pic 15)**

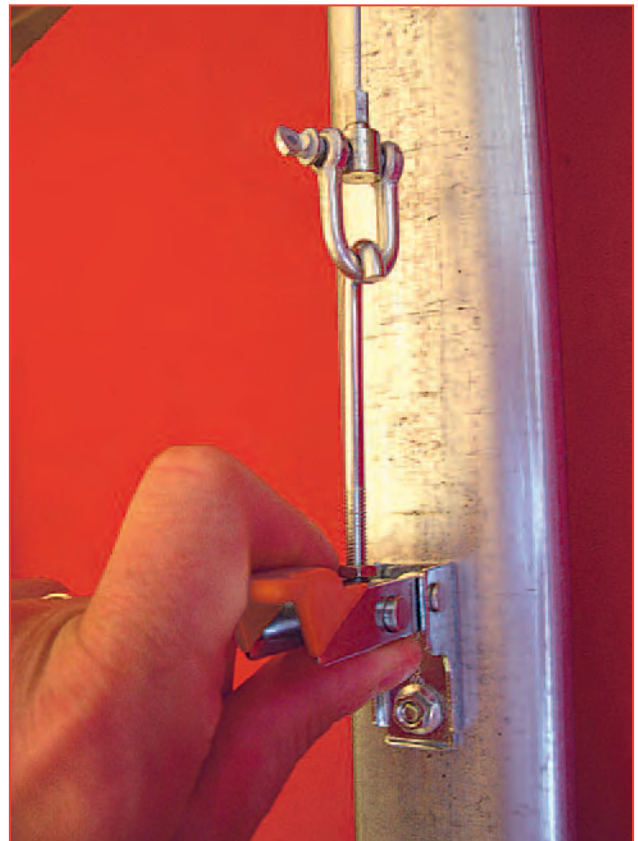

Pic 15

When the lever tension is correct push the lever completely down to tension the V-Belt drive. **(Pic 16)**

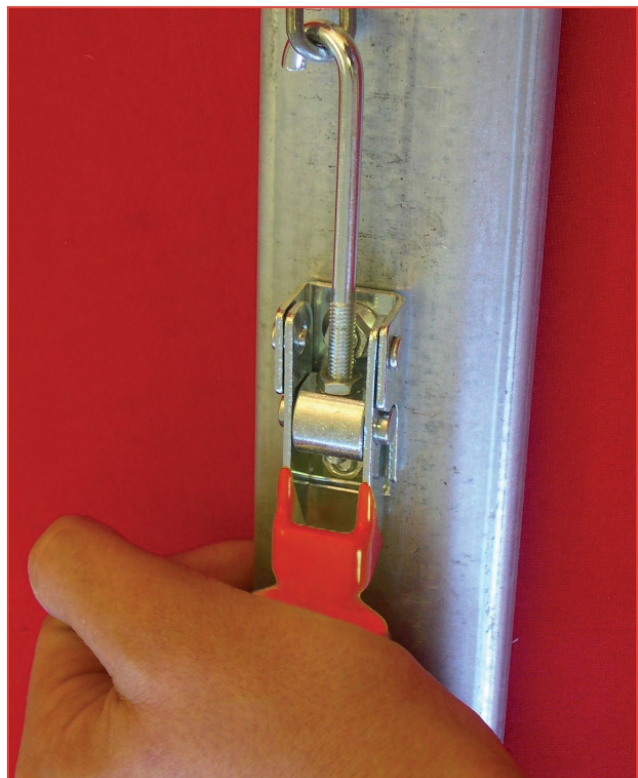

Pic 16

FITTING THE CONTROL UNIT

Check that the control unit voltage, which is shown on the label on the side of the control unit case, is correct for the available single-phase supply voltage.

The control unit model number has a suffix, which relates to the supply voltage.

US is 120 volts

EU is 220 volts

UK is 240 volts

The US/120 volt control unit will operate on a 60 cycle single-phase supply. The EU/220 volt and UK/240 volt control units will operate on a 50 cycle single-phase supply.

The control unit is mounted in a convenient position near and within sight of the door and at least 1.5 metres or 5 feet from the ground, with screws provided passed through the mounting holes in the corner pillars, which are outside of the waterproof gasket. **(Pic 17)**

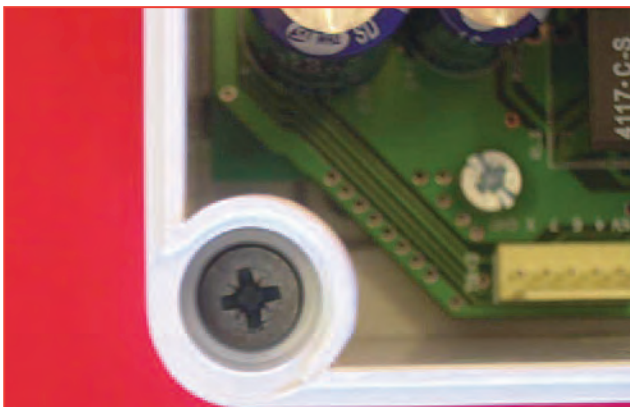

Pic 17

Do not drill holes in the back of the case, as this is liable to allow water ingress and cause damage to the back of the printed circuit board.

Site the control unit so that any conduits are routed to the **BOTTOM** of the case. **DO NOT** drill the top or sides of the case as condensation within the conduit will run down onto the panel and cause operating problems and probable damage.

If the printed circuit board has to be removed from its case, ensure that it is handled with care and not placed on its back on any hard surfaces as this may damage the ceramic surface mount components on the rear of the printed circuit board.

The control unit lid can be temporarily secured to the case side screw positions to prevent it hanging by the cables during the setting up process. **(Pic 18)**



Pic 18

LOW VOLTAGE DC MOTOR WIRING

The Motor Cable is a three-core 3.8 metres (12.5 ft) long harness and is supplied factory fitted to the three way terminal block of the 800-R controller at the bottom right hand side of the circuit board, which is marked "DC MOTOR". **(Pic 19)**

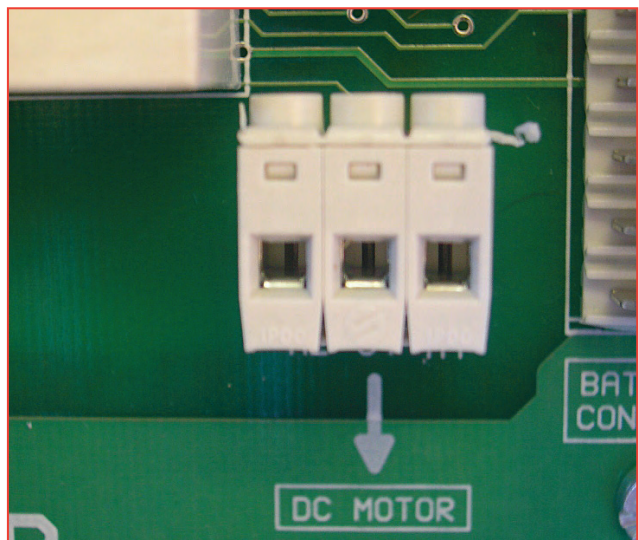

Pic 19

The opposite end should be plugged into the three-way terminal socket on the front plate of the Super-Drive Operator. The motor cable should

be strapped to the Super-Drive Bowden cable with cable ties to allow both cables to seat neatly in the slot in the bottom of the Motor Cover. **(Pic 20)**

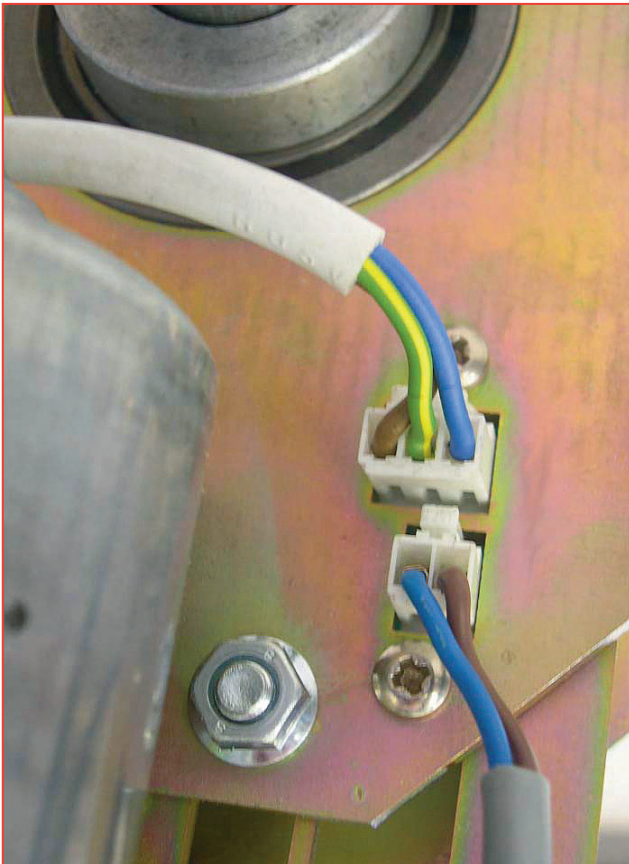

Pic 20

Do not cut or shorten the Motor Cable. Ensure that any unused cable is coiled and secured away from any moving parts, using the cable ties provided.

NOTE THAT ALL TERMINALS ARE PLUG-IN FOR EASE OF WIRING and that all terminal functions are labelled on the panel.

FITTING THE MOTOR COVER KIT

The kit includes a front and back cover section. The cover front has two clips, which clip over the motor barrel.

Position the cover front with the clips resting on the motor barrel. Then firmly push the cover with a hand over the cover clip positions to ensure that the clips are seated in position over the motor barrel. **(Pic 21)**

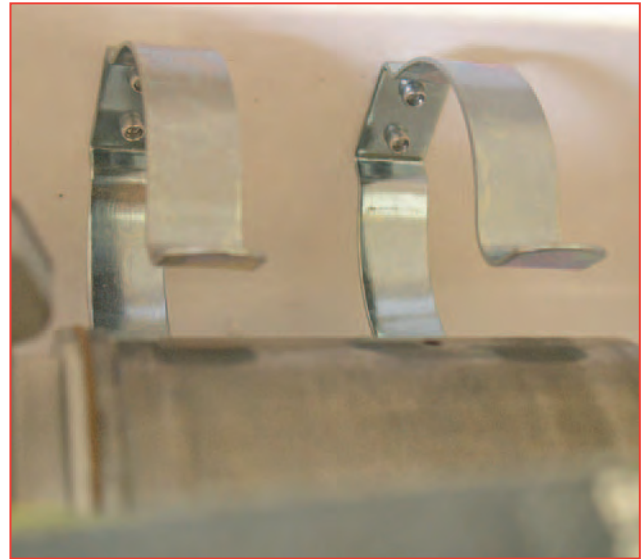

Pic 21

The upper two pegs in the top edge of the cover back are next located in the two holes in the top edge of the cover front. **(Pic 22).**



Pic 22

Seat the cover back in the recess of the front cover and fit the 2 bottom screws and at least one of the side screws provided. **(Pic 23 overleaf)**

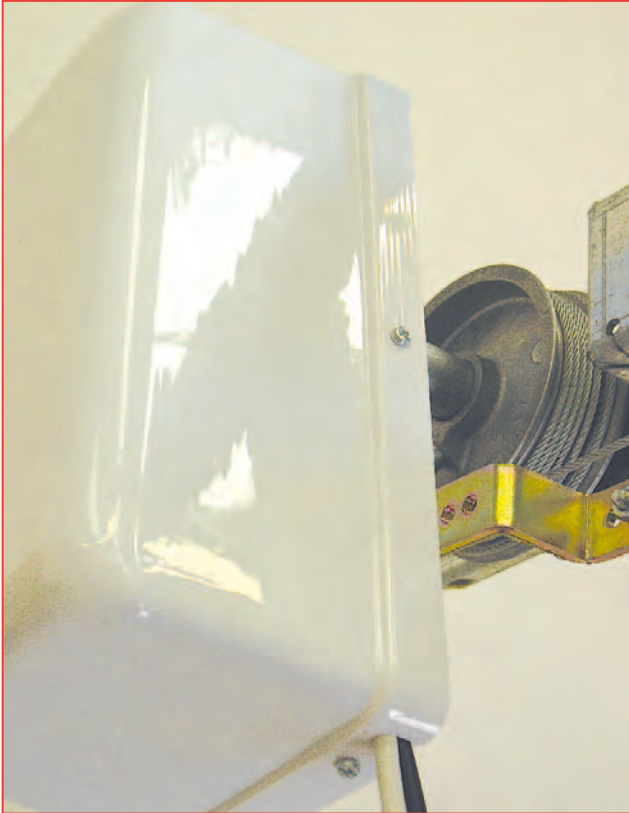

Pic 23

CONNECTING THE MAIN A/C SUPPLY

The Operator should be installed in accordance with local codes and national electric code.

To reduce the risk of electric shock, this equipment has a grounding type plug that has a third (grounding pin). This plug will only fit into a grounding type outlet. If the plug does not fit into the outlet, contact a qualified electrician to install the proper outlet. Do not change the plug in any way.

If it is required to permanently wire the Control unit to the permanent electric wiring in the building then this should be completed by a qualified electrician.

The factory fitted Mains power cord should be secured next. A 1.8 metres / 6 ft main power cable is supplied ready connected to the 800-R controller. It is plugged into the green 3-way connector at the bottom left hand side of the circuit board. (Pic 24)

The power plug can then be located next to a convenient power socket.

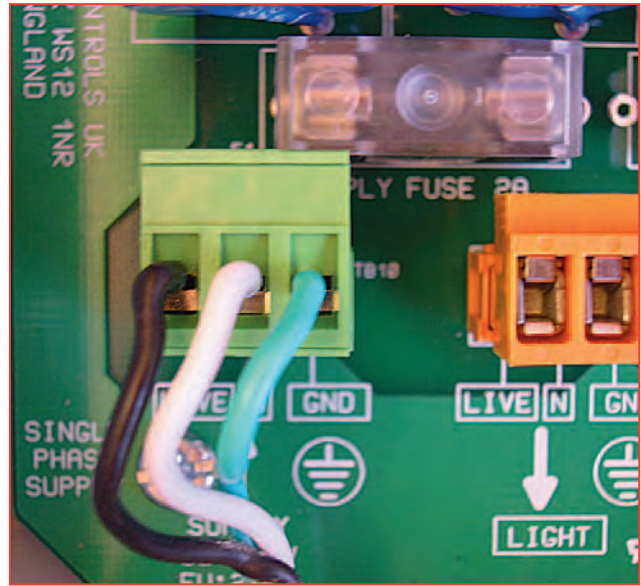

Pic 24

DO NOT PLUG THE POWER PLUG INTO THE SOCKET YET. Please ensure that any unused cable is coiled and secured using cable clips or cable ties provided.

If the Control unit is to be wired permanently into the house wiring circuit, then the main 120 volt (Europe: 220 volt, UK 240 volt) supply lead, with plug attached, should be removed from the Control unit case as follows:

1. Ensure that the main supply plug is disconnected from the line power supply.
2. Unscrew the outer clamp nut of the cable gland through which the main supply cable passes.
3. Unplug the GREEN power connector from the panel socket.
4. Unscrew the three supply wires from the GREEN power connector.
5. Gently pull the cable through the loosened cable gland.
6. Note that two sizes of cable gland entries are provided in the Control unit case, both 3/4" and 7/8". Either entry may be used to provide a conduit entry point for the new supply wiring. Whichever entry point is not used should be secured with a blanking plug of the correct size.

7. The new supply wiring should be terminated to the GREEN connector block. The correct locations for the Live, Neutral and Ground wires are marked on the panel next to the GREEN socket. The new Black (live) wire should be terminated in the left hand terminal. The White (neutral) wire should be terminated in the center terminal and the Green (ground) wire should be terminated in the right hand terminal. **(See Pic 24, previous page)**. Note that alternative wire colors apply to UK and Europe.

If the Lighting output is to be used then the lighting wires should be routed by a qualified electrician to the orange connector at the bottom left hand side of the circuit board. A convenient conduit outlet is provided in the bottom of the case. The lighting circuit wiring should be rated at 3 Amps. **(Pic 25)**

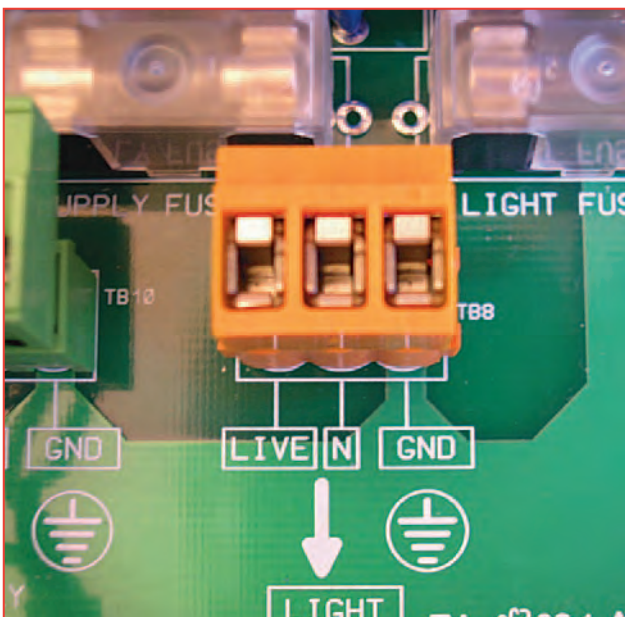

Pic 25

The Lighting circuit may be wired to operate a standard bulkhead light or floodlight of a maximum rating of 250 watts.

If the Lighting output is to be used, then the lighting MODE switch No. 6 should be set as required. The 8-way DIP switch is located at the top right hand side of the printed circuit board panel. **(Pic 26)**

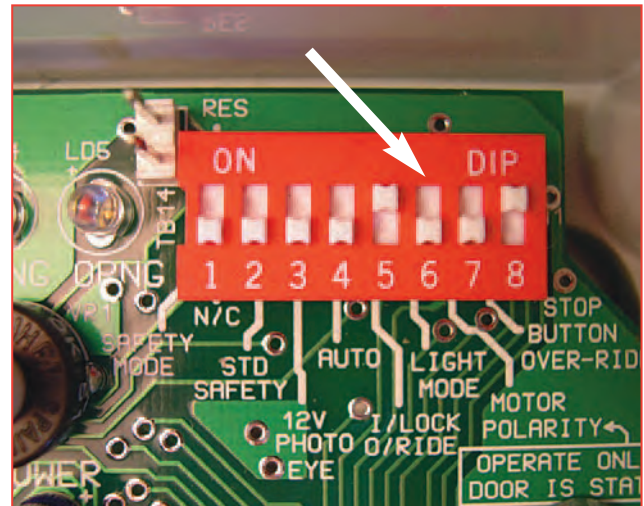

Pic 26

DIP switch No.6 should be set to the OFF position if the light is required to switch on when the door is operated and turn off three minutes from the last operation.

Switch No. 6 should be switched ON if the light is required to switch ON when the door is opened and switch OFF when the door is closed.

If a Remote operation Push Button is to be fitted then it may be wired to operate in parallel with the case mounted button, which is connected to the CYCLE terminals on the printed circuit board. **(Pic 27)**

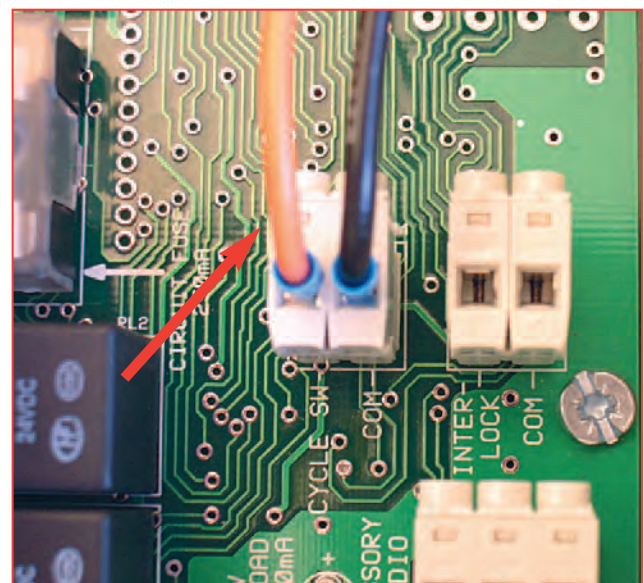

Pic 27

TESTING THE DOOR OPERATION

When the basic wiring is complete the door operation may be tested. It may be helpful to fit an optional Plug-in Beeper module (part No. 850) **(Pic 28)**, which sounds in conjunction with flashes



Pic 28

of the Acknowledge LED. The beeper will sound at the start of each door movement and provides audible feedback during programming and door position calibration. The Beeper is fitted into the white 3- way socket at the upper left hand side of the panel market TB1 – Beeper **(Pic 29)**.

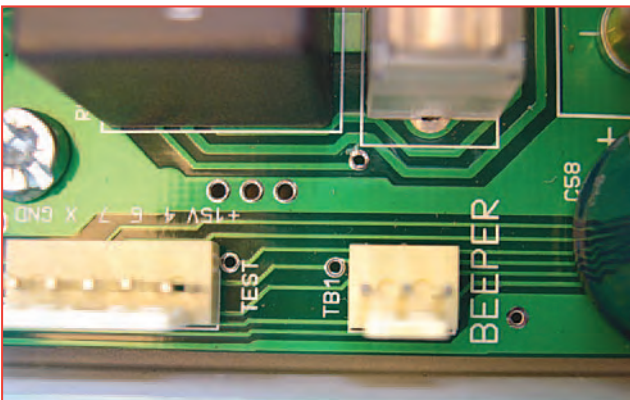

Pic 29

A momentary press of the case lid push button or a remote push button, if fitted, operates the door.

The push button operation is: PRESS TO OPEN – PRESS TO STOP – PRESS TO CLOSE – PRESS TO STOP. The push button may be used to switch on a light, if fitted, when the door is closed and without moving the door, by an extended press of the push button for 2 1/2 seconds until the light illuminates.

Note the factory set positions of each of the DIP switches at the top right hand side of the panel will be: **(Pic 30)**

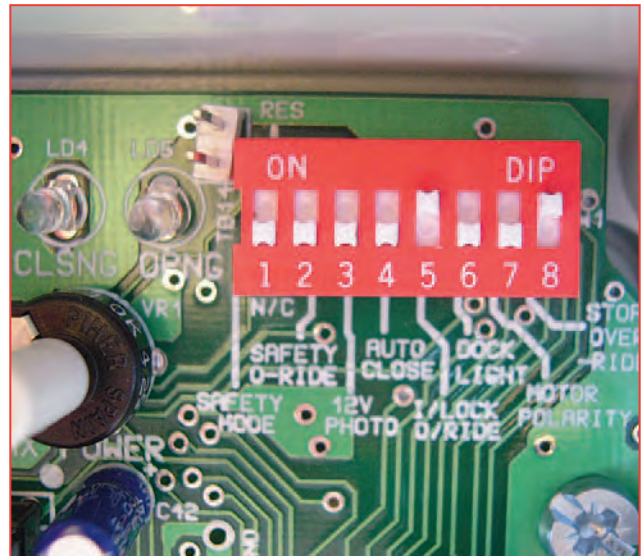

Pic 30

SW1	SAFETY MODE	OFF/N/C
SW2	STANDARD SAFETY	OFF
SW3	12V PHOTO-EYE	OFF
SW4	AUTO-CLOSE	OFF (NOT USED)
SW5	INTERLOCK OVER-RIDE	ON
SW6	LIGHTING MODE	OFF
SW7	MOTOR POLARITY	AS REQUIRED
		(See next paragraph)
SW8	STOP BUTTON OVER-RIDE	ON
		(A separate Stop button is not fitted).

Plug the power cord into the convenient power supply socket and switch on the mains power. Note that the power indicator LD3 is illuminated.

(Pic 31)



Pic 31

DOOR DIRECTION ASSESMENT

The motor direction will depend on which side of the shaft the Operator is mounted.

In order to assess the correct direction of movement of the door first release the Manual Over-Ride Lever and move the door manually to a half open position. Then re-engage the Manual Over-Ride Lever. Momentarily press the Control unit case lid button. The door should initially run in the OPEN direction and is confirmed by the illumination of the OPENING LED at the top right hand side of the control panel (**pic 34**). Now press the case button to stop the motor. Then isolate the main A/C power supply.

If the door runs in the closed direction, isolate the main A/C power supply and set SW7, the Motor Polarity switch to the opposite position. **DO NOT MOVE THE SWITCH WHILST THE MOTOR IS RUNNING.**

DOOR SPEED CHANGE POINT CALIBRATION

Release the Manual Over-Ride Lever and move the door manually to the fully closed position, re-engage the lever and re-connect the mains power supply. The microprocessor reference for the door ground position should now be set. The procedure is referred to as a **CALIBRATION RESET**. This is completed as follows:

1. Press and hold the Reset button. (see **pic 32 and 33**).
2. Press and hold the Program button.
3. Release the Reset button.
4. Wait until the Acknowledge LED flashes (and beeper sounds).
5. Then release the Program button.
6. The Acknowledge LED will flash twice (and the Beeper will sound two beeps) to confirm.

Now momentarily press the control unit push button. Note that the opening LED is illuminated whilst the door is opening. (**pic 34**)

The door will run in fast speed for a few seconds then change to slow speed and stop when it

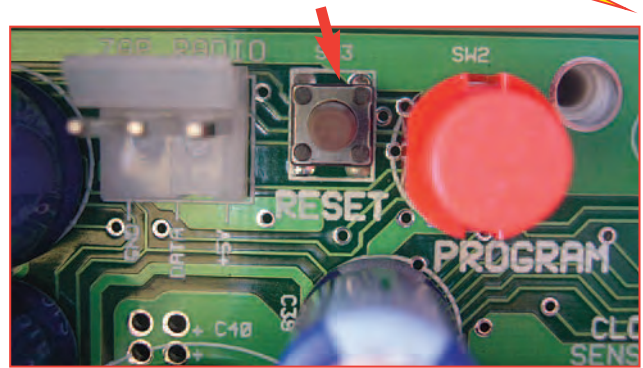

Pic 32

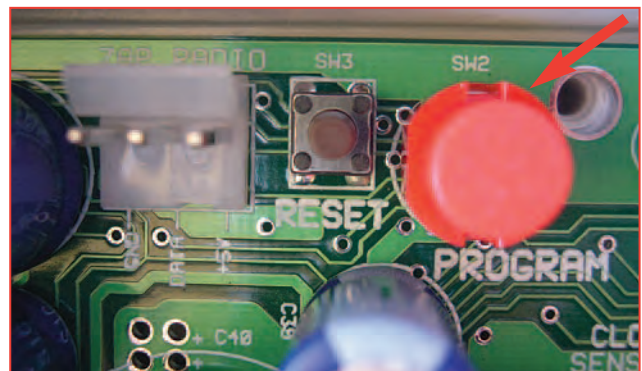

Pic 33

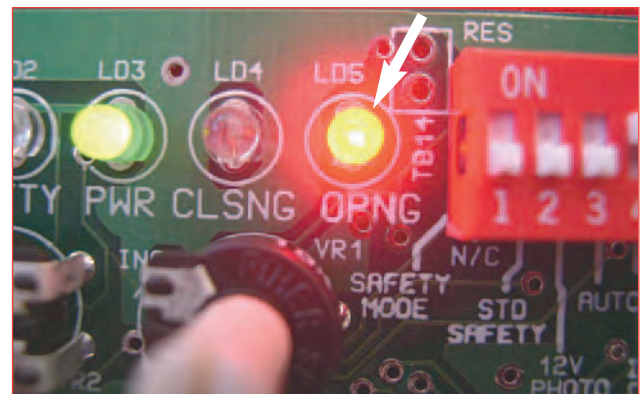

Pic 34

compresses the buffer springs, if fitted, or reaches the fully open position when the counterbalance cables are pulled tight.

The microprocessor now knows the door opening height and will calibrate the speed change points after the next few runs, until they are set a few seconds from each limit of door travel.

Now momentarily press the case push button to run the door in the close direction.

Note that the CLOSING LED, LD4, is illuminated whilst the door is closing. (**Pic 35 overleaf**)



Pic 35

After the door has stopped in the fully closed position, press the OPEN push button again. When the door has stopped in the open position – press the button to close the door. Complete another door open and close cycle and confirm that when the door has correctly calibrated the door stops and remains stationary in the fully closed position.

After the door has calibrated, note that the Acknowledge LED will momentarily flash (and the optional beeper will sound) periodically whilst the door is moving. **(Pic 39 overleaf)**

The door fully closed position is registered after running the door open and closed at least twice. A 1" (25.4mm) decision height is then maintained such that if the door strikes an obstruction higher than 1" (25.4mm) from the ground, it will stop and reopen.

A satisfactory calibration sequence is confirmed if the Acknowledge LED either does not flash or flashes no more than three times after the door has stopped in the closed position.

The Acknowledge LED may flash (and the beeper sound) when the door stops in the fully closed position. If it flashes (and beeps) it indicates that the door fully closed position is higher than the original calibrated ground position. Each flash (or beep) represents 2 1/2 mm or 0.1". For example two flashes (or beeps) indicate that the door position is 5mm or 0.2" higher than the original calibrated ground position. If it produces double flashes (and double beeps) it indicates that the door fully closed position is lower than the original calibrated ground position.

This may occur due to a variation in the compressibility of the weather strip on the bottom of the door after a significant number of door cycles from new, changes in ambient temperature,

a build up of snow and ice or other surface material or subsidence of the ground surface. If the fully closed position varies significantly over a period of time it may be preferable to complete a new CALIBRATION RESET.

If the door is subsequently moved by hand during a power supply failure the speed change points will be automatically re-established following confirmation of the ground position after a complete door cycle in both the open and close directions.

If the door has been moved manually and is operated in the close direction from a part open position, it will stop and reopen from the fully closed position. It will automatically synchronise this calibration with reference to the ground position during the following close cycle, which is confirmed by periodic flashes of the Acknowledge LED (or beeps of the beeper) during the close cycle.

In essence the door will realign to the original ground calibration reference by simply completing a full open and close cycle.

If the roller wheels are too tight or if there is some damage to the door track then the door may stop before it reaches the limit position. If track damage or stiffness is minimal then the motor power may be increased to overcome the restriction by adjusting the **MAXIMUM POWER** preset control slightly clockwise. **(Pic 36)**

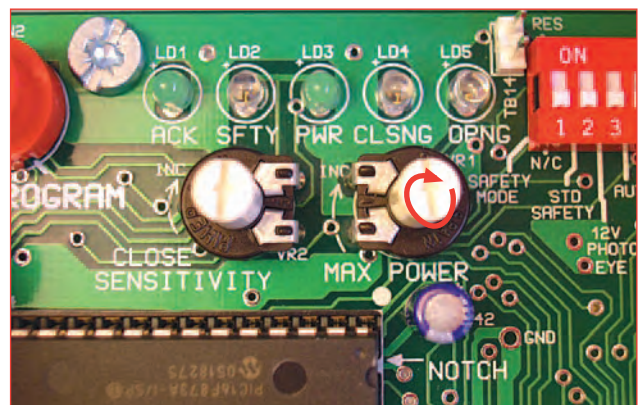

Pic 36

If the control is turned clockwise it will allow an increase in current to flow to the motor and consequently provide extra power to move the door.

The sensitivity of the door detecting and reacting to an obstruction in fast speed in the CLOSE

direction may be adjusted with the CLOSE SENSITIVITY preset. **(Pic 37)**



Pic 37

If it is required to increase the obstruction sensitivity, thus reducing the door edge pressure required to activate the control unit obstruction sensing circuit, which causes the door to stop and re-open during the close fast speed cycle, then the CLOSE SENSITIVITY adjuster should be turned further clockwise. **(Pic 38)**



Pic 38

Note that this will also increase the possibility of the controller reacting to slight abnormalities or minor damage to the track or misalignment of track sections. This may cause fluctuations in the motor current and may be significant enough to result in the door stopping and re-opening. It is therefore important that the smooth movement of the door is tested by releasing the manual over-ride lever and moving the door by hand in both directions.

Both preset controls are factory set to the 12 o'clock positions. Providing the door runs smoothly by hand in both directions it is unlikely that the presets will require adjustment.



Pic 39

If either of the preset controls is adjusted, the compression of the door edge seal will be affected and thus the position of the fully closed door may be different to the calibrated reference. In which case it may be necessary to complete a new Calibration Reset procedure.

SAFETY CIRCUIT WIRING

If the door is to be operated without any supplementary safety devices then the STANDARD SAFETY SWITCH, DIP switch No. 2 and the 12 volt Photo-Eye, DIP switch No. 3 should be set to the OFF position.

If a safety device such as a Standard Photo-Beam (Photo-Eye) or Safety Edge is to be fitted then the STANDARD SAFETY switch, DIP Switch No. 2 should be set to the ON position. This provides a Safety STOP and RE-OPEN control of the door if the safety circuit becomes active whilst the door is closing.

If a Photo-Eye with a Normally Closed relay circuit is fitted, then the relay contact wires are connected to the SAFETY terminals at the top right hand side of the panel. **(Pic 40)**

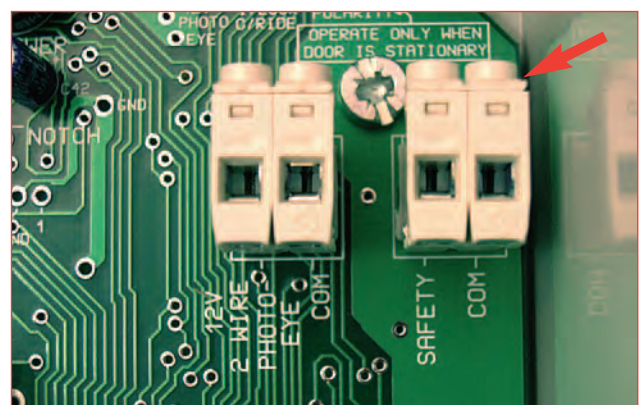

Pic 40

See the wiring diagrams on pages 19 and 20.

If two or more Photo-Eyes, or any other safety devices are fitted then each switching circuit should be wired in series.

A 24-volt Photo-Eye or other accessory may be powered from the 24-volt DC accessory Radio supply terminals at the lower right hand side of the panel. The 24-volt accessory supply may be used to power other accessories such as an accessory radio receiver (non Zap). **(Pic 41)** The maximum current should not exceed 200mA.

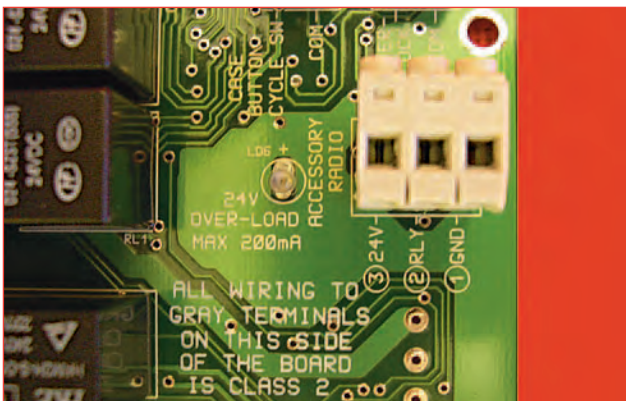

Pic 41

An Over-Load circuit will trip if the accessory load current exceeds 200mA. This is indicated by the illumination of the OVER-LOAD LED. If the over-load does trip then isolate the main power for at least 20 seconds to allow the over-load circuit to reset and disconnect the excessive load.

The range of Zap Photo-Eye units has been designed for universal supply operation. They can be powered from 12 to 240 volts DC or 24 to 240 volts A/C. **(Pic 42)**



Pic 42

12 VOLT TWO WIRE PHOTO-EYE WIRING

A 12 volt two wire Photo-Eye may be wired to the terminals marked at the top of the panel. **(Pic 43)**. DIP switch No. 3 should be set to the ON position. Wiring diagrams for various types of photo-eye units are shown on pages 19 and 20.

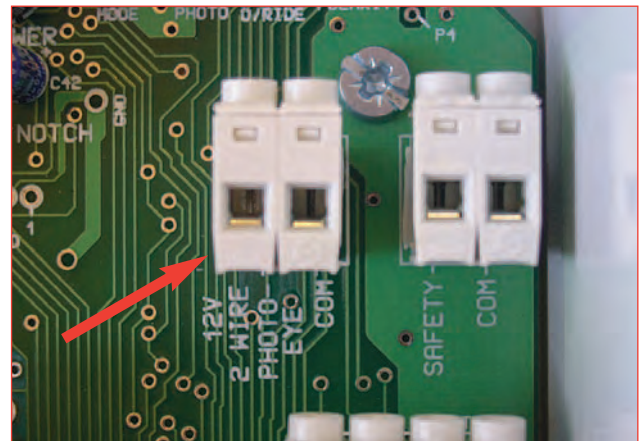

Pic 43

Each time the Safety circuit is activated LED LD2 the SAFETY ACTIVE indicator will illuminate. This is useful when testing the operation of the photo-eye or other safety device without running the door. **(Pic 44)**

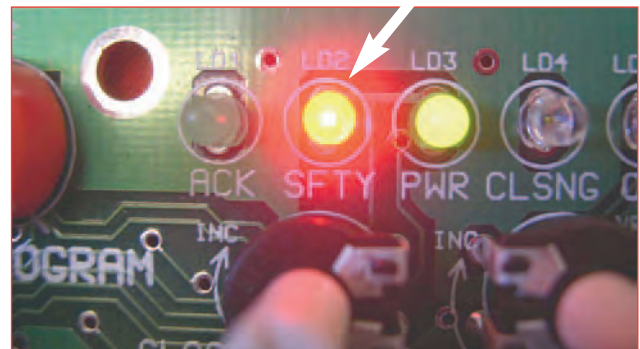

Pic 44

In Europe it is necessary to arrange for a standard safety circuit to be monitored for both an open circuit and a short circuit in which case the circuit must include an 8.2 K resistor at the furthest point in the external circuit. DIP Switch No. 1 should be set to ON which is the position marked RES for resistive.

When the circuit is to be operated as Normally Closed then DIP switch No. 1 should be set to OFF. This position is marked N/C on the panel for Normally Closed.

If the safety circuit is interrupted whilst the door is closing then the door will stop and reopen.

If the safety circuit is interrupted whilst the door is operating with the Auto-Close timer DIP switch No. 4 set to ON then the timer will reset during each interruption of the safety circuit, whilst the door is open. The Auto-Close function is not operational for the North American market.

INTERLOCK CIRCUIT WIRING

A pair of terminals is provided to enable a pass door switch or a key switch to be interlocked to the control unit, to prevent the door opening if the interlock terminals are open circuit. **(Pic 45)**.

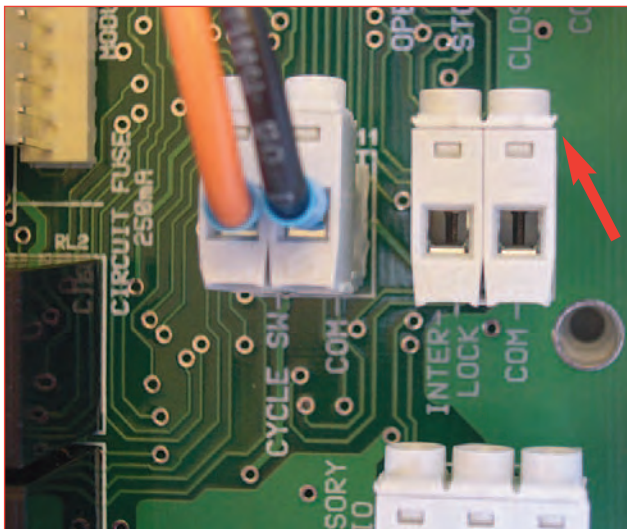

Pic 45

An Inter-Lock Over-ride switch, DIP switch No. 5, is provided if the interlock circuit is not used.

A Slide Lock switch may be fitted and wired to the interlock terminals. However this is not essential as the Control unit will detect the obstruction and stop the door if the slide lock is left in the locked position.

ACCESSORY RADIO RECEIVER WIRING

A non-Zap accessory 3-wire Radio Receiver may be connected to the accessory Radio terminals at the mid right hand side of the panel. The panel is marked to indicate the connections for the 3 radio wires marked 1, 2 and 3. **(Pic 46)**

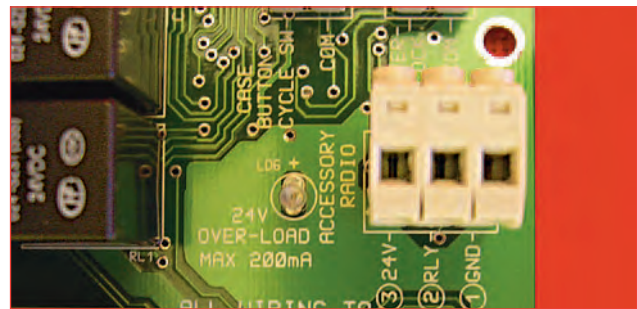

Pic 46

The Radio transmitter button will operate as:
Press to open – Press to stop – Press to close – Press to stop.

The wiring of a non-Zap accessory radio is shown on pages 17 and 18.

A Zap radio receiver model 840 may be fitted in the socket marked "ZAP RADIO" at the top left-hand side of the panel. **(Pic 47)**

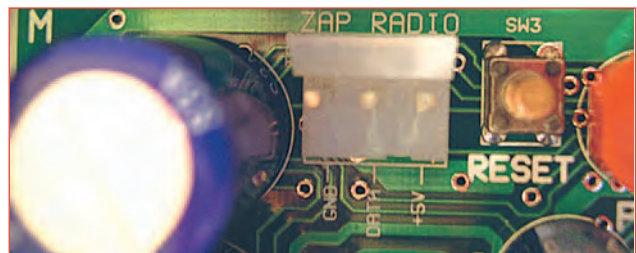

Pic 47

PROGRAMMING

The following functions can be programmed using the Program Button, which is located at the top of the panel. **(Pic 48)**

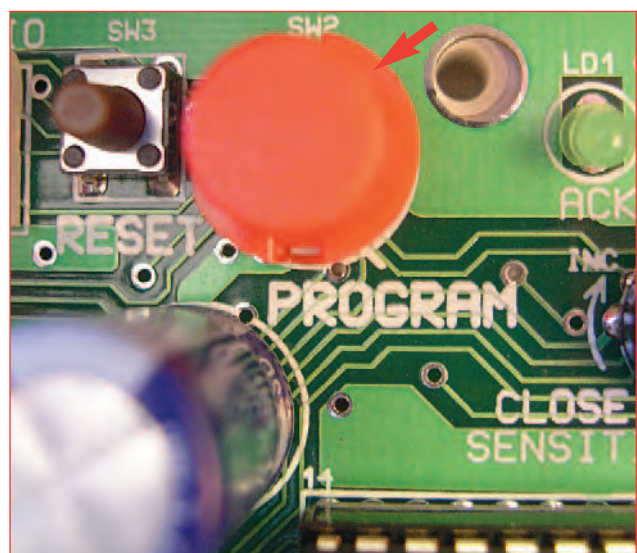

Pic 48

When the program button is pressed and held, a sequence of flashes of the Acknowledge LED follows at 4-second intervals. If a Beeper is fitted then the Beeper will sound with the flashes of the LED.

The first flash or beep indicates the Zap remote control transmitter program mode.

The second flash or beep indicates the Auto-Close timer program mode. (This function is not available for the North American market)

The third flash or beep indicates the Close Delay program mode, which allows an optional Warning device to operate before the door starts to close.

The fourth flash or beep indicates the Zap transmitter code memory erasure mode.

The program button should be released after the appropriate flash or beep to enter the required program mode.

All of the programmed functions are stored in a non-volatile memory, which is retained during a power interruption.

TRANSMITTER CODE PROGRAMMING

Programming of a new transmitter to a non-Zap accessory radio receiver will be covered in the instructions supplied by the manufacturer of the receiver.

A Zap radio receiver model 840 may be fitted in the socket marked "ZAP RADIO" at the top left hand side of the panel. **(Pic 47 page 15)**

To program a Zap transmitter code into memory:

1. First press and hold the required transmitter button.
2. Then press and hold the Program button.
3. Release the program button after the first LED flash or beep.
4. Two flashes or beeps confirm that the code has been stored into memory.
5. Now release the transmitter button.

Three flashes or beeps indicate that no code data was present, in which case repeat the programming sequence.

An optional alternative programming sequence, using the case lid button, is provided for programming additional transmitters as follows:

1. Close the door.
2. Press and hold the new transmitter button.
3. Press and hold the case lid button for at least 2.5 seconds. This will operate the lighting relay without opening the door. A click of the relay will be heard if no light is wired to the control unit. If a Beeper is fitted the beeper will beep when the button is pressed and give a second beep after 2 seconds. Now release the case lid button.
4. The new transmitter code will be read into memory and the lighting relay will operate to flash the light if fitted. Otherwise the relay clicks can be heard. If a beeper is fitted then two beeps will confirm that the new transmitter code has been stored into memory.
5. Release the transmitter button.
6. Now operate the new transmitter within 5 seconds to open the door.
7. If the new transmitter has not been used within 5 seconds it's code will be automatically erased.

Up to 10 transmitter codes can be stored in memory. In which case repeat the programming sequence for each of the new transmitters. (Each transmitter has a different operating code)

To erase all transmitter codes: Press and hold the Program button and release it after the FOURTH flash or beep.

Two flashes or beeps acknowledge that all of the transmitter codes have been erased.

REMOTE CONTROL OF THE LIGHT

When the Light Mode DIP switch No. 6 is set to OFF (3 minute light timer) a remote control transmitter may be used to turn on the light without opening the door by pressing and holding the transmitter button for at least 2 seconds until the light illuminates. The door should not move providing the transmitter signal has been continuous.

Momentary operation of the transmitter for up to one second will cause the door to move and the light to illuminate.

AUTO-CLOSE TIMER PROGRAMMING

This function is not available for the North American market.

The factory set Auto-Close timer delay is 15 seconds.

In order to confirm the operation of the Auto-Close timer first set DIP switch No. 4 to ON. Then press the case push button to open the door. The door will open and re-close after the time delay. The factory preset time delay is 15 seconds.

To change the Auto-Close time delay proceed as follows:

1. Close the door.
2. Set DIP switch No. 4 to the ON position.
3. Press and hold the program button.
4. Release the button after the SECOND flash or beep.
5. Press the OPEN push button.
6. After the door has fully opened and after the required delay press the CLOSE push button. This new delay will now be stored into the memory and retained during any power interruptions.

A sequence of 6 flashes and beeps follow to prompt you to decide if you want the door to

Auto-Close regardless of the door re-opening after striking an obstruction.

It is preferable that the door should re-open and stay open following an obstruction strike. However it may be required for security reasons that the door should Auto-Close after re-opening, after hitting a large build-up of snow and ice in winter, in which case it will make two attempts to close onto the ice. If the snow and ice has not compressed then on the third run it will then stop on the ice.

If the door is required to Auto-Close regardless of such an obstruction then press the close button a second time during the 6 flashes and beeps.

If the CLOSE button is not pressed during the flashes and beeps the controller will default to stay open after an obstruction re-open sequence.

If it is required to change the programmed delay then repeat the programming sequence.

If a Zap Radio Remote Control system is fitted and the Auto-Close function is enabled then operation of the transmitter will only open the door. The door will close after the programmed time delay.

Whilst the door is open, the close delay is reset each time the Zap transmitter is operated and each time a safety circuit or Photo-Eye is activated.

ZAP 800-R CONTROLLER WIRING ACCESSORY RADIO – PULSE OPERATION

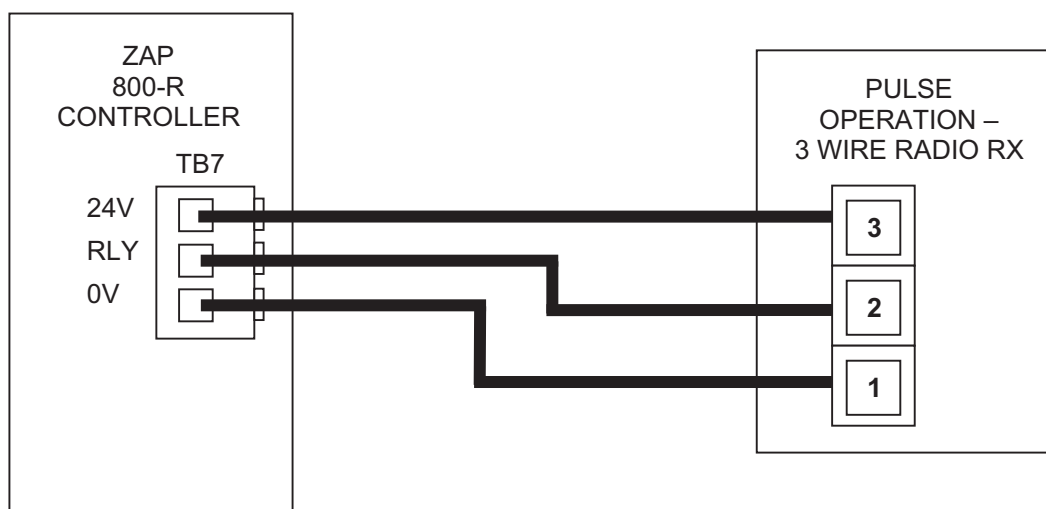

ZAP 800-R CONTROLLER WIRING – PULSE OPERATION WITH LIFT MASTER 412 HM RADIO

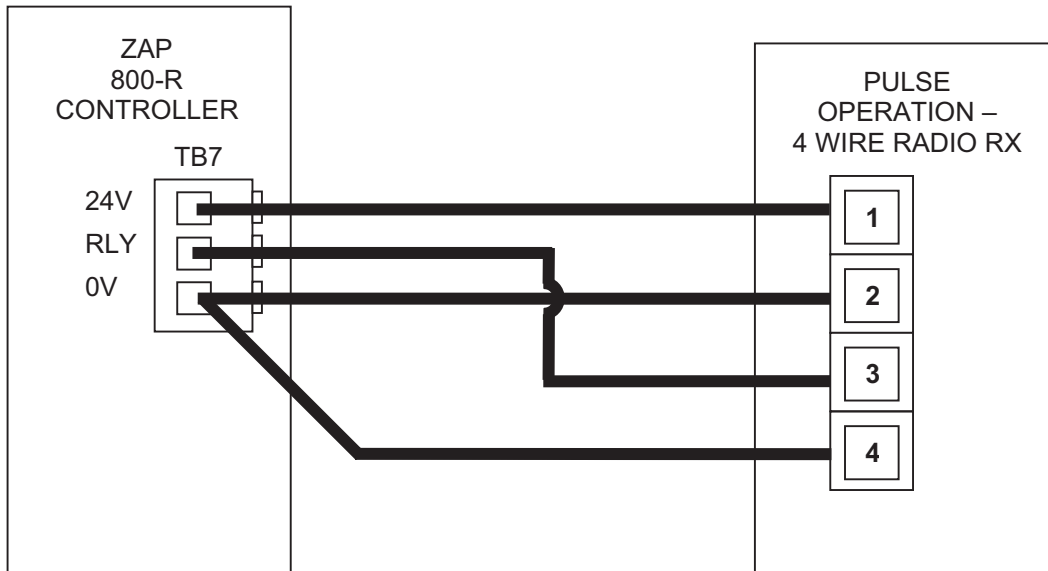

Note: To use the LIFTMASTER 412HM Gate Receiver with the ZAP 800-R Controller you must change the Receiver from Momentary operation to Constant operation. The jumper linking 2 of the 3 Output duration terminals should be transferred to the 2 terminals nearest the outer edge of the panel, which are marked “C” for CONSTANT operation.

Note: if the Radio Receiver does not operate properly then switch the connections on terminal TB7 or refer to the receiver manual for further directions on connections to a DC power supply.



ZAP 800-R – SAFETY WIRING CONNECTIONS – ZAP PHOTO-EYES

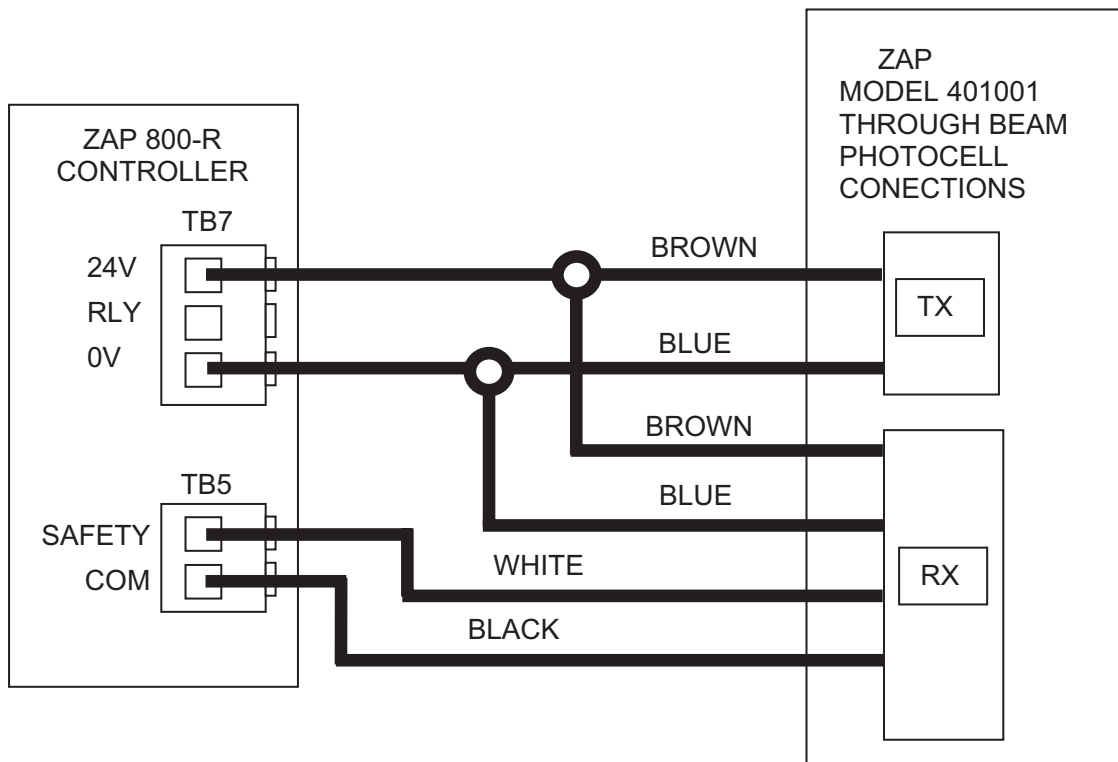
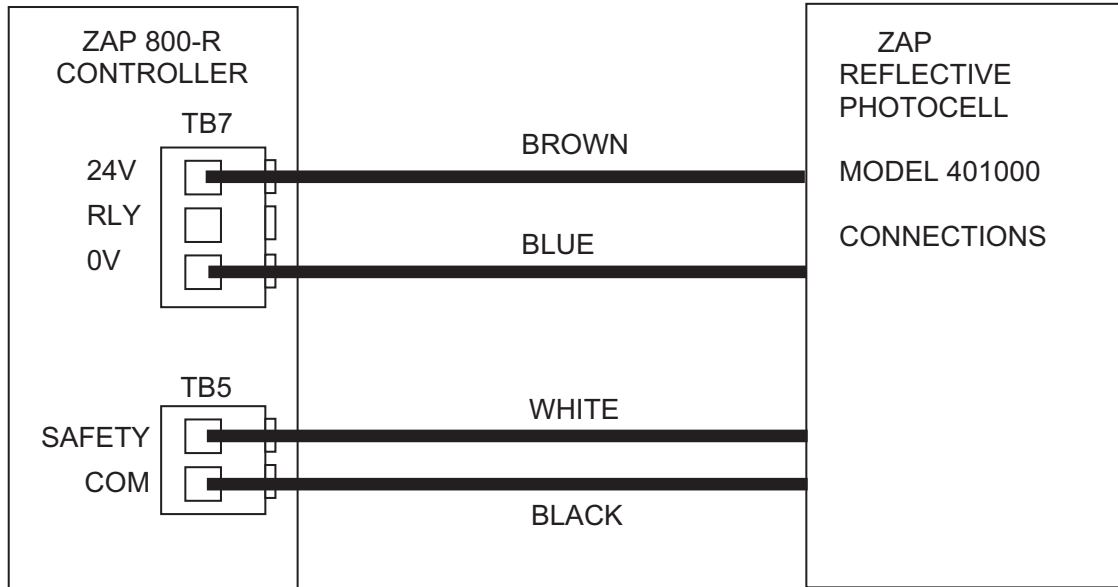

ZAP 800-R – SAFETY WIRING CONNECTIONS – NON-ZAP PHOTO EYES

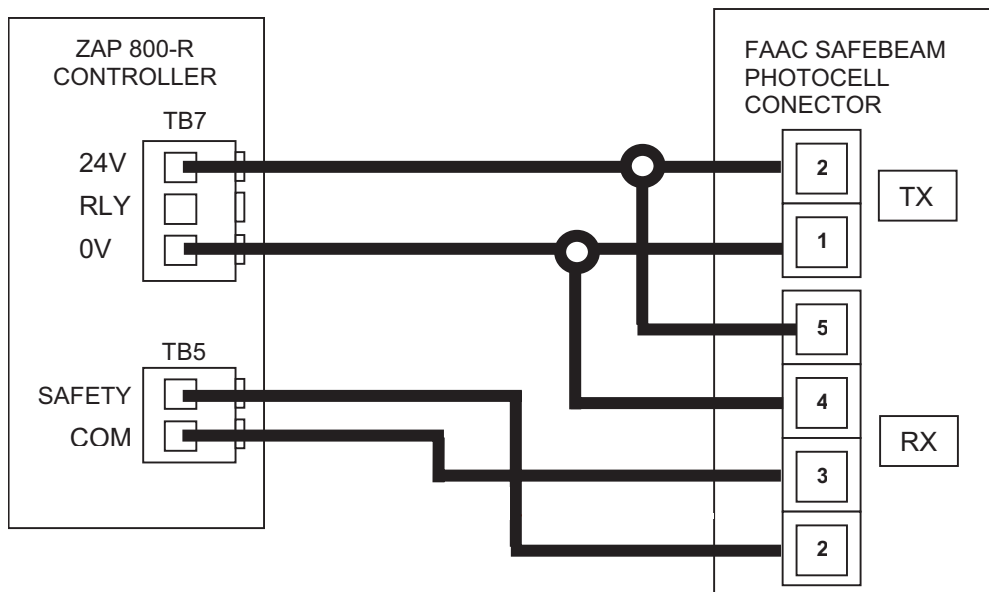
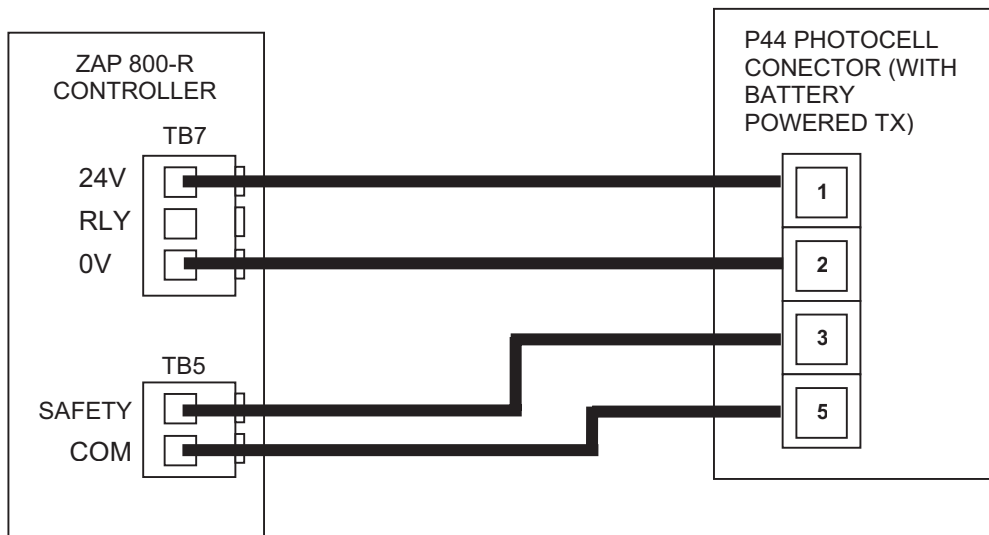
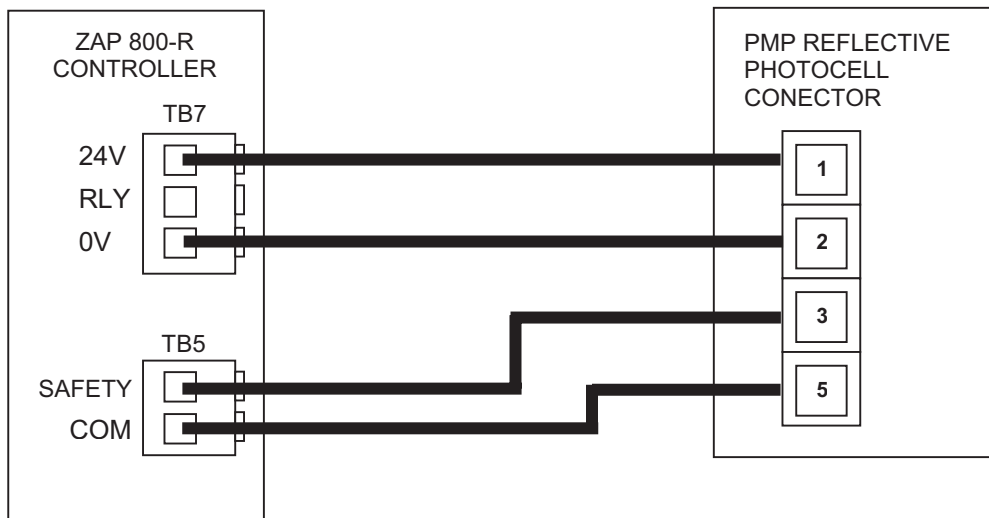

FAULT FINDING GUIDE

FAULT	REASON & REMEDY
1. The door stops just after it has started in the open direction.	<ul style="list-style-type: none">A. The door movement is stiff due to the door running tight against the door frame in the fully closed position. In which case adjust the position of the roller wheel supports to ease the pressure of the door against the frame.B. The door is badly out of balance. In which case re-tension the counterbalance springs.C. The door is near the maximum weight for the operator and the Maximum Motor Current adjuster is set too low. In which case turn the adjuster a further 20 degrees counter-clockwise.
2. The closing door stops and reopens before it contacts the ground.	<ul style="list-style-type: none">A. There is an abnormality in the track, which is causing the roller wheels to jump. This may be due to a misalignment of track sections or a deformity of a damaged section of track. In which case correct the track problem and ensure the door will run smoothly by hand movement with the over-ride lever disengaged.B. The Close Sensitivity adjuster is set too fine. In which case turn the adjuster counter-clockwise by a further 20 degrees.



ZAP CONTROLS UK

100 Waterloo Boulevard
Anglesey Business Park
Cannock
Staffordshire WS12 1NR
United Kingdom

Free Manuals Download Website

<http://myh66.com>

<http://usermanuals.us>

<http://www.somanuals.com>

<http://www.4manuals.cc>

<http://www.manual-lib.com>

<http://www.404manual.com>

<http://www.luxmanual.com>

<http://aubethermostatmanual.com>

Golf course search by state

<http://golfingnear.com>

Email search by domain

<http://emailbydomain.com>

Auto manuals search

<http://auto.somanuals.com>

TV manuals search

<http://tv.somanuals.com>