



Zebra[®] TTP 2100
Kiosk Ticket Printer

Operator Guide



© 2009 ZIH Corp. The copyrights in this manual and the software and/or firmware in the printer described therein are owned by ZIH Corp. and Zebra's licensors. Unauthorized reproduction of this manual or the software and/or firmware in the printer may result in imprisonment of up to one year and fines of up to \$10,000 (17 U.S.C.506). Copyright violators may be subject to civil liability.

This product may contain ZPL[®], ZPL II[®], and ZebraLink[™] programs; Element Energy Equalizer[™] Circuit; E^{3™}; and Monotype Imaging fonts. Software © ZIH Corp. All rights reserved worldwide.

ZebraLink, Element Energy Equalizer, E³ and all product names and numbers are trademarks, and Zebra, the Zebra head graphic, ZPL and ZPL II are registered trademarks of ZIH Corp. All rights reserved worldwide.

All other brand names, product names, or trademarks belong to their respective holders. For additional trademark information, please see "Trademarks" on the product CD.

Proprietary Statement This manual contains proprietary information of Zebra Technologies Corporation and its subsidiaries ("Zebra Technologies"). It is intended solely for the information and use of parties operating and maintaining the equipment described herein. Such proprietary information may not be used, reproduced, or disclosed to any other parties for any other purpose without the express, written permission of Zebra Technologies Corporation.

Product Improvements Continuous improvement of products is a policy of Zebra Technologies Corporation. All specifications and designs are subject to change without notice.

Liability Disclaimer Zebra Technologies Corporation takes steps to ensure that its published Engineering specifications and manuals are correct; however, errors do occur. Zebra Technologies Corporation reserves the right to correct any such errors and disclaims liability resulting therefrom.

Limitation of Liability In no event shall Zebra Technologies Corporation or anyone else involved in the creation, production, or delivery of the accompanying product (including hardware and software) be liable for any damages whatsoever (including, without limitation, consequential damages including loss of business profits, business interruption, or loss of business information) arising out of the use of, the results of use of, or inability to use such product, even if Zebra Technologies Corporation has been advised of the possibility of such damages. Some jurisdictions do not allow the exclusion or limitation of incidental or consequential damages, so the above limitation or exclusion may not apply to you.

Contents



1 • Introduction	5
About this Manual	5
Contacts	6
2 • Product Presentation	7
Presenter	10
Eject Mode	10
Hold Mode	10
Controls	11
Feed Button	11
Power Indicator	12
Status Indicator	12
3 • Installation	13
Installing a Paper Guide	13
Top of Form (TOF) Sensor	16
Selecting Fork (Transmissive) or Reflex (Black Mark) TOF Sensor	16
Positioning the TOF Sensor	16
Calibrating the TOF Sensor	17
Installation Considerations	18
Orientation	19
Quick-Fit Hubs	20
Design Your Own Mounting	21
Electrostatic Discharges and Earth Currents	22
Ambient Light	22
Installing a Paper-low Sensor (Optional)	23
Connecting to the Computer	24
TTP 2110	24
TTP 2130	25

- Connecting the Power 26
- Making a Self-Test Printout 28
 - Customizing the Self-Test Printout 29
- Installing a Printer Driver 30
- 4 • Operation 31**
 - Loading Fanfold Ticket Stock 31
 - Installing a Paper Roll 32
 - Clearing Paper Jams 34



Introduction

About this Manual

This manual will be updated as, from time to time, printer functions and features may be added or amended. You will always find the latest edition on our web site (<http://www.zebra.com>). If you require functions not found in this manual edition, please contact Technical Support for your region or the Zebra partner the printer was purchased from.

Contacts

Technical Support via the Internet is available 24 hours per day, 365 days per year.

Web Site: www.zebra.com

E-mail Back Technical Library:

E-mail address: emb@zebra.com

Subject line: Emailist

Self Service Knowledge Base: www.zebra.com/knowledgebase

Online Case Registration: www.zebra.com/techrequest

Which Department Do You Need?	The Americas	Europe, Middle East, and Africa	Asia Pacific and India
Regional Headquarters	Zebra Technologies Corporation 475 Half Day Road, Suite 500 Lincolnshire, IL 60069 USA T: +1 847 634 6700 Toll-free +1 866 230 9494 F: +1 847 913 8766	Zebra Technologies Europe Limited Dukes Meadow Millboard Road Bourne End Buckinghamshire, SL8 5XF United Kingdom T: +44 (0) 1628 556000 F: +44 (0) 1628 556001	Zebra Technologies Asia Pacific Pte. Ltd. 120 Robinson Road #06-01 Parakou Building Singapore 068913 T: + 65 6858 0722 F: +65 6885 0838
Technical Support For questions on the operation of Zebra equipment and software, please call your distributor. For additional assistance, contact us. <i>Please have your model and serial numbers available.</i>	T: +1 877 ASK ZEBRA (275 9327) F: +1 847 913 2578 Hardware: ts1@zebra.com Software: ts3@zebra.com <i>Kiosk printers:</i> T: +1 866 322 5202 E: kiosksupport@zebra.com	T: +44 (0) 1628 556039 F: +44 (0) 1628 556003 E: Tseurope@zebra.com	T: +65 6858 0722 F: +65 6885 0838 E: China: tschina@zebra.com <i>All other areas:</i> tsasiapacific@zebra.com
Repair Service Department For back-to-base service and repair.	T: +1 877 ASK ZEBRA (275 9327) F: +1 847 821 1797 E: repair@zebra.com To request a repair in the U.S., go to www.zebra.com/repair .	T: +44 (0) 1772 693069 F: +44 (0) 1772 693046 New requests: ukrma@zebra.com Status updates: repairupdate@zebra.com	T: +65 6858 0722 F: +65 6885 0838 E: China: tschina@zebra.com <i>All other areas:</i> tsasiapacific@zebra.com
Technical Training Department For Zebra product training courses.	T: +1 847 793 6868 T: +1 847 793 6864 F: +1 847 913 2578 E: ttamerica@zebra.com	T: +44 (0) 1628 556000 F: +44 (0) 1628 556001 E: Eurtraining@zebra.com	T: + 65 6858 0722 F: +65 6885 0838 E: China: tschina@zebra.com <i>All other areas:</i> tsasiapacific@zebra.com
Inquiry Department For product literature and distributor and dealer information.	T: +1 877 ASK ZEBRA (275 9327) E: inquiry4@zebra.com	T: +44 (0) 1628 556037 F: +44 (0) 1628 556005 E: mseurope@zebra.com	E: China: GCmarketing@zebra.com <i>All other areas:</i> APACChannelmarketing@zebra.com
Customer Service Department (US) Internal Sales Department (UK) For printers, parts, media, and ribbon, please call your distributor or contact us.	T: +1 877 ASK ZEBRA (275 9327) E: clientcare@zebra.com	T: +44 (0) 1628 556032 F: +44 (0) 1628 556001 E: cseurope@zebra.com	T: +65 6858 0722 F: +65 6885 0836 E: China: order-csr@zebra.com <i>All other areas:</i> csasiapacific@zebra.com
Key:	T: Telephone F: Facsimile E: E-mail		



Product Presentation

The TTP 2100 series of ticket printers are available both for kiosk integration and desktop use.



They print on most ticket media from 50 mm to 82.5 mm wide using direct thermal printing. The ticket media can be up to 0.25 mm thick, fanfold, roll, or single cut handfed.

The printers have integrated guillotine cutter, straight presenter, and control board. The print speed is up to 150 mm per second and the eject speed 300 mm/s to ensure high throughput.

The cut can be synchronized with:

- Gaps between tickets, or punched holes
- Black-marks on the non thermal side of the ticket stock
- Foil opacity (for labels on opaque foil backing)
- Ticket corner radius
- Label gaps (for adhesive labels on backing/liner)

You can also print fixed- or variable-length tickets without synchronization. The presenter can be set to eject the ticket into a tray or hold it by the back edge until the customer takes it. The top can easily be opened to give the operator access to the paper path, and printhead, for maintenance purposes.

Figure 1 • Principle of Operation

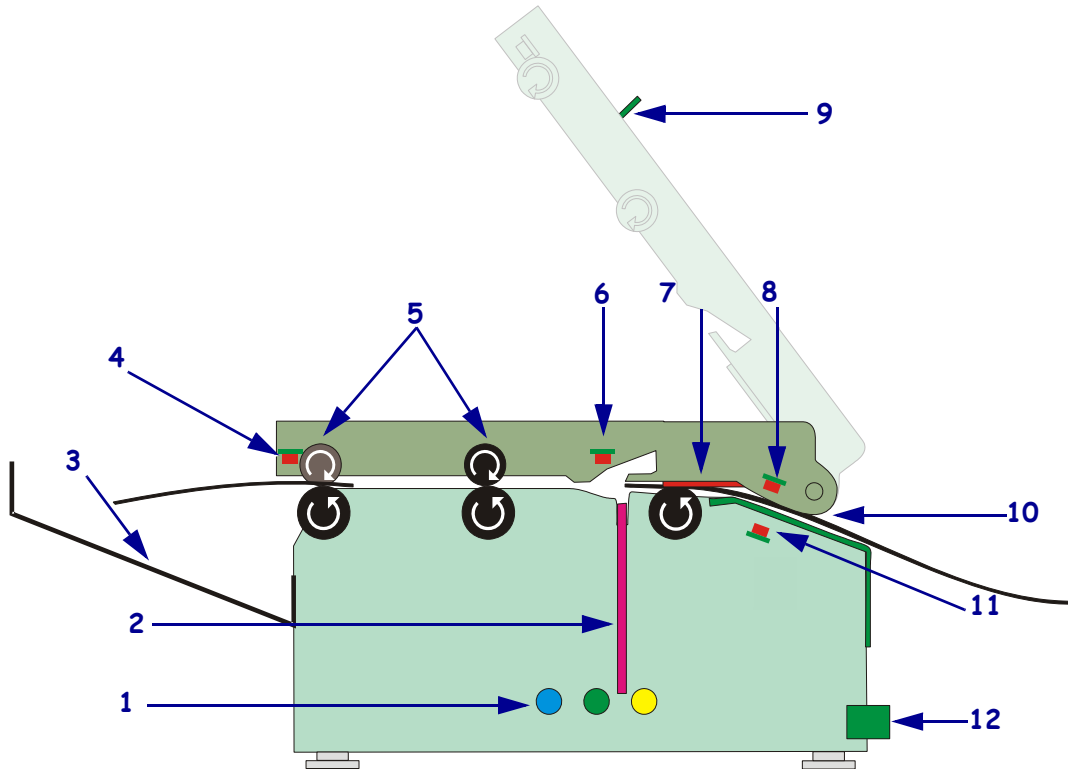

1	Control panel on both sides
2	Cutter
3	Tickets fall (into tray)
4	Ticket sensor (taken/fallen)
5	Straight presenter
6	Ticket load sensor
7	Printhead
8	Upper media sensor (IR light source), adjustable sideways
9	Top release lever
10	Paper entry
11	Lower media sensor (IR light receiver), adjustable sideways
12	Control board

The upper media sensor is an IR light source that illuminates the media. The lower media sensor is an IR light receiver. These sensors must work together to sense media gaps or out-of-media conditions.

The printer is available with two different control boards; the TTP 2110 with serial interface and the TTP 2130 with USB interface.

A printer driver for Microsoft Windows™ is available, and the TTP 2130 interface is compatible with the Plug and Play standard.

The KPL control command language makes it easy to print directly from the ticket software without using a driver. This is especially useful for the serial interface version with its limited data transfer rate.

Presenter

The TTP 2100 does not loop the media. The presenter carries the media through the printer for presentation to the user.

Eject Mode

The ticket is ejected after being cut. The printer is designed so that the ticket always drops down. A sensor is located at the exit of the presenter to ensure that the printer can verify that the ticket drops down. To enable this functionality set “Clear presenter after print” in the driver printing preferences or enable the appropriate parameter setting if using direct print commands.

Hold Mode

When presented, only the very end of the printout is held by the printer so the customer can easily take the printout no matter how long or short it is. If a customer is printing more than one ticket, the printer can detect when the first is taken and automatically print the next and hold that ticket until taken, continuing this process until all tickets have been printed.

Figure 2 • The Presenter

Print and drop

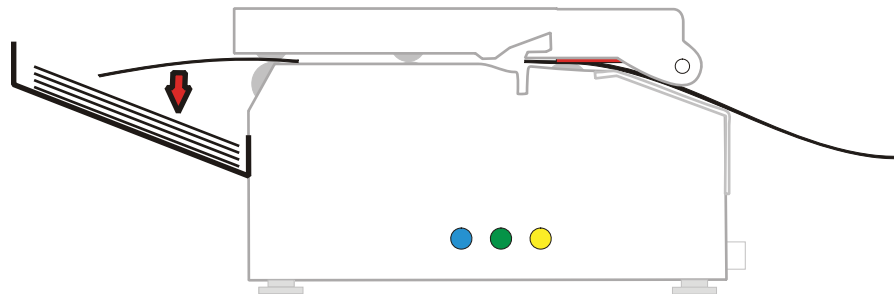

Print and take

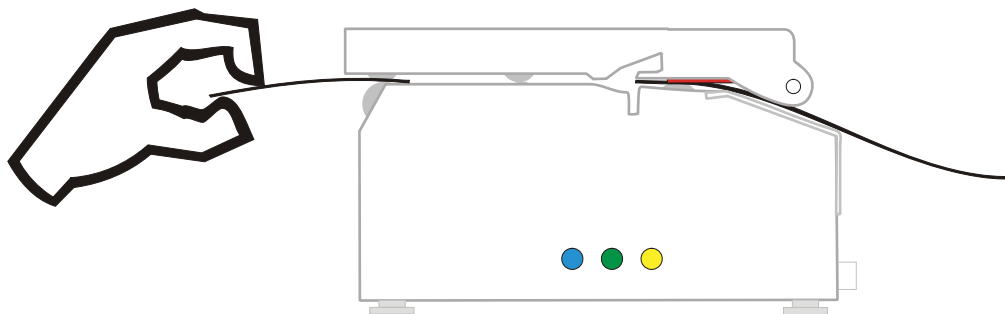

Controls

Figure 3 • Rear View

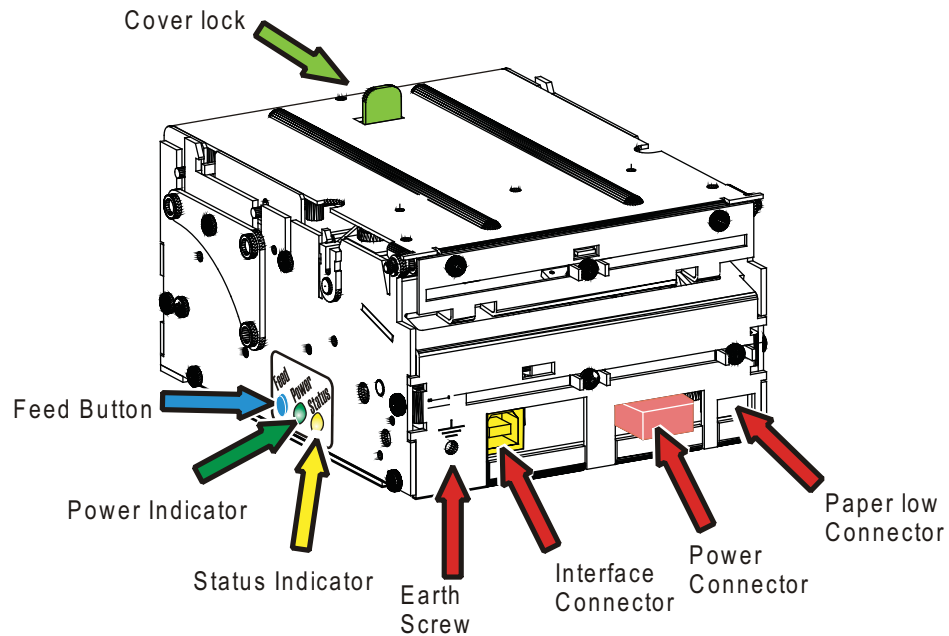

The buttons and indicators are duplicated on both sides of the printer so that they are easily accessible regardless of how the printer is installed.

Feed Button

The **Blue** Feed button has several functions:

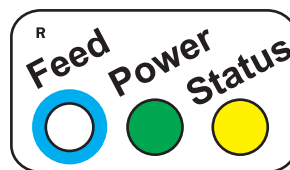

- Press and release will feed, cut, and present a complete page.
- Any data in the print buffer will be printed.
If the buffer is empty the page will be blank.
In black-mark mode, the page will be synchronized with the black-mark.
- Press and hold Feed while turning on the power will print a self-test printout (See [Making a Self-Test Printout on page 28](#)).
- If the printer has firmware version 3.83 or higher, press and hold the Feed button for 3 seconds to print a self-test printout.
- With no paper in the printer, hold the Feed button pressed while closing the printhead to enter TOF mark calibration mode (see [Print Setup on page 86](#)).

Power Indicator

- When the green power indicator is illuminated, a 24V supply is connected to the printer.

Status Indicator

- The status indicator has several functions:
 - **ON constantly** — the printer is operational
 - **Flash, flash, pause, flash, flash** — is the warning-code for paper low. The warning-code is reset automatically when the condition causing it is removed. This behavior is disabled by default but can be enabled by setting parameter 52 (Warning Level) to 1.
 - **Flashes rapidly** — indicates error. Hold down the Feed button and the number of flashes will reflect the *status-code*.

Table 1 • Status Indicator Flash Codes

Number of Flashes	Description
1	Presenter jam, paper cannot be ejected
2	Cutter cannot return to home position
3	Out of paper
4	Printhead lifted
5	Paper did not reach presenter sensor in time
6	Temp error, printhead is above 60°C
7	Paper jam during present
10	TOF mark not found (on media load)
11	TOF mark calibration error
Fast flashes	Checksum error at firmware loading
Steady light	Wrong firmware type
Constantly off	Waiting for paper in TOF mark calibration mode

Status codes are reset:

- When the conditions causing them are removed
- When the printer is power cycled (turned off and then on)
- For all paper jam conditions, after the jam is cleared, lifting and lowering the printhead.

Installation



Installing a Paper Guide

The TTP 2100 printers are delivered without paper guide fitted.

1. Open the printhead by pushing the green printhead open lever backwards and lifting up the printhead. See [Clearing Paper Jams on page 34](#).
2. Insert the T-shaped tabs of the paper guide into the “T”-holes, and press the rear of the guide down and in.
3. Fasten the nut using the 5 mm wrench supplied.
4. Close the printhead.

Figure 4 • Fitting the Paper Guide

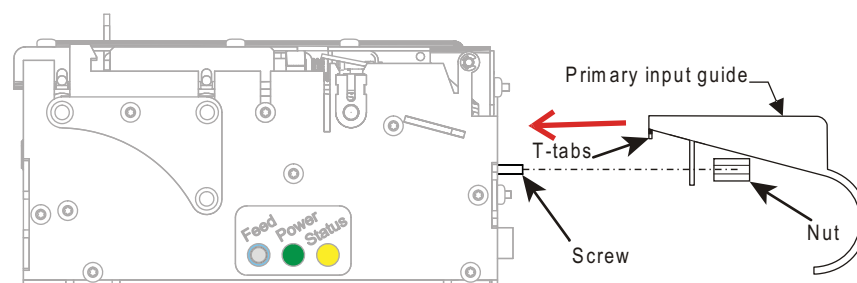

When a guide is fitted, make an auto calibration with the ticket media that you are going to use in the printer. Most ticket medias auto calibrate perfectly, and the printer is ready to use. Should auto calibration fail on your media, set up paper width parameter n48, and sensor selected parameter n63 to reflect your media. Then redo the auto calibration.

5. Start the utility program Zebra Toolbox. This application is available from <http://www.zebra.com>.
6. Select Tools | Parameter Settings.

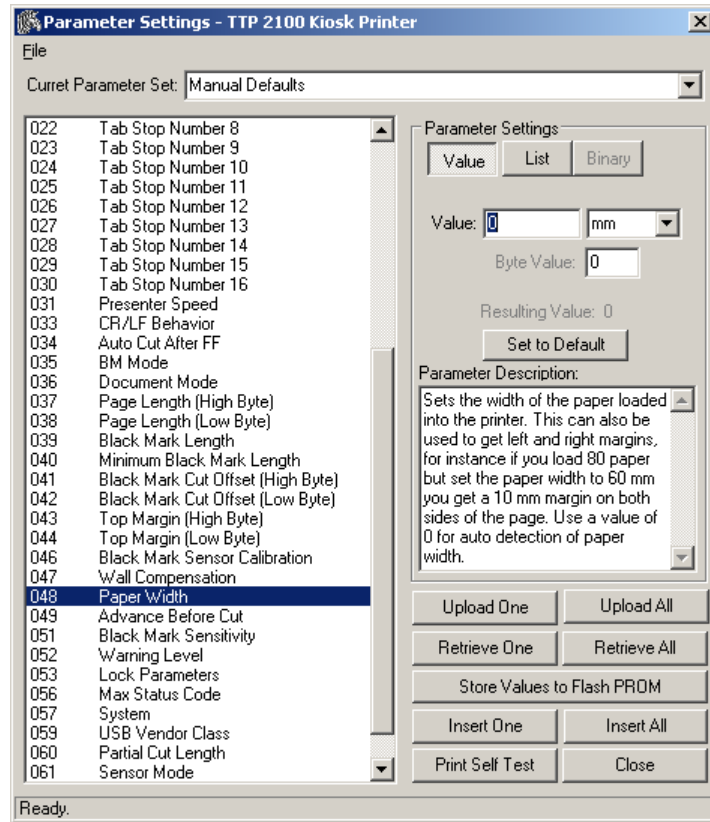

7. Select Parameter 48 (paper width) and enter the value in millimeters of the desired print width.

Paper Width	Setting
82.5 mm	n48=80
80 mm	n48=72
76 mm	n48=70
60 mm	n48=54
54 mm	n48=50
51 mm	n48=46

8. Select Upload One.

9. Select Parameter 63 (BM Sensor) and enter the desired value. Recommended values are:

Value	When Used
0	Auto selects 1 or 4 based on width of media loaded
1	(edge sensor) for ATB tickets without hole in the perforation.
2	(center sensor) for ISO tickets, most other ticket types, and adhesive labels
3	17.5 mm from center sensor
4	12.5 mm from center sensor (for baggage tags according to IATA 740)

10. Select Upload One.

11. Select Store Values to Flash PROM.

12. Wait for the printer to buzz as a confirmation that the new value is stored.

Top of Form (TOF) Sensor

The TTP 2100 has a flexible top of form detection system. When delivered the printer is configured with fork (transmissive) sensor to detect holes/gaps between tickets. The holes/gaps should be in the paper center, 12.5 mm to the right of the center (according to IATA resolution 740) or at the edge of 82.5 mm wide tickets (Boarding cards).

If the TOF mark is at a suitable position, an auto calibration routine will configure everything for you.

You can move the sensor to other positions, force the printer to use a specific sensor, switch to reflex (black mark) sensor for black-mark detection by setting up the parameters in the printer.

Selecting Fork (Transmissive) or Reflex (Black Mark) TOF Sensor

The TTP 2100 can use a fork (transmissive) sensor that looks for holes between tickets, or a reflex (black mark) sensor that looks for black-marks on the back of the ticket stock. Sensor mode is selected with parameter n61, see [Summary of Parameter Settings on page 83](#).

Positioning the TOF Sensor

The sensor board containing the lower media sensor sits on a bracket that can slide left and right in a groove. This bracket is located below the ticket entry. The IR light source (upper media sensor) sits on a similar bracket above the ticket entry. When delivered, the bracket is positioned to the far right. In this position Sensor 1 is at the right side ready to detect the corner radius of Boarding cards, Sensor 2 is at the center of the page, and Sensor 4 is 12.5 mm to the right of the center at the position determined for baggage tags in IATA resolution 740. To configure the printer for other papers that do not fall into any of the three categories, complete the following steps:

1. Loosen the screw holding the sensor 1 ½ turns.
2. Press the screw in with the screwdriver and carefully slide it to the new position making sure the cables to the sensor do not obstruct the movement.
3. Tighten the screw.
4. Move the IR light source (upper media sensor) to the same position, directly above the sensor.



Note • The standard ticket guides have holes for the following sensor positions: Center, Edge, and 12.5 mm from center, and the sensor position must correspond to these holes.

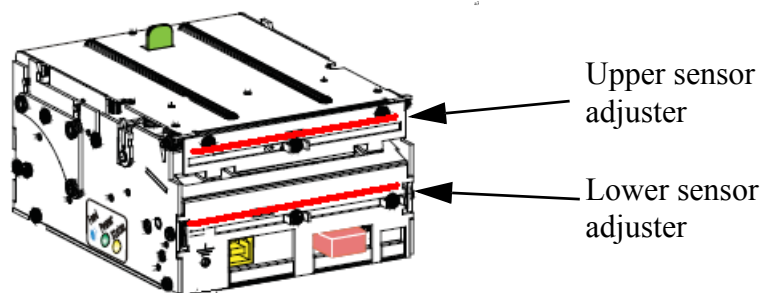

Calibrating the TOF Sensor

1. Open the printhead.
2. Remove ticket stock.
3. Press and hold the Feed button, and then close the printhead (keeping the button pressed all the time).
4. Release the button.
The Status LED should be off.
5. Load ticket stock (slide it into the paper guide and let the printer auto load the paper).



Note • To ensure good calibration conditions, lightly press the ticket stock towards the bottom of the input guide during calibration.

The printer will forward the paper until it finds two TOF marks and then stop and save all TOF-mark parameters.

6. Open the printhead and remove the ticket stock.
7. Close the printhead and feed the tickets in through the paper guide again.
The printer is ready for use.

Repeat this procedure if the calibration fails or if the printer is used with tickets that differ from the original specification.



Note • If you use the Dual guide 01990-400 on your printer, you must calibrate twice (once in the wide paper path and once in the narrow). The printer will choose the appropriate set of parameters based on which paper path contains ticket stock.

Installation Considerations

The TTP 2100 Kiosk is for embedded applications and should be installed in an enclosure such as a self-service kiosk.



Caution • NEVER use screws that go into the printer more than 4 mm! Longer screws will destroy the electronics inside.

The “TTP 2100 Desktop” is a stand alone printer in a housing. The housings can be stacked so two or more printers can reside on top of each other to save space.



Orientation

The TTP 2100 can be installed at any angle. Horizontal is the most common use but vertical with the ticket presenting upwards can be used if you want the ticket to come up from the desk surface. Vertical with the ticket presented downwards can be used if you want to stack many tickets before picking them up.

Figure 5 • Printer Installation Orientation Options

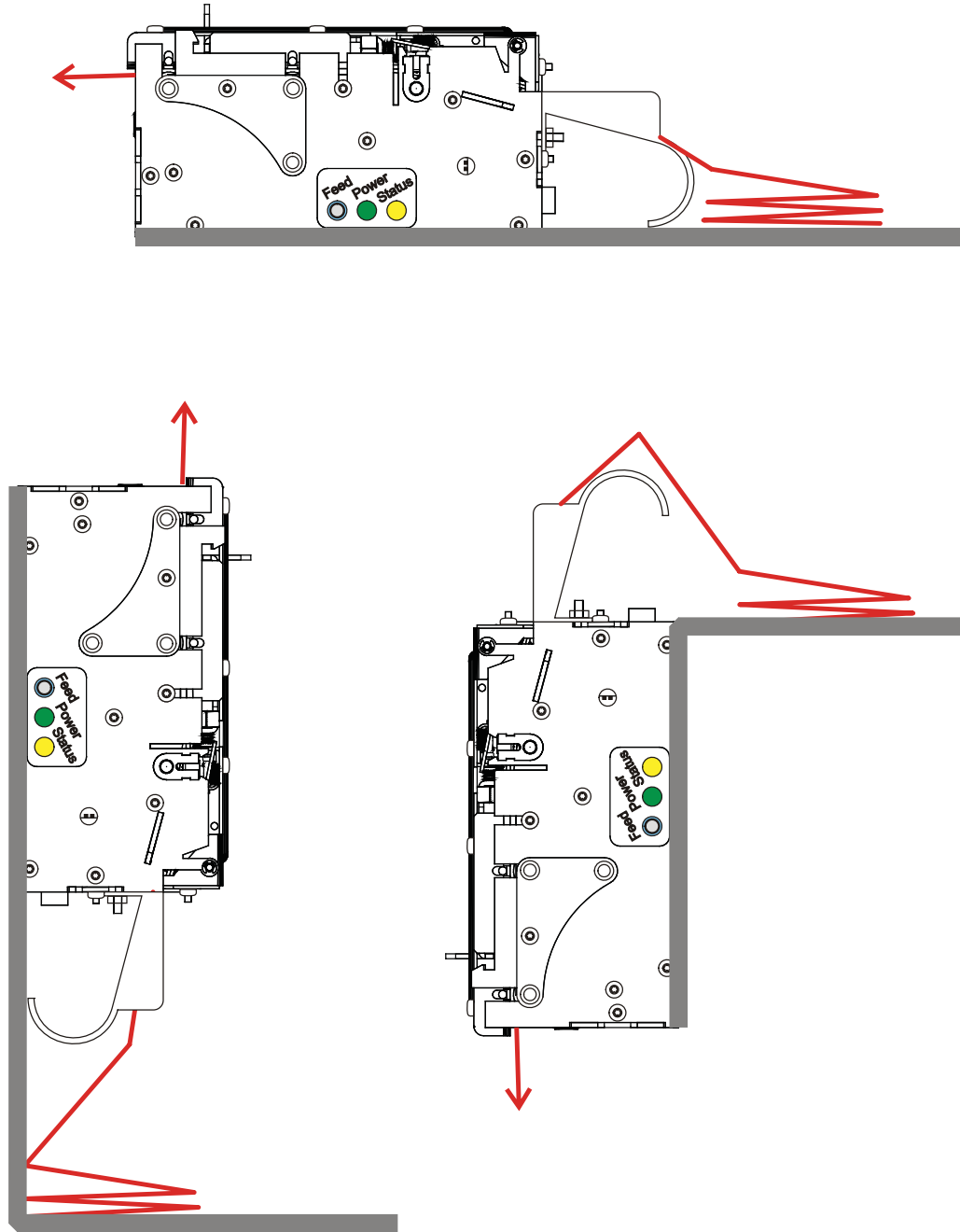

Quick-Fit Hubs

The printers attach to the kiosk in two ways:

- using two screws
- using slides with leaf spring retainers and the quick-fit hubs.

Figure 6 • Front, Bottom View

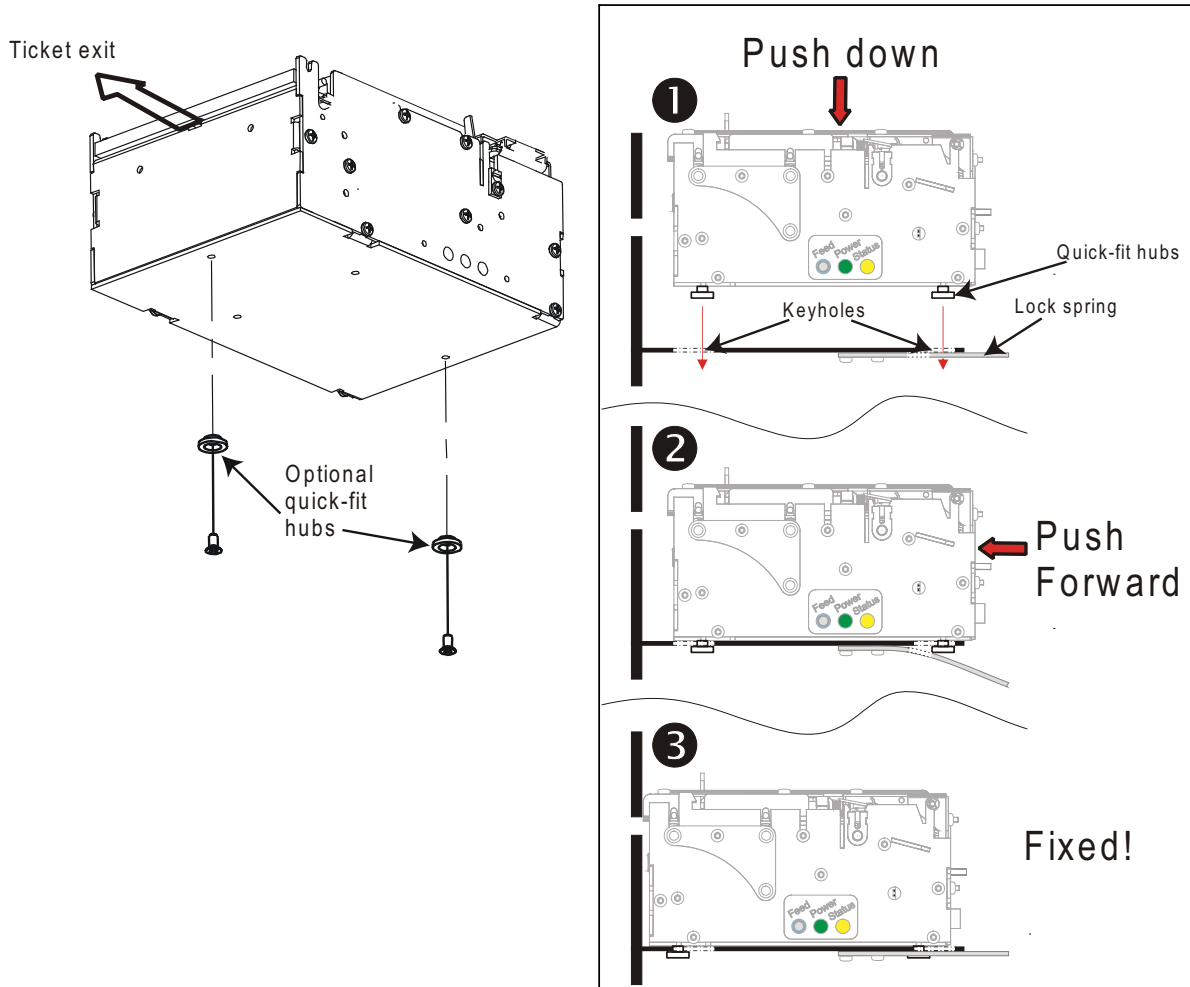

Design Your Own Mounting

The illustration below gives an example of a printer-mounting shelf. See [Dimensions on page 120](#), and the 3D solid models and outline drawings for CAD that are available on <http://www.zebra.com>.

Figure 7 • Example of a Simple Shelf for Fastening a Standard Printer Using Quick-Fit Hubs and a Leaf Spring Retainer (Order No. 01473-000)

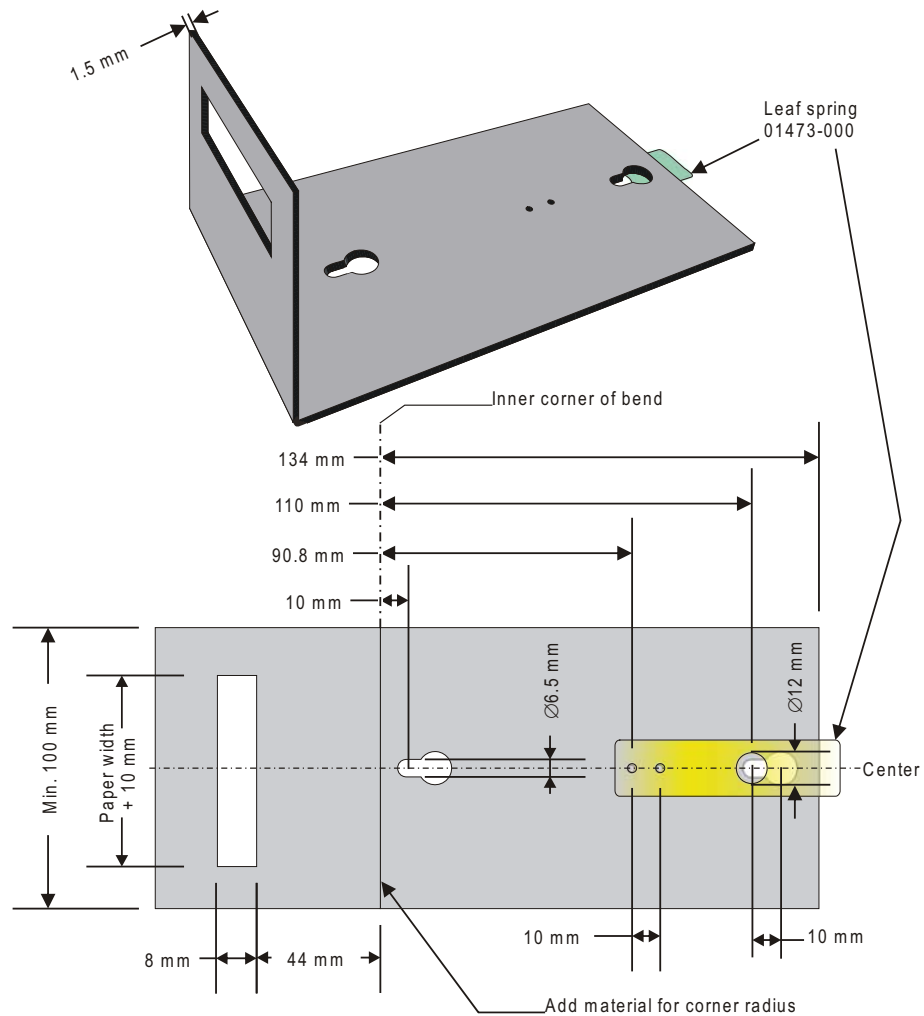

Additional space is required for paper loading and paper jam removal. Consider mounting the printer on a movable platform so that the printer can be maintained outside the printer enclosure.



Note • We recommend you to make the output slot 97 mm wide. This way you will be able to use all paper widths that the TTP 2100 series of printers can handle.



Caution • NEVER use screws that go into the printer more than 4 mm! This will destroy the electronics inside.

Electrostatic Discharges and Earth Currents

Preventing ESD and earth currents from affecting the printer operation requires proper connection of the printer chassis to protective earth through a mounting platform or through a separate earth conductor. A threaded hole for an M4 earth screw is provided on the back of the printer. Use an M4 x 10 screw and two lock washers when fastening the ground cable.

Figure 8 • Location of Earth Grounding Screw

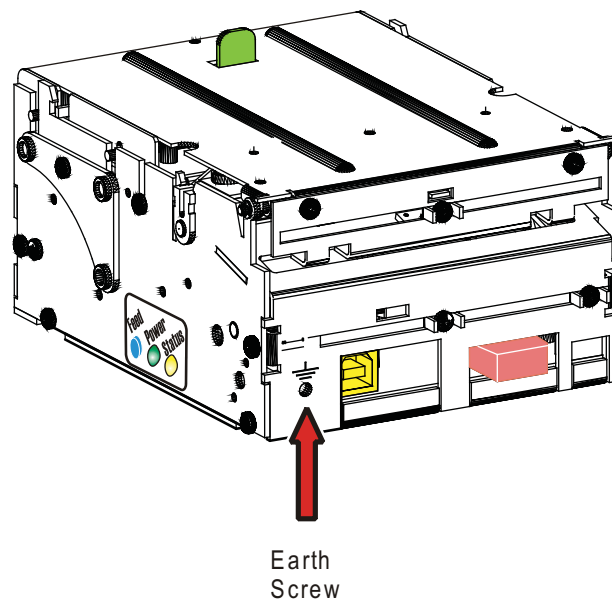

Note • An optional antistatic brush can be fitted to the front of the printer if required.

Ambient Light

There is an optical sensor at the paper exit at the front of the printer.

To ensure proper printer operation, design the kiosk so that it prevents direct sunlight or light from indoor lamps from reaching the sensor through the paper exit.

Installing a Paper-low Sensor (Optional)

A paper-low sensor alerts the system that the media stock level is running low. The paper-low sensor works with paper rolls and fanfold media. The purpose of this sensor is to get an early alert so that you can replace the ticket stock in time in remotely located kiosks.

Roll holders supplied by Zebra can be equipped with paper-low sensors. Attach the sensor and connect the cable to the paper low connector at the back of the printer.

Figure 9 • Paper-low Sensor Connection

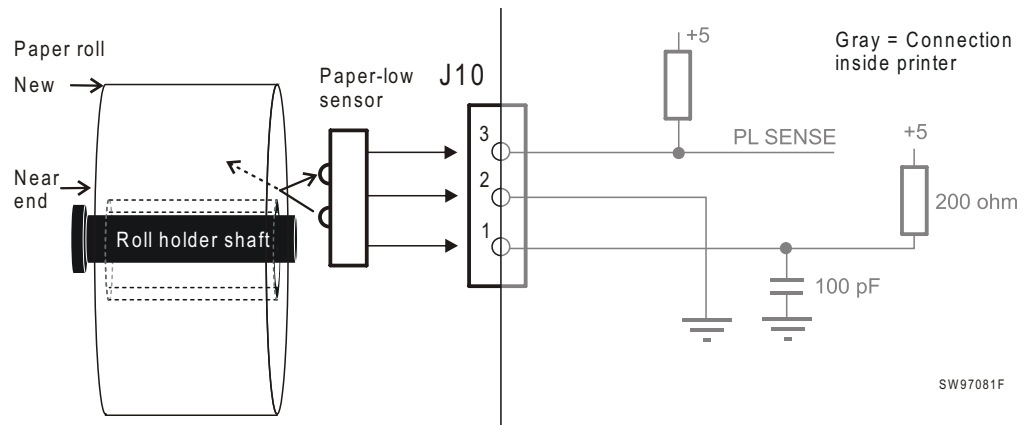
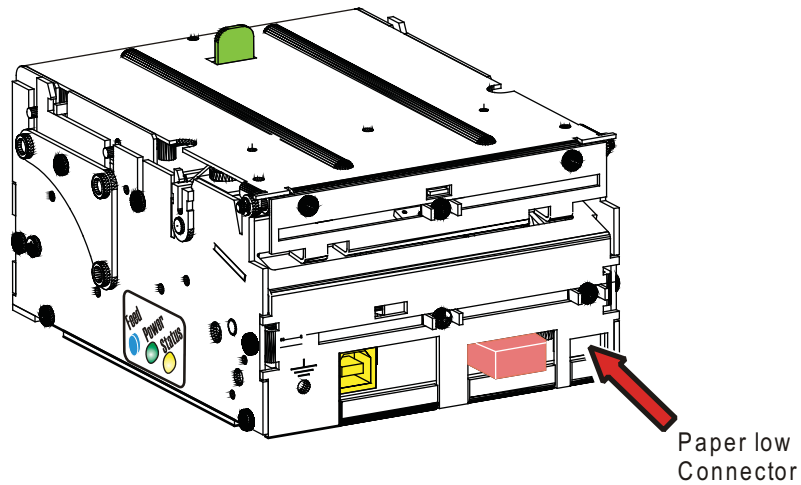
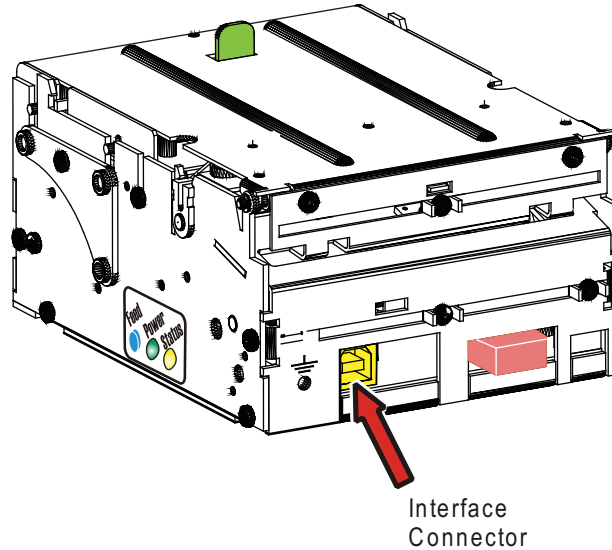

Figure 10 • Location of Paper-low Connector



Connecting to the Computer

Figure 11 • Location of Interface Connector



TTP 2110

Connect a Zebra serial cable, ordering No. 10825-000, between the printer and the computer to be used. We strongly recommend using the Zebra cable because many incompatible cables are available, which may cause communication problems.

Figure 12 • Serial Interface Cable 10825-000.

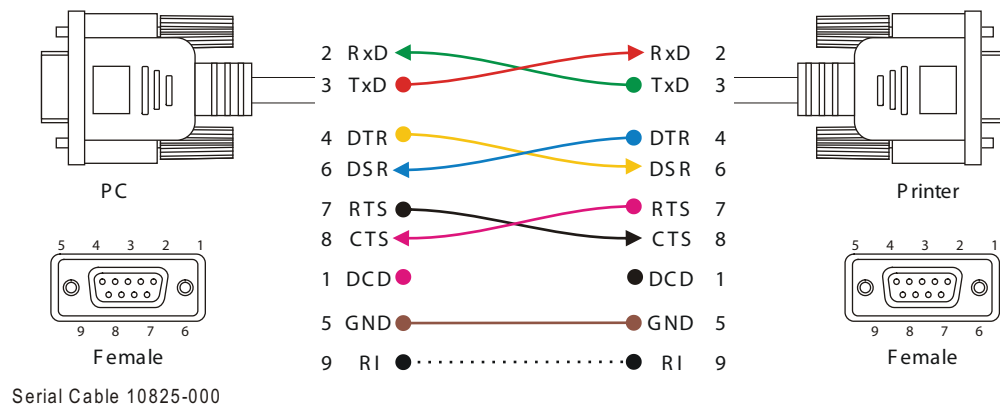

Dotted leads are not connected in the printer. To be able to connect the cable in any direction, make symmetrical cables.

TTP 2130

Connect the printer to the USB port of the computer or the USB hub to be used. USB connectors can be recognized by the following symbol:



The connector on the printer is a 4-pin USB type B connector. See [Table 4, USB Connector \(J13\) Pin Assignment on page 105](#) for pin assignment.

A suitable cable is available from Zebra, part number 105850-028.

Figure 13 • USB Cable with Type A and Type B Connectors

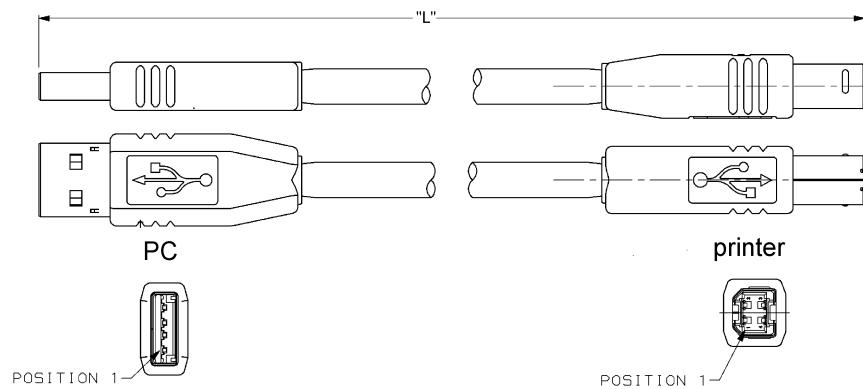

Connecting the Power



Caution • Using a non-Zebra power supply may cause excessive EMC interferences and void the EMC certifications of the printer.



Caution • To avoid electrical shock and printer damage, wiring of a non-Zebra power supply should only be done by qualified service personnel. Use **ONLY** a power supply which meets the following minimum requirements:

- 24 VDC $\pm 5\%$
 - 70W average (2.92A) and 284W peak (11.8A) power supply
-

Figure 14 • Location of Power Connector

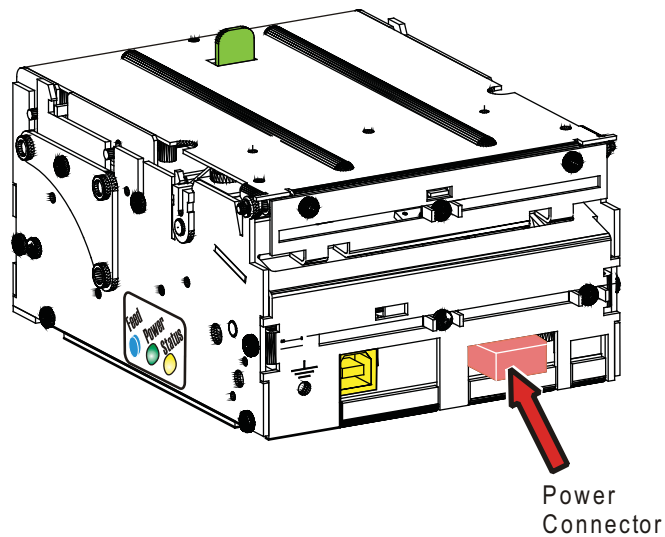

Caution • On power supplies with line voltage selector, make sure it is set to your local line voltage.

Using the appropriate Zebra power supply for TTP 2100 Desktop, or Embedded ([70W Power Supply on page 122](#)):

1. Connect the cable from the power supply the power connector on the back of the printer.
2. Connect the power cable to the line outlet.
3. Turn ON the power.

In kiosk applications you may draw power from a common PSU in the kiosk if the characteristics are suitable. In such a case, cables that fit the connector on the back of the TTP 2100 are available from Zebra. If you make cables of your own, connect the voltages according to the following illustration.



Note • Protective ground and minus output should *not* be interconnected in the power supply.

At the printer end of the cable, use a Tyco Mate-N-Lok connector housing and two contact-sockets.

Figure 15 • Power Connection

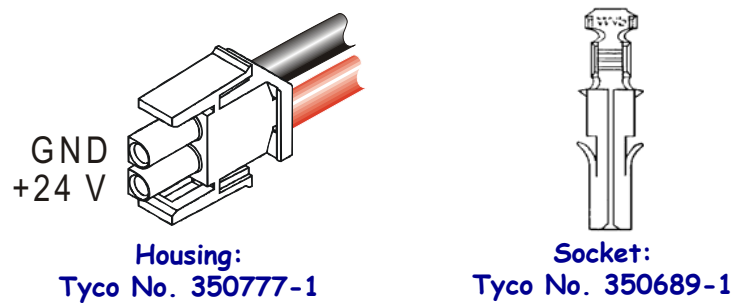

Table 2 • Current Consumption

Mode	58-60 mm paper width	80 – 82.5 mm paper width
Idle	150 mA	150 mA
Standard text printing	0.7 A average	1 A average
All black printing	4 A	6 A

Making a Self-Test Printout

A Self-Test Printout provides a printout showing information specific to the printer, including:

- Firmware version
- Control board (PCA) revision
- Paper width
- Serial number
- Installed fonts and logotypes
- Parameter settings
- Barcode support

To make a Self-Test Printout:

1. Enter Self-Test Mode using one of the following methods:

If...	Then...
the printer has firmware version 3.83 or higher	Press and hold the Feed button for 3 seconds.
the printer has firmware lower than version 3.83	<ol style="list-style-type: none">a. Press and hold the Feed button just after closing the print head.b. See Figure 16. Press and hold the Feed button (1) while turning on the power (2) to the printer.c. Hold down the Feed button until printing starts. Each successive time the Feed button is pressed will produce an additional Self-Test printout until Self-Test Mode is exited.d. Exit Self-Test Mode by power cycling the printer (turning the power off then on again). If the power switch is not easily accessible, open and close the print head.

Figure 16 • Locate the Feed Button and On/Off Switch

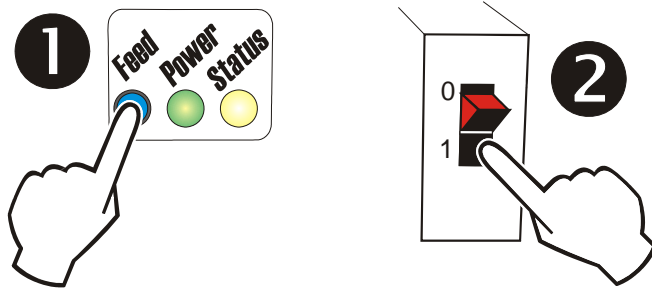

Customizing the Self-Test Printout

The self test printout starts with a text line, and then a Zebra logotype. This logotype is just a printout of logotype No. 0, so if you want to personalize the self test printouts in your installation, delete all logotypes and store your own logotype as No. 0.

See also [Logotypes on page 78](#).

Figure 17 • Logotype No. 0 is Printed on the Self-Test Printout

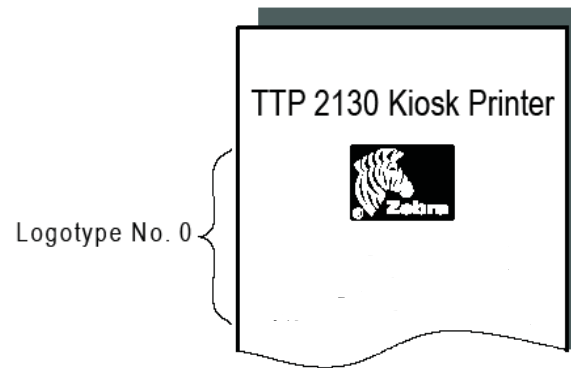

Installing a Printer Driver

A printer driver for Microsoft Windows™ is available on the Zebra web site <http://www.zebra.com>. Please follow the installation instructions that accompany the drivers and refer to the Kiosk Driver Reference Guide, Part Number P1006873-001, available on www.zebra.com for detailed driver information.



Loading Fanfold Ticket Stock

1. Turn the tickets so that the surface to be printed (temperature sensitive side) faces upwards. Put the first ticket on the input guide and slide it up the guide into the printer.
2. The printer will feed the paper, locate the edge and reverse to printing position.
3. When ready, the yellow status led will be ON indicating that the printer is ready to be used.



Note • Remember that the thermal coating should be upwards and black-marks (if used) should face down. The printer will automatically load the tickets when the sensors detect a ticket is loaded.

Figure 18 • Loading Ticket Stock

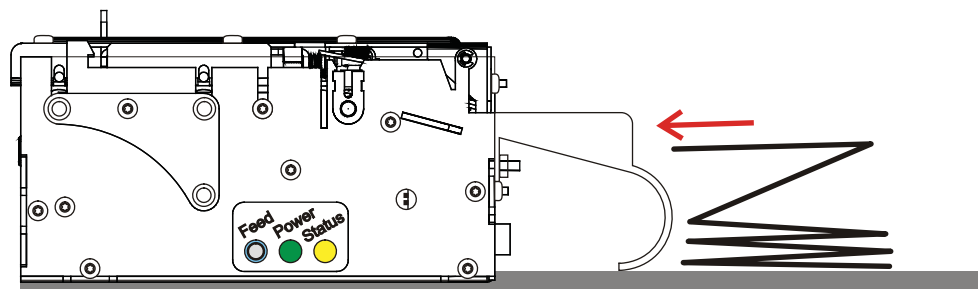

Installing a Paper Roll

1. Turn the new paper roll as shown. The paper should be inserted into the printer with the temperature-sensitive side up so that the paper leaves the roll from the top.

Figure 19 • Installing a Paper Roll

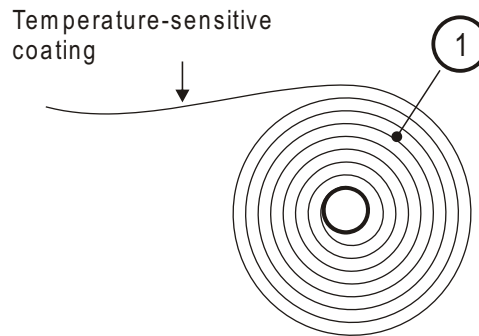

SW96074C

2. Tear off a full turn of the paper from the new paper roll.



Caution • This is important since the outer end of the paper is usually fixed to the roll with some type of glue or self-adhesive substance that might otherwise cause paper jam or even printhead damage.

Figure 20 • Remove Outer Layer of Paper Roll

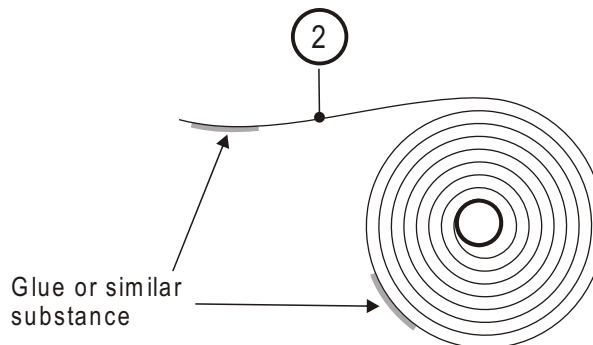

SW96075C

3. Make sure the printer is turned ON.
4. Insert the ticket stock through the paper entry opening at the back of the printer.



Note • The ticket sensor is at the center of the print width. If the ticket edge is torn off in such a way that the sensor does not see it, auto load will not be triggered. If so, reshape the edge so that the sensor sees the ticket stock.

5. Press the Feed button so that the printer feeds, cuts, and ejects a page. This ensures that the first ticket printed will have a straight edge.

Figure 21 • Example of Bad Page Edges

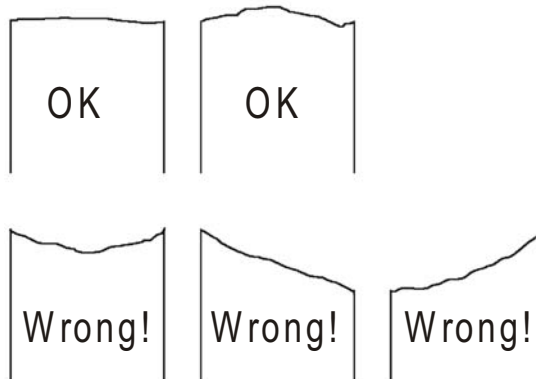

Clearing Paper Jams

Should a paper jam occur, follow the procedure below:

1. Open the printer lid.
 - a. Press the green release lever toward the rear of the printer.
 - b. Lift the lid.

Figure 22 • Opening the Lid

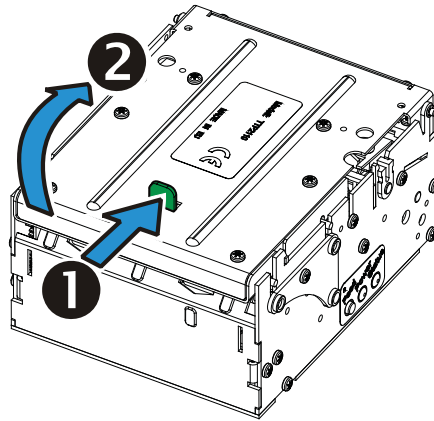

2. Remove all jammed paper, make sure the paper path is clear, and close the lid.

Figure 23 • Remove Paper Trash

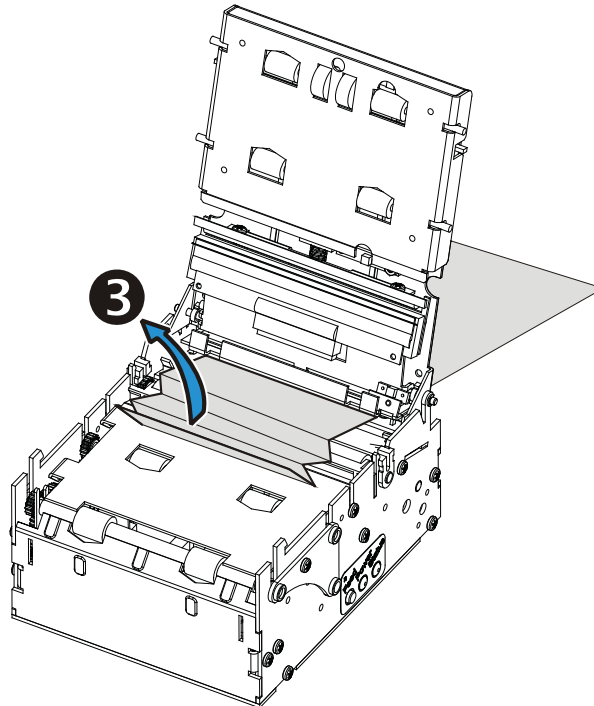



Zebra Technologies Corporation

Zebra Technologies Corporation
475 Half Day Road, Suite 500
Lincolnshire, IL 60069 USA
T: +1 847 634 6700
Toll-free +1 866 230 9494
F: +1 847 913 8766

Zebra Technologies Europe Limited

Dukes Meadow
Millboard Road
Bourne End
Buckinghamshire, SL8 5XF, UK
T: +44 (0)1628 556000
F: +44 (0)1628 556001

Zebra Technologies Asia Pacific, LLC

120 Robinson Road
#06-01 Parakou Building
Singapore 068913
T: +65 6858 0722
F: +65 6885 0838

<http://www.zebra.com>

© 2009 ZIH Corp.

P1021708-001

Free Manuals Download Website

<http://myh66.com>

<http://usermanuals.us>

<http://www.somanuals.com>

<http://www.4manuals.cc>

<http://www.manual-lib.com>

<http://www.404manual.com>

<http://www.luxmanual.com>

<http://aubethermostatmanual.com>

Golf course search by state

<http://golfingnear.com>

Email search by domain

<http://emailbydomain.com>

Auto manuals search

<http://auto.somanuals.com>

TV manuals search

<http://tv.somanuals.com>