

# S-Series User's Guide



**For the Zebra 105Se™  
and 160S™ Printers**



# **S-Series User's Guide**

---

**For the Zebra 105Se™  
and 160S™ Printers**

Customer Order # 31460L  
Manufacturer Part # 31460LB Rev. 2



## Proprietary Statement

This manual contains proprietary information of Zebra Technologies Corporation. It is intended solely for the information and use of parties operating and maintaining the equipment described herein. Such proprietary information may not be used, reproduced, or disclosed to any other parties for any other purpose without the expressed written permission of Zebra Technologies Corporation.

## Product Improvements

Continuous improvement of products is a policy of Zebra Technologies Corporation. All specifications and signs are subject to change without notice.

## FCC Compliance Statement

Note: This equipment has been tested and found to comply with the limits for a Class A digital Device, pursuant to Part 15 of the FCC Rules. These limits are designed to provide reasonable protection against harmful interference when the equipment is operated in a commercial environment. This equipment generates, uses and can radiate radio frequency energy and, if not installed and used in accordance with the instructions manual, may cause harmful interference to radio communications. Operation of this equipment in a residential area is likely to cause harmful interference in which case the user will be required to correct the interference at his own expense.

In order to insure compliance, this printer must be used with a Shielded Power Cord and Shielded Communication Cables.

“The user is cautioned that any changes or modifications not expressly approved by Zebra Technologies Corporation could void the user’s authority to operate the equipment.”

## Canadian DOC Compliance Statement

This digital apparatus does not exceed the Class A limits for radio noise emissions from digital apparatus as set out in the radio interference regulations of the Canadian Department of Communications.

## Liability Disclaimer

Zebra Technologies Corporation takes steps to assure that its published Engineering specifications and Manuals are correct; however, errors do occur. Zebra Technologies Corporation reserves the right to correct any such errors and disclaims liability resulting therefrom.

## No Liability for Consequential Damage

In no event shall Zebra Technologies Corporation or anyone else involved in the creation, production or delivery of the accompanying product (including hardware and software) be liable for any damages whatsoever (including, without limitation, damages for loss of business profits, business interruption, loss of business information, or other pecuniary loss) arising out of the use of or the results of use of or inability to use such product, even if Zebra Technologies Corporation has been advised of the possibility of such damages. Because some states do not allow the exclusion or limitation of liability for consequential or incidental damages, the above limitation may not apply to you.

## Copyrights

The copyrights in this manual and the label printer described therein are owned by Zebra Technologies Corporation. All rights are reserved. Unauthorized reproduction of this manual or the software in the label printer may result in imprisonment of up to one year and fines of up to \$10,000 (17 U.S.C.506). Copyright violators may be subject to civil liability.

© Zebra Technologies Corporation. All rights reserved.

All product and brand names are trademarks of their respective companies. All rights reserved.

# Table of Contents

---

## Introduction

Scope . . . . .	1-1
Model Designation . . . . .	1-1
System Overview . . . . .	1-1
Communication Capabilities . . . . .	1-2
Thermal Transfer Printer Internal Functions . . . . .	1-2
Print Mechanism Capabilities . . . . .	1-2
Media Transport Mechanism Capabilities . . . . .	1-2
Additional System Requirements . . . . .	1-3
Media and Ribbon Requirements . . . . .	1-3
Warnings and Precautions . . . . .	1-4
Installation . . . . .	1-4
230 VAC Operation . . . . .	1-4
Use of Shielded Cable . . . . .	1-4
Ribbons and Printhead Wear . . . . .	1-5
Repacking . . . . .	1-5
Printer Specifications . . . . .	1-6
Printing Considerations . . . . .	1-6
Print Speeds . . . . .	1-6
Media Handling . . . . .	1-6
Media . . . . .	1-7
Ribbon . . . . .	1-8
Zebra Programming Language II (ZPL II <sup>®</sup> ) . . . . .	1-8
Bar Codes . . . . .	1-8
Standard Fonts . . . . .	1-9
Standard Printer Font Example . . . . .	1-12
Physical . . . . .	1-12

Electrical . . . . .	1-12
Communications Interface . . . . .	1-13
Environmental Ranges . . . . .	1-13
Options and Accessories . . . . .	1-13

## Installation

Unpacking . . . . .	2-1
Inspection . . . . .	2-1
Reporting Damage . . . . .	2-1
Storage and Reshipping . . . . .	2-1
Power Connection . . . . .	2-2
AC Voltage Selection Procedure . . . . .	2-2
AC Power Fuse Replacement . . . . .	2-3
115 VAC Operation . . . . .	2-3
230 VAC Operation . . . . .	2-3
Site Requirements . . . . .	2-4
Ribbon Loading (105Se) . . . . .	2-4
Ribbon Loading (160S) . . . . .	2-7
Media Loading . . . . .	2-8
Roll Media . . . . .	2-8
Tear-Off Mode . . . . .	2-10
Rewind Mode . . . . .	2-10
Peel-Off Mode . . . . .	2-10
Cutter Mode . . . . .	2-11
Fanfold Media . . . . .	2-11
Removing Used Ribbon (105Se) . . . . .	2-12
Removing Used Ribbon (160S) . . . . .	2-13
Initial Printer Power Up . . . . .	2-14

# Operation

Operating Your Zebra S-Series Printer	3-1
Printer Operating Modes	3-1
Media Sensing Modes	3-1
Transmissive Sensing Mode	3-2
Black-Mark Sensing Mode	3-2
Media Transport Modes	3-2
Tear-Off Mode	3-2
Peel-Off Mode	3-3
Rewind Mode	3-3
Cutter Mode	3-3
Front Panel Keys	3-4
PAUSE Key	3-4
FEED Key	3-4
CANCEL Key	3-4
MODE Key	3-5
Front Panel Lights	3-5
Power On Self Test	3-7
Printer Self Tests	3-7
Introduction	3-7
CANCEL Key Self Test	3-9
PAUSE Key Self Test	3-10
FEED Key Test	3-11
FEED Key and PAUSE Key Test	3-12
MODE Key Test	3-12
PAUSE Key and CANCEL Key Test	3-12
FEED Key and CANCEL Key Test	3-13
Extended Printer Diagnostics	3-13

Sample ZPL II Label Formats . . . . .	3-14
Format 1: Simple Text and a Barcode . . . . .	3-15
Format 2: Saving a Label Format As a Graphic Image . . . . .	3-15
Format 3: Using a Serialized Data Field. . . . .	3-16

## Configuration and Calibration

Option Switches . . . . .	4-1
Bank 1 ( <i>For Serial-Interface Printers Only</i> ) . . . . .	4-2
Bank 2 . . . . .	4-3
Configuration Mode . . . . .	4-4
Calibration. . . . .	4-4
Adjusting the Print Darkness . . . . .	4-6
Adjusting the Media Rest Position . . . . .	4-6
Adjusting the Position of the Top of the Label . . . . .	4-6

## Interconnections

System Components . . . . .	5-1
System Considerations . . . . .	5-1
Communications Code . . . . .	5-1
Interfaces . . . . .	5-1
Data Specifications . . . . .	5-2
RS-232 Serial Data Port . . . . .	5-2
Hardware Control Signal Descriptions . . . . .	5-3
RS-232 Cabling Requirements . . . . .	5-3
Interconnect to DTE Devices . . . . .	5-4
Interconnect to DCE Devices . . . . .	5-4
Parallel Cabling Requirements . . . . .	5-5
Parallel Interface . . . . .	5-5
Signal Descriptions . . . . .	5-6

## Preventive Maintenance

Overview . . . . .	6-1
Cleaning . . . . .	6-1
Exterior Surfaces . . . . .	6-1
Interior. . . . .	6-1
Printhead and Platen Roller . . . . .	6-2
Media, Ribbon, and Label Available Sensors. . . . .	6-3
Cutter Module. . . . .	6-3
Lubrication . . . . .	6-4

## Adjustments

Toggle Positioning . . . . .	7-1
Printhead Pressure Adjustment . . . . .	7-1
Black-Mark Media Sensor Position Adjustment . . . . .	7-2
Transmissive Media Sensor Position Adjustment. . . . .	7-2
Upper Media Sensor . . . . .	7-3
Lower Media Sensor . . . . .	7-4
Media and Ribbon Sensor Sensitivity Adjustment . . . . .	7-5

## Troubleshooting

Troubleshooting . . . . .	8-1
---------------------------	-----

## Options

Peel-Off . . . . .	9-1
Cutter Module . . . . .	9-1
Media Rewind . . . . .	9-1
Fanfold Supply Bin . . . . .	9-2
ZebraNet (Ethernet) Interface . . . . .	9-2



Black-Mark (Reflective) Sensor (105Se Only) . . . . .	9-2
Optional Printer Fonts . . . . .	9-3
230 VAC Factory Setup . . . . .	9-3
Memory Option . . . . .	9-4
12-Dot/mm and 6-Dot/mm Printheads (105Se Only) . . . . .	9-4

## **Appendix A**

230 VAC Power Cord. . . . .	A-1
-----------------------------	-----

## **Appendix B**

ASCII Code Chart. . . . .	B-1
---------------------------	-----

## **Appendix C**

Adjusting Bar Code Darkness. . . . .	C-1
--------------------------------------	-----

## **Appendix D**

Optional Printer Fonts . . . . .	D-1
----------------------------------	-----

## **Glossary**

## **Index**

## Scope

This user's guide contains descriptive information and operational instructions for the Zebra 105Se and 160S thermal transfer demand printers. It contains information on how to set up and operate the printer as well as adjustment and maintenance procedures that can be performed by the operator. Information covering the use and operation of Zebra S-Series Printer options is also included.

Additional documentation for the Zebra S-Series Printer is available:

- The *ZPL II<sup>®</sup> Programming Guide* (part # 46469L).
- The two-volume Maintenance Manual: *Volume 1: General Maintenance* (part # 38452L) contains the information you will need to maintain your printer. *Volume 2: Circuit Descriptions and Electrical Schematics* (part # 38453L) contains the information you will need to repair the circuit boards at the component level. You may order both volumes as a set by ordering part # 31452L.

## Model Designation

Labels located inside the media compartment above the frame support at the rear of the S-Series Printer include both the serial number and model designation. If you need to contact our technical support staff for assistance, please have both the model designation and serial number available so that we may help you more efficiently.

## System Overview

The S-Series Printer, when connected to an appropriate ASCII data source, functions as a complete label, ticket, and tag printing system. Customer-supplied asynchronous modems may be used to connect remote hosts to the S-Series Printer.

Connection of the S-Series Printer to data sources using data codes other than ASCII requires the use of an appropriate protocol converter. Connection to data sources using interfaces other than the type installed in the printer requires the use of an appropriate interface converter.

## *Communication Capabilities*

The S-Series Printer comes with either an Electronics Industries Association (EIA) RS-232 serial data interface or a factory-installed parallel interface. In both cases, the required interface cable is not supplied with the printer.

## *Thermal Transfer Printer Internal Functions*

Command/control data signals are received via the RS-232 port, parallel port, or DIP switches and are sent to the main logic board. The microprocessor continuously monitors these signals along with the inputs received from the control panel and various sensors. The microprocessor interprets this information and controls the S-Series Printer mechanics, printhead, communications, command interpretation, label formatting, media control, and mechanical drive.

## *Print Mechanism Capabilities*

The print mechanism has been designed to print random information labels, tickets, and tags. It uses a thermal printhead that heats a ribbon as it passes beneath the print elements, melting its ink onto the media (direct thermal uses heat-sensitive media instead of an inked ribbon). Constant print speeds may be selected via software control.

The standard printhead for the S-Series Printer has a print resolution of 8 dots/mm (203.2 dots/inch). Optional printheads are available for the 105Se for either 6 dots/mm (152 dots/inch) or 12 dots/mm (300 dots/inch) resolution.

## *Media Transport Mechanism Capabilities*

The media transport mechanism of the S-Series Printer has been designed to accommodate various types of media, including die-cut labels, ticket and tag stock, continuous roll, and fanfold media.

Media may be rewound internally onto standard three-inch cores if the Rewind Spindle option is installed. With the Peel-off option, backing material may be rewound internally.

Ribbons for the S-Series Printer are supplied on one-inch cores in standard widths and lengths.

## Additional System Requirements

In addition to the Zebra S-Series Printer, you will need the following items to form a complete label preparation system:

- Label, ticket, or tag stock
- An intelligent device, such as a computer, for data entry or entry of ZPL II formats
- A data communication cable to connect the controlling device to the printer (remote installations may require additional cables and communication devices, such as modems and/or protocol converters)
- Thermal transfer ribbon (if using thermal transfer mode)

## Media and Ribbon Requirements

Print quality not only depends on the Zebra S-Series Printer, but also on the print media. Factors such as reflectivity and contrast are important for bar code scanning applications. Factors such as paper abrasion and temperature requirements are important in maintaining the life of the printhead.

We **STRONGLY RECOMMEND** the use of Zebra-brand media for continuous high quality printing. A wide range of paper, polypropylene, polyester, and vinyl stock has been specifically engineered to enhance the printing capabilities of the printer and to ensure against premature printhead wear.

Continuous roll form paper, fanfold media, or cardstock with optional perforations and registration holes may be used. The standard 160S Printer and 105Se Printer with an optional reflective sensor can use “black-mark media” (media having a black mark printed on the liner side for use in positioning the labels).

Since print quality is affected by media and ribbon, printing speeds, and printer operating modes, it is very important to **run tests for your applications**. This is especially true if you’re operating in Peel-Off mode, where these variables combine with label size, backing content, diecut depth, and even humidity to affect printer operation.

## Warnings and Precautions

### *Installation*

**CAUTION:** To ensure that the Zebra S-Series Printer has proper cooling, do not place any padding or cushioning material on the back of, or underneath, the unit.

### *230 VAC Operation*

**CAUTION:** Refer to “[Installation](#)” for instructions on configuring your printer for 230 VAC operation before connecting to a 230 VAC power source.

### *Use of Shielded Cable*

**CAUTION:** Refer to the “[Interconnections](#)” Section.

Zebra printers comply with FCC “Rules and Regulations”, Part 15, Subpart J, for Class A Equipment, using fully shielded data cables. Use of unshielded cables may increase radiated emissions above the Class A limits and is not recommended.

Zebra printers comply with international regulations governing radiated emissions when using fully shielded data cables. Use of unshielded cables may increase radiated emissions above the regulated limits.

## *Ribbons and Printhead Wear*

**CAUTION:** Ribbons used in the Zebra Technologies Corporation Printer MUST be as wide as or wider than the media. Zebra-brand ribbons provide an extremely smooth backing surface that protects the printhead from abrasion by the media. If the ribbon is narrower than the media, areas of the printhead will be unprotected and subject to premature wear.

## *Repacking*

**CAUTION:** If shipment of your printer is necessary, carefully pack the printer in a suitable container to avoid damage during transit. Whenever possible, use the original container from the factory. If the original container is not available, an optional packing kit can be purchased from Zebra. When using a different container, a procedure similar to the original factory packaging should be followed.

Refer to [“Installation”](#) for further repacking instructions.

# Printer Specifications

## Printing Considerations

Specification		105Se			160S
Resolution (thermal transfer or direct thermal)		203 dots per inch (8 dots per mm)	Optional 152 dots per inch (6 dots per mm)	Optional 300 dots per inch (12 dots per mm)	203 dots per inch (8 dots per mm)
Dot size		0.00492" (0.125 mm)	0.00656" (0.167 mm)	0.0033" x 0.0039" (0.084 x 0.100 mm)	0.00492" (0.125 mm)
Maximum print width		4.09" (104 mm)	4.09" (104 mm)	4.09" (104 mm)	6.30" (160 mm)
Maximum print length	Standard memory	15" (381 mm)	26" (660 mm)	18" (457 mm)	9.5" (241 mm)
	With 512 KB add'l memory	39" (991 mm)	39" (991 mm)	N/A	25" (635 mm)
Bar code modulus ("X") dimension		5 mil to 50 mil	6.6 mil to 66 mil	3.33 mil to 33.3 mil	5 mil to 50 mil
Thin film printhead with Energy Control					

## Print Speeds

Programmable constant printing speeds of 2" (51 mm), 3" (76 mm), 4" (102 mm), 5" (127 mm), and 6" (152 mm) per second.

The 105Se with optional 300 dots/inch resolution supports programmable constant printing speeds of 2.4" (61 mm), 3" (76 mm), and 4" (102 mm) per second.

## Media Handling

- Tear-off mode: Produced in strips.
- Peel-off mode: Requires Peel-Off option or Media Rewind option. Labels are dispensed and peeled from the liner, and the liner is rewind internally.
- Rewind mode: Requires Media Rewind option. A full roll of printed labels is rewind internally.
- Cutter mode: Requires Cutter Module option. Media cut after printing; under software control.

## Media

Media Specifications		105Se		160S		
Total media width	Maximum	4.5"	114.3 mm	7.2"	182.9 mm	
	Minimum	0.75"	19.05 mm	2.0"	50.8 mm	
Label length	Maximum	Refer to <a href="#">"Printing Considerations"</a> on page 1-6.				
	Minimum	Tear-Off	0.63"	16.00 mm	0.63"	16.00 mm
		Peel-Off	0.50"	12.8 mm	0.50"	12.8 mm
		Rewind	0.50"	12.8 mm	0.50"	12.8 mm
	Cutter	1.25"	31.75 mm	N/A	N/A	
Total thickness (includes liner)	Maximum (Printhead position may need to be adjusted above 0.01")	0.015"	0.381 mm	0.015"	0.381 mm	
	Minimum	0.0023"	0.0584 mm	0.0023"	0.0584 mm	
Core size		3.0"	76.2 mm	3.0"	76.2 mm	
Maximum roll diameter		8.0"	203.2 mm	8.0"	203.2 mm	
Interlabel gap (0.115"/3 mm preferred)		0.079" - 0.157"	2 mm - 4 mm	0.079" - 0.157"	2 mm - 4 mm	
Maximum internal fanfold media pack size (L x W x H)		8.0" x 7.2" x 6.2"	203.2 mm x 182.8 mm x 157.4 mm	8.0" x 7.2" x 6.2"	203.2 mm x 182.8 mm x 157.4 mm	
<b>Additional Specifications for Black-Mark Media (optional on 105Se)</b>						
Mark thickness (measuring parallel to label/tag edge)	Minimum	0.12"	3 mm	0.12"	3 mm	
	Maximum	0.43"	11 mm	0.43"	11 mm	
Mark width (measuring perpendicular to label/tag edge)	Minimum	0.43"	11 mm	0.43"	11 mm	
	Maximum	Full media width.		Full media width.		
Mark-to-mark registration tolerance		+/- 0.016"	+/- 0.4 mm	+/- 0.016"	+/- 0.4 mm	
Mark location		Mark <i>must</i> be located on the inside of the media (closest to the printer's mainframe when loaded in the printer).				
Mark density		> 1.0 ODU (Optical Density Unit)				
Density of the back of the media on which the black mark is printed		0.5 ODU maximum				



## Ribbon

Ribbon Width		105Se		160S		
<i>Zebra recommends using ribbon at least as wide as the media you are using to protect the printhead from wear.</i>		Maximum	4.33"	110 mm	6.89"	175 mm
		Minimum	0.94"	24 mm	2.0"	51 mm
Standard Lengths	2:1 media to ribbon roll ratio		984 ft	300 m	984 ft	300 m
	3:1 media to ribbon roll ratio		1476 ft	450 m	1476 ft	450 m
Roll size	Inner diameter of core		1.0"	25.4 mm	1.0"	25.4 mm
	Outside diameter of full roll of ribbon		3.2"	81 mm	3.2"	81 mm

## Zebra Programming Language II (ZPL II®)

- Downloadable graphics with data compression
- Bit image data transfer and printing, including mixing of text and graphics
- Format inversion
- Mirror image printing
- Four-position field rotation (0°, 90°, 180°, 270°)
- Bitmap and scalable fonts
- Programmable quantity with print pause
- Communicates in printable ASCII characters
- Controlled by a mainframe, minicomputer, PC, or other data entry device
- Serialized fields
- In-Spec OCR-A and OCR-B
- UPC/EAN [nominal 100% magnification (6 dots/mm and 12 dots/mm only)]

## Bar Codes

- Code 11, Code 49, Code 93
- Code 39 (Supports ratios of 2:1, 3:1, 5:2, 7:3)
- Code 128 (Supports serialization in subsets B and C and UCC Case C Codes)
- CODABAR (Supports ratios of 2:1, 3:1, and 5:2)
- Industrial 2 of 5, Standard 2 of 5
- Plessey
- MAXICODE
- UPC-A
- PDF 417
- POSTNET
- MSI
- E/EAN-8, E/EAN-13, EAN EXTENSIONS
- Interleaved 2 of 5
- 3 of 9
- Data Matrix

## Standard Fonts

The scalable smooth font (CG Triumvirate™ Bold Condensed) is expandable on a dot-by-dot basis, height- and width-independent, while maintaining smooth edges. Maximum size depends on available memory.

Fonts A, B, C, D, E, F, G, and H are expandable up to 10 times, height- and width-independent; however, fonts E and H (OCR-A and OCR-B) are not considered in-spec when expanded.

IBM Code Page 850 international character sets are standard in fonts A, B, C, D, E, F, G, and through software control.

Note: See *“Options”* for the availability of additional fonts.

Font Matrices for 8 dots/mm Printhead (105Se and 160S)										
Font	Matrix (in dots)			Type*	Character Size					
	Height	Width	Inter-character gap		Inches			Millimeters		
					Height	Width	Char./inch	Height	Width	Char./mm
A	9	5	1	U-L-D	0.044	0.029	33.90	1.13	0.75	1.33
B	11	7	2	U	0.054	0.044	22.60	1.38	1.13	0.89
C, D	18	10	2	U-L-D	0.088	0.059	16.95	2.25	1.50	0.67
E	28	15	5	OCR-B	0.138	0.098	10.17	3.50	2.50	0.40
F	26	13	3	U-L-D	0.128	0.079	12.71	3.25	2.00	0.50
G	60	40	8	U-L-D	0.295	0.236	4.24	7.50	6.00	0.17
H	21	13	6	OCR-A	0.103	0.093	10.71	2.63	2.38	0.42
GS	24	24	0	SYMBOL	0.118	0.118	8.48	3.00	3.00	0.33
0	Default: 15 x 12			U-L-D	Scalable					
* U = Uppercase, L = Lowercase, D = Descenders										

### Font Matrices for 6 dots/mm Printhead

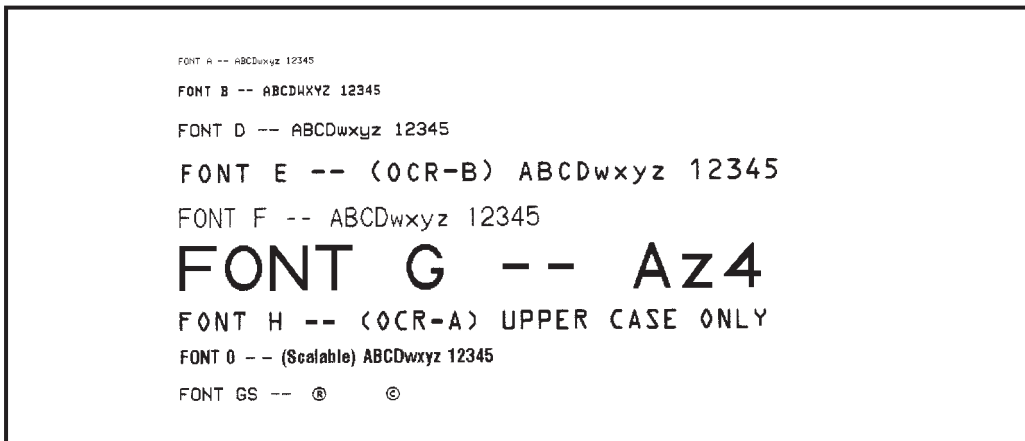
Font	Matrix (indots)			Type*	Character Size					
					Inches			Millimeters		
	Height	Width	Inter-character gap		Height	Width	Char./inch	Height	Width	Char./mm
A	9	5	1	U-L-D	0.059	0.039	25.40	1.50	1.00	1.00
B	11	7	2	U	0.072	0.059	16.93	1.83	1.50	0.67
C, D	18	10	2	U-L-D	0.118	0.079	12.70	3.00	2.00	0.50
E	21	10	3	OCR-B	0.138	0.085	11.72	3.50	2.17	0.46
F	26	13	3	U-L-D	0.171	0.105	9.53	4.33	2.67	0.38
G	60	40	8	U-L-D	0.394	0.315	3.18	10.00	8.00	0.13
H	17	11	4	OCR-A	0.112	0.098	10.16	2.83	2.50	0.40
GS	24	24	0	SYMBOL	0.157	0.157	6.35	4.00	4.00	0.25
0	Default: 15 x 12			U-L-D	Scalable					

\* U = Uppercase, L = Lowercase, D = Descenders

### Font Matrices for 12 dots/mm Printhead

Font	Matrix (indots)			Type*	Character Size					
	Height	Width	Inter-character gap		Inches			Millimeters		
					Height	Width	Char./inch	Height	Width	Char./mm
A	9	5	1	U-L-D	0.029	0.016	50.80	0.73	0.40	2.00
B	11	7	2	U	0.036	0.023	33.86	0.91	0.58	1.34
C, D	18	10	2	U-L-D	0.059	0.033	25.40	1.49	0.83	1.00
E	42	20	6	OCR-B	0.138	0.066	23.44	3.50	1.67	0.92
F	26	13	3	U-L-D	0.185	0.042	19.06	2.15	1.06	0.76
G	60	40	8	U-L-D	0.198	0.132	6.36	5.02	3.35	0.26
H	34	22	8	OCR-A	0.112	0.072	20.32	2.84	1.82	0.80
GS	24	24	0	SYMBOL	0.079	0.079	12.70	2.00	2.00	0.50
0	Default: 15 x 10			U-L-D	Scalable					
* U = Uppercase, L = Lowercase, D = Descenders										

## Standard Printer Font Example



### Physical

Physical Characteristics	105Se		160S	
Height	15.4"	391 mm	15.4"	391 mm
Width	10.5"	267 mm	13.1"	333 mm
Length	18.9"	480 mm	18.9"	480 mm
Weight (without options)	43 lbs.	19.5 kg	55 lbs.	24.9 kg

### Electrical

- 115 VAC +15%/-20% or 230 VAC +15%/-15%; 48-62 Hz
- 5 Amps @ 115V, 3 Amps @ 230V
- UL 1950 Listed-Certified to CAN/CSA-C22.2 No. 950- M89; classified to IEC 950; complies with FCC and Canadian DOC class “A” rules
- Carries the CE mark of compliance.

## Communications Interface

- RS-232 at 110 to 19,200 baud (select from standard rates). Baud rate, data bits, parity, error detection protocol, and XON-XOFF or DTR/DSR handshaking are all switch-selectable. Stop bits are fixed at 1
- Compatibility Mode Parallel Interface. Maximum cable length: 10 ft. (304.8 cm)

## Environmental Ranges

Operating temperature		+41°F to +104°F	+5°C to +40°C
Storage temperature		-40°F to +158°F	-40°C to +70°C
Non-condensing relative humidity	Operating	20% to 85%	
	Storage	20% to 85%	

## Options and Accessories

- Peel-Off capability only\*
- Cutter Module
- Cutter Catch Tray
- Media Rewind with rewind and peel-off capabilities\*
- Fanfold Supply Bin
- ZebraNet™
- Black-Mark (Reflective) Sensor (105Se only)
- Scalable and bit-mapped smooth fonts
- Additional 512 KB memory (not available for 105Se [300 dots/inch])

\* Peel Off and Media Rewind options are mutually exclusive of the Cutter option.



## Unpacking

When unpacking the Zebra S-Series Printer, make sure you save all packing materials. Once the printer is out of the box, raise the printer's Media Access Door and remove the power cord.

## Inspection

Inspect the printer for possible damage incurred during shipment.

- Check all exterior surfaces for damage.
- Raise the Media Access Door and inspect compartment for damage to components.

## Reporting Damage

If you discover shipping damage upon inspection:

- Immediately notify the shipping company of the damage.
- Retain all packaging material for shipping company inspection.
- File a damage report with the shipping company and notify your local distributor and Zebra Technologies Corporation of the damage. *Zebra Technologies Corporation is not responsible for any damage incurred during shipment of the equipment and will not repair this damage under warranty.* Immediate notification of damage to the shipping company or its insuring agency will generally result in ensuring any damage claim validity and ultimate monetary compensation.

## Storage and Reshipping

If you are not placing the printer into operation immediately, repackage it using the original packing materials. The S-Series Printer may be stored under the following conditions:



- Temperature: -40° to +158° F (-40° to +70° C)
- Relative humidity: 20% to 85% non-condensing

Should it become necessary to ship your printer, **remove any ribbon and paper roll** from the supply spools, otherwise damage to the printer could result. Carefully pack the printer in a suitable container to avoid damage during transit. Whenever possible, use the original container and packaging material from the factory. If you use a different container, a procedure similar to the original factory packaging should be followed.

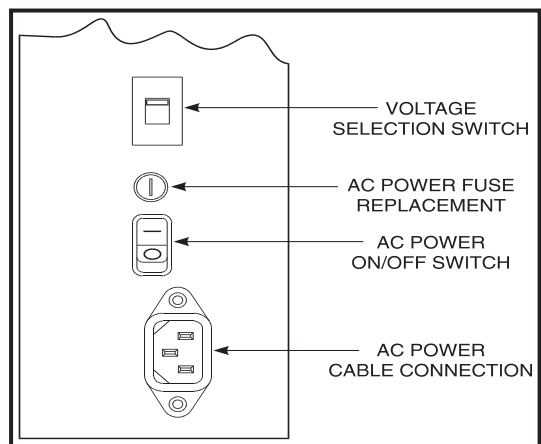
**CAUTION:** Do not package the printer in a rigid container without utilizing shock mounts or shock-absorbing packing material. A rigid container will allow shock on the outside to be transmitted undamped to the unit, which may cause damage.

## Power Connection

### *AC Voltage Selection Procedure*

The S-Series Printer's AC voltage may be set for either 115 VAC or 230 VAC operation. To match the printer's power entry selection to the available power source, refer to Figure 2.1 and follow the procedure outlined below:

1. Locate the AC power area at the rear of the printer.
2. Using a small flatblade screwdriver or similar tool, move the Voltage Selection switch to the 115 V or 230 V position as required. (The initial position of the switch depends on how the printer was ordered.) Make sure that the appropriate fuse is in place. See Figure 2.1.



**Figure 2.1 AC Power Area**

## AC Power Fuse Replacement

A user-replaceable AC Power Fuse is located just above the Power ON/OFF Switch (see [Figure 2.1](#)). For a 115 VAC installation, the replacement fuse is a 3AG Fast Blow style rated at 5 Amp/250VAC. For a 230 VAC installation, the fuse is the same style but rated at 3 Amp/250 VAC. ***Make sure the fuse you use is correct for the voltage source.***

Before replacing the fuse, turn the AC Power Switch OFF and unplug the AC Power Cable.

To replace the fuse, insert the tip of a flatblade screwdriver into the slot in the end of the Fuse Holder End Cap. Press in slightly on the End Cap and turn the screwdriver slightly counterclockwise. This will disengage the End Cap from the Fuse Holder and allow you to remove the fuse. To install a new fuse, reverse the procedure.

### 115 VAC Operation

1. Confirm that the voltage selector switch is set to 115 V.
2. Attach the supplied power cord to the AC power receptacle located on the rear of the printer.
3. Connect the opposite end of the power cord to a properly grounded source of 115 VAC (50 or 60 Hz) power rated for at least 5 Amps.

### 230 VAC Operation

1. Confirm that the voltage selector switch is set to 230 V.
2. Depending on how the printer was ordered, a power cord may or may not be provided for 230 VAC operation. If not provided, obtain a cord set with the proper AC Power plug. The cord may then be connected to the standard (international) IEC-type 3-prong AC connector provided on the S-Series Printer. Refer to [“Appendix A”](#) for more information.

## Site Requirements

**CAUTION:** To ensure that the S-Series Printer has proper ventilation and cooling, do not place any padding or cushioning material on the back of or underneath the unit because this will restrict the air flow.

The S-Series Printer may be installed on any solid, level surface of sufficient size and strength to accommodate the unit. The area in which the printer will operate must meet the environmental conditions specified.

Since the Zebra S-Series Printer was designed and is fabricated as an industrial-type unit, it will function satisfactorily in areas such as a warehouse or factory floor that conform to the specified environmental and electrical conditions.

## Ribbon Loading (105Se)

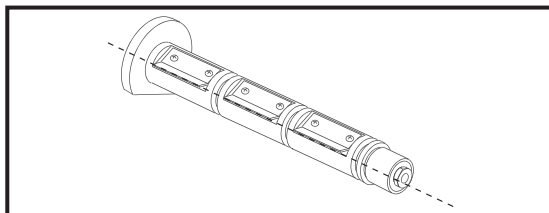
Refer to [Figure 2.4](#) throughout this procedure.

**Note:** When placing the ribbon roll on the Ribbon Supply Spindle, make sure that the core is pushed up against the stop on the ribbon supply spindle and that the ribbon is aligned squarely with its core. If this is not done, the ribbon may not cover the inside edge of the printhead, exposing print elements to potentially damaging contact with the media.

**Note:** Do not load ribbon if the printer is to be used in the Direct Thermal Mode.

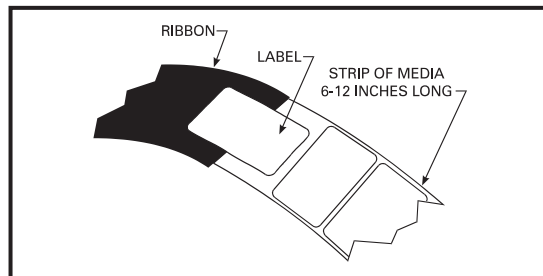
**CAUTION:** Do not use ribbon that is narrower than the media. If the printhead is not protected by the smooth backing of the ribbon, excessive abrasion may cause premature printhead failure.

1. Align the segments of the Ribbon Supply Spindle. See Figure 2.2.

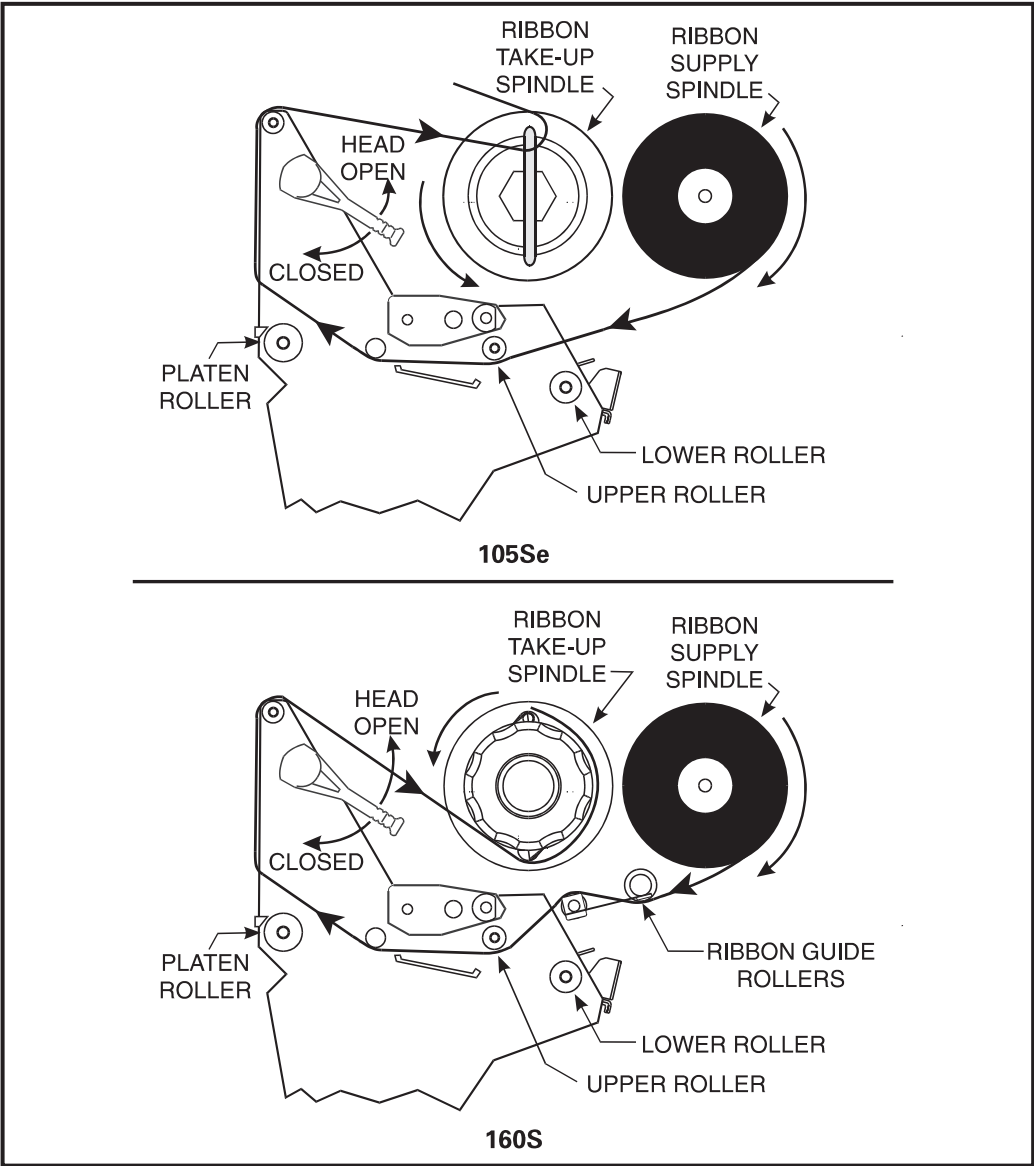


**Figure 2.2 Spindle Alignment**

2. Place the Ribbon Roll on the Ribbon Supply Spindle.
3. Open the printhead by moving the handle to the OPEN position.
4. **Important.....**To make ribbon loading and unloading easier, make a leader for your ribbon roll if it doesn't already have one (refer to Figure 2.3):  
Tear off a strip of media (labels and backing) about 6 to 12 inches long from the roll.  
Peel off a label from this strip. Remove the remaining labels. Apply half of this label to the end of the strip and the other half to the end of the ribbon. This acts as a ribbon leader.
5. Thread the leader and attached ribbon as shown in the illustration. Be careful not to crease or wrinkle the ribbon.
6. Remove the Hook from the Ribbon Take-Up Spindle.
7. Place the leader under the long leg of the Hook and wind for several turns.
8. Close the printhead by moving the lever to the CLOSED position.



**Figure 2.3 Making a Leader**



**Figure 2.4 Ribbon Loading Diagram**

## Ribbon Loading (160S)

Refer to [Figure 2.4](#) throughout this procedure.

**Note:** When placing the ribbon roll on the Ribbon Supply Spindle, make sure that the core is pushed up against the stop on the ribbon supply spindle and that the ribbon is aligned squarely with its core. If this is not done, the ribbon may not cover the inside edge of the printhead, exposing print elements to potentially damaging contact with the media.

**Note:** **Do not** load ribbon if the printer is to be used in the Direct Thermal Mode.

**CAUTION:** **Do not** use ribbon that is narrower than the media. If the printhead is not protected by the smooth backing of the ribbon, excessive abrasion may cause premature printhead failure.

1. Align the segments of the Ribbon Supply Spindle. See [Figure 2.2](#).
2. Place the Ribbon Roll on the Ribbon Supply Spindle.
3. Open the printhead by moving the handle to the OPEN position.
4. **Important.....**To make ribbon loading and unloading easier, make a leader for your ribbon roll if it doesn't already have one (refer to [Figure 2.3](#)):  
Tear off a strip of media (labels and backing) about 6 to 12 inches long from the roll. Peel off a label from this strip. Remove the remaining labels. Apply half of this label to the end of the strip and the other half to the end of the ribbon. This acts as a ribbon leader.
5. Thread the leader and attached ribbon as shown in the illustration. Be careful not to crease or wrinkle the ribbon.
6. Place the leader around the Ribbon Take-Up Spindle and wind counter-clockwise for several turns.
7. Close the printhead by moving the lever to the CLOSED position.

## Media Loading

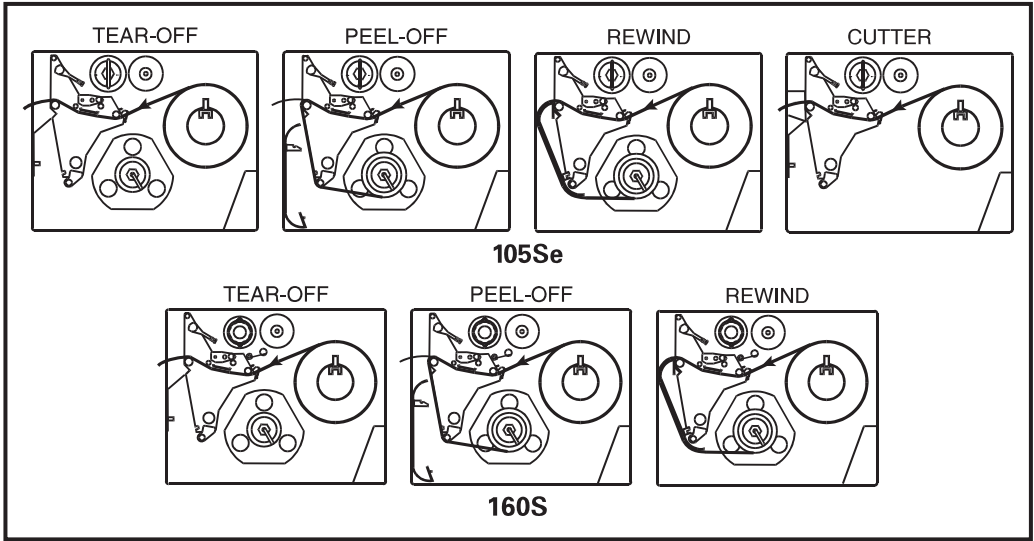
To load media, move the Printhead Locking Lever to the OPEN position. Refer to Figures 2.5, 2.6, 2.7, and 2.8. When the media is loaded, close the printhead by moving the lever on the upper printhead mechanism to the CLOSED position.

**Note:** The first time you load media and whenever you subsequently change the media type you must re-calibrate the printer. See the Configuration and Calibration Section.

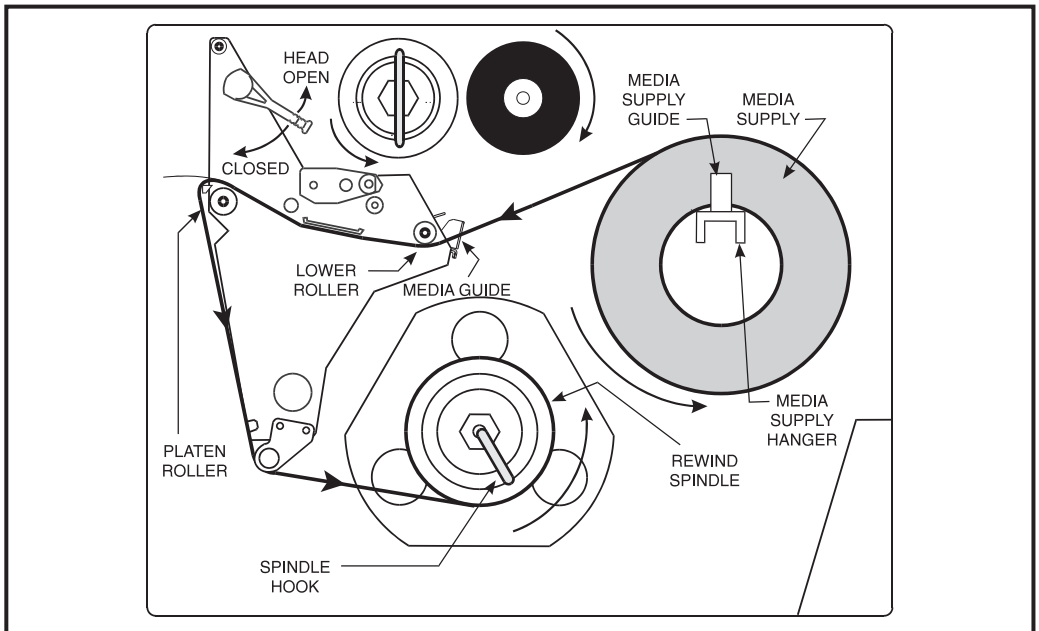
### *Roll Media*

Roll media may contain labels of a fixed length with gaps in between or it may be formed as one continuous length with no gaps (see *Continuous Media* in the Glossary). Both types of roll media mount inside the printer in the same manner. To load roll media, refer to Figure 2.5 and/or 2.6 and do the following:

1. Move the Media Guide and Media Supply Guide as far away from the printer frame as possible.
2. Place the media roll on the Media Supply Hanger.
3. Push the Media Supply Guide inward until it is just touching the outer side of the Media Supply Roll. (The Guide must not cause pressure or excessive drag on the Media Supply Roll.)
4. Thread the media through the printhead as shown in the illustrations.
5. Adjust the Media Guide until it just touches the outer edge of the media without causing it to buckle.
6. Close the printhead by moving the lever located on the upper printhead assembly to the CLOSED position.



**Figure 2.5 Roll Media Loading Diagrams**



**Figure 2.6 105Se Roll Media Loading (with Peel-Off)**



## *Tear-Off Mode*

Follow the instructions described in Roll Media.

## *Rewind Mode*

The Rewind Option must be installed in the printer. To initially configure the printer for this mode, follow these steps:

1. Remove the Media Rewind Plate from its storage location in front of the printhead inside the media compartment.
2. Invert the Rewind Plate so that the lip on the attached Hook Plate points down.
3. Insert the Hook Plate lip a short distance (1/2") into the lower opening in the Side Plate.
4. Align the upper end of the Rewind Plate with the corresponding opening in the Side Plate and slide the Rewind Plate in so that it stops against the Main Frame.
5. Remove the Hook from the Take-Up Spindle Shaft.
6. Route the media as shown in Figures 2.5 and 2.6, wind it 1-2 times around a 3" core.

## *Peel-Off Mode*

After loading the media, follow these steps:

1. Remove the Rewind Plate if one is present and store it on the two mounting screws on the inside of the front panel. Align the notch or web in the media so that the Take Label Sensor can sense a peeled label.
2. Load media as shown in Figures 2.5 and 2.6.
3. Remove the Hook from the Take-Up Spindle Shaft.
4. Remove several labels from the media backing and then wind the backing 1-2 times around the Media Take-Up Spindle and reinstall the Hook.

## Cutter Mode

Follow the instructions described in Roll Media with the exception of step 6: first route the media through the Cutter Module (see Figures 2.5 and 2.6) and then close the printhead assembly by moving the lever located on the upper printhead assembly to the CLOSED position.

## Fanfold Media

To load fanfold media, place the fanfold media in the bottom or to the rear of the media compartment or Fanfold Supply Bin (105Se only) and thread it through the printhead as shown in Figures 2.7 and 2.8. Adjust the media guide using the thumb screw to keep the media from drifting left or right.

Fanfold media from outside the printer feeds through one of the two access slots, one at the bottom of the printer and one at the rear.

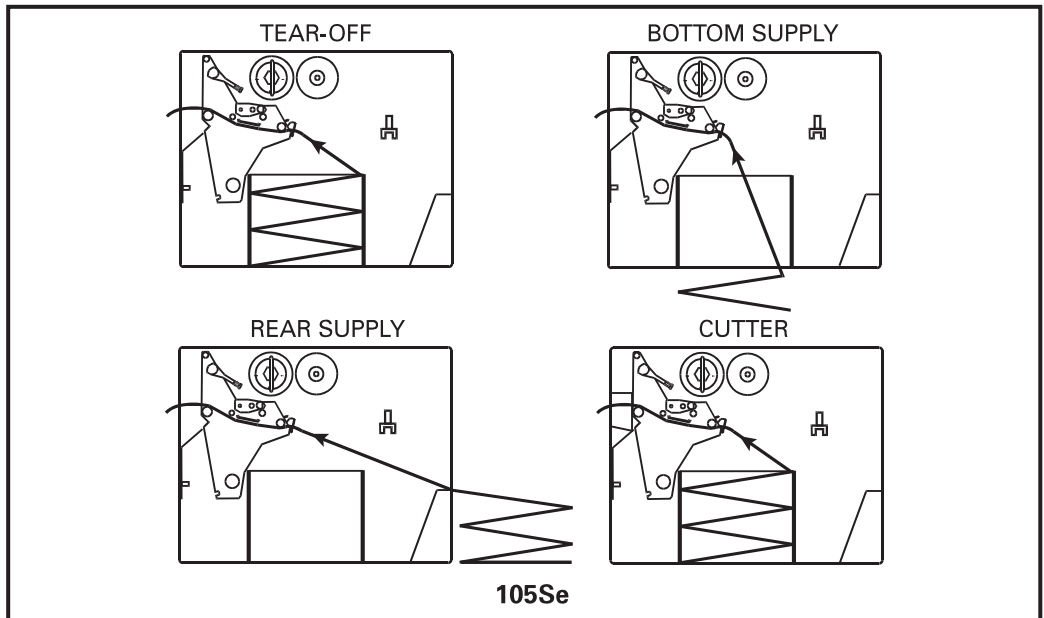
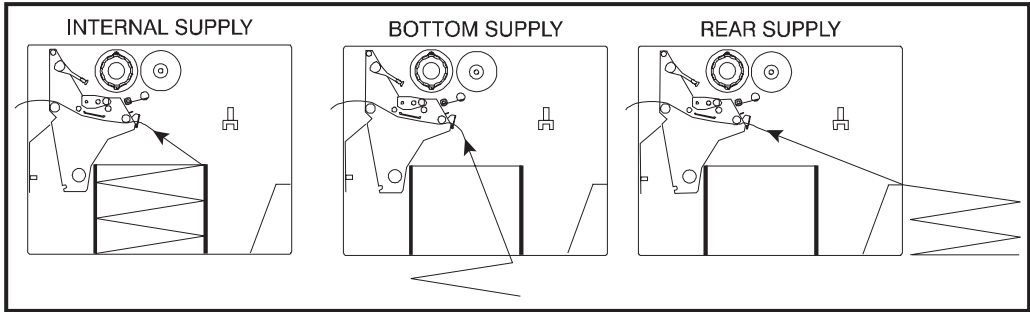


Figure 2.7 Fanfold Media Loading Diagrams (105Se)

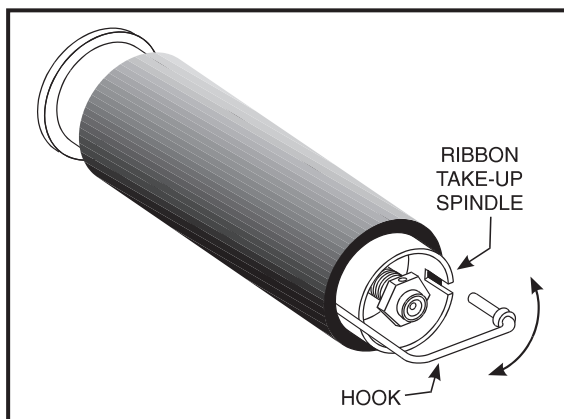


**Figure 2.8 Fanfold Media Loading Diagrams (160S)**

## Removing Used Ribbon (105Se)

To remove used ribbon, refer to Figure 2.9 and follow the steps below.

1. Pull the hook out slightly, then rotate the hook back-and-forth several times as shown and remove it from the spindle.
2. Grasp the used ribbon and remove it from the Ribbon Take-Up Spindle.
3. Remove the empty core from the Ribbon Supply Spindle.
4. Follow the [Ribbon Loading procedure on page 2-4](#) to load the new ribbon.



**Figure 2.9 Removing Used Ribbon (105Se)**

## Removing Used Ribbon (160S)

Refer to Figure 2.10.

1. Turn the knob at the end of the Ribbon Take-Up Spindle (1) clockwise until it stops. This will cause the Ribbon Release Bars to pivot down (2), easing the spindle's "grip" on the wound ribbon.
2. Slide the ribbon off of the Ribbon Take-Up Spindle. Once the used ribbon has been removed, ensure that the arrow on the knob aligns with the indented notch in the Ribbon Take-Up Spindle (see inset).
3. Remove the empty core from the Ribbon Supply Spindle.
4. Follow the [ribbon loading procedure on page 2-7](#) to load the new ribbon.

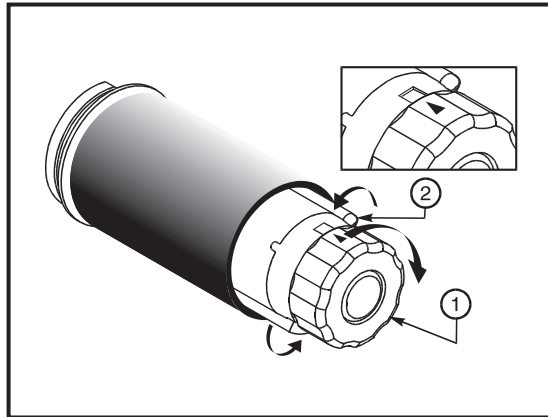


Figure 2.10 Removing Used Ribbon (160S)

## Initial Printer Power Up

After you finish loading the ribbon and media, continue reading through [“Operation”](#) and [“Configuration and Calibration.”](#) Perform the following initial printer power-up steps as you come to them:

1. Power On Self Test (POST)
2. Calibration

Subsequent power-ups will not necessarily require step 2 to be performed. See [“Operation”](#) and [“Configuration and Calibration”](#) for further information.

## Operating Your Zebra S-Series Printer

Now that your printer is ready for operation, how does it work? The Zebra S-Series Printer is designed to receive instructions from a host computer, such as an IBM-compatible PC. To create a label, you will either need to use label design software or write a format in ZPL II<sup>®</sup>, which is a programming language for creating label formats. If you are using label design software, refer to the instructions provided with your software package to determine how to proceed.

If you are using, or plan to use, ZPL II, make sure you have a copy of the *ZPL II Programming Guide*. This guide was available at the time you ordered your printer, but if you do not have a copy then submit the mail- or fax-in card in the front of this book to get a copy. For some sample ZPL II label formats, refer to the information at the end of this chapter. But first, we'll describe the different operating modes.

## Printer Operating Modes

The S-Series Printer can be configured for several different modes of operation by sending the proper commands from the host computer. Operating modes may also be configured via a bank of DIP switches at the rear of the printer. (See [“Configuration and Calibration”](#) for more information about DIP switches.)

### *Media Sensing Modes*

There are two basic modes by which the printer can sense the position of the media: Transmissive Sensing Mode and Black-Mark Sensing Mode. The 160S comes standard with both Transmissive Sensing Mode and Black-Mark Sensing Mode capabilities. The 105Se comes standard with Transmissive Sensing Mode capability, but may be factory ordered with an additional Black Mark Sensor.

## **Transmissive Sensing Mode**

In Transmissive Sensing Mode, a sensor detects a light shining through a web, notch, or hole in non-continuous media. In this way, the printer determines the position of the label/tag.

## **Black-Mark Sensing Mode**

In Black-Mark Sensing Mode, you use media having black marks printed on the back of the label liner for each label. To determine the label length and top of label, the printer's Black Mark Sensor detects the black mark similar to the way in which the Transmissive Sensor detects the notch or gap in the media.

## *Media Transport Modes*

### **Tear-Off Mode**

When the media is in the rest (idle) position, the webbing between labels is over the Tear-Off/Peel-Off Bar. To print a label, the printer first backfeeds the media until the start of the label is directly under the printhead and then prints the entire label.

After a label is printed, the media feeds forward until the end of the label is past the Tear-Off/Peel-Off Bar. This label position is determined by commands sent to the printer from the host computer or by front panel adjustments.

When a quantity of labels is required, a format for printing a batch of labels can be sent to the printer. Once a label is printed, the media will feed forward to the start of the next label and printing will continue. In this way, the printer will print the batch and stop when it reaches the quantity required.

When a quantity of individual labels is required, the format for printing a batch of labels can still be sent to the printer. The operator can use the PAUSE Key to cycle the printing one label at a time. The operator can then tear off each label before printing the next one.

## Peel-Off Mode

When the media is in the rest (idle) position, the start of the label to be printed is slightly in front of the printhead. To print a label, the printer first backfeeds the media until the start of the label is directly under the printhead and then prints the entire label.

In this mode, once the label is printed, the media passes over the Tear-Off/Peel-Off Bar at an extremely sharp angle. The backing material is peeled away from the label and winds around the Peel-Off Spindle or the Media Rewind Spindle. The media feeds forward until most of the label hangs loose from the backing. The label is held in this position by that portion of the backing that has not crossed the Tear-Off/Peel-Off Bar.

The Label Available Sensor is located on the printer in a position where it is activated by the label. When the operator removes the label, the printer backfeeds the media either to the rest (idle) position or to the printing position and prints the next label. When it is necessary to remove the media backing from the Take-Up Spindle, you do not need to turn the printer OFF.

## Rewind Mode

Some applications call for the media to be rewound onto a core as the labels are printed.

When the media is in the rest (idle) position, the start of the next label is directly under the printhead. After the label is printed, the media feeds forward until the start of the next label is under the printhead. The media never backfeeds in this mode.

When the printer completes a batch of labels, printing will stop.

## Cutter Mode

In this mode the cutter, under software control, automatically cuts individual labels (or at the end of batches of labels) after printing. The optional Cutter Catch Tray gathers the completed labels.



# Front Panel Keys

## PAUSE Key

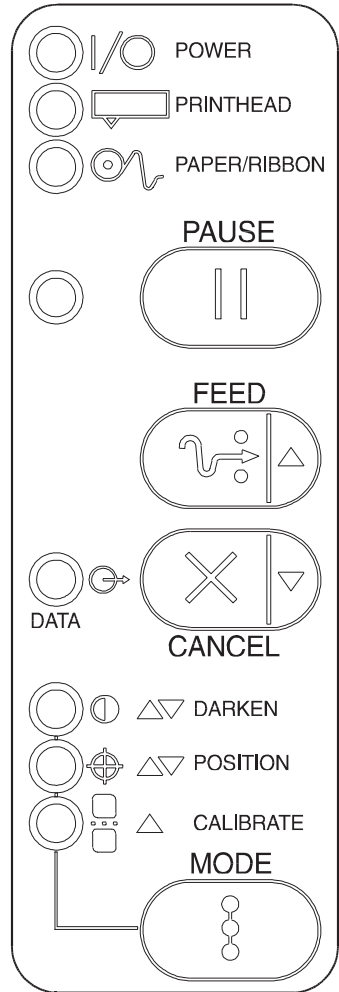
The PAUSE key stops and restarts the printing process. If the printer is idle (not printing) when the PAUSE key is pressed, no printing can occur. If the PAUSE key is pressed while printing is in progress, the printing stops once the current label is complete. Pressing the PAUSE key a second time resumes the printing process.

## FEED Key

The FEED key forces the printer to feed one blank label. If the printer is idle, or if the PAUSE function is active when the FEED key is pressed, one blank label feeds from the printer immediately. If the printer is printing, then one blank label feeds out after completion of the current batch of labels. After one blank label feeds out, pressing FEED again provides another blank label.

## CANCEL Key

The CANCEL key is only recognized in PAUSE mode. Press CANCEL to cancel the current label format. If no format is printing, then the next one to be printed will be canceled. If no formats are in memory, the CANCEL key is ignored. If the CANCEL key is pressed for an extended period of time (3 seconds), the printer cancels all formats in memory and the DATA light turns OFF.



**Figure 3.1**  
**Printer Front Panel**

## *MODE Key*

The MODE key puts the printer in Configuration Mode. In this mode, you can adjust the Print Darkness, Media Tear-Off Position, and Label Top Position, or perform a Calibration. See “[Configuration and Calibration.](#)”

## **Front Panel Lights**

Refer to [Figure 3.1](#) for the location of the lights.

**Note:** If an operating condition which causes a light to be ON constantly and one which causes the same light to flash occur simultaneously, the light flashes.

Indicator Light Name	Status	Indication
POWER	ON	Printer is ON.
PRINTHEAD	OFF	Normal operation.
	ON	Head Over Temperature condition. Printing stops until the printhead cools down. Printing resumes automatically.
		Printhead Under Temperature condition. Printing continues.
		Power Supply Over Temperature condition. Printing stops until the power supply cools down. Printing resumes automatically.
	Flashing	Printhead Open.
PAPER/ RIBBON	OFF	Media and ribbon (if used) are properly loaded.
	ON	Paper out.
	Flashing	1. In Thermal Transfer Mode: Ribbon is out.
		2. In Direct Thermal Mode: Ribbon is in the printer.
PAUSE	OFF	Normal operation.
	ON	Printer has stopped all printing operations.
DATA	OFF	Normal operation, no data being received.
	ON	Labels are printing.
	Single flash	The <b>CANCEL</b> key was pressed and a format was successfully deleted from the print queue.
	Flashing	Receiving data from host computer.
	Slow flashing	Printer sent a “stop transmitting” command to the host computer.
DARKEN	ON	Printer is in the Configuration Mode. See <a href="#">“Configuration and Calibration”</a> for more information.
POSITION	ON	
CALIBRATE	ON	

## Power On Self Test

A Power On Self Test (POST) is performed each time the printer is turned ON. This test checks for proper initialization of various electronic circuits and establishes starting parameters as those stored in the printer's memory. During this test sequence, the front panel lights will turn ON and OFF to ensure proper operation. At the end of this self test, only the POWER light will remain lit. If other lights are also lit, refer to the [Troubleshooting Section](#).

## Printer Self Tests

### *Introduction*

These self tests produce sample labels and provide specific information that helps determine the operating conditions for the printer.

Each self test is enabled by holding in a specific Front Panel key or combination of keys while turning the Power Switch ON. Keep the key depressed until the Front Panel Lights turn ON.

When the Power On Self Test is completed, the selected self test automatically starts.

**Notes:** When performing self tests, all data interface cables connected to the rear of the printer must be removed.

When canceling a self test before its actual completion, always turn the printer Power OFF and then back ON to reset the printer.

When performing these self tests in the Peel-Off Mode, the operator must remove the labels as they become available.

Unless specifically stated, all tests print in Tear-Off mode in Tear-Off printers and in Peel-Off Mode for Peel and Rewind printers.

If your media is not wide enough, the test labels will only print out to the edge of the label. If your media is too short, the test label will continue printing on the next label.

Some of the printer self tests produce labels at varying print speeds. These speeds may be referred to as “inches per second,” “millimeters per second,” or by alphabetic letter designation (i.e., “A,” “B,” “C,” etc.). The following chart shows the relationships between the different speeds.

<b>Letter Designation</b>	<b>English</b>	<b>Metric</b>
A*	2"/sec.	51 mm/sec.
B	3"/sec.	76 mm/sec.
C	4"/sec.	102 mm/sec.
	5"/sec.	127 mm/sec.
D	6"/sec.	152 mm/sec.

\* Speed “A” for the 105Se with the optional 300 dots-per-inch print-head is 2.4" (61 mm).

## CANCEL Key Self Test

This self test prints a single label which contains a listing of the printer's current configuration parameters stored in Configuration (EEPROM) Memory. Press the CANCEL key while turning the AC Power Switch ON. See Figure 3.2.

PRINTER CONFIGURATION	
+30.....	DARKNESS
+0.....	TEAR OFF
CUTTER.....	PRINT MODE
NON-CONTINUOUS.....	MEDIA TYPE
MARK.....	SENSOR TYPE
THERMAL-TRANS.....	PRINT METHOD
104 0/8 MM.....	PRINT WIDTH
1230.....	LABEL LENGTH
39.0IN 988MM.....	MAXIMUM LENGTH
MAIN RS232.....	HOST PORT
NONE.....	Z-NET PORT
19200.....	BAUD
8 BITS.....	DATA BITS
NONE.....	PARITY
1 STOP BIT.....	STOP BITS
XON/XOFF.....	HOST HANDSHAKE
NONE.....	PROTOCOL
000.....	NETWORK ID
NORMAL MODE.....	COMMUNICATIONS
< > 7EH.....	CONTROL PREFIX
<^> 5EH.....	FORMAT PREFIX
<, > 2CH.....	DELIMITER CHAR
FEED.....	MEDIA POWER UP
FEED.....	HEAD CLOSE
DEFAULT.....	BACKFEED
+000.....	LABEL TOP
+0000.....	LEFT POSITION
038.....	WEB S.
075.....	MEDIA S.
058.....	RIBBON S.
092.....	MARK S.
092.....	MARK MED S.
000.....	MEDIA LED
000.....	RIBBON LED
000.....	MARK LED
DPCS.....	MODES ENABLED
.....	MODES DISABLED
832 8/MM FULL.....	RESOLUTION
.....	SOCKET 1 ID
.....	SOCKET 2 ID
V21.X.X.....	FIRMWARE
CUSTOMIZED.....	CONFIGURATION
1024k.....	MEMORY
NONE.....	B: MEMORY

FIRMWARE IN THIS PRINTER IS COPYRIGHTED

**Figure 3.2 CANCEL Key Test  
Sample Printout**

The configuration may be changed either temporarily (for specific label formats or ribbon and label stock), or permanently (by saving the new parameters in EEPROM Memory). Saving new parameters occurs whenever a Printer Calibration procedure is performed. Refer to the procedure in [“Configuration and Calibration.”](#)

## PAUSE Key Self Test

This self test is actually comprised of four individual test features.

1. The initial self test prints 15 labels at speed “A” then automatically PAUSES the printer. Each time the PAUSE key is pressed, an additional 15 labels print out.
2. While the printer is PAUSED, pressing the CANCEL key once alters the self test. Now each time the PAUSE key is pressed the printer prints 15 labels at speed “D” (“C” for the 300 dpi 105Se).
3. While the printer is PAUSED, pressing the CANCEL key a second time alters the self test again. Now, each time the PAUSE key is pressed the printer prints 50 labels at speed “A.”
4. While the printer is PAUSED, pressing the CANCEL key once alters the self test a third time. Now, each time the PAUSE key is pressed the printer prints 50 labels at speed “D” (“C” for the 300 dpi 105Se).

**Note:** On printers with either the rewind or peel option installed, the Peel Mode is activated during the first half (steps 1–4) of the PAUSE Key Self Test. On printers with a rewind option, the rewind plate must be removed for proper function of the peel sensors during the test. The first label to print will say, “PEEL OPTION INSTALLED”. Each label must be manually removed from the sensor path before the next label will print. Steps 1–4 will then be repeated in Rewind Mode.



**Figure 3.3 PAUSE Key Test Sample Printout**

This self test can be used to provide the test printouts required when making adjustments to the printer’s mechanical assemblies. See the sample printout in [Figure 3.3](#).

## FEED Key Self Test

The CANCEL Key Self Test should be performed before this self test. Information on the “Configuration” printout (CANCEL Key Self Test) can be used with the results of this self test to determine the best Darkness setting for a specific media/ribbon combination.

The FEED Key Self Test will print out at various Darkness settings above and below that of the Darkness value shown on the Configuration Label. Inspect these labels and determine which one has the best darkness setting for the application. This value can be entered into the printer by setting the Darkness during the configuration procedure.

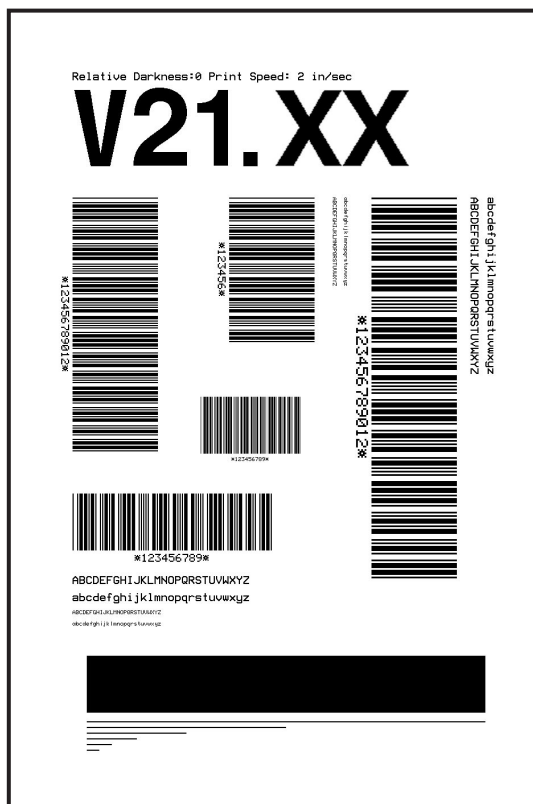


Figure 3.4 FEED Key Test Sample Printout

The value printed on that label is added to (plus) or subtracted from (minus) the “Darkness” value specified on the Configuration Label. The resulting numeric value (0 to 30) is the best darkness value for that specific media/ribbon combination.

Optionally, the Darkness value can be programmed into the ZPL II formats sent to the printer.



## FEED Key and PAUSE Key Self Test

Pressing these two keys at the same time, while turning the Power ON, temporarily resets the Printer Configuration to the factory default values. These values will be active until Power is turned OFF. **Whenever the printer is reset to factory defaults, a Media Calibration procedure must be performed immediately.**

## MODE Key Self Test

This test places the printer in the Communications Diagnostics Mode. In this mode, the printer prints the ASCII characters and their corresponding hexadecimal values for any data received from the host computer. A typical printout from this test is shown in Figure 3.5.

**Note:** This label will be inverted when printed.

```
^FS^F0394 . 25^AA
5E 46 53 5E 46 4F 33 39 34 2C 32 35 5E 41 41
N . 18 . 10^FDC0000
4E 2C 31 38 2C 31 30 5E 46 44 28 30 30 30 30
)999-9999^FS
29 39 39 39 2D 39 39 39 39 5E 46 53 0D 0A
^F00 . 50^AAN . 18 .
5E 46 4F 30 2C 35 30 5E 41 41 4E 2C 31 38 2C
10^FDCENTER STA
31 30 5E 46 44 43 45 4E 54 45 52 20 53 54 41
```

Figure 3.5 Results of Communications Diagnostic Test

## PAUSE Key and CANCEL Key Test

This test prints a maximum of 500 Head Test labels. Each label back-feeds prior to printing and feeds forward to the rest position after printing. A serialized number prints on each label. Press the PAUSE key or turn the printer power OFF to stop printing. The labels look like the one in [Figure 3.3](#) except that a serialized number will print on each label.

## FEED Key and CANCEL Key Test

This test prints seven pre-programmed label formats at different speeds. The printer automatically pauses after each format. The sequence of label formats is as follows:

Label Format	Quantity	Inches per second
Left Ribbon Wrinkle Test	20	D*
Right Ribbon Wrinkle Test	20	D*
C39 Wrinkle Test	20	D*
Left Ribbon Wrinkle Test	20	A
Right Ribbon Wrinkle Test	20	A
C39 Wrinkle Test	20	A
Usable Area Test	10	D*
Head Temperature Test	10	D*
Upper Smear Test	10	D*
Lower Smear Test	10	D*
Usable Area Test	10	A
Head Temperature Test	10	A
Upper Smear Test	10	A
Lower Smear Test	10	A

\* “C” for the 105Se with the 300 dots/inch printhead

## Extended Printer Diagnostics

Extended diagnostic tests are available. The maintenance manual, *Vol. 1: General Maintenance* (part # 38452L), provides the information needed to perform these additional tests.

## Sample ZPL II Label Formats

ZPL II<sup>®</sup> is Zebra Technologies Corporation's Zebra Programming Language II label design language. ZPL II lets you create a wide variety of labels from the simple to the very complex, including text, bar codes, and graphics.

This section contains three sample label formats for you to begin experimenting with. It is not intended as an introduction to ZPL II. To learn about ZPL II, send in the request card at the beginning of this book for a copy of the *ZPL II Programming Guide*.


For each format, do the following:

1. Save the file.
2. Copy the file to the printer.
  - Set-up the printer and turn the Power ON.
  - Use a text editing program (ex: Windows Write or DOS Editor) and type in the label format exactly as shown in the sample label format shown below.
  - Save the file in a directory for future use. Use the extension “.zpl”.
  - Copy the file to the Zebra S-Series Printer.


**Note:** Typically, computers running DOS use the “COPY” command to send a file to the Zebra printer. For example, if your file name is “format1.zpl” then type, “COPY FORMAT1.ZPL COM1”.

3. Compare your results with those shown. If your printout does not look like the one shown, confirm that the file you created is identical to the format shown, then repeat the printing procedure. If nothing prints, refer to [“Installation”](#) to make sure your system is set up correctly, otherwise refer to [“Troubleshooting.”](#)



## Format 1: Simple Text and a Barcode

Line #	Type this label format:	You'll get this printout:
1 2 3 4 5	<code>^XA</code> <code>^LH30,30</code> <code>^FO20,10^AD^FDZEBRA^FS</code> <code>^FO20,60^B3N,Y,20,N^FDAAA001^FS</code> <code>^XZ</code>	<p>ZEBRA</p> 
<p>Line #1: Indicates start of label format.            Line #2: Sets label home position (in dots) from the upper left-hand corner of the label.            Line #3: Sets field origin, selects font "D", defines field data as "ZEBRA".            Line #4: Sets field origin, selects bar code Code 39, sets barcode height at 20 dot rows, defines field data for bar code as "AAA001".            Line #5: End of label format.</p>		

## Format 2: Saving a Label Format As a Graphic Image

Line #	Type this label format:	You'll get this printout:
1 2 3 4 5 6 7 8 9	<code>^XA</code> <code>^LH30,30</code> <code>^FO20,10^AD^FDZEBRA^FS</code> <code>^FO20,60^B3N,Y,20,N^FDAAA001^FS</code> <code>^ISFORMAT2,N</code> <code>^XZ</code>  <code>^XA</code> <code>^ILFORMAT2</code> <code>^XZ</code>	<p>(Same as Format 1, but this format was also saved in the printer's memory as a graphic image named "FORMAT2".)</p> <p>ZEBRA</p> 
<p>Line #1-4: These commands were described in Format 1.            Line #5: Saves the format in the printer's memory as a graphic image named "FORMAT2", the "N" indicates "do not print after saving".            Line #6-7: (See Format 1)            Line #8: Load and print the graphic image saved as "FORMAT2".            Line #9: (See Format 1)</p>		

### Format 3: Using a Serialized Data Field

Line #	Type this label format:	You'll get this printout:
1	^XA	<p>ZEBRA</p>  <p>SERIAL NUMBER 00000000111</p> <hr/> <p><i>Ten labels should print. The first and last are shown here.</i></p> <hr/> <p>ZEBRA</p>  <p>SERIAL NUMBER 00000000120</p>
2	^LH30,30	
3	^FO20,10^AD^FDZEBRA^FS	
4	^FO20,60^B3,,40,^FDAAA001^FS	
5	^FO20,180^AF^SNSERIAL NUMBER 00000000111,1,Y^FS	
6	^PQ10	
7	^XZ	
<p>Line #1 - 3: These commands were described in Format 1.            Line #4: Defines field data for bar code as "AAA001".            Line #5: Defines serialized field, starting value of 111, increment by 1, insert leading zeros.            Line #6: Sets print quantity to 10            Line #7: (See Format 1)</p>		

# Configuration and Calibration

## Option Switches

These switches are located at the rear of the printer above the Signal Interface Cable Connection. See Figure 4.2.

In the tables on the following page, an “R” means the switch is OFF (positioned to the right), while an “L” means the switch is ON (positioned to the left). All switches are in the OFF position when the printer is shipped from the factory.

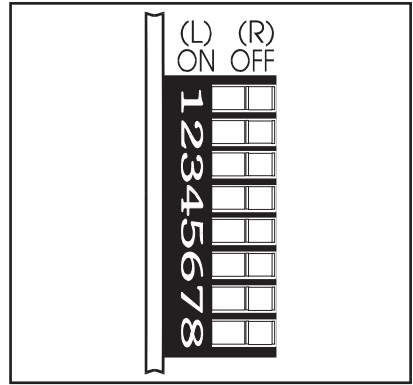


Figure 4.1 Option Switches

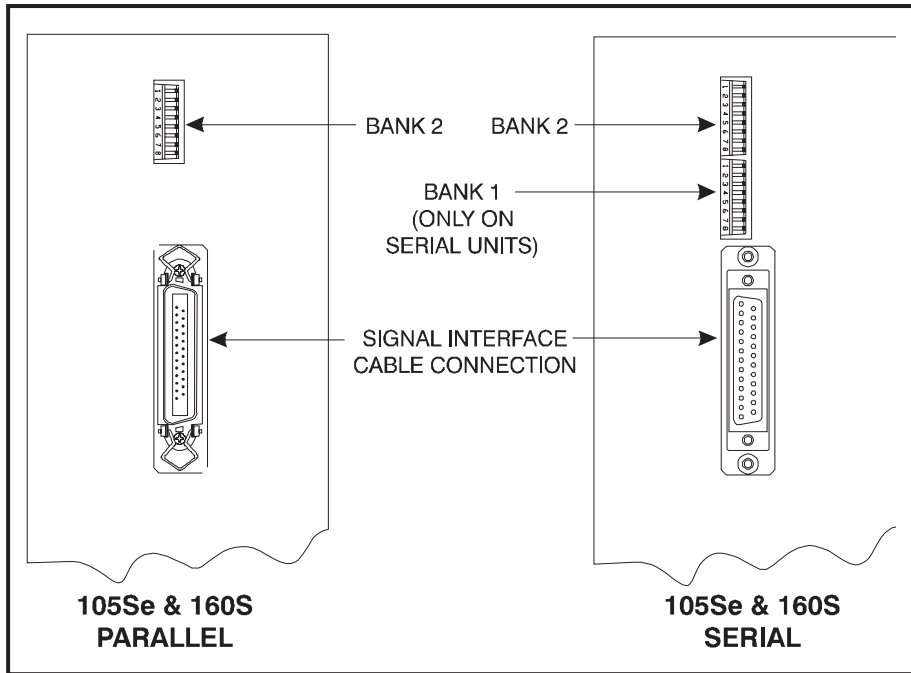


Figure 4.2 Location of Option Switches

## Bank 1 (For Serial Interface Printers Only)

The S-Series Printer, with the RS-232 Serial Interface, uses eight miniature switches located on the rear of the printer, above the Signal Interface Cable Connector. The ON/OFF positions of these switches establish some of the Printer Configuration Parameters. Bank 1 switches must be properly positioned to establish serial data communications with the host computer. Thereafter, the position of these switches should not be changed.

**Note:** Parallel-interface printers do not require these configuration parameters, therefore they have no Bank 1 switches.

If these switches are in the proper position to match the communication configuration of the host computer, and the printer is not receiving data, refer to [“Interconnections”](#) and make sure the correct interface cable is being used.

**Note:** The printer is fixed at 1 stop bit, so make sure that your host device is also set at 1 stop bit.

Bank 1 (Serial Interface Printers Only)	
Switch 3 2 1	Baud Rate
R R R	9600 baud
R R L	19200 baud
R L R	110 baud
R L L	300 baud
L R R	600 baud
L R L	1200 baud
L L R	2400 baud
L L L	4800 baud
Switch 4	Data Bits (Must be set to 8 Data Bits to use Code Page 850.)
R	7 Data bits
L	8 Data bits
Switch 6 5	Parity (If you choose 7 data bits, you must choose either even or odd parity.)
R R	Even parity
R L	Parity disabled
L R	Odd parity
L L	Parity disabled
Switch 7	Communication Handshake Control
R	XON/XOFF control
L	DTR/DSR control
Switch 8	Error Detection Protocol
R	No error detection
L	Error detection active

**Table 4.1**

## Bank 2

These switches can manually override any ZPL II commands that affect print mode, media mode, and media type. They can also override settings established during the calibration procedure. Reasons why you might want to use these override switches:

Bank 2	
Switch 3 2 1	Print Mode
R R L	Cutter
R L L	Tear-Off
L R L	Peel-Off
L L L	Rewind
- - R	Override is disabled
Switch 6 5 4	Media Mode
R R L	Black-mark sensing mode
R L L	Transmissive sensing mode with non-continuous media (detects a web/notch)
L L L	Transmissive sensing mode with continuous media
- - R	Override is disabled
Switch 8 7	Media Type
R L	Thermal transfer
L L	Direct thermal
- R	Override is disabled

**Table 4.2**

- Troubleshooting. By using these switches, you know beyond a doubt what operating mode your printer is in.
- Lets you use a single ZPL II label format for many different printers—without worrying if the format contains a mode command that is inappropriate for your printer configuration.
- Some third-party label design software packages work better if these switches control the mode.

If you do not want to override ZPL II or the calibration settings, disable one or more of the override options by setting switches 1, 4, and/or 7 to the R (OFF) position and turning the power ON. With these disabled, the printer will require ZPL II commands and/or re-calibration to set print mode, media mode, and/or media type.

To override, set the switches to one of the modes shown in the table. If you are in the process of printing, this change takes effect on the next label printed. If you change the switches from active to disabled after printer power-up, the printer remains in the current mode until a ZPL II command or re-calibration changes the mode.

**105Se Note:** Switch 5 must not be positioned to the right unless the printer is equipped with the optional black mark sensor.



## Configuration Mode

The Configuration Mode allows you to fine-tune the internal printer configuration settings for your application. In this mode, you can change the following parameters:

- Printing darkness
- Rest position of the media with respect to the “web” or “interlabel gap”
- Position of printing relative to the top of the label
- Media and Ribbon Sensor values
- Label length
- Printing method
- Media type (continuous or non-continuous)

You can get a printout of the printer configuration (the values for each of these parameters) at any time by performing the [CANCEL Key Self Test](#) (see “Operation”).

If it is ever necessary to reset the printer configuration to the factory defaults, refer to the [“FEED Key and PAUSE Key” Self Test](#) description in “Operation.”

The *ZPL II Programming Guide* contains information on instructions that may be sent to the printer to disable the MODE key and set specific label format values for each of these parameters. If you are not using ZPL II, refer to the instructions provided with your software package to determine if you also have this capability.

## Calibration

**IMPORTANT:** Perform the Calibration Procedure when media and ribbon are first installed and each time a different type of media or ribbon is installed.

During this procedure, the printer automatically determines the media type, label length, media and ribbon sensor settings, and printing method. Media type is determined by sensing either continuous or non-continuous media as blank labels move through the printer. If non-continuous media is sensed, Label Length is also calibrated. If ribbon is sensed, the Thermal Transfer Print Method is configured. If no ribbon is present, the Direct Thermal Print Method is configured.

The results of this calibration are stored in the printer's memory. These parameters will remain in effect until the next calibration is performed. The Printer Configuration Printout, which prints when the CANCEL Key Self Test is performed, lists these results as well as other printer parameters.

**Note:** If the printer is in the Peel-Off Mode, the operator must “catch” the labels as they are peeled away from the backing during this procedure.

1. Load media and ribbon (if used). Make sure the Media Sensor is properly positioned (see [“Adjustments”](#)).

**IMPORTANT:** To use the Black-Mark Sensing Mode, make sure you set the Bank 2 DIP switches appropriately (see [page 4-3](#)).

2. Turn the power switch ON. When the Power ON Self Test is complete, the POWER, PAUSE, and PAPER/RIBBON lights will be ON.
3. Press the MODE key three times briefly. PAUSE and CALIBRATE lights turn ON.
4. Press UP (FEED Key) to calibrate. The printer feeds some media. The MODE lights will flash ON and OFF to indicate that the settings have been saved in memory.
5. Press PAUSE to exit PAUSE mode. PAUSE light turns OFF.

## *Adjusting the Print Darkness*

This procedure sets the darkness of the printing on the label. Use the lowest setting which provides the necessary print quality.

1. Press the MODE key. PAUSE and DARKEN lights turn ON.
2. Press UP or DOWN to adjust the current setting.
3. Press the MODE key three times. The MODE lights will flash ON and OFF to indicate that the settings have been saved in memory.
4. Press PAUSE to exit PAUSE mode. PAUSE light turns OFF.

## *Adjusting the Media Rest Position*

This procedure sets the end-of-label position relative to the Tear-Off Bar or Cutter.

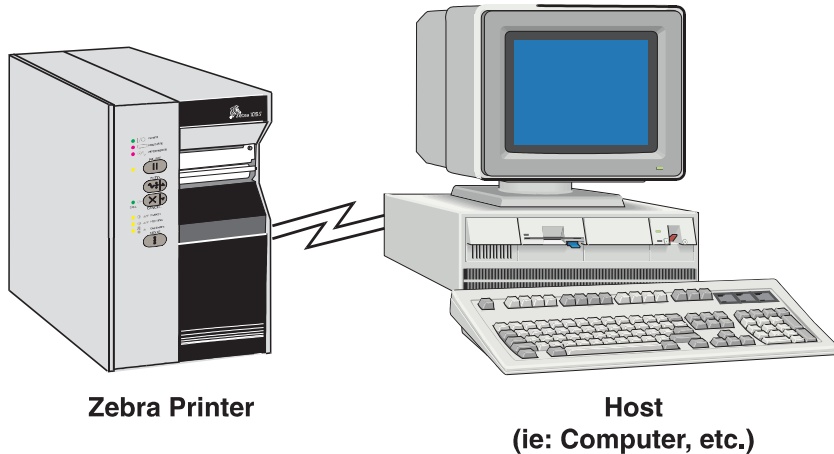
1. Press the MODE key twice briefly. PAUSE and POSITION lights turn ON.
2. Press UP or DOWN to adjust the current setting.
3. Press the MODE key twice briefly. The MODE lights will flash ON and OFF to indicate that the settings have been saved in memory.
4. Press PAUSE to exit PAUSE mode. PAUSE light turns OFF.

## *Adjusting the Position of the Top of the Label*

This procedure positions the printing on the label relative to the top edge of the label.

1. Press the MODE twice briefly then press and hold for about five seconds until the lights change. PAUSE and DARKEN and CALIBRATE lights turn ON.
2. Press UP or DOWN to adjust the current setting.
3. Press the MODE key twice briefly. The MODE lights will flash ON and OFF to indicate that the settings have been saved in memory.
4. Press PAUSE to exit PAUSE mode. PAUSE light turns OFF.

## System Components



**Figure 5.1 System Components**

## System Considerations

### *Communications Code*

The Zebra S-Series Printer sends and receives American Standard Code for Information Interchange (ASCII). This code consists of 128 characters (256 for Code Page 850) including upper and lower case letters, punctuation marks, and various control codes.

### *Interfaces*

The method of interfacing the Zebra S-Series Printer to a data source depends on the communication options installed in the printer. Depending on how the printer was ordered, the interface is either an RS-232 serial data port or a parallel port.

## Data Specifications

When communicating via the serial data port (RS-232), the baud rate, number of data bits, and the parity are user-selectable (see “[Configuration and Calibration](#)” for acceptable setting combinations). Parity only applies to data transmitted by the printer, since it ignores the parity of received data. The S-Series Printer is fixed at 1 stop bit, so make sure that your host is also set at 1 stop bit.

When communicating via the parallel port, the previously mentioned parameters are not considered.

## RS-232 Serial Data Port

The connections for the standard interface are made through the DB25S connector on the rear panel. For all RS-232 input and output signals, the S-Series Printer follows both the Electronics Industries Association’s (EIA) RS-232 and the Consultative Committee for International Telegraph and Telephone (CCITT) V.24 standard signal level specifications.

Pin No.	Description
1	Frame Ground for Cable Shield
2	TXD (Transmit Data) output from the printer
3	RXD (Receive Data) input to the printer
4	RTS (Request To Send) output from the printer
6	DSR (Data Set Ready) input to the printer
7	Signal Ground
20	DTR (Data Terminal Ready) output from the printer
Note:	<i>Pins 5, 8, 10-19, and 21-25 are not used and are unterminated.</i>

**Table 5.1 RS-232 Pinouts**

## *Hardware Control Signal Descriptions*

Request To Send (RTS) is a Control Signal from the S-Series Printer to the host computer. RTS is always in the ACTIVE condition (positive voltage) whenever the printer is powered ON.

Data Set Ready (DSR) is a control signal from the host computer to the printer. When DSR is in the ACTIVE condition (positive voltage), the printer can transmit status to the host. When CTS is in the INACTIVE condition (negative voltage), the printer will not transmit any data.

When DTR/DSR handshaking is selected, via DIP Switch #7 at the rear of the printer, the Data Terminal Ready (DTR) Control Signal output from the printer controls when the host computer may send data. DTR ACTIVE (Positive voltage), permits the host to send data. When the printer places DTR in the INACTIVE (negative voltage) state, the host must not send data.

**Note:** When XON/XOFF handshaking is selected, data flow is controlled by the ASCII Control Codes DC1 (XON) and DC3 (XOFF). The DTR Control lead will have no effect.

## *RS-232 Cabling Requirements*

The required cable must have a 25-pin “D” Type (DB25P) male connector on one end, which is plugged into the mating (DB25S) female connector located at the upper rear of the printer. Tighten the locking screws.

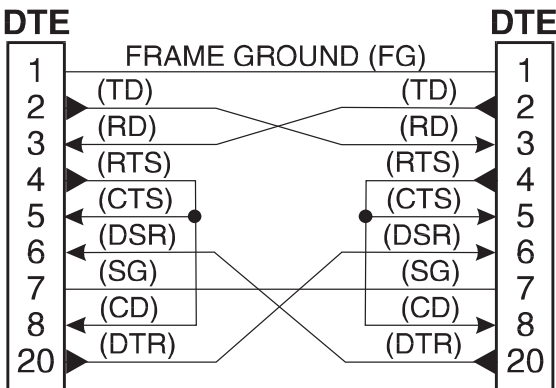
The other end of the Signal Interface Cable connects to an appropriate point at the host computer. This cable will be one of two types depending on the specific interface requirements. Refer to the following pages for information on the standard and null modem cables.

Data cables must be fully shielded and fitted with metal or metallized connector shells. Shielded cables and connectors are required to prevent radiation and reception of electrical noise.

To minimize electrical noise pickup in the cable:

- Keep data cables as short as possible.
- Do not bundle the data cables tightly with power cords.
- Do not tie data cables to power wire conduits.

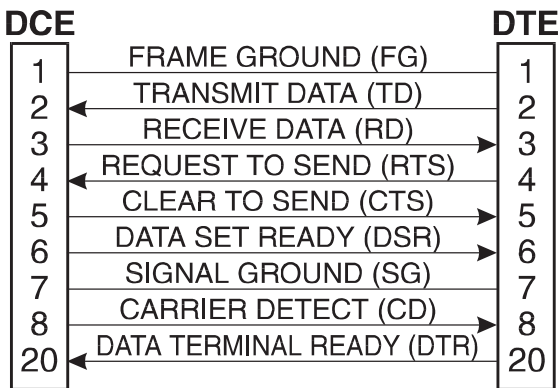
### Interconnect to DTE Devices



The printer is configured as Data Terminal Equipment (DTE). To connect the printer to other DTE devices (such as the serial port of a PC), use an RS-232 Null Modem (crossover) cable. Figure 5.2 illustrates the connections required for this cable.

Figure 5.2 DTE to DTE Connections

### Interconnect to DCE Devices



When the printer is connected via its RS-232 interface to Data Communication Equipment (DCE) such as a modem, use a standard RS-232 (straight-through) interface cable. Figure 5.3 illustrates the connections required for this cable.

Figure 5.3 DCE to DTE Connections

## Parallel Cabling Requirements

The required cable must have a standard 36-pin parallel connector on one end, which is plugged into the mating connector located at the upper rear of the printer. The parallel interface cable is connected using bail clips, instead of screws, in a similar position to that of the serial data cable.

The other end of the parallel interface cable connects to an appropriate point at the host computer.

Data cables must be fully shielded and fitted with metal or metallized connector shells. Shielded cables and connectors are required to prevent radiation and reception of electrical noise.

To minimize electrical noise pickup in the cable:

- Keep data cables as short as possible (maximum length: 10 ft.).
- Do not bundle the data cables tightly with power cords.
- Do not tie data cables to power wire conduits.

## Parallel Interface

The Parallel Interface provides a means of communication that is typically faster than the previously mentioned Serial Interface method. In this method, the bits of data which make up a character are sent all at one time over several wires in the cable, one bit per wire.

Data signals are defined as either HIGH or LOW, while Control Signals are either Active or Inactive. Some Control Signals are active HIGH while others are active LOW. The voltage levels which represent these conditions are:

<u>Data Signal</u>	<u>Voltage Level</u>
HIGH	+5 VDC
LOW	0 VDC



## Signal Descriptions

The following chart provides a description of each of the pins in the parallel connector. A standard parallel data cable will provide the required interconnection between the computer and the printer.

Parallel Connector Pin Assignments	
Pin No.	Description
1	The nStrobe printer input has internal 3.3 kW pull-up resistors to 5 V ( $I_{OL} = 1.5 \text{ mA}$ ) and is designed to receive a signal driven open collector $V_{OL} \leq 0.8 \text{ V}$ . This pin is a signal from the host computer. The nStrobe input is debounced on a LOW going edge to require an active width greater than 0.5 $\mu\text{s}$ before data is latched.
2 - 9	Data inputs have TTL input characteristics with internal 3.3 kW pullups and represent 1 TTL unit load or less. The Data inputs are positive logic with a HIGH voltage level corresponding to a logic 1. Pin 2 through Pin 9 = D0 through D7 respectively.
10	The nAck output is an active LOW pulse used to indicate termination. nAck is a driven open collector with a 3.3 kW internal pull-up. The output sinks 7 mA to a $V_{OL} \leq 0.4 \text{ V}$ .
11	The Busy output is active HIGH whenever the printer <b>cannot</b> accept data due to any normal or abnormal condition, including buffer overflow, head open, over temperature, and media error conditions. Busy is a driven open collector with a 3.3 kW internal pull-up. The output sinks 7 mA to a $V_{OL} \leq 0.4 \text{ V}$ .
12	The PError signal is active HIGH whenever the printer is out of media or ribbon.
13	The Select signal function is determined by an additional configuration option which becomes active when the port is present. In the default condition, Select is active HIGH whenever the parallel port is powered up and the parallel port is enabled. In the non-default condition, Select will go active LOW whenever the printer is printing.
14	nAutoFd (not connected)
15	Not defined
16	Logic Gnd
17	FRAME GROUND is at the same potential as Logic Gnd (pin 16).
18	FUSED 5 V - 1 A maximum.
19 - 30	SIGNAL GROUNDS are the Logic Grounds and Returns for all input and output signals.
31 - 35	NOT USED - These leads should be left unconnected.
36	NSelectIn (not connected)

# Preventive Maintenance

---

## Overview

This section contains preventive maintenance information for the Zebra S-Series Printer. These procedures may be performed by the operator.

## Cleaning

### *Exterior Surfaces*

The exterior surfaces of the printer may be cleaned as required by using a lint free cloth. Do not use harsh or abrasive cleaning agents or solvents. If necessary, a mild detergent solution or desktop cleaner may be used sparingly.

### *Interior*

Remove any accumulated dirt/lint from the interior of the printer using a soft bristle brush and/or vacuum cleaner. This area should be inspected after every four rolls of media.

AREA	METHOD	INTERVAL
Printhead	Isopropyl alcohol	After every roll of media (or 500 ft. of fanfold media) when printing direct thermal or after every roll of ribbon when printing in thermal transfer mode.
Platen Roller	Isopropyl alcohol	
Upper and Lower Media Sensors	Air blow	
Media Path	Isopropyl alcohol	
Ribbon Sensor	Air blow	
Peel/Tear Bar	Isopropyl alcohol	As needed.
Label Available Sensor	Air blow	Monthly.
Cutter Module	Isopropyl alcohol and/or air blow	As needed.

**Table 6.1 Cleaning Schedule**

## Printhead and Platen Roller

Inconsistent print quality, such as voids in the bar code or graphics, may indicate a dirty printhead. For optimum performance, Zebra recommends performing the cleaning procedure on [page 6-3](#) after every roll of ribbon (after every roll of media, for direct thermal printing).

**Note:** Label Available Sensors are shown for location purposes only. They are not standard on all printers.

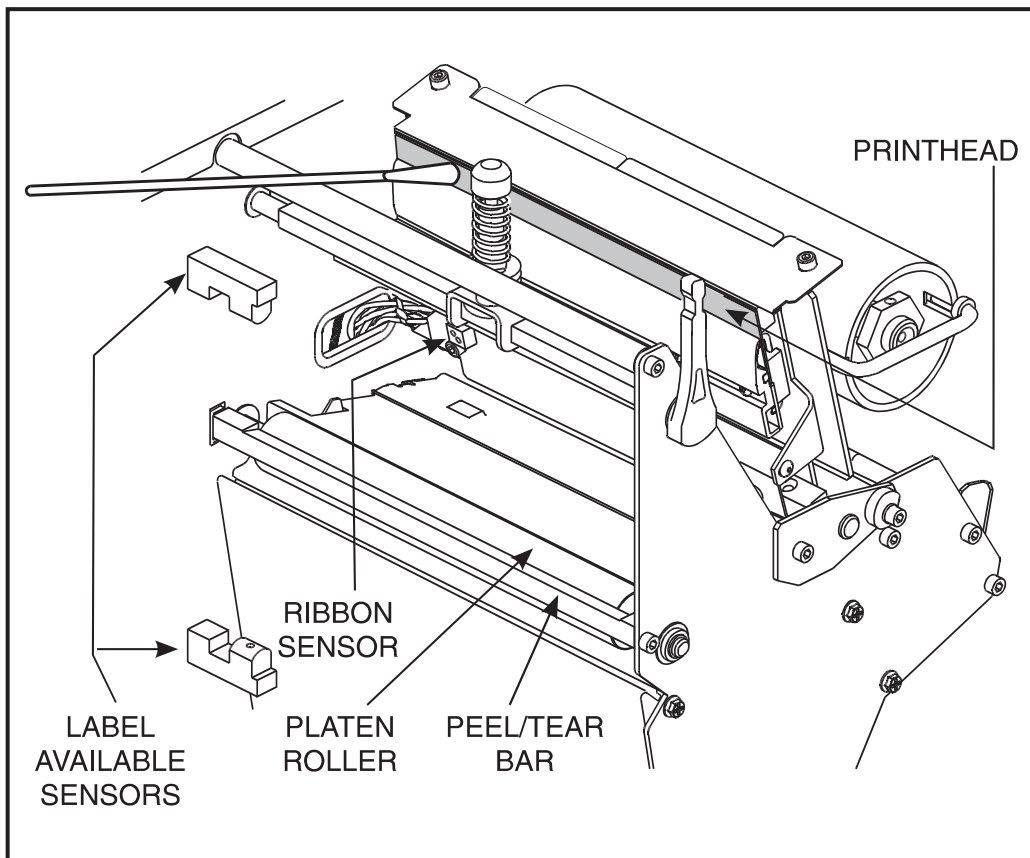


Figure 6.1 Printhead Cleaning (105Se shown)

It is not necessary to turn printer power OFF prior to cleaning. If power is turned OFF, all label formats, images, and parameter settings stored in the printer's formatting RAM will be lost. Permanent parameter settings stored in EEPROM will be retained. When power is turned back ON, it may be necessary to reload some items.

To clean the printhead and platen roller, open the media compartment door, refer to [Figure 6.1](#), and perform the following steps:

1. Open the printhead by moving the printhead handle to the OPEN position.
2. Remove the media and ribbon (if present).
3. Moisten an applicator tip with Zebra Technologies Corporation-recommended solvent and wipe the print elements from end to end. (The print elements form the gray/black strip just behind the chrome strip. See [Figure 6.1](#).) Allow a few seconds for the solvent to evaporate.
4. Rotate the platen roller and clean thoroughly with the solvent.
5. Brush/vacuum any accumulated paper lint and dust away from the rollers and the media and ribbon sensors.
6. Reload ribbon and/or media, close and latch the printhead, restore power (if necessary) and continue printing after the self test.

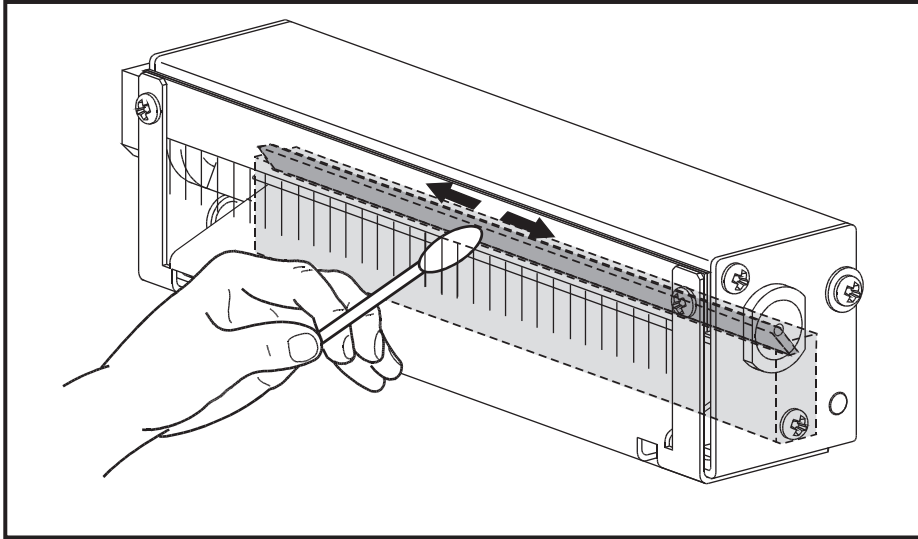
### *Media, Ribbon, and Label Available Sensors*

These sensors should be cleaned on a regular basis to ensure proper operation of the printer. To locate the position of these sensors, refer to [Figures 6-1, 7-2, and 7-3](#).

### *Cutter Module*

Periodically, the Cutter Module should be cleaned to remove paper dust and label residue. Cleaning the Cutter Module ensures that labels will be cut properly and not jam in the cutter mechanism. Refer to [Figure 6.2](#).

Clean the stationary cutter blade with a cotton swab moistened with isopropyl alcohol when it becomes gummed up with label adhesive or paper debris. If the cutter performs unsatisfactorily after it has been cleaned, refer to Volume 1 of the Maintenance Manual.



**Figure 6.2** Cleaning the Cutter Blade

## *Lubrication*

**CAUTION:** Some commercially available lubricants will damage the printer if used.

Lubrication of the Zebra S-Series Printer should be performed by a qualified service technician according to the directions provided in the Volume 1 of the *Maintenance Manual* (part # 38452L).

## Toggle Positioning

**Note:** The 105Se has one toggle, the 160S printer has two toggles.

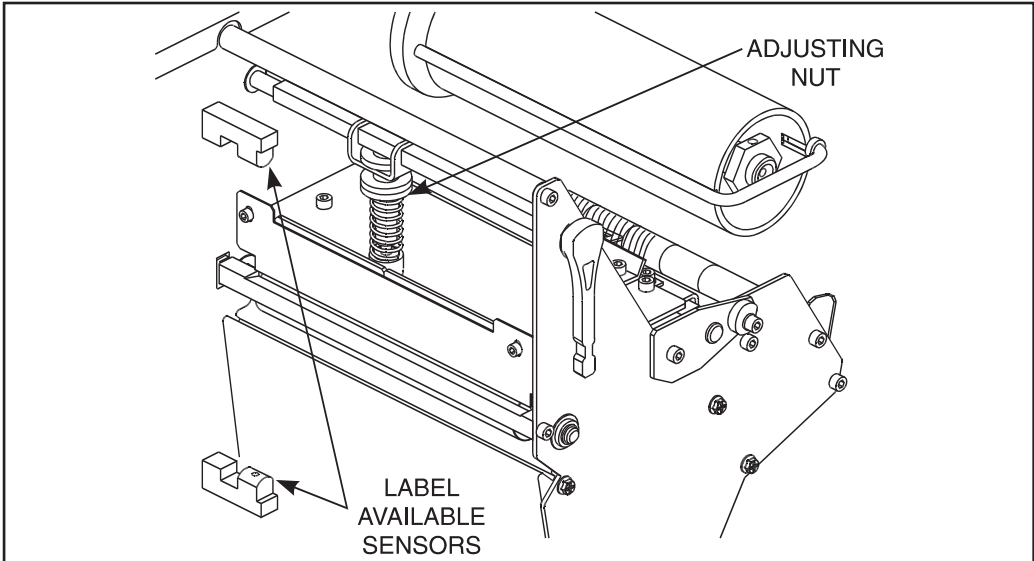
The toggle(s) should be positioned to provide even pressure on the media. Toggles are positioned by sliding them left or right to the desired location. On the 105Se, the single toggle should normally be positioned over the center of the media. If your printer has two toggles and you are using media too narrow to accommodate both toggles, position one toggle over the center of the media and decrease the pressure on the unused toggle.

## Printhead Pressure Adjustment

If printing is too light on one side, or if thick media is used, you may need to adjust the printhead pressure. Refer to [Figure 7.1](#) and follow the procedure below.

1. Perform a PAUSE Key Self Test.
2. Lower the Darkness Setting until the printing is gray.
3. Loosen the Toggle Position locking nut(s) located inside the “U” shaped bracket at the top of the toggle.
4. Slide toggle(s) in the direction of the light printing.
5. Using the knurled Adjusting Nuts on the shaft(s) of the toggle(s), increase or decrease spring pressure until the left and right edges of the printed area are equally dark.
6. Increase Darkness to optimum level for the media being used.
7. Retighten the Toggle Position locking nut(s).

**Note:** Printhead life can be maximized by using the lowest pressure that produces the desired print quality.



**Figure 7.1 Printhead Pressure Adjustment (105Se shown)**

## **Black Mark Media Sensor Position Adjustment**

This sensor position requires no adjustment or calibration by the user.

## **Transmissive Media Sensor Position Adjustment**

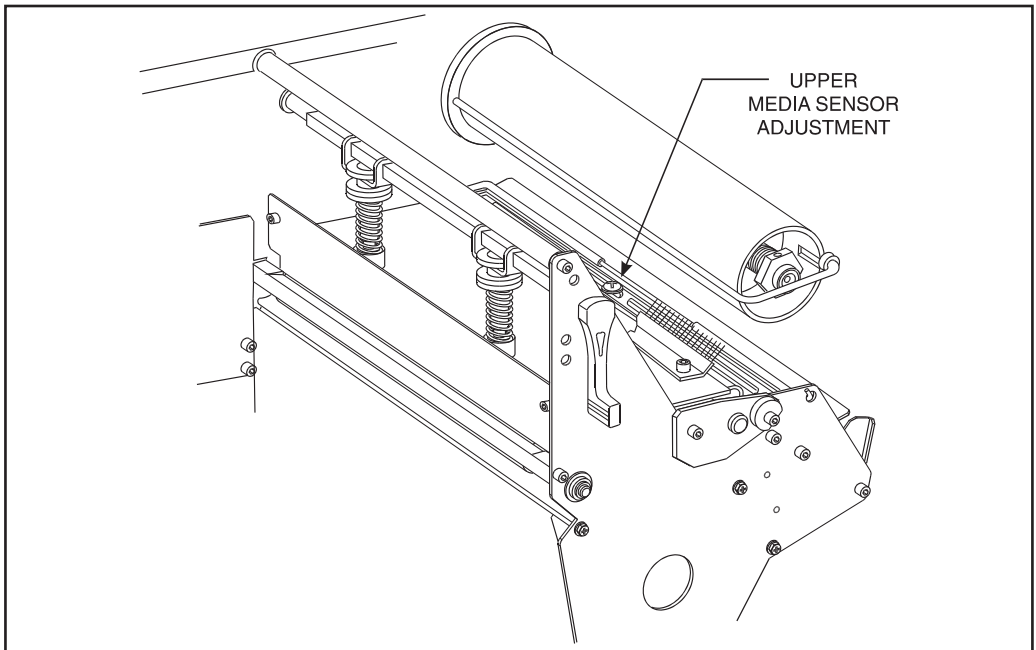
The transmissive media sensor senses either the “web” between labels or a hole or notch in the media to determine the length of the label or ticket. The factory-set position should be sufficient for any width label using media with a web. However, if position adjustments are needed, follow these procedures beginning with the upper sensor.

## Upper Transmissive Media Sensor Position Adjustment

To adjust the upper media sensor, refer to Figure 7.2 and follow these steps.

1. Remove the ribbon and locate the Upper Media Sensor.
2. Loosen the Phillips head screw.
3. Slide the upper sensor along the slot to the desired position. When using media that has a web between labels, position the media sensor anywhere along the web (except if you have labels with rounded corners, do not position the sensor where the rounded corners of the label might be detected). When using tag stock, position the upper sensor directly over the hole or notch.
4. Tighten the Phillips head screw.

**Note:** To adjust the upper section of the Transmissive Media Sensor for the outside half of the media width, call a service technician.



**Figure 7.2 Upper Media Sensor (105Se shown)**

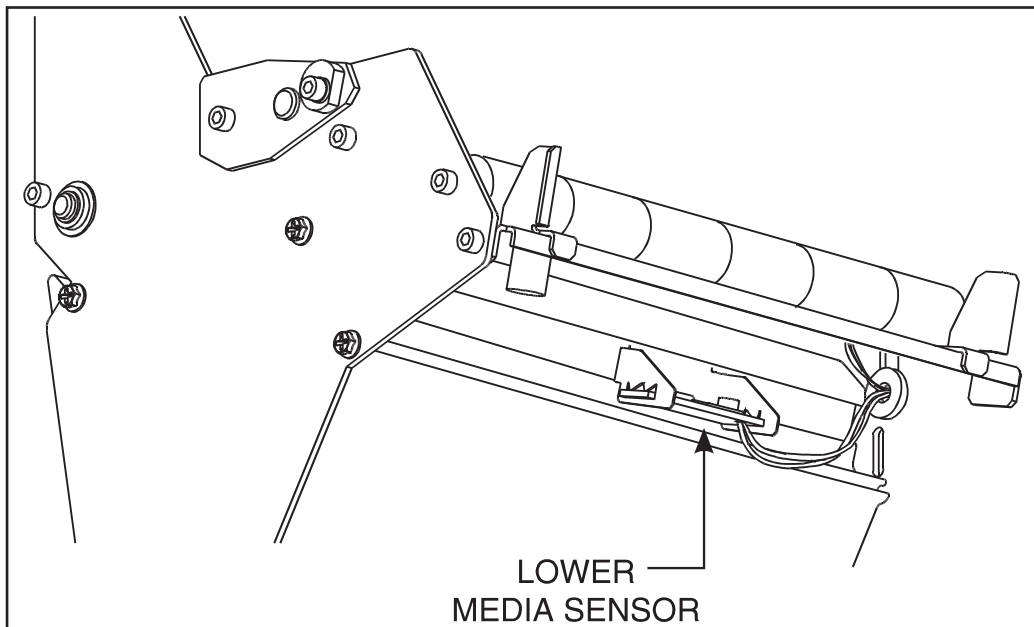


## Lower Transmissive Media Sensor Position Adjustment

To adjust the lower media sensor, follow these steps.

1. Locate the lower media sensor assembly (a spring clip holding a small printed circuit board) under the rear idler roller.
2. Position the sensor so that the two brass-colored infrared emitters are under the upper sensor by sliding it in its slot.
3. Gently pull wires out of the printer frame as required. (Wires should have a little slack.)

**Note:** If the sensor is being moved inward and a large loop of wire develops, remove the cover from the electronics side of the printer and gently pull the wires through. It is important that the wires be properly clamped so that they are not rubbed by any belts.



**Figure 7.3 Lower Transmissive Media Sensor Locations**

## Media and Ribbon Sensor Sensitivity Adjustment

**Note:** This adjustment is initially set by Zebra Technologies Corporation during final printer calibration. Under normal circumstances, further adjustments should not be necessary. The exception to this might be the use of media with exceptionally thick or thin backing, which could require re-adjustment of the Sensor Sensitivity.

This adjustment may need to be performed if the Paper/Ribbon light comes ON with (1) the media and ribbon properly installed for thermal transfer mode or (2) media only properly installed for the direct thermal mode.

The following procedure is used to perform the Media and Ribbon Sensor and Sensitivity Range Adjustment.

1. Turn the printer OFF.
2. Open the printhead.
3. Remove as many labels as needed to create at least 12 inches of blank backing material. Load the blank backing material under the printhead.

**Note:** Be sure that blank backing material is positioned between the upper and lower Media Sensors.

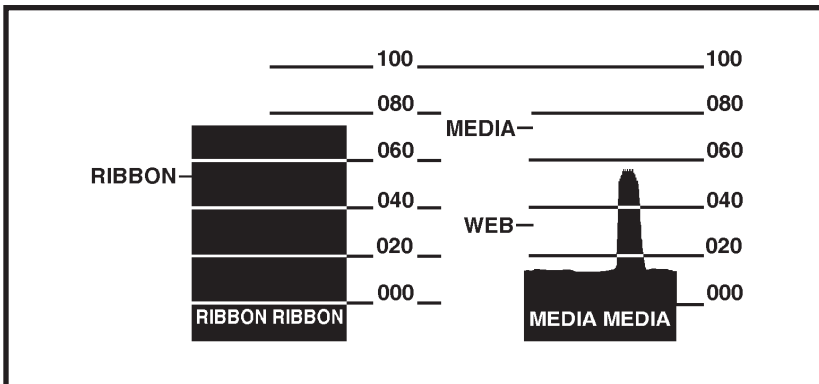
4. Remove the ribbon. (Sliding it as far from the printer wall as possible will have the same effect as removing it.)
5. Close the printhead.
6. Hold the PAUSE, FEED, and CANCEL keys depressed while turning the printer ON. Once the printer is ON, release the keys.
7. The following two sets of lights will begin flickering, signifying that the adjustment has been made.
  - The PRINTHEAD and PAPER/RIBBON lights
  - The DARKEN and POSITION lights

**Note:** If only one pair of lights is flickering, it indicates that the adjustment was not successful. Go back to step 1 and start over.

8. Open the printhead.
9. Pull the media out of the printer until a label is positioned under the printhead. Move the ribbon back to its normal position.

**Note:** Be sure that label is positioned between the upper and lower Media Sensors.

10. Close the printhead.
11. Press the MODE key to print a Media and Sensor Profile and save the new values (see Figure 7.4.).
12. Perform the Media Calibration procedure in [“Configuration and Calibration.”](#)



**Figure 7.4 Media Sensor Profile Sample Printout**

# Troubleshooting

This section contains troubleshooting charts used to localize and repair the printer when faults occur. The procedures called out in the ACTION column may be performed by the operator or by a service technician when indicated.

SYMPTOM	DIAGNOSIS	ACTION
All indicator lights never light.	No AC Power applied to the printer.	Ensure that the AC power cable is connected to a working voltage source.
	Faulty AC power fuse.	Refer to "Installation" for fuse replacement procedures.
	No voltage available from the internal power supply.	Call a service technician.
Printer locks up when running Power-On Self Test.	An improper configuration was set.	Reload factory defaults. Then, set correct parameters. See "Operation."
POWER light ON, other lights all OFF or all ON and the printer locks up.	ROM CRC test has failed.	Call a service technician.
CALIBRATE light is OFF but all other lights are ON.	Dynamic RAM failed.	Call a service technician.
CALIBRATE light and POSITION light OFF but all other lights ON.	FONT ROM error.	Call a service technician.
PRINthead light is ON, printing continues.	Printhead under-temperature condition.	Wait until printhead warms up. If condition persists and print quality is affected, move printer to a warmer environment. If print quality is acceptable, no action is required.
Printer stops. PAUSE light and PAPER/RIBBON light both ON.	Media incorrectly loaded or not loaded.	Load media correctly. See <i>Media Loading</i> in "Installation."
	Misadjusted Media Sensor.	Check position and sensitivity of Media Sensor and/or calibrate media. See "Adjustments" and "Configuration and Calibration."
	Media not calibrated.	

<b>SYMPTOM</b>	<b>DIAGNOSIS</b>	<b>ACTION</b>
Printer stops. PAUSE light ON and PAPER/ RIBBON light FLASHING.	Ribbon incorrectly loaded or not loaded.	Load ribbon correctly. See <i>Ribbon Loading</i> in “Installation.”
	Malfunctioning Ribbon Sensor.	Call a service technician.
Printer stops. PAUSE light ON and PRINTHEAD light FLASHING.	Printhead is not fully closed.	Close printhead completely.
	Printhead Open Sensor not detecting its position flag.	Call a service technician.
Printer stops. PAUSE light and PRINTHEAD light both ON.	Printhead element is overheated (105Se or 160S).	Printer resumes printing when the printhead element cools. If condition persists, move printer to a cooler environment.
	Power supply is overheated (105Se or 160S).	Printer resumes printing when the power supply cools. If condition persists, move printer to a cooler environment.
Dots missing in printed area of label.	Printhead element going bad.	Call a service technician.
Loss of printing registration on labels.  For Peel-Off Mode.	Possible media sensor or calibration problem.	Adjust media sensor position or calibrate media. Call a service technician if necessary.
	Printer set for non-continuous media, but continuous media loaded.	Set printer for correct media. See “Installation.”
	Improperly adjusted Media Edge Guides.	Refer to “Installation.”
Excessive vertical drift in top-of-form registration.	Incorrect media loading.	See <i>Media Loading</i> in “Installation.”
Light vertical lines running through all labels.	Dirty head or ribbon rollers.	See <i>Printhead Cleaning</i> in “Preventive Maintenance.”
	Defective printhead elements.	Call a service technician.
Light printing or no printing on the left or right side of the label.	Printhead needs balancing.	Adjust toggle pressure and/or position.
Short printed lines at 45° to label edge on left or right side of label.	Too much printhead pressure.	Adjust toggle pressure and/or position.
Fine gray lines on blank labels at angles.	Wrinkled ribbon.	See <i>Wrinkled Ribbon</i> in this table.

<b>SYMPTOM</b>	<b>DIAGNOSIS</b>	<b>ACTION</b>
Truncated print, no print, or FEED button operates incorrectly while using non-continuous media.	Media or ribbon improperly loaded.	See <i>Media Loading</i> and <i>Ribbon Loading</i> instructions in “Installation.”
Long tracks of missing print on several labels.	Wrinkled ribbon.	See <i>Wrinkled Ribbon</i> in this table.
	Print element damaged.	Call a service technician.
In Peel-Off Mode, skewed or stuck labels.	Glue material from back of labels causing media movement problems.	Refer to “Preventive Maintenance” and perform maintenance and cleaning of the printer.
	Media and backing not properly aligned in printer.	Refer to “Installation.”
Wrinkled ribbon.	Ribbon fed through machine incorrectly.	See <i>Ribbon Loading</i> in “Installation.”
	Incorrect Darkness setting.	Set to the lowest value needed for good print quality.
	Incorrect printhead position or pressure.	Adjust toggle pressure and/or position.
	Media not feeding properly; it is walking from side to side.	Make sure the media is snug by adjusting the media guides.
	Continuing symptoms.	Call a service technician.
Continued wrinkled ribbon.	Strip plate needs adjusting.	Call a service technician.
Misregistration and misprint of 1 to 3 labels.	Media was pulled when motor was not moving.	Enter Calibrate Mode and recalibrate.
	Incorrect Media Sensor position.	See the media sensor position adjustments in “Adjustments.”
	Media or ribbon improperly loaded.	See <i>Media</i> and <i>Ribbon Loading</i> in “Installation.”
	Incorrect Media Sensor position or sensitivity.	See “Configuration and Calibration.”
Changes in parameter settings did not take effect.	Parameters are set or saved incorrectly.	Reload the factory defaults. Refer to “Operation” and calibrate the printer. Then, cycle the power ON/OFF Switch.
	If problem continues, there may be a problem on the main logic board.	Call a service technician.

SYMPTOM	DIAGNOSIS	ACTION
ZPL II was sent to printer, but not recognized. The DATA light remains OFF.	Communications parameters or DIP switches are set incorrectly.	See “Operation” and perform MODE Key Self Test. Check for format or overrun errors. Reset Communication parameters if needed.
	Prefix and delimiter characters set in printer configuration do not match the ones sent in the ZPL II label formats.	Set the characters in the printer to match ZPL II format. Check Configuration Label for correct characters. If problem continues, check the ZPL II format for changed <b>^CC</b> , <b>^CT</b> , and <b>^CD</b> instructions.
Printer does not operate in the mode specified in ZPL II or by calibration	Bank 2 DIP switches set to override ZPL II and calibration.	Check Bank 2 DIP switch settings.
Printer does not feed media with black marks correctly.	Printer not set up correctly.	See “Configuration and Calibration” — recalibrate printer. See “Configuration and Calibration” to check Bank 2 DIP switch settings.
	Sensor is broken. (No red light is visible when looking through the front of the printer with the printhead open.)	Call a service technician.
In Cutter Mode, skewed or stuck labels.	Cutter is dirty.	Follow cutter module cleaning procedure in “Preventive Maintenance.”
The cutter is not cutting labels cleanly.	Cutter is dirty.	Follow cutter module cleaning procedure in “Preventive Maintenance.”
	Cutter blades are dull.	Replace the Cutter Module.
Labels jamming in cutter, or labels are being cut more than once.	Cutter is dirty.	Follow cutter module cleaning procedure in “Preventive Maintenance.”
	Label length is too short.	Increase label length.

SYMPTOM	DIAGNOSIS	ACTION
<b>For printers with the Cutter Option installed:</b> Printing stops. PAPER/RIBBON, PAUSE, and CANCEL LEDs on.	Media jammed in Cutter.	Remove media, clean Cutter Module.
	Connecting cable not connected to Cutter Module.	Plug cable into Cutter Module.
	Cutter Module is dirty.	Clean Cutter Module.
	End of the media is not positioned correctly on top of the platen.	Re-position media so that the end is on top of the platen.





## Peel-Off

Your printer may be equipped with the Peel-Off option. In the Peel-Off Mode, only the label backing rewinds onto the Rewind Spindle. The Peel/Tear Bar separates the label from the backing and the Label Available Sensor activates the PAUSE mode to allow the operator to remove a printed label before subsequent labels print.

*This option cannot be added to a printer equipped with the optional Cutter.*

## Cutter Module

Your printer may be factory equipped with a Cutter Module that cuts labels after they have been printed. In addition, an optional Cutter Catch Tray can be added to gather the labels once they have been cut.

## Media Rewind

Your printer may be equipped with a Media Rewind Option. This option supports **both** the Rewind and Peel-Off modes of operation.

In Rewind mode, both labels and backing material rewind internally onto a user-supplied three-inch core. A Rewind Bracket guides the media back to the Rewind Spindle after printing.

*This option cannot be added to a printer equipped with the optional Cutter.*

(See *Peel-Off Option* for Peel-Off mode of operation.)

## Fanfold Supply Bin

Your printer may be equipped with an optional internal Fanfold Supply Bin. It is used to load fanfold media within the media compartment, and it protects the media from environmental contaminants such as dust and dirt.

The Fanfold Media Supply Bin is fully adjustable. It accommodates media from 1.57" (40 mm) to 3.54" (90 mm) wide (7.17" [183 mm] wide for the 160S) and 3.5" (89 mm) to 8" (203mm) long. The maximum stack height for 8" long media is 4.5". Stack heights of 6.5" may be achieved with media less than 3.5" long.

The Fanfold Supply Bin may be installed in the field by the operator. To install the Fanfold Supply Bin, follow the instructions included with the option.

**Note:** The Fanfold Supply Bin, Peel-Off Option, and Rewind Option are mutually exclusive. The Fanfold Supply Bin may not be installed in S-Series Printers with the Peel-Off Option or the Rewind Option. Fanfold media may be used with the Rewind Spindle installed by using one of the external Fanfold supply access slots (at the bottom and rear of the printer).

## External ZebraNet™ (Ethernet) Interface

Allows you to connect your printer to your ethernet network. Available for both 10Base-2 and 10Base-T networks.

## Black Mark (Reflective) Sensor (*105Se Only*)

Utilizes continuous media with black marks printed on the back of the label liner. The Black Mark Sensor determines the label length and the top of the label by detecting the black mark (similar to the way a Transmissive Sensor detects the gap or notch).

This option is in addition to the standard transmissive sensor and is software- or switch-selectable.

## Optional Printer Fonts

The S-Series Printer can be optioned with character fonts in addition to those which are standard in the unit.

Only one additional font can be installed in the printer at a time. This installation should be performed by a service technician. Once installed, this font can be used in addition to the standard fonts available in the printer. Refer to the *ZPL II Programming Guide* for further application information.

Once an optional font is installed in the printer, the Configuration print-out from the CANCEL Key Self Test will indicate the font type.

The following optional scalable smooth fonts are presently available (each is supplied as a complete set of standard, bold, italic, and bold italic styles): CG Triumvirate™, CG Times™, CG Palacio™, Futura™, Univers®.

The following Bitmap Smooth Fonts (supplied in bold style only) are presently available:

CG Triumvirate™ Bold, CG Triumvirate™ Bold Condensed, Futura™ Bold, Univers® Bold, CG Times™ Bold and CG Palacio™ Bold (type sizes of 6 pt, 8 pt, 10 pt, 12 pt, 14 pt, 18 pt, 24 pt, 30 pt, 36 pt are available.)

Examples of these optional fonts can be found in [“Appendix D.”](#)

## 230 VAC Factory Setup

Your Zebra S-Series Printer will be factory set for 230 VAC operation if requested when the order is placed. If it is necessary to reconfigure your printer for operation at 115 VAC, see [“Installation.”](#)

## **512 KB DRAM Memory Expansion (*Not available for 105Se 300 dots/inch*)**

This option increases the printer's dynamic memory capacity from 0.5 MB to 1 MB. This supports longer label lengths and provides more capacity for downloadable fonts and large graphic image files. Extra memory may be installed at the factory or in the field.

## **12-Dot/mm and 6-Dot/mm Printhead (*105Se Only*)**

Optional 300 dot-per-inch and 152 dot-per-inch printhead densities satisfy specified requirements for printing UPC/EAN symbologies or high-density graphics and small, crisp text.

# Appendix A - 230 VAC Power Cord

## 230 VAC Power Cord

Depending on how the Zebra printer was ordered, a power cord may or may not be included when the printer is optioned for 230 VAC, 50/60 Hz operation.

If a power cord is not supplied, you will need to obtain one with the following specifications:

- The overall length must be less than 3.8 meters.
- It must be rated for at least 5 amps, 250 V.
- The CHASSIS GROUND (EARTH) MUST BE CONNECTED to assure safety and reduce electromagnetic interference. This is done by the third wire in the power cord.
- The plug cap should bear the certification mark of a known international safety organization (see Figure A.2).

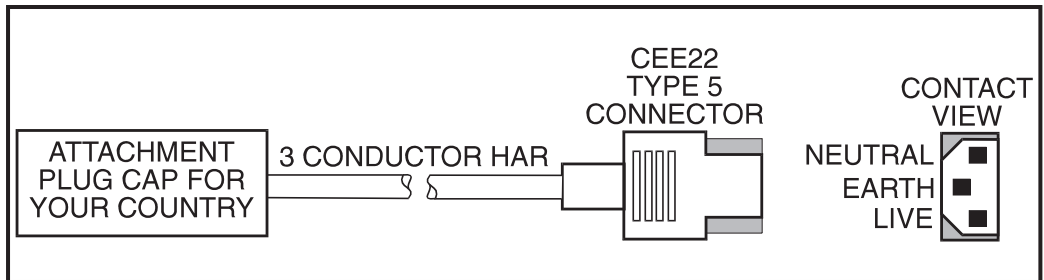


Figure A.1 AC Power Cord

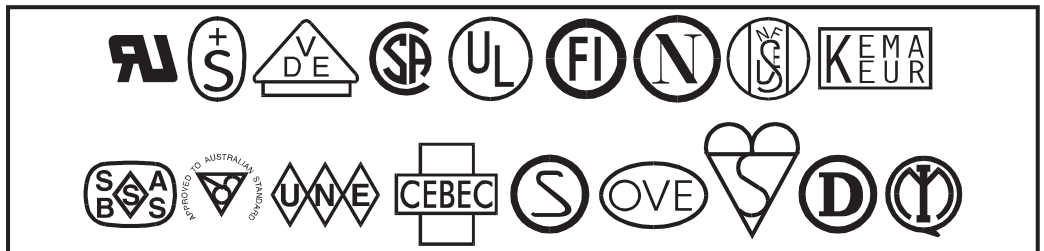
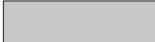


Figure A.2 International Safety Organizations



# Appendix B - ASCII Code Chart

HEX	CHAR	HEX	CHAR	HEX	CHAR	HEX	CHAR
00	NUL	20	space	40	@	60	`
01	SOH	21	!	41	A	61	a
02	STX	22	“	42	B	62	b
03	ETX	23	#	43	C	63	c
04	EOT	24	\$	44	D	64	d
05	ENQ	25	%	45	E	65	e
06	ACK	26	&	46	F	66	f
07	BEL	27	‘	47	G	67	g
08	BS	28	(	48	H	68	h
09	HT	29	)	49	I	69	i
0A	LF	2A	*	4A	J	6A	j
0B	VT	2B	+	4B	K	6B	k
0C	FF	2C	,	4C	L	6C	l
0D	CR	2D	-	4D	M	6D	m
0E	SO	2E	.	4E	N	6E	n
0F	SI	2F	/	4F	O	6F	o
10	DLE	30	0	50	P	70	p
11	DC1	31	1	51	Q	71	q
12	DC2	32	2	52	R	72	r
13	DC3	33	3	53	S	73	s
14	DC4	34	4	54	T	74	t
15	NAK	35	5	55	U	75	u
16	SYN	36	6	56	V	76	v
17	ETB	37	7	57	W	77	w
18	CAN	38	8	58	X	78	x
19	EM	39	9	59	Y	79	y
1A	SUB	3A	:	5A	Z	7A	z
1B	ESC	3B	;	5B	[	7B	{
1C	FS	3C	<	5C	\	7C	
1D	GS	3D	=	5D	]	7D	}
1E	RS	3E	>	5E	^	7E	~
1F	US	3F	?	5F	_	7F	DEL



Shaded values are NOT recommended for Command Prefix, Format Prefix, or Delimiter characters.





# Appendix C - Adjusting Bar Code Darkness

---

## Adjusting Darkness For “In-Spec” Bar Codes

All direct thermal and thermal transfer materials do not use the same darkness setting. The best way to check for the proper darkness is to use a bar code verifier that actually measures bars/spaces and will calculate the Print Contrast Signal (PCS) ratio. Without the assistance of a verifier, your eyes and/or the scanner to be used in the system may be used for picking the optimum darkness setting. What follows is a simple yet effective method for adjusting the darkness to print “in-spec” bar codes.

1. Load media according to the appropriate media loading and ribbon loading instructions in [“Installation.”](#) Ensure that the proper print method has been selected.
2. With power off, press and hold the FEED key.
3. Turn the printer power on, then release the FEED key. The printer begins printing test labels.
4. Print a label, then press the PAUSE key. The label will contain several bar codes as well as other printer information. Normal bar codes are printed in a horizontal format as they feed out of the printer. Rotated bar codes are printed in a vertical format.
5. Compare the test label printed to the bar codes in [Figure C.1](#). If the test label appears too dark or too light, increase or decrease the darkness setting accordingly.
6. Resume printing by pressing the PAUSE key again. Print a few labels at the new setting and verify that proper “in-spec” bar codes are being printed. Repeat steps 4, 5, and 6 until satisfied.
7. To stop printing test labels, press the PAUSE key, then press the CANCEL key.

**Too Dark** - Dark labels are fairly obvious. The normal bar code bars increase in size, and the openings in small alphanumeric characters may fill in with ink. It may be readable but not “in-spec”. Rotated bar code bars and spaces will run together.

**Slightly Dark** - Slightly dark labels are not as obvious. The normal bar code will be “in-spec”. Small character alphanumerics will be bold and could be slightly filled in. The rotated bar code spaces are small when compared to the “in-spec” code, possibly making the code unreadable.

**Slightly Light** - Slightly light labels are, in some cases, preferred to slightly dark for “in-spec” bar codes. Both normal and rotated bar codes will be “in-spec”, but small alphanumeric characters may not be complete.

**Too Light** - Light labels are obvious. Both normal and rotated bar codes have incomplete bars and spaces. Small alphanumeric characters are unreadable.

**In-Spec** - The “in-spec” bar code can only be confirmed by a verifier, but it should exhibit some very visible characteristics. The normal bar code will have complete, even bars and clear, distinct spaces. The rotated bar code will also have complete bars and clear distinct spaces. Although it may not look as good as a slightly dark bar code, it will be “in-spec”. In both normal and rotated styles, small alphanumeric characters will look complete.

# ROTATED BAR CODES



Figure C.1 Bar Code Examples



# Appendix D - Optional Printer Fonts

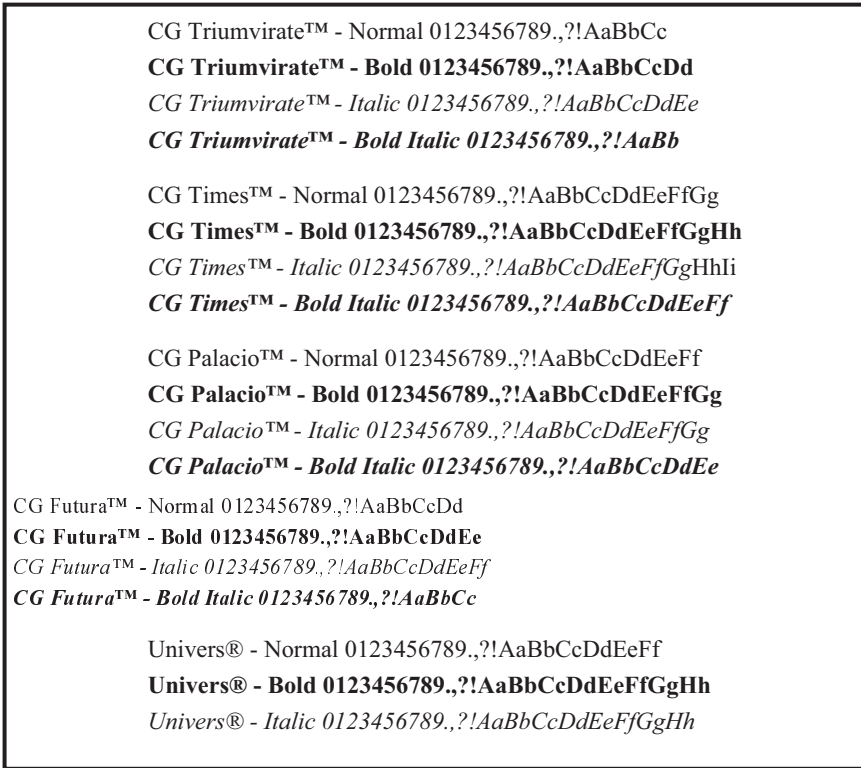
Your printer can be optioned with character fonts in addition to those that are standard in the unit. The following pages illustrate the Optional Fonts in each of the available styles. From time to time, additions may be made to the list of available fonts. Contact Zebra Technologies Corporation or your sales representative for further information.

Only one additional font can be installed in the printer at a time. This installation should be performed by a service technician. Once installed, this font can be used in addition to the standard fonts available in the printer. Refer to the *ZPL II Programming Guide* for further application information.

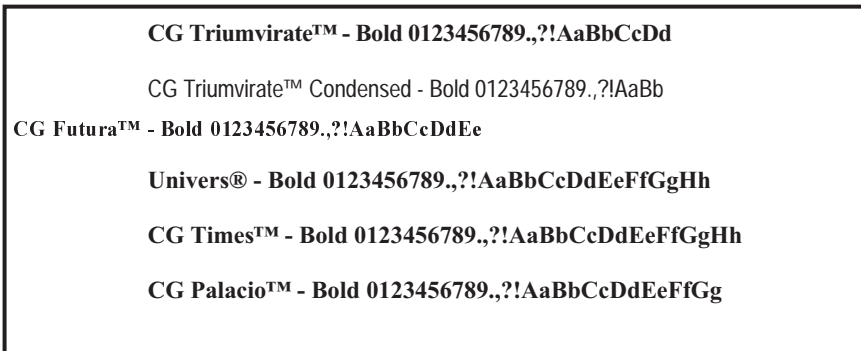
Once an optional font is installed in the printer, the configuration label printed during the CANCEL Key Self Test will indicate the font type as the “Socket 2 ID”.

Optional Printer Fonts Currently Available	
Scalable Smooth Fonts (each is supplied as a complete set of Normal, Bold, Italic, and Bold Italic styles)	Bitmap Smooth Fonts (supplied only in Bold). Type sizes: 6 pt, 8 pt, 10 pt, 12 pt, 14 pt, 18 pt, 24 pt.
CG Triumvirate™	CG Triumvirate™
—	CG Triumvirate™ Condensed*
CG Times™	CG Times™
CG Palacio™	CG Palacio™
Futura™	Futura™
Univers®	Univers®

\*When equipped with the Bitmap CG Triumvirate™ Bold Condensed font, the 105Se and 160S have the same font styles as the Stripe® S-300 printer.



**Figure D.1 Scalable Smooth Fonts (Optional)**



**Figure D.2 Bitmap Smooth Fonts (Optional)**

6 pt @ABCDEFGHIJKLMNO

8 pt @ABCDEFGHIJKLMNO

10 pt @ABCDEFGHIJKLMNO

12 pt @ABCDEFGHIJKLMNO

14 pt @ABCDEFGHIJKLMNO

18 pt @ABCDEFGHIJKLM

24 pt @ABCDEFGHIJ

30 pt @ABCDEFG

36 pt @ABCDEF

Figure D.3 Point Size Examples





- alphanumeric** Indicating letters, numerals, and characters such as punctuation marks.
- backfeed** The printer pulls the media and ribbon (if used) backward into the printer so that the beginning of the label to be printed is properly positioned behind the printhead. Backfeed occurs when you're operating the printer in tear-off or peel-off mode.
- bar code** A code by which alphanumeric characters can be represented by a series of adjacent stripes of different widths. Many different code schemes exist, such as the universal product code (UPC) or Code 39.
- black mark sensing** See "reflective media sensor".
- calibration (of a printer)** A process in which the printer determines some basic information needed to print accurately with a particular media/ribbon combination. To do this, the printer feeds some media and ribbon (if used) through the printer and senses whether to use the direct thermal or thermal transfer print method, whether continuous or non-continuous media will be used, and (if non-continuous media) the length of individual labels/tags.
- character set** The set of all letters, numerals, punctuation marks, and other characters that can be expressed by a particular barcode.
- check digit** A character added to a barcode symbol that indicates to the scanner that it has read the symbol correctly.
- continuous media** Label or tagstock that has no web (space between labels), notch, or gap to separate each label/tag, but rather the media is one long piece of material.
- core diameter** The inside diameter of the cardboard core at the center of a roll of media/ribbon.
- diagnostics** Information about what printer functions are not working. This information is used for troubleshooting.
- direct thermal printing** Printing in which direct thermal media is used. No ribbon is used. Instead, the media is coated with a substance which reacts to heat to produce an image.
- fanfold media** Media that comes folded in a rectangular stack, rather than on a roll.
- font** A complete set of alphanumeric characters in one style of type (ex: Times, Helvetica).
- ips "inches-per-second"** The speed at which the label or tag is printed. Zebra offers printers that can print from 2 ips to 12 ips.

**label** An adhesive-backed piece of paper, plastic, or other material on which information is printed.

**label available sensor** For printers equipped with the Peel-Off Option, this sensor detects a printed label waiting to be taken or “picked” by the operator. While it detects this label, the printer will not print additional labels. Once the label has been taken, printing resumes. Also called “take-label sensor”.

**label backing (label liner)** The material on which labels are affixed during manufacture and which is discarded or recycled by the end-users. Label backing (or liner) has a non-stick surface which allows the label to be easily removed by the end-user and placed in the desired location.

**mark sensing** See “reflective media sensor”.

**media** Material onto which data is printed by the printer. Types of media include: tagstock, continuous, fanfold, roll, etc.

**media hanger** The hanger that supports media rolls and provides consistent media feed to the printhead.

**non-volatile memory** Electronic memory that retains data even when power is removed.

**print speed** The speed at which printing occurs. For thermal transfer printers, this speed is expressed in terms of ips (inches per second). Zebra offers printers that can print from 2 ips to 12 ips.

**printhead wear** The degradation of the surface of the printhead and/or the print elements over time. Heat and abrasion can cause printhead wear. Therefore, to maximize the life of your printhead use the lowest print darkness setting (sometimes called “burn temperature” or “head temperature”) and the lowest printhead/toggle pressure necessary. Also, use ribbon that is as wide or wider than the media, to protect the printhead from the rougher media.

**reflective media sensor** A sensor that detects a black mark on the back of media by measuring the reflectivity of the media. This mark helps the printer determine label size and print registration.

**registration** Alignment of printing with respect to the top of a label/tag.

**ribbon** A band of inked material that is pressed by the printhead against the media to transfer an image onto the media, which in turn is pressed against the platen. A ribbon consists of a base film coated with wax or resin “ink”. Zebra ribbons also have a back coating that protects the printhead from damage. The ribbon transfers ink onto the media when heated by the printhead.

**ribbon wrinkle** A wrinkling of the ribbon caused by improper alignment of the strip plate and/or printhead pressure. This wrinkle can be seen just above the strip plate. Ribbon wrinkle can cause voids in the print and/or the spent ribbon to rewind unevenly. This is a condition that should be corrected by performing adjustment procedures.

**roll media** Media that comes supplied rolled up on a core (usually cardboard). Contrast this with fanfold media, which comes folded in a rectangular stack.

**supplies** Supplies is a general term for ribbon and media.

**tag** A type of media having no adhesive backing but featuring a hole or notch by which the tag can be hung on something. Usually tags are made of cardboard or other durable material.

**take label sensor** See “label available sensor”.

**thermal direct printing** See “direct thermal printing”.

**thermal transfer printing** A printing method in which the printhead heats an ink- or resin-coated ribbon against the media, causing the ink/resin to transfer onto the media. By selectively heating the ribbon, you can form an image on the media. See also “ribbon”.

**transmissive media sensor** This sensor is located behind the printhead to detect the presence of media and, for non-continuous media, the position of the web, hole, or notch that separates each label.

**void** A space where printing should have occurred but, due to some error condition, it did not occur. A void can cause a bar code symbol to be read incorrectly or not be read at all.



# Index

115 VAC Operation	2-3
12-Dot/mm and 6-Dot/mm Printhead	9-4
230 VAC Operation	2-3
230 VAC Power Cord	A-1

## A

Additional System Requirements	1-3
Adjustments	
Bar Code Darkness	C-1
Black Mark Media Sensor	7-2
Lower Transmissive Media Sensor	7-4
Media and Ribbon Sensor Sensitivity	7-5
Printhead Pressure	7-1
Upper Transmissive Media Sensor	7-3
ASCII Code Chart	B-1
ASCII Control Codes	5-3

## B

Bar Code Darkness	C-1
Baud Rate (Setting)	4-2
Burn Temperature (Adjusting)	4-6

## C

Calibration	4-4
Label Top	4-6
Media Rest	4-6
Print Darkness	4-6
CANCEL Key	3-4
CANCEL Key Self Test	3-9
Cleaning	
Cutter Module	6-3
Exterior Surfaces	6-1
Interior	6-1

Printhead and Platen Roller	6-2
Schedule	6-1
Sensors	6-3

Communications	
Diagnostic Test	3-12
Communications Capabilities	
Asynchronous Modems	1-1
Host Systems	1-1
Configuration Mode	4-4
Connection Recommendations and Cautions	1-4
Cutter Mode Media Loading	2-11

## D

Damage Report	2-1
Darkness (Adjusting)	4-6
Data Bits (Setting)	4-2
Data Signal Levels	5-5
Data Terminal Ready (DTR)	5-3
DCE Devices	5-4
DTE Devices	5-4
DTR/DSR Data Flow Control (Setting)	4-2

## E

Electrical Noise	5-4, 5-5
Error Detection (Setting)	4-2
Extended Printer Diagnostics	3-13

## F

Factory Defaults	4-4
Fanfold Media Loading	2-11
FCC Rules and Regulations	1-4
FEED Key	3-4
FEED Key and CANCEL Key Self Test	3-13

FEED Key and PAUSE Key Self Test	3-12
FEED Key Self Test	3-11
Front Panel Keys	
CANCEL Key	3-4
FEED Key	3-4
MODE Key	3-5
PAUSE Key	3-4
Front Panel Lights	
Calibrate	3-6
Darken	3-6
Data	3-6
Paper/Ribbon	3-6
Pause	3-6
Position	3-6
Power	3-6
Printhead	3-6

## I

Input and Output Signals (Standards Used)	
EIA RS-232 and CCITT V.24	5-2
Inspection	2-1
Interface Cables	
Crossover (Null Modem)	5-4
Straight Through	5-4
Interface Converter (When Required)	1-1
Interfaces	
Parallel	1-13
RS-232	1-13

## L

Label Available Sensor	3-3
Label Formats	3-14
Label Top (Adjusting)	4-6
Loading	
Media	2-8
Ribbon (105Se)	2-4
Ribbon (160S)	2-7

Lubrication	6-4
-------------	-----

## M

Media	
Fanfold	2-11
Loading	2-8
Roll	2-8
Media (Types to Use)	
Card Stock	1-4
Continuous Roll	1-4
Fanfold	1-4
Media Requirements	1-3
Media Rest Position (Adjusting)	4-6
Media Sensing Modes	
Black-Mark Sensing Mode	3-2
Transmissive Sensing Mode	3-2
Media Sensor Adjustments	
Lower	7-4
Upper	7-3
Media Sensor Sensitivity Adjustment	7-5
Media Transport Mechanism	1-2
Media Transport Modes	
Cutter	3-3
Peel-Off	3-3
Rewind	3-3
Tear-Off	3-2
Memory Option	9-4
MODE Key	3-5
MODE Key Self Test	3-12
Model Designation Label	1-1

## N

Null Modem	5-4
------------	-----

## O

Operating Modes	
Cutter	3-3
Peel-Off	3-3
Rewind	3-3
Tear-Off	3-2
Option Switches	4-1
Optional Printer Fonts	D-1
Options	
230 VAC Factory Setup	9-3
Black Mark Sensor	9-2
Cutter Module	9-1
Fanfold Media Bin	9-2
Fanfold Supply Bin	9-2
Fonts	9-3
Media Rewind	9-1
Memory	9-4
Peel-Off	9-1
Printheads	9-4
ZebraNet	9-2

## P

Parallel Cabling Requirements	5-5
Parallel Interface	5-5
Parity (Setting)	4-2
PAUSE Key	3-4
PAUSE Key and CANCEL Key Self Test	3-12
PAUSE Key Self Test	3-10
Peel-Off Media Loading	2-10
Power (AC)	
115 Operation	2-3
230 Operation	2-3
Fuse Replacement	2-3
Voltage Selection	2-2
Power On Self Test	3-7
Precautions	1-4
Print Darkness (Adjusting)	4-6

Print Mechanism	1-2
Print Quality	1-3
Reflectivity and Contrast	1-3
Printer Operating Modes	
Media Sensing	3-1
Media Transport	3-2
Printer Power Up	2-14
Printer Self Tests	
CANCEL Key	3-9
Communications Diagnostics	3-12
FEED Key	3-11
FEED Key and CANCEL Key	3-13
FEED Key and PAUSE Key	3-12
Introduction to	3-7
MODE Key	3-12
PAUSE Key	3-10
PAUSE Key and CANCEL Key	3-12
Printer Specifications (Complete Listing)	1-6
Printhead Life	
Media Abrasion	1-3
Printhead Pressure Adjustment	7-1
Printhead Wear (Guarding Against Premature)	1-3
Protocol Converter (When Required)	1-1

## R

Removing Used Ribbon	
105Se	2-12
160S	2-13
Repacking the Printer	
Caution Statements	1-5
Reporting Damage	2-1
Requirements	
Media and Ribbon	1-3
Reshipping	2-1
Rewind Mode Media Loading	2-10
Ribbon	
Lengths and Widths	1-2



Ribbon Loading	
105Se	2-4
160S	2-7
Ribbon Requirements	1-3
Ribbon Sensor Sensitivity Adjustment	7-5
Roll Media	
Cutter Mode	2-11
Peel-Off Mode	2-10
Rewind Mode	2-10
Tear-Off Mode	2-10
RS-232 Internal Connections	5-4
RS-232 Pinouts	5-2
<b>S</b>	
Sample Label Formats	3-14
Self Tests	
CANCEL Key	3-9
FEED Key	3-11
FEED Key and CANCEL Key	3-13
FEED Key and PAUSE Key	3-12
MODE Key	3-12
PAUSE Key	3-10
PAUSE Key and CANCEL Key	3-12
Power On	3-7
Sensor (Media) Position Adjustment	
Lower	7-4
Upper	7-3
Sensor Sensitivity Adjustment	7-5
Serial Communications Port	5-4
Serial Data Port	5-2
Shielded Cable (Use of)	1-4
Signal Descriptions	
Parallel Connector	5-6
Specifications (Complete Listing)	1-6
Site Requirements	2-4
Storage	2-1
Switch Settings	4-1
System Components	5-1

System Considerations	5-1
Communications Code (ASCII)	5-1
Data Specifications	5-2
Interfaces	5-1

## T

Tear/Peel-Off Bar	3-2
Tear-Off Mode Media Loading	2-10
Toggle Positioning	7-1
Transmissive Media Sensor Adjustment	
Upper	7-3
Lower	7-4
Troubleshooting	8-1

## U

Unpacking	2-1
-----------	-----

## V

Voltage Selection	2-2
-------------------	-----

## W

Warnings	1-4
----------	-----

## X

XON/XOFF Data Flow Control (Setting)	4-2
--------------------------------------	-----



## **Zebra Technologies Corporation**

333 Corporate Woods Parkway  
Vernon Hills, Illinois 60061.3109 U.S.A.  
Telephone +1 847.634.6700  
Facsimile +1 847.913.8766

## **Zebra Technologies Europe Limited**

Zebra House  
The Valley Centre, Gordon Road  
High Wycombe  
Buckinghamshire HP13 6EQ, UK  
Telephone +44 (0)1494 472872  
Facsimile +44 (0)1494 450103

## Free Manuals Download Website

<http://myh66.com>

<http://usermanuals.us>

<http://www.somanuals.com>

<http://www.4manuals.cc>

<http://www.manual-lib.com>

<http://www.404manual.com>

<http://www.luxmanual.com>

<http://aubethermostatmanual.com>

Golf course search by state

<http://golfingnear.com>

Email search by domain

<http://emailbydomain.com>

Auto manuals search

<http://auto.somanuals.com>

TV manuals search

<http://tv.somanuals.com>