



Zebra® QL and
QL Plus Series
Mobile Printer

User Guide



UMAN-QLS-001 rev. A
March, 2005

Table of Contents

Proprietary Statement	5
Introduction to the QL and QL Plus Series	7
Unpacking and Inspection	7
Reporting Damage	7
QL 220 Introduction	8
QL 320 Introduction	9
QL 420 Introduction	10
Getting Ready to Print	11
Battery	11
Installing the Battery	11
Charging the Battery	12
Model LI 72 Single Battery Charger	12
Model UCLI72-4 Quad Charger	13
Battery Safety	14
Charger Safety	15
Loading the Media	16
Installing the Media	16
Operator Controls	21
Standard Keypad	21
LCD Control Panel	23
Verify the Printer Is Working	26
Printing a Configuration Label	26
Connecting the Printer	26
Cable Communications	27
RS232C Communications	27
USB Communications (QL Plus units only)	27
Providing Strain Relief for Communications Cable	28
IR Communications	30
Wireless Communications with Bluetooth™ using ZBR3 Radio	31
Wireless Local Area Network (WLAN) Module Using CF Radio	33
QL 320/320 Plus Wireless Local Area Network Module Using PCMCIA Radio	35
QL 420/420 Plus Wireless Local Area Network Module Using PCMCIA Radio	37
Frequency Hopping Wireless Local Area Network Module Using PCMCIA Radio	39
WLAN Overview	41
Setting Up the Software	42
Using the Accessories	43
Belt Clip	43
Kickstand	43
Desk Stand	44
Adjustable Shoulder Strap	45
Carrying Strap	46
Preventive Maintenance	47

Extending Battery Life	47
Cleaning Instructions	48
QL220 Cleaning	49
QL 320 Cleaning	51
QL 420 Cleaning	53
Troubleshooting	54
Standard Control Panel	54
Optional LCD Control Panel	54
Troubleshooting Topics	55
Troubleshooting Tests	57
Printing a Configuration Label	57
Communications Diagnostics	57
Calling Technical Support	58
Specifications	64
Printing Specifications	64
Memory/Communications Specifications	64
Label Specifications	65
Font/Bar Code Specifications for QL Series	66
Font/Bar Code Specifications for QL Plus Series	66
Communications Ports	67
Physical/Environmental/Electrical Specifications	68
QL Series Accessories	72
Appendix A- Interface Cables	73
RS232 Cables	73
USB Cable (QL Plus Series only)	73
More Interface Cables	74
Appendix B- Media Supplies	77
Appendix C- Maintenance Supplies	78
Appendix D-Product Support	79
Battery Disposal	80
Product Disposal	80
Index	82
Patent Numbers	84

Proprietary Statements

This manual contains proprietary information of Zebra Technologies Corporation. It is intended solely for the information and use of parties operating and maintaining the equipment described herein. Such proprietary information may not be used, reproduced, or disclosed to any other parties for any other purpose without the expressed written permission of Zebra Technologies Corporation.

Product Improvements

Since continuous product improvement is a policy of Zebra Technologies Corporation, all specifications and signs are subject to change without notice.

FCC Compliance Statement

NOTE: This equipment has been tested and found to comply with the limits of a Class B digital device, pursuant to Part 15 of the FCC Rules. These limits are designed to provide reasonable protection against harmful interference in a residential installation. This equipment generates, uses and can radiate radio frequency energy and, if not installed and used in accordance with the instructions, may cause harmful interference to radio communications. However, there is no guarantee that interference will not occur in a particular installation. If this equipment does cause harmful interference to radio or television reception, which can be determined by turning the equipment off and on, the user is encouraged to try to correct the interference by one or more of the following measures:

- Reorient or relocate the receiving antenna.
- Increase the separation between the equipment and receiver.
- Connect the equipment into an outlet or circuit different from that to which the receiver is connected.
- Consult the dealer or an experienced radio/TV technician for help.

WARNING: Exposure to Radio Frequency radiation. To conform to FCC RF exposure requirements this device shall be used in accordance with the operating conditions and instructions listed in this manual. Note that there are several radio options available with this printer. Additional regulatory information is contained in later sections devoted to each radio individually.

NOTE: This unit was tested with shielded cables on the peripheral devices. Shielded cables must be used with the unit to insure compliance.

Changes or modifications to this unit not expressly approved by Zebra Technologies Corporation could void the user's authority to operate this equipment.

Canadian Compliance Statement

This Class B digital apparatus complies with Canadian ICES-003.

Cet appareil numérique de la classe B est conforme à la norme NMB-003 du Canada.

"IC:" before the equipment certification number signifies that the Industry Canada technical specifications were met. It does not guarantee that the certified product will operate to the user's satisfaction.

Agency Approvals and Regulatory Information

- Design certified by CSA
- Canadian STD RSS-210
- EN60950: 2000 Safety Standard
- C-Tick (Australia)
- FCC part 15
- EN55022:1998 European Immunity Standard
- NOM/NYCE (Mexico)
- EN55022:1998 Class B European Electromagnetic Radiation Standard

Liability Disclaimer

Inasmuch as every effort has been made to supply accurate information in this manual, Zebra Technologies Corporation is not liable for any erroneous information or omissions. Zebra Technologies Corporation reserves the right to correct any such errors and disclaims liability resulting therefrom.

No Liability for Consequential Damage

In no event shall Zebra Technologies Corporation or anyone else involved in the creation, production, or delivery of the accompanying product (including hardware and software) be liable for any damages whatsoever (including, without limitation, damages for loss of business profits, business interruption, loss of business information, or other pecuniary loss) arising out of the use of or the results of use of or inability to use such product, even if Zebra Technologies Corporation has been advised of the possibility of such damages. Because some states do not allow the exclusion of liability for consequential or incidental damages, the above limitation may not apply to you.

continued

Copyrights

The copyrights in this manual and the label print engine described therein are owned by Zebra Technologies Corporation. Unauthorized reproduction of this manual or the software in the label print engine may result in imprisonment of up to one year and fines of up to \$10,000 (17 U.S.C.506). Copyright violators may be subject to civil liability.

This product may contain ZPL®, ZPL II®, and ZebraLink™ programs; Element Energy Equalizer® Circuit; E3®; and AGFA fonts. Software © ZIH Corp. All rights reserved worldwide. ZebraLink and all product names and numbers are trademarks, and Zebra, the Zebra logo, ZPL, ZPL II, Element Energy Equalizer Circuit, and E3 Circuit are registered trademarks of ZIH Corp. All rights reserved worldwide.

CG Triumvirate is a trademark of AGFA Monotype Corporation. All rights reserved worldwide. CG Triumvirate™ font © AGFA Monotype Corporation. Intellifont® portion © AGFA Monotype Corporation. All rights reserved worldwide. UFST is a registered trademark of AGFA Monotype Corporation. All rights reserved worldwide.

All other brand names, product names, or trademarks belong to their respective holders.
©2005 ZIH Corp.

Introduction to the QL and QL Plus Series

Thank you for choosing one of our Zebra QL Series Mobile Printers. These rugged printers are sure to become productive and efficient additions to your workplace thanks to their innovative design. Because they're made by Zebra Technologies, you're assured of world-class support for all of your bar code printers, software, and supplies.

- This user's guide gives you the information you'll need to operate all QL Series printers.
- The QL Series uses the CPCL programming language. To create and print labels using the CPCL language, refer to the Mobile Printer Programming Guide (available on our Web site at: <http://www.zebra.com/manuals>) and our Label Vista™ label creation program.
- The QL Series offers optional interpreters for the EPL and ZPL II® (up to Version 30.8.4) Programming Languages. The printer must be equipped with the optional memory upgrade and an appropriate application in order to use this function. QL Plus Series printers have EPL and ZPL II emulation as a standard feature.

Manuals for the ZPL II or EPL2 label design programming languages are available on our Web site at:

<http://www.zebra.com/manuals>.

Unpacking and Inspection

Inspect the printer for possible shipping damage:

- Check all exterior surfaces for damage.
- Open the media cover (refer to "Loading the Media" in the Getting Ready to Print section) and inspect the media compartment for damage.

In case shipping is required, save the carton and all packing material.

Reporting Damage

If you discover shipping damage:

- Immediately notify and file a damage report with the shipping company. Zebra Technologies Corporation is not responsible for any damage incurred during shipment of the printer and will not cover the repair of this damage under its warranty policy.
- Keep the carton and all packing material for inspection.
- Notify your authorized Zebra re-seller.

QL 220 Introduction

Figure 1: QL 220 Overview

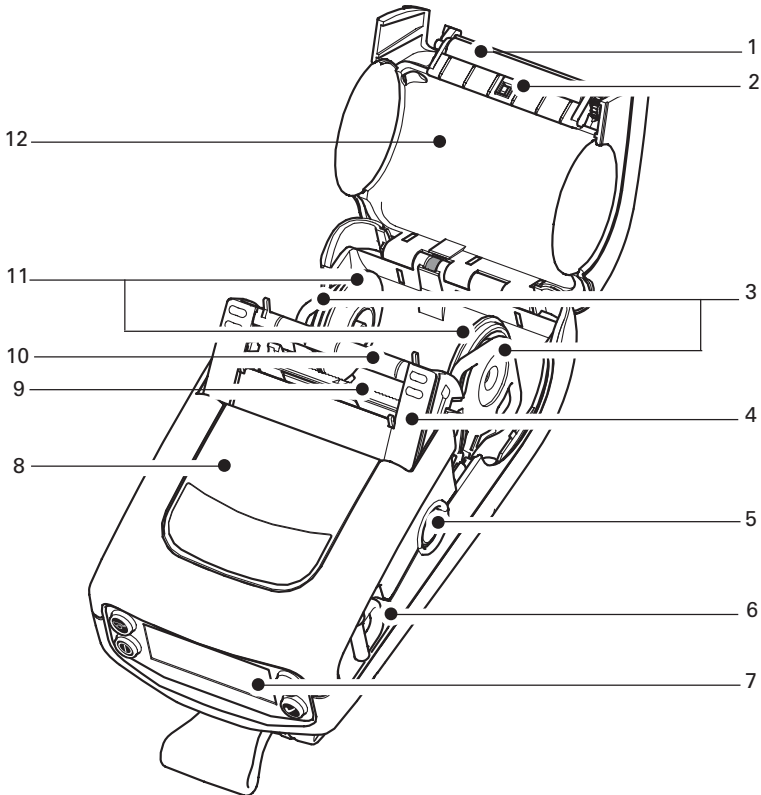

1. Platen Roller
2. Bar Sensor
3. Media Support
4. Latch
5. Latch Release Button
6. "D" Ring
7. Control Panel
8. QuickLink™ Module
9. Print Head
10. "E-Z Peel" Label Peeler
11. Media Support Disks
12. Media Cover
13. Belt Clip
14. Battery
15. Battery Charging Receptacle
16. RS232 Communications Port
17. USB Port (available on QL Plus Series only)

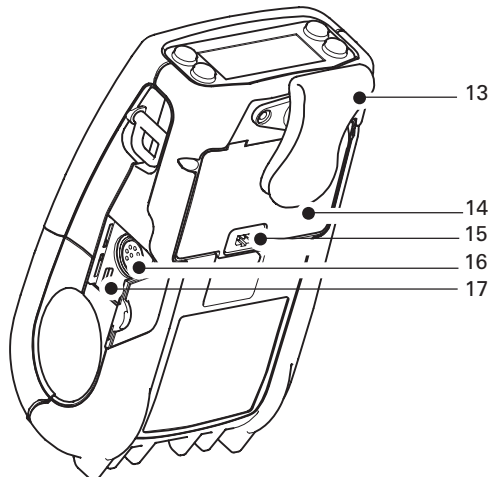

QL 320 Introduction

Figure 1B: QL 320 Overview

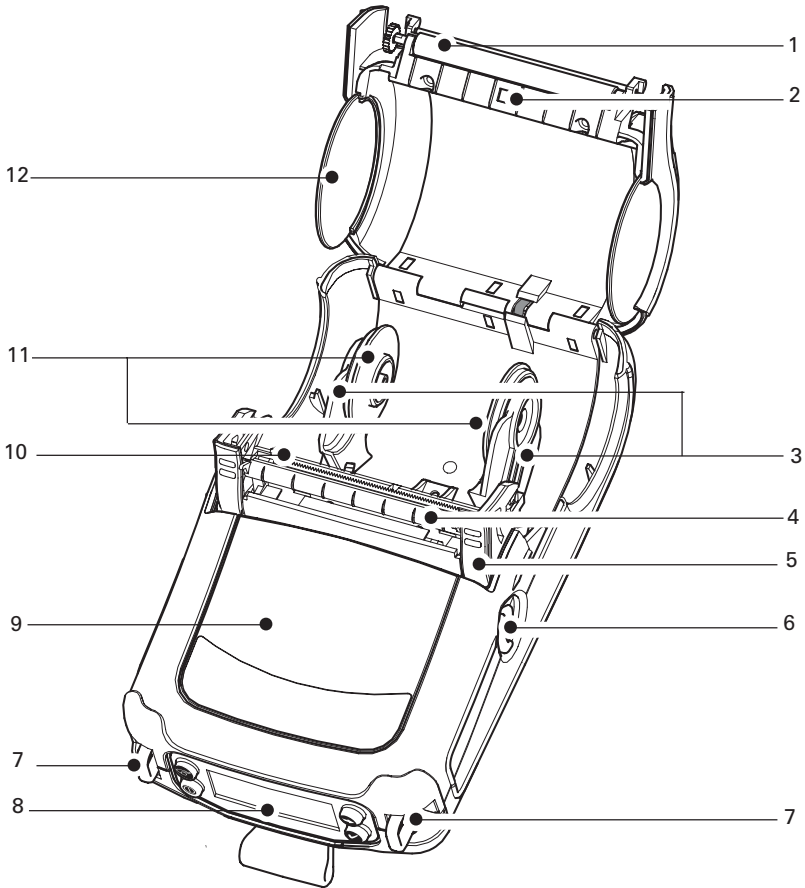

- 1 Platen Roller
- 2 Bar Sensor
- 3 Media Support
- 4 "EZ-Peel" Peeler
- 5 Latch
- 6 Latch Release Lever
- 7 "D" Rings
- 8 Control Panel
- 9 QuickLink™ Module
- 10 Print Head
- 11 Media Support Disks
- 12 Media Cover

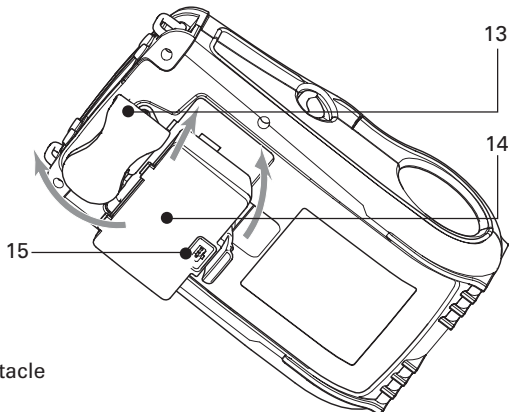

QL 420 Introduction

Figure 1C: QL 420 Overview

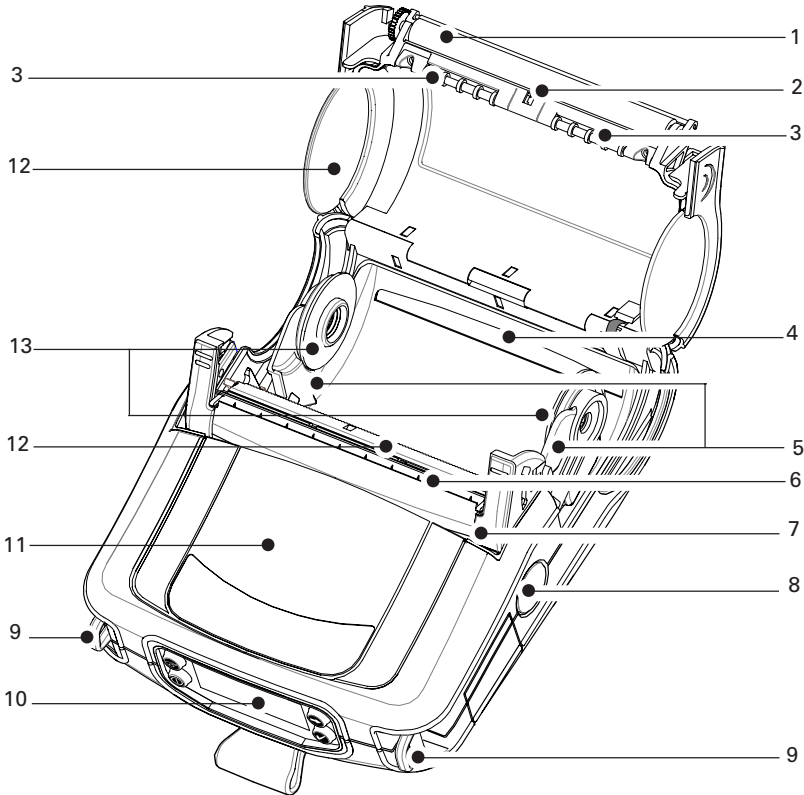

- 1 Platen Roller
- 2. Bar Sensor
- 3. Media Rollers
- 4. Rear Media Slot
- 5. Media Support
- 6. "EZ-Peel" Peeler
- 7. Latch
- 8. Latch Release Button
- 9. "D" Rings
- 10. Control Panel
- 11. QuickLink™ Module
- 12. Print Head
- 13. Media Support Disks
- 14. Media Cover
- 15. RS232 Communications Port
- 16. USB Port (QL Plus models only)
- 17. Belt Clip
- 18. Battery
- 19. Battery Charging Receptacle

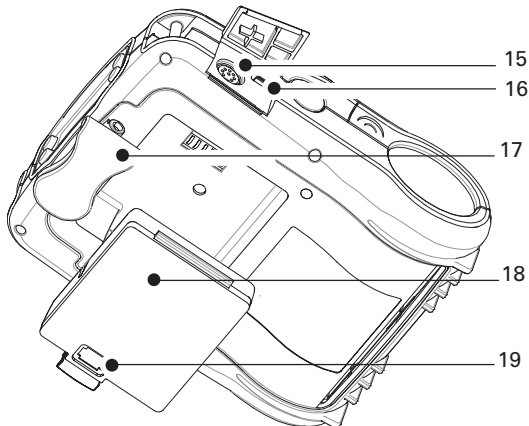

Getting Ready to Print

Battery

Installing the Battery



NOTE: Batteries are shipped uncharged. Remove protective shrink-wrap and labels from new battery packs prior to use.

1. Rotate the Belt Clip to allow access to the Battery compartment.
2. Insert the battery into the printer as shown in Figure 2,
3. Rock the Battery into the printer as shown until it locks in place.

When the battery is first installed, the Control Panel indicators may briefly turn on and then go off which indicates the battery is not fully charged (see "Charging the Battery" below and "Operator Controls").

You must charge the batteries fully before using them for the first time. To ensure maximum battery capacity, new batteries should go through two or three complete charge/discharge

Figure 2: Installing the Battery

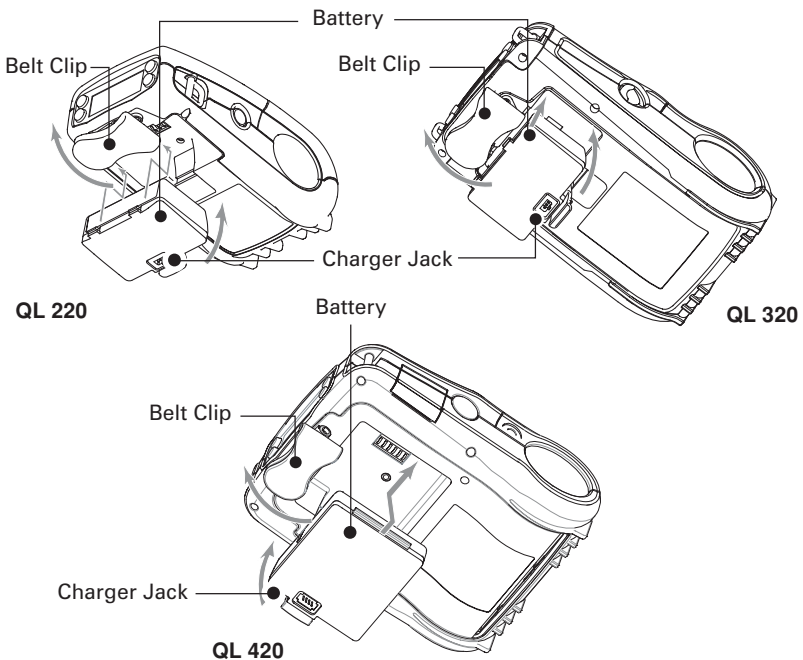

continued

Figure 3: Single Charger

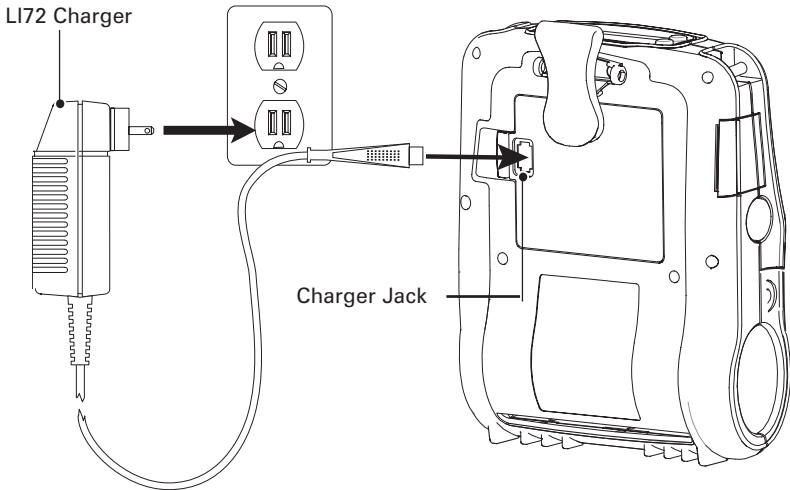

cycles when first put into service.

Charging the Battery

Model LI 72 Single Battery Charger

Refer to Figure 3. Your battery charger may look slightly different from the ones illustrated.

1. Install the battery in the printer and plug the Charger into the appropriate A.C. wall receptacle. Then insert the charge cable into the battery charger jack.
2. The charger LED will indicate the status of the charger as follows:
 - A steady light indicates the battery is undergoing a fast charge.
 - A slow blinking light indicates the charger is in trickle mode. The battery is ready for use.
 - A rapidly blinking light indicates a problem with the battery. The battery may have an internal short, or its charge monitoring circuitry may be malfunctioning. The battery should not be used any further.
 - Battery Packs may be charged either when installed in the printer or when removed.

⚠ Do not attempt to charge batteries with the Model LI 72 charger while printing. Attempting to print while charging can result in improperly charged batteries.

Model UCLI72-4 Quad Charger

The UCLI72-4 Quad Charger is designed to charge up to four QL Series battery packs simultaneously. Batteries must be removed from the printer to be charged in the Quad Charger.

1. Ensure that the charger has been installed properly per the Quad Charger instruction manual. Ensure that the power indicator on the front panel is on.

2. Remove any protective shrink-wrap and labels from all battery packs prior to use. Plug a battery pack into any one of the four charging bays as shown in Figure 4, noting the orientation of the battery pack. Slide the battery pack into the charging bay until it stops. Then rock the battery pack back until it snaps into place. The amber indicator directly under the battery being charged will turn on if the battery is properly inserted.

The indicators under the battery will allow you to monitor the charging process per the table below:

Amber	Green	Battery Status
On	Off	Charging
On	Flashing	80% charged (O.K. to use)
Off	On	Completely Charged
Flashing	Off	Fault

 *Note: A fault condition is caused by a problem with the battery. The charger may indicate a fault because the battery is too hot or cold to charge reliably. Try to charge the battery again when it returns to the room's ambient temperature. If the Amber indicator starts flashing on the second attempt, the battery should be discarded. Always dispose of batteries in a proper manner. Refer to Appendix D.*

Quad Charger Cycle Times :

Battery Status	QL 220/320	QL 420
Battery 80% Charged	1.25 Hrs.	2.5 Hrs.
Battery Fully Charged	2.5 Hrs.	5 Hrs.



NOTE: These times are for completely discharged batteries.

continued

Battery packs which are only partially discharged will take less time to reach their charged state. Batteries which have reached 80% of their charge capacity may be used, however, it is recommended that you allow the batteries to reach a full charge to maintain maximum battery life.

The UCLI72-4 Quad Charger has a safety feature which stops charging a battery after six hours regardless of its charge state.

Figure 4: Quad Charger

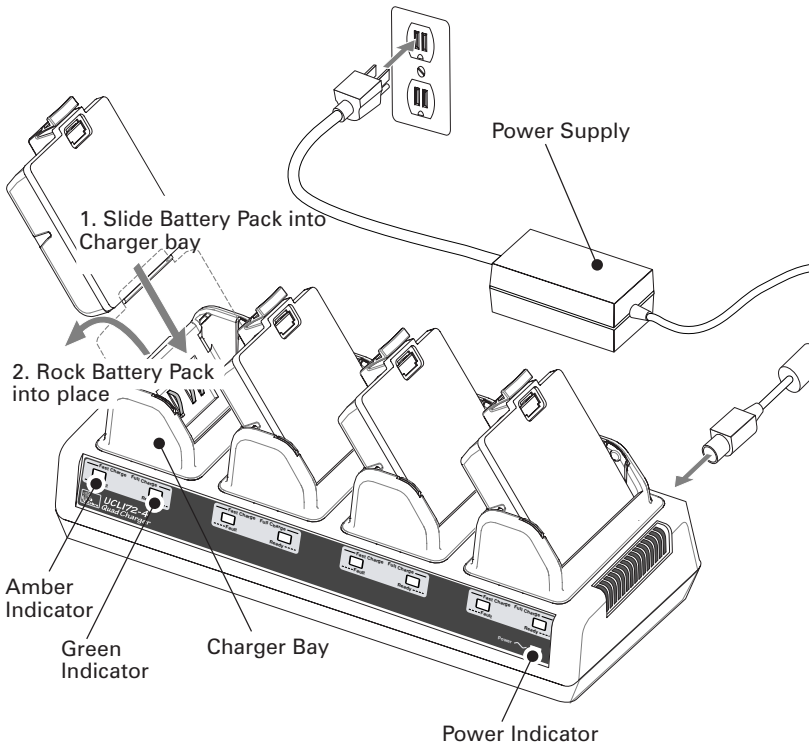

Battery Safety

⚠️ Avoid accidental short circuiting of any battery. Allowing battery terminals to contact conductive material will create a short circuit which could cause burns and other injuries or could start a fire. Always dispose of used batteries properly. Refer to Appendix D for more battery recycling information.

Use of any charger not approved specifically by Zebra for use with its batteries could cause damage to the battery pack or the printer and will void the warranty.

Charger Safety



Use care in locating either the single Charger or the Quad Charger. Do not block the ventilating slots on the top and bottom covers. Ensure that the Charger is plugged into a power source which won't accidentally be turned off if you will be charging batteries overnight.

Do not place the Quad Charger in locations where liquids or metallic objects may be dropped into the charging bays.

Loading the Media

You can operate QL Series printers in one of two different modes: Tear-Off or Peel-Off. Tear-Off mode allows you to tear off each label (or a strip of labels) after it is printed. In Peel-Off mode, the backing material is peeled away from the label as it is printed. After you remove this label, the next one is printed.

Installing the Media

QL 420 and QL 220 Printers

1. Open the printer: Refer to Figure 5 (QL 420 shown).
 - Press the latch release button on the side of the printer as shown at "1" below. The latch assembly will flip open automatically
 - On the QL 420, pull up the latch assembly completely as shown at "2" to unlatch the Media Cover.
 - Rotate the Media Cover back as shown at "3", exposing the media compartment and the adjustable media supports.

Figure 5: Opening the QL 420 & QL 220

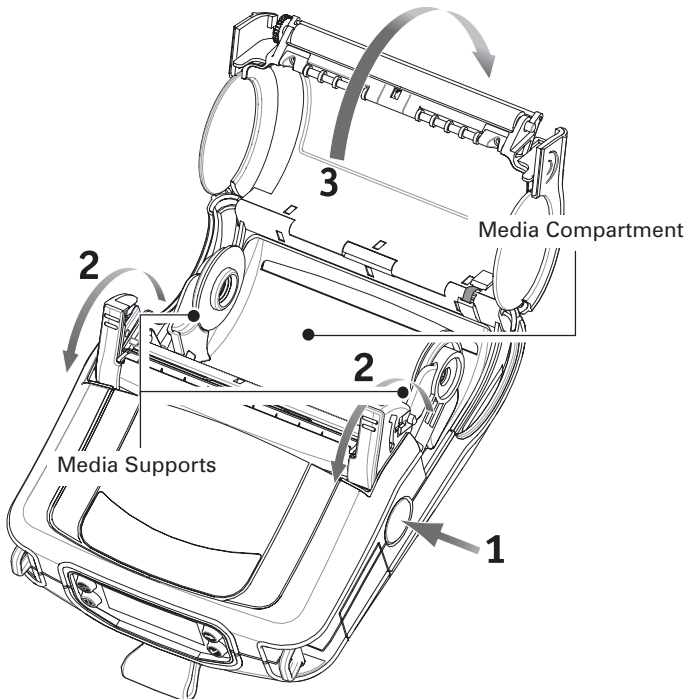

QL 320 Printers

1A. Open the printer: Refer to Figure 5a.

- Rotate the latch release levers on each side of the printer as shown at "1" below. The latch assembly will flip open automatically as shown at "2".
- Rotate the Media Cover back as shown at "3", exposing the media compartment and the adjustable media supports.

Figure 5A: Opening the QL 320

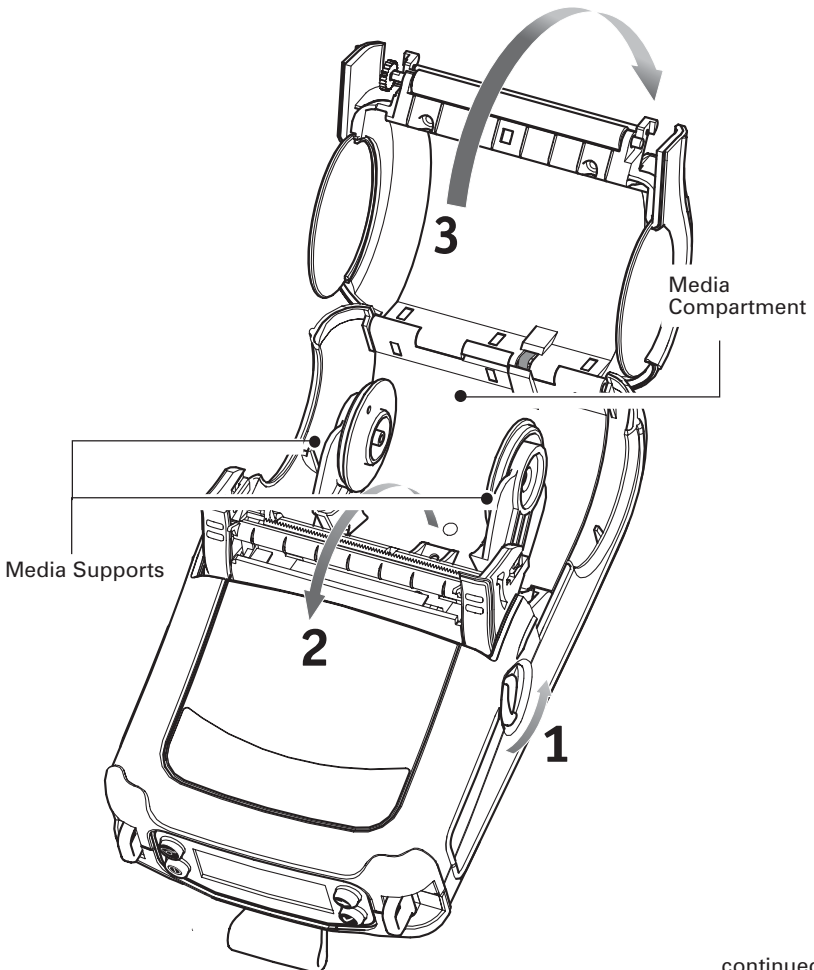

All models

2. Load the media:

Loading media from an internal supply. Refer to Figure 6.

- Pull the media supports apart, insert the roll of media between them, and let the media supports close. Ensure that the media pulls off the core in the direction shown in Figure 6. The supports will adjust themselves to the width of the media, and the media should be able to spin freely on the supports.

Figure 6: Installing Media

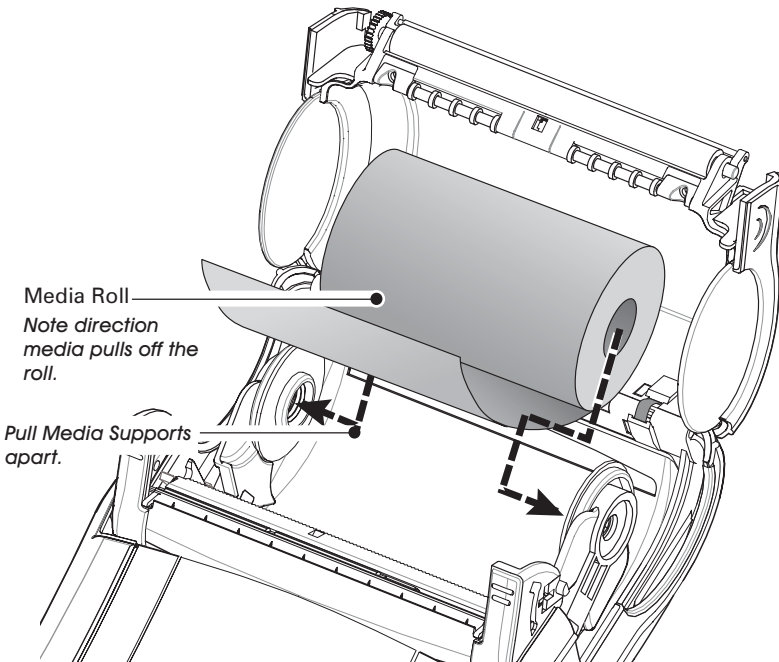

QL 420 Only

2A. Load the media (continued):

Loading media from an external supply. Refer to Figure 7.

The QL 420 has a loading slot in the rear of the media compartment which allows you to use standard 4" (101.6 mm) wide fan-fold media from an external supply. The external supply must be designed such that it does not exert excessive drag as media is fed through the printer, which could result in distorted printing.

Zebra can provide a vehicle mount (p/n DC16620-1) designed specifically for the QL 420 which incorporates an external media supply bin.

- Pull the media supports apart, insert a Media Spacer (Zebra part number BA16625-1) between them, and let the media supports close.

Insert the media from the external supply through the rear feed slot, between the media guides and up through the media compartment as shown.

Make sure the side of the media you will be printing on faces the print head.

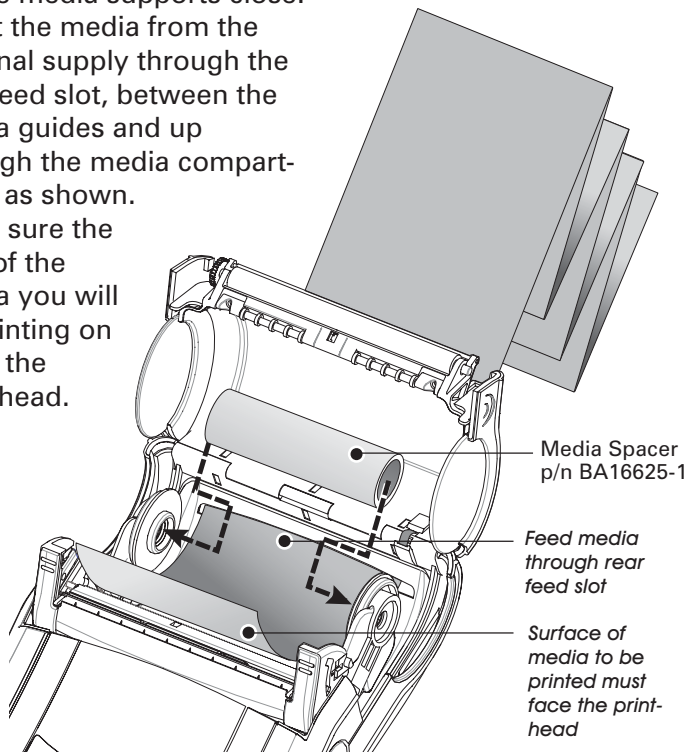

Figure 7: Installing Media from an External Supply (QL 420 only)

3. Close the Media Cover: Refer to Figure 8.

- If you plan to use the printer in the tear-off mode, close the media cover as shown at "2", then rotate the latch assembly as shown until it locks into place, as shown at "4".
- If you plan to use the printer in the peel-off mode, peel a few labels off of the media and pull it out of the printer as shown at "1". Close the media cover as shown at "2". Rotate the "EZ-Peel" peeler bar until it locks into place on the latch, as shown at "3", then rotate the Latch as shown until it locks into place, as shown at "4".
- Turn on the printer or press the Feed button if the printer is already on.

The printer will advance the media to the next label, if printing labels. If you are printing on journal media, the printer will advance a short strip of media and will then be ready for printing.

Figure 8: Closing the Media Cover

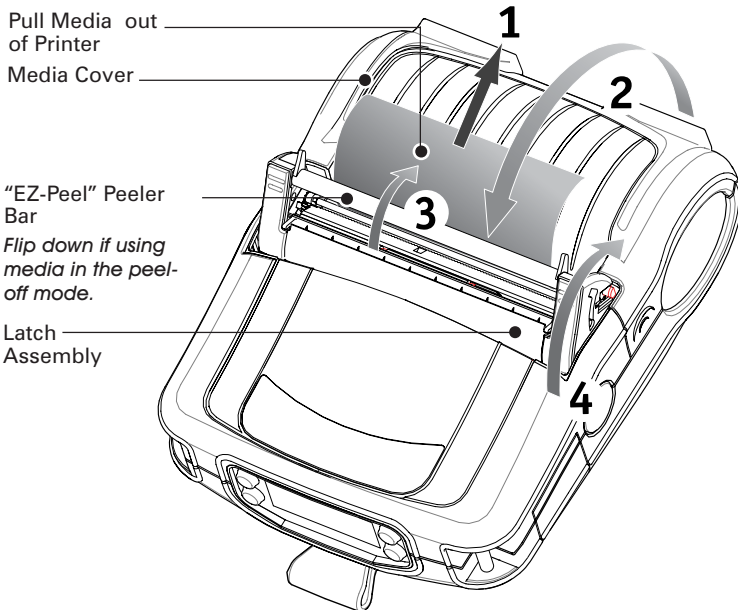

Operator Controls

QL Series printers are available with one of two possible control panels. The standard control panel is detailed below and in Figure 9. The optional control panel (Figure 10) features an LCD which allows easy display and selection of many printer functions detailed on following pages.

Standard Keypad

The standard keypad has three control buttons and two multipurpose indicators.

- The Power button turns the printer on and off.
- The Feed button advances a length of media which is determined by the type of media being used. Label media will be advanced to the next gap or bar sense marker. Journal (plain) media will be advanced a length determined by the printer's software.
- The Function button is controlled by a printer's specific application to support such functions as:
 - Print a battery level report.
 - Print the Local Area Network (LAN) status
 - Print a Short Range Radio Frequency (SRRF) status
 - Print a media supply report

The green LED on the left side of the control panel indicates the status of several printer features:

- A slowly blinking sequence indicates the printer's battery needs charging.
- Printers with a wireless QuickLink module installed: a quickly blinking sequence indicates the printer has not established a link to either a Local Area Network or a compatible wireless equipped terminal.
- Printers with a wireless QuickLink module installed: A steadily lit indicator shows that the printer has established a wireless link, either to the LAN or to a compatible terminal.
A steadily lit green indicator on a non-wireless printer is a power-on indicator.

The yellow LED on the right side of the control panel has two indication conditions.

- A rapidly blinking yellow LED and a chime indicate that no application has been loaded into the printer.

continued

- Printers with a wireless QuickLink module installed: a rapidly blinking LED indicates normal data transmission.
- A steadily lit yellow LED indicates an error condition. This can be caused by one of the following:
 1. The media cover is not completely closed and latched.
 2. The printer is out of media.

Figure 9: Standard Control Panel

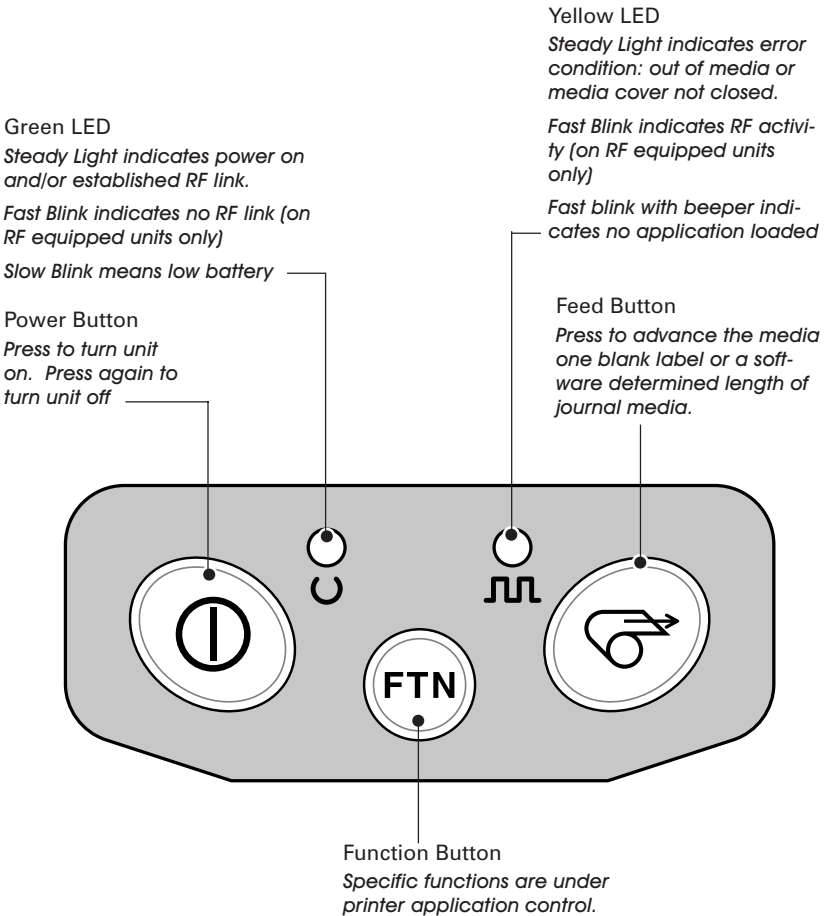







LCD Control Panel

The optional LCD control panel has buttons for the power on/off and media feed functions just as in the standard control panel. In addition, it has two keys which allow easy navigation and selection of menu options affecting many printer functions.

The “Scroll” button allows scrolling through the various options and settings. The “Select” button allows selection of the option or function displayed on the screen.

The top of the screen has a row of status icons which indicate the state of various printer functions:

-  Indicates that the printer is receiving or transmitting data via a Bluetooth connection. A flashing icon indicates data transmission.
This icon is functional only on printers with the Bluetooth wireless option installed. Printers with earlier firmware versions may not use this icon and will display the ▼ icon instead.
-  Indicates that the printer is connected to a radio network via the 802.11 protocol. It remains on steadily with an 802.11 connection.
If the icon is off, there is no connection to a radio network.
-  A flashing icon indicates low battery status. You should suspend any printing operations and recharge or replace the Battery Pack as soon as is convenient.
-  A flashing icon indicates that the media cover is open or not properly latched.
-  A flashing icon indicates that a file is being downloaded to the printer.
-  A flashing icon indicates that the printer does not detect any media. This could indicate an out of media condition, or improperly loaded media.

In addition to the status icons, the LCD control panel can display many of the printer’s settings and functions as text. Applications can be written to allow the user to view and /or modify these settings using the scroll and select keys on the

continued

display. Refer to the “LCD Functions Table” on the following page for the full set of printer features that can be made available with the LCD panel.

The LCD has a backlighting option which allows viewing of the screen in a dark environment, or provides better contrast in a very bright environment. Use of the display backlight will decrease the time the printer will run between charges. Refer to the section “Extending Battery Life” for more information.

Figure 10: Optional LCD Control Panel

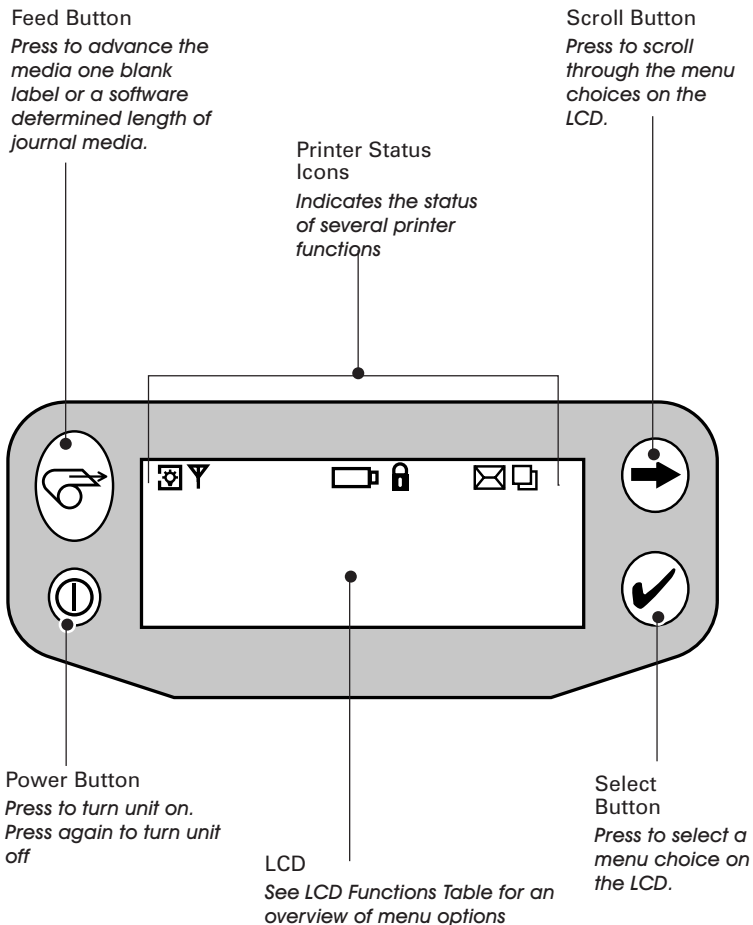

Extended LCD Functions

Function	Default setting	Scroll & Select Options
Sensor Type	Bar	<ul style="list-style-type: none"> • Bar • Gap
Baud Rate	19200	<ul style="list-style-type: none"> • 9600 • 19200 • 32400
Data Bits	8	<ul style="list-style-type: none"> • 7 • 8
WLAN ID*	Factory Set Value	N/A
Label Top	000	<ul style="list-style-type: none"> • Increase (+120 dots max.) • Decrease (-120 dots max.)
Left Position	000	<ul style="list-style-type: none"> • Increase (+120 dots max.) • Decrease (-120 dots max.)
LCD Contrast	0	<ul style="list-style-type: none"> • Increase • Decrease
No-activity Timeout*	60 sec.	<ul style="list-style-type: none"> • 60 sec. • 5 min. • 10 min. • 30 min • Custom
Tear-off Position	00	<ul style="list-style-type: none"> • Increase (+120 dots max.) • Decrease (-120 dots max.)
Media Type	Label	<ul style="list-style-type: none"> • Label • Journal
Media Width Sensing†	Off	<ul style="list-style-type: none"> • On • Off • Display Width
LCD Backlight	Off	<ul style="list-style-type: none"> • On • Off • Momentary On w/ time delay
Factory Reset (Resets all to factory set values)	No	<ul style="list-style-type: none"> • No • Yes

* Some parameters, such as the WLAN ID number and non-standard no-activity time out values can be set using a PC running Zebra's Label Vista label creation program and a data cable link to the printer.

† Media width sensing is an option. Display for this option may not be visible, or selection options may change, depending on the printer's application.

Verify the Printer Is Working

Before you connect the printer to your computer or portable data terminal, make sure that the printer is in proper working order. You can do this by printing a configuration label using the “two key reset” method. If you can’t get this label to print, refer to “Troubleshooting”.

Printing a Configuration Label

1. Turn the printer off. Load the media compartment with journal media (media with no black bars printed on the back)
2. Press and hold the Feed Button.
3. Press and release the Power button and keep the Feed button pressed. When printing starts, release the Feed button.

The unit will print a line of interlocking “x” characters to ensure all elements of the print head are working, print out the version of software loaded in the printer and then print two reports.

The first report indicates model, ROM version, serial number, baud rate, etc. The second report prints out more detailed information on the printer’s configuration and parameter settings. If no second report appears, there is no application loaded. (See the Troubleshooting Section for sample printouts and a further discussion on how to use the configuration label as a diagnostic tool.)

Connecting the Printer

The printer must establish communications with a host terminal which sends the data to be printed. Communications occur in four basic ways:

- By a cable between the printer and its host terminal. All QL Series printers communicate by the RS232C protocol. QL Plus Series printers can communicate by either RS232C or USB 2.0 protocols. (USB drivers are included in the Zebra Universal Driver which can be downloaded from www.zebra.com/drivers).
- Linking to a host terminal via Infrared (usually by means of the industry standard IrDA protocol)
- By means of a Bluetooth™ short range radio frequency link.

- By means of a wireless LAN (Local Area Network) per 802.11b specifications.

Cable Communications

⚠ CAUTION. The printer should be turned off before connecting or disconnecting the communications cable.

All QL Series printers can communicate by cable; the specific cable supplied with your printer will vary with the host terminal and your model printer.

RS232C Communications

The 8-pin circular connector on your communications cable plugs into the serial communications port on the side of the printer. QL Plus model printers also have a USB port.

USB Communications (QL Plus units only)

The small connector on the USB cable plugs into the printer. The connectors are keyed to assure correct alignment; do not

Figure 11: Cable Communications

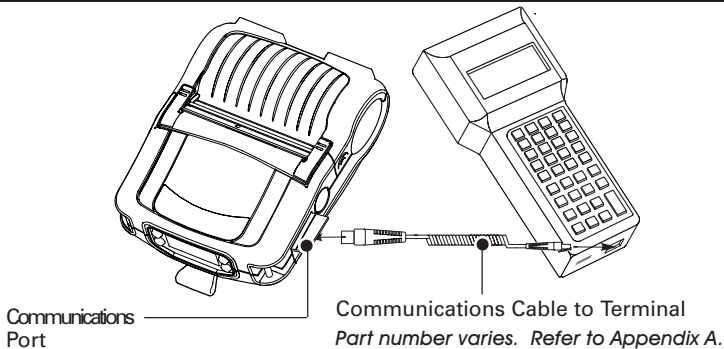
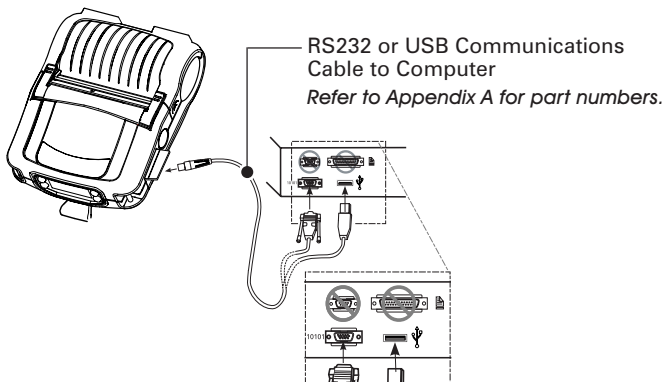

Figure 12: Communications with a P.C.



try to force the cable if it does not plug in. The other end of the cable must be plugged into the host terminal as shown in Figure 11, or to a serial or USB port on a computer (Figure 12.) The QL Plus series is configured with the USB Open HCI interface driver allowing it to communicate with Windows® based devices.

USB drivers are included in the Zebra Universal Driver which can be downloaded from: www.zebra.com/drivers. Other terminals or communications devices may require the installation of special drivers to use the USB connection. Consult the factory for further details.

Providing Strain Relief for Communications Cable

If you will be connecting a communications cable to the printer permanently, use the strain relief features built into the belt clip retainer to prevent excessive strain on the communications connector. There are two kinds of strain relief features. If you are using the printer with the standard belt clip, bend the cable in a broad loop to relieve stress on the connector and press it into the retaining feature on the belt clip retainer as shown in figure 13.

Figure 13: Communications Strain Relief

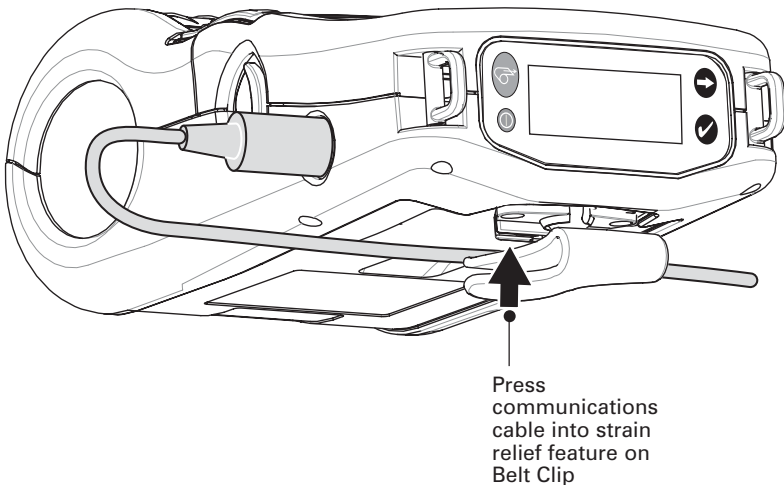

If you have a printer equipped with the Kickstand option, you must first remove the belt clip retainer as shown in Figure 14, retaining the two screws holding the retainer to the lower cover. Arrange the communications cable in a broad loop as detailed above, and capture it in the strain relief feature on the bottom of the belt clip retainer. Then re-secure the belt clip retainer to the bottom cover of the printer.

Figure 14: Communications Strain Relief with Kickstand option



Kickstand is not shown in this view for clarity

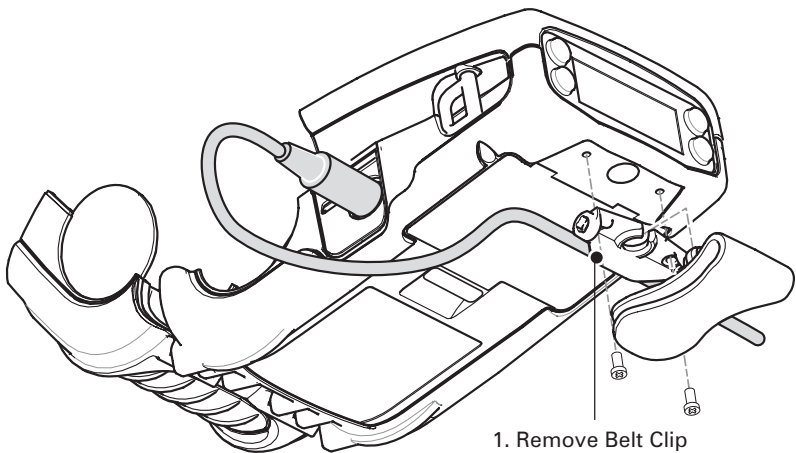

1. Remove Belt Clip Retainer, along with Belt Clip and Kickstand.
2. Press communications cable into strain relief feature on bottom of Belt Clip
3. Reassemble Belt Clip to bottom cover.

IR Communications

Printers equipped for infrared (IR) communications are identified by a small "IR" logo on the unit's label. (IR functions are disabled if a communications cable is used.) Printers with the IR option conform to the IrDA communications protocol.

Ensure that there is a direct line of sight between the printer and the terminal that will be sending data. The IR window on the front of the printer must face the corresponding window on the terminal to properly send and receive signals.

IrDA compliant terminals will automatically initiate communications to the printer. An IrDA terminal will seek out any linkable devices and establish communications between them, even turning the printer on if necessary.

Figure 14: IR Communications

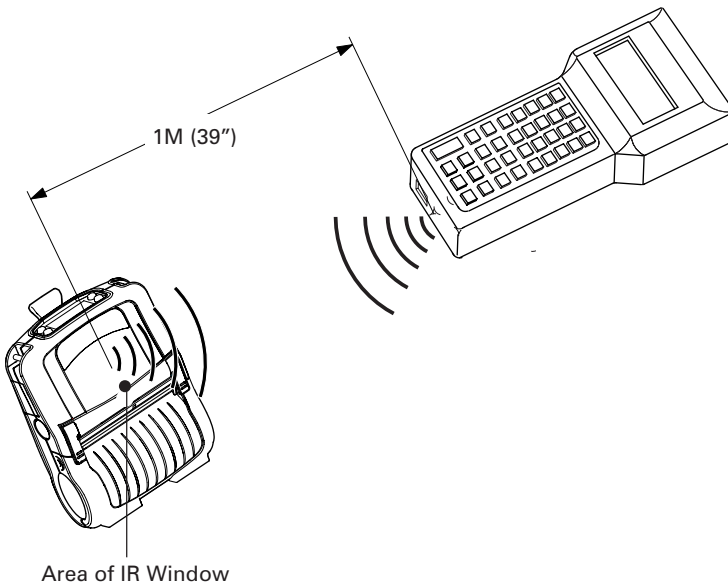

Wireless Communications with Bluetooth™ using ZBR3 Radio

The following section only applies when the ZBR3 Bluetooth Module (FCC ID: I28MD-BTC2TY2) is installed in a QL Series printer (note that only one of the radio options can be installed in the printer at one time). The antenna used for this transmitter must not be co-located or must not operate in conjunction with any other antenna.

“Bluetooth” is a worldwide standard for the exchange of data between two devices via radio frequencies. Bluetooth radios are relatively low powered to help prevent interference with other devices running at similar radio frequencies. This limits the range of a Bluetooth device to about 10 meters (about 32 feet).

Both the printer and the device it communicates with must follow the Bluetooth standard.



Exposure to Radio Frequency Radiation

The radiated output power of this internal Bluetooth radio is far below the FCC radio frequency exposure limits. Nevertheless, this Bluetooth radio must be used in such a manner that the antenna is 2.5 cm or further from the human body.

The radio and antenna are mounted internally in this printer such that when the printer is worn with the back of the printer against the body and the front of the printer (where paper exits) away from the body, then the 2.5 cm distance between the antenna and the users body will be met. Do not use the printer in an unauthorized manner.

The internal Bluetooth radio operates within guidelines found in radio frequency safety standards and recommendations. The level of energy emitted is far less than the electromagnetic energy emitted by other wireless devices such as mobile phones.

CE 0336

Important Notice:

This device is a portable RF printer intended for commercial and industrial use in all EU and EFTA member states.

European Regulatory Information for this Radio

This device is intended for use in all EU and EFTA member states.

Europe – EU Declaration of Conformity

This device complies with the essential requirements of the R&TTE Directive 1999/5/EC. The following test methods have been applied in order to prove presumption of compliance with the R&TTE Directive 1999/5/EC:

- EN 60950: 2000
Safety of Information Technology Equipment
- EN 300 328-2 V1.4.1 (2003-04)
Technical requirements for spread-spectrum radio equipment
- EN 301 489-1/-17 V1.5.1/1.2.1 (2003-12) -17 v1.2.1 (2002-08)
EMC requirements for spread-spectrum radio equipment.

This device is a 2.4 GHz wireless LAN transceiver, intended for indoor home and office use in all EU and EFTA member states.

Bluetooth™ Networking Overview

In order to exchange data, two Bluetooth enabled devices must establish a connection. Bluetooth software is always running in the background, ready to respond to connection requests. One device (known as the *master* or the *client*) must request a connection with another. The second device (the *slave* or the *server*) then accepts or rejects the connection. A Bluetooth enabled QL Series printer will normally act as a slave, but in theory any Bluetooth device can be either a master or a slave. This miniature network is sometimes referred to as a "piconet" and can consist of several Bluetooth enabled devices.

For the most part, communications using the Bluetooth protocol are initiated and processed without any operator intervention, much like the IrDA system described previously.

Each Bluetooth enabled QL Series printer is identified by a unique Bluetooth Device Address (BDA) loaded into its Quick-Link module when manufactured.

Wireless Local Area Network (WLAN) Module Using CF Radio

The following section only applies when the CF (Compact Flash) WLAN module (With FCC ID: I28MD-RW4137) is installed in a QL Series printer (note that only one of the radio options can be installed in the printer at one time). The antenna used for this transmitter must not be co-located or must not operate in conjunction with any other antenna.

QL model printers have the FCC ID number label on the front of the module, and QL Plus models have the FCC ID number on a label on the back of the unit.

 **WARNING:** Use of a QL Series printer with the radio module marked with FCC ID: I28MD-RW4137" meets the FCC requirements for radio frequency (RF) radiation exposure in the standard body worn configuration with no minimum separation. In this configuration, which applies whether the belt clip or shoulder strap is used, the face of the printer from which paper is transported is facing away from the user's body. The standard configuration must always be used when the printer is body worn. QL 220/220 Plus, QL 320/320 Plus and QL 420/420 Plus printers with this radio option have been SAR tested. The maximum SAR value measured for each model is listed below:



Model	SAR value W/Kg (1g average)
QL220/220 plus	0.0618
QL 320/320 plus	0.0500
QL 420/420 plus	0.0432

European Regulatory Information for this Radio

AT	BE	CY	CZ	DK
EE	FI	FR	DE	GR
HU	IE	IT	LV	LT
LU	MT	NL	PL	PT
SK	SI	ES	SE	GB

Note: -Member states in the EU with restrictive use for this device are crossed out!

This device is also authorized for use in all EFTA member states (CH, IS, LI, NO)

 0336 	<p>Important Notice: This device is a portable RF printer intended for commercial and industrial use in all EU and EFTA member states except in France where restrictive use applies.</p>
---	--

continued

Europe – EU Declaration of Conformity

This device complies with the essential requirements of the R&TTE Directive 1999/5/EC. The following test methods have been applied in order to prove presumption of compliance with the R&TTE Directive 1999/5/EC:

- EN 60950: 2000
- Safety of Information Technology Equipment
- EN 300 328-2 V1.6.1 (2004-11)
- Technical requirements for spread-spectrum radio equipment
- EN 301 489-1/-17 V1.5.1/1.2.1 (2003-12) -17 v1.2.1 (2002-08)
- EMC requirements for spread-spectrum radio equipment.

This device is a 2.4 GHz wireless LAN transceiver, intended for indoor home and office use in all EU and EFTA member states, except in France where restrictive use applies.

The use of this frequency band in France is subject to restrictions. You may only use channels 10 and 11 (2457 and 2462 MHz) on French territory, except in those French departments as listed in the table below where channels 1-13 (2412-2472 MHz) may be used. For more information see <http://www.anfr.fr/> and/or <http://www.art-telecom.fr>

01	Ain	36	Indre	69	Rhone
02	Aisne	37	Indre et Loire	70	Haute Saone
03	Allier	39	Jura	71	Saone et Loire
05	Hautes Alpes	41	Loir et Cher	72	Sarthe
08	Ardennes	42	Loire	75	Paris
09	Ariege	45	Loiret	77	Seine et Marne
10	Aube	50	Manche	78	Yvelines
11	Aude	54	Meurthe et Moselle	79	Deux Sievres
12	Aveyron	55	Meuse	82	Tarn et Garonne
16	Charente	57	Moselle	84	Vaucluse
19	Correze	58	Nievre	86	Vienne
2A	Corse Sud	59	Nord	88	Vosges
2B	Haute Corse	60	Oise	89	Yonne
21	Cote d'Or	61	Orne	90	Territoire de Belfort
24	Dordogne	63	Puy de Dome	91	Essonne
25	Doubs	64	Pyrenees Atlantique	92	Hauts de Seine
26	Drome	65	Hautes Pyrenees	93	Seine St Denis
27	Eure	66	Pyrenees Orientales	94	Val de Marne
32	Gers	67	Bas Rhin		
35	Ille et Vilaine	68	Haute Rhin		

QL 320/320 Plus Wireless Local Area Network (WLAN) Module Using PCMCIA Radio

The following section only applies when the PCMCIA WLAN module (FCC ID: I28-QL320352) is installed in the QL 320 or QL 320 Plus printer (note that only one of the radio options can be installed in the printer at one time). The antenna used for this transmitter must not be co-located or must not operate in conjunction with any other antenna.

The FCC ID number label is on the front of the module for QL 320 and on the back label of QL 320 Plus. On all models the text can be read with the module installed.



 **WARNING:** Use of the QL 320/320 Plus with the radio module marked with FCC ID: I28-QL320352 meets the FCC requirements for radio frequency (RF) radiation exposure in the standard body worn configuration with no minimum separation. In this configuration, which applies whether the belt clip or shoulder strap is used, the face of the printer from which paper is transported is facing away from the user's body. The standard configuration must always be used when the printer is body worn. This configuration maintains the required 1 cm separation distance.

The printer with this radio option has been SAR tested. The maximum SAR value measured was .819 W/kg averaged over 1 gram.

European Regulatory Information for this Radio

AT	BE	CY	CZ	DK
EE	FI	FR	DE	GR
HU	IE	IT	LV	LT
LU	MT	NL	PL	PT
SK	SI	ES	SE	GB

Note: -Member states in the EU with restrictive use for this device are crossed out!

 0336 	Important Notice: This device is a portable RF printer intended for commercial and industrial use in all EU and EFTA member states except in France where restrictive use applies.
---	--

This device is also authorized for use in all EFTA member states (**CH, IS, LI, NO**)

Europe – EU Declaration of Conformity

This device complies with the essential requirements of the R&TTE Directive 1999/5/EC. The following test methods have been applied in order to prove presumption of compliance with the R&TTE Directive 1999/5/EC:

- EN 60950: 2000

Safety of Information Technology Equipment

- EN 300 328-2 V1.2.1 (2001-12)

Technical requirements for spread-spectrum radio equipment

- EN 301 489-17 V1.2.1 (2002-08)

EMC requirements for spread-spectrum radio equipment.

This device is a 2.4 GHz wireless LAN transceiver, intended for indoor home and office use in all EU and EFTA member states, except in France where restrictive use applies.

The use of this frequency band in France is subject to restrictions. You may only use channels 10 and 11 (2457 and 2462 MHz) on French territory, except in those French departments as listed in the table below where channels 1-13 (2412-2472 MHz) may be used. For more information see <http://www.anfr.fr/> and/or <http://www.art-telecom.fr>

01	Ain	36	Indre	69	Rhone
02	Aisne	37	Indre et Loire	70	Haute Saone
03	Allier	39	Jura	71	Saone et Loire
05	Hautes Alpes	41	Loir et Cher	72	Sarthe
08	Ardennes	42	Loire	75	Paris
09	Ariege	45	Loiret	77	Seine et Marne
10	Aube	50	Manche	78	Yvelines
11	Aude	54	Meurthe et Moselle	79	Deux Sievres
12	Aveyron	55	Meuse	82	Tarn et Garonne
16	Charente	57	Moselle	84	Vaucluse
19	Correze	58	Nievre	86	Vienne
2A	Corse Sud	59	Nord	88	Vosges
2B	Haute Corse	60	Oise	89	Yonne
21	Cote d'Or	61	Orne	90	Territoire de Belfort
24	Dordogne	63	Puy de Dome	91	Essonne
25	Doubs	64	Pyrenees Atlantique	92	Hauts de Seine
26	Drome	65	Hautes Pyrenees	93	Seine St Denis
27	Eure	66	Pyrenees Orientales	94	Val de Marne
32	Gers	67	Bas Rhin		
35	Ille et Vilaine	68	Haute Rhin		

QL 420/420 Plus Wireless Local Area Network (WLAN) Module Using PCMCIA Radio

The following section only applies when the PCMCIA WLAN module (FCC ID: I28-QL420352) is installed in the QL 420 or QL 420 Plus printer. (Note that only one of the radio options can be installed in the printer at one time). The antenna used for this transmitter must not be co-located or must not operate in conjunction with any other antenna.

The FCC ID number label is on the front of the module for the QL 420 and on the back label of the QL 420 Plus. On all models the text can be read with the module installed.



WARNING: Use of the QL 420 or QL 420 Plus with the radio module marked with "FCC ID: I28-QL420352" meets the FCC requirements for radio frequency (RF) radiation exposure in the standard body worn configuration with no minimum separation. In this configuration, which applies whether the belt clip or shoulder strap is used, the face of the printer from which paper is transported is facing away from the user's body. The standard configuration must always be used when the printer is body worn. This configuration maintains the required 1 cm separation distance.

The printer with this radio option has been SAR tested. The maximum SAR value measured was 1.04. W/kg averaged over 1 gram.

European Regulatory Information for this Radio

AT	BE	CY	CZ	DK
EE	FI	FR	DE	GR
HU	IE	IT	LV	LT
LU	MT	NL	PL	PT
SK	SI	ES	SE	GB

Note: -Member states in the EU with restrictive use for this device are crossed out!

This device is also authorized for use in all EFTA member states (CH, ICE, LI, NOR)

CE 0336

Important Notice:

This device is a portable RF printer intended for commercial and industrial use in all EU and EFTA member states except in France where restrictive use applies.

Europe – EU Declaration of Conformity

This device complies with the essential requirements of the R&TTE Directive 1999/5/EC. The following test methods have been applied in order to prove presumption of compliance with the R&TTE Directive 1999/5/EC:

- EN 60950: 2000

Safety of Information Technology Equipment

- EN 300 328-2 V1.2.1 (2001-12)

Technical requirements for spread-spectrum radio equipment

- EN 301 489-17 V1.2.1 (2002-08)

EMC requirements for spread-spectrum radio equipment.

This device is a 2.4 GHz wireless LAN transceiver, intended for indoor home and office use in all EU and EFTA member states, except in France where restrictive use applies.

The use of this frequency band in France is subject to restrictions. You may only use channels 10 and 11 (2457 and 2462 MHz) on French territory, except in those French departments as listed in the table below where channels 1-13 (2412-2472 MHz) may be used. For more information see <http://www.anfr.fr/> and/or <http://www.art-telecom.fr>

01	Ain	36	Indre	69	Rhone
02	Aisne	37	Indre et Loire	70	Haute Saone
03	Allier	39	Jura	71	Saone et Loire
05	Hautes Alpes	41	Loir et Cher	72	Sarthe
08	Ardennes	42	Loire	75	Paris
09	Ariege	45	Loiret	77	Seine et Marne
10	Aube	50	Manche	78	Yvelines
11	Aude	54	Meurthe et Moselle	79	Deux Sievres
12	Aveyron	55	Meuse	82	Tarn et Garonne
16	Charente	57	Moselle	84	Vaucluse
19	Correze	58	Nievre	86	Vienne
2A	Corse Sud	59	Nord	88	Vosges
2B	Haute Corse	60	Oise	89	Yonne
21	Cote d'Or	61	Orne	90	Territoire de Belfort
24	Dordogne	63	Puy de Dome	91	Essonne
25	Doubs	64	Pyrenees Atlantique	92	Hauts de Seine
26	Drome	65	Hautes Pyrenees	93	Seine St Denis
27	Eure	66	Pyrenees Orientales	94	Val de Marne
32	Gers	67	Bas Rhin		
35	Ille et Vilaine	68	Haute Rhin		

Frequency Hopping Wireless Local Area Network (WLAN) Module Using PCMCIA Radio (QL 320 and QL 420 only)



NOTE: This option will not be offered after October, 2005

The following section only applies when the PCMCIA FH WLAN module (FCC ID: I28MD-QL3201) is installed in a QL 320 or QL 420 printer (note that only one of the radio options can be installed in a printer at one time). The antenna used for this transmitter must not be co-located or must not operate in conjunction with any other antenna.

The FCC ID number label is on the front of the radio module. The regulatory text can be read with the module installed.



WARNING: Use of the QL 320 or QL 420 with the radio module marked with FCC ID: I28MD-QL3201 meets the FCC requirements for radio frequency (RF) radiation exposure in the standard body worn configuration with no minimum separation. In this configuration, which applies whether the belt clip or shoulder strap is used, the face of the printer from which paper is transported is facing away from the user's body. The standard configuration must always be used when the printer is body worn. This configuration maintains the required 1 cm separation distance.

The QL 320 and QL 420 with this radio option have been SAR tested. The maximum SAR value measured for the QL 320 was .604 W/kg averaged over 1 gram. The maximum SAR value measured for the QL 420 was .899 W/kg averaged over 1 gram.

European Regulatory Information for this Radio

AT	BE	CY	CZ	DK
EE	FI	FR	DE	GR
HU	IE	IT	LV	LT
LU	MT	NL	PL	PT
SK	SI	ES	SE	GB

Note: -Member states in the EU with restrictive use for this device are crossed out! This device can only be used indoors in France.

This device is also authorized for use in all EFTA member states (CH, IS, LI,NO)

CE 0336

Important Notice:

This device is a portable RF printer intended for commercial and industrial use in all EU and EFTA member states except in France where restrictive use applies.

Europe EU Declaration of Conformity

This device complies with the essential requirements of the R&TTE Directive 1999/5/EC. The following test methods have been applied in order to prove presumption of compliance with the R&TTE Directive 1999/5/EC:

- EN 300 328-2 V1.3.1 (2001-12)- Technical requirements for spread-spectrum radio equipment
- EN 301 489-17 V1.2.1 (2002-08)- EMC requirements for spread-spectrum radio equipment

In France there are restrictions in the use of this device. A restricted frequency band exists in France. When operating this device on French territory you may only use channels 10 and 11 (2457 and 2463 MHz). It is not allowed to operate this device at any other frequency supported by the device. For more information see <http://www.anfr.fr/>

WLAN Overview

All QL Series printers can be equipped with a radio in the standard PCMCIA footprint using the industry standard 802.11 or 802.11b protocol. QL Series printers will have the FCC I.D. number of the radio on the product label. QL Plus Series printers will have the FCC ID number on the serial number label on the back of the unit.

These printers allow wireless communication as a node within a local area network, (LAN) and its wireless capabilities allow communications from any point within the LAN's perimeter. Methods of establishing communications to the printer will vary with each LAN application.

QL 220 and QL 220 Plus Wireless Network Printers with the CF module can be identified by the text "Wireless Network Printer" and FCC ID: *128MD-QL4137* either on the front of the unit (QL 220) or on the label on the back of the unit (QL 220 Plus).

QL 320 and QL 420 printers with the PCMCIA module can be identified by the text "Wireless Network Printer" and FCC ID number *128-QL420352* either on the front of the unit (on QL 320 and QL 420) or on the label on the back of the unit (on QL 320 Plus and QL 420 Plus).

QL 320 and QL 420 printers with the Frequency Hopping PCMCIA module can be identified by the text "Wireless Network Printer" and FCC ID: *128MD-QL3201* on the front of the unit.

Methods of establishing communications to QL Series printers will vary with each LAN application. General information on establishing WLAN communications can be found in either the "CPCL Programmers Manual" or the "Quick Start Guide for Mobile Wireless Printers" both available on-line at:

<http://www.zebra.com/manuals>

More information and LAN configuration utilities may also be found in Zebra's Label Vista™ program (version 2.8 and later). Label Vista may be downloaded from the Zebra Web site at:

http://www.zebra.com/SD/product_LabelVista.htm

continued

Setting Up the Software

QL Series printers use Zebra's CPCL Programming language which was designed for mobile printing applications. CPCL is fully described in the "CPCL Programmers Manual", available on-line from Zebra's Web site at:

<http://www.zebra.com/manuals>

You can also use Label Vista™, Zebra's Windows® based label creation program which uses a graphical interface to create and edit labels in the CPCL language. Label Vista is available on-line from Zebra's Web site at:

http://www.zebra.com/SD/product_LabelVista.htm

QL Series printers with an optional memory upgrade can support an interpreter for ZPL II®, or EPL programming languages. QL Plus Series printers have these interpreters loaded as a standard part of their operating system.

If you plan to use ZPL II or EPL, refer to the appropriate Programming Guides available on-line from Zebra's Web site. If you choose to use a third party label preparation system, follow the installation instructions included in the package.

Using the Accessories

Belt Clip

Refer to Figure 15. All QL Series printers are equipped with a belt clip as standard. To use: hook the clip over your belt, and ensure that the clip is securely attached to the belt. The belt clip will pivot to allow you to move freely while wearing the printer.

The retainer for the Belt Clip has a strain relief feature which can be used with the communications cable. Refer to the section on Connecting the Printer.

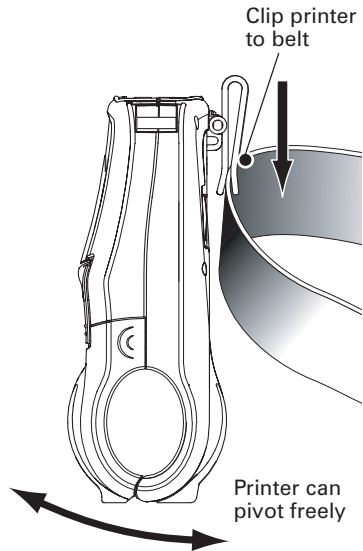

Figure 15: Using the Belt Clip

Kickstand

Refer to Figure 16. The Kickstand option allows users to use the printer on a desktop. To use the optional Kickstand: Flip the Kickstand on the back of the printer open until you feel a slight detent. The printer will now sit at approximately a 30° to 45° angle on a desktop depending on the printer model.

The retainer for the Kickstand has strain relief features which can be used with the communications cable. Refer to the section on Connecting the Printer.

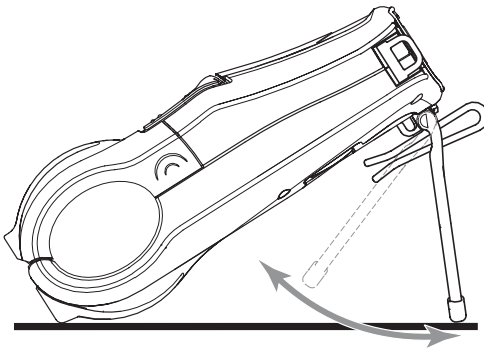
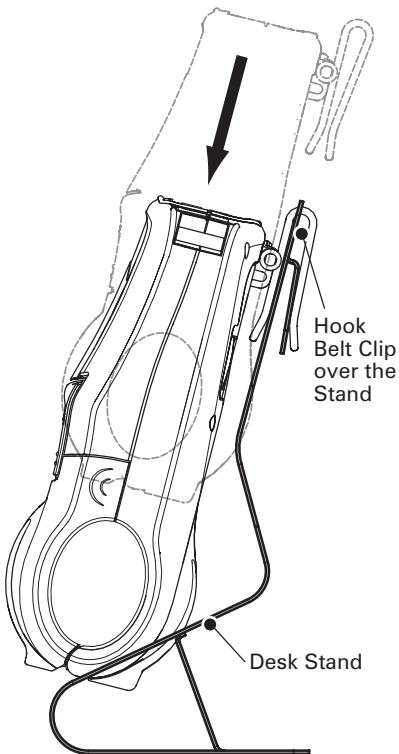

Figure 16: Using the Kickstand

Desk Stand



Refer to Figure 17. To use the Desk Stand: Slide the printer onto the Desk Stand. The printer's belt clip will hook onto the Desk Stand as shown and retain it in place. Ensure that the clip is securely attached to the Stand and the media compartment of the printer is seated securely in the Stand.

Refer to the Specifications section for Desk Stand part numbers.

Holes are provided to permanently attach the Desk Stand to the work surface. The charger and data I/O cables may be plugged into the printer in the usual manner.

Refer to the section on using the chargers for more information.

Figure 17: Using the Optional Desk Stand

Adjustable Shoulder Strap

Refer to Figure 18. If your printer is equipped for the shoulder strap option: snap each end of the shoulder strap into the "D" rings in the top of the printer. Slide the buckle away from or towards the printer until you achieve the desired length.

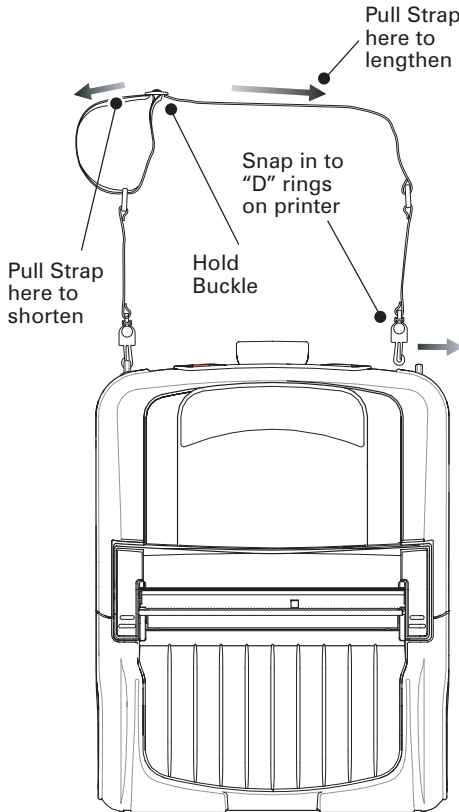

Figure 18: Using the Optional Shoulder Strap

continued

Carrying Strap

Refer to Figures 19 and 19a. There are two varieties of carrying strap. One of them clips onto the printer's "D" rings as does the shoulder strap, and the other is secured to the printer permanently with loops in the strap secured by sleeves captured between the printer's upper and lower covers.

Either strap provides the user with a convenient and secure method of carrying the printer.

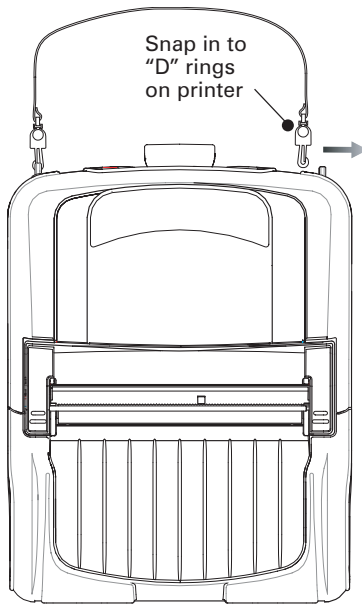

Figure 19: Detachable Carrying Strap

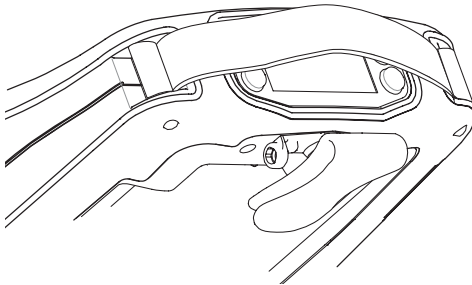

Figure 19a: Permanent Carrying Strap

Preventive Maintenance

Extending Battery Life

- Never expose the battery to direct sunlight or temperatures over 104° F (40° C).
- Always use a Zebra charger designed specifically for Lithium-Ion batteries. Use of any other kind of charger may damage the battery.
- Use the correct media for your printing requirements. An authorized Zebra re-seller can help you determine the optimum media for your application.
- If you print the same text or graphic on every label, consider using a pre-printed label.
- Choose the correct print darkness, and print speed for your media.
- Use software handshaking (XON/XOFF) whenever possible.
- Select Tear-Off mode whenever possible (Peel-Off mode uses more power).
- If your printer has the optional LCD display, use the display backlight only when necessary. Turn it off whenever it is not needed.
- Pull the battery out of the printer if the printer won't be used for a day or more and you're not performing a maintenance charge.
- Consider purchasing an extra battery.
- Remember that any rechargeable battery will lose its ability to maintain a charge over time. It can only be recharged a finite number of times before it must be replaced. Always dispose of batteries properly. Refer to Appendix D for more information on battery disposal.
- Don't print while the Model LI 72 Wall Charger is plugged into the unit. Unreliable battery charging can result.

Cleaning Instructions



CAUTION- Use only cleaning agents specified below. Zebra Technologies Corporation will not be responsible for damage caused by any other cleaning materials used on this printer.

Clean the printer with either the cleaning pen supplied with the printer or a cotton swab saturated with alcohol.



WARNING: To avoid possible personal injury or damage to the printer, never insert any pointed or sharp objects into the printer.

QL220 Cleaning

Area	Method	Interval
Printhead (Figure 20)	Use the supplied cleaning pen or 70% isopropyl alcohol on a cotton swab to clean the print elements from end to end (the print elements are located in the thin gray line on the printhead).	After every five rolls of media (or more often, if needed) Linerless media requires more frequent cleaning
Platen Roller (Figure 20)	Rotate the platen roller and clean it thoroughly with the cleaning pen or 70% isopropyl alcohol and a cotton swab.	
Platen Roller (Figure 20a)	Units with linerless platens: Rotate platen & clean bearing points only. <i>Avoid use of alcohol on the surface of linerless platens!</i>	
Peel bar (Figure 20)	Clean thoroughly with the cleaning pen or 70% isopropyl alcohol and a cotton swab.	As needed
Scraper (Linerless units only) Figure 20a	Clean thoroughly with the cleaning pen or 70% isopropyl alcohol and a cotton	After every five rolls of media (or more often, if needed)
Tear bar (Figure 20)	Clean thoroughly with the cleaning pen or 70% isopropyl alcohol and a cotton swab.	As needed
Exterior	Water-dampened cloth	
Interior (Figure 20)	Brush/air blow. Ensure the Bar Sensor, Gap Sensor and Label Present Sensor windows are free of dust.	
Interior (Figure 20a)	Units with linerless platens: Clean inside surfaces of Media supports & Media Support Disks with the supplied cleaning pen or 70% isopropyl alcohol on a cotton swab.	After every five rolls of media (or more often, if needed)

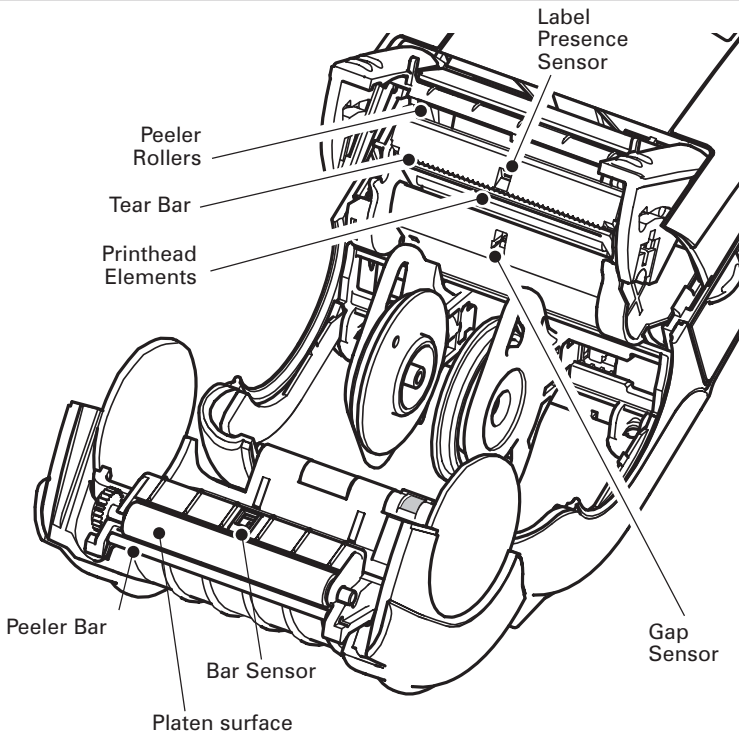

Figure 20: Cleaning the QL 220

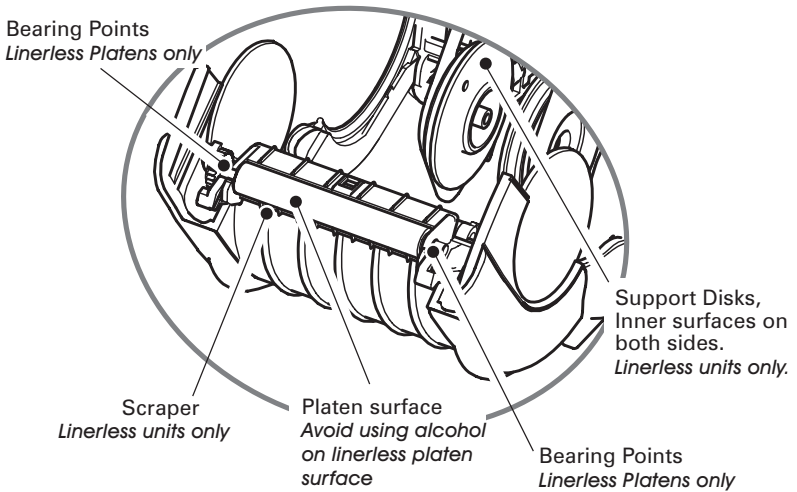

Figure 20a: Cleaning the Linerless QL 220

continued

QL 320 Cleaning

Area	Method	Interval
Printhead (Figure 21)	Use the supplied cleaning pen or 70% isopropyl alcohol on a cotton swab to clean the print elements from end to end (the print elements are located in the thin gray line on the printhead).	After every five rolls of media (or more often, if needed) Linerless media requires more frequent cleaning
Platen Roller (Figure 21)	Rotate the platen roller and clean it thoroughly with the cleaning pen or 70% isopropyl alcohol and a cotton swab.	
	Units with linerless platens: Rotate platen & clean bearing points only. <i>Avoid use of alcohol on the surface of linerless platens!</i>	
Peel bar (Figure 21)	Clean thoroughly with the cleaning pen or 70% isopropyl alcohol and a cotton swab.	As needed
Scraper, Linerless units only (Figure 21)	Clean thoroughly with the cleaning pen or 70% isopropyl alcohol and a cotton swab.	After every five rolls of media (or more often, if needed)
Tear bar (Figure 21)	Clean thoroughly with the cleaning pen or 70% isopropyl alcohol and a cotton swab.	As needed
Exterior	Water-dampened cloth	
Interior (Figure 21)	Brush/air blow. Ensure the Bar Sensor, Gap Sensor and Label Present Sensor windows are free of dust.	
	Units with linerless platens: Clean inside surfaces of media disks & peeler bar rollers with the supplied cleaning pen or 70% isopropyl alcohol on a cotton swab.	After every five rolls of media (or more often, if needed)

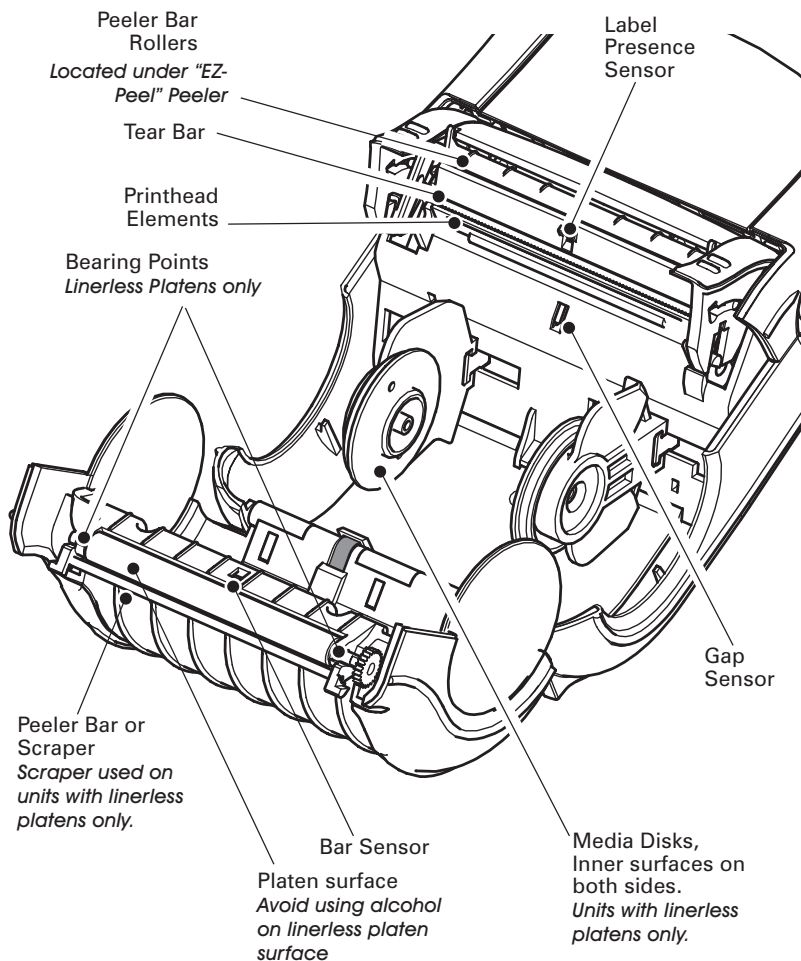

Figure 21: Cleaning the QL 320

continued

QL 420 Cleaning

Area	Method	Interval
Printhead (Figure 22)	Use the supplied cleaning pen or 70% isopropyl alcohol on a cotton swab to clean the print elements from end to end (the print elements are located in the thin gray line on the printhead).	After every five rolls of media (or more often, if needed) Linerless media requires more frequent cleaning
Platen Roller (Figure 22)	Rotate the platen roller and clean it thoroughly with the cleaning pen or 70% isopropyl alcohol and a cotton swab.	
		Units with linerless platens: Rotate platen & clean bearing points only. <i>Avoid use of alcohol on the surface of linerless platens!</i>
Peel bar (Figure 22)	Clean thoroughly with the cleaning pen or 70% isopropyl alcohol and a cotton swab.	As needed
Scraper, Linerless units only (Figure 22)	Clean thoroughly with the cleaning pen or 70% isopropyl alcohol and a cotton	After every five rolls of media (or more often, if needed)
Tear bar (Figure 22)	Clean thoroughly with the cleaning pen or 70% isopropyl alcohol and a cotton swab.	As needed
Exterior	Water-dampened cloth	
Interior (Figure 22)	Brush/air blow. Ensure the Bar Sensor, Gap Sensor and Label Present Sensor windows are free of dust.	After every five rolls of media (or more often, if needed)
	Units with linerless platens: Clean inside surfaces of edge guides & media rollers with the supplied cleaning pen or 70% isopropyl alcohol on a cotton swab.	
Media Rollers (Figure 22)	Clean thoroughly with the cleaning pen or 70% isopropyl alcohol and a cotton swab.	After every five rolls of media (or more often, if needed)
	Units with linerless platens: Rotate media rollers & clean bearing points only. <i>Avoid use of alcohol on the surface of the media rollers!</i>	

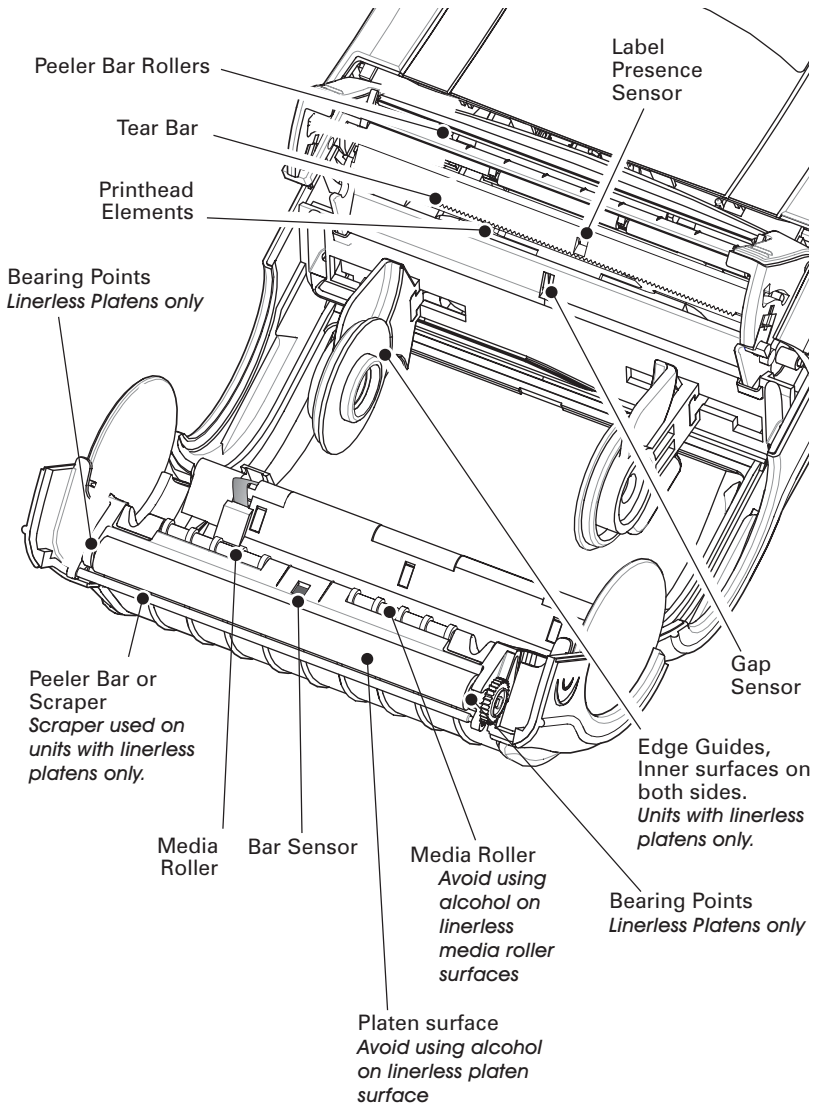

Figure 22: Cleaning the QL 420

Troubleshooting







Standard Control Panel

If the printer is not functioning properly, refer to the chart below to find the state of the two LEDs on the Control Panel. Then refer to the Troubleshooting topic referenced in the chart to resolve the problem.

Green LED	Yellow LED	Indication	Ref. to Topic
Steady	Off	Normal Operation, and/or RF Link established	n/a
Off	Off	Power Off	1
Fast Blink	Off	No RF Link	6, 11
Slow Blink	Off	Low Battery	3, 6, 7
Steady	Steady	Out of media, or Media Cover not closed	9, 11
Steady	Fast Blink	Normal RF activity	8
Steady	Fast Blink, Beeper Sounds	No application	8

Optional LCD Control Panel

The top of the display shows several icons which indicate various printer functions. Check the indicator status, then refer to the Troubleshooting topic referenced in the chart to resolve the problem.

Status Icon	Condition	Indication	Ref. to Topic
	Steady	Bluetooth Link established	n/a
	Flashing	Data transmission via Bluetooth	n/a
	Off	No Bluetooth link	6
	Steady	RF Link established	n/a
	Off	No RF Link	6
	Flashing	Low Battery	3, 6, 7
	Flashing	Head latch not closed	9, 11
	Flashing	Printer is receiving a file	8
	Flashing	Out of media	9, 11
Blank Screen	n/a	No application	1,13

Troubleshooting Topics

1. No power

- Check that battery is installed properly.
- Recharge or replace battery as necessary. Always dispose of batteries properly. Refer to Appendix D for more information on proper battery disposal.

2. Media does not feed:

- Be sure print head is closed and latched.
- Check spindle holding media for any binding.
- If unit is equipped with label presence sensor: Ensure most recently printed label is removed. Also ensure label sensor is not blocked.

3. Poor or faded print or flashing:

- Clean print head.
- Check battery and recharge or replace as necessary. Always dispose of batteries properly. Refer to Appendix D for more information on proper battery disposal.
- Check quality of media.

4. Partial/missing print:

- Check media alignment
- Clean print head.
- Ensure printhead is properly closed and latched.

5. Garbled print:

- Check baud rate.

6. No print:

- Check baud rate.
- Replace battery. Always dispose of batteries properly. Refer to Appendix D for more information on proper battery disposal.
- Check cable to terminal.
- Establish RF Link (Wireless units only) and/or restore LAN associativity (Printers with WLAN radios only).
- Invalid label format or command structure — put printer in Communications Diagnostic (Hex Dump) Mode to diagnose problem.

7. Reduced battery charge life

- Check battery date code — if battery is one to two years old, short charge life may be due to normal aging.
- Recondition battery.
- Replace battery. Always dispose of batteries properly.

continued

Refer to Appendix D for more information on proper battery disposal.

8. Yellow error light or  flashing:

- No application or application corrupted: reload program.
- If using wireless communications: flashing indicator is normal while data is being transmitted or received.

9. Yellow error light always on,  or  flashing:

- Check that media is loaded and that the print head is closed and securely latched.

10. Skips labels:

- Check media for top of form sense mark or label gap.
- Check that the maximum print field has not been exceeded on label.
- Ensure bar or gap sensor is not blocked or malfunctioning

11. Communication error:

- Check media is loaded, head is closed and error light is off.
- Check baud rate.
- Replace cable to terminal.

12. Label jam:

- Open head release latch and media cover.
- Generously apply alcohol to printer in area of jammed label.

13. Blank LCD screen (only for units with optional LCD control panel)

- No application loaded or application corrupted: reload program.

Troubleshooting Tests

Printing a Configuration Label

To print out a listing of the printer's current configuration follow these steps:

1. Turn the printer off. Load the media compartment with journal media (media with no black bars printed on the back)
2. Press and hold the Feed Button.
3. Press and release the Power button and keep the Feed button pressed. When printing starts, release the Feed button.

Refer to Figures 22 and 23 for a sample configuration print-out.

Communications Diagnostics

If there's a problem transferring data between the computer and the printer, try putting the printer in the Communications Diagnostics Mode (also referred to as the "DUMP" mode). The printer will print the ASCII characters and their text representation (or the period '.', if not a printable character) for any data received from the host computer

To enter Communications Diagnostics Mode:

1. Print a configuration label as described above.
2. At the end of 2nd diagnostics report, the printer will print: "Press FEED key to enter DUMP mode".
3. Press the FEED key. The printer will print: "Entering DUMP mode".



NOTE: If the FEED key is not pressed within 3 seconds, the printer will print "DUMP mode not entered" and will resume normal operation.

4. At this point, the printer is in DUMP mode and will print the ASCII hex codes of any data sent to it, and their text representation (or "." if not a printable character).

Additionally, a file with a ".dmp" extension containing the ASCII information will be created and stored in the printer's memory. It can be viewed, "cloned" or deleted using the Label Vista application. (Refer the Label Vista documentation for more information.)

To terminate the Communications Diagnostics Mode and return the printer to normal operations:

continued

-
1. Turn the printer OFF.
 2. Wait 5 seconds.
 3. Turn the printer ON.

Calling Technical Support

If the printer fails to print the configuration label, or you encounter problems not covered in the Troubleshooting Guide, contact Zebra Technical Support. Technical Support addresses and phone numbers for your area can be found in Appendix D of this manual. You will need to supply the following information:

- Model number/type (e.g. QL 420)
- Unit serial number (Found on the large label on the back of the printer, also found in the configuration label print-out. Refer to Figures 22 and 23)
- Product Configuration Code (PCC) (15 digit number found on the small label on the back of the unit)

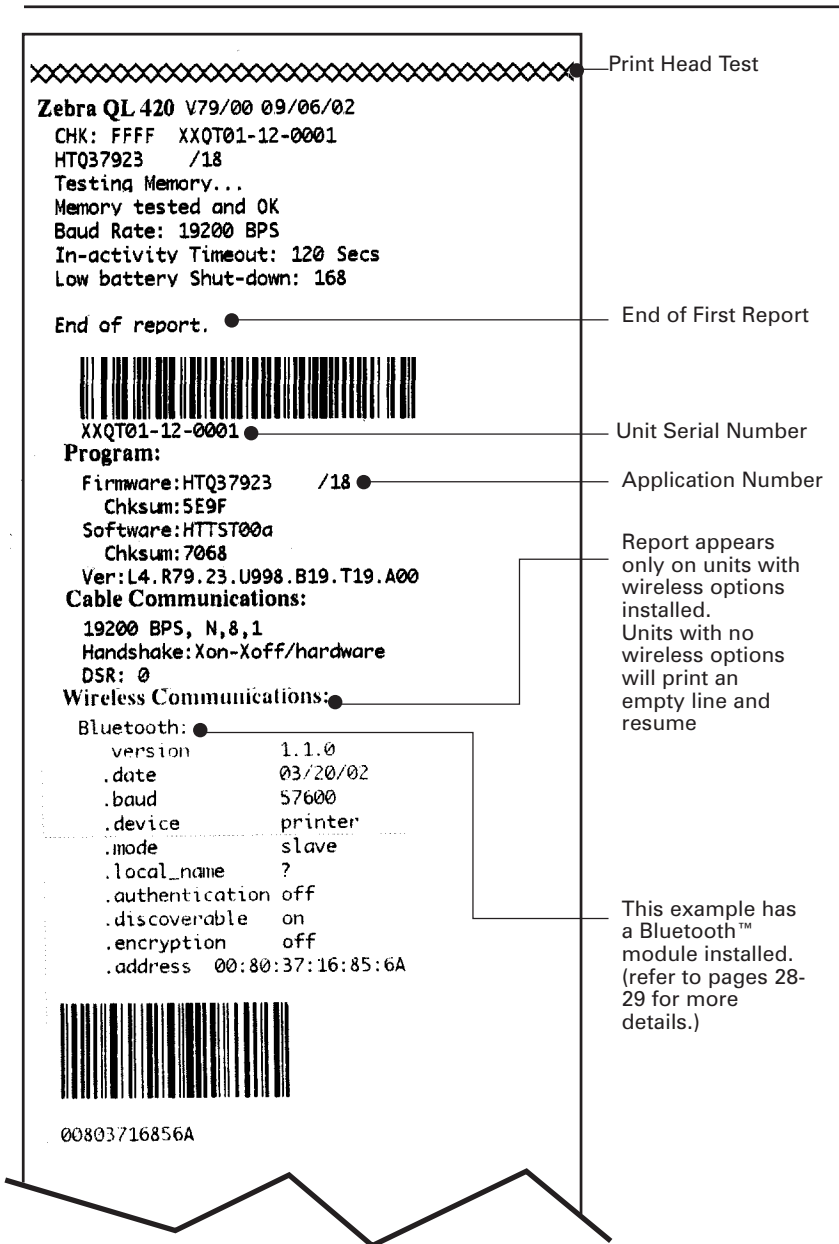

Figure 23: Configuration Label Example (QL 420 illustrated)

continued

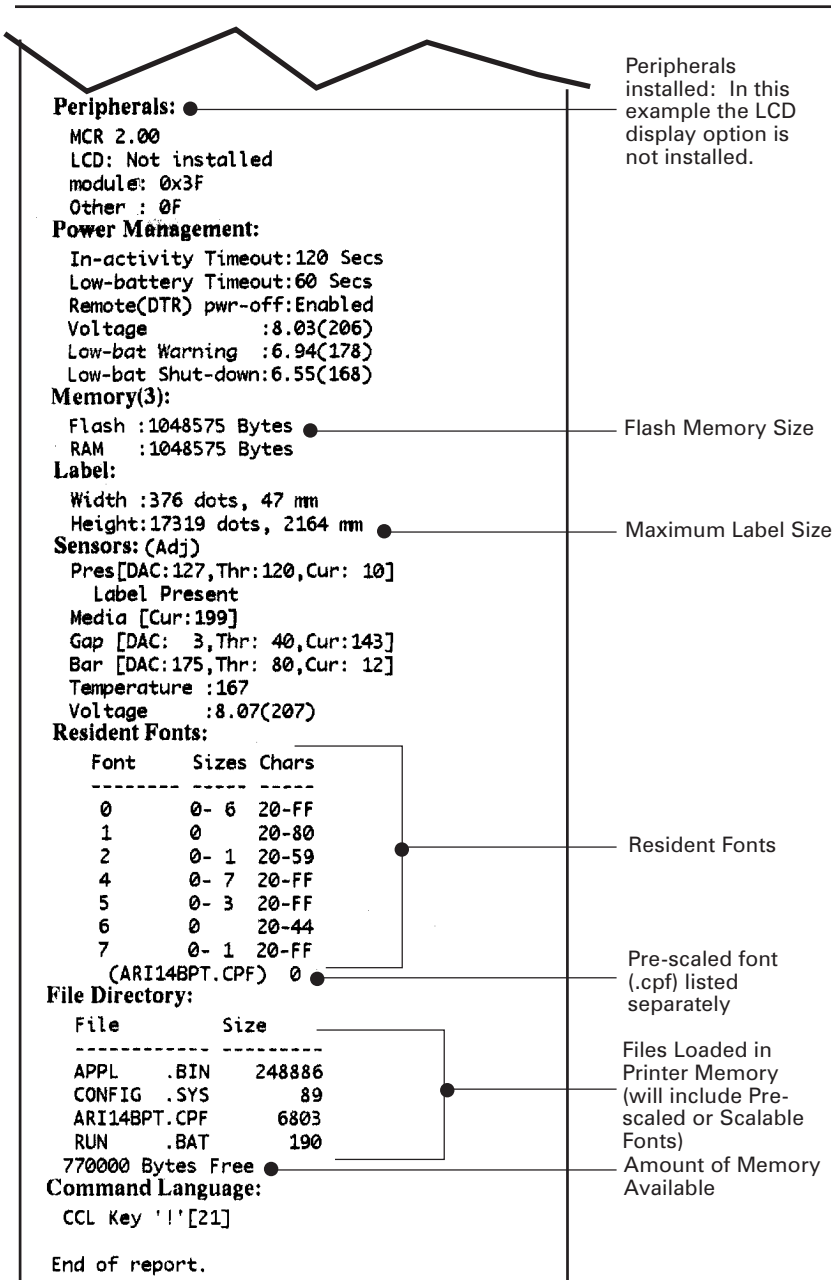

Figure 23a: Configuration Label Example (continued)

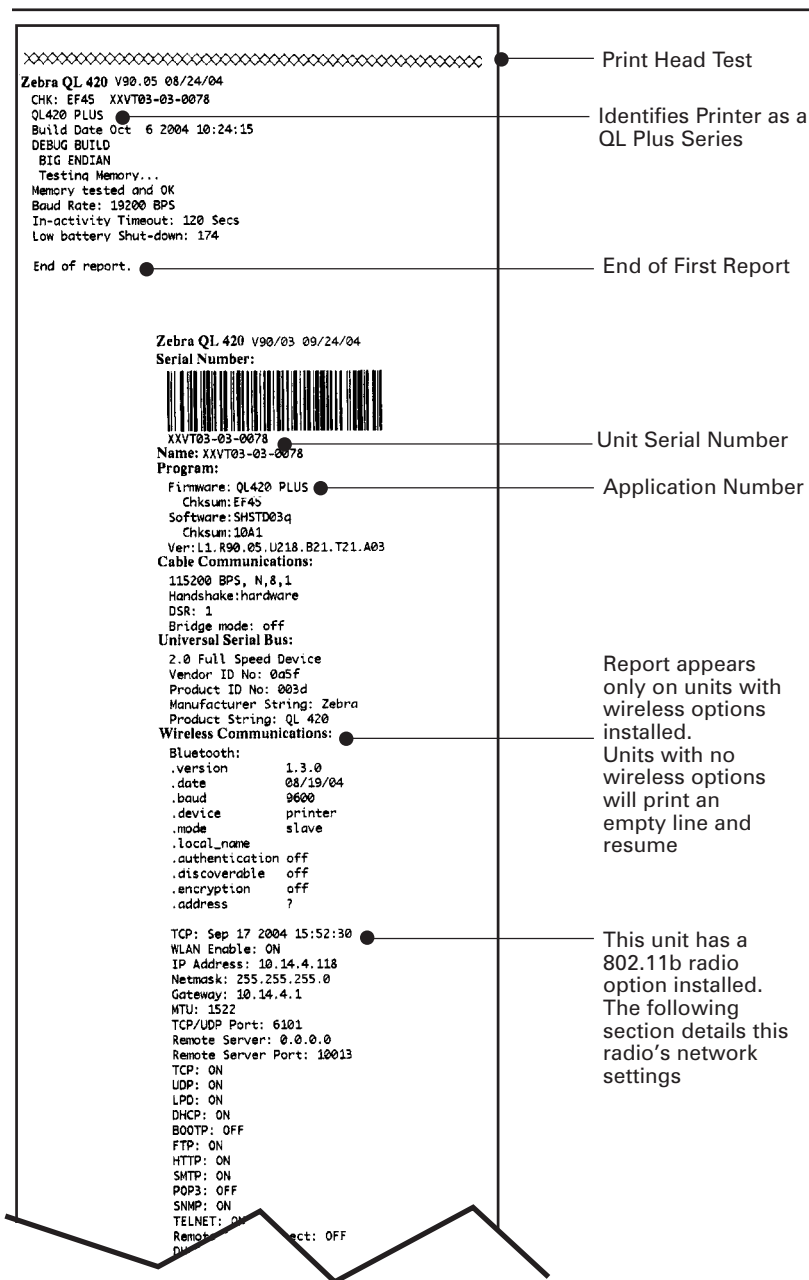
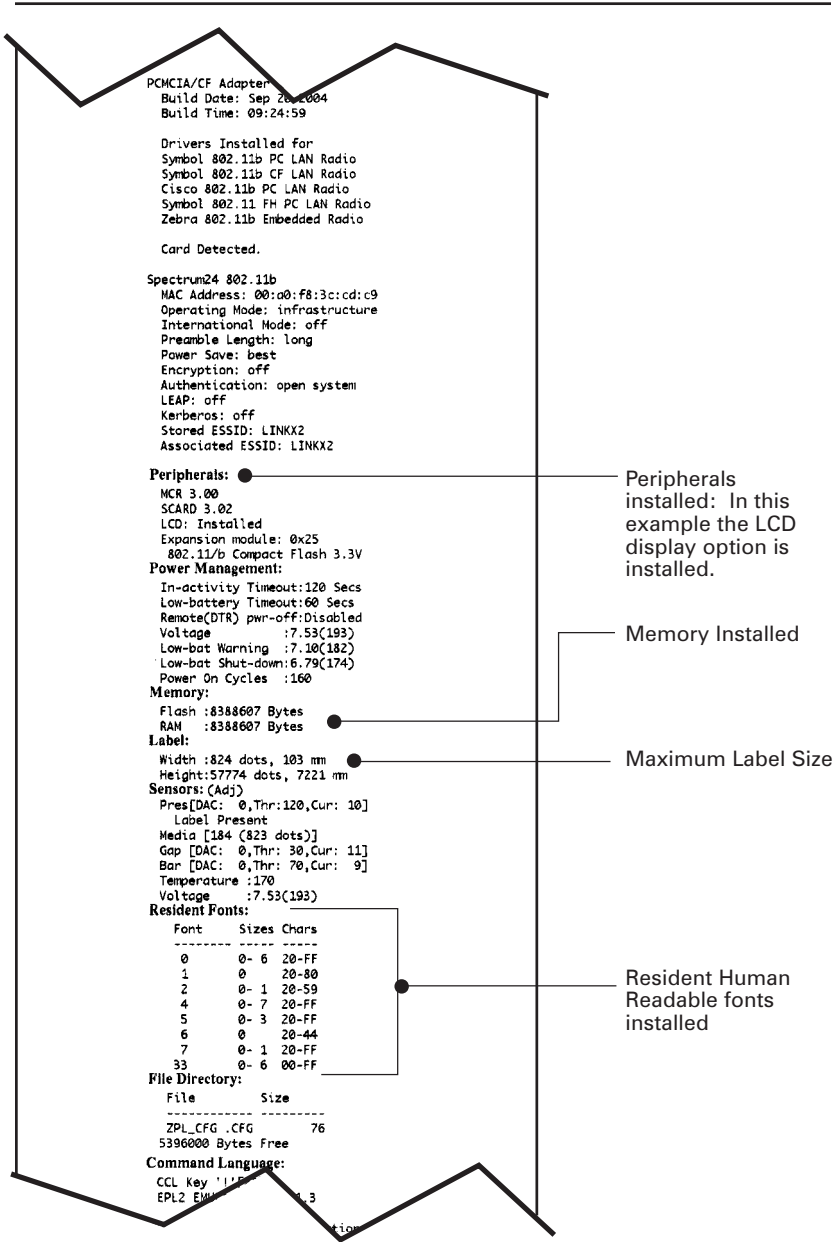

Figure 24: QL Plus Configuration Label Example



Peripherals installed: In this example the LCD display option is installed.

Memory Installed

Maximum Label Size

Resident Human Readable fonts installed

Figure 24a: QL Plus Configuration Label Example (continued)

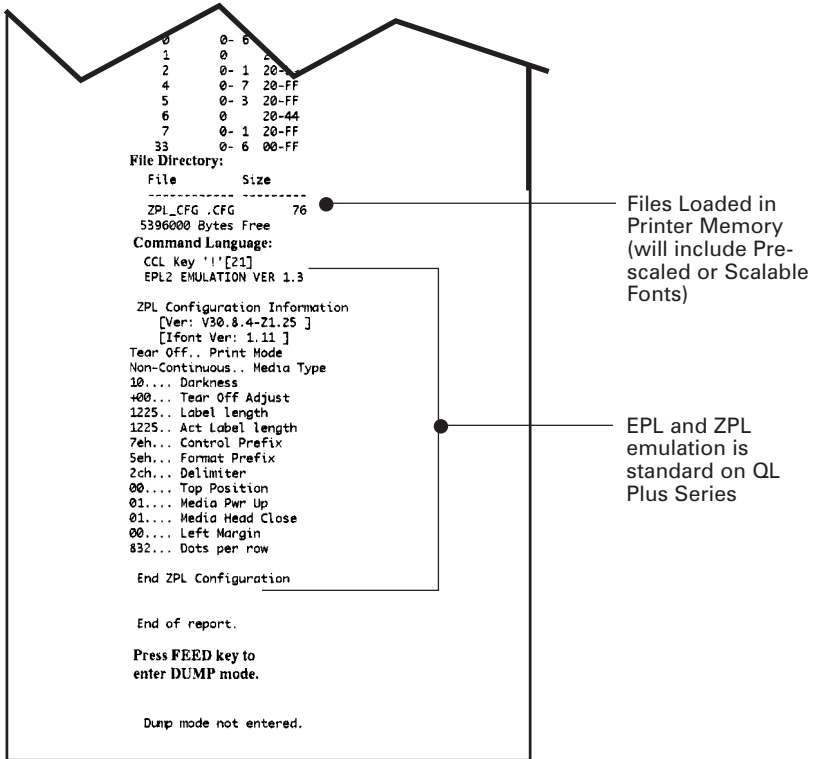

Figure 24b: QL Plus Configuration Label Example (continued)

Specifications



NOTE. - Printer specifications are subject to change without notice.

Printing Specifications

	QL220/220 Plus	QL320/320 Plus	QL420/420 Plus
Print Width	Up to 1.89 in. (48 mm)	Up to 2.9 in. (71.2 mm)	Up to 4.09 in. (103.8 mm)
Print Speed	3" per second (76.2 mm/second)	4" per second (101.6 mm/second)	3" per second (76.2 mm/second)
Distance from Print Element to Top of Form	.445 in. (11.3mm) 89 dots	.571 in. (14.5 mm) 116 dots	.571 in. (14.5 mm) 116 dots
Print Head Life, calculated	1,964,160 in. (50 Km) nominal		
Print Density	203 dots/inch (8 dots/mm)		

Memory/Communications Specifications

QL Series Flash Memory RAM Memory	1 MB Flash (standard); 2 MB flash (optional) 1MB RAM (standard); 2 MB RAM (optional)
QL Plus Series Flash Memory RAM Memory	4 MB flash (standard) 8 MB RAM (standard)
Standard Communications (all models)	RS-232 serial port (8 Pin circular DIN connector) Configurable Baud rate (from 9600 to 57.6 Kbps), parity and data bits. Software (X-ON/X-OFF) or hardware (DTR/STR) communication handshake protocols.
QL Plus Series only	USB 2.0 Full Speed Interface (12 Mbps)
Optional Wireless Communications (all models)	Infrared wireless link meets IrDA 1.1 communications specifications 2,400 to 115,200 Baud rate Bluetooth compatible 2.4 GHz SRRF link Optional wireless LAN capabilities comply with 802.11 and 802.11b protocols

Label Specifications

	QL220/220 Plus	QL320/ 320 Plus	QL420/420 Plus
Label/Tag Width	.75 in. to 2.12 in. (16 to 53.8 mm)	1.5 in. to 3.1 in. (38.1 to 78.4 mm)	2 in. to 4.1 in. (50.8 to 104.1 mm)
Max. Label/ Tag Length (w/std. memory)	20 in. (508 mm)	16 in. (406.4 mm)	20 in. (508 mm)
Inter-label Gap.	0.08 in. to 0.16 in. (.12 in. preferred) (2 mm to 4 mm [3 mm preferred])		
Label Thickness	.0025 in to .0065 in (.064 mm to .165 mm)		
Tag Thickness	.0060 in. (.152 mm) maximum		
Max. Label Roll dia.	2.2" (55.9 mm) O.D	2.625 in. (66.7 mm) O.D.	
Label Inner Core	0.75 in. (19 mm) minimum dia; 1.38 in. (35.05 mm) minimum dia for linerless media (QL420 accepts linerless media on 0.75 in. cores.)		
Black Mark Dimensions	The reflective media black marks should extend past the centerline of the roll.		
Media Requirements	Minimum mark width: 0.5 in. (12.7mm) perpendicular to edge of media, centered within the width of the roll. Mark length: 0.094 in. (2.4 mm) parallel to edge of media		

Use Zebra brand direct thermal media that is outside wound. Media may be reflective (black mark) sensing, or transmissive (gap) sensing, die-cut, continuous, or linerless. QL 420 models will accept fanfold media if used with an external media supply. For die-cut labels, use only full auto dies.

Font/Bar Code Specifications for QL Series

Fonts Available	Five resident scalable and rotatable fonts available from 12-48 pt. Downloadable pre-scaled fonts via Label Vista software. Optional international character sets
Linear Bar Codes Available	Codabar UCC/EAN 128 Code 39 Code 93 EAN 8/JAN 8, 2 and 5 digit extensions EAN 13/JAN 13, 2 and 5 digit extensions Interleaved 2 of 5 MSI/Plessey FIM/POSTNET UPC-A, 2 and 5 digit extensions UPC E, 2 and 5 digit extensions
2D Bar Codes Available	MaxiCode PDF 417
Rotation Angles	0°, 90°, 180°, and 270°

Font/Bar Code Specifications for QL Plus Series

Fonts Available	Standard Fonts: 25 bit-mapped fonts; 1 scalable font (CG Trimvirate Bold Condensed*) Downloadable optional bit-mapped & scalable fonts via Label Vista software. Optional International character sets: Chinese 16 x 16 (trad), 16 x 16 (simplified), 24 x 24 (simplified); Japanese 16 x 16, 24 x 24; Hebrew/Arabic *contains UFST from Agfa Monotype Corporation
Linear Bar Codes Available	Same as QL Series, plus: EAN-8 Composite EAN-13 Composite UPCA Composite UPCE Composite
2-D Bar Codes Available	Same as QL Series, plus: Datamatrix (using ZPL emulation) RSS: RSS-14 Truncated RSS-14 Stacked RSS-14 Stacked Omnidirectional RSS Limited RSS Expanded
Rotation Angles	0°, 90°, 180°, and 270°

Communications Ports

RS232C

Signal			
Pin#	Name	Type	Description
1	RXD	input	Receive Data
2	TXD	output	Transmit Data
3	CTS	input	Clear To Send from host
4	RTS	output	Request To Send set high when printer is ready to accept a command or data
5	GND		Ground
6	NC		No Connect
7	DSR	input	Data Set Ready low to high transition turns printer on, high to low transition turns printer off (if enabled)
8	DTR	output	Data Terminal Ready set high when printer is on. Set to battery voltage for "S" versions(compatible with Symbol™ PIM)

USB (QL Plus Series only)

Signal			
Pin#	Name	Type	Description
1	VBUS	-	USB Bus Power
2	USB -	bi-directional	I/O signals
3	USB +	bi-directional	I/O signals
4	USB_ID	-	Identifies A/B connector
5	Return		Ground

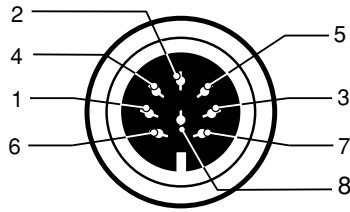

Figure 25: RS232C Communications Port (8 pin Circular DIN)

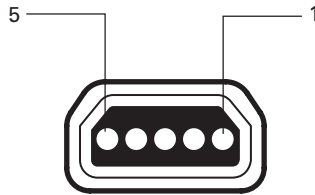

Figure 26: USB Communications Port (QL Plus Series only)

Physical/Environmental/Electrical Specifications

	QL 220/220 Plus	QL 320/320 Plus	QL 420/420 Plus
Weight w/ battery, excluding media & wireless options.	1.1 lbs. (.50 kg.)	1.65 lbs. (.75 kg.)	2.0 lbs. (.9 kg.)
Temperature	Operating: 5° to 122° F (-15° to 50° C) Storage: -13° to 158° F (-25° to 70° C) Range		
Relative Humidity	Operating: 10% to 80% (non-condensing) Storage: 10% to 90% (non-condensing)		
Battery	7.4V (nominal) Lithium-Ion		
Chargers:	External single battery charger Model LI72, 120-230 VAC depending on model selected. External 4-bay charger Model UCLI72-4, 100-240 VAC		

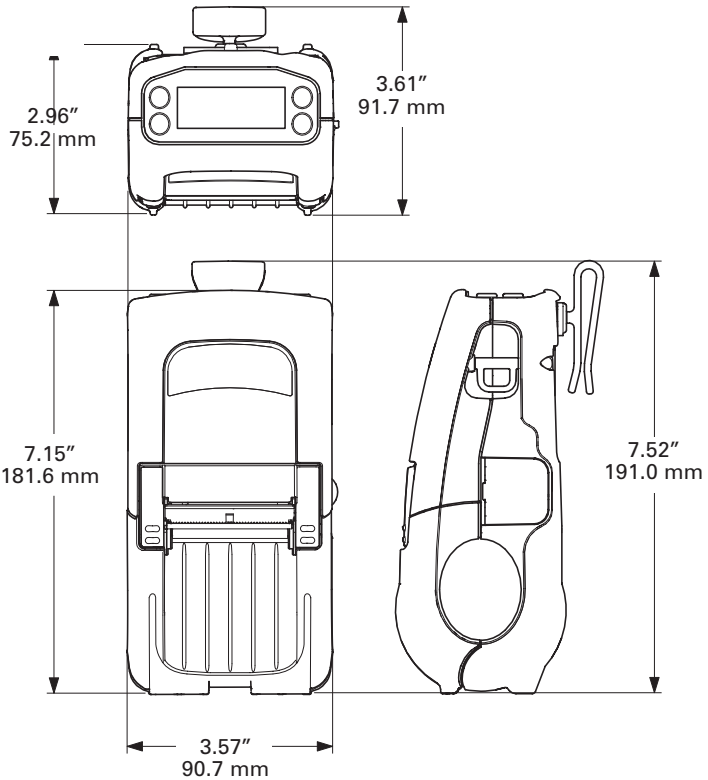

Figure 27: QL 220 Overall Dimensions

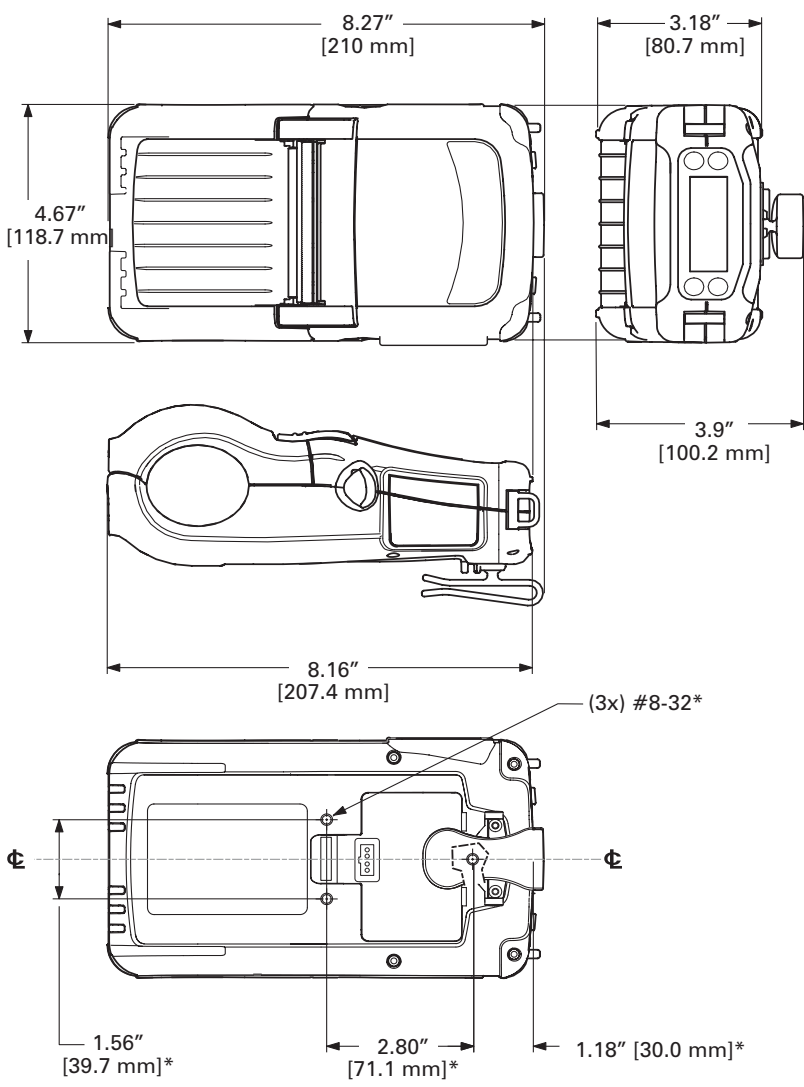

Figure 28: QL 320 Overall Dimensions



NOTES 1. QL 320 plus is illustrated. Dimensions with an asterisk (*) are for QL 320 plus only; all other dimensions are identical for both QL 320 models.

2. Belt Clip must be removed to use all three mounting holes on the bottom of the QL 320 plus.

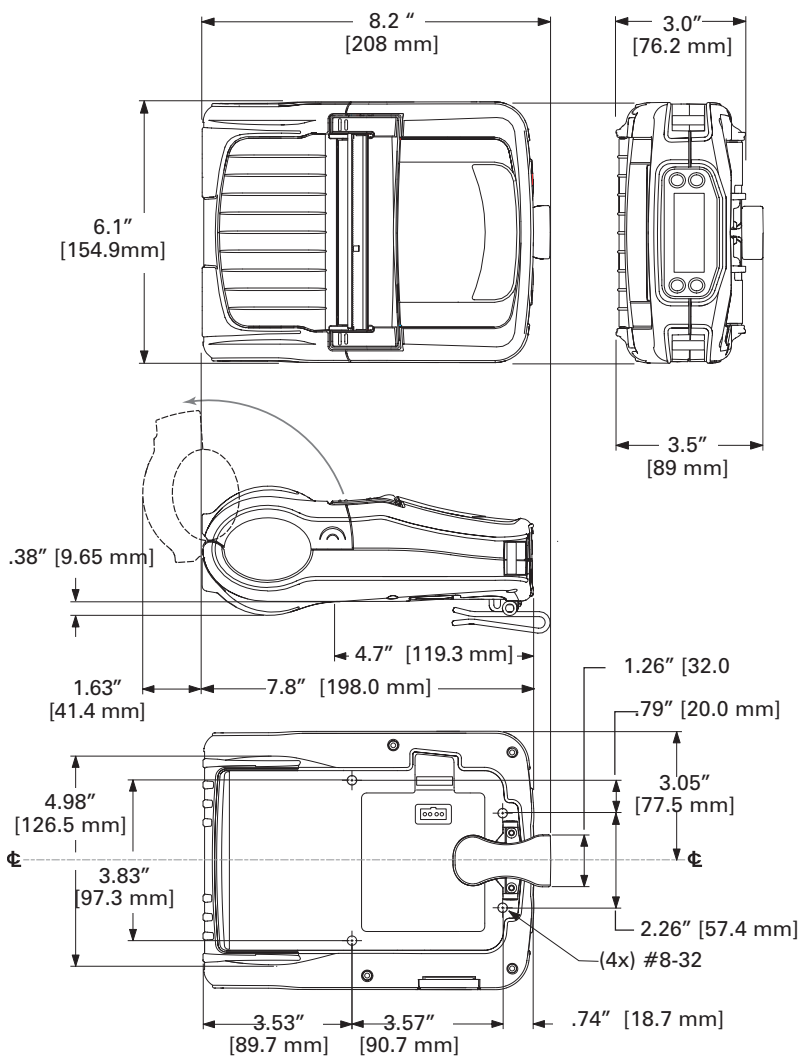

Figure 29: QL 420 Overall Dimensions

QL Series Accessories

Description	QL 220/ 220 Plus	QL 320/ 320 Plus	QL 420/ 420 Plus
Adjustable shoulder strap	•	•	•
Carrying Strap	•	•	•
Protective soft case	•	•	•
Extra battery packs	•	•	•
Desk Stand	•	•	•
Kickstand	•	•	•
Handi-Mount articulated arm and mounting plate			•
Model MM Q4 Vehicular Mount w/ external fanfold media storage			•
Model RCLI-DC Mobile Chargers DC-DC run/charge units (input ranges from 12 to 60 VDC)	•	•	•
Model RCLI-AC Mobile Charger- AC run/charge unit (100 to 240 VAC input)	•	•	•
Model LI 72- Single Battery Charger 120-230 VAC	•	•	•
Model UCLI72-4-Quad Battery Charger 100-240 VAC	•	•	•

Refer to Appendix A for information on Data I/O Cables

Appendix A

Interface Cables

RS232 Cables

Part Number BL11757-000; 8-Pin DIN to 9-Pin DB PC Cable (For Use With a Personal Computer)

This part is also available as a coiled cable under Part Number BL15063-1.

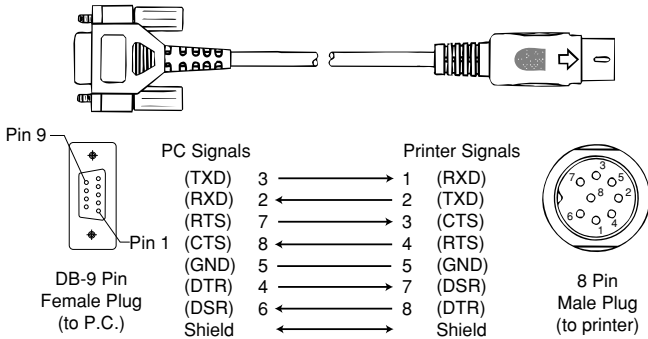

Part Number BL16555-1 (Molded Right Angle DIN Housing to 9-Pin DB)

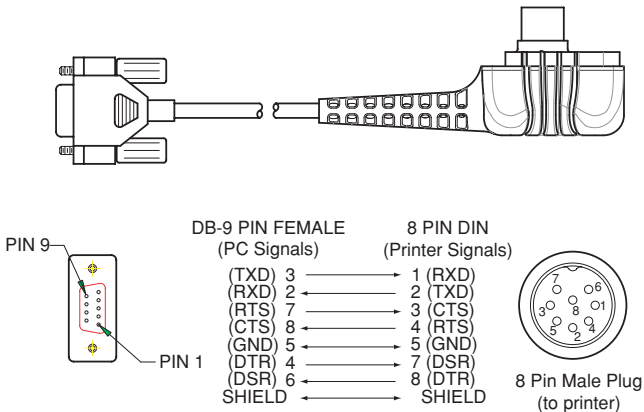

USB Cable (QL Plus Series only)

Part Number AT17010-1; USB A to USB Mini B Cable

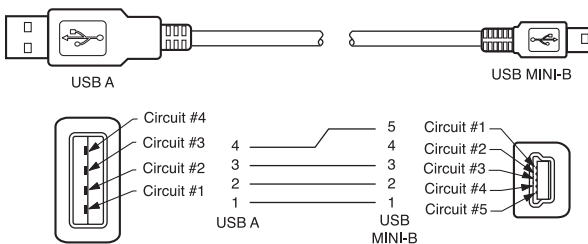

Appendix A

INTERFACE CABLES

Terminal	Cable Part Number	Cord Lgth/Type	Terminal Connector	Printer Connector	Notes
COMPSEE					
Apex II, III	BL12093-3	8' Coiled	MOD 10	8 Pin DIN	
COMPAQ (IPAQ)					
H3100, H3600, H3700	BL16386-1	4' straight	Foxconn 12 pin	8 Pin DIN	
H3800	BL16470-1	4' straight	Foxconn 22 pin	8 Pin DIN	
HANDHELD PRODUCTS					
7500, 7506	BL11757-000	6'/Straight	9 Pin DB	8 Pin DIN	
LXE					
MX1, MX3	BL17757-000	6'/Straight	9 Pin DB	8 Pin DIN	
1380, 1390, 1590	BL17757-000	6'/Straight	9 Pin DB	8 Pin DIN	
2325	BL12093-1	8'/Coiled	RJ45	8 Pin DIN	Power On/Off (+5V)
MISCELLANEOUS					
	BL16302-00	6'/straight	unterminated	8Pin DIN	
	BL16830-00	6'/straight	unterminated	8Pin DIN rt. angle	
	BL16900-00	8'/coiled	unterminated	8Pin DIN rt. angle	
	BL16713-1	1'/ straight	1/4" phone jack/DEX	8Pin DIN rt. angle	
NORAND/INTERMEC					
RT1100/1700 Series	BL11537-1	8' /Coiled	6 Pin MiniDIN	8 Pin DIN Over-molded	
	BL11537-2	12'/Coiled	6 Pin MiniDIN	8 Pin DIN Over-molded	
	BL13309-1	8' /Coiled	6 Pin Mini DIN	8Pin DIN	Auto ON/OFF
RT1700 Series	BL12804-1	8' /Coiled	6 Pin MiniDIN	8 Pin DIN -Locking	
	BL13298-1	8' /Coiled	6 Pin MiniDIN	8 Pin DIN Over-molded	Auto ON/OFF
RT5900 Series	BL112803-1	8' /Coiled	15 Pin D-Sub	8 Pin DIN	
6400	BL11757-000	6'/Straight	9 Pin DB	8 Pin DIN	
242X	BL11757-000	6'/Straight	9 Pin DB	8 Pin DIN	w/optical link adapter Intermec#
064021					
243X	BL11757-000	6'/Straight	9 Pin DB	8 Pin DIN	no auto power
	BL11537-1	8'/coiled	6 pin Mini DIN	8 pin DIN	
	BL11537-2	12'/coiled	6 pin Mini DIN	8 pin DIN	

Appendix A

INTERFACE CABLES (continued)

Terminal	Cable Part Number	Cord Lgth/Type	Terminal Connector	Printer Connector	Notes
502X	BL11757-000	6'/Straight	9 Pin DB	8 Pin DIN	w/ intermed serial adapter
6110	BL11757-000	6'/Straight	9 Pin DB	8 Pin DIN	w/ serial pod
6640,665x,	BL11757-000	6'/Straight	9 Pin DB	8 Pin DIN	
248x	BL11757-000	6'/Straight	9 Pin DB	8 Pin DIN	COM1
5055	BL11757-000	6'/Straight	9 Pin DB	8 Pin DIN	Auto Power (DTR)
PSC					
Falcon 310,315	BL12093	8'/coiled	MOD 10	8 Pin DIN	Auto Power (+5V)
320, 325	CL16894-1	8'/coiled	MOD 10	8 Pin DIN rt. angle	Auto Power (+5V)
PT2000, TopGun	BL13285-1	8' coiled	DB15	8 Pin DIN	
Falcon 510,515,	BL11757-000	6'/Straight	9 Pin DB	8 Pin DIN	Auto Power (DTR)
625,665					
SYMBOL/TELXON					
FMT 1000, 3000	BL11757-000	6'/Straight	9 Pin DB Fem.	8 Pin DIN	Auto Power (DTR)
PDT3300 Series	BL11391-000	8' /Coiled	DB25 male	8 Pin DIN	Auto Power (DTR)
	BL12093-2	8' coiled	MOD 10	8 Pin DIN	Auto Power (+5V)
	CL16894-1	8'/coiled	MOD 10	8 Pin DIN rt. angle	Auto Power (+5V)
PDT3100, 3200, 3500	BL12093-1	8' /Coiled	MOD 10	8 Pin DIN	Auto Power(+5V)
6100	BL10293-2	8' /Coiled	MOD 10	8 Pin DIN	Auto Power(DTR)
SPT1700, 1800	BL15483-1	9' /Coiled	Clip-on	8 Pin DIN	
	BL15483-3	9' /Coiled	Clip-on	8 Pin DIN	Auto Power Pin 1 (+5 V)
PPT2700, 2800	BL15482-1	9' /Coiled	Cradle	8 Pin DIN	Power On/Off (DTR Line)
PDT3100, 3200	CL16894-1	8'/coiled	MOD 10	8 Pin DIN rt. angle	Auto Power(+5V)
3500,6100	BL12093-1	8'/coiled	MOD 10	8 Pin DIN	Auto Power (+5V)
	BL12093-2	8'/coiled	MOD 10	8 Pin DIN	Auto Power (DTR)
	CL16894-1	8'/coiled	MOD 10	8 Pin DIN rt. angle	Auto Power (+5V)
	CL16894-2	8'/coiled	MOD 10	8 Pin DIN rt. angle	Auto Power (DTR)
PDT3800, 6800	CC11371-3	6' /Coiled	PIM LPT	8 Pin DIN	
	CC11371-14	6' / Coiled	PIM COM	8 Pin DIN	
	CC11371-15	6' / Coiled	PIM COM	8 Pin DIN	Auto Power (DTR)

Appendix A

INTERFACE CABLES (continued)

Terminal	Cable Part Number	Cord Lgth/Type	Terminal Connector	Printer Connector	Notes
PDT8100	BL1656-1	8' / coiled	clip on	8 Pin DIN	Auto Power (DTR)
LRT/LDT3800 & 6800 Series	CC11371-14	6' / Coiled	PIM LPT	8 Pin DIN	"S" Printers Only
LRT/LDT3800 & 6800 Series	CC11371-15	6' / Coiled	PIM Optical	8 Pin DIN	"S" Printers Only
PTC960X	BL11122-1	8' / Coiled	MOD 8	8 Pin DIN	Auto Power (DTR)
PTC960L, 960SL	CC17711-1	n/a	Micro DB-15		Adapter for BL11122-1
960RL, 960M, 1134 2134, 2234	CP74005	8' / Coiled	Micro DB-15	8 Pin DIN	BL11122-1 & CC13711-1 (Kit)
PTC 510, 610, 710 860, 912	CL11314-000	8' / Coiled	DB25F	8 Pin DIN	Auto Power (DTR)
PTC 860IM, 870IM	BL13237-1	6' / Straight	Fischer-11	8 Pin DIN	Auto Power (DTR)
PTC1124, 2124	BL11757-000	6' / Straight	DB-9M	8 Pin DIN	uses serial pod
PTC1184	CL12628-1	8' / Coiled	Mini DIN-8F	8 Pin DIN	
PTC1194	BL11757-000	6' / Straight	DB-9M	8 Pin DIN	Auto-power (DTR)
VRC 3900	CL11314-000	8' / Coiled	DB-25F	8 Pin DIN	Auto Power (DTR)
VRC4000,5000	BL11757-000	6' / Straight	DB-9M	8 Pin DIN	Auto Power (DTR)
VRC 69XX	BL16014-1	10' / Straight	Fischer-16	8 Pin DIN	
VRV7900,8900	CL16840-1	6' straight	Ampenol 7	8 Pin DIN rt. angle	No Auto-power
TEKLOGIC					
7025	BL13285-1	8' / Coiled	DB-15M	8 Pin DIN	
7030	BL13285-2	8' / Coiled	Honda-36M	8 Pin DIN	Auto Power (7.5V)
7035	BL16469-1	8' / Coiled	Honda-28M	8 Pin DIN	Auto Power (7.5V)
8255, 8260	BL16469-1	8' / Coiled	Honda-28M	8 Pin DIN	Auto Power (12V)
8510	BL11757-000	6' / Straight	DB-9M	8 Pin DIN	Auto-power (DTR)
UNITECH					
PT-500, 700, 805, 815	BL11757-000	6' / Straight	DB-9M	8 Pin DIN	Auto-power (DTR)

Appendix B

Media Supplies

To insure maximum printer life and consistent print quality and performance for your individual application, it is recommended that only media produced by Zebra be used. Advantages include:

- Consistent quality and reliability of media products.
- Large range of stocked and standard formats.
- In-house custom format design service.
- Large production capacity which services the needs of many large and small media consumers including major retail chains world wide.
- Media products that meet or exceed industry standards.

For more information call Zebra Technologies Corporation at +1.866.230.9495 (U.S., Canada and Mexico) and ask to speak to a Media Sales Representative.

Appendix C

Maintenance Supplies

In addition to using quality media provided by Zebra, it is recommended that the printer be cleaned as prescribed in the maintenance section. The following items are available for this purpose:

- Cleaning Pen (10 pack), Reorder No. AN11209-1
- Cleaning Kit with Cleaning Pen, and Cotton Swabs, Reorder No. AT702-1

Appendix D

Product Support

When calling with a specific problem regarding your printer, please have the following information on hand:

- Model number/type (e.g. QL 420)
- Unit serial number
- Product Configuration Code (PCC)

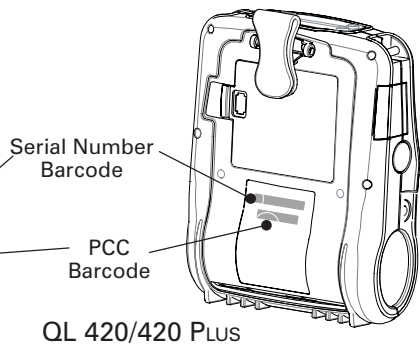
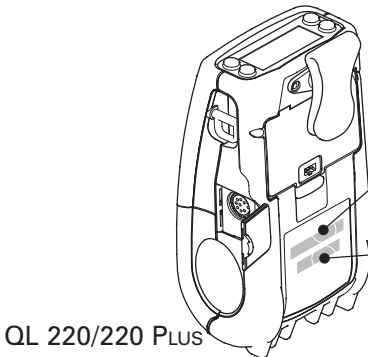
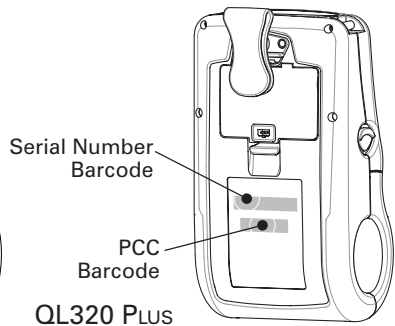
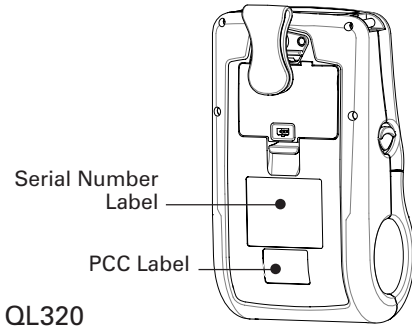

For product support, contact Zebra Technologies at:
www.zebra.com

Zebra Technologies International, LLC
333 Corporate Woods Parkway
Vernon Hills, Illinois 60061-3109 USA
Phone: +1.847.793.2600 or
+1.800.423.0422
Fax: +1.847.913.8766

Zebra Technologies Europe Limited
Zebra House
The Valley Centre, Gordon Road
High Wycombe
Buckinghamshire HP13 6EQ, UK
Phone: +44.1494.472872
Fax: +44.1494.450103

Zebra Technologies
Latin American Sales Office
9800 NW 41ST Street
Suite 220
Doral, Florida 33178 USA
Phone: +1.305.558.8470
Fax: +1.305.558.8485

Zebra Technologies Asia Pacific, LLC
1 Sims Lane, #06-11
Singapore 387355
Phone: +65-68580722
Fax: +65-68850838

Appendix D

Battery Disposal



The EPA certified RBRC® Battery Recycling Seal on the Lithium-Ion (Li-Ion) battery supplied with your printer indicates Zebra Technologies Corporation is voluntarily participating in an industry program to collect and recycle these batteries at the end of their useful life, when taken out of service in the United States or Canada. The RBRC® program provides a convenient alternative to placing used Li-Ion batteries into the trash or the municipal waste stream, which may be illegal in your area.

Please call 1-800-8-BATTERY for information on Li-Ion battery recycling and disposal bans/restrictions in your area. Zebra Technologies Corporation's involvement in this program is part of our commitment to preserving our environment and conserving our natural resources.

Outside North America, please follow local battery recycling guidelines.

Product Disposal



Do not dispose of this product in unsorted municipal waste. This product is recyclable. Please recycle according to your local standards. For more information, please see our web site at: <http://www.zebra.com/recycle>

Index

A

Accessories

- Belt clip 43
- Carrying Strap 46
- Desk Stand 44
- Kickstand 43
- list of 72
- Shoulder Strap 45
- using 43

B

- Battery, charging 12, 44
 - while printing 12
- Battery, installing 11
- Battery life, tips for extending 47
- Bluetooth Device Address (BDA) 32
- Bluetooth™ Networking Overview 32

C

- Charger, battery
 - LI 72 (single charger) 12
 - UCLI72-4 Quad Charger 13
 - charging times 13
 - front panel indicators 13

Cleaning

- general instructions 48
- Interior 49, 53
- Linerless platen roller 53
- media supports 49
- Sensors 49
- Tear bar 53
- Cleaning, QL 220
 - Exterior 49
 - Interior 49
 - linerless platen 49
 - Peel bar 49
 - Printhead 49
 - Tear bar 49

Cleaning, QL 320

- edge guides 51
- Exterior 51
- Interior 51
- linerless platen 51
- Peel bar 51
- Printhead 51
- Sensors 51
- Tear bar 51

Cleaning, QL 420

- edge guides 53
- Exterior 53
- linerless platen 53
- Linerless platen roller 53
- Peel bar 53
- Printhead 53
- Sensors 53

- Communications. *See also* Wireless communication
 - cable
 - strain relief for 28

- infrared (IR) 30
- RS232
 - Connector signals 67
 - with a cable 27
- USB

- Connector signals 67
- with a cable 27

- Communications diagnostics 57
- Configuration label, printing 57

D

- Damage, shipping 7
- Declaration of Conformity
 - EU countries
 - Bluetooth radio (ZBR3) 31
 - Compact Flash (CF) 802.11b 34
 - Frequency Hopping for QL 320 & 420 40
 - PCMCIA 802.11b for QL 420 38

L

- Label Vista 25, 41, 42
- use in troubleshooting 57

M

Manual

- CPCL Programming 7, 41, 42
- EPL Programming 42
- ZPL II Programming 42

Media, loading 16

- fan-fold media 19
 - media spacer, use of 19
- peel-off mode 20
- QL 320 Printers 17
- QL 420 and QL 220 Printers 16
- tear-off mode 20

O

- Operator Controls 21
 - LCD Keypad 23
 - functions displayed 25
 - Standard Keypad 21
 - error indicator 22
 - power-on indicator 21

P

Platen

- linerless 53

Programming language

- CPCL 7
- EPL 42
- ZPL II 42
 - interpreter for 7

Q

- QuickLink™ module 21, 22

R

- Regulatory Information
 - Bluetooth radio (ZBR3) 31
 - CF WLAN radio 33

PCMCIA WLAN radio for QL 320 &
420

frequency hopping 39

PCMCIA WLAN radio, QL 320 35

PCMCIA WLAN radio, QL 420 37

S

Safety Precautions

placement of charger 15

while charging battery 14

Software 42

Specifications

Font/bar Code 66

Label 65

Memory/communications 64

Physical 68

printing 64

T

Technical Support, contacting 58

Troubleshooting

entering Communications Diagnostics Mode 57

entering Communications Diagnostics Mode Diagnostics 57

LCD Control Panel 54

Standard control panel indicators 54

Troubleshooting tests 57

printing a configuration label 26, 57

configuration label example 58

configuration label example (QL plus) 60

Troubleshooting Topics 55

W

Wireless communication

Bluetooth™ (ZBR3 radio) 31

Infrared (IrDA) 30

Local Area Network 21

Local Area Network (PCMCIA radio) using PCMCIA Rad

Frequency Hopping for QL 320 & 420 PCMCIA radio 39

QL 420 PCMCIA radio 37

Local Area Network using CF Radio 33

Local Area Network using PCMCIA Radio

QL 320 35

Patent Numbers

This product and/or its use may be covered by one or more of the following US patents and corresponding international patents worldwide

D275,286	5,029,183	5,364,133	5,543,610	6,034,708
D347,021	5,047,617	5,367,151	5,545,889	6,036,383
D389,178	5,103,461	5,372,439	5,552,592	6,057,870
D430,199	5,113,445	5,373,148	5,570,123	6,068,415
D433,702	5,140,144	5,378,882	5,578,810	6,070,805
3,964,673	5,132,709	5,396,053	5,589,680	6,095,704
4,019,676	5,142,550	5,396,055	5,612,531	6,109,801
4,044,946	5,149,950	5,399,846	5,642,666	6,123,471
4,360,798	5,157,687	5,408,081	5,657,066	6,147,767
4,369,361	5,168,148	5,410,139	5,768,991	6,151,037
4,387,297	5,168,149	5,410,140	5,790,162	6,201,255 B1
4,460,120	5,180,904	5,412,198	5,791,796	6,231,253 B1
4,496,831	5,229,591	5,415,482	5,806,993	6,261,009
4,593,186	5,230,088	5,418,812	5,813,343	6,261,013
4,607,156	5,235,167	5,420,411	5,816,718	6,267,521
4,673,805	5,243,655	5,436,440	5,820,279	6,270,072 B1
4,736,095	5,247,162	5,444,231	5,848,848	6,285,845 B1
4,758,717	5,250,791	5,449,891	5,860,753	6,292,595
4,816,660	5,250,792	5,449,893	5,872,585	6,296,032
4,845,350	5,262,627	5,468,949	5,874,980	6,364,550
4,896,026	5,267,800	5,479,000	5,909,233	6,379,058 B1
4,897,532	5,280,163	5,479,002	5,976,720	6,409,401 B1
4,923,281	5,280,164	5,479,441	5,978,004	6,411,397 B1
4,933,538	5,280,498	5,486,057	5,995,128	6,428,227 B2
4,992,717	5,304,786	5,503,483	5,997,193	6,530,705
5,015,833	5,304,788	5,504,322	6,004,053	6,540,122
5,017,765	5,321,246	5,528,621	6,010,257	6,607,316
5,021,641	5,335,170	5,532,469	6,020,906	6,609,844



www.zebra.com

Zebra Technologies International, LLC

333 Corporate Woods Parkway
Vernon Hills, Illinois 60061.3109 USA

Phone: +1.847.634.6700

Toll-Free: +1.800.423.0422

Fax: +1.847.913.8766

Free Manuals Download Website

<http://myh66.com>

<http://usermanuals.us>

<http://www.somanuals.com>

<http://www.4manuals.cc>

<http://www.manual-lib.com>

<http://www.404manual.com>

<http://www.luxmanual.com>

<http://aubethermostatmanual.com>

Golf course search by state

<http://golfingnear.com>

Email search by domain

<http://emailbydomain.com>

Auto manuals search

<http://auto.somanuals.com>

TV manuals search

<http://tv.somanuals.com>