

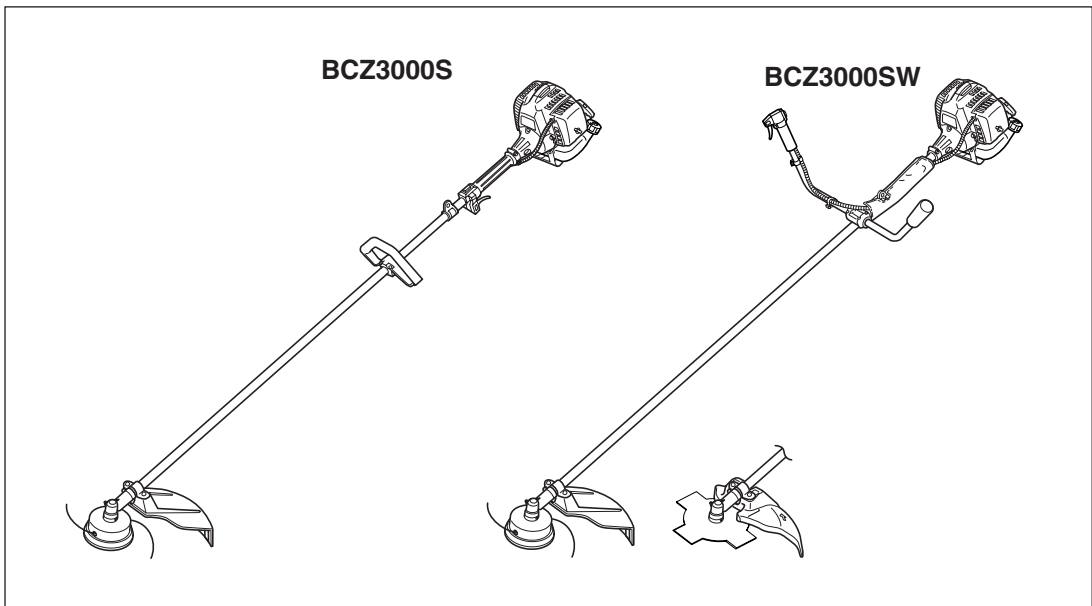

OWNER/OPERATOR MANUAL

BRUSHCUTTERS

BCZ3000S
BCZ3000SW



WARNING



The engine exhaust from this product contains chemicals known to the State of California to cause cancer, birth defects or other reproductive harm.



WARNING



Before using our brushcutters, please read this manual carefully to understand the proper use of your unit.

APPLICABLE SERIAL NUMBERS :

DRIVE UNIT 300001 and up

ENGINE UNIT 300001 and up



SAFETY FIRST

Instructions contained in warnings within this manual marked with a  symbol concern critical points which must be taken into consideration to prevent possible serious bodily injury, and for this reason you are requested to read all such instructions carefully and follow them without fail.

■ WARNINGS IN THE MANUAL



This mark indicates instructions which must be followed in order to prevent accidents which could lead to serious bodily injury or death.



This mark indicates instructions which must be followed, or it leads to mechanical failure, breakdown, or damage.



This mark indicates hints or directions useful in the use of the product.

CONTENTS

1. Parts location	4
2. Specifications	4
3. Warning labels on the machine	5
4. Symbols on the machine	6
5. For safe operation	7
6. Set up	13
7. Fuel	16
8. Operation	18
9. Maintenance	21
10. Storage	24
11. Optional blade usage	25
12. Troubleshooting guide	30
13. Parts list	31

1. Parts location

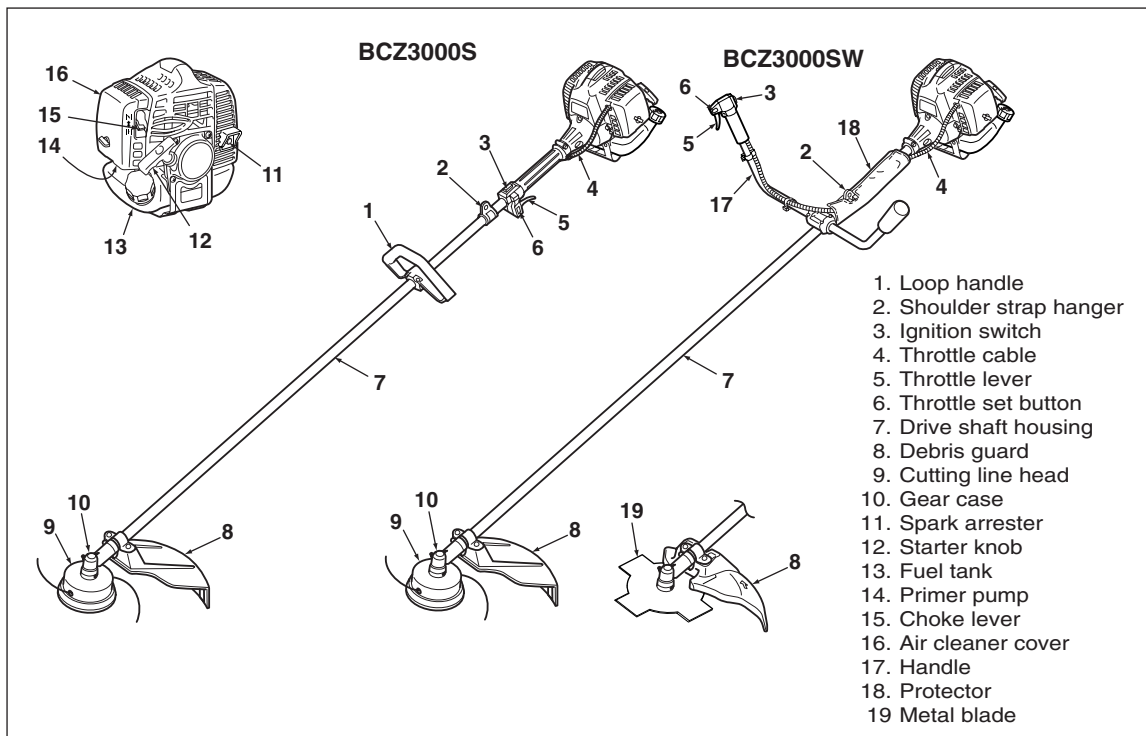

2. Specifications

■ BCZ3000S/BCZ3000SW

Overall size(LxWxH)

BCZ3000S..... 72.5(1843)x9.4(240)x12.87(327) in(mm)

BCZ3000SW 72.5(1843)x24.3(618)x16.38(416) in(mm)

Dry weight w/o acc.

BCZ3000S 12.1 lbs (5.49kg) (12.94 lbs (5.87kg)Including tap head)

BCZ3000SW 12.65 lbs (5.74kg) (13.49 lbs (6.12kg)Including tap head)

Engine Type..... Air-cooled 2-stroke gasoline

Model..... Zenoah GZ30N

Displacement 1.8cu-in (29.5cm³)

Max. output 1.4Hp (1.0kW)at 8500/min⁻¹(rpm)

Idle speed.....3000±200/min⁻¹(rpm)

Fuel Mixture(Gasoline 50 : Oil 1)

Carburetor Walbro Diaphragm type

Spark plugCHAMPION RZ7C

Fuel tank capacity.....24.3 fl.oz (0.72ℓ)

Transmission..... Centrifugal clutch, Rigid driveshaft

Reduction ratio 1.462

Cutting head rotating direction Counter-clockwise(Operator view)

Durability period.....EXTENDED

Standard Accessories

4 in. 2-line Head 1 pc.

Shoulder Strap 1 pc.

Goggle..... 1 pc.

Tool Kit 1 pc.

Specifications are subject to change without notice.

3. Warning labels on the machine

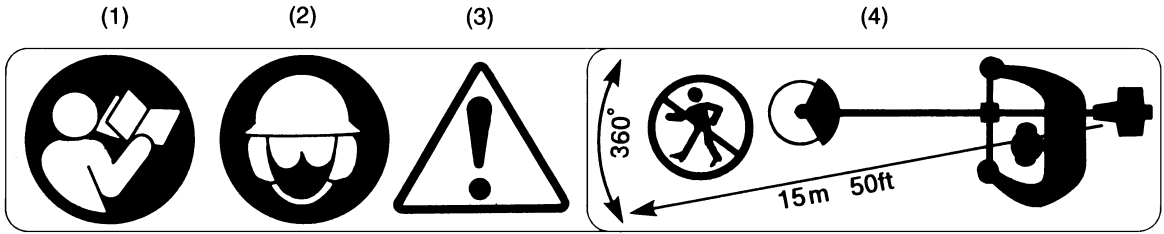

- (1) Read owner's manual before operating this machine.
- (2) Wear head, eye and ear protection.
- (3) Warning/Attention
- (4) Keep all children, bystanders and helpers 15 meters away from the brushcutter

! IMPORTANT

If warning label peel off or become soiled and impossible to read, you should contact the dealer from which you purchased the product to order new labels and affix them in the required location(s).

! WARNING

Never modify your brushcutter.

We won't warrant the machine, if you use the remodeled brushcutter or you don't observe the proper usage written in the manual.

4. Symbols on the machine



(a)

For safe operation and maintenance, symbols are carved in relief on the machine. According to these indications, please be careful not to take a mistake.

(a) The port to refuel the "MIX GASOLINE"

Position: FUEL TANK CAP



(b)

(b) The direction to close the choke

Position: AIR CLEANER COVER



(c)

(c) The direction to open the choke

Position: AIR CLEANER COVER

IMPORTANT ENGINE INFORMATION

THIS ENGINE MEETS U.S. EPA PH2 AND 2003 CALIFORNIA EMISSION REGULATIONS FOR SI

SORE'S COMPLIANCE PERIOD : CATEGORY A

ENGINE FAMILY : 3KZXS. 0294NO ; EM

ENGINE DISPLACEMENT : 29.5cc

REFER TO OWNER'S MANUAL FOR MAINTENANCE SPECIFICATIONS AND ADJUSTMENTS.

MANUFACTURED : Aug. 2003

KOMATSU ZENOAH CO. MADE IN JAPAN



Use RedMax 50:1 Oil !

INFORMATION IMPORTANTE CONCERNANT LE MOTEUR

Ce moteur est conforme aux normes U.S. EPA PH2 et 2003 ainsi qu'aux autres dispositions ultérieures de la réglementation concernant la pollution de l'air pour les petits moteurs tout-terrain avec une période de accordable : CATEGORY A

Type de moteur : 3KZXS. 0294NO : EM

Cylindrée du moteur : 29,5cc

Se référer au Manuel de l'utilisateur pour les spécifications d'entretien et les réglages.

Manufacturé : Août 2003

KOMATSU ZENOAH CO. MADE IN JAPAN



Use RedMax 50:1 Oil !

5. For safe operation

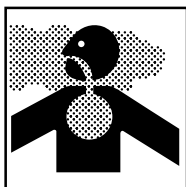
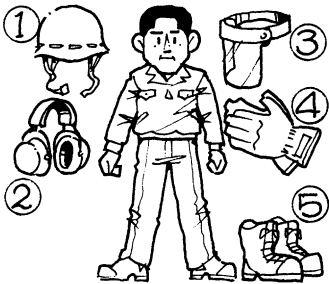
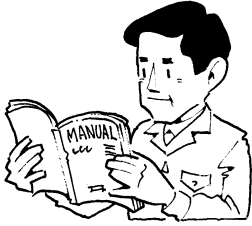

1. Read this manual carefully until you completely understand and follow all safety and operating instructions.
2. Keep this manual handy so that you may refer to it later whenever any questions arise. Also note, if you have any questions which cannot be answered herein, contact the dealer from whom you purchased the product.
3. Always be sure to include this manual when selling, lending, or otherwise transferring the ownership of this product.
4. Never allow children or anyone unable to fully understand the directions given in the manual to use the machine.

■ WORKING CONDITION

1. When using the product, you should wear proper clothing and protective equipment.

(1) Helmet

(2) Ear protectors

(3) Protection goggles or face protector

(4) Thick work gloves

(5) Non-slip-sole work boots

2. And you should carry with you.

- (1) Attached tools and files
- (2) Properly reserved fuel
- (3) Spare blade
- (4) Things to notify your working area (rope, warning signs)
- (5) Whistle (for collaboration or emergency)
- (6) Hatchet or saw (for removal of obstacles)

3. Do not wear loose clothing, jewelry, short trousers, sandals, or go barefoot. Do not wear anything which might be caught by a moving part of the unit. Secure hair so it is above shoulder length.

■ WORKING CIRCUMSTANCE

1. Never start the engine inside a closed room or building. Exhaust gases contain dangerous carbon monoxide.
2. Never use the product,
 - a. when the ground is slippery or when you can't maintain a steady posture.

5. For safe operation

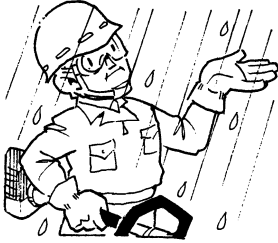

- b. At night, at times of heavy fog, or at any other times when your field of vision might be limited and it would be difficult to gain a clear view of the working area.
- c. During rain storms, during lightning storms, at times of strong or gale-force winds, or at any other times when weather conditions might make it unsafe to use the product.



■ WORKING PLAN

1. You should never use the product when under the influence of alcohol, when suffering from exhaustion or lack of sleep, when suffering from drowsiness as a result of having taken cold medicine or at any other time when a possibility exists that your judgment might be impaired or that you might not be able to operate the product properly and in a safe manner.
2. When planning your work schedule, allow plenty of time to rest. Limit the amount of time over which the product is to be used continuously to somewhere around 30~40 minutes per session, and take 10~20 minutes of rest between work sessions. Also try to keep the total amount of work performed in a single day under 2 hours or less.



WARNING

1. If you don't observe the working time, or working manner (See ■USING THE PRODUCT), Repetitive Stress Injury(RSI) could occur.
If you feel discomfort, redness and swelling of your fingers or any other part of your body, see a doctor before getting worse.
2. To avoid noise complaints, in general, operate product between 8a.m. and 5p.m. on weekdays and 9a.m. to 5p.m. weekends.



NOTE

Check and follow the local regulations as to sound level and hours of operations for the product.



5. For safe operation

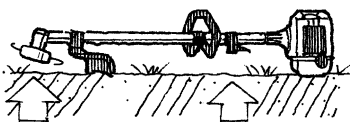
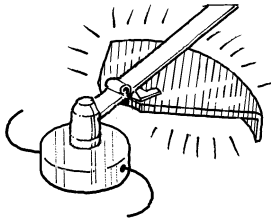
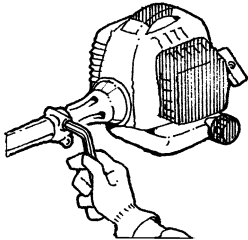
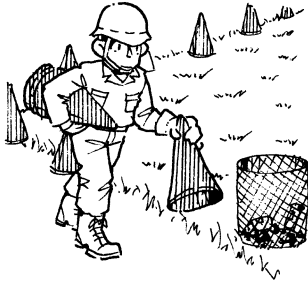

■ BEFORE STARTING THE ENGINE

1. The area within a perimeter of 50 feet (15m) of the person using the product should be considered a hazardous area into which no one should enter. If necessary yellow warning rope, warning signs should be placed around the perimeter of the area. When work is to be performed simultaneously by two or more persons, care should also be taken to constantly look around or otherwise check for the presence and locations of other people working so as to maintain a distance between each person sufficient to ensure safety.
2. Check the condition of working area to avoid any accident by hitting hidden obstacles such as stumps, stones, cans, or broken grass.

! IMPORTANT

Remove any obstacle before beginning work.

3. Inspect the entire unit for loose fasteners and fuel leakage. Make sure that the cutting attachment is properly installed and securely fastened.
4. Use the guard which is suitable for the cutting head. If the cutting head is the metal blade, change the guard. In case of BCZ3000S, handle also need to be changed.
5. Always use the shoulder strap. Adjust the strap before starting the engine at the position that your left hand can comfortably hold the handlebar grip approximately waist high.

■ STARTING THE ENGINE

1. Keep bystanders and animals at least 50feet (15m) away from the operating point. If you are approached, immediately stop the engine.
2. The product is equipped with a centrifugal clutch mechanism, so the cutting attachment begins to rotate as soon as the engine is started by putting the throttle into the start position. When starting the engine, place the product onto the ground in a flat clear area and hold it firmly in place so as to ensure that neither the cutting part nor the throttle come into contact with any obstacle when the engine starts.

5. For safe operation

WARNING

Never place the throttle into the high speed position when starting the engine.

3. After starting the engine, check to make sure that the cutting attachment stops rotating when the throttle is moved fully back to its original position. If it continues to rotate even after the throttle has been moved fully back, turn off the engine and take the unit to your authorized Red Max servicing dealer for repair.

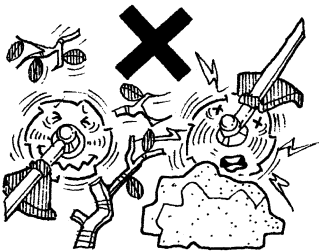

■ USING THE PRODUCT

IMPORTANT

Cut only materials recommended by the manufacturer. And use only for tasks explained in the manual.



1. Grip the handles firmly with both hands using your whole hand. Place your feet slightly apart (slightly further apart than the width of your shoulders) so that your weight is distributed evenly across both legs, and always be sure to maintain a steady, even posture while working.
2. Keep cutting attachment below waist level.
3. Maintain the speed of the engine at the level required to perform cutting work, and never raise the speed of the engine above the level necessary.
4. If the unit start to shake or vibrate, turn off the engine and check the whole unit. Do not use it until the trouble has been properly corrected.
5. Keep all parts of your body away from rotating cutting attachment and hot surfaces.
6. Never touch the muffler, spark plug, or other metallic parts of the engine while the engine is in operation or immediately after shutting down the engine. Doing so could result in serious burns or electrical shock.



5. For safe operation

• IF SOMEONE COMES

1. Guard against hazardous situations at all times. Warn adults to keep pets and children away from the area. Be careful if you are approached. Injury may result from flying debris.
2. If someone calls out or otherwise interrupts you while working, always be sure to turn off the engine before turning around.



■ MAINTENANCE

1. In order to maintain your product in proper working order, perform the maintenance and checking operations described in the manual at regular intervals.
2. Always be sure to turn off the engine before performing any maintenance or checking procedures.



WARNING

The metallic parts reach high temperatures immediately after stopping the engine.

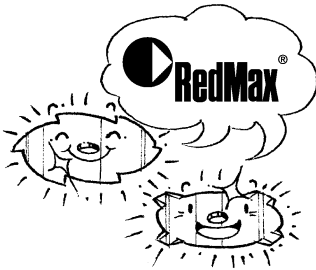

3. When replacing the cutting attachment or any other part, or when replacing the oil or any lubricant, always be sure to **use only RedMax products or products which have been certified by RedMax for use with the RedMax product.**
4. In the event that any part must be replaced or any maintenance or repair work not described in this manual must be performed, please contact a representative from the store nearest RedMax authorized servicing dealer for assistance.
5. Do not use any accessory or attachment other than those bearing the RedMax mark and recommended for the unit.
6. Under no circumstances should you ever take apart the product or alter it in any way. Doing so might result in the product becoming damaged during operation or the product becoming unable to operate properly.

■ HANDLING FUEL

1. The engine of the RedMax product is designed to run on a mixed fuel which contains highly flammable gasoline. Never store cans of fuel or

5. For safe operation

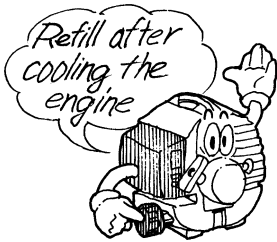

refill the tank of the unit in any place where there is a boiler, stove, wood fire, electrical sparks, welding sparks, or any other source of heat or fire which might ignite the fuel.

2. Never smoke while operating the unit or refilling its fuel tank.
3. When refilling the tank, always turn off the engine and allow it to cool down. Take a careful look around to make sure that there are no sparks or open flames anywhere nearby before refueling.
4. Wipe spilled fuel completely using a dry rag if any fuel spillage occurs during refueling.
5. After refueling, screw the fuel cap back tightly onto the fuel tank and then carry the unit to a spot 10feet (3m) or more away from where it was refueled before turning on the engine.

■ TRANSPORTATION

1. When hand-carrying the product, cover over the cutting part if necessary, lift up the product and carry it paying attention to the blade.
2. Never transport the product over rough roads over long distances by vehicle without removing all fuel from the fuel tank. If doing so, fuel might leak from the tank during transport.

6. Set up (BCZ3000S)

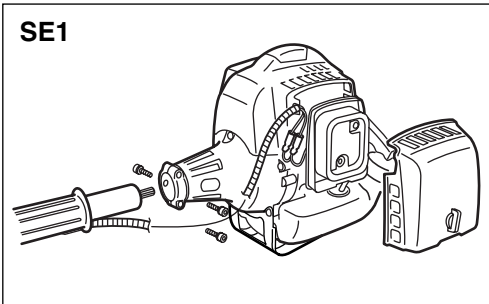

■ MOUNTING ENGINE (SE1)

1. Push the driveshaft housing toward the clutch housing and rotate it by hand to check that the driveshaft is engaged with the gears.
2. Insert the driveshaft housing into the clutch housing until it bottoms, and align the positioning holes on the clutch housing and the shaft tube and install the screw. When difficult to engage, twist the engine slightly.
3. Fasten the clamp securely with two screws.

⚠ IMPORTANT

Tighten the screws gradually by turns.

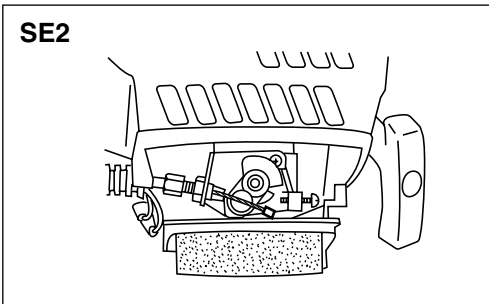

■ CONNECTING THROTTLE WIRE

1. Remove the air cleaner cover.
2. Connect the end of the throttle wire to the joint on the top of the carburetor. (SE2)

■ CONNECTING SWITCH WIRES

- Connect the switch wires between the engine and the main unit. Pair the wires of the same color.

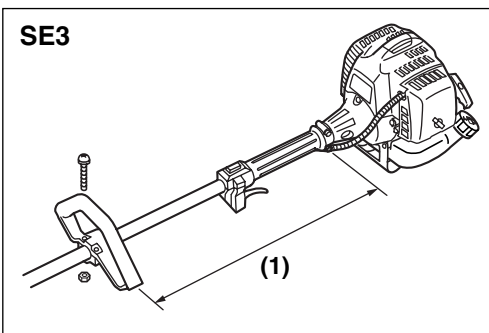

■ INSTALLING HANDLE

- Mount the handle to the shaft tube and clamp it at a location that is comfortable to you. (SE3)

(1) About 19 inches (48cm)

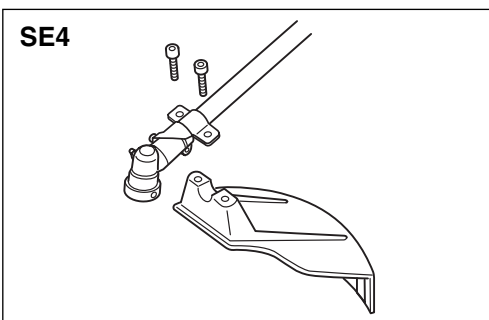

■ INSTALLING DEBRIS GUARD

- Put the debris guard on the bracket, attach it with the 2 screws. (SE4)

6. Set up (BCZ3000SW)

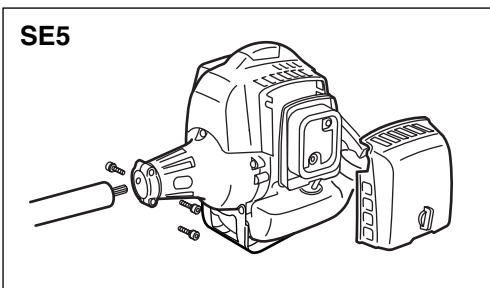

■ MOUNTING ENGINE (SE5)

1. Push the driveshaft housing toward the clutch housing and rotate it by hand to check that the driveshaft is engaged with the gears.
2. Insert the driveshaft housing into the clutch housing until it bottoms, and align the positioning holes on the clutch housing and the shaft tube and install the screw. When difficult to engage, twist the engine slightly.
3. Fasten the clamp securely with two screws.

⚠ IMPORTANT

Tighten the screws gradually by turns.

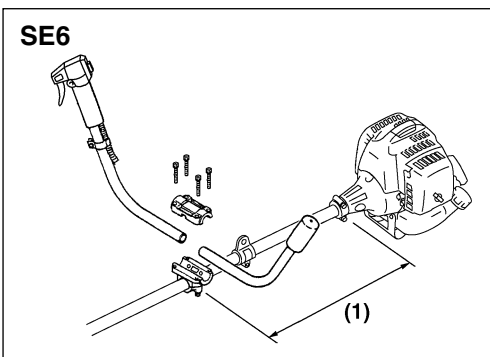

■ INSTALLING HANDLE

- Mount the handle to the shaft tube and clamp it at a location that is comfortable to you. (SE6)

(1) About 14.5 inches (37cm)

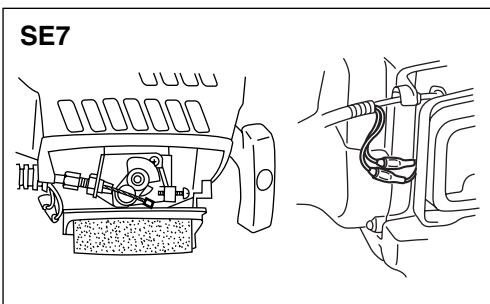

■ CONNECTING THROTTLE WIRE

1. Remove the air cleaner cover.
2. Connect the end of the throttle wire to the joint on the top of the carburetor. (SE7)

■ CONNECTING SWITCH WIRES

1. Connect the switch wires between the engine and the main unit. Pair the wires of the same color. (SE7)
2. Insert the terminal in the clamp.

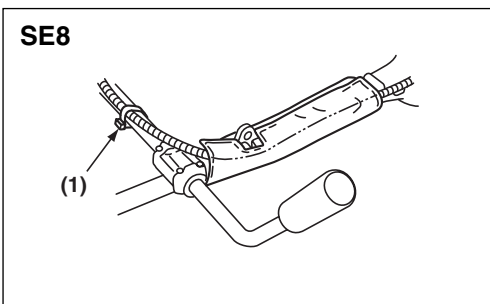

■ PUTTING ON WAIST PAD

- Fix the tube by the band. (SE8)

(1) Band

6. Set up (BCZ3000S/BCZ3000SW)

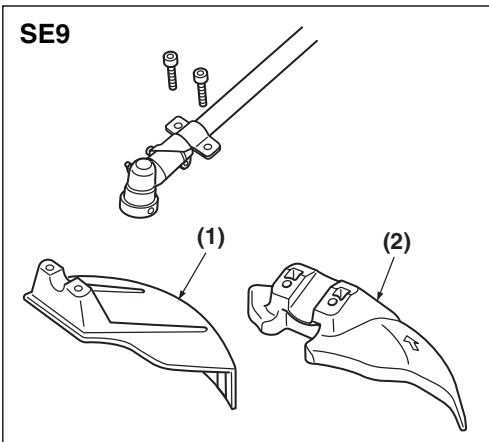

■ INSTALLING DEBRIS GUARD

- Put the debris guard on the gear box, attach it with the 2 screws. (SE9)

⚠ IMPORTANT

2 kinds of debris guard are packed in with BC3000SW. Choose the guard suitable for a cutting head. If the right guard is not used, it may lead to a serious accident. (SE9)

(1) Guard for Line Head (Red)

(848-JC0-6610)

(2) Guard for Blade (Black)

(T3246-24110)

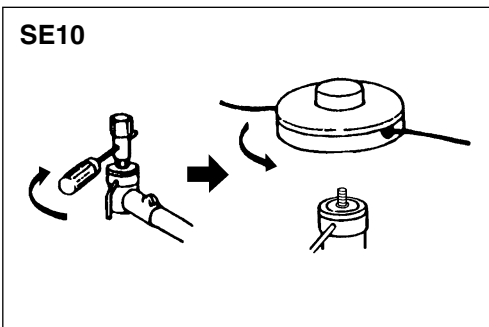

■ INSTALLING CUTTING HEAD (SE10)

1. While locking the gear shaft, by inserting the supplied tool into the upper holder on the gear box, loosen and remove the hexagon nut(left-handed)
2. Fit the holder attached to the upper holder. Then screw in the cutting head to the gear shaft over the holders. Hand-tighten it securely.

⚠ IMPORTANT

You need not holder (B) and nut when installing the cutting head.



■ BALANCE UNIT

1. Put on strap and attach unit to strap.
2. Slide clamp up or down until unit balances with head just touching on the ground. (SE11)

7. Fuel

⚠ WARNING

- Gasoline is very flammable. Avoid smoking or bringing any flame or sparks near fuel. Make sure to stop the engine and allow it cool before refueling the unit. Select outdoor bare ground for fueling and move at least 3m (10ft) away from the fueling point before starting the engine.



- The RedMax engines are lubricated by oil specially formulated for air-cooled 2-cycle gasoline engine use. If RedMax oil is not available, use an anti-oxidant added quality oil expressly labeled for air-cooled 2-cycle engine use. (JASO FC GRADE OIL or ISO EGC GRADE)
- Do not use BIA or TCW (2-stroke water-cooling type) mixed oil.

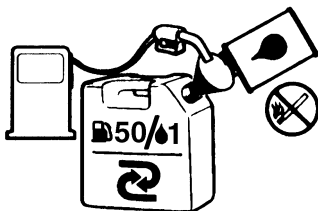

■ RECOMMENDED MIXING RATIO GASOLINE 50:OIL 1

50:1 MIXING CHART

GASOLINE gal.	1	2	3	4	5
2-CYCLE OIL fl.oz	2.6	5.2	7.8	10.4	13

GASOLINE liter	1	2	3	4	5
2-CYCLE OIL ml	20	40	60	80	100

- Exhaust emission are controlled by the fundamental engine parameters and components (eq., carburation, ignition timing and port timing) without addition of any major hardware or the introduction of an inert material during combustion.
- These engines are certified to operate on unleaded gasoline.
- Make sure to use gasoline with a minimum octane number of 89 RON (USA/Canada: 87AL)
- If you use a gasoline of a lower octane value than prescribed, there is a danger that the engine temperature may rise and an engine problem such as piston seizing may consequently occur.
- Unleaded gasoline is recommended to reduce the contamination of the air for the sake of your health and the environment.
- Poor quality gasolines or oils may damage sealing rings, fuel lines or fuel tank of the engine.

■ HOW TO MIX FUEL

⚠ IMPORTANT

Pay attention to agitation.

- Measure out the quantities of gasoline and oil to be mixed.
- Put some of the gasoline into a clean, approved fuel container.
- Pour in all of the oil and agitate well.
- Pour In the rest of gasoline and agitate

7. Fuel

again for at least one minute. As some oils may be difficult to agitate depending on oil ingredients, sufficient agitation is necessary for the engine to last long. Be careful that, if the agitation is insufficient, there is an increased danger of early piston seizing due to abnormally lean mixture.

5. Put a clear indication on the outside of the container to avoid mixing up with gasoline or other containers.
6. Indicate the contents on outside of container for easy identification.

■ FUELING THE UNIT

1. Untwist and remove the fuel cap. Rest the cap on a dustless place.
2. Put fuel into the fuel tank to 80% of the full capacity.
3. Fasten the fuel cap securely and wipe up any fuel spillage around the unit.

WARNING

1. Select bare ground for fueling.
2. Move at least 10feet (3meters) away from the fueling point before starting the engine.
3. Stop the engine before refueling the unit. At that time, be sure to sufficiently agitate the mixed gasoline in the container.

FOR YOUR ENGINE LIFE, AVOID;

1. FUEL WITH NO OIL(RAW GASOLINE) – It will cause severe damage to the internal engine parts very quickly.
2. GASOHOL – It can cause deterioration of rubber and/or plastic parts and disruption of engine lubrication.
3. OIL FOR 4-CYCLE ENGINE USE – It can cause spark plug fouling, exhaust port blocking, or piston ring sticking.
4. **Mixed fuels which have been left unused for a period of one month or more** may clog the carburetor and result in the engine failing to operate properly.
5. In the case of storing the product for a

long period of time, clean the fuel tank after rendering it empty. Next, activate the engine and empty the carburetor of the composite fuel.

6. In the case of scrapping the used mixed oil container, scrap it only at an authorized repository site.

NOTE

As lot details of quality assurance, read the description in the section Limited Warranty carefully. Moreover, normal wear and change in product with no functional influence are not covered by the warranty. Also, be careful that, if the usage in the instruction manual is not observed as to the mixed gasoline, etc. described therein, it may not be covered by the warranty.

8. Operation

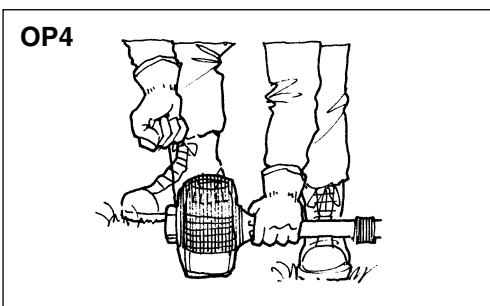
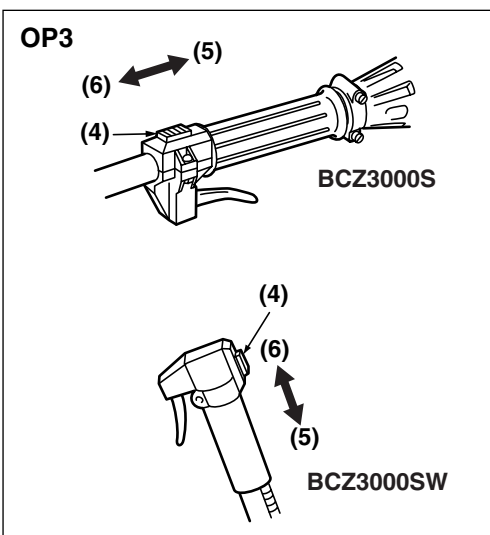
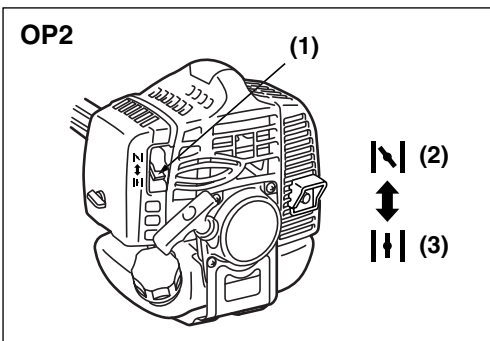
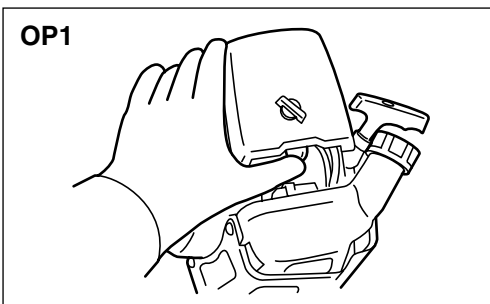

■ STARTING ENGINE

⚠ WARNING

The cutting head will start rotating upon the engine starts.

1. Rest the unit on a flat, firm place. Keep the cutting head off the ground and clear of surrounding objects as it will start rotating upon starting of the engine.
2. Push the primer pump several times until overflow fuel flows out in the clear tube. (OP1)
3. Move the choke lever to the closed position. (OP2)
4. Set the ignition switch to the "start" position. (OP3)
5. While holding the unit firmly, pull out the starter rope quickly until engine fires. (OP4)

(1) choke lever (2) close (3) open
(4) ignition switch (5) start (6) stop

⚠ IMPORTANT

- Avoid pulling the rope to its end or returning it by releasing the knob. Such actions can cause starter failures.
6. Move the choke lever downward to open the choke. And restart engine. (OP2)
 7. Allow the engine to warm up for a several minutes before starting operation.

📖 NOTE

1. When restarting the engine immediately after stopping it, leave the choke open.
2. Overchoking can make the engine hard to start due to excess fuel. When the engine failed to start after several attempts, open the choke and repeat pulling the rope, or remove the spark plug and dry it.

8. Operation

■ STOPPING ENGINE (OP3)

1. Release the throttle lever and run the engine for a half minute.
2. Shift the ignition switch to the STOP position.

⚠ IMPORTANT

- Except for an emergency, avoid stopping the engine while pulling the throttle lever.

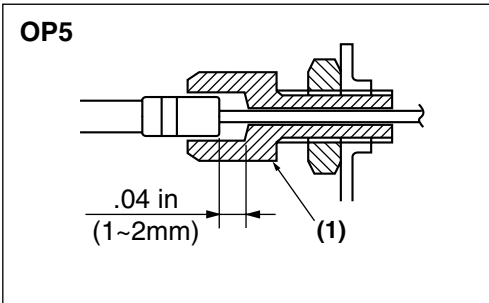

■ ADJUSTING THROTTLE CABLE

- The normal play is 1 or 2mm when measured at the carburetor side end. Readjust with the cable adjuster as required. (OP5)

(1) cable adjuster

■ ADJUSTING IDLING SPEED (OP6)

1. When the engine tends stop frequently at idling mode, turn the adjusting screw clockwise.
2. When the cutting head keeps rotating after releasing the trigger, turn the adjusting screw counter-clockwise.

(1) idle adjusting screw

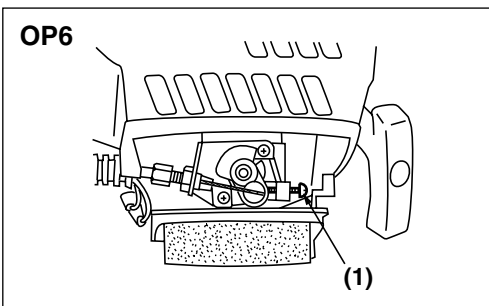

📖 NOTE

- Warm up the engine before adjusting the idling speed.

■ CUTTING WORK (LINE HEAD USAGE)

⚠ WARNING

1. Always wear eye protection such as safety goggles. Never lean over the rotating cutting head. Rocks or other debris could be thrown into eyes and face and cause serious personal injury.
2. Keep the debris guard in place at all times when the unit is operated.

TRIMMING GRASS AND WEEDS

- Always remember that the TIP of the line does cutting. You will achieve better results by not crowding the line into the cutting area. Allow the unit to trim at its own pace.

8. Operation

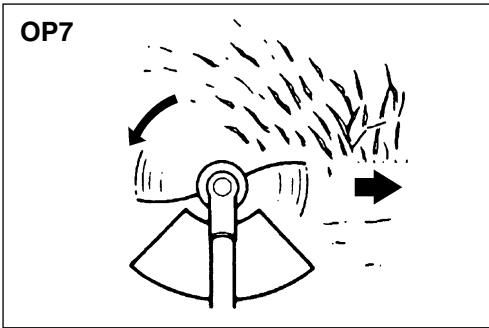

1. Hold the unit so the head is off the ground and is tilted about 20 degrees toward the sweep direction. (OP7)
2. You can avoid thrown debris by sweeping from your left to the right.
3. Use a slow, deliberate action to cut heavy growth. The rate of cutting motion will depend on the material being cut. Heavy growth will require slower action than will light growth.
4. Never swing the unit so hard as you are in danger of losing your balance or control of the unit.
5. Try to control the cutting motion with the hip rather than placing the full workload on the arm and hands.
6. Take precautions to avoid wire, grass and dead, dry, long-stem weeds from wrapping around the head shaft. Such materials can stall the head and cause the clutch to slip, resulting in damage to the clutch system if repeated frequently.

ADJUSTING THE LINE LENGTH

- Your brushcutters is equipped with a semi- auto type nylon line head that allows the operator to advance the line without stopping the engine. When the line becomes short, lightly tap the head on the ground while running the engine at full throttle.
- Each time the head is bumped, the line advance about 1 inch(25.4 mm). For better effect, tap the head on bear ground or hard soil. Avoid bumping in thick, tall grass as the engine may stall by overload.

9. Maintenance

■ MAINTENANCE CHART

	system/component	procedure	before use	every 25 hours after	every 50 hours after	every 100 hours after	note
E N G I N E	fuel leaks, fuel spillage	wipe out	✓				
	fuel tank, air filter, fuel filter	inspect/clean	✓	✓			replace, if necessary
	idle adjusting screw	see ■ADJUSTING IDLING SPEED (p.19)	✓				replace carburetor if necessary
	spark plug	clean and readjust plug gap			✓		GAP: .025in(0.6~0.7mm) replace, if necessary
	cylinder fins, intake air cooling vent	clean		✓			
	muffler, spark arrester, cylinder exhaust port	clean				✓	
S H A F T	throttle lever, ignition switch	check operation	✓				
	cutting parts	replace if something's wrong	✓				
	debris guard	make sure to attach	✓				
	gear case	grease		✓			
	screws/nuts/bolts	tighten/replace	✓			✓	not adjusting screws

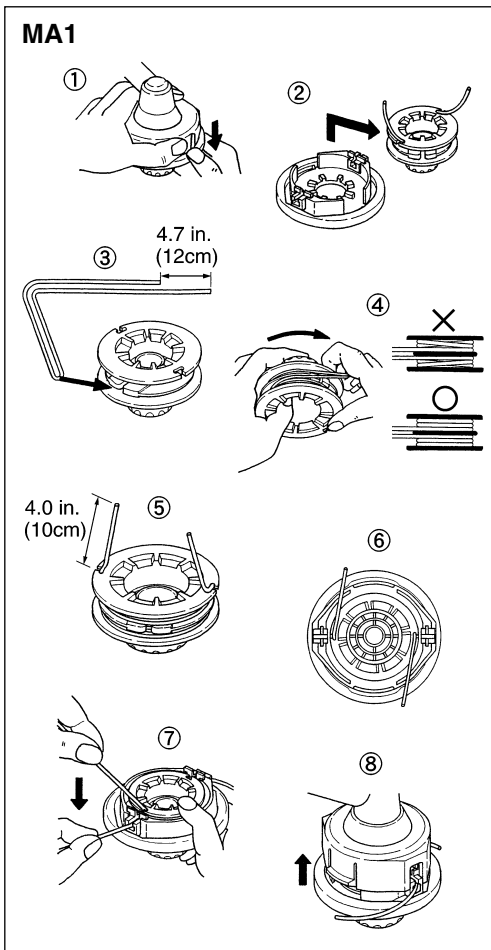

■ REFILLING TRIMMING LINE (MA1)

1. For replacement line, use a diameter of .095in (2.4mm). The spool is capable for a line upto 20ft (6m) on the 4" head. Avoid using a larger line as it may cut down the trimming performance.

⚠ WARNING

For safety reasons, do not use metalreinforced line.

2. Pinch the slotted area on the both sides of the spool housing to unhook the bottom cap.
3. Take out the spool and pull off the old line. Put one end of new line through the spool holes and pull it until the length is equal between each part of the line.
4. Wind up the line in the correct direction as indicated on the spool.
5. Hook each end of the line in the slot on the edge of the spool, and then put the ends through the eyelets on the housing. Make sure that the spring and the washers are in place.
6. While holding the spool against the housing, pull the line ends to release them from the slot.
7. Line up the slot on the bottom cap with the hook on the housing, press the cap against the housing until it clicks.

9. Maintenance

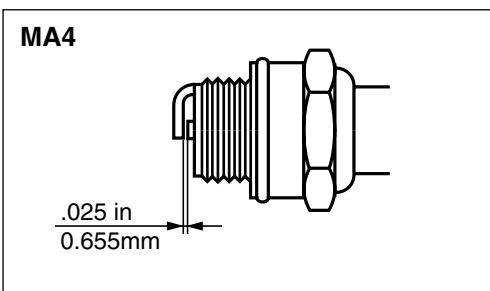
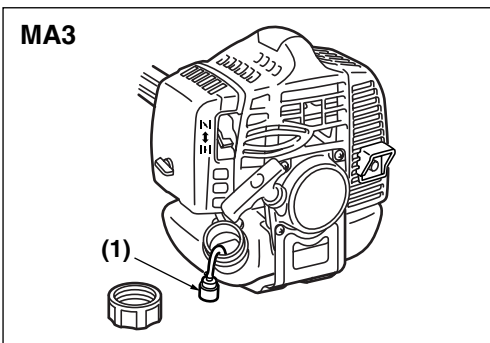
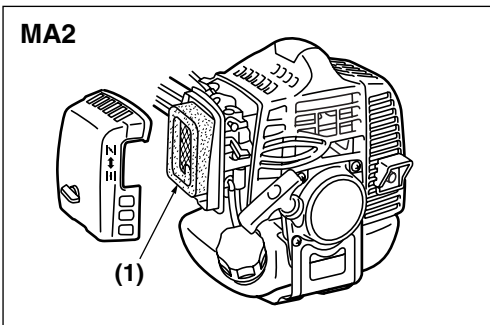

⚠ WARNING

- Make sure that the engine has stopped and is cool before performing any service to the machine. Contact with moving cutting head or hot muffler may result in a personal injury.

■ AIR FILTER

- The air filter, if clogged, will reduce the engine performance. Check and clean the filter element in warm, soapy water as required. Dry completely before installing. If the element is broken or shrunk, replace with a new one. (MA2)

(1) air filter

■ FUEL FILTER

- When the engine runs short of fuel supply, check the fuel cap and the fuel filter for blockage. (MA3)

(1) fuel filter

■ SPARK PLUG

- Starting failure and mis-firing are often caused by a fouled spark plug. Clean the spark plug and check that the plug gap is in the correct range. For a replacement plug, use the correct type specified by RedMax. (MA4)

- **REPLACEMENT PLUG IS A CHAMPION RZ7C.**

ⓘ IMPORTANT

- Note that using any spark plug other than those designated may result in the engine failing to operate properly or in the engine becoming overheated and damaged.
- To install the spark plug, first turn the plug until it is finger tight, then tighten it a quarter turn more with a socket wrench.

TIGHTENING TORQUE: 87~104 in-lbs
(9.8~11.8 N.m.)

9. Maintenance

■ MUFFLER

▲ WARNING

- Inspect periodically, the muffler for loose fasteners, any damage or corrosion. If any sign of exhaust leakage is found, stop using the machine and have it repaired immediately.
- **Note that failing to do so may result in the engine catching on fire.**

■ SPARK ARRESTER

- The muffler is equipped with a spark arrester to prevent red hot carbon from flying out of the exhaust outlet. Periodically inspect and clean as necessary with a wire brush. In the State of California it is required by law (Section 4442 of the California Public Resources Code) to equip a spark arrester when a gas powered tool is used in any forest covered, brush covered, or grass covered unimproved land. (MA5)

(1) spark arrester

■ GEAR CASE (MA6)

- The reduction gears are lubricated by multipurpose, lithium-based grease in the gear case. Supply new grease every 25 hours of use or more often depending on the job condition.
- Remove the side bolt in gearcase opposite of grease nipple before installing new grease to arrange for old grease to exit.

■ INTAKE AIR COOLING VENT

▲ WARNING

- **Never touch the cylinder, muffler, or spark plugs with your bare hands immediately after stopping the engine. The engine can become very hot when in operation, and doing so could result in severe burns.**
- **When checking the machine to make sure that it is okay before using it, check the area around the muffler and remove any wood chips or leaves which have attached themselves to the brushcutter. Failing to do so could cause the muffler to become overheated, and that this in turn could cause the engine to catch on fire. Always make**

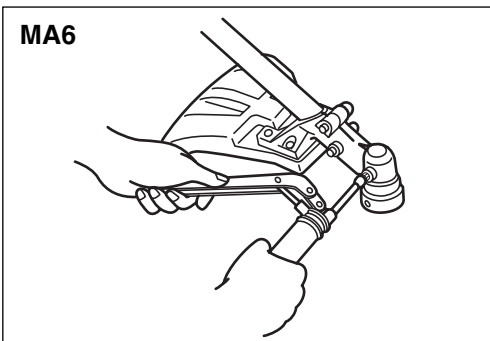
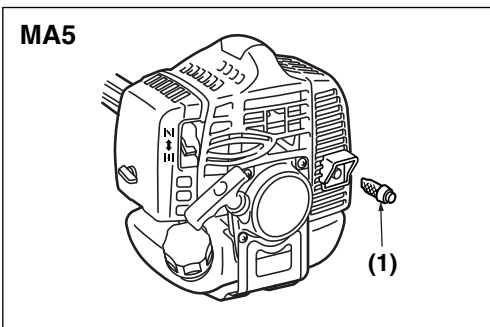

9. Maintenance

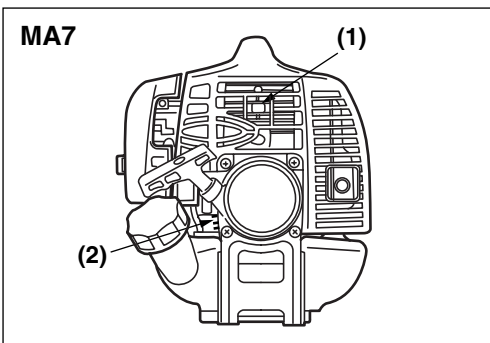

sure that the muffler is clean and free of wood chips, leaves, and other waste before use.

- Check the intake air cooling vent and the area around the cylinder cooling fins after every 25 hours of use for blockage, and remove any waste which has attached itself to the brushcutter. Note that it is necessary to remove the engine cover shown in (MA7) in order to be able to view the upper part of the cylinder.

! IMPORTANT

- If waste gets stuck and causes blockage around the intake air cooling vent or between the cylinder fins, it may cause the engine to overheat, and that in turn may cause mechanical failure on the part of the brushcutter. (MA7)

(1) cylinder

(2) intake air cooling vent (back)

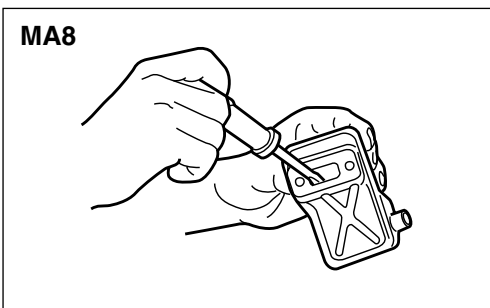

■ PROCEDURES TO BE PERFORMED AFTER EVERY 100 HOURS OF USE









1. Remove the muffler, insert a screwdriver into the vent, and wipe away any carbon buildup. Wipe away any carbon buildup on the muffler exhaust vent and cylinder exhaust port at the same time.
2. Tighten all screws, bolts, and fittings.
3. Check to see if any oil or grease has worked its way in between the clutch lining and drum, and if it has wipe it away using oil-free, lead-free gasoline.

10. Storage

- Aged fuel is one of major causes of engine starting failure. Before storing the unit, empty the fuel tank and run the engine until it uses all the fuel left in the fuel line and the carburetor. Store the unit indoor taking necessary measures for rust prevention.

11. Optional blade usage

OPT1

CUTTER APPLICATION CHART	9" 22-tooth: SST229 9" 24-tooth: SST249 	8" 8-tooth: SGB088 9" 8-tooth: SGB089 	8" 4-tooth: SGB048 9" 4-tooth: SGB049 	Nylon line head 
Under growth 	○			
Heavy weeds 		○		
Light weeds 			○	○
Grass 				○

■ CHOOSE THE BLADE

Choose a suitable recommended cutting attachment according to the object to be cut. (OPT1)

- When replacing blade always be sure to use products which have been certified by RedMax.

WARNING

- When sharpening, removing, or reattaching the blade, be sure to wear thick, sturdy gloves and use only proper tools and equipment to prevent injury.

11. Optional blade usage

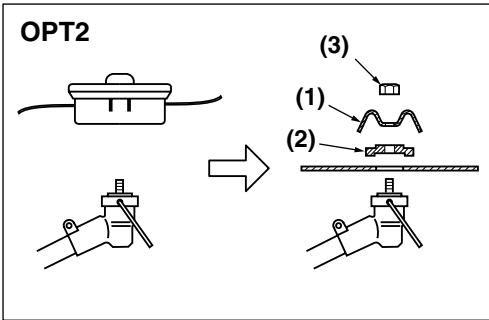

■ SET UP THE BLADE

1. Detach the line head assembly. (OPT2)
2. Put on the blade, making the marked side face the shaft side, put the holder and the cover on, and fasten the blade with the nut. (OPT2)

- (1) Cover: 3540-13283
(2) Holder (B): 6019-13250 (STANDARD)
(3) Nut: T3002-13260 (STANDARD)

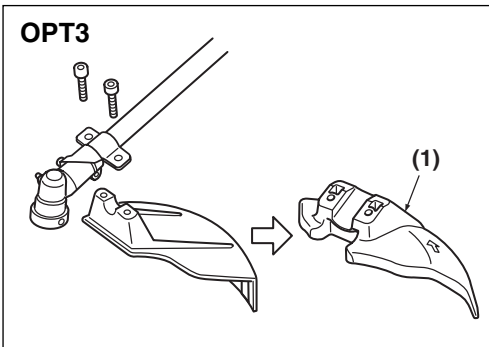

❗ IMPORTANT

[BCZ3000S/BCZ3000SW]

Change to the debris guard which is suitable for the metal blade. (OPT3)

TIGHTENING TORQUE: 26~43.5 in-lbs
(2.94~4.9 N.m.)

- (1) Guard: T3246-24110

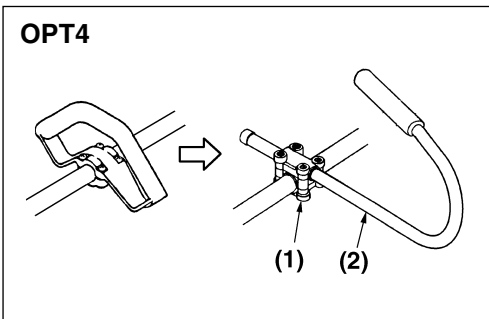

❗ IMPORTANT

[BCZ3000S]

Change the loop handle to the J-handle for safe operation. (OPT4)

- (1) Bracket: 3583-14101
(2) J-handle: 6367-14200

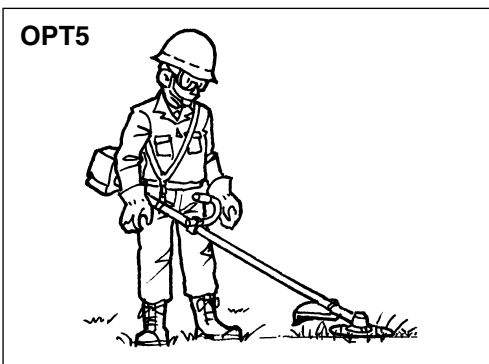

■ BALANCE UNIT

1. Put on strap and attach unit to strap.
2. Slide clamp up or down until unit balances with head just touching on the ground. (OPT5)

■ STARTING THE ENGINE

Please refer 5.For safe operation (P.9~10), 8.Operation (P.18).

⚠ WARNING

- The product is equipped with a centrifugal clutch mechanism, so the cutting attachment begins to rotate as soon as the engine is

11. Optional blade usage

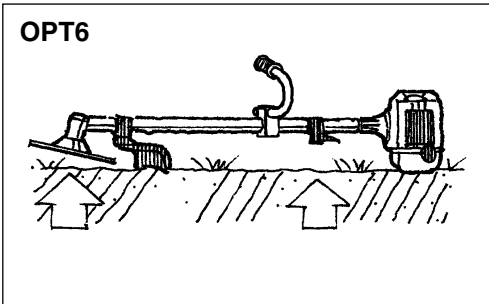

started by putting the throttle into the start position. When starting the engine, place the product onto the ground in a flat clear area and hold it firmly in place so as to ensure that neither the cutting part nor the throttle come into contact with any obstacle when the engine starts. (OPT6)

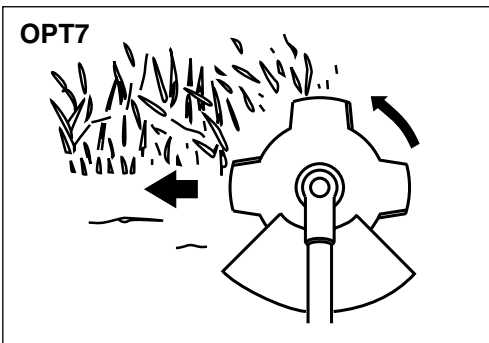

■ CUTTING METHOD

- Use the front left side cutting.
- Guide the blade from your right to left with it tilted slightly to your left. (OPT7)
- When mowing a wide area, start working from your left end to avoid interference of cut grass.
- The blade may be seized by weeds if the engine speed is too low, or the blade cuts too deep into weeds. Adjust the engine speed and cutting depth according to the condition of object.

⚠ WARNING

- If the grass or other object gets caught in the blade, or if the unit starts to shake or vibrate, turn off the engine and check the whole unit. Change the blade if it has been damaged.
- Turn off the engine and make sure the blade has completely stop before checking the blade, and removing any object got caught in.

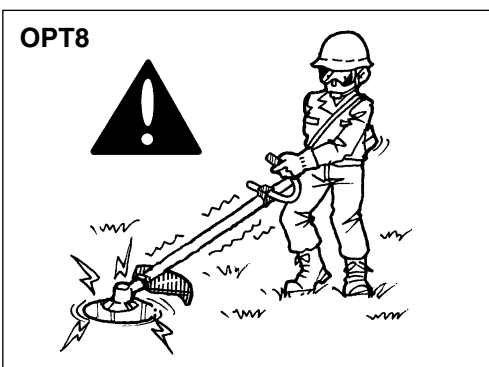

■ OPERATION

- Check the bolt to fasten the blade and be sure the bolt has no fault, and no abrasion.
- Be sure that the blade and the holder have been fastened according to instruction and the blade turns smoothly without abnormal noise. (OPT8)

⚠ WARNING

- The rotating parts fastened incorrectly may cause serious accident to the operator.
- Make sure that the blade is not bent, warped, cracked, broken or damaged.
- If you find any error to the blade, discard it and change new one which is certified by RedMax.

11. Optional blade usage

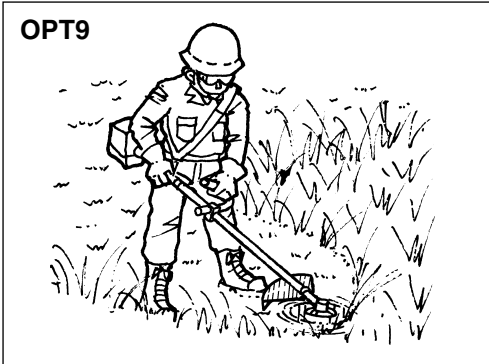

- By using the shoulder strap, hang the unit on your right side. Adjust the strap length so that the cutting head may become parallel to the ground. (OPT9)

⚠ WARNING

Make sure to use shoulder strap and debris guard. If not, it is very dangerous when you slip or lose your balance.

⚠ WARNING

■ **CONTROLLING BLADE BOUNCE**

- Kick out can cause serious personal injury. **Carefully study this section.** It is important that you understand what causes kick out, how you can reduce the chance of kick out and how you can remain in control of the unit if kick out does occur.

1. What causes kick out:

- Kick out can occur when the moving blade contacts an object that it cannot cut. This contact causes the blade to stop for an instant and then suddenly move or "bounce" away from the object that was hit. The operator can lose control of the unit and the blade can cause serious personal injury to the operator or any person nearby if the blade contacts any part of the body.

2. How you can reduce the chance of kick out:

- a. Recognize that kick out can happen. By understanding and knowing about bounce, you can help eliminate the element of surprise.
- b. **Cut fibrous weeds and grass only.** Do not let the blade contact materials it cannot cut such as hard, woody vines and brush or rocks, fences, metal, etc
- c. Be extra prepared for bounce if you must cut where you cannot see the blade making contact such as in areas of dense growth.
- d. **Keep the blade sharp.** A dull blade increase the chance of bounce.
- e. Avoid feeding the blade too rapidly. The blade can bounce away from material being cut if

11. Optional blade usage

the blade is fed faster than its cutting capability.

- f. Cut only from your right to your left.
- g. Keep your path of advance clear of material that has been cut and other debris.

3. How you can maintain the best control:

- a. Keep a good, firm grip on the unit with both hands. A firm grip can help neutralize bounce. Keep your right and left hands completely around the respective handles.
- b. Keep both feet spread apart in a comfortable stance and yet braced for the possibility that the unit could bounce. Do not overreach. Keep firm footing and balance.

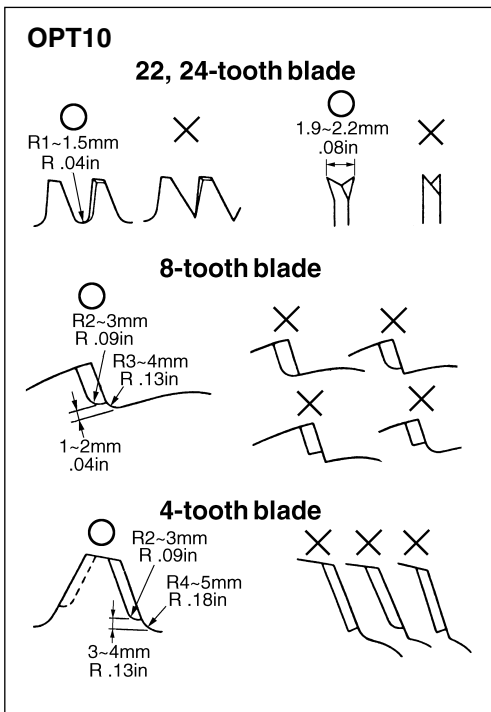

■ MAINTENANCE

BLADE

- Check the blade and the fasteners for looseness, cracking, or bending.
- Check the cutting edges and reform with a flat file.

Point (OPT10) :

1. Keep the end corner sharp.
2. Round the root of the edge, using round file.
3. Do not use water when using a grinder.

❗ IMPORTANT

- It is recommended that filing should be done by professionals.
- Especially regarding filing the 22,24-tooth blade, Leave it to the professionals.

■ TRANSPORTING THE UNIT

- When you finish cutting in one location and wish to continue work in another spot, turn off the engine, and lift up the unit and carry it paying attention for the blade.
- Never forget to place the protective cover over the blades.
- When transporting the unit over long distances, detach the blade fix the unit by ropes.

11. Troubleshooting guide

Case 1. Starting failure

CHECK		PROBABLE CAUSES		ACTION
fuel tank	→	incorrect fuel	→	drain it and with correct fuel
fuel filter	→	fuel filter is clogged	→	clean
carburetor adjustment screw	→	out of normal range	→	adjust to normal range
sparkling (no spark)	→	spark plug is fouled/wet	→	clean/dry
	→	plug gap is incorrect	→	correct (GAP: 0.6~0.7mm)
spark plug	→	disconnected	→	retighten

Case 2. Engine starts but does not keep running/Hard re-starting.

CHECK		PROBABLE CAUSES		ACTION
fuel tank	→	incorrect fuel or staled fuel	→	drain it and with correct fuel
carburetor adjustment screw	→	out of normal range	→	adjust to normal range
muffler,cylinder (exhaust port)	→	carbon is built-up	→	wipe away
air cleaner	→	clogged with dust	→	wash
cylinder fin, fan cover	→	clogged with dust	→	clean

When your unit seems to need further service, please consult with our RedMax service shop in your area.

12. Parts list

BRUSHCUTTERS

BCZ3000S
BCZ3000SW

NOTE :

1. Use KOMATSU ZENOAH genuine parts as specified in the parts list for repair and/or replacement.
2. KOMATSU ZENOAH does not warrant the machines, which have been damaged by the use of any parts other than those specified by the company.
3. When placing parts orders for repair and/or replacement, check if the model name and the serial number are applicable to those specified in the parts list, then use parts number described in the parts list.
4. The contents described in the parts list may change due to improvement.
5. The parts for the machine shall be supplied seven (7) years after the machine is discontinued. [It is possible that some specific parts may be subject to change of their delivery term and list price within the limit of seven (7) years after the machine is discontinued. It is also possible that some parts may be available even after the limit of seven (7) years.]

November 2003

APPLICABLE SERIAL NUMBERS :

DRIVE UNIT 300001 and up ENGINE UNIT 300001 and up

12. Parts list

Fig.1 DRIVE UNIT BCZ3000S (S/N 30001 and up)

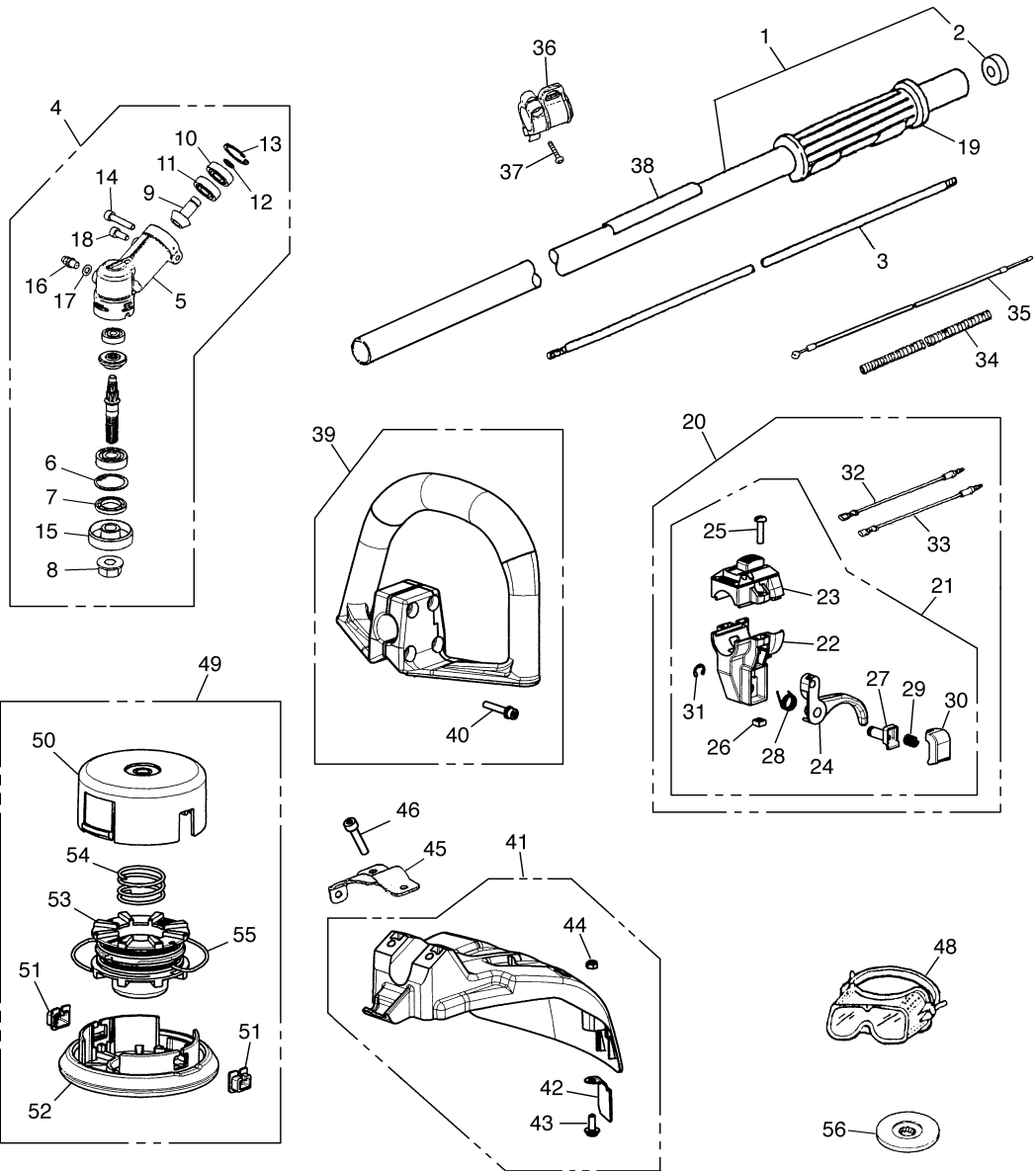

Optional Blade & Accessories

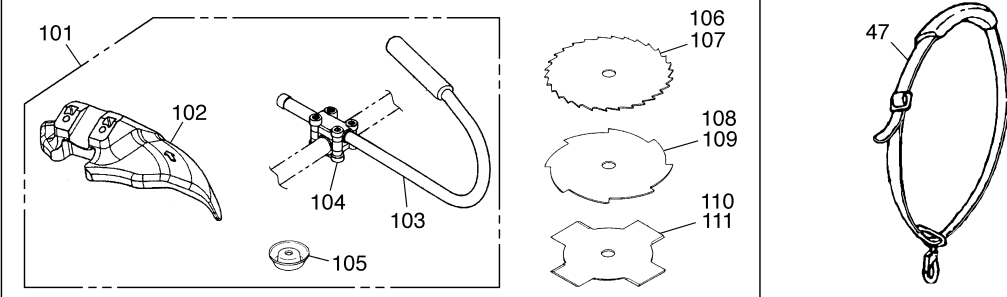

12. Parts list

Fig.2 DRIVE UNIT BCZ3000SW (S/N 30001 and up)

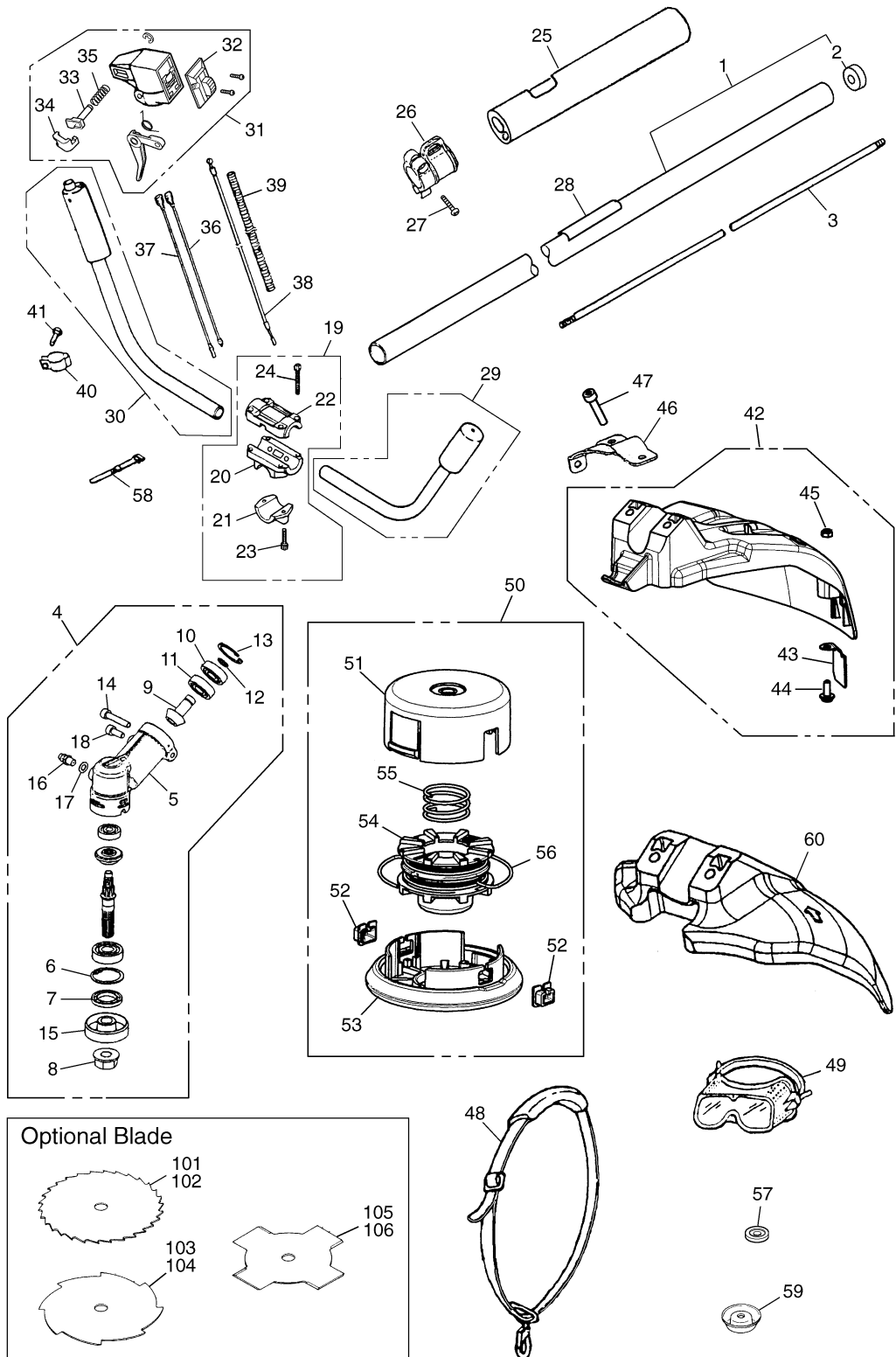

Fig.2 DRIVE UNIT BCZ3000SW (S/N 30001 and up)

Key#	Part Number	Description	Q'ty	Key#	Part Number	Description	Q'ty
1	T3108-12100	PIPE-C	1	51	T3189-15112	• CASE	1
2	T3400-12130	• SEAL	1	52	T3189-15191	• EYELET	2
3	3520-12213	SHAFT	1	53	T3189-15132	• COVER	1
4	848-JC0-6100	GEARCASE-A	1	54	T3189-15142	• CORD HOLDER	1
5	6440-13122	• GEARCASE	1	55	T3189-15160	• SPRING	1
6	04065-02612	• SNAP RING	1	56	T3189-15180	• CORD	1
7	3565-13130	• SEAL	1	57	6019-13250	HOLDER (B)	1
8	T3002-13260	• NUT	1	58	3540-93120	BAND	1
9	848-JC0-61D0	• PINION	1	59	3540-13283	COVER	1
10	T3300-13531	• BEARING	1	60	T3246-24110	GUARD	1
11	T3403-13530	• BEARING (0600000609)	1	OPTIONAL BLADE			
12	T3300-13330	• SNAP RING	1	101	SST229	9" 22-tooth	1
13	04065-02412	• RING (0243224120)	1	102	SST249	9" 24-tooth	1
14	T4950-52500	• BOLT TORX, 5x25	1	103	SGB088	8" 8-tooth	1
15	6440-13242	• HOLDER (A)	1	104	SGB089	9" 8-tooth	1
16	3199-13350	• FITTI (2087061640)	1	105	SGB048	8" 4-tooth	1
17	01641-20608	• WASHER	1	106	SGB049	9" 4-tooth	1
18	T4950-51200	• BOLT TORX, 5x12	1				
19	848-JC1-3230	BRACKET-A	1				
20	3583-14111	• BRACKET	1				
21	3583-14121	• CAP (L)	1				
22	3257-14192	• CAP (U)	1				
23	4820-13180	• BOLT	2				
24	T4950-52500	• BOLT	4				
25	T3310-17111	PROTECTOR	1				
26	T3300-17202	HANGER-C	1				
27	848-805-2000	SCREW TORX, 5x20	1				
28	848-JC1-90R1	NAME PLATE	1				
29	T3040-14200	HANDLE (L)-C	1				
30	T3002-95400	HANDLE (R)-C	1				
31	6234-14601	LEVER-A	1				
32	6234-14601-02	• COVER (E54135700811)	1				
33	6110-14410-06	• SHAFT	1				
34	6110-14410-09	• BUTTON	1				
35	6110-14410-08	• SPRING	1				
36	T3002-95710	CORD (A), black	1				
37	T3002-95720	CORD (B), red	1				
38	T3040-83100	CABLE-C	1				
39	5512-73220	TUBE	1				
40	3260-14251	CLAMP	1				
41	0260-00516	SCREW	1				
42	848-JC0-6610	GUARD-C	1				
43	T3002-24121	• BLADE	1				
44	T4960-51431	• SCREW TORX, 5x14	1				
45	3320-15310	• NUT	1				
46	848-JC0-66C1	BRACKET	1				
47	T4950-63000	BOLT TORX, 6x30	2				
48	848-B50-3610	STRAP-A	1				
49	T3002-91190	GOGGLE	1				
50	PT104 Plus	TAP HEAD-C	1				

12. Parts list

Fig.3 ENGINE UNIT

BC3000S (S/N 30001 and up)

BC3000SW (S/N 30001 and up)

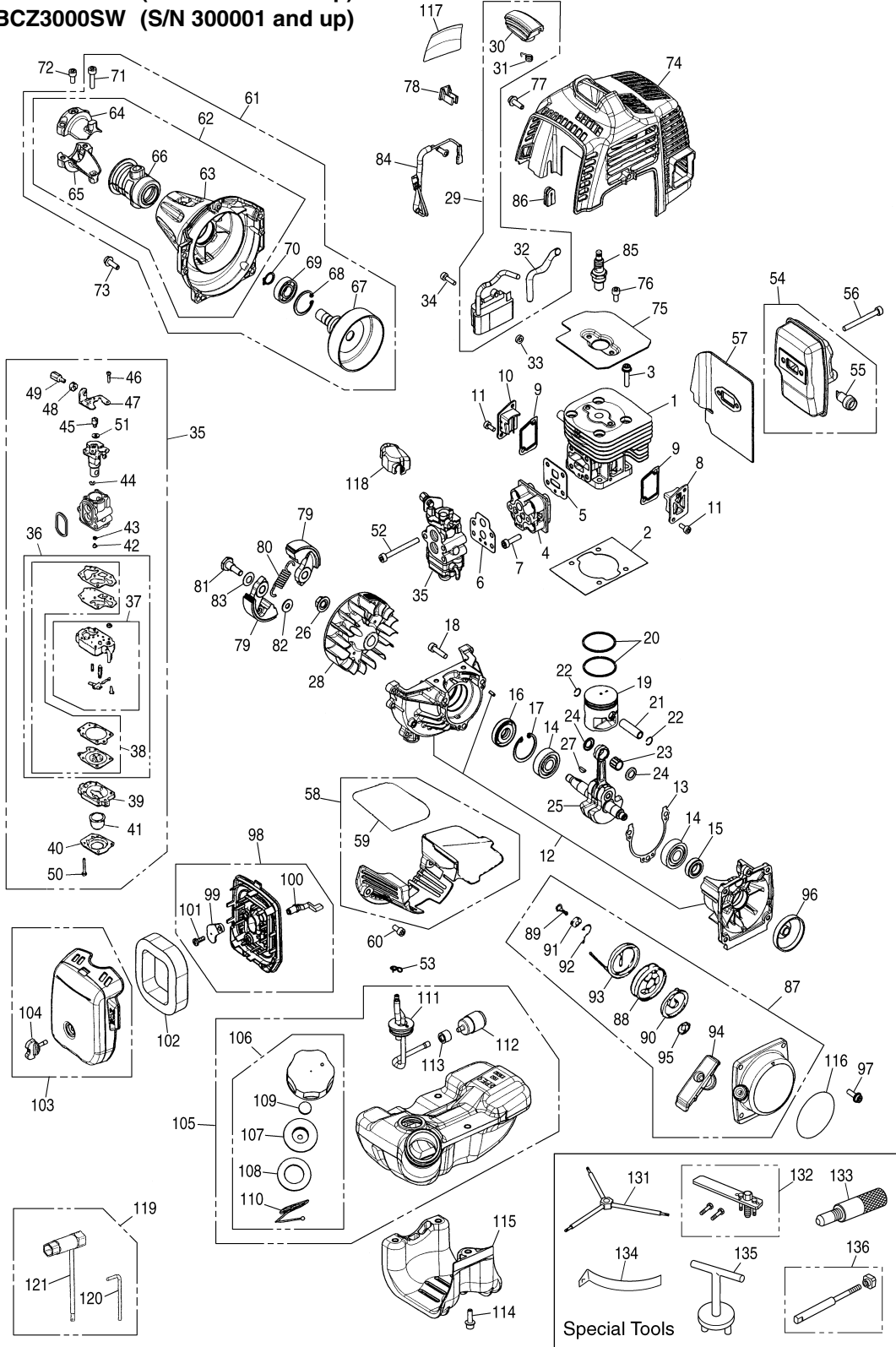

BCZ3000S (S/N 30001 and up)

Fig.3 ENGINE UNIT BCZ3000SW (S/N 30001 and up)

Key#	Part Number	Description	Q'ty	Key#	Part Number	Description	Q'ty
1	848-F60-12A1	CYLINDER	1	67	T1590-31120	• DRUM	1
2	T1590-12210	GASKET, base	1	68	04065-02812	• SNAP RING	1
3	4820-12130	BOLT TORX	4	69	T1701-31150	• BEARING	1
4	848-F60-14A1	INSULATOR	1	70	04064-01210	• SNAP RING	1
5	T1590-13120	GASKET, insu	1	71	4820-13180	• BOLT TORX	2
6	T1590-13130	GASKET, carb	1	72	4820-12350	BOLT TORX	1
7	T4950-52021	BOLT TORX	4	73	4820-85510	BOLT TORX	4
8	848-F60-12C1	COVER, trs	1	74	848-F60-31A1	COVER, engine	1
9	848-F60-12E1	GASKET, tr	2	75	848-F60-12G1	PLATE, cyl	1
10	848-F60-12D2	COVER, trf	1	76	4820-12350	BOLT TORX	2
11	4820-16310	BOLT TORX	4	77	4820-32120	BOLT TORX	2
12	848-F60-2111	CRANKCASE-C	1	78	T1600-72210	CLAMP	1
13	848-F60-21D1	GASKET, case	1	79	T1590-51110	SHOE	2
14	848-89C-3200	BEARING	2	80	848-8E9-3700	SPRING	1
15	4810-21210	SEAL	1	81	1140-51250	SCREW	2
16	1650-21220	SEAL	1	82	1140-51230	WASHER	2
17	04065-03212	SNAP RING	2	83	848-872-8000	WASHER, wave	2
18	4820-13180	BOLT TORX	3	84	T1551-73200	CORD-C	1
19	848-F60-41A1	PISTON	1	85	T2070-73110	SPARK PLUG	1
20	T1590-41210	RING	2	86	4810-72120	GROMMET	1
21	T2200-41310	PIN	1	87	T1551-75100	RECOIL-A	1
22	3310-41320	SNAP RING	2	88	4500-75120	• REEL	1
23	3310-41410	BEARING	1	89	4500-75150	• SCREW	1
24	1650-41510	WASHER	2	90	1850-75130	• SPRING	1
25	848-F60-4201	CRANKSHAFT-C	1	91	4500-75180	• COLLAR	1
26	1650-43230	NUT	1	92	4500-75190	• ARM	1
27	1000-43240	KEY	1	93	4810-75160	• ROPE	1
28	T1700-71110	ROTOR	1	94	3330-75421	• KNOB	1
29	T1590-71200	COIL-A	1	95	4810-75170	• PLATE	1
30	4810-72111	• CAP	1	96	4500-75210	PULLEY	1
31	T1108-72120	• SPRING	1	97	4820-32120	BOLT TORX	4
32	2850-71320	• TUBE	1	98	T1551-82100	BODY-A	1
33	1260-71261	SPACER	2	99	T1512-82130	• PLATE, choke	1
34	4820-72150	BOLT TORX	2	100	T1600-82140	• LEVER	1
35	848-F60-8101	CARBURETOR-A	1	101	T1108-82190	• SCREW	1
36	848-F60-0630	• REBUILD KIT	1	102	T1551-82170	ELEMENT	1
37	1850-81450	•• BODY-A	1	103	T1551-82200	COVER-A	1
38	4810-06021	• GASKET KIT	1	104	T1108-82220	• KNOB	1
39	1850-81490	• BODY, purge	1	105	848-F60-8501	TANK-A	1
40	1850-81520	• COVER, pump	1	106	T1015-85202	• CAP-A	1
41	1751-81510	• PUMP, priming	1	107	4500-85300	•• HOLDER-A	1
42	4810-81251	• JET	1	108	4500-85220	•• PACKING	1
43	1751-81240	• O-RING	1	109	5601-85260	•• FILTER	1
44	1751-81130	• RING	1	110	4820-85260	•• STOPPER	1
45	1881-81140	• SWIVEL	1	111	848-F60-8530	• PIPE-C	1
46	1752-81110	• SCREW	2	112	3302-85400	• FILTER-A	1
47	5500-81120	• BRACKET	1	113	2841-31280	• COLLAR	1
48	1751-81180	• NUT, adjuster	1	114	T4950-52030	BOLT TORX	3
49	1918-81170	• SCREW, adjuster	1	115	848-F60-85Z0	GUARD, tank	1
50	1850-81530	• SCREW	4	116	848-F60-90C0	LABEL, recoil	1
51	5500-81160	• WASHER	1	117	848-F60-90B0	LABEL	1
52	4820-15310	BOLT TORX	2	118	4500-81910	COVER	1
53	1950-86120	CLIP	1	119	T1551-91000	TOOL SET	1
54	4810-15100	MUFFLER-A	1	120	3540-91110	• BAR	1
55	4810-15140	• ARRESTER	1	121	T4017-91130	• SOCKET	1
56	4820-15310	BOLT TORX	2				
57	848-F60-15C0	GASKET, muff	1				
58	848-F60-1530	PLATE-A	1				
59	848-F60-15F0	• SHEET	1				
60	4820-12350	BOLT TORX	2	131	2850-96410	HEXAGON WRENCH	1
61	848-F60-5301	HOUSING-A	1	132	2890-96100	PULLER-A	1
62	T1590-31100	• HOUSING-C	1	133	4810-96220	STOPPER	1
63	T1590-31110	•• HOUSING	1	134	3350-96240	GAUGE	1
64	T1700-31212	•• BRACKET (A)	1	135	4500-96100	PULLER	1
65	T1700-31221	•• BRACKET (B)	1	136	848-8W1-0000	ROD-A	1
66	T1700-31232	•• CUSHION	1				
SPECIAL TOOLS							

CALIFORNIA EMISSION CONTROL WARRANTY STATEMENT
YOUR WARRANTY RIGHTS AND OBLIGATIONS

The California Air Resources Board and KOMATSU ZENOAH are pleased to explain the **emission control system warranty** on your **1995 and later** small off-road engine. In California, new small off-road engines must be designed, built and equipped to meet the state's stringent anti-smog standards. KOMATSU ZENOAH must warrant the emission control system on your small off-road engine for the periods of time listed below provided there has been no abuse, neglect or improper maintenance of your small off-road engine.

Your emission control system may include parts such as the carburetor and the ignition system.

Where a warrantable condition exists, KOMATSU ZENOAH will repair your small off-road engine at no cost to you including diagnosis, parts and labor.

Manufacturer's warranty coverage:

The 1995 and later small off-road engines are warranted for **two years**. If any emission-related part on your engine is defective, the part will be repaired or replaced by KOMATSU ZENOAH.

Owner's warranty responsibilities:

– As the small off-road engine owner, you are responsible for the performance of the **required maintenance listed in your owner's manual**. KOMATSU ZENOAH recommends that you retain all receipts covering maintenance on your small off-road engine, but KOMATSU ZENOAH can not deny warranty solely for the lack of receipts or for your failure to ensure the performance of all scheduled maintenance.

– As the small off-road engine owner, you should be aware, however, that KOMATSU ZENOAH may deny you warranty coverage if your small off-road engine or a part has failed due to abuse, neglect, improper maintenance or unapproved modification.

– You are responsible for presenting your small off-road engine to a KOMATSU ZENOAH distribution center as soon as a problem exists. The warranty repairs should be completed in a reasonable amount of time, not to exceed **30 days**.

If you have any questions regarding your warranty rights and responsibilities, you should contact KOMATSU ZENOAH AMERICA INC. at (770)-381-5147 or you can write to

KOMATSU ZENOAH AMERICA INC.
4344 Shackleford Road Suite 500
Norcross, Georgia 30093

RedMax

LIMITED WARRANTY

EMISSION-RELATED PARTS, FOR TWO (2) YEARS FROM THE DATE OF ORIGINAL DELIVERY OF THE UNIT, KOMATSU ZENOAH AMERICA INC. (THE COMPANY), THROUGH ANY RedMax DEALER, WILL REPAIR OR REPLACE, FREE OF CHARGE, FOR THE ORIGINAL AND EACH SUBSEQUENT PURCHASER, ANY PART OR PARTS FOUND TO BE DEFECTIVE IN MATERIAL AND/OR WORKMANSHIP. EMISSION-RELATED PARTS ARE:

**THE CARBURETOR ASSY, COIL ASSY, ROTOR, SPARKPLUG,
AIR FILTER, FUEL FILTER, INTAKE MANIFOLD, AND THE GASKETS**

ALL OTHER PARTS EXCEPT ABOVE PARTS, FOR TWO (2) YEARS OF USE, 90 DAYS FOR RENTAL USE, FROM THE DATE OF ORIGINAL PURCHASE, THE COMPANY, THROUGH ANY RedMax DEALER, WILL REPAIR OR REPLACE, FREE OF CHARGE, FOR THE ORIGINAL PURCHASER, ANY PART OF PARTS FOUND TO BE DEFECTIVE IN MATERIAL AND/OR WORKMANSHIP. **THIS IS THE EXCLUSIVE REMEDY.**

THE PURCHASER SHALL BEAR COSTS OF TRANSPORTING THE UNIT TO AND FROM THE RedMax DEALER.

THE PURCHASER SHALL NOT BE CHARGED FOR DIAGNOSTIC LABOR WHICH LEADS TO THE DETERMINATION THAT A WARRANTED PART IS DEFECTIVE, IF THE DIAGNOSTIC WORK IS PERFORMED AT THE RedMax DEALER.

THE PURCHASER OR OWNER IS RESPONSIBLE FOR THE PERFORMANCE OF THE REQUIRED MAINTENANCE AS DEFINED BY THE MANUFACTURER IN THE OWNER/OPERATOR MANUAL.

ANY WARRANTED PART WHICH IS NOT SCHEDULED FOR REPLACEMENT AS REQUIRED MAINTENANCE, OR WHICH IS SCHEDULED ONLY FOR REGULAR INSPECTION TO THE EFFECT OF "REPAIR OR REPLACE AS NECESSARY" SHALL BE WARRANTED FOR THE WARRANTY PERIOD. ANY WARRANTED PART WHICH IS SCHEDULED FOR REPLACEMENT AS REQUIRED MAINTENANCE SHALL BE WARRANTED FOR THE PERIOD OF TIME UP TO THE FIRST SCHEDULED REPLACEMENT POINT FOR THE PART.

ANY REPLACEMENT PART THAT IS EQUIVALENT IN PERFORMANCE AND DURABILITY MAY BE USED IN NON-WARRANTY MAINTENANCE OR REPAIRS, AND SHALL NOT REDUCE THE WARRANTY OBLIGATION OF THE COMPANY.

THE COMPANY IS LIABLE FOR DAMAGES TO OTHER ENGINE COMPONENTS CAUSED BY THE FAILURE OF A WARRANTED PARTS STILL UNDER WARRANTY.

THE WARRANTY DOES NOT APPLY TO THOSE UNITS WHICH HAVE BEEN DAMAGED BY NEGLIGENCE OF INSTRUCTION LISTED IN THE OWNER/OPERATOR MANUAL FOR PROPER USE AND MAINTENANCE OF THE UNITS, ACCIDENT MISHANDLING, ALTERATION, ABUSE, IMPROPER LUBRICATION, USE OF ANY PARTS OR ACCESSORIES OTHER THAN THOSE SPECIFIED BY THE COMPANY, OR OTHER CAUSES BEYOND THE COMPANY'S CONTROL.

THIS WARRANTY DOES NOT COVER THOSE PARTS REPLACED BY NORMAL WEAR OR HARMLESS CHANGES IN THEIR APPEARANCE.

THERE ARE NO OTHER EXPRESS WARRANTIES.

IMPLIED WARRANTIES INCLUDING THOSE OF MERCHANTABILITY AND FITNESS FOR A PARTICULAR PURPOSE **ARE LIMITED** TO TWO (2) YEARS OF USE FROM THE ORIGINAL DELIVERY DATE.

LIABILITIES FOR INCIDENTAL OR CONSEQUENTIAL DAMAGE UNDER ANY AND ALL WARRANTIES ARE EXCLUDED.

SOME STATES DO NOT ALLOW LIMITATION ON HOW LONG AN IMPLIED WARRANTY LASTS OR EXCLUSION OR LIMITATION OF INCIDENTAL OR CONSEQUENTIAL DAMAGES, SO THE ABOVE LIMITATION OR EXCLUSION MAY NOT APPLY TO YOU.

THIS WARRANTY GIVES YOU SPECIFIC LEGAL RIGHTS, AND YOU MAY ALSO HAVE OTHER RIGHTS WHICH VARY FROM STATE TO STATE.

IF YOU NEED TO OBTAIN INFORMATION ABOUT THE NEAREST SERVICE CENTER, PLEASE CALL KOMATSU ZENOAH AMERICA INC. AT (770)-381-5147.

IMPORTANT: YOU WILL RECEIVE A WARRANTY REGISTRATION CARD AT TIME OF PURCHASE. PLEASE FILL OUT THE CARD AND SEND IT TO RedMax / KOMATSU ZENOAH AMERICA WITHIN SEVEN (7) DAYS. BE SURE TO KEEP A COPY FOR YOUR RECORDS.



KOMATSU ZENOAH AMERICA INC.
4344 Shackleford Road Suite 500
Norcross, Georgia 30093

RedMax Garantie limitée

Pièces en rapport avec les émissions de gaz d'échappement : KOMATSU ZENOAH AMERICA INC., par l'intermédiaire de n'importe quel revendeur RedMax, réparera gratuitement ou remplacera gratuitement pour l'acheteur initial et chaque acheteur successif toute(s) pièce(s) se révélant de constitution et/ou de montage défectueux pendant deux (2) ans à compter de la date initiale de livraison d'une unité. Les pièces en rapport avec les émissions de gaz d'échappement sont:

**l'assemblage carburateur, l'assemblage bobine, le rotor, la bougie,
le filtre à air, le filtre à carburant, la tubulure d'admission et les joints**

Toutes les pièces autres que celles mentionnées ci-dessus, deux (2) ans d'utilisation, 90 jours pour la location, à compter de la date d'achat initial. La société, par l'intermédiaire d'un distributeur RedMax, réparera ou remplacera toute(s) pièce(s), sans frais et au bénéfice de l'acheteur original, en prenant en charge les frais de pièces et/ou de main d'œuvre. **Telles sont les limites de la garantie.**

Le coût du transport de l'unité jusqu'au revendeur RedMax et depuis celui-ci sera à la charge de l'acheteur.

L'acheteur ne supportera pas le coût de main d'œuvre du diagnostic qui amène à la conclusion qu'une pièce garantie est défectueuse, si ce diagnostic est effectué chez le revendeur RedMax.

L'acheteur ou propriétaire a pour responsabilité d'effectuer l'entretien obligatoire tel que défini par le fabricant dans le manuel du propriétaire/de l'utilisateur.

Toute pièce garantie dont le remplacement n'est pas prévu dans le cadre de l'entretien obligatoire, ou pour laquelle est seulement prévue une inspection périodique pour "remplacement ou réparation si nécessaire" sera garantie pour la période de garantie. Toute pièce garantie arrivée à l'échéance de son premier remplacement prévu sera garantie jusqu'à celui-ci.

Toute pièce de rechange équivalente en performance ou en durabilité peut être utilisée pour l'entretien hors-garantie ou les réparations hors-garantie, et ce sans réduire l'obligation de garantie incombant à la société.

La société sera tenue responsable des dommages aux autres composants du moteur causés par la défaillance de pièce(s) garantie(s) en période de garantie.

La garantie ne s'applique pas aux unités endommagées par suite de: négligence dans la mise en oeuvre des instructions spécifiées dans le manuel du propriétaire/de l'utilisateur en vue d'une utilisation et d'un entretien correct, fausse manœuvre accidentelle, modification, utilisation abusive, lubrification incorrecte, utilisation de pièces ou d'accessoires autres que ceux spécifiés par la société, ou autres causes hors du contrôle de la société.

Cette garantie ne couvre pas les pièces remplacées en raison de leur usure normale ou de changements d'apparence sans effets.

Il n'existe aucune autre garantie explicite.

Les garanties implicites, y compris la valeur marchande et la valeur d'usage pour une utilisation particulière, **sont limitées** à deux (2) ans d'utilisation à compter de la date originale de livraison.

Les responsabilités pour les dommages conséquents ou incidents sont exclues de toutes les garanties.

Certaines provinces n'autorisent pas les limitations à la durée des garanties implicites, ou les exclusions ou limitations relatives aux dommages incidents ou conséquents, la limitation indiquée ci-dessus peut ne pas vous être applicable.

Cette garantie vous donne des droits juridiques spécifiques, et vous pouvez également jouir d'autres droits variant d'une province à l'autre.

Si vous désirez obtenir des informations sur le centre de service le plus proche, veuillez appeler KOMATSU ZENOAH AMERICA INC. au (770)-381-5147

Note importante: vous recevrez une carte d'enregistrement de garantie au moment de l'achat. Veuillez la remplir et l'adresser à RedMax / KOMATSU ZENOAH AMERICA sous sept (7) jours en prenant soin de conserver une copie pour vous.



KOMATSU ZENOAH AMERICA INC.
4344 Shackelford Road Suite 500
Norcross, Georgia 30093

Printed in U.S.A.

Free Manuals Download Website

<http://myh66.com>

<http://usermanuals.us>

<http://www.somanuals.com>

<http://www.4manuals.cc>

<http://www.manual-lib.com>

<http://www.404manual.com>

<http://www.luxmanual.com>

<http://aubethermostatmanual.com>

Golf course search by state

<http://golfingnear.com>

Email search by domain

<http://emailbydomain.com>

Auto manuals search

<http://auto.somanuals.com>

TV manuals search

<http://tv.somanuals.com>