

# Use, Care, and Installation Guide

## Typhoon

AK2100  
AK2136  
AK2142  
AK2148

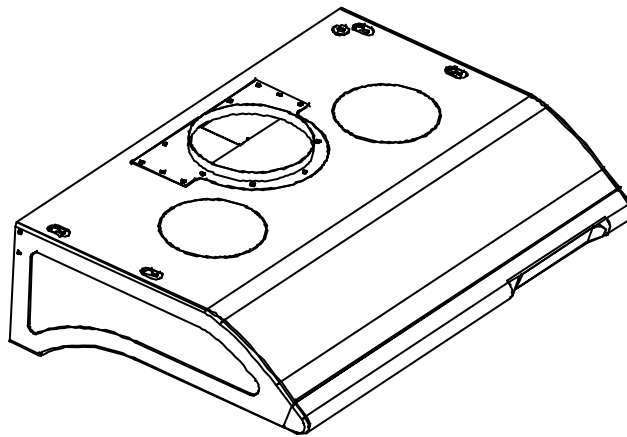

Model number: \_\_\_\_\_  
Serial number: \_\_\_\_\_  
Dealer Name: \_\_\_\_\_  
Date of Purchase: \_\_\_\_\_

NOV06.0201© Zephyr Corporation





**SAFETY NOTICE** ..... 2  
**LIST OF MATERIALS** ..... 3

**INSTALLATION**

- Ducting Calculation Sheet ..... 4
- Mounting Height and Clearance ..... 5
- Ducting ..... 6
- Specifications ..... 7
- Installing the Hood ..... 8-11
- Convertible Ducting Options ..... 12
- 3 1/4" x 10" Rear Discharge ..... 13

**FEATURES & CONTROLS**

- Features & Controls ..... 14-16

**MAINTENANCE**

- Self Cleaning Feature ..... 17
- Cleaning ..... 18
- Lights ..... 18

**TROUBLE SHOOTING** ..... 19  
**WARRANTY** ..... 20  
**LIST OF ACCESSORIES/PARTS** ..... 21  
**EXPLODED VIEW DIAGRAM** ..... 22-24

**READ AND SAVE THESE INSTRUCTIONS****Important safety Notice****WARNING**

TO REDUCE THE RISK OF FIRE OR ELECTRIC SHOCK, DO NOT USE THIS FAN WITH ANY SOLID-STATE SPEED CONTROL DEVICE.

**WARNING**

TO REDUCE THE RISK OF FIRE, ELECTRIC SHOCK, OR INJURY TO PERSONS, OBSERVE THE FOLLOWING:

- a. Use this unit only in the manner intended by the manufacturer. If you have questions, contact the manufacturer.
- b. Before servicing or cleaning unit, switch power off at service panel and lock the service disconnecting means to prevent power from being switched on accidentally.  
When the service disconnecting means cannot be locked, securely fasten a prominent warning device, such as tag, to the service panel.

**CAUTION**

For General Ventilating Use Only. Do not Use to Exhaust Hazardous or Explosive Materials and Vapors.  
Take care when using cleaning agents or detergents. Suitable for use in household cooking area.

**WARNING**

TO REDUCE THE RISK OF A RANGE TOP GREASE FIRE:

- a. Never leave surface units unattended at high settings. Boilovers cause smoking and greasy spillovers that may ignite. Heat oils slowly on low or medium settings.
- b. Always turn hood ON when cooking at high heat or when cooking flaming food (i.e. Crepes Suzette, Cherries Jubilee, Peppercorn Beef Flambe)
- c. Clean ventilating fans frequently. Grease should not be allowed to accumulate on fan or filter.
- d. Use proper pan size. Always use cookware appropriate for the size of the surface element.
- e. Keep fan, filters and grease laden surfaces clean.
- f. Use high setting on hood only when necessary.
- g. Don't leave hood unattended when cooking.
- h. Always use cookware and utensils appropriate for the type of and amount of food being prepared.

**WARNING**

TO REDUCE THE RISK OF INJURY TO PERSONS IN THE EVENT OF A RANGE TOP GREASE FIRE, OBSERVE THE FOLLOWING:

- a. SMOTHER FLAMES with a close-fitting lid, cookie sheet, or metal tray, then turn off the burner. BE CAREFUL TO PREVENT BURNS.  
If the flames do not go out immediately, EVACUATE AND CALL THE FIRE DEPARTMENT.
- b. NEVER PICK UP A FLAMING PAN - You may be burned.
- c. DO NOT USE WATER, including wet dishcloths or towels - a violent steam explosion will result.
- d. Use an extinguisher ONLY if:
  1. You know you have a class ABC extinguisher, and you already know how to operate it.
  2. The fire is small and contained in the area where it started.
  3. The fire department is being called.
  4. You can fight the fire with your back to an exit.
  5. Based on "Kitchen Fire Safety Tips" published by NFPA.

**WARNING**

TO REDUCE THE RISK OF FIRE, ELECTRIC SHOCK OR INJURY TO PERSONS, OBSERVE THE FOLLOWING:

- a. Installation Work and Electrical Wiring Must be Done by Qualified Person (s) In Accordance with all Applicable Codes and Standards, Including Fire-Rated Construction.
- b. Sufficient air is needed for proper combustion and exhausting of gases through the flue (chimney) of fuel burning equipment to prevent back drafting. Follow the heating equipment manufacturer's guideline and safety standards such as those published by the National Fire Protection Association (NFPA), and the American Society for Heating, Refrigeration, and Air Conditioning Engineers (ASHRAE) and the local code authorities.
- c. When cutting or drilling into wall or ceiling, do not damage electrical wiring and other hidden utilities.
- d. Ducted fans must always vent to the outdoors.
- e. If this unit is to be installed over a tub or shower, it must be marked as appropriate for the application and be connected to a GFCL (Ground Fault Interrupter protected branch circuit).
- g. NEVER place a switch where it can be reached from a tub or shower.
- h. Make sure the power is off before installing, wiring or maintaining.

**WARNING**

TO REDUCE THE RISK OF FIRE, USE ONLY METAL DUCTWORK.

**CAUTION**







To reduce risk of fire and to properly exhaust air, be sure to duct air outside - Do not vent exhaust air into spaces within walls or ceilings or into attics, crawl spaces or garages.



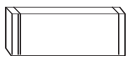

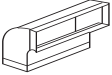
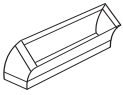

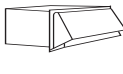
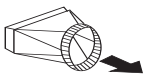
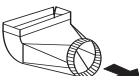
- 1-Hood
- 2-Halogen Light bulbs. 35W, GU-10

- 1 –Hardware packet containing:
  - 1-Rectangular transition adapter
  - 1-Rectangular starting collar
  - 1-7" round collar
  - 2-Safety grills
  - 2-Residue cups
  - 3-Wire connector caps 18g
  - 4- 5mm diameter big washers
  - 4- 5mm diameter small washers
  - 4- ST4\*15(mm) round head drywall screws(with gasket)
  - 4- ST4\*45(mm) round head drywall screws
  - 4- ST4\*34(mm) round head drywall screws
  - 4- ST4\*22(mm) round head drywall screws

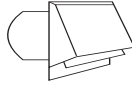
**NO DUCTING IS INCLUDED**

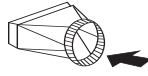
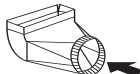
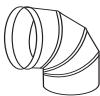
# Installation - Ductwork Calculation Sheet

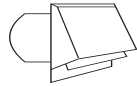
Duct pieces		Equivalent number length x used =	Total
	3 1/4" x 10" Rect, straight	1 Ft. x ( ) =	Ft.
	7" Round, straight	1 Ft. x ( ) =	Ft.
	7" Round, straight	1 Ft. x ( ) =	Ft.
	3 1/4" x 10" Rect. 90° elbow	15 Ft. x ( ) =	Ft.
	3 1/4" x 10" Rect. 45° elbow	9 Ft. x ( ) =	Ft.
	3 1/4" x 10" Rect. 90° flat elbow	24 Ft. x ( ) =	Ft.
	3 1/4" x 10" Rect. wall cap with damper	30 Ft. x ( ) =	Ft.
	3 1/4" x 10" Rect. to 6" round transition	5 Ft. x ( ) =	Ft.
	3 1/4" x 10" Rect. to 6" round transition 90° elbow	15 Ft. x ( ) =	Ft.
	6" Round, 90° elbow	15 Ft. x ( ) =	Ft.
	6" Round, 45° elbow	9 Ft. x ( ) =	Ft.
Subtotal column 1 =			Ft.

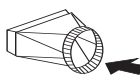
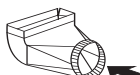
Duct pieces		Equivalent number length x used =	Total
	6" Round wall cap with damper	30 Ft. x ( ) =	Ft.
	6" Round, roof cap	30 Ft. x ( ) =	Ft.
	6" round to 3 1/4" x 10" rect. transition	1 Ft. x ( ) =	Ft.
	6" round to 3 1/4" x 10" rect. transition 90° elbow	16 Ft. x ( ) =	Ft.
	7" Round, 90° elbow	15 Ft. x ( ) =	Ft.
	7" Round, 45° elbow	9 Ft. x ( ) =	Ft.
	7" Round wall cap with damper	30 Ft. x ( ) =	Ft.
	7" Round, roof cap	30 Ft. x ( ) =	Ft.
	7" round to 3 1/4" x 10" rect. transition	8 Ft. x ( ) =	Ft.
	7" round to 3 1/4" x 10" rect. transition 90° elbow	15 Ft. x ( ) =	Ft.
Subtotal column 2 =			Ft.
Subtotal column 1 =			Ft.
Total ductwork =			Ft.

**Maximum Duct Length:** For satisfactory air movement, the total duct length of a 3 1/4" x 10" rectangular, 6" or 7" diameter round duct should not exceed 100 equivalent feet.

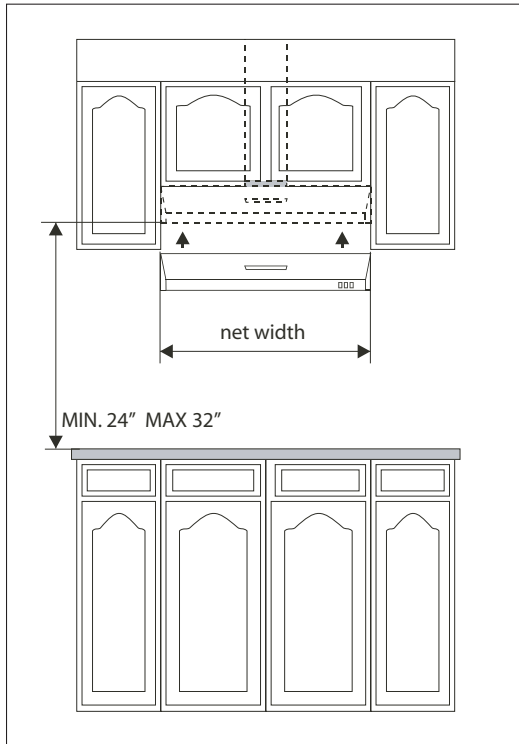

Minimum mount height between range top to hood bottom should be no less than 24".

Maximum mount height should be no higher than 32".

It is important to install the hood at the proper mounting height. Hoods mounted too low could result in heat damage and fire hazard; while hoods mounted too high will be hard to reach and will lose its performance and efficiency.

If available, also refer to range manufacturer's height clearance requirements and recommended hood mounting height above range. Always check your local codes for any differences.

Call Out Size	Net Width
30"	29 3/4"
36"	35 3/4"
42"	41 3/4"
48"	47 3/4"

## DUCTING

A minimum of 7" round or 3-1/4 x 10" rectangular duct must be used to maintain maximum air flow efficiency.

Always use rigid type metal ducts only. Flexible ducts could restrict air flow by up to 50%.

Use calculation worksheet to compute total duct work.

ALWAYS, when possible, reduce the number or transitions and turns. If long duct run is required, increase duct size from 7" to 8". If a reducer is used, install a long reducer instead of a pancake reducer. Reduce duct size as far away from opening as possible.

If turns or transitions are required: Install as far away from opening and as far apart, between 2, as possible.

### Minimum Duct Size:

Round- 7" minimum  
Rectangular- 3-1/4 x 10" minimum  
(rear or top)

### DAMAGE-SHIPMENT / INSTALLATION:

- Please fully inspect unit for damage before installation.
- If the unit is damaged in shipment, return the unit to the store in which it was bought for repair or replacement.
- If the unit is damaged by the customer, repair or replacement is the responsibility of the customer.
- If the unit is damaged by the installer (if other than the customer), repair or replacement must be made by arrangement between customer and installer.

# Installation - Ducting

## WARNING FIRE HAZARD

NEVER exhaust air or terminate duct work into spaces between walls, crawl spaces, ceiling, attics or garages. All exhaust must be ducted to the outside, unless using the recirculating option.

Use single wall rigid Metal ductwork only.

Fasten all connections with sheet metal screws and tape all joints w/ certified Silver Tape or DuctTape.

Some Ducting Options:

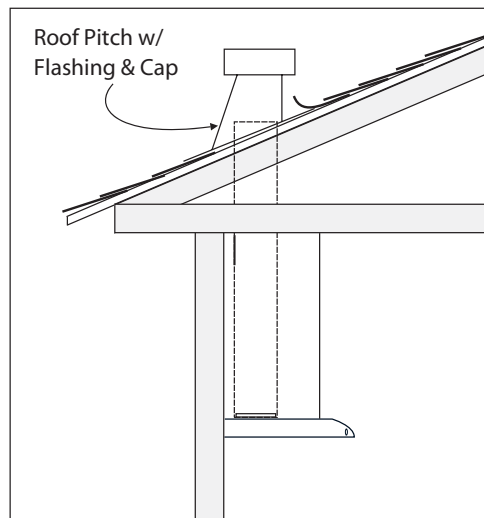
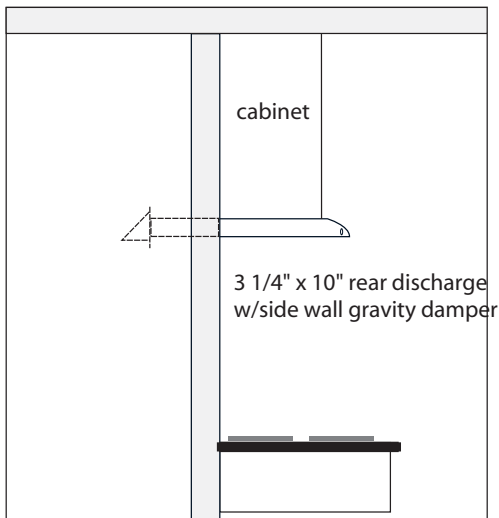
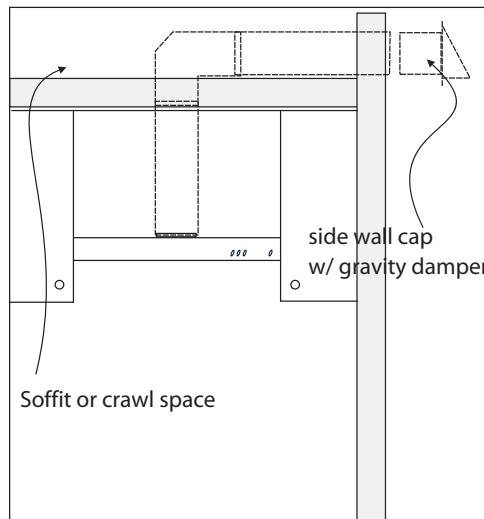
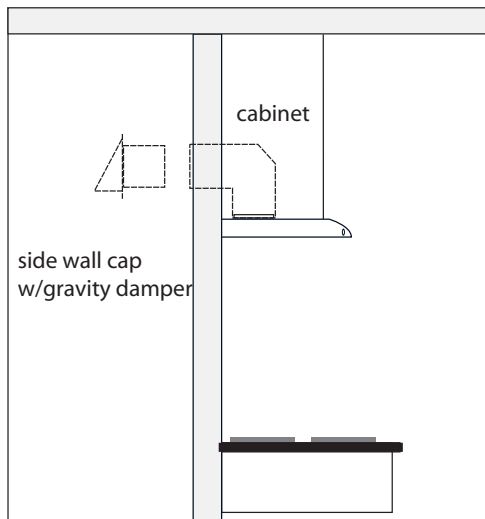



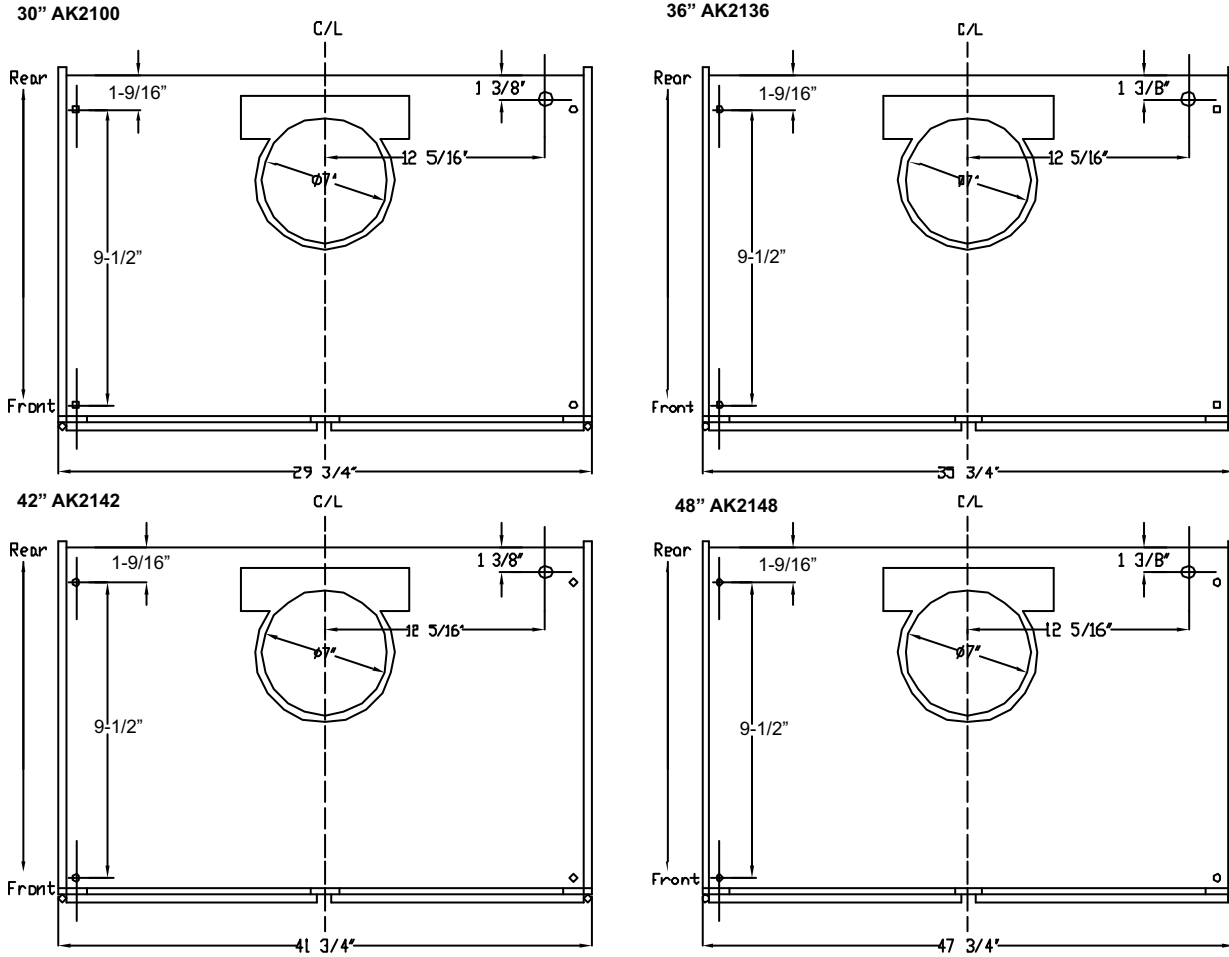

\* Dimensions for electrical knockout and mounting holes are the same for all units.

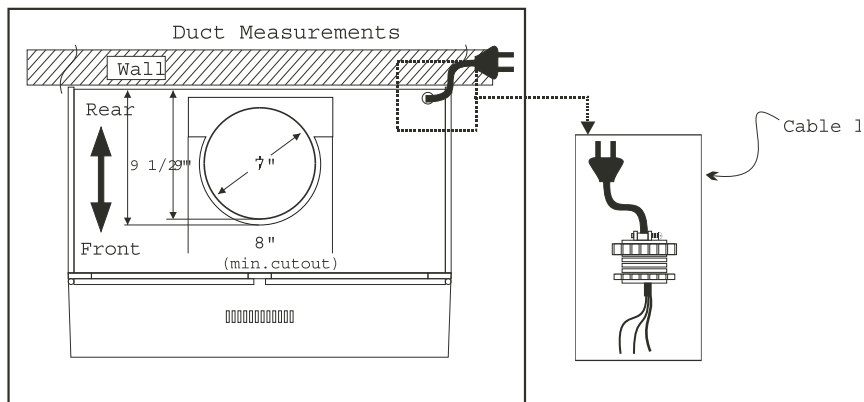

### Cable Lock:

A cable locking connector (not supplied) might also be required by local codes. Check with local requirements and codes, purchase and install appropriate connector if necessary.

# Installation - Installing the hood



1. Remove all contents from box. Unscrew and remove bottom grease splash shield.



2. Locate electrical connection box inside. Unscrew cover to reveal wiring.

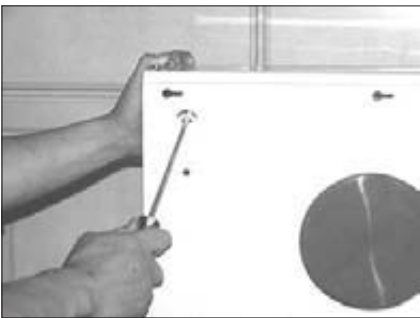

3. Locate electrical connection box knock out from left rear of hood and pry open with screwdriver.



4. Cut out cabinet base opening if necessary.



5. Reinforce cabinet base with 1x2 wood strips if additional strengthening is required. Unscrew and remove bottom grease splash shield.



6. Install damper if required by local codes (not provided), or install 6" starting collar (green).\*\*



7. Lift hood to bottom of cabinet



8. Support hood to place, fasten both rear with screws and washer provided.



9. Fasten front of hood. Level all sides and adjust accordingly.\*\*



10. Drill out cabinet base through electrical box with 3/4" boring bit.

### EZ ANCHORS

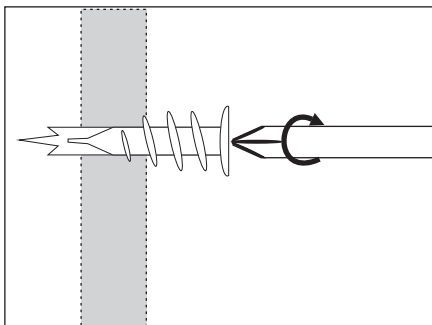

Tap EZ anchor tip into marked drywall locations, turn with screwdriver until seated flush.

Note: Whenever possible, the hood should be secured to wall studs. Use EZ anchors only on hollow drywall applications (minimum drywall thickness 1/2"). If a stud or wood surface is present, fasten anchors with screws directly into stud or plywood. For all other wall types (concrete, brick, tiles, etc), use appropriate anchors for mounting.

# Installation - Installing the hood

## ELECTRICAL CONNECTION



11. Pull electrical supply wire through drill out or use #14 grounded wire for receptacles (not supplied).



12. Connect both wires (blk) on hood to either power supply (blk or wht). Ground green wire.\*\*

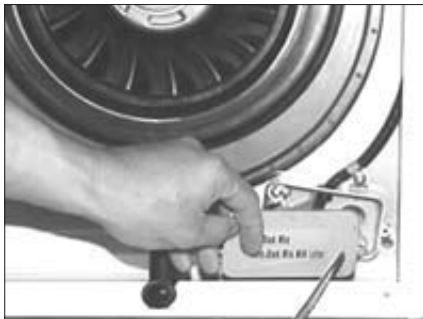

13. Reinstall electrical box cover.



14. Reinstall bottom splash shield by first fastening 3 rear screws, (do not tighten all the way).

## ELECTRICAL - WARNING

All Electrical work must be performed by qualified electrician or person with similar technical know how and background.

For personal safety, remove house fuse or open circuit breaker before beginning installation.

Do not use extension cord or adapter plug with this appliance.

Follow National electrical codes or prevailing local codes and ordinances.

### Electrical Supply:

This appliance requires a 120V 60Hz electrical supply, and connected to an individual, properly grounded branch circuit, protected by a 15 or 20 ampere circuit breaker or time delay fuse. Wiring must be 2 wire w/ ground. Please refer to Electrical Diagram labeled on product.



15. Next, fasten the 3 front screws and begin tightening all screws from rear to front.



16. Connect duct to opening, inspect and tape all joints with approved aluminum or duct tape.



17. Turn on electrical supply or plug into receptacles.

**TYPHOON AK2100, AK2136, AK2142, AK2148**

Zephyr series are equipped with the option of a 7" vertical discharge, 3 1/4"x10" vertical discharge, or 3 1/4"x10" rear discharge. Additional accessories are provided to convert to either of the above discharge methods.

Note: hood is pre configured for 7" vertical discharge.

Convertible Options

Vertical discharge	7" round
Vertical discharge	3 1/4"x10"
Horizontal rear discharge	3 1/4"x10"

Convertible Accessories

Rectangular transition adaptor
Round transition adaptor (pre-mounted)
Rectangular rear cap (pre-mounted)
3 1/4"x10" starting collar

**3 1/4"x10" Vertical Discharge**



1. Remove pre-mounted 7" transition adaptor or duct opening.



2. Place rectangular transition adaptor as shown by first installing 4 screws on half round section.



3. Mount the 3-1/4"x10" starting collar on top of transition piece with remaining screws.

## 3 1/4" x 10" Rear Discharge



1. At rear of range hood, remove all screws on premounted rear rectangular cap and remove cap with gasket.



2. Remove top premounted transition piece.



3. Remove diverter blocks through top opening.



4. Mount starting collar (provided) at rear discharge opening with gasket previously removed.



5. Mount rectangular transition piece at opening.

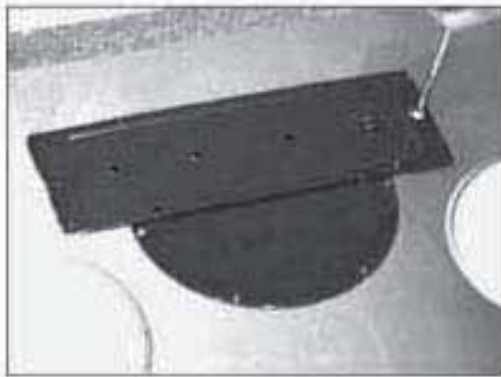

6. Mount rectangular cap (previously removed) on top of transition adaptor. Seal all open holes with duct tapes.

# Features & Controls - Touch Control Module Overview

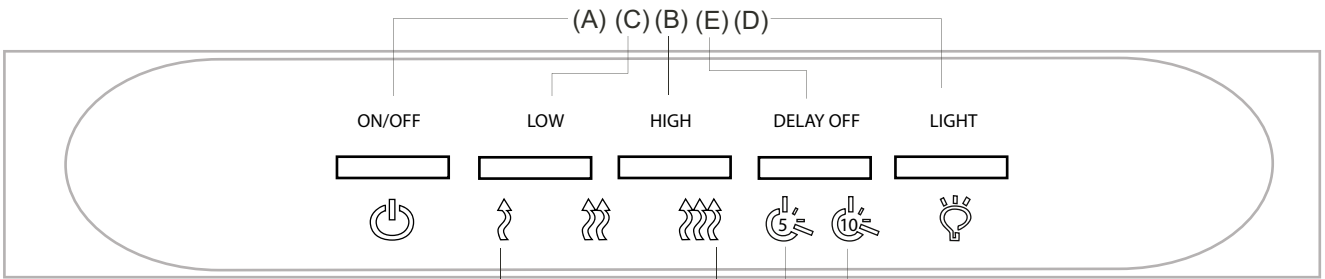

Zephyr Model AK2100, AK2136, AK2142, AK2148  
Touch Control Module

(G) Indicator: indicates level of blower speed from 1 to 6  
 Level 1(low) -Indicator 1 flashing  
 Level 2 - Indicator 1 lit  
 Level 3 - Indicator 2 flashing  
 Level 4 - Indicator 2 lit  
 Level 5 - Indicator 3 flashing  
 Level 6 (high) - Indicator 3 lit

- (A) turn hood on/ off
- (B) adjust to higher speed level (1 to 6)
- (C) adjust to lower speed level (6 to 1)
- (D) turns lights on/off and dim (night light)
- (E) shuts off hood in 5 or 10 minutes
- (F) Indicator: indicates 5, or 10 minutes delay when lit



**Blower Controls**

Turn on the blowers by pressing "on/off" once.

*press:*

on/ off

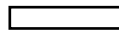

turns blowers on

Adjust level of speed (1 to 6) by pressing "high" or "low".

*press:*

low

high



adjust speed from low to high (1 to 6)

**Speed Indicator**

The speed indicator will show the speed the blowers are operating at as follow:

- Level 1(low) -Indicator 1 flashing
- Level 2 - Indicator 1 lit
- Level 3 - Indicator 2 flashing
- Level 4 - Indicator 2 lit
- Level 5 - Indicator 3 flashing
- Level 6 (high) - Indicator 3 lit

*indicator:*

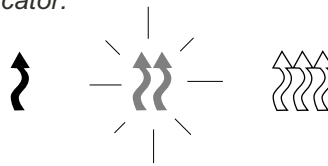

Note: The control is equipped with a speed setting memory module. When turning on the blowers, the speed level will start at the speed setting last memorized.

Turn off the blowers by pressing "on/off" again.

*press:*

on/ off

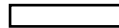

turns blowers-light off

**Lights Controls**

Turn on halogen lamps by pressing "light".

*press:*

light



turns lights on

Press 2nd time will dim to night light.



*press again:*

light



turn lights down (night light)

Press again to turn lamps off.

*press again:*

light

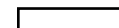

turns lights off



# Features & Controls - Controls

## Timed Delay Off

Press "delay off" once to turn all range hood operation off in 5 minutes.

Indicator "5" will be lit

*press once:*

delay off

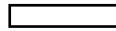

turns off in 5 minutes

*Indicator*



indicator "5" will be lit

Press "delay off" twice to turn all range hood operation off in 10 minutes.

Indicator "10" will be lit

*press twice:*

delay off

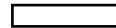

turns off in 10 minutes

*Indicator*



indicator "10" will be lit

**SELF CLEAN FEATURE**

All Zephyr model AK2100, AK2136, AK2142, AK2148 hoods are filter-less and designed with a self clean feature. The centrifugal blower system automatically liquifies cooking residue accumulated in its internal housing. All systems are equipped with dishwasher safe clean cups for its self clean function.

Cooking residue are often automatically liquified and can accumulate in the clean cups from everyday use. Nevertheless, grease from cooking could also dry and adhere in its internal housing. Running the self clean function periodically will flush out accumulated residue in the range hood's internal housing.

**CLEANING FREQUENCY**

Cleaning should be approximately once a month under normal use.

**DETERGENT**

Grease cutting detergent.

**CLEANING**

**Safety Grill**

Remove both safety grills for cleaning by simply removing Philips screws. Clean safety grills in dishwasher under normal wash cycle.

**Warning**

Use extreme caution as both safety grills are removed. Beware of blowers catching on to hair, loose clothing, and fingers. NEVER leave children unattended.

**Self Clean**

Turn both blowers on lowest speed for cleaning.

Set timed delay off to 5 minutes as indicated.



set to lowest speed:

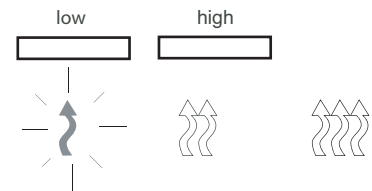

set to 5 min. delay off:

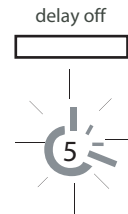

## Maintenance - Cleaning

With nozzle on "spray" squirt detergent directly onto blower blades 30 - 35 times.

Repeat with second blower. Allow self cleaning to complete in 5 minutes (if desired, spray water to rinse off detergent after completion of the cleaning cycle and run another few minutes).

Remove residue cups. Clean w/mild detergent or in dishwasher under normal wash cycle.

### Cleaning Tip:

Fill residue cups 1/4 full with water before cleaning or during regular use. This will help to prevent residue from drying and tacking on cup surface



### Surface Maintenance:

Clean periodically with hot soapy water and clean cotton cloth. Do not use corrosive or abrasive detergent , or steel wool/scouring pads which will scratch and damage surface.

For heavier soil use liquid degreaser.

After cleaning, you may use non-abrasive stainless steel polish/ cleaners, to polish and buff out the stainless luster and grain Always scrub lightly, with clean cotton cloth, and with the grain.

Do not use any product containing chlorine bleach. Do not use "orange" cleaners.

## REPLACING LIGHT BULBS

**CAUTION:** Light bulb becomes extremely hot when turned on. DO NOT touch bulb until switched off and cooled. Touching hot bulbs could cause serious burns.

Light bulbs (included) are 35W halogen GU-10.

Remove by turning light bulb counter clockwise. Use a suction cup or rubber latex glove if removing the bulb is difficult.

1. Upon completion of installation nothing works.	Check if unit has been plugged in, make sure that all power has been turned back on and all electrical wiring are properly connected.
2. Light is on but blowers are not turning at all or seems to be scraping on something.	Blower blade unit might have been mounted too low and scraping the bottom or jammed. Loosen hex screw on blade unit and adjust to proper height.
3. When blowers are on, something seems to be loose and spinning around inside.	There might have been foreign particles left within the discharge opening or rocks, leaves, branches, etc. that might have fell in from old duct work. Disconnect duct work to inspect and remove any foreign particles.
4. Vibration when blowers are on	Unit might not have been secured properly on cabinet. Or cabinet might need to be further secured into studs on wall.
5. Blowers noise	Our blowers are designed to perform up to 850 cfm. A properly functioning motor itself should be relatively quiet. Nevertheless, due to vacuum created by the suction, noise level up to 6 sones will be generated when both blower unit is turned on at its maximum speed. Employing low speeds will suffice moderate cooking such as steaming, broiling etc.
6. Light is not working	Light bulb might need to be replaced. On some instances, the fragile bulb could have been damaged during the shipping process. Replace light bulb.
7. No grease is collected in the clean cups	Grease flow will vary by the amount, methods and types of cooking. If pan-frying is frequent accompanied by steaming, vapor from steam will liquefy accumulated grease in its internal housing and flows in the clean cups. No grease collected in the residue containers is normal until the self clean function is completed. Clean blowers approximately once a month as instructed to avoid clogging.
8. No grease is collected in the residue containers after self cleaning.	Tubes connected to the internal housing might have been clogged due to lack of cleaning. Or hood might not have been leveled when installed. Unclog tubes or re-install hood.
9. Safety grill are dirty	The self clean feature cleans only the internal housing within the range hood. Remove safety grill to clean in dishwasher and clean all surface periodically as instructed.
10. Blowers seemed weak	Check duct size used, duct size should be at least 7". Range hood WILL NOT function properly with the insufficient duct size. Check if duct is clogged or if damper unit is not opening properly. A tight mesh on a side wall cap unit might also cause restriction to the air flow. Use a damper type sidewall cap. Reduce the number of elbows and length of duct work or increase duct size. Check if all joints are properly connected, sealed and taped.
11. Cooking fumes and smoke dissipates before it reaches the blower.	Check if unit is installed at the recommended height. The range hood should also be able to cover the entire cooking area from left to right and most areas from rear to front. Open doors and windows might also distract air flow before it reaches the blowers. Make sure blowers are on high speed for heavy cooking.

# Warranty

**TO OBTAIN SERVICE UNDER WARRANTY:**

or any Service Related Questions, please call:  
**1-888-880-8368**

**Staple your receipt here.  
Proof of the original purchase  
date is needed to obtain service  
under the warranty.**

**TO OBTAIN SERVICE UNDER WARRANTY:** You must present proof of original purchase date.

Please keep a copy of your dated proof of purchase (sales slip) in order to obtain service under warranty.

**One Year Service Repair Warranty:**

For one year from date of original purchase, we will provide free of charge, service labor to repair any failed parts or components due to manufacturing defects.

**Ten Years Parts Warranty:**

For ten years from date of original purchase, we will provide free of charge, nonconsumable replacement parts or components that failed due to manufacturing defects. Consumable parts not covered by this warranty include: Light Bulbs, Metal and Carbon Filters.

**Who is Covered:**

This warranty is extended to the original purchaser for products purchased for ordinary home use in the 48 mainland states, Hawaii and Washington D.C. **In Canada and Alaska, this warranty is Limited.** There might be costs associated with shipping the products to our designated service locations or you might need to pay service technician's travel costs, to have the appliance repaired in-home.

**This Warranty will be Voided when:**

Product damaged through negligence, misuse, abuse, accident. Improper installation and failure to follow installation instructions. When product is used commercially or other than its intended purpose. Damaged because of improper connection with equipment of other manufacturers. Repaired or modified by anyone other than Zephyr's Authorized Agents.

**What is Not Covered:**

Consumable parts such as light bulbs, filters, and fuses. Services outside of service area and the labor cost incurred in connection with the removal, shipping and reinstallation cost, nor does it cover any other contingent expenses. The natural wear of finish, and wear due to improper maintenance, use of corrosive and abrasive cleaning products, pads, and oven cleaner products. Chips, dents or cracks due to abuse, misuse, freight damage, or improper installation. Service trips to your home to teach you how to use the product. Damage of product caused by accident, fire, floods or act of God.

This warranty is valid in the United States and Canada. It is non-transferable and applies only to the original purchaser and does not extend to subsequent owners of this product. Any applicable implied warranties, including the warranty of merchantability, are limited in duration to a period of express warranty as provided herein beginning with the date of original purchase at retail and, no warranties, whether express or implied, shall apply to this product thereafter.

Have your product proof of purchase with date ready for warranty issues.  
Or write to:

**Zephyr Corporation  
Service and Warranty Department  
395 Mendell Street  
San Francisco, CA 94124**

Description	Part#
Light Bulb (GU-10)	Z0B-0015S
Telescopic Back Splash 30" SS	AK0710
Telescopic Back Splash 36" SS	AK0716
Telescopic Back Splash 42" SS	AK0712
Telescopic Back Splash 48" SS	AK0718

To order parts, visit us online at : [www.zephyronline.com](http://www.zephyronline.com) and go to the parts store.  
Or call us at : 888-880-8368

# Exploded View Diagram

**Typhoon**  
AK21xxX

19 - Hardware Packet

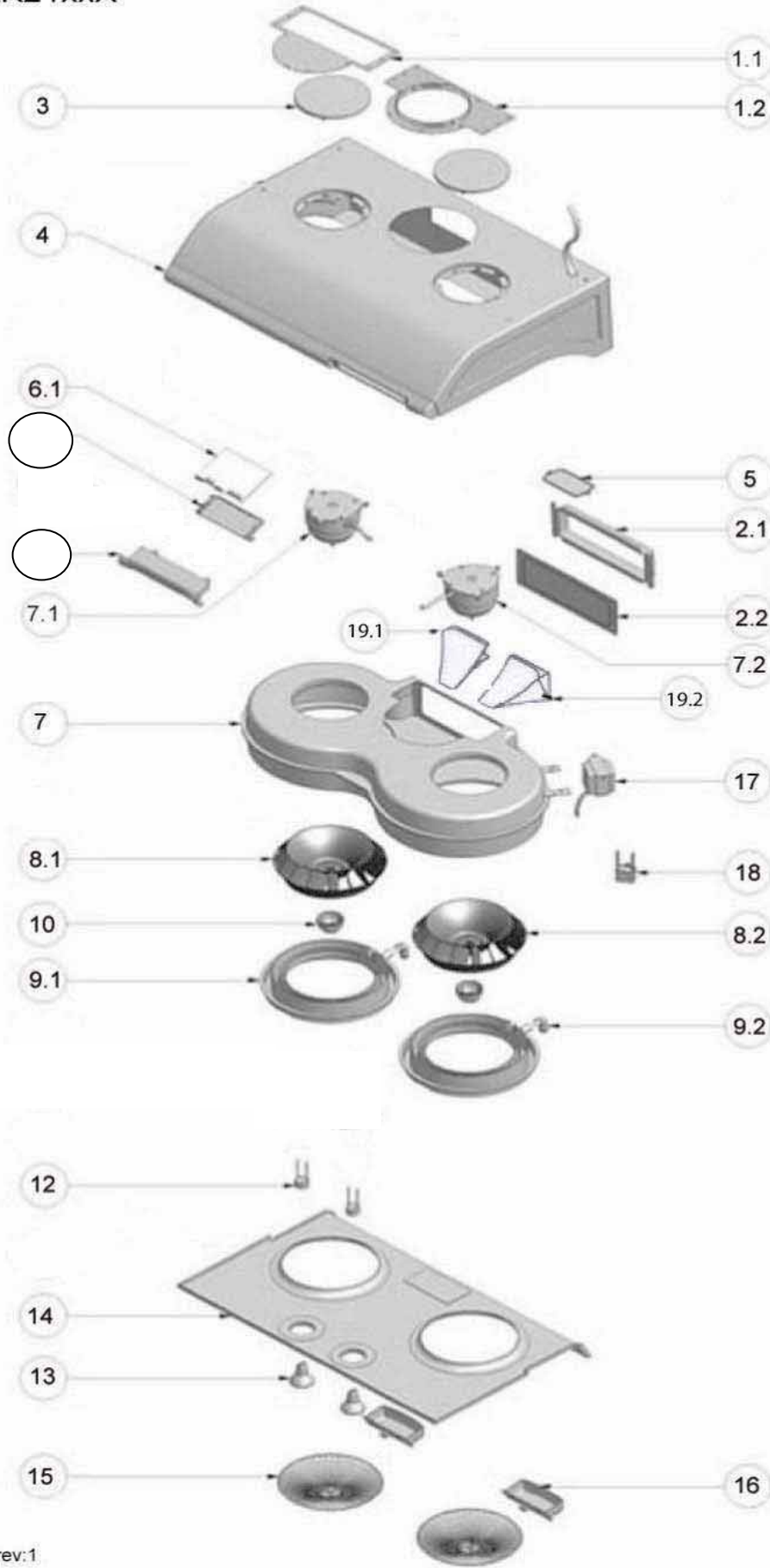

0705 rev:1





# Exploded View Diagram

9.1	KCC139-10000	Residue Pan
9.2	KCD070-10000	Residue Tube

# ZEPHYR

## Limited Warranty

**STAPLE YOUR RECEIPT HERE**  
**Proof of the original purchase**  
**date is needed to obtain**  
**service under warranty**

**TO OBTAIN SERVICE UNDER WARRANTY OR FOR ANY SERVICE RELATED QUESTIONS, please call:**  
**1-888-880-8368**

Zephyr Corporation (referred to herein as “we” or “us”) warrants to the original consumer purchaser (referred to herein as “you” or “your”) of Zephyr products (the “Products”) that such Products will be free from defects in materials or workmanship as follows:

**Ten Year Limited Warranty for Parts:** For ten years from the date of your original purchase of the Products, we will provide, free of charge, Products or parts to replace those that failed due to manufacturing defects. We may choose, in our sole discretion, to repair or replace parts before we elect to replace the Products.

**One Year Limited Warranty for Labor:** For one year from the date of your original purchase of the Products, we will provide, free of charge, the labor cost associated with repairing the Products or parts to replace those that failed due to manufacturing defects. After the first year from the date of your original purchase, you are responsible for all labor costs associated with this warranty.

**Warranty Exclusions:** This warranty covers only repair or replacement, at our option, of defective Products or parts and does not cover any other costs related to the Products including but not limited to: (a) normal maintenance and service required for the Products and consumable parts such as light bulbs, metal and carbon filters and fuses; (b) any Products or parts which have been subject to freight damage, misuse, negligence, accident, faulty installation or installation contrary to recommended installation instructions, improper maintenance or repair (other than by us); (c) commercial use of the Products or use otherwise inconsistent with its intended purpose; (d) natural wear of the finish of the Products or wear caused by improper maintenance, use of corrosive and abrasive cleaning products, pads, and oven cleaner products; (e) chips, dents or cracks caused by abuse or misuse of the Products; (f) service trips to your home to teach you how to use the Products; or (g) damage to the Products caused by accident, fire, floods or act of God. If you are outside our service area, additional charges may apply for shipping costs for warranty repair at our designated service locations and for the travel cost to have a service technician come to your home to repair, remove or reinstall the Products. After the first year from the date of your original purchase, you are also responsible for all labor costs associated with this warranty.

**Limitations of Warranty. OUR OBLIGATION TO REPAIR OR REPLACE, AT OUR OPTION, SHALL BE YOUR SOLE AND EXCLUSIVE REMEDY UNDER THIS WARRANTY. WE SHALL NOT BE LIABLE FOR INCIDENTAL, CONSEQUENTIAL OR SPECIAL DAMAGES ARISING OUT OF OR IN CONNECTION WITH THE USE OR PERFORMANCE OF THE PRODUCTS. THE EXPRESS WARRANTIES IN THE PRECEDING SECTION ARE EXCLUSIVE AND IN LIEU OF ALL OTHER EXPRESS WARRANTIES. WE HEREBY DISCLAIM AND EXCLUDE ALL OTHER EXPRESS WARRANTIES FOR THE PRODUCTS, AND DISCLAIM AND EXCLUDE ALL WARRANTIES IMPLIED BY LAW, INCLUDING THOSE OF MERCHANTABILITY AND FITNESS FOR A PARTICULAR PURPOSE.** Some states or provinces do not allow limitations on the duration of an implied warranty or the exclusion or limitation of incidental or consequential damages, so the above limitations or exclusions may not apply to you. To the extent that applicable law prohibits the exclusion of implied warranties, the duration of any applicable implied warranty is limited to the same ten-year period described above. Any oral or written description of the Products is for the sole purpose of identifying the Products and shall not be construed as an express warranty. Prior to using, implementing or permitting use of the Products, you shall determine the suitability of the Products for the intended use, and you shall assume all risk and liability whatsoever in connection with such determination. We reserve the right to use functionally equivalent refurbished or reconditioned parts or Products as warranty replacements or as part of warranty service. This warranty is not transferable from the original purchaser and applies in the United States and Canada.

**To Obtain Service Under Limited Warranty:** To qualify for warranty service, you must: (a) notify us at the address or telephone number stated below within 60 days of the discovery of the defect; (b) give the model number and part identification number and serial number; and (c) describe the nature of any defect in the Product or part. At the time of the request for warranty service, you must present evidence of your proof of purchase and proof of the original purchase date. If we determine that the warranty exclusions listed above apply or if you fail to provide the necessary documentation to obtain service, you will be responsible for all shipping, travel, labor and other costs related to the services.

**Zephyr Corporation, Service Department, 395 Mendell Street, San Francisco, CA 94124 1-888-880-8368**

## Free Manuals Download Website

<http://myh66.com>

<http://usermanuals.us>

<http://www.somanuals.com>

<http://www.4manuals.cc>

<http://www.manual-lib.com>

<http://www.404manual.com>

<http://www.luxmanual.com>

<http://aubethermostatmanual.com>

Golf course search by state

<http://golfingnear.com>

Email search by domain

<http://emailbydomain.com>

Auto manuals search

<http://auto.somanuals.com>

TV manuals search

<http://tv.somanuals.com>