

Know-how

New product information from Zetex

July 2004

ZXLD1615/1601 boost converter for LCD-OLED bias and DC-DC supply



Features

- Internal 30V NMOS switch
- True analog output voltage control
- High efficiency: 80% typical
- 2.5V to 5.5V supply range
- Low quiescent current
- TSOP23-5 and SC70-6 packages
- ZXLD1615 is pin compatible to LT1615

Benefits

- Minimum external components
- Reduced flicker
- Longer battery life
- Compatible with Li-Ion battery
- Longer battery life
- Minimum board area
- Alternate source to LT1615

Applications

- LCD and OLED biasing
- Cell phones
- Varactor diode biasing
- Digital cameras
- DC-DC boost converter
- PDAs

Functional Description

The ZXLD1615 and ZXLD1601 are PFM inductive DC-DC boost converters. They are particularly suited to provide bias voltages for LCD and OLED displays. Up to 28V can be generated from an input voltage between 2.5 and 5.5V.

The switch is integrated on chip together with the peak current sense resistor. An output current of 10mA is available at 28V, with proportionally higher currents at lower voltages.

The output voltage is set by 2 external resistors connected to the feedback input. PWM control at the enable input can be used to adjust this voltage. An on chip filter enables flicker free control at PWM frequencies above 10kHz, or normal gated control below 1kHz.

Quiescent current is typically 60 μ A. At shutdown the maximum current is 100nA.

The ZXLD1615ET5 is packaged in a low profile TSOT23-5 package. Maximum package height is 1mm. The ZXLD1601 is packaged in a small footprint SC70-6 package.

The ZXLD1615ET5 is pin compatible with LT1615, TPS61040 and SP6690. In many applications the ZXLD1615 can replace these parts. Input voltage range is the main difference. Most other parameters are the same or very close.

Description	V _{in} (V)	Output voltage	Typical quiescent current (μ A)	Shutdown current (nA)	Efficiency %	Switching frequency (kHz)	Package
ZXLD1615ET5	2.5 to 5.5	Up to 28V	60	100	80	600	TSOT23-5
ZXLD1601H6	2.5 to 5.5	Up to 28V	60	100	80	600	SC70-6

Applications Information

The data sheets contain information about the operation of each converter and how the internal blocks function. The data sheets also contains additional applications information on:

- 1cell Li-Ion to 3.3V SEPIC converter
- 1cell Li-Ion to 5V SEPIC converter
- Triple output boost converter for LCD or OLED bias
- Selecting inductors, capacitors and diodes.

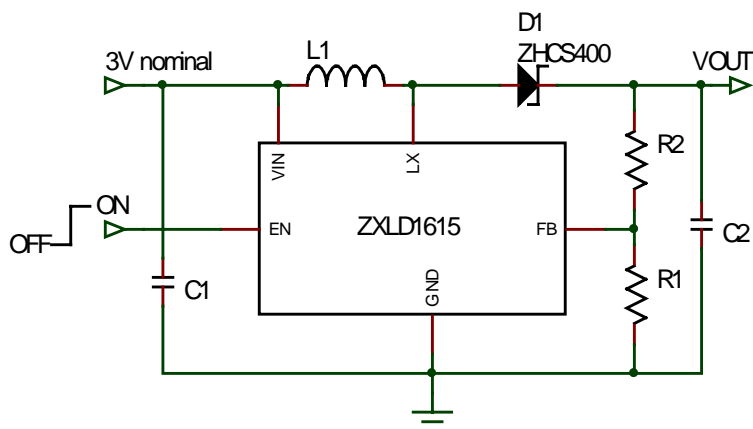

Competition

There are several competitive solutions available for LCD and OLED biasing. Zetex has chosen to make a SOT23-5 pin compatible version of the industry leading LT1615. This should enable an easy acceptance of the part and a high chance of being considered as an alternative source.

Other SOT23-5 pin compatible parts are:

Sipex – SP6690

TI – TPS61040

The main performance attributes of the ZXLD1615 compared with competition are shown in the table.

The ZXLD1601H6 is one of the smallest packages available for this function. This will be of interest where space is a premium.

Other parts which are similar but not pin compatible are:

Maxim – MAX1605 in SOT23-6

Micrel – MIC2141

Zetex is price competitive with respect to all these suppliers.

Company	Zetex	Linear Tech	Texas Inst	Sipex
Part number	ZXLD1615	LT1615	TPS61040	SP6690
Conversion mode	PFM	PFM	PFM	PFM
Supply input voltage (V)	2.5 to 5.5	1.2 to 15	1.8 to 6	1 to 15
Output voltage (V)	28	34	28	30
Switch current (mA)	320 typ	350 typ	400 typ	350 typ
Quiescent current (μ A)	60 typ	20 typ	28 typ	20 typ
Standby current (μ A)	0.1 max	1 max	1 max	1 max
Feedback ctrl voltage (V)	1.0 \pm 2%	1.23 \pm 2%	1.233 \pm 2%	1.22 \pm 4%
Efficiency at 3V (%)	80	80	80	80
Operating temperature ($^{\circ}$ C)	-40 to +85	-40 to +85	-40 to +85	-40 to +85

Potential customers to look for

- LCD or OLED module manufacturers where a complete display system is provided to end users. (This is also an opportunity for the ZXLD1937 when backlighting is included in the module.)
- Manufacturers of handheld equipment incorporating color LCD or OLEDs where bias is generated externally to the display module. This typically includes digital cameras, mobile phones, PDAs, GPS and portable test equipment.
- Users of LT1615 where the supply voltage range is within 2.5 to 5.5V.

Typical applications include:

- LCD bias generator
- OLED bias generator
- Varactor diode bias generator
- DC-DC boost for hand held instruments
- PIN diode bias generator

Pricing

As a guide :

ZXLD1615ET5TA is \$0.53 at 1k and \$0.41 at 10k.

ZXLD1601H6TA is \$0.65 at 1k and \$0.50 at 10k

As always with all new products please ask if you have any pricing questions.

Ordering Information

- #ZXLD1615ET5TA – samples available now
- #ZXLD1601H6TA – samples available now
- ZXLD1615ET5TA – production available now
- ZXLD1601H6TA – production available now

**Do you have a key customer
you'd like to send samples to?**

Contact us at:

europa.sales@zetex.com

asia.sales@zetex.com

usa.sales@zetex.com

For lead free product prefix the part number with U.

i.e. UZXLD1615ET5TA

This convention will apply until Zetex is completely lead free, at which time the U prefix will not be required.

TA reels contain 3000 parts. Where larger reels are required the TC reel contains 10,000 parts.

Support

- Datasheets - the ZXLD1615 and ZXLD1601 datasheets are available now on the Zetex web site:
- Application note – Several applications are described in the product datasheets. Future application notes will be publicized as they become available
- Evaluation board for ZXLD1615 available for qualified customers.

Conclusion

As with many Zetex products, what we show on our collateral is not the limit of what we can achieve. If you see other product opportunities, please let us know. Your local Zetex office will be pleased to offer any technical support, pricing and sample requests.



Europe

Zetex GmbH
Streitfeldstraße 19
81673 München
Germany

Tel: (49) 89 45 49 49 0
Fax: (49) 89 45 49 49 49
europe.sales@zetex.com

Americas

Zetex Inc
700 Veterans Memorial Hwy
Hauppauge
NY 11788
USA

Tel: 631 360 2222
Fax: 631 360 8222
usa.sales@zetex.com

Asia Pacific

Zetex (Asia) Ltd
3701-04 Metroplaza Tower 1
Hing Fong Road
Kwai Fong
Hong Kong

Tel: (852) 26100 611
Fax: (852) 24250 494
asia.sales@zetex.com

Corporate HQ

Zetex Semiconductors plc
Lansdowne Road
Chadderton
Oldham, OL9 9TY
United Kingdom

44 161 622 4444
44 161 622 4446
hq@zetex.com

Free Manuals Download Website

<http://myh66.com>

<http://usermanuals.us>

<http://www.somanuals.com>

<http://www.4manuals.cc>

<http://www.manual-lib.com>

<http://www.404manual.com>

<http://www.luxmanual.com>

<http://aubethermostatmanual.com>

Golf course search by state

<http://golfingnear.com>

Email search by domain

<http://emailbydomain.com>

Auto manuals search

<http://auto.somanuals.com>

TV manuals search

<http://tv.somanuals.com>