

808002020304001

***Electronically-Tuned
AM/FM/MPX Radio
With CD Player***

Model VR202

Size:210 x 148
10dec02

808002020304001

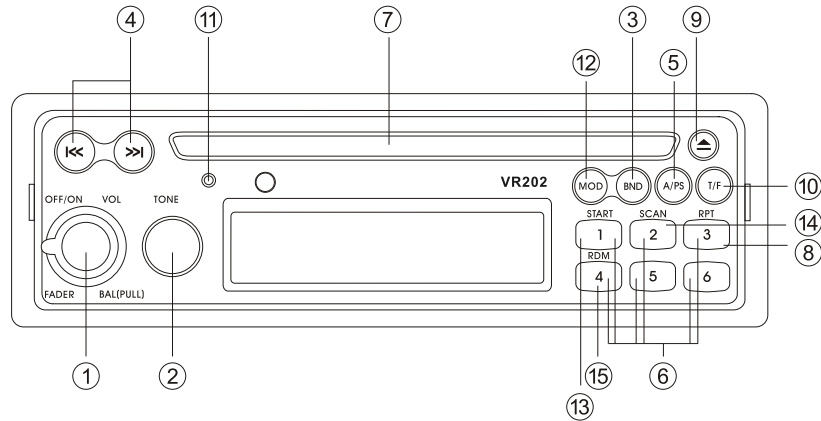

- ① **ON-OFF SWITCH/VOLUME CONTROL**
Rotate this knob clockwise to turn the radio on. Continue rotation until the desired volume level is obtained.
LEFT/RIGHT BALANCE CONTROL (PULL)
Pull the volume knob outward until it locks into the outer position. Rotate it to the left or right to obtain the desired balance between left and right speakers. Push the knob back in to return it to the volume control position.
FRONT/REAR FADER CONTROL
Rotate the outer knob to the left or right to obtain the desired balance between front and rear speakers in 4 speaker installations. When used in conjunction with the Left/Right Balance Control, you have full 4-way stereobalance capability.
- ② **TONE CONTROL**
To adjust this Knob for tone balance.
- ③ **TUNER (AM/FM BAND) SELECTOR**
During radio play, each time the BND button is pressed, the radio band changes. The indications FM1, FM2 and FM3, AM1, AM2 will appear on the display panel according to your selection. During FM operation, when the station is broadcasting in stereo, the stereo icon appears on the display. During AM operation, no indications are displayed. During CD play or AUX mode, pressing this button will change to radio operation without ejecting the disc.
- ④ **MANUAL UP/DOWN TUNING, STATION SEEK AND TRACK SELECTION**
Each time the Up Tuning side of the button is pressed, the radio will tune one frequency step higher. Similarly, each press of the Down Tuning side of the button will tune one frequency step lower. To manually tune in a station, press the appropriate directional side of the button until the desired frequency is reached. Pressing and holding either side of the button for longer than 2 seconds will cause the radio to continue tuning rapidly in the selected direction until the button is released, at which point it will seek the next available station and stop. During CD play operation, momentarily pressing and releasing either side of the button will increase or decrease CD track selection in sequence. Pressing and holding either side of the button for longer than 2 seconds, will begin fast forward or reverse play of the current track.

Size: 210 x 148
10dec02

808002020304001

- ⑤ **AUTO-STORE TUNING (AS) PRE-SET SCAN TUNING (PS)**
Press the A/PS button momentarily to scan the 6 stations in the pre-set memories of the band in use. The unit will stop at each pre-set station for 5 seconds before continuing to the next pre-set station (the channel number on the display panel will flash during Pre-Set Scan operation). Press the button again momentarily to stop Pre-Set Scan operation and remain on the selected station.
Pressing the button for longer than 2 seconds will activate the Auto-Store Tuning feature. The radio will automatically scan the band in use and enter strong stations into the pre-set memory positions for that band. If you have already set the pre-set memories of that band to your favorite stations, activating the Auto-Store Tuning feature will erase those stations and enter the new strong stations. This feature is most useful when traveling in a new area where you are not familiar with the local stations.
- ⑥ **STATION PRE-SET MEMORIES**
To set any of the 6 pre-set memory buttons, use the following procedure:
1. Turn the unit on and select the desired band.
2. Select the first station to be pre-set using the Manual Up/Down Seek Tuning functions.
3. Press the pre-set button to be set and continue to hold in until the pre-set number appears in the display panel. The station is now set into the memory of that pre-set button and can be re-called at anytime by momentarily pressing that button.
4. Repeat the above procedure for the remaining 5 pre-sets on the band in use and for the other 4 bands of the unit.
- ⑦ **CD DISC SLOT**
With the label surface facing up, gently insert the disc into the slot until the soft-loading mechanism engages and disc play begins. The CD IN indication and track number will appear on the display panel.
- ⑧ **TRACK REPEAT PLAY SELECTOR (RPT)**
During disc play, press this button to repeat the play of the selected track (RPT will appear on the display panel). Play of the track will continue to repeat until the button is pressed again and the RPT indication disappears from the display panel.
- ⑨ **DISC EJECT**
Disc play is stopped; the disc is ejected. The unit will then change to radio operation. If the disc is not removed from the unit within 10 seconds of being ejected, it will be automatically re-loaded into the unit to prevent damage to the CD. (CD IN will appear steady on the display panel).
- ⑩ **TIME/FREQUENCY DISPLAY SELECTOR (T/F)**
A momentary press of the T/F button will display the time of the incorporated quartz clock. The time display will persist for approximately 5 seconds, after which the frequency display will automatically return, unless the button is pressed again prior to the 5-second time-out.
- ⑪ **RESET BUTTON**
A RESET button is located on the front of the chassis. The re-set circuitry is provided to protect the microprocessor circuitry and should only be activated under the following circumstance:
If there is a malfunction of and of the switches on the unit or the CD player, pressing the RESET button may clear the system and return to normal operation.
- ⑫ **MOD (MODE) BUTTON**
Press this button to cycle from Radio-CD-Aux-Radio.
- ⑬ **START BUTTON**
Pressing this button during CD play will set the unit to play from beginning of track 1.

Size: 210 x 148
10dec02

808002020304001

⑭ SCAN BUTTON

To "Intro" each song on the disc for 10 seconds, press the "INTRO" button. INT will appear in the display area. To turn off this feature, press the "Intro" button again. The indicator in the display will be off.

⑮ RDM BUTTON

To play the songs on the disc in a random order (other than the original recorded order), press the "RANDOM" button. To turn off this feature, press the "RANDOM" button again. The indicator RDM in the display will be off.

SETTING THE CLOCK

1. Switch the vehicle ignition on and turn on the radio.
2. Press and hold the T/F button.
3. Press the Down Tuning button to adjust the hours and the AM/PM indication, and the Up Tuning button to adjust the minutes to the correct time.
4. When the correct time is shown on the display panel, release the T/F button and the time is displayed steadily; then wait 5 seconds for the display to return to the normal indication.

Size: 210 x 148
10dec02

808002020304001

WIRING DIAGRAM

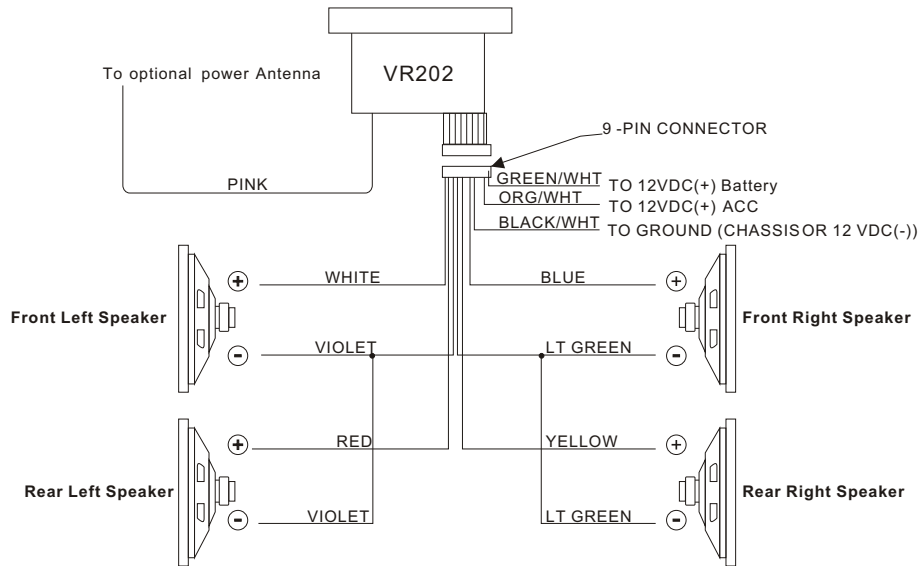

SPECIFICATIONS

Size:	7"(W) x 2" (H) x 6 1/8"(D) 178mm x 50mm x 156mm
Operating Voltage:	12VDC, Negative Ground
Output Power:	50 Watts Max. Stereo Power
Output Wiring:	Floating Ground type designed for 4 speaker use May also be used with 2 speaker.
Output Impedance:	Compatible with 4 or 8 ohm speaker.
Tuning Range:	(AM) 530-1710KHz (FM) 87.5-107.9MHz
Sensitivity:	(AM) less than 25uV (FM) less than 5uV
FM Stereo Separation:	More than 23 dB
Frequency Response:	50-10000Hz
Maximum allowable Mounting angle:	Front to back -10° - +30° Side to Side -10° - +10°

Size:210 x 148
10dec02

808002020304001

AM AND FM RECEPTION IN A MOBILE ENVIRONMENT

Although you may be familiar with both AM and FM reception in your home. you will experience notable differences in reception while driving your car . This page will explain why these variances occur and how they affect the broadcast you are listening to .

Both AM and FM provide excellent listening enjoyment and supply the diversified entertainment necessary to relieve the boredom of hours "behind the wheel" of you car FM reception although unique in its characteristics while driving, provides a totally new sound experience unlike AM reception. The clarity of tone, the richness of sound and the varied program content provide hours of uninterrupted listening enjoyment. The few reception inconveniences common to FM are compensated by the many plus features of a sound experience rivaled only by a live sound performance

Your new AM-FM radio or radio-tape system has been built to the strictest engineering standards available today and through quality components and construction will provide maximum performance under all conditions . A few minutes reading this page will enable you to obtain the most from FM reception and provide answers to your questions about the differences between AM and FM operation while driving in your car

Some facts about AM and FM reception:

1 RECEPTION IN TUNNELS

Although you will lose AM reception when driving through tunnels and under large bridges, it is common to continue to receive FM reception.

2 THE NUMBER OF STATIONS IN YOUR AREA

Depending upon your location you will usually find the number of AM stations in your area outnumber the number FM stations, although the continuing popularity of FM reception has significantly increased the number of FM stations nationwide.

3. RECEPTION DURING STORMS

Local electrical thunderstorm activity often produces sharp static sound when listening to AM stations although you will find that FM is unaffected

4. ELECTRICAL INTERFERENCE

When listening to AM stations, you may experience some buzzing sounds or static when passing electrical roadside power lines. Which does not interfere with FM reception, Conversely, FM may be affected by electrical noise from passing cars or trucks while AM reception is not.

5. FM RECEPTION RANGE

FM reception range is usually limited to 50 miles from the broadcast station. FM signals radiate straight out from the broadcast antenna. They do not follow the earth's curve and are not reflected back to earth by the atmosphere resulting in limited "line of sight" reception range

6. AM RECEPTION RANGE

AM stations can be received several hundred miles from the broadcast station. AM signals follow the earth's curve and are easily reflected back to earth by the atmosphere. Therefore , an AM signal is easily received far from the broadcast station antenna.

FM RECEPTION WHILE YOU ARE DRIVING

Since FM signals become weaker the further you drive away from the broadcast station you will experience flutter, noisy reception and fading in the poor signal fringe area Through the modern circuitry in this radio, this "Fringe Area" has been greatly reduced for greater reception area. Even with this improved circuitry eventually the FM signal will become too weak to provide quality reception . When this occurs it is best to change to a stronger. Local FM station

Although FM signals are not reflected by the atmosphere they are easily reflected by solid objects. This effect of FM signals provides two totally different reception possibilities. First an FM signal can "bounce" between tall buildings resulting in unexpected reception in many areas.

Size:210 x 148
10dec02

808002020304001

The same effect can result in the "loss" of an FM signal if a large obstruction is located between you and the FM antenna. If hills or buildings between you and the antenna block the signals. It is possible to find reception very poor even when you are not far from the FM antenna



The Mobile Electronics Company

AUDIOVOX *S***SPECIALIZED** **A****APPLICATIONS, L.L.C.**

For a list of electronics products specifically designed for
The mobile environment, please visit us on the web
at: www.asaelectronics.com.

Made in China

Size:210 x 148
10dec02

90 DAY/12 MONTH LIMITED WARRANTY

AUDIOVOX SPECIALIZED APPLICATION, LLC (the company) warrants to the original retail purchaser of this product that should this product or any part thereof, under normal use and conditions, be proven defective in material or workmanship within 90 days from the date of original purchase, such defect(s) will be repaired or replaced (at the company's option) without charge for parts and repair labor. After the initial 90 day period and for a period of 12 months from the date of original purchase, the Company will supply at no charge a replacement for any defective part(s), but will charge for the labor to repair the product.

To obtain repair or replacement within the terms of this warranty, the product is to be delivered with proof of warranty coverage (e.g.: dated bill of sale), specification of defect(s), transportation prepaid, to an approved warranty station, or the Company at the address shown below.

This warranty does not extend to the elimination of externally generated static or noise, to the correction of antenna problems, to costs incurred for removal or reinstallation of the product, or to damage to any tapes, speakers, accessories, or electrical systems.

This warranty does not apply to any product or part thereof which, in the opinion of the company, has been damaged through alteration, improper installation, mishandling, misuse, neglect, or accident. THE EXTENT OF THE COMPANY'S LIABILITY UNDER THIS WARRANTY IS LIMITED TO THE REPAIR OR REPLACEMENT PROVIDED ABOVE, AND, IN NO EVENT, SHALL THE COMPANY'S LIABILITY EXCEED THE PURCHASE PRICE PAID BY THE PURCHASER FOR THE PRODUCT.

This warranty is in lieu of all other express warranties or liabilities. ANY IMPLIED WARRANTIES, INCLUDING ANY IMPLIED WARRANTY OF MERCHANTABILITY, SHALL BE LIMITED TO THE DURATION OF THIS WARRANTY. ANY ACTION FOR BREACH OF ANY WARRANTY HEREUNDER INCLUDING ANY IMPLIED WARRANTY OF MERCHANTABILITY MUST BE BROUGHT WITHIN A PERIOD OF 30 DAYS FROM THE DATE OF ORIGINAL PURCHASE. IN NO CASE SHALL THE COMPANY BE LIABLE FOR ANY CONSEQUENTIAL OR INCIDENTAL DAMAGES FOR BREACH OF THIS OR ANY OTHER WARRANTY, EXPRESS OR IMPLIED, WHATSOEVER. No person or representative is authorized to assume for the company any liability other than expressed herein in connection with the sale of this product.

Free Manuals Download Website

<http://myh66.com>

<http://usermanuals.us>

<http://www.somanuals.com>

<http://www.4manuals.cc>

<http://www.manual-lib.com>

<http://www.404manual.com>

<http://www.luxmanual.com>

<http://aubethermostatmanual.com>

Golf course search by state

<http://golfingnear.com>

Email search by domain

<http://emailbydomain.com>

Auto manuals search

<http://auto.somanuals.com>

TV manuals search

<http://tv.somanuals.com>