

AUDIOVOX®

CCS-203

CRUISE CONTROL MAGNET KIT INSTALLATION MANUAL

MAGNET AND SPEED SENSOR INSTALLATION (OPTIONAL)

The magnets, along with the speed sensor provide distance pulses to the cruise control. When the drive shaft spins, the magnets attached to it move by the speed sensor coil. This generates electrical pulses which are counted by the cruise control.

MAGNET LOCATION:

Rear wheel drive vehicles: Magnet location is not to exceed 12 inches (30 cm) from the front (transmission end) universal joint, or damage may result from the side-to-side, or up and down movement of the drive shaft. See Figure 7.1.

If this is not possible the magnets can be mounted on the drive shaft not more than 12 inches (30 cm) from the rear universal joint. If this location is chosen, the Speedsensor bracket must be connected to a bolt on the differential. Be sure the magnet location is within reach of the bracket and sensor. See Figure 7.2.

Front wheel drive vehicles: Select either the right or left hub near the transmission housing. Select the hub with the best accessibility and insure there is adequate clearance for the magnets. See figures 7.7 and 7.8.

NOTICE: *It is important to keep the magnets as close as possible to the stationary universal joint, but at the same time, keep magnets away from the catalytic converter and exhaust pipe.*

Step 1: *Clean the magnet mounting location. Use coarse sandpaper or a wire brush. Complete by wiping with a rag soaked in solvent.*

Step 2: *Using Figure 7.12 select the number of magnets to be used.*

Step 3: *Cut a 2" strip of paper approximately 11" long. Wrap this strip around the drive shaft and mark paper as shown in Figure 7.4. This will give you the total distance around the drive shaft (circumference). Cut the strip at this mark.*

Step 4: *Measure length of the strip and divide this number by the number of magnets your vehicle requires. Mark these locations on the strip. These are the center lines for the magnets.*

Step 5: Tape the strip around the drive shaft at the location chosen for the magnets. Remove backing paper from magnets and press one magnet next to each mark on the paper strip (place magnet on the cleaned drive shaft, not the paper). Be sure magnet tabs are lengthwise on the shaft. See Figure 7.6.

Step 6: While rotating the shaft, carefully snap one wire into one set of magnet slots. Loosely wrap the wire to hold it in place. Snap the second wire into the remaining slots making sure the ends are nearly opposite the first wire, as shown in Figure 7.6 or 7.11.

Step 7: Carefully pull wires tight, and wrap with a pair of pliers. Pull down as you twist to avoid breaking the wire. Now take the loose ends and wrap through the opposite wire and twist to remove any excess slack, see Figure 7.6. The wires actually hold the magnets onto the drive shaft. The double-faced tape is used only to temporarily hold the magnets until the wire is attached.

Step 8: Spin the drive shaft by hand and check for any clearance problems. Remember that the drive shaft position will change with the suspension. See Figure 7.3.

SPEEDSENSOR INSTALLATION

Step 9: Assemble the speed coil and bracket with nut and lock washer. Use of mounting bracket will be determined by the specific installation. Refer to Figures 7.5 and 7.10. In some cases installation may be easier if the bracket is bent or cut to a specific shape.

Step 10: Determining the location for the speedsensor/bracket assembly, the speedsensor must be pointing directly at the centerline of the shaft and there should be 3/8" (10 mm) clearance between the speedsensor and the magnets. See Figures 7.9.

Step 11: Use the bracket as a template to mark and center punch two hole locations. Drill two 3/16" diameter holes. Mount the speedsensor/bracket assembly using two 1/4" x 3/4" sheet metal screws. Be sure bracket is mounted so it will not vibrate during vehicle movement.

CAUTION: Before drilling any holes, make sure there are no parts which may be damaged on the other side of the metal. Double check for any wiring harness which might be easily damaged by the drill bit.

NOTICE: If the speed coil is closer than 1/4", there is a possibility that the magnets will strike the coil. If the coil is more than 1/2" from the magnets, the cruise control may not function properly.

Step 12: Route the black and gray paired wires to the speedsensor and attach to the terminals. (It does not matter which way the wires are attached).

NOTE: Make sure these wires are not run next to hot engine parts or electrical items such as spark plug wires or ignition systems, as an interference could occur causing the cruise control to surge.

NOTE: This magnet kit cannot be used on Hondas.

Figure 1

DASH BOARD TEMPLATE

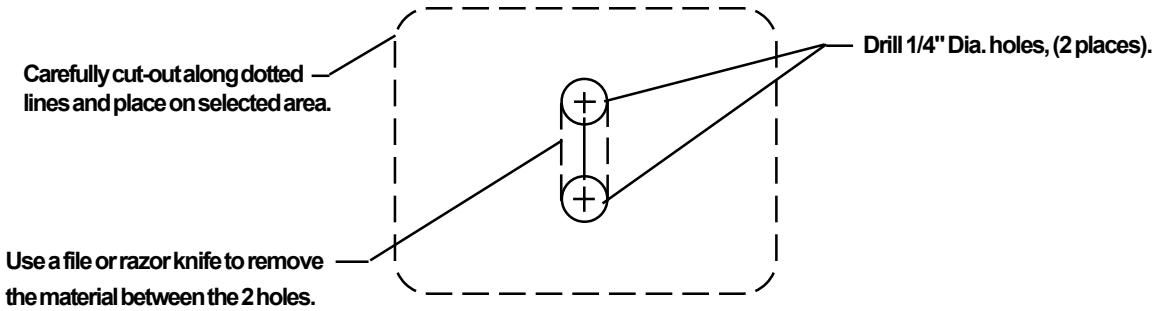

Figure 2

CONTROL SWITCH MOUNTING

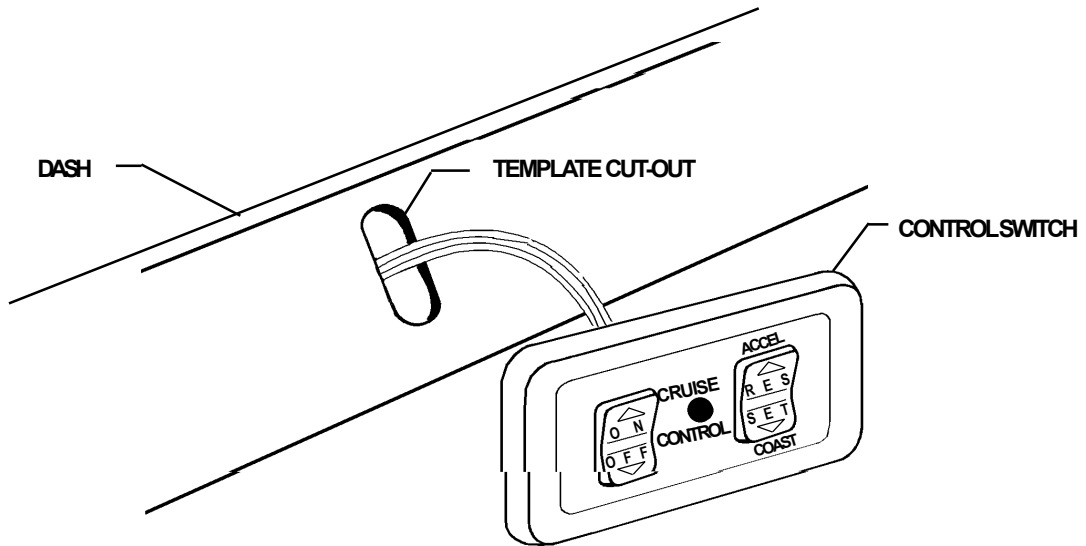
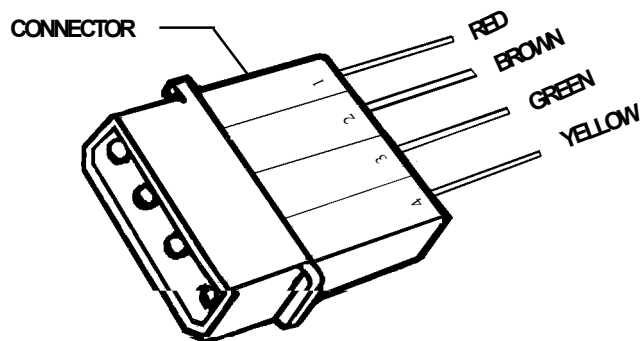

Figure 3

CONTROL SWITCH CONNECTIONS



Free Manuals Download Website

<http://myh66.com>

<http://usermanuals.us>

<http://www.somanuals.com>

<http://www.4manuals.cc>

<http://www.manual-lib.com>

<http://www.404manual.com>

<http://www.luxmanual.com>

<http://aubethermostatmanual.com>

Golf course search by state

<http://golfingnear.com>

Email search by domain

<http://emailbydomain.com>

Auto manuals search

<http://auto.somanuals.com>

TV manuals search

<http://tv.somanuals.com>