



Commander*MT*[®] System



installation guide

XMRVRFM002

Table of Contents

Table of Contents	2
Congratulations	3
FCC Information	4
Cautions and Warnings	5
CommanderMT Receiver Kit Components	6
Installation/Wiring Precautions	7
Setting Up and Installing Your Kit	8
Cabling Interconnections	8
Interconnect Diagram	9
Antenna Installation	10
CommanderMT Display Controller Installation	13
Using the DIN Opening Trim Bezel	13
Preferred Location	13
Locating the Display Controller	14
Installing the Mini-Tuner	15
Installing the Cradle and Interconnecting Cables	15
Using the Snap-On Mounting Plate	17
Connection Options	18
FM Direct Wiring	18
Low-Level Audio Output	19
Warranty	20

Congratulations

Thank you for purchasing the Audiovox **CommanderMT** XM® Satellite Radio System. You are one step closer to experiencing the latest innovation in XM® Satellite Radio. XM® Satellite Radio will revolutionize your vehicle or in-home entertainment.

XM® features over 170 digital channels — The most commercial-free music, over 30 channels of news, sports, talk and entertainment, over 20 dedicated channels of XM® Instant Traffic & Weather, and the deepest play-list in the industry with access to over 2 million titles!

XM® Satellite Radio service gives you the power to choose what you want to hear - wherever and whenever you want it. XM® is America's #1 Satellite Radio provider with over 4 million customers.

Your Audiovox **CommanderMT** XM® Satellite Radio System consists of accessory Vehicle Kit components required for your specific installation needs.

Required subscription for service sold separately.

Installation costs and other fees and taxes may apply, including a one-time activation fee. All fees and programming subject to change. College sports games subject to availability. Subscriptions subject to Customer Agreement included with the XM Welcome Kit and available at www.xmradio.com. Only available in the 48 contiguous United States.

© 2007 XM® Satellite Radio Inc. XM® is a trademark of XM® Satellite Radio. All rights reserved. All other trademarks are the property of their respective owners.

FCC Information

NOTE: This equipment has been tested and found to comply with the limits for a Class B digital device, pursuant to Part 15 of the FCC Rules. These limits are designed to provide reasonable protection against harmful interference in a residential installation. This equipment generates, uses and can radiate radio frequency energy and, if not installed and used in accordance with the instructions, may cause harmful interference to radio communications. However, there is no guarantee that interference will not occur in a particular installation. If this equipment does cause harmful interference to radio or television reception, which can be determined by turning the equipment off and on, the user is encouraged to try to correct the interference by one or more of the following measures:

- Reorient or relocate the receiving antenna.
- Increase the separation between the equipment and receiver.
- Connect the equipment into an outlet on a circuit different from that to which the receiver is connected.
- Consult the dealer or an experienced radio/TV technician for help.

This device complies with Part 15 of the FCC Rules. Operation is subject to the following two conditions: (1) This device may not cause harmful interference, and (2) this device must accept any interference received, including interference that may cause undesired operation.

The user is cautioned that changes or modifications not expressly approved by XM® Satellite Radio, Inc. can void the user's authority to operate this device.

Please note that the cables and antenna wire that has been supplied with your car installation kit are supplied with permanently attached ferrite beads. It is the responsibility of the user to use the cable and antenna wire with the ferrite beads.

By adhering to these warnings and safety considerations, stated in the manual and by XM®, accidents.

Cautions and Warnings

1. Do not install the **CommanderMT** Display Controller in a position that hinders your view through the windshield, or obstructs viewing of the dashboard indicators and displays.
2. Do not install the Display Controller where it may obstruct the operation or deployment of safety devices, such as airbags, etc.
3. Do not allow operation of the unit to detract from safe driving practices; remember that you are responsible as the vehicle operator to adhere to all safe driving and traffic regulations.
4. By adhering to these warnings and safety considerations, serious accidents and/or personal injury can be avoided.

CommanderMT Receiver Kit Components

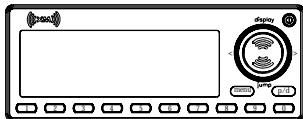

**CommanderMT
Display Controller**



Remote Control

**XM
Mini-Tuner**



**Interconnect
Cradle**

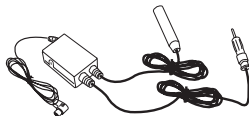

FM Direct Adapter

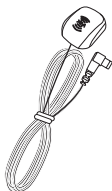

**XM Car
Antenna**

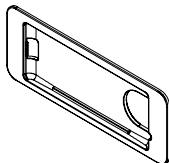

**DIN Opening
Trim Bezel**

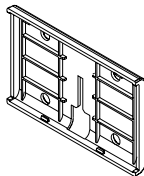

**Snap-On
Mounting
Plate**



**12 Vdc
Power Cable**

Installation/Wiring Precautions

1. To prevent a short-circuit, be sure to turn off the ignition and remove the negative (-) battery cable prior to installation. Connect power wires last.
2. Do not install the **CommanderMT** Display Controller in locations exposed to direct sunlight, or in areas subject to extreme temperatures, or damage could occur.
3. Incorrect installation may cause damage to the system. Mount the system components using the suggested methods recommended in this manual.
4. Be careful not to crimp or twist the vehicle wiring.
5. Use only the 12 Volt DC Power Cable supplied. Use of an alternative power source could damage the **CommanderMT** System components or vehicle wiring.
6. Locate the **CommanderMT** Display Controller in an area of the vehicle where it will not obstruct the driver's operation of the vehicle and where it will not pose a risk to driver or passengers in the event of an emergency stop.

Setting Up and Installing Your Kit

NOTE: The XM® signal can be received and processed virtually anywhere as long as there are no obvious satellite signal obstructions such as nearby buildings, high terrain, parking garages or tunnels.

1. Cabling Interconnections

You can begin to enjoy XM® Satellite Radio as soon as the **CommanderMT** System Vehicle Kit installation is complete. Set up your Audiovox **CommanderMT** System using the following installation instructions, or enlist the help of a professional installer:

WARNING: Professional installation is recommended. Failure to properly follow all installation instructions may result in personal injury or damage to your **CommanderMT** System components, your vehicle, or your vehicle Audio/Video (A/V) system.

Interconnect Diagram

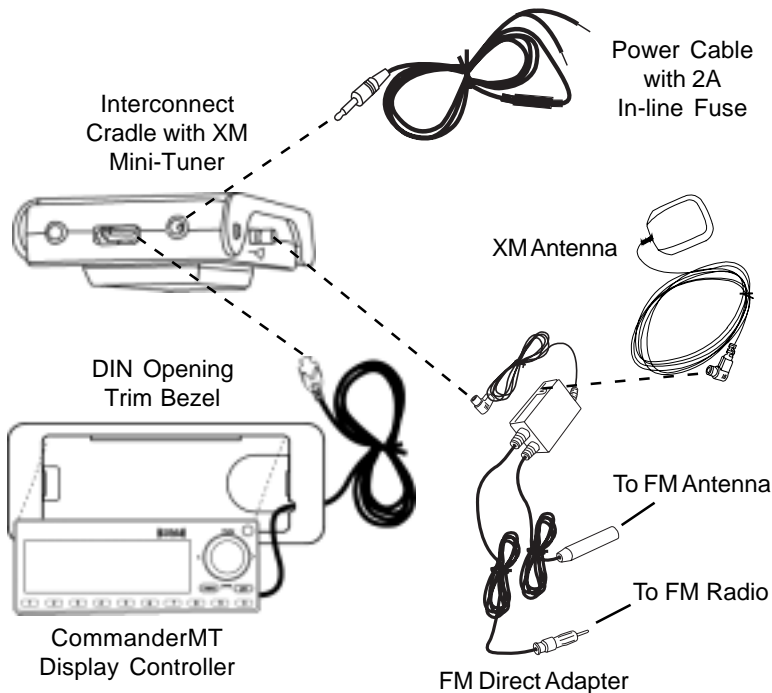

2. Important!

It is very important to make your power connection to a source that only supplies 12V when the vehicle key is in the accessory or ignition **ON** position. A connection to a 12V source that is always on, regardless of the key position, can lead to a battery drain if the **CommanderMT** System is left on when you leave your vehicle.



Ignition Switch Accessory/On-Off Positions

3. Antenna Installation

Where to locate

- Best reception is achieved with the antenna mounted on a flat portion of a metal vehicle roof with at least 12" x 12" of surface area and a minimum of 6" from a window or sunroof.
- If the vehicle has roof racks or skid ribs, it may be necessary to mount the antenna off-center.
- If the vehicle roof does not provide sufficient metal surface area, then the antenna can be mounted on the metal trunk lid. It is recommended that it be mounted at least several inches from the rear window to ensure adequate clearance.

- Caution:**
1. Do not install the antenna inside the vehicle passenger compartment. Mounting the antenna in the passenger compartment either on the front dashboard, or on the rear window deck area will cause reception issues and must be avoided.
 2. Mounting the antenna on a non-metallic surface will also result in severe degradation in reception.
- If an appropriate antenna mounting location cannot be identified, contact your local retailer installation department for additional guidance.

Cable routing

- Once you have mounted the antenna in the correct location, plan how to route the cable from this location to the receiver Inteconnect Cradle, avoiding blocked passages and any obstructions that could kink, crimp, twist or chafe the cable. If the cable will come into contact with a rough metal opening, use a rubber grommet to prevent damage.
- For antenna mounting locations at the front or middle of the roof, the cable can be routed down along the door jamb and into the car. In some cars, the cable may be brought into the vehicle through the grommet in the door jamb which carries the power window and power door lock wires. If the cable does not fit easily through this grommet, do not try to force it through. Instead, route the cable under the weather seal near the bottom of the door.

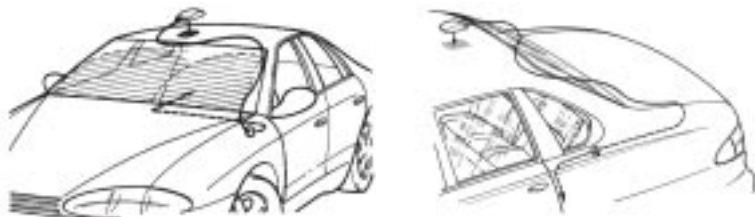

Antenna Mounting Methods

- For antenna mounting locations at the rear of the roof, the antenna cable can be routed into the vehicle through the trunk. Always route the cable under the weather seal near the lowest part of the trunk to reduce possible water leaks.
- Use pre-existing wiring channels created by the vehicle manufacturer whenever possible.

Tools required

- The antenna contains a powerful magnet that will secure it to a metal roof under normal driving conditions. No additional tools should be necessary to mount the antenna.

4. *CommanderMT Display Controller Installation*

Be sure to locate your Display Controller below the top of the dash in your vehicle to keep the unit within easy reach while driving. Choosing a lower location in your installation should also make it easier to manage the cables and achieve a more desirable appearance when the installation is completed. See illustration below and be sure to locate your Display Controller within the outlined shaded areas.

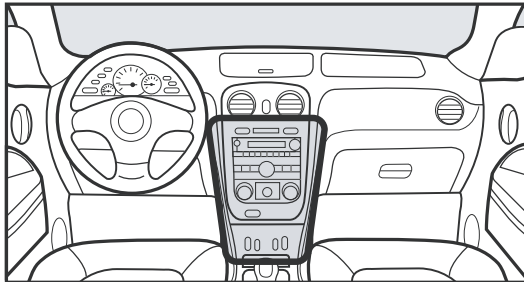

The **CommanderMT** Display Controller can be installed using the DIN opening trim bezel or a snap-on mounting plate as shown below. The trim bezel permits in-dash or center console mounting, while the mounting plate can be used with optional custom brackets, such as swivel or vent mounts.

a. Using the DIN Opening Trim Bezel

Preferred location

Your **CommanderMT** Receiver Kit includes a DIN opening trim bezel for mounting the display controller into an existing dashboard or console opening.

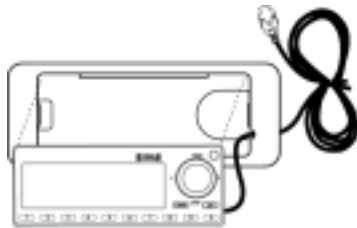

Using the DIN Opening
Trim Bezel

b. Using the Snap-On Mounting Plate

To attach the **CommanderMT** cradle to optional mounting devices that are readily available at retail, attach the snap-on mounting plate to the rear of the **CommanderMT** Display Controller as shown below.

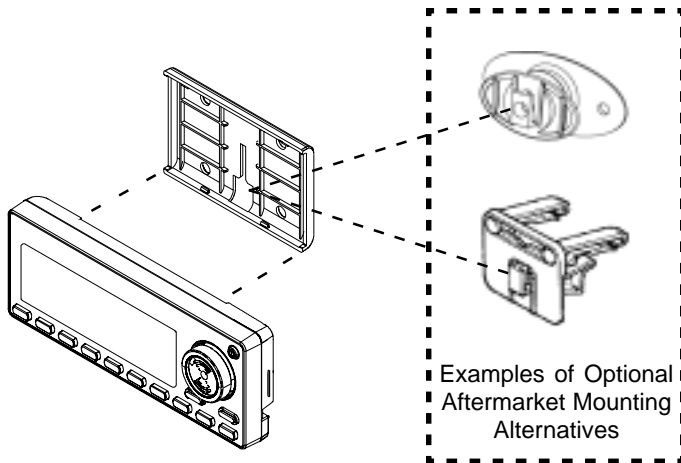

5. Connection Options

The **CommanderMT** System provides an audio output signal in two ways:

- a. **FM Direct Wiring** - The FM direct adapter supplies a hard-wired FM output, provided the FM Frequency option of the XM Mini-Tuner is turned on and tuned to an unused FM frequency.

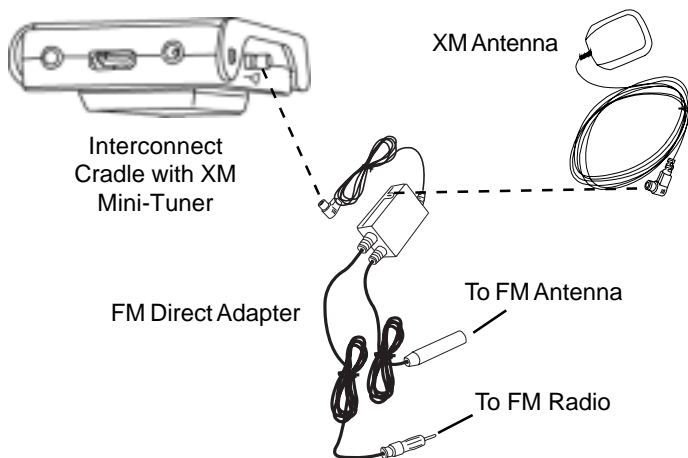

- b. Low-Level Audio Output** - For vehicle radio head units with auxiliary audio inputs, the audio signal can be routed through an optional audio cable (Part No. SAT-RCA) and applied to the auxiliary inputs of a radio or entertainment system. In this case, to listen to the audio, the System Receiver FM modulator option must be disabled (FM Frequency **Off**), as indicated in the **CommanderMT** System User Guide.

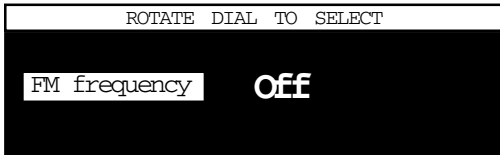

Interconnect Cradle with XM
Mini-Tuner



To Vehicle Radio
Low Level Audio
Inputs



Optional Audio
Cable SAT-RCA

6. Cable Routing and Component Installation

Once you have established power connections, Display Controller and antenna placement, and audio connection, route all cables to the location where you will mount the Interconnect Cradle. When you have plugged the power and antenna jacks into the cradle, re-use the cable twist ties that were provided with the power and car antenna cables and always be sure to gather, bundle, twist-tie, and secure any excess cable remaining after determining the best location for your satellite radio installation.

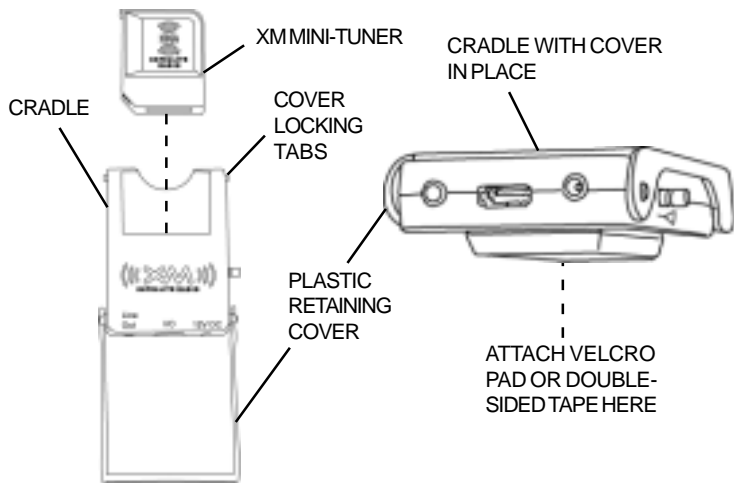

- a. *Installing the Cradle and Interconnecting Cables*** - Locate the Interconnect Cradle in a readily accessible location, such as the glove compartment, console compartment, or under the dashboard, so that the XM Mini-Tuner can be removed or replaced. Note also that the cradle must be situated close enough to comply with the **CommanderMT** Display Controller cable and Power Cable lengths (6').
- b. *Installing the Mini-Tuner*** - Install the XM Mini-Tuner in the cradle by inserting the tuner into the cradle slot until the cradle and tuner connectors mate together. You will feel the tuner connector click into place. Fold the plastic retainer cover over the cradle and press down until the cradle tabs lock into the the cover side holes. The XM Mini-Tuner is now secured in place in the cradle.

Good installation practices should be observed when mounting any component to avoid vibration, movement or rattling after installation. When routing cables, avoid blocked passages and any obstructions that could kink, crimp, twist, or chafe the cables. Components should be secured in place using methods such as Velcro, double-sided foam tape, etc.

**AUDIOVOX®****12 MONTH LIMITED WARRANTY*****FM Satellite Radio*****XMRVRFM002**

AUDIOVOX ELECTRONICS CORPORATION (the Company) warrants to the original retail purchaser of this product that should, under normal use and conditions, be proven defective in material or workmanship within 12 months from the date of original purchase, such defect(s) will be repaired or replaced with new or reconditioned product (at the Company's option) without charge for parts and repair labor.

To obtain repair or replacement within the terms of this warranty, the product is to be delivered with proof of warranty coverage (e.g. dated bill of sale), specification of defect(s), transportation prepaid, to an approved warranty station or the Company at the address shown below.

This Warranty does not extend to the elimination of externally generated static or noise, to costs incurred for installation, removal or reinstallation of the product, or to damage to speakers, accessories, or electrical systems. Warranty does not apply to malfunction of satellite transmissions, repeater signals or audio systems or to damage caused by poor installation of included components such as magnetic roof mount antenna, display control unit or receiver docking station.

This Warranty does not apply to any product in the opinion of the Company that has been damaged through alteration, improper installation, mishandling, misuse, neglect, accident, or by removal or defacement of the factory serial number number/bar code label(s). THE EXTENT OF THE

COMPANY'S LIABILITY UNDER THIS WARRANTY IS LIMITED TO THE REPAIR OR REPLACEMENT PROVIDED ABOVE AND, IN NO EVENT, SHALL THE COMPANY'S LIABILITY EXCEED THE PURCHASE PRICE PAID BY PURCHASER FOR THE PRODUCT.

This Warranty is in lieu of all other express warranties or liabilities. ANY IMPLIED WARRANTIES, INCLUDING ANY IMPLIED WARRANTY OF MERCHANTABILITY, SHALL BE LIMITED TO THE DURATION OF THIS WRITTEN WARRANTY. ANY ACTION FOR BREACH OF ANY WARRANTY HEREUNDER INCLUDING ANY IMPLIED WARRANTY OF MERCHANTABILITY, MUST BE BROUGHT WITHIN 24 MONTHS FROM DATE OF ORIGINAL PURCHASE. IN NO CASE SHALL THE COMPANY BE LIABLE FOR ANY CONSEQUENTIAL OR INCIDENTAL DAMAGES FOR BREACH OF THIS OR ANY OTHER WARRANTY, EXPRESS OR IMPLIED, WHATSOEVER. No person or representative is authorized to assume for the Company any liability other than expressed herein in connection with the sale of this product.

Some states do not allow limitations on how long an implied warranty lasts or the exclusion or limitation of incidental or consequential damage so the above limitations or exclusions may not apply to you. This Warranty gives you specific legal rights and you may also have other rights which vary from state to state.

U.S.A.: Audiovox Electronics Corporation ■ 150 Marcus Blvd ■ Hauppauge, New York 11788 (1-800-645-4994)

Canada: CALL 1-800-645-4994 for Location of Warranty Station Serving Your Area



Audiovox Electronics Corporation
150 Marcus Blvd.
Hauppauge, New York 11788
U.S.A.
1 800 645 4994

www.audiovox.com

XM name and related logos are trademarks of XM Satellite Radio Inc.

♻️ Printed on Recycled Paper
©2007 Audiovox Electronics Corporation. All rights reserved.

XMRVRFM002

Free Manuals Download Website

<http://myh66.com>

<http://usermanuals.us>

<http://www.somanuals.com>

<http://www.4manuals.cc>

<http://www.manual-lib.com>

<http://www.404manual.com>

<http://www.luxmanual.com>

<http://aubethermostatmanual.com>

Golf course search by state

<http://golfingnear.com>

Email search by domain

<http://emailbydomain.com>

Auto manuals search

<http://auto.somanuals.com>

TV manuals search

<http://tv.somanuals.com>