



Installation Instructions for Detachable Face Stereo Systems

CALL TOLL-FREE FOR ANSWERS TO INSTALLATION PROBLEMS

Continental U.S. : 1 - 800 - 645 - 4994
Monday - Friday : 9:00 AM - 7:00 PM Eastern Time
Saturday : 9:00 AM - 5:00 PM Eastern Time

IMPORTANT - RETAIN THIS DOCUMENT FOR FUTURE REFERENCE.

Consignes d'Installation des Systèmes Stéréo avec Panneau Avant Amovible

APPELEZ LE NUMERO VERT POUR TOUTE QUESTION CONCERNANT L'INSTALLATION

Territoire Continental Des E.U. : 1 - 800 - 645 - 4994
Lundi au Vendredi : 9 H - 19 H Heure de la Côte Est
Samedi : 9 H - 17 H Heure de la Côte Est

IMPORTANT - CONSERVER CE DOCUMENT POUR TOUTE REFERENCE ULTERIEURE.

Instrucciones para la Instalación de Sistemas Estereofónicos con Panel Delantero Desmontable

LLAME SIN CARGO PARA FORMULAR PREGUNTAS SOBRE PROBLEMAS DE INSTALACION

Territorio Continental De EE.UU. : 1 - 800 - 645 - 4994
Lunes a Viernes : 9:00 AM - 7:00 PM Zona Horaria del Este
Sabados : 9:00 AM - 5:00 PM Zona Horaria del Este

IMPORTANTE - GUARDE ESTAS INSTRUCCIONES PARA CONSULTARLAS EN EL FUTURO.

INSTALLATION INSTRUCTIONS

UNIVERSAL INSTALLATION PROCEDURE

This unit is designed to fit into a standard DIN dashboard opening of 182 x 52 mm, common in many cars. If your car does not have an existing opening of this size, it will be necessary to cut or file an opening to these dimensions. The rear side (without the lip) of the mounting sleeve may be used as a template to cut the required opening.

In some cases, a special installation or adaptor kit may be required to properly mount the unit. For assistance or answers to installation problems, call Audiovox toll-free at **1-800-645-4994** (Continental U.S. only, 9:00 AM-7:00 PM Eastern Time Monday-Friday, 9:00 AM-5:00 PM Saturday, Holidays excluded), or consult with your local car stereo specialist shop.

1. Remove the detachable front panel if it is attached to the chassis by pushing the "Release" button. Slide the mounting sleeve off of the chassis. If it is locked into position, use the removal tools (supplied) to disengage it.
2. Check the dashboard opening size by sliding the mounting sleeve into it. If the opening is not large enough, carefully cut or file as necessary until the sleeve easily slides into the opening. Do not force the sleeve into the opening or cause it to bend or bow.
3. Check that there will be sufficient space behind the dashboard for the radio chassis.
4. In most installations, it is more convenient to complete the wiring before mounting the radio in the dashboard. Follow the wiring diagram carefully and make certain all connections of the wiring harness are secure and insulated with wire nuts or electrical tape to insure proper operation of the unit. After completing the wiring connections, plug the 16-pin connector into the mating socket on the rear of the chassis, attach the front panel, and turn the unit on to confirm operation (ignition switch must be "on"). If unit does not operate, re-check all wiring until problem is corrected. Once proper operation is achieved, turn off the ignition switch, un-plug the wiring harness from the chassis, and proceed with final mounting of the chassis.
5. Locate the series of bend tabs along the top, bottom, and sides of the mounting sleeve. With the sleeve fully inserted into the dashboard opening, bend as many of the tabs outward as necessary so that the sleeve is firmly secured to the dashboard.
6. Place the radio in front of the dashboard opening so that the wiring (16-pin connector, antenna lead, RCA leads if used, etc.) can be brought through the mounting sleeve and plugged into the respective sockets on the rear of the chassis.
7. Carefully slide the radio into the mounting sleeve making sure it is right-side-up until it is fully seated and the spring clips lock it into place.
8. Attach one end of the perforated support strap (supplied) to the screw stud on the rear of the chassis using the hex nut provided. Fasten the other end of the perforated strap to a secure part of the dashboard either above or below the radio using the screw and hex nut provided. Bend the strap to position it as necessary.
CAUTION: The rear of the radio must be supported with the strap to prevent damage to the dashboard from the weight of the radio or improper operation due to vibration.
9. Re-attach the front panel to the chassis and test radio operation by referring to the Operating Instructions for the unit.

REMOVING THE RADIO FROM THE MOUNTING SLEEVE

1. Should it be necessary to remove the radio for servicing or other reasons, first remove the detachable front panel.
2. Remove the rear support strap by taking off the hex nut securing it to the screw stud on the rear of the chassis.
3. Use the removal tools (supplied) to disengage the side spring clips and pull the radio out of the mounting sleeve.

UNIVERSAL INSTALLATION USING MOUNTING SLEEVE

EXISTING DASH OPENING
 FILE EDGES TO FIT IF NECESSARY - DO NOT OVERFILE
 NOTE: IF DASH IS SOLID, USE REAR SIDE (WITHOUT THE LIP)
 OF MOUNTING SLEEVE AS A TEMPLATE & CUT OPENING

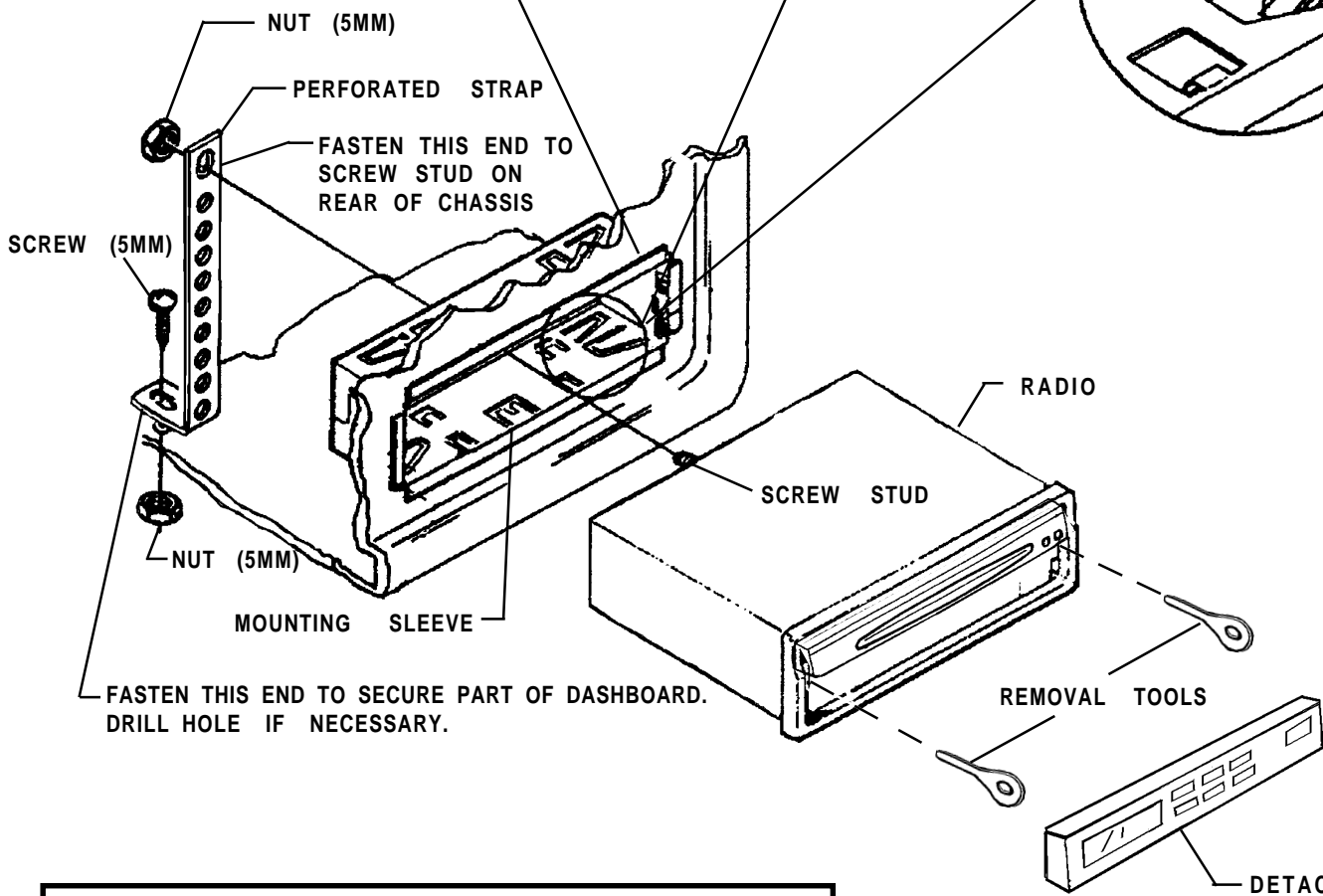
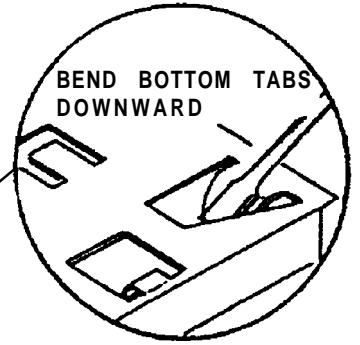
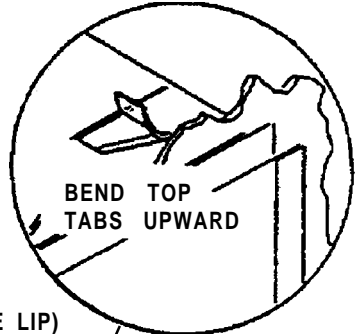

CAUTION:
 FOR PROPER OPERATION OF THE CD PLAYER, THE CHASSIS MUST BE MOUNTED WITHIN 20° OF HORIZONTAL. MAKE SURE THE UNIT IS MOUNTED WITHIN THIS LIMITATION.

20° MAX.
 FRONT PANEL
 SIDE VIEW OF CHASSIS

WIRING DIAGRAM

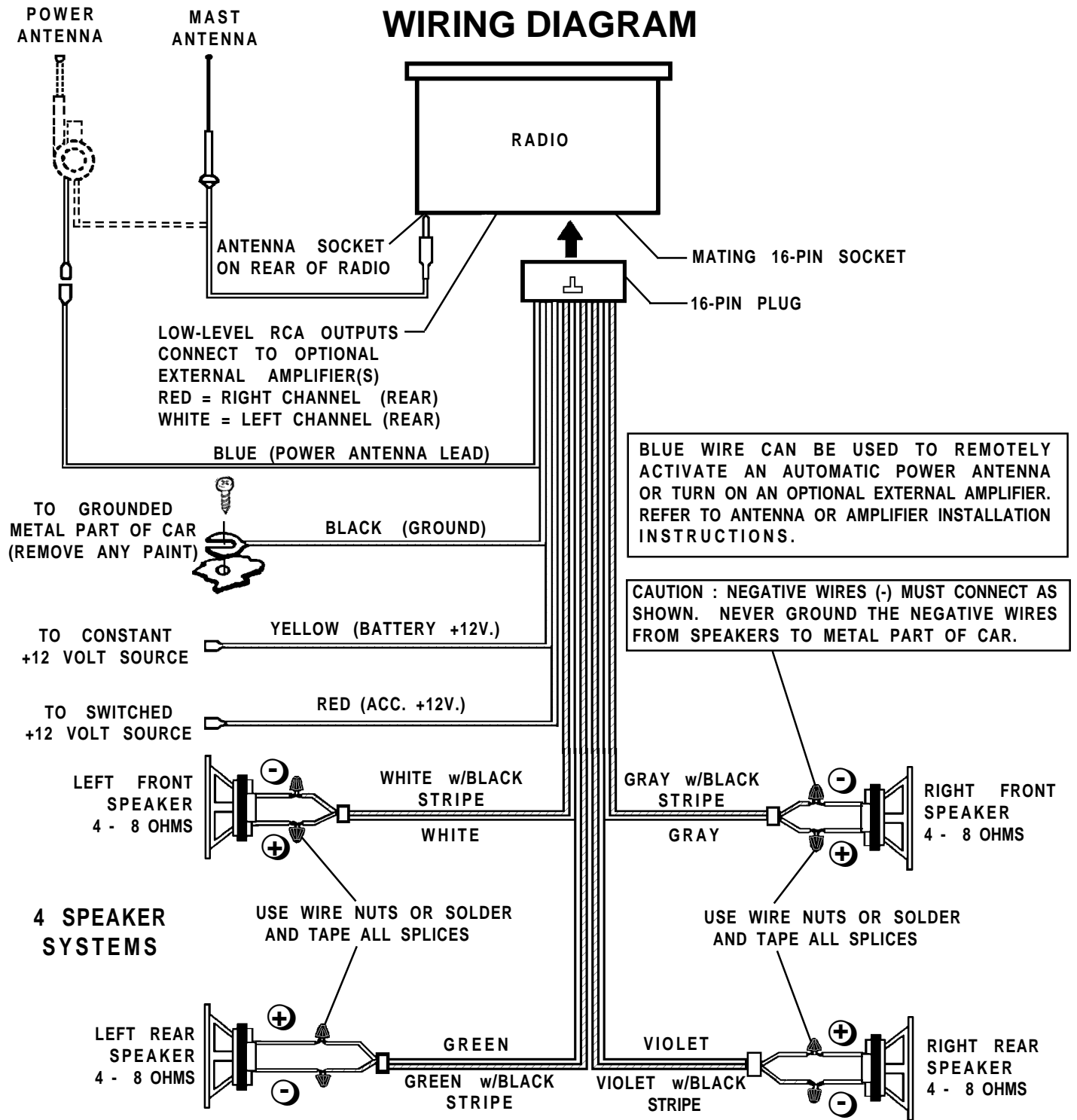

CAUTION!

- THE AMPLIFIERS IN THIS RADIO ARE ONLY DESIGNED FOR USE WITH 4 SPEAKERS.
- NEVER COMBINE (BRIDGE) OUTPUTS FOR USE WITH 2 SPEAKERS.
- NEVER GROUND NEGATIVE SPEAKER LEADS TO CHASSIS GROUND.
- FAILURE TO WIRE CORRECTLY MAY CAUSE DAMAGE TO THE RADIO.

Free Manuals Download Website

<http://myh66.com>

<http://usermanuals.us>

<http://www.somanuals.com>

<http://www.4manuals.cc>

<http://www.manual-lib.com>

<http://www.404manual.com>

<http://www.luxmanual.com>

<http://aubethermostatmanual.com>

Golf course search by state

<http://golfingnear.com>

Email search by domain

<http://emailbydomain.com>

Auto manuals search

<http://auto.somanuals.com>

TV manuals search

<http://tv.somanuals.com>