



LG

Life's Good

HCS6300 CodePlus™ Series MUX/MOD Feature Card

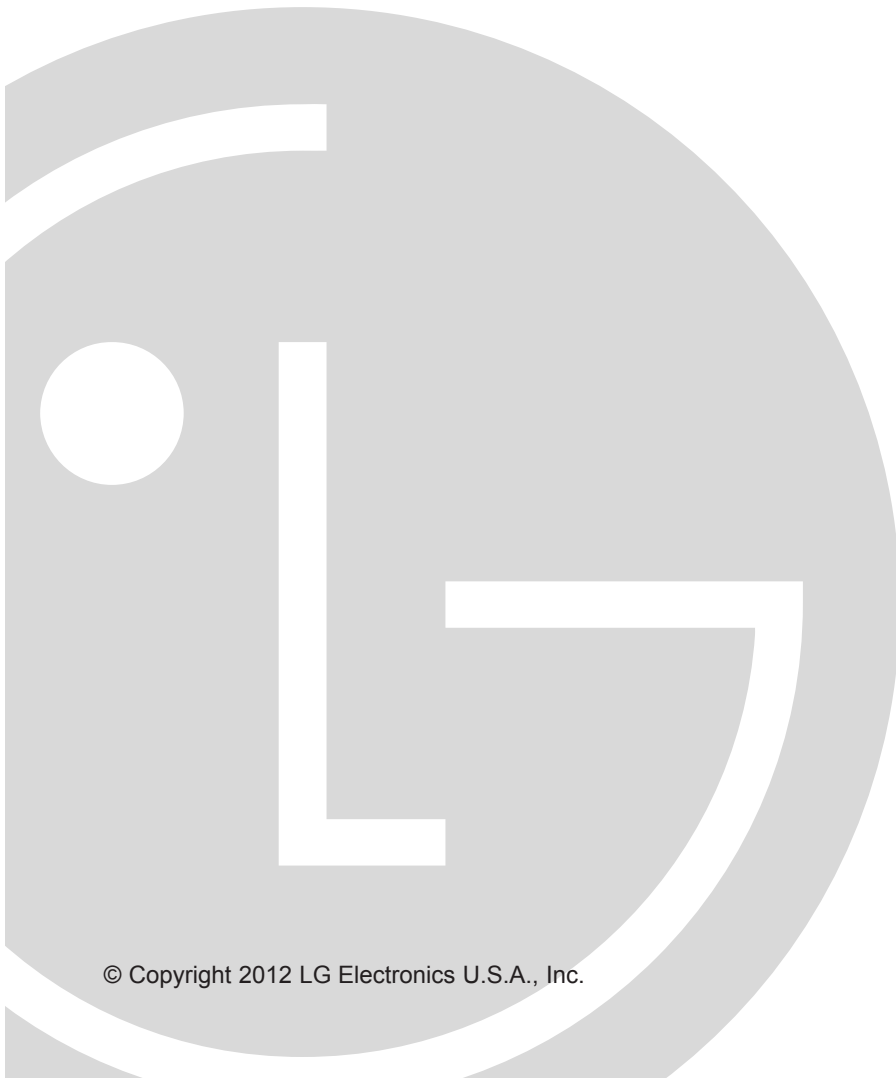

Installation & Setup Guide Warranty



For Customer Support/Service, please call: **1-888-865-3026**

The latest product information and documentation is available online at:

www.LGolutions.com/products

	WARNING RISK OF ELECTRIC SHOCK DO NOT OPEN	
---	---	---

WARNING:
TO REDUCE THE RISK OF ELECTRIC SHOCK DO NOT REMOVE COVER (OR BACK). NO USER-SERVICEABLE PARTS INSIDE. REFER TO QUALIFIED SERVICE PERSONNEL. ALL CARDS MUST BE INSERTED AND REMOVED BY QUALIFIED SERVICE PERSONNEL ONLY.

 The lightning flash with arrowhead symbol, within an equilateral triangle, is intended to alert the user to the presence of uninsulated “dangerous voltage” within the product’s enclosure that may be of sufficient magnitude to constitute a risk of electric shock to persons.

 The exclamation point within an equilateral triangle is intended to alert the user to the presence of important operating and maintenance (servicing) instructions in the literature accompanying the appliance.

WARNING:

TO PREVENT FIRE OR SHOCK HAZARDS, DO NOT EXPOSE THIS PRODUCT TO RAIN OR MOISTURE.

Apparatus shall not be exposed to dripping or splashing and no objects filled with liquids, such as vases, shall be placed on the apparatus.

L'appareil ne doit pas être exposé à des égouttements d'eau ou des éclaboussures et de plus qu'aucun objet rempli de liquide tel que des vases ne doit être placé sur l'appareil.

REGULATORY INFORMATION:

This equipment has been tested and found to comply with the limits for a Class A digital device, pursuant to Part 15 of the FCC Rules. These limits are designed to provide reasonable protection against harmful interference when the equipment is operated in a commercial environment. This equipment generates, uses and can radiate radio frequency energy and, if not installed and used in accordance with the instruction manual, may cause harmful interference to radio communications. Operation of this equipment in a residential area is likely to cause harmful interference in which case the user should be required to correct the interference at his own expense.

CAUTION:

Do not attempt to modify this product in any way without written authorization from LG Electronics U.S.A., Inc. Unauthorized modification could void the user's authority to operate this product.

NOTE TO SATELLITE DISH INSTALLER:

This reminder is provided to call your attention to Articles 810 and 820 of the 2002 National Electrical Code. Refer to Article 810, in particular 810-1 and 810-15, for required grounding of the metal dish antenna. Refer also to the 810-2 which, by reference to Article 820, requires that the satellite dish coaxial cable shield be connected to the grounding system of the building as close to the point of cable entry as practical.

COMPLIANCE:

The responsible party for this product's compliance is: LG Electronics U.S.A., Inc.
2000 Millbrook Drive, Lincolnshire, IL 60069, USA • Phone: 1-847-941-8000

Marketed and Distributed in the United States by LG Electronics U.S.A., Inc.
2000 Millbrook Drive, Lincolnshire, IL 60069

IMPORTANT SAFETY INSTRUCTIONS

Important safeguards for you and your new product

THIS PRODUCT HAS BEEN MANUFACTURED AND TESTED WITH SAFETY IN MIND. IMPROPER USE, HOWEVER, CAN RESULT IN POTENTIAL ELECTRICAL SHOCK OR FIRE HAZARDS. TO AVOID DEFEATING THE SAFEGUARDS THAT HAVE BEEN BUILT INTO THIS PRODUCT, PLEASE READ AND OBSERVE THE FOLLOWING SAFETY POINTS WHEN INSTALLING AND USING THIS PRODUCT.

1. Read these instructions.

Read all the safety and operating instructions before operating the product.

2. Keep these instructions.

Retain the safety and operating instructions for future reference.

3. Heed all warnings.

Adhere to all warnings on the product and in the operating instructions.

4. Follow all instructions.

Follow all operating and use instructions.

5. Do not use this apparatus near water.

Do not use this product near water or moisture or in an area, such as a basement, that might become flooded.

6. Clean only with dry cloth.

Unplug this product before cleaning. Do not use liquid cleaners or aerosol cleaners.

7. Refer all servicing to qualified service personnel.

Servicing is required when the apparatus has been damaged in any way, liquid has been spilled or objects have fallen into the apparatus, the apparatus has been exposed to rain or moisture, does not operate normally, or has been dropped.

8. Object and Liquid Entry

Never push objects of any kind into this product through openings as they may touch dangerous voltage points or short-out parts that could result in a fire or electric shock. Never spill liquid of any kind on the product.

9. Outdoor Use



Warning: To prevent fire or shock hazards, do not expose this product to rain or moisture.

10. Wet Location

The apparatus shall not be exposed to dripping or splashing and no objects filled with liquids, such as vases, shall be placed on the apparatus.

11. Test Equipment

In some cases, LG has supplied or recommended the use of test equipment and devices for the setup and testing of the equipment. The operation and maintenance of test equipment is described in their associated instruction manuals. Please refer to these manuals for explicit instructions regarding the safe use and handling of the equipment.

12. Damage Requiring Service

Unplug this product from the wall power outlet and refer servicing to qualified service personnel under the following conditions:

- a. If liquid has been spilled, or objects have fallen into the product.
- b. If the product has been exposed to rain or water.
- c. If the product does not operate normally by following the operating instructions. Adjust only those controls that are covered by the operating instructions, as an improper adjustment of other controls may result in damage and will often require extensive work by a qualified technician to restore the product to its normal operation.

(Continued on next page)

IMPORTANT SAFETY INSTRUCTIONS

(Continued from previous page)

- d. If the product has been dropped or the cabinet has been damaged.
- e. If the product exhibits a distinct change in performance.



Caution: Refer all servicing to qualified service personnel.

13. Servicing



Caution: These servicing instructions are for use by qualified service personnel only. To reduce the risk of electrical shock, do not perform any servicing other than that described in the operating instructions unless you are qualified to do so.

14. Replacement Parts

When replacement parts are required, be sure the service technician uses replacement parts specified by the manufacturer or that have the same characteristics as the original parts. Unauthorized substitutions may result in fire, electric shock, or other hazards.

15. Safety Check

Upon completion of any service or repairs to this product, ask the service technician to perform safety checks to determine that the product is in proper operating condition.

Table of Contents

Safety Warnings	2	Set HCS6300 RF Channels	32
Important Safety Instructions.	3–4	Print the RF Channel Map	32
Table of Contents	5	Display a List of the Transcoder Cards Installed in the Chassis	33
Setup Information	6	Access Individual Transcoder Menus	33
HCS6300 Product Description	7	Perform an External Card Reset	33
Transcoder Product Description	8	Set the HCS6300 IP Address.	34
Card Description	9	Install a Pro:Idiom Key on All Transcoders	34
HCS6300 Functional Blocks	10	Reload the Pro:Idiom Key on All Transcoders	36
Installing a CodePlus Feature Card	11–12	Update HCS6300 and/or Transcoder Firmware	36
Satellite STB & HCS6300 Initialization & Setup Connections.	13	View MUX or Raw Bitrate Data	37
System Setup	14–15	Configure Card Number to Channel Assignments.	38
Typical System Installation.	14	Reset Password for Reload PI Key GUI Option.	39
Typical Flow Chart for HCS6300	15	Transcoder Menu Commands	40
Network and Communication Setup	16	Satellite Receiver Menu Commands	44
Configuration Options via GUI	17–30	Troubleshooting.	48
Access the CodePlus Transcoder Series Web GUI.	17	Specifications	49
Controller Menu Commands	17	Document Revision History / Notes	50
Transcoder Menu Commands	25	Open Source Software Notice.	51
Satellite STB Menu Commands.	27	Warranty	Back Cover
Configuration Options via Command Line	31–47		
Access the HCS6300 Main Menu	31		
View HCS6300 System Information.	32		

Setup Information

Check the following items before you begin HCS6300 installation and setup procedures.

HCS6300

- The HCS6300 feature card must be installed in a CodePlus™ card frame (Example: HCS6150R) with one or more CodePlus series transcoder cards (Example: HCS7710). Refer to the Installation & Setup Guide for the card frame to verify that the chassis is installed properly. **Note: All cards must be used in an LG-approved card frame for this product.**
- The HCS6300 must be installed in the card frame CONTROLLER slot. If another CodePlus feature card is currently installed in the CONTROLLER slot, the HCS6300 will replace it.
- The HCS6300 ships with an HCS6400 fan card. In an HCS6100R card frame, the HCS6400 fan card must be installed in Slot 7. If another CodePlus card is currently installed in Slot 7, the HCS6400 will replace it.
- For HCS6300 Service Port connections, you must use an FTDI TTL-USB cable (P/N TTL-232R-5V-AJ).

Channel Assignments

- Create a channel assignment plan for the installation site, or modify an existing plan to incorporate the RF output of the HCS6300. Ensure that up to four contiguous CATV channels are allocated for the HCS6300 RF output. The HCS6300 uses a 256-QAM modulation format, thereby occupying approximately 24 MHz of frequency spectrum.

The RF start channel is user-assigned during system setup, and the remaining channels are then automatically assigned per EIA-542 STD CATV frequency allocation standards. For example, if the RF start channel assignment is channel “2,” the three remaining channels will be “3” “4” and “5.” However, if the RF start channel assignment is “6,” the three remaining channels will be “95” “96” and “97.” Refer to EIA-542 STD CATV frequency allocation tables for further information as required.

The highest available RF channel number for the HCS6300 is “135.” Thus, to allocate all four channels available for HCS6300 RF output, the RF start channel must be set no higher than “132.”

Transcoders

- For HCS6300 MUX/MOD functionality, transcoder cards should be inserted in the following slots: 1, 2, 4, 5, 8, 9, 11, and 12. Refer to the Installation & Setup Guide for the transcoder cards to verify that the cards are installed properly.
- In a CodePlus HCS6100R card frame, it is possible to install up to three additional transcoders in the following slots: 3, 6, and 10. These additional transcoders must be connected to external modulators and upconverters. Refer to the Installation & Setup Guide for the transcoder cards for further information.

HCS6300 Product Description

The HCS6300 MUX/MOD controller is one of the LG CodePlus series feature cards.

Features

- Part of modular system, easily scaled for each application
- Controls up to eleven CodePlus transcoder cards with a single IP connection *
- Supports Pro:Idiom® encryption key maintenance
- Generates four contiguous 256-QAM cable channels, with up to two program streams multiplexed on each channel
- RF output available to connect to site's RF distribution system
- Short 3U height profile to minimize rack space usage



* While HCS6300 MUX/MOD functionality is only applicable for the transcoder cards installed in Slots 1, 2, 4, 5, 8, 9, 11, and 12, up to three additional transcoders (connected to external modulators and upconverters) may be installed in an HCS6100R card frame. Transcoder configuration options that are not tied directly to HCS6300 MUX/MOD functionality will also be available for any additional cards.

Transcoder Product Description

Typical HD Transcoder System Overview

The LG HCS6300 MUX/MOD feature card, when used with LG CodePlus series transcoders in a CodePlus card frame, represents an eight-program HDTV solution for commercial and institutional MATV systems (hotels, hospitals, etc.).

A typical Transcoder System with MUX/MOD functionality includes:

- An HCS6300 MUX/MOD feature card.
- One CodePlus HD transcoder card for each HD program offered in the facility's MATV system—up to eight programs supported.
- A CodePlus series card frame specified for both the HCS6300 and the transcoder card(s).
- DIRECTV® service. *
- A DIRECTV COM 23 satellite STB for each transcoder card. *
- A 19-inch rack for mounting. *
- Miscellaneous cables and installation hardware (see also setup information on page 6). *

The integrated elements of the Transcoder System:

- Receive up to eight HD programs from DIRECTV.
- Transcode the received digital video and audio streams to MPEG-4 (HCS6700 transcoders) or MPEG-2 (HCS7700/HCS7710 transcoders) transport streams.
- Encrypt the transcoded digital data streams with Pro:Idiom content protection.
- Multiplex the encrypted streams into four streams of two programs each.
- Modulate and upconvert the multiplexed streams in four contiguous RF channels.

A Pro:Idiom compatible television with a QAM/VSB tuner is required to view premium HD content. A proper session ID must be set at the TV in order for Pro:Idiom decryption to be enabled. LG's Pay-Per-View (PPV) partners can set up this session through their interface. LG's Free-To-Guest (FTG) Mode of operation also enables Pro:Idiom decryption.

Note: The RF output from the HCS6300 can be combined with other channels in the site's distribution grid.

* Purchased separately.

Note: Design and specifications subject to change without prior notice.

Card Description

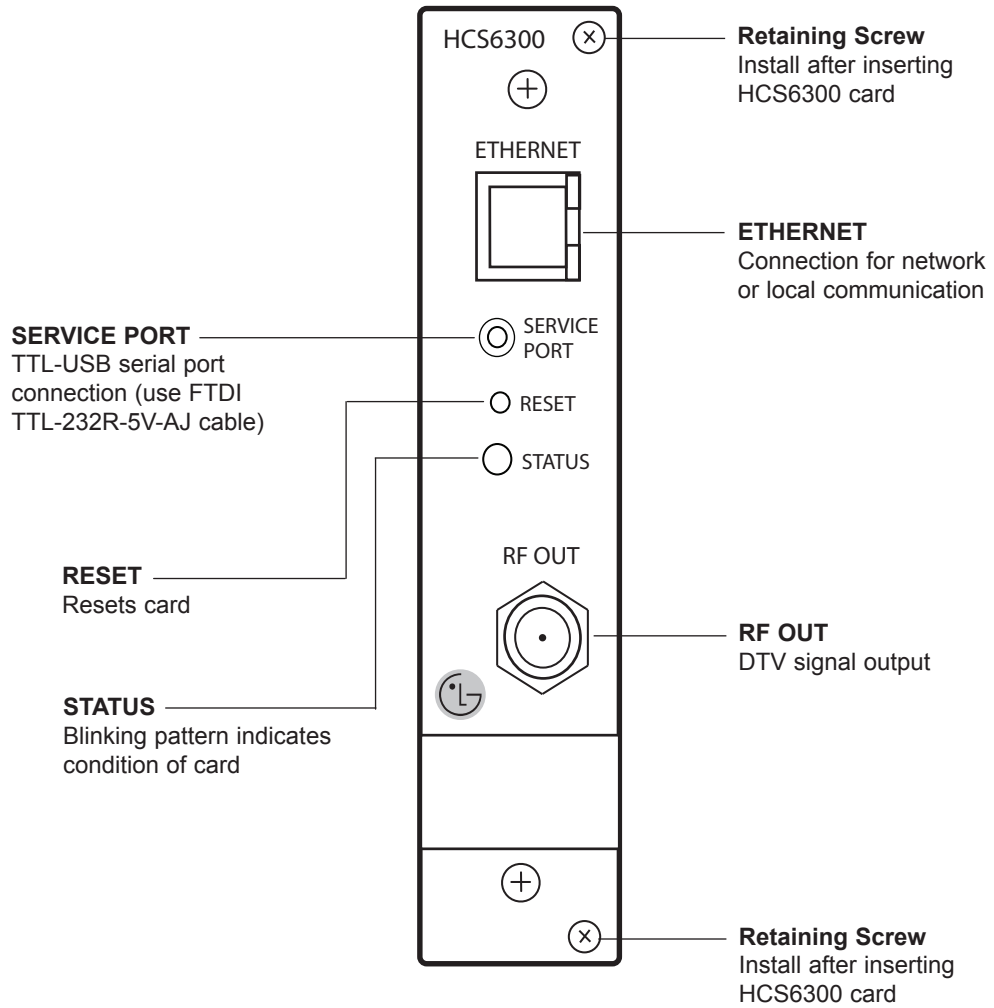

HCS6300 Functional Blocks

The HCS6300 consists of four main functional blocks:

- MUX: Four parallel multiplexers, each of which can combine up to two encrypted transport streams into a single 38 Mbps transport stream. The transport streams from the transcoder cards are supplied to the HCS6300 through the internal backplane circuit board of the card frame.
- MOD: Four parallel 256-QAM modulators that take the MUX output streams and produce four modulated outputs.
- Upconverter: This block takes the modulated output streams from the MOD block and places them on up to four contiguous cable RF channels. The output of this block is a combined RF signal four channels wide.
- Controller: Provides the PC interface for HCS6300 setup and configuration.

HCS6300 default settings assign the inputs of each channel MUX to specific slots in the CodePlus card frame, where the RF start channel is assigned to card frame Slots 1 & 2, the second channel is assigned to card frame Slots 4 & 5, etc.

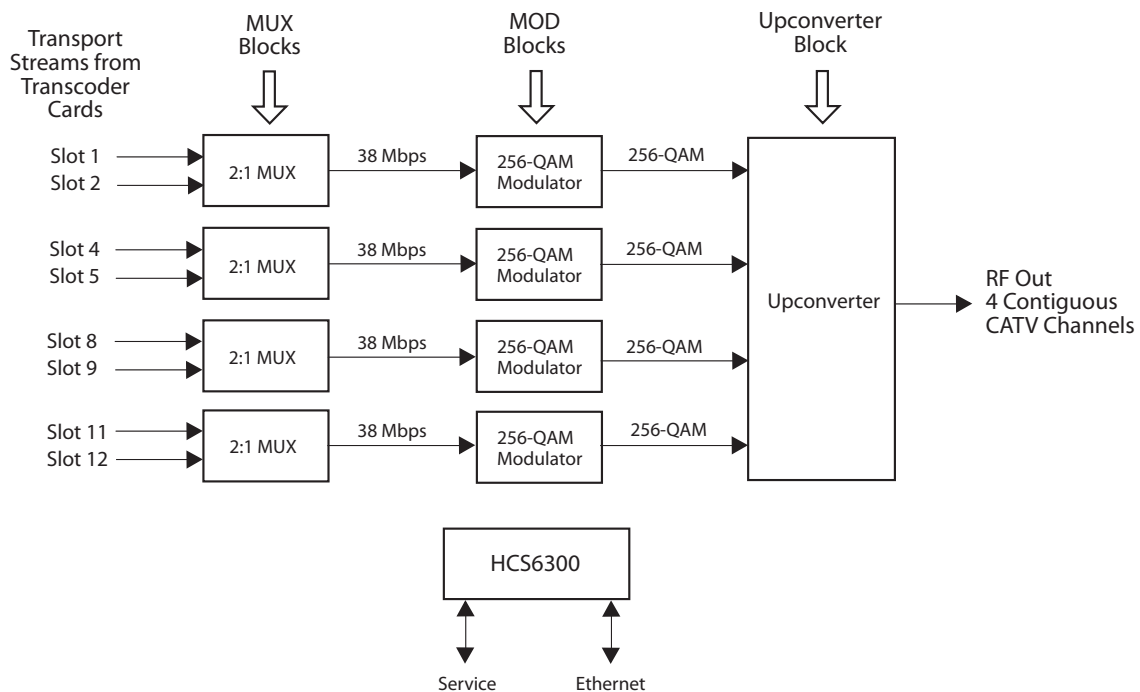

Installing a CodePlus Feature Card



Note: The CodePlus series products are NOT designed to be hot-swappable!!! Power must be removed to the card frame before any CodePlus transcoder cards are inserted or removed.



Note: All cards used in the card frame must be inserted and removed by qualified service personnel only.



Note: Use extreme care when handling an HCS6300 card. Always observe proper precautions with respect to static electricity and mechanical shock. When not installed in a card frame, return the HCS6300 card to the anti-static bag in which it was shipped.



Note: The card slots in the card frame are NOT all identical!!! An HCS6300 card can only be installed in the CONTROLLER slot. The connector arrangement of Slots 1 to 6 and 7 to 12 is incompatible with the HCS6300.



Note: When installing cards, remove blank cover plates and insert new cards as applicable. For ports that will not be used, leave the blank cover plates in place for proper ventilation and FCC and safety agency compliance.

Refer to the diagram on page 12, and follow the procedure below to install the CodePlus feature card.

1. Unpack the HCS6300 unit and the supplied HCS6400 fan card.

Note: If you are installing the HCS6300 in an HCS6150R card frame, an HCS6400 fan card is pre-installed in Slot 7. In this case, the HCS6400 fan card shipped with the HCS6300 is a spare.

2. Remove the AC power cord for the card frame from the power outlet.
3. Prepare the CONTROLLER slot in the card frame by removing either the blank cover plate or the CodePlus card currently in the slot. If installing in an HCS6100R card frame, also prepare Slot 7 for the HCS6400 fan card.
4. *Without using force*, slide the HCS6300 card into the CONTROLLER slot, and ensure that it is fully inserted. If applicable, then slide the HCS6400 fan card into Slot 7, and ensure that it is fully inserted.
5. Engage and tighten the top and bottom thumbscrews of the card(s) securely. Note that the thumbscrews should only be finger tight; overtightening may damage the assembly.
6. Refer to the diagram on page 13 for cabling connections, and complete the HCS6300 system installation procedure on page 14.

Installing a CodePlus Feature Card (Cont.)

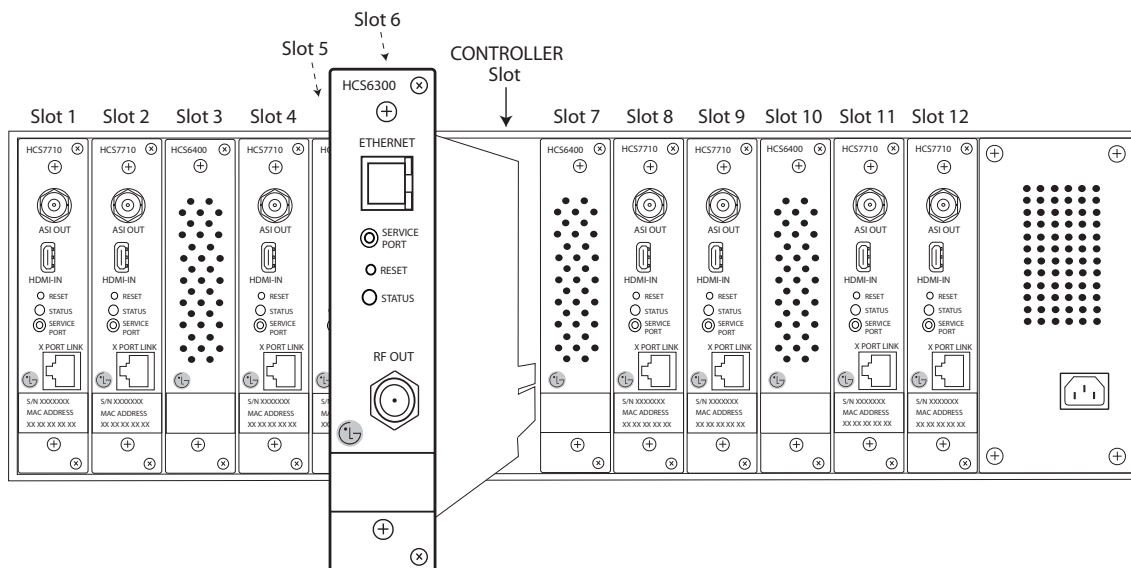

Satellite STB & HCS6300 Initialization & Setup Connections

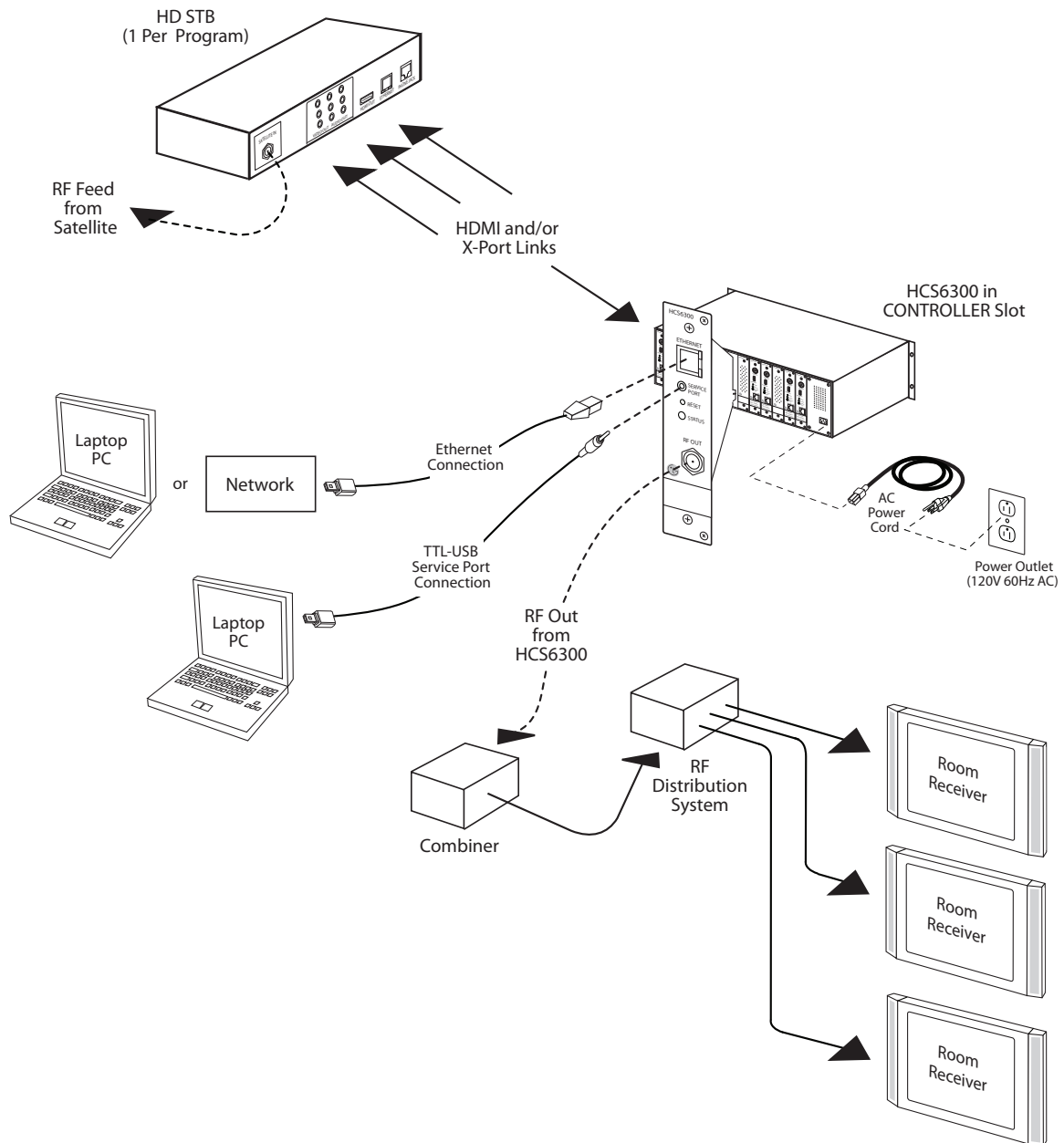

System Setup

Typical HCS6300 System Installation

(see also Typical Setup Flow Chart on the following page)

 **Note: ASI output is NOT required from transcoder cards for which modulator functionality is provided by the HCS6300. If additional transcoder cards are to be installed in Slots 3, 6, and/or 10 (HCS6700 transcoders in HCS6100R card frame only), refer to the Installation & Setup Guide for HCS6700 cards for further system setup information.**

1. Verify that the individual transcoder cards are installed and set up as described in the appropriate Installation & Setup Guide.
2. Plug in the power to the CodePlus card frame containing the newly installed feature card and transcoder card(s).
The green STATUS LED on the HCS6300 front panel will blink approximately once every second while the HCS6300 card boots up. The boot-up process for an HCS6300 may take up to one minute. When the boot-up is complete, the STATUS LED will be lit continuously.
3. Once the STATUS LED is lit continuously (no longer blinking), use the FTDI TTL-232R-5V-AJ cable to connect a PC to the HCS6300 Service Port.
4. Using HyperTerminal or an equivalent terminal emulation program on the PC, configure the serial port as follows: Bits per second/ baud = 115200; Data bits = 8; Parity = None; Stop bits = 1; Flow Control = None. Then, initiate communication with the HCS6300.
Once the connection is established, press **Enter** to refresh the screen and display the HCS6300 Main Menu.
5. Use the HCS6300 Main Menu “r” command, as described on page 32, to set the RF start channel for the HCS6300.
6. (Optional) For remote management purposes, you can connect the HCS6300 to an IP network and then use the Service Port connection to set the HCS6300 IP address:
 - a) Connect an Ethernet cable from the institution’s IP network to the HCS6300 ETHERNET port.
 - b) Use the HCS6300 Main Menu “setip” command, as described on page 34, to set the HCS6300 IP address.
7. Connect the HCS6300 RF OUT to the RF distribution system.
8. Check one or more room receivers to make sure all content is properly mapped and available.

System Setup (Cont.)

Typical Setup Flow Chart for HCS6300

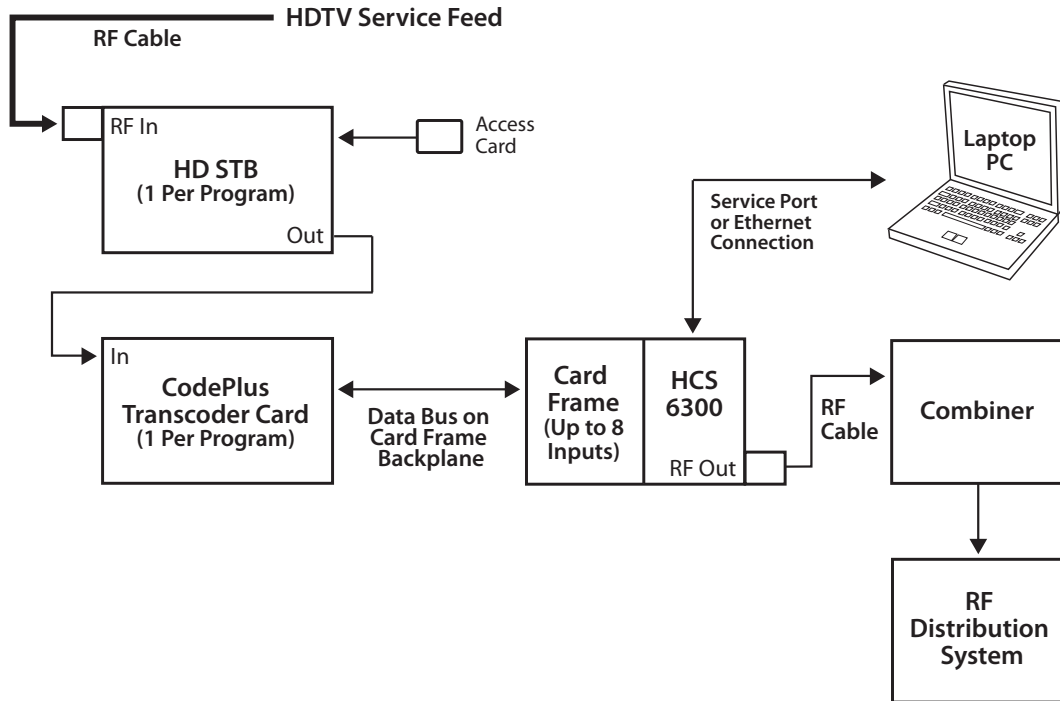

Network and Communication Setup

The HCS6300 feature card and the transcoder cards installed in the CodePlus card frame contain several internal registers for different configuration options. This document describes configuration options via a network or direct connection to the HCS6300.

Refer to the Installation & Setup Guide for the applicable transcoder cards for information on performing configuration via a direct connection to the transcoder Service Port.



Note: Before you proceed with any additional configuration, the system (including the feature card, transcoders, and satellite STBs) should be installed and operating as described in the Installation and Setup sections in this document.

There are three options for communicating with the HCS6300.

- When the HCS6300 is connected to an IP network, you can use a standard Internet browser to communicate with the HCS6300 via a graphical user interface (GUI).
- When the HCS6300 is connected to an IP network, you can also use Telnet to communicate with the HCS6300 via a command line interface.
- To establish a direct connection to the HCS6300, connect a PC to the serial port on the HCS6300 using the FTDI TTL-USB cable (P/N TTL-232R-5V-AJ). Plug the USB end of the cable into an open USB port on your PC. If necessary, install the device driver. Plug the other end of the cable into the Service Port jack on the HCS6300 front panel.

Using HyperTerminal or an equivalent terminal emulation program on the PC, configure the serial port as follows:

- Bits per second/baud = 115200
- Data bits = 8
- Parity = None
- Stop bits = 1
- Flow Control = None

Configuration options via web GUI are described on pages 17 to 30; configuration options via command line are described on pages 31 to 47. For security and control purposes, some options available from the command line menus are not available from the GUI.

Note: The default network setting for the HCS6300 is DHCP, in which case the server assigns an IP address to the HCS6300. If necessary, consult the network administrator to obtain the IP address that has been assigned to the HCS6300.

Note: If you want to connect the PC directly to the HCS6300 ETHERNET port using an Ethernet crossover cable, in order to establish communication you must first connect the PC to the HCS6300 Service Port, and set the HCS6300's IP address (see "Set the HCS6300 IP Address" on page 34). The HCS6300's IP address must be on the same subnet as the PC's IP address.

Configuration Options via GUI



Caution: Do NOT initiate simultaneous menu sessions to run commands. Doing so will interfere with active processes and may corrupt the system configuration and/or cause the HCS6300 card to cease normal operation.

Access the CodePlus Transcoder Series Web GUI

Note: The HCS6300 must be connected to an IP network for GUI access. See “Network and Communication Setup” on page 16 for further information.

1. Launch a web browser, and type **http://ipaddress** in the browser’s address bar, where *ipaddress* is the IP address of the HCS6300 card. Then, press **Enter**.

The CodePlus™ Transcoder Series Configuration Homepage provides access to Controller (HCS6300), Transcoder, and Satellite STB menus:

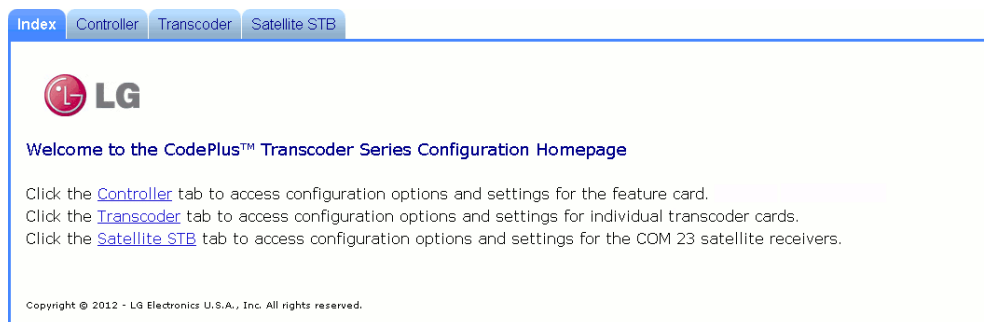

2. Click the appropriate link or tab to access the desired configuration options/settings.

The following sections provide detailed information on the configuration settings and commands. Note that menu options may vary from the examples shown in this document, depending on the HCS6300 firmware version.

When you have completed your activities in the web GUI, you can simply close your browser.

Controller Menu Commands

The following subsections describe how to access and use the Controller Menu commands.

Access the Controller Menu

1. Access the CodePlus Transcoder Series web GUI as described above.
2. With the Homepage on display, click on the **Controller** menu tab or link.

The Controller Menu (see example on following page) enables you to view and modify HCS6300 configuration settings and also enables you to view transcoder data. In addition, the Controller Menu enables you to update HCS6300 and transcoder card firmware.

Configuration Options via GUI (Cont.)

Example: Controller Menu

Copyright © 2012 - LG Electronics U.S.A., Inc. All rights reserved.

View HCS6300 System Information

With the Controller Menu on display, click on the **Read** button at the right of the System Information field to display HCS6300 hardware and software information.

The System Information display contains important information about the HCS6300, including the unit hardware ID (firmware version), software versions, IP address, MAC address, and serial number, for example:

System Information

```
Model:                HCS6300
Hardware ID:          6300-v1.7-2010-0715
OS version:           HCS6300-1084-2012-0112
Application version:  2.1
IP address:           10.166.60.84
MAC address:          00:0C:63:3a:00:07
Serial#:              901-12420014
```

It is recommended that you record this information for future reference. If you find it necessary to call customer service or engineering support, please have this information available.

Configuration Options via GUI (Cont.)

Set HCS6300 RF Channels

With the Controller Menu on display, type the appropriate RF start channel number in the data entry field at the right of the Set Start RF Channel field. Then, click on the **Set** button.

The remaining channels will be automatically assigned per EIA-542 STD CATV frequency allocation standards, and the system will display the channel assignments for the card slots (see example under “Read the RF Channel Map” below).

Read the RF Channel Map

With the Controller Menu on display, click on the **Read** button at the right of the Read RF Map field to display the current channel assignments, for example:

Channel Map:

```
-----+-----
Cards   | RF Channel
-----+-----
  1,  2 |      2
  4,  5 |      3
  8,  9 |      4
11, 12 |      5
-----+-----
```

Display a List of Transcoder Cards Installed in the Chassis

There are two options for listing transcoder cards installed in the chassis: one (List Cards) identifies the type of transcoder cards and the cards’ serial numbers, while the other (List Card Details) identifies the type of transcoder cards, along with the cards’ hardware and software version information. See sample displays below and on the following page.

With the Controller Menu on display, either click on the **List** button at the right of the List Cards field, or click on the **List** button at the right of the List Card Details field.

Example: List Cards Display

Available cards:

```
Card 1: [HCS7700] [001-12080022]
Card 2: [HCS7700] [001-12080023]
Card 3: [-]
Card 4: [HCS7700] [001-12080024]
Card 5: [HCS7700] [001-12080025]
Card 6: [-]
Card 7: [-]
Card 8: [HCS7700] [001-12080026]
Card 9: [HCS7700] [001-12080027]
Card 10: [-]
Card 11: [HCS7700] [001-12080028]
Card 12: [HCS7700] [001-12080029]
```

Configuration Options via GUI (Cont.)

Example: List Card Details Display

card#	card type	hardware id	os version	app	[enc]
1:	[HCS7700]	[7700-v2.3-2010-0715]	[HCS7700-738-2010-0716]	[2.0]	[1.1]
2:	[HCS7700]	[7700-v2.3-2010-0715]	[HCS7700-738-2010-0716]	[2.0]	[1.1]
3:	[-]				
4:	[HCS7700]	[7700-v2.3-2010-0715]	[HCS7700-738-2010-0716]	[2.0]	[1.1]
5:	[HCS7700]	[7700-v2.3-2010-0715]	[HCS7700-738-2010-0716]	[2.0]	[1.1]
6:	[-]				
7:	[-]				
8:	[HCS7700]	[7700-v2.3-2010-0715]	[HCS7700-738-2010-0716]	[2.0]	[1.1]
9:	[HCS7700]	[7700-v2.3-2010-0715]	[HCS7700-738-2010-0716]	[2.0]	[1.1]
10:	[-]				
11:	[HCS7700]	[7700-v2.3-2010-0715]	[HCS7700-738-2010-0716]	[2.0]	[1.1]
12:	[HCS7700]	[7700-v2.3-2010-0715]	[HCS7700-738-2010-0716]	[2.0]	[1.1]

View MUX or Raw Bitrate Data

Bitrate data is useful for system monitoring and troubleshooting purposes. Bitrates at the backplane (raw bitrates), are measured at the input pins prior to data processing. MUX bitrates provide information on MUX data processing, i.e., the amount of data filtering in and out of the MUX. See sample displays below and on the following page.

With the Controller Menu on display, either:

- Click on the **Read** button at the right of the Read Bitrates at Backplane field to view raw bitrate data for each installed transcoder card (including any transcoders in Slots 3, 6, and/or 10).
- Click on the **Read** button at the right of the Read MUX Bitrates field to view MUX bitrate data for each HCS6300-controlled transcoder.

Example: Bitrates at Backplane Connector (Raw Bitrates) Display

Slot #1	Raw bitrate data 14.228 Mbit/s total 19.396 Mbit/s	Total number of data bits that are not null packets
Slot #2	Raw bitrate data 12.537 Mbit/s total 19.390 Mbit/s	
Slot #3	Raw bitrate data 0 total 0	Total number of data bits in the transport stream
Slot #4	Raw bitrate data 17.049 Mbit/s total 19.390 Mbit/s	
Slot #5	Raw bitrate data 15.503 Mbit/s total 19.396 Mbit/s	
Slot #6	Raw bitrate data 0 total 0	
Slot #7	Raw bitrate data 0 total 0	
Slot #8	Raw bitrate data 13.536 Mbit/s total 19.390 Mbit/s	
Slot #9	Raw bitrate data 13.957 Mbit/s total 19.396 Mbit/s	
Slot #10	Raw bitrate data 0 total 0	
Slot #11	Raw bitrate data 7.520 Mbit/s total 19.396 Mbit/s	
Slot #12	Raw bitrate data 18.620 Mbit/s total 19.396 Mbit/s	

Configuration Options via GUI (Cont.)

Example: MUX Bitrates Display

Slot #1 Bitrate 19.035 Mbit/s (unfiltered 19.065 Mbit/s)
 Slot #2 Bitrate 12.658 Mbit/s (unfiltered 12.694 Mbit/s)
 Mux #1 Output Bitrate 31.746 Mbit/s

Slot #4 Bitrate 19.335 Mbit/s (unfiltered 19.359 Mbit/s)
 Slot #5 Bitrate 14.679 Mbit/s (unfiltered 14.715 Mbit/s)
 Mux #2 Output Bitrate 34.051 Mbit/s

Slot #8 Bitrate 13.013 Mbit/s (unfiltered 13.049 Mbit/s)
 Slot #9 Bitrate 13.903 Mbit/s (unfiltered 13.933 Mbit/s)
 Mux #3 Output Bitrate 26.970 Mbit/s

Slot #11 Bitrate 6.269 Mbit/s (unfiltered 6.305 Mbit/s)
 Slot #12 Bitrate 18.583 Mbit/s (unfiltered 18.614 Mbit/s)
 Mux #4 Output Bitrate 24.900 Mbit/s

Per Mux Total Output Bitrate 38.815 Mbit/s

Data currently in use by the MUX

Unprocessed data

Data currently output by the MUX

Total amount of data (including null packets) output per RF channel

Configure Card Number/Channel Assignments

This option enables you to reconfigure the card number/channel assignments.

1. With the Controller Menu on display, click on the **Edit** button at the right of the Card/Channel Assignment field.
2. In the Configure Card Number to Channel Assignment window, click on the down arrow at the right each Card Number field you wish to reassign, and select from the drop-down list of options the appropriate card number or N/C (no connection) for the RF channel listed in the Channel column.

Configure Card Number to Channel Assignment

Channel	Card Number
54-1	1 ▼
54-2	2 ▼
55-1	4 ▼
55-2	5 ▼
56-1	8 ▼
56-2	9 ▼
57-1	11 ▼
57-2	12 ▼

3. When you have completed the assignments, click on the **Save Configuration** button below the Assignment table.

(Continued on next page)

Configuration Options via GUI (Cont.)

(Continued from previous page)

The system will display the New Channel Map, for example:

New Channel Map:

RF	Card Slot
54-1	1
54-2	2
55-1	11
55-2	12
56-1	8
56-2	9
57-1	4
57-2	5

Set the HCS6300 IP Address

1. With the Controller Menu on display, click on the **Set** button at the right of the Set IP Address field.
2. In the Set IP Address window:
 - Select the DHCP Mode setting—Enable or Disable—by clicking the radio button at the left of the appropriate option.
 - If you wish to specify static IP information (i.e., DHCP will be disabled), type the appropriate data in the IP Address, Subnet Mask, and Default Gateway fields.

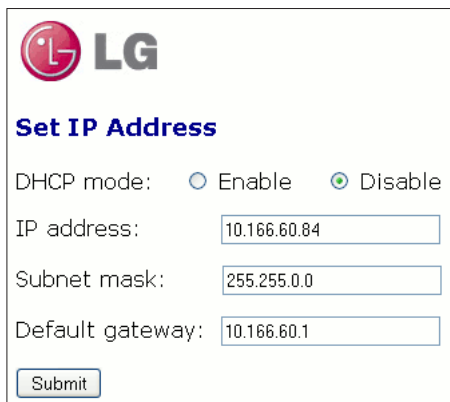

(Continued on next page)

Configuration Options via GUI (Cont.)

(Continued from previous page)

3. Click on the **Submit** button when you are ready to continue.

The system will display an overview of the settings and then prompt you to reset the HCS6300, for example:

```
DHCP mode selected
```

```
Reset the Controller card to activate new IP settings.
```

or

```
Static IP mode selected
```

```
IP address:           xxx.xxx.xxx.xxx
```

```
Subnet mask:         xxx.xxx.xxx.xxx
```

```
Default gateway:    xxx.xxx.xxx.xxx
```

```
Reset the Controller card to activate new IP settings.
```

4. If you are ready to reset the HCS6300 immediately, click on the **Reset** button located below the results text.

Note: If you intend to modify additional configuration settings during the current session, you may wait until all changes are complete before you reset the HCS6300 (see “Perform an External Card Reset” on page 24 for further information); however, note that IP settings will not take effect until the HCS6300 resets.

Change the (Reload Pro:Idiom Key) Password

This option enables you to change the password required to reload the Pro:Idiom key on selected transcoders. The default password is “service”.

1. With the Controller Menu on display, click on the **Change** button at the right of the Change (Reload P:I Key) Password field.

The system will initiate a series of password prompts in pop-up windows.

2. At the `Enter the Current Password` prompt, type the current password and click **OK**.
3. At the `Enter New Password` prompt, type the new password and click **OK**.
4. At the `Confirm New Password` prompt, retype the new password and click **OK**.

When the password is successfully changed, the system will display confirmation, for example:

```
Password changed.
```

Configuration Options via GUI (Cont.)

Update HCS6300 and/or Transcoder Firmware via TFTP

If you are not sure of the current firmware version, view and record the System Information for the HCS6300 and/or the transcoder card(s) before you initiate the firmware update. See “View HCS6300 System Information” on page 18 and/or “View Hardware Information for a Selected Transcoder” on page 25, as necessary.

The firmware update requires that you set up a TFTP server on the same IP network as the HCS6300. Consult the network administrator, as necessary, for further information.



Caution: Do NOT initiate simultaneous menu sessions while a firmware update is in progress. Doing so will interfere with the active processes and may corrupt the system configuration and/or cause the HCS6300 card to cease normal operation.

1. Make sure the firmware update configuration (.cfg) and package (.pkg) files are available on the same machine as the TFTP server. Then, set up the TFTP server, and point to the directory in which the firmware update files are located.
2. With the Controller Menu on display, select the card or cards to which to download firmware: Click on the down arrow at the right of the Card Select field, and select the appropriate option from the drop-down list. You can update firmware on a single transcoder (select the appropriate card number), the Controller (HCS6300), or all transcoder cards.
3. Type the IP address for the TFTP server in the TFTP Server IP Address field and the name of the configuration file in the format “*filename.cfg*” in the Software Update File Name field. Then, click **Update**. This will initiate the installation of both the configuration and package files.

Note: If you wish to check the status of the firmware update while in progress, click on the **Status** button at the right of the Update field.

4. When the firmware update is successfully completed, initiate a reset of ALL the cards that received the firmware update (see “Perform an External Card Reset” below).

Perform an External Card Reset

This option enables you to reset a single transcoder, the Controller (HCS6300), or all transcoder cards.

1. With the Controller Menu on display, select the card or cards to reset: Click on the down arrow at the right of the Card Select field, and select the appropriate option from the drop-down list.
2. Click on the **Reset** button at the right of the Card Reset field.

The system will display confirmation before initiating the reset of the selected card(s), for example:

```
Success. Reset command sent to card 2.
```

Configuration Options via GUI (Cont.)

Transcoder Menu Commands

The following subsections describe how to access and use the Transcoder Menu commands.

Access the Transcoder Menu

1. Access the CodePlus Transcoder Series web GUI as described on page 17.
2. With the Homepage on display, click on the **Transcoder** menu tab or link.

The Transcoder Menu (see example below) enables you to view and modify selected transcoder card configuration settings.

Example: Transcoder Menu

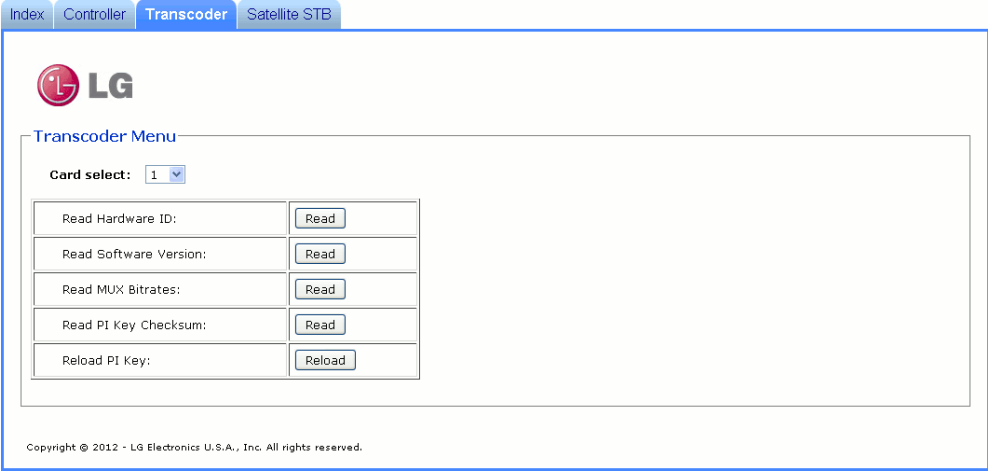

Transcoder Menu	
Card select:	1
Read Hardware ID:	Read
Read Software Version:	Read
Read MUX Bitrates:	Read
Read PI Key Checksum:	Read
Reload PI Key:	Reload

Copyright © 2012 - LG Electronics U.S.A., Inc. All rights reserved.

View Hardware Information for a Selected Transcoder

1. With the Transcoder Menu on display, click on the down arrow at the right of the Card Select field, and select the appropriate transcoder card from the drop-down list of options.
2. Click on the **Read** button at the right of the Read Hardware ID field to view the selected card's hardware ID (firmware version), for example:

Card 1:

Card HWID# is: 7700-v2.3-2010-0715

Configuration Options via GUI (Cont.)

View Software Information for a Selected Transcoder

1. With the Transcoder Menu on display, click on the down arrow at the right of the Card Select field, and select the appropriate transcoder card from the drop-down list of options.
2. Click on the **Read** button at the right of the Read Software Version field to view the selected card's software versions, for example:

```
Card 1:  
OS version:      HCS7700-738-2010-0716  
Encoder version: 1.1  
Ethernet version: 1.0  
Application version: 2.0
```

View MUX Bitrate Data for a Selected Transcoder

1. With the Transcoder Menu on display, click on the down arrow at the right of the Card Select field, and select the appropriate transcoder card from the drop-down list of options.
2. Click on the **Read** button at the right of the Read MUX Bitrates field to view MUX bitrate data (displayed in millions of bits per second [Mbit/s]) for the selected transcoder card, for example:

```
Card 1:  
Ethernet Input Bitrate: 3.826 Mbit/s (raw 3.838 Mbit/s)  
Data Output Bitrate: 4.127 Mbit/s  
Total Output Bitrate: 19.390 Mbit/s
```

The example above shows MUX bitrate data for an HCS6700 card. An HCS7700 or HCS7710 MUX bitrate display will show HDMI Input bitrate data in addition to Ethernet Input bitrate data. Refer to the Installation & Setup Guide for the applicable transcoder cards for further information on bitrate data.

View the Pro:Idiom Key Checksum

1. With the Transcoder Menu on display, click on the down arrow at the right of the Card Select field, and select the appropriate transcoder card from the drop-down list of options.
2. Click on the **Read** button at the right of the Read PI Key Checksum field to display the Pro:Idiom key checksum for the selected transcoder, for example:

```
Card 1:  
PI key checksum is xxxxxxxxxxxx
```

where xxxxxxxxxxxx is a 10-digit number that identifies the Pro:Idiom key file installed on the transcoder.



Note: All transcoder cards in the card frame must have the same Pro:Idiom key file installed.

Configuration Options via GUI (Cont.)

Reload the Pro:Idiom Key on a Selected Transcoder

This command reloads the Pro:Idiom encryption key on a single transcoder card. Note that a password is required to initiate this command.

1. With the Transcoder Menu on display, click on the down arrow at the right of the Card Select field, and select the appropriate transcoder card from the drop-down list of options.
2. Click on the **Reload** button at the right of the Reload PI Key field.
3. At the pop-up window prompt for the password required to execute the operation, type the password and click **OK**.

When the reload is complete, the system will display confirmation, for example:

```
Card 1:  
Reloading the key ...  
Successfully reloaded PI key
```

Satellite STB Menu Commands

The following subsections describe how to access and use the Satellite STB Menu commands.

Access the Satellite STB Menu

1. Access the CodePlus Transcoder Series web GUI as described on page 17.
2. With the Homepage on display, click on the **Satellite STB** menu tab or link.

The Satellite STB Menu (see example on following page) enables you to view and modify selected satellite STB configuration settings.

Set the STB Channel

1. With the Satellite STB Menu on display, click on the down arrow at the right of the Card Select field, and select the appropriate card from the drop-down list of options.
2. Type the desired three-digit channel number in the Set Channel field, and then click on the **Set** button at the right of the entry field.

If the channel is set successfully, the satellite STB will change to the specified DIRECTV channel and the system will display confirmation, for example:

```
Card 1: Channel changed to 209
```

Configuration Options via GUI (Cont.)

Example: Satellite STB Menu

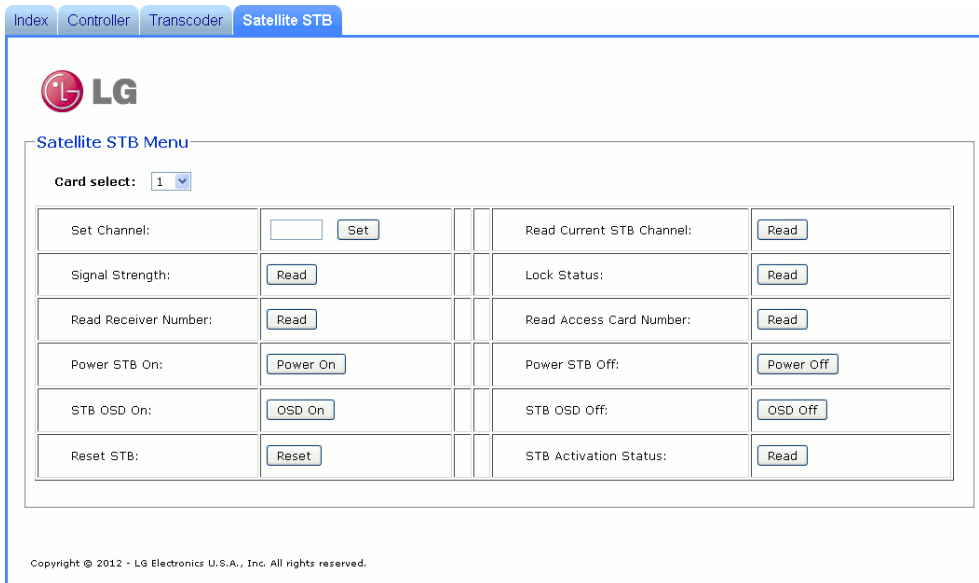

Read the Current STB Channel

1. With the Satellite STB Menu on display, click on the down arrow at the right of the Card Select field, and select the appropriate transcoder card from the drop-down list of options.
2. Click on the **Read** button at the right of the Read Current STB Channel field to display the currently selected satellite STB channel number, for example:

Card 1: Current STB Channel is 209

If you receive an error message, it may be necessary to reset the satellite STB either using the “Reset STB” command described on page 30 or using the RESET button on the satellite STB front panel.

Read the Satellite Signal Strength

1. With the Satellite STB Menu on display, click on the down arrow at the right of the Card Select field, and select the appropriate transcoder card from the drop-down list of options.
2. Click on the **Read** button at the right of the Signal Strength field to display the satellite signal strength (displayed as a percentage) at the Satellite In jack on the satellite STB, for example:

Card 1: Satellite signal strength is 52%

Configuration Options via GUI (Cont.)

Read the Satellite Lock Status

1. With the Satellite STB Menu on display, click on the down arrow at the right of the Card Select field, and select the appropriate transcoder card from the drop-down list of options.
2. Click on the **Read** button at the right of the Lock Status field to determine whether or not the satellite receiver is locked to the satellite, for example:

Card 1: Satellite signal is locked

Read the STB Serial Number

1. With the Satellite STB Menu on display, click on the down arrow at the right of the Card Select field, and select the appropriate transcoder card from the drop-down list of options.
2. Click on the **Read** button at the right of the Read Receiver Number field to display the satellite STB serial number, for example:

Card 1: STB serial number is 029265702091

Read the Access Card Number

1. With the Satellite STB Menu on display, click on the down arrow at the right of the Card Select field, and select the appropriate transcoder card from the drop-down list of options.
2. Click on the **Read** button at the right of the Read Access Card Number field to display the satellite STB access card serial number, for example:

Card 1: Access card serial number is 002468525676

Power the STB On or Off

Power On and Power Off options in the Satellite STB Menu enable you to power ON a satellite STB from standby mode or power OFF a satellite STB to standby mode.

1. With the Satellite STB Menu on display, click on the down arrow at the right of the Card Select field, and select the appropriate transcoder card from the drop-down list of options.
2. Either:

- Click on the **Power On** button at the right of the Power Tuner On field to power ON the satellite STB.

The system will display confirmation, for example:

Card 1: STB Powered On

- Click on the **Power Off** button at the right of the Power Tuner Off field to switch the satellite STB to standby mode. HDMI output is disabled, but the Ethernet port continues to stream audio and video.

The system will display confirmation, for example:

Card 1: STB Powered Off

Configuration Options via GUI (Cont.)

Set the Satellite OSD On or Off

1. With the Satellite STB Menu on display, click on the down arrow at the right of the Card Select field, and select the appropriate transcoder card from the drop-down list of options.
2. Either:
 - Click on the **OSD On** button at the right of the STB OSD On field to enable on-screen display for the video signal at the HDMI output.
 - Click on the **OSD Off** button at the right of the STB OSD Off field to disable on-screen display for the video signal at the HDMI output. Note that the Ethernet video stream does not contain on-screen display.

Reset the Satellite STB

1. With the Satellite STB Menu on display, click on the down arrow at the right of the Card Select field, and select the appropriate transcoder card from the drop-down list of options.
2. Click on the **Reset** button at the right of the Reset STB field to reset the satellite STB.

The system displays confirmation, for example:

```
Card 1: The STB is resetting...
```

After reset, the satellite STB resumes normal operation.

Read the STB Activation Status

1. With the Satellite STB Menu on display, click on the down arrow at the right of the Card Select field, and select the appropriate transcoder card from the drop-down list of options.
2. Click on the **Read** button at the right of the STB Activation Status field to display the activation status—activated or not activated—of the satellite STB.

Configuration Options via Command Line



Caution: Do NOT initiate simultaneous menu sessions to run commands. Doing so will interfere with active processes and may corrupt the system configuration and/or cause the HCS6300 card to cease normal operation.

Access the HCS6300 Main Menu

Note: The HCS6300 must be connected to an IP network for Telnet access. For direct access to the HCS6300 Service Port, use the FTDI TTL-USB cable (P/N TTL-232R-5V-AJ). See also “Network and Communication Setup” on page 16 for further information.

1. Establish communication with the HCS6300 using Telnet or via a direct connection to the HCS6300 Service Port.
2. Once communication is established, press **Enter** to refresh the menu display in the terminal. You now have access to the HCS6300 configuration Main Menu (see example below).
3. At the [Main] Command > prompt, type the desired menu command and press **Enter**.

Note: You can always press **Enter** at the [Main] Command > prompt to display the HCS6300 Main Menu. Main Menu options may vary from the example shown, depending on the HCS6300 firmware version.

The following sections describe the configuration commands.

Example: HCS6300 Main Menu

```
-----  
Main Menu      (Copyright 2012 - LGE USA)  
-----  
  
info      System Information  
rf        Set RF Channels  
mrf       Print RF Channels Map  
list      List Cards  
card      Card Menu  
xrst      External Card Reset  
setip     Set Up IP Address  
pi        Install PI Key On All Cards  
pr        Reload PI Key on All Cards  
upd       Update Firmware  
bits      Read MUX Bitrates  
rawbits   Read Bitrates at Backplane Connector  
crosspt   Configure Card Number to Channel Assignment  
rstpwd    Reset Password (for Reload PI Key on Web UI)  
  
[Main] Command >
```

Configuration Options via Command Line (Cont.)

View HCS6300 System Information

1. Access the HCS6300 Main Menu as described on the previous page.
2. At the [Main] Command > prompt, type **info** and press **Enter** to display HCS6300 hardware and software information.

The System Information display contains important information about the HCS6300, including the unit hardware ID (firmware version), software versions, IP address, MAC address, and serial number, for example:

```
System Information
-----
Model:                HCS6300
Hardware ID:          6300-v1.7-2010-0715
OS version:           HCS6300-1084-2012-0112
Application version:  2.1
IP address:           10.166.60.84
MAC address:          00:0C:63:3a:00:07
Serial#:              901-12420014
```

It is recommended that you record this information for future reference. If you find it necessary to call customer service or engineering support, please have this information available.

Set HCS6300 RF Channels

1. Access the HCS6300 Main Menu as described on the previous page.
2. At the [Main] Command > prompt, type **rf** and press **Enter**.
3. At the Enter the start channel number [2 - 132] > prompt, type the appropriate start channel number and press **Enter**.

The remaining channels will be automatically assigned per EIA-542 STD CATV frequency allocation standards, and the system will display the channel assignments (i.e., the Channel Map) for the card slots (see example under "Print the RF Channel Map" below).

Print the RF Channel Map

1. Access the HCS6300 Main Menu as described on the previous page.
2. At the [Main] Command > prompt, type **mrf** and press **Enter** to display the current Channel Map, for example:

```
Channel Map:
-----+-----
Cards   | RF Channel
-----+-----
  1,  2 |         2
  4,  5 |         3
  8,  9 |         4
 11, 12 |         5
-----+-----
```

Configuration Options via Command Line (Cont.)

Display a List of Transcoder Cards Installed in the Chassis

1. Access the HCS6300 Main Menu as described on page 31.
2. At the `[Main] Command >` prompt, type **list** and press **Enter**.

The display identifies the type of transcoder cards installed and their serial numbers, for example:

```
Available cards:
Card  1: [HCS7700] [001-12080022]
Card  2: [HCS7700] [001-12080023]
Card  3: [-]
Card  4: [HCS7700] [001-12080024]
Card  5: [HCS7700] [001-12080025]
Card  6: [-]
Card  7: [-]
Card  8: [HCS7700] [001-12080026]
Card  9: [HCS7700] [001-12080027]
Card 10: [-]
Card 11: [HCS7700] [001-12080028]
Card 12: [HCS7700] [001-12080029]
```

Access Individual Transcoder Menus

See “Transcoder Menu Commands” on pages 40 to 43 for detailed information on transcoder configuration options.

Perform an External Card Reset

1. Access the HCS6300 Main Menu as described on page 31.
2. At the `[Main] Command >` prompt, type **xrst** and press **Enter**.
3. At the `Enter card number (1-12, 'ctr', or 'all') >` prompt, either:
 - Type the slot number of the card and press **Enter** to reset a single transcoder card.
 - Type **all** and press **Enter** to reset each of the transcoder cards (including any transcoders in Slots 3, 6, and/or 10).
 - Type **ctr** and press **Enter** to reset the HCS6300.

If you opt to reset one or more of the transcoder cards, the system will display confirmation before resetting the selected card(s), for example:

```
Resetting card 5:
```

If you opt to reset the HCS6300, the system will initiate the reset immediately without further confirmation.

Configuration Options via Command Line (Cont.)

Set the HCS6300 IP Address

1. Access the HCS6300 Main Menu as described on page 31.
2. At the [Main] Command > prompt, type **setip** and press **Enter**.
3. At the Using DHCP (y/n)? prompt, either:
 - Type **y** and press **Enter** if using DHCP. The system will display: IP address has been set.
Go to step 5.
 - Type **n** and press **Enter** to assign a static IP address to the HCS6300. Then, continue with step 4.
4. At each of the following prompts, type the information requested. Press **Enter** after each entry.
Enter IP address: *(Type the host IP address in the format xxx.xxx.xxx.xxx.)*
Enter Subnet Mask: *(Type the subnet mask in the format xxx.xxx.xxx.xxx.)*
Enter Gateway: *(Type the IP address of the default gateway in the format xxx.xxx.xxx.xxx.)*
Once you enter the gateway address, the system will display: IP address has been set.
5. Reset the HCS6300 card (see “Perform an External Card Reset” on page 33). IP settings will not take effect until the HCS6300 resets.
Note: If you intend to modify additional configuration settings during the current session, you may wait until all changes are complete before you reset the HCS6300.

Install a Pro:Idiom Key on All Transcoders

The Pro:Idiom encrypter built into the transcoder cards contains a default encryption key. When first installed, the cards will use this key to encrypt content. This command enables you to change the encryption key, if necessary.

This command installs the Pro:Idiom key on all the transcoders installed in the chassis (including any transcoders in Slots 3, 6, and/or 10). To install a Pro:Idiom key on a single transcoder, see “Install a Pro:Idiom Key on the Selected Transcoder” on page 41.



Note: In order for a Pro:Idiom encrypted channel to be displayed, the receiver must contain a Pro:Idiom decrypter, and the receiver must be configured to allow decryption of the desired channel.



Note: The process of updating the encryption key will synchronize the decryption key in any receiver tuned to the cards’ output. If the target receiver is turned off or viewing content from a different card, the synchronization will not occur, and the output will be scrambled. Ensure that all encrypters and decrypters in a system are synchronized to the same key.

(Continued on next page)

Configuration Options via Command Line (Cont.)

(Continued from previous page)



Caution: Do NOT initiate simultaneous menu sessions while a Pro:Idiom key installation is in progress. Doing so will interfere with the active processes and may corrupt the system configuration and/or cause the HCS6300 card to cease normal operation.

1. Confirm the directory location of the Pro:Idiom key (.hex) file. Note: For a TFTP file transfer, the key file must be available on the same machine as the TFTP server.
2. Access the HCS6300 Main Menu as described on page 31.
3. At the `[Main] Command >` prompt, type **pi** and press **Enter**.
4. At the `Use TFTP to download key (y/n)?` prompt, either:
 - Type **y** and press **Enter** to use TFTP for the Pro:Idiom key installation.
 - Type **n** and press **Enter** if you will not use TFTP for the Pro:Idiom key installation. At the next system prompt: `Use XMODEM to transfer files (y/n)?`, type **y** and press **Enter**.
5. Refer to the appropriate subsection below, depending on the file transfer option used.

Xmodem File Transfer

The system will request a key file. Transfer the new Pro:Idiom key file using Xmodem protocol.

For example, in HyperTerminal, select **Transfer** and then **Send File....** In the Send File window, enter or select the appropriate Pro:Idiom key file in the Filename field, and select **Xmodem** in the Protocol field.

TFTP Transfer

The HCS6300 must be connected to an IP network for a TFTP transfer. TFTP transfer also requires that you set up a TFTP server on the same IP network as the HCS6300. Consult the network administrator, as necessary, for further information.

- a) Make sure the key file is available on the same machine as the TFTP server. Then, set up the TFTP server, and point to the directory in which the Pro:Idiom key file is located. Note the name of the Pro:Idiom key file; you will need it to initiate the transfer.
- b) At the `Enter TFTP server IP` prompt, type the IP address for the TFTP server and press **Enter**, or simply press **Enter** if the default IP address shown in square brackets is correct.
- c) At the `Enter the PI key file name` prompt, type the name of the Pro:Idiom key file in the format "*filename*.hex" and press **Enter**.

The system will display progress messages as well as the result of the installation process. Note that the new key will be stored in non-volatile storage regardless of process results.

Configuration Options via Command Line (Cont.)

Reload the Pro:Idiom Key on All Transcoders

This command reloads the Pro:Idiom encryption key on all the transcoders installed in the chassis (including any transcoders in Slots 3, 6, and/or 10). To reload the Pro:Idiom key on a single transcoder, see “Reload the Pro:Idiom Key on the Selected Transcoder” on page 42.

1. Access the HCS6300 Main Menu as described on page 31.
2. At the `[Main] Command >` prompt, type **pr** and press **Enter**.
3. At the `Reload PI key. Continue (y/n)?` prompt, type **y** and press **Enter** to continue.

When the reload is complete, the system will display confirmation:

```
Reload PI complete OK
```

Update HCS6300 and/or Transcoder Firmware

If you are not sure of the current firmware version, view and record the System Information for the HCS6300 and/or the transcoder card(s) before you initiate the firmware update. See “View HCS6300 System Information” on page 32 and/or “View Hardware Information for the Selected Transcoder” on page 41, as necessary.

 **Caution: Do NOT initiate simultaneous menu sessions while a firmware update is in progress. Doing so will interfere with the active processes and may corrupt the system configuration and/or cause the HCS6300 card to cease normal operation.**

1. Confirm the directory location of the required firmware update configuration (.cfg) and package (.pkg) files. Note: For a TFTP file transfer, the firmware update files must be available on the same machine as the TFTP server.
2. Access the HCS6300 Main Menu as described on page 31.
3. At the `[Main] Command >` prompt, type **upd** and press **Enter**.
4. At the `Enter card number (1-12, 'ctr', or 'all') >` prompt, either:
 - Type the slot number of the card and press **Enter** to update a single transcoder card.
 - Type **all** and press **Enter** to update each of the transcoder cards (including any transcoders in Slots 3, 6, and/or 10).
 - Type **ctr** and press **Enter** to update the HCS6300 firmware.
5. At the `Use TFTP to transfer files (y/n)?` prompt, either:
 - Type **y** and press **Enter** to use TFTP for the firmware update.
 - Type **n** and press **Enter** if you will not use TFTP for the firmware update. At the next system prompt: `Use XMODEM to transfer files (y/n)?`, type **y** and press **Enter**.
6. Refer to the appropriate subsection below, depending on the file transfer option used.

(Continued on next page)

Configuration Options via Command Line (Cont.)

(Continued from previous page)

Xmodem File Transfer

- a) The system will request a configuration (.cfg) file. Transfer the new configuration file using Xmodem protocol.

For example, in HyperTerminal, select **Transfer** and then **Send File...** In the Send File window, enter or select the appropriate configuration file in the Filename field, and select **Xmodem** in the Protocol field.

- b) Upon receipt of the configuration file, the system will request a package (.pkg) file. Transfer the package file using Xmodem protocol.

TFTP Transfer

The HCS6300 must be connected to an IP network for a TFTP transfer. TFTP transfer also requires that you set up a TFTP server on the same IP network as the HCS6300. Consult the network administrator, as necessary, for further information.

- a) Make sure the firmware update files are available on the same machine as the TFTP server. Then, set up the TFTP server, and point to the directory in which the firmware update files are located.

Note the name of the configuration file; you will need it to initiate the transfer.

- b) At the `Enter TFTP server IP` prompt, type the IP address for the TFTP server and press **Enter**, or simply press **Enter** if the default IP address shown in square brackets is correct.
- c) At the `Enter the config file name` prompt, type the name of the configuration file in the format "*filename.cfg*" and press **Enter**. This will initiate the installation of both the configuration and package files.

7. The system will display progress messages as well as the result of the update process (which may take several minutes). When the firmware update is successfully completed, initiate a reset of ALL the cards that received the firmware update (see "Perform an External Card Reset" on page 33).

View MUX or Raw Bitrate Data

Bitrate data is useful for system monitoring and troubleshooting purposes. MUX bitrates provide information on MUX data processing, i.e., the amount of data filtering in and out of the MUX. Raw bitrates are measured at the input pins prior to data processing.

1. Access the HCS6300 Main Menu as described on page 31.
2. At the `[Main] Command >` prompt, either:
 - Type **bits** and press **Enter** to view MUX bitrate data for each HCS6300-controlled transcoder. See example on following page.
 - Type **rawbits** and press **Enter** to view raw bitrate data for each installed transcoder card (including any transcoders in Slots 3, 6, and/or 10). See example on following page.

Configuration Options via Command Line (Cont.)

Example: MUX Bitrates Display

```
Slot #1 Bitrate 19.035 Mbit/s (unfiltered 19.065 Mbit/s)
Slot #2 Bitrate 12.658 Mbit/s (unfiltered 12.694 Mbit/s)
Mux #1 Output Bitrate 31.746 Mbit/s
Slot #4 Bitrate 19.335 Mbit/s (unfiltered 19.359 Mbit/s)
Slot #5 Bitrate 14.679 Mbit/s (unfiltered 14.715 Mbit/s)
Mux #2 Output Bitrate 34.051 Mbit/s
Slot #8 Bitrate 13.013 Mbit/s (unfiltered 13.049 Mbit/s)
Slot #9 Bitrate 13.903 Mbit/s (unfiltered 13.933 Mbit/s)
Mux #3 Output Bitrate 26.970 Mbit/s
Slot #11 Bitrate 6.269 Mbit/s (unfiltered 6.305 Mbit/s)
Slot #12 Bitrate 18.583 Mbit/s (unfiltered 18.614 Mbit/s)
Mux #4 Output Bitrate 24.900 Mbit/s
Per Mux Total Output Bitrate 38.815 Mbit/s
```

Data currently in use by the MUX

Unprocessed data

Data currently output by the MUX

Total amount of data (including null packets) output per RF channel

Example: Raw Bitrates Display

```
Slot #1 Raw bitrate data 14.228 Mbit/s total 19.396 Mbit/s
Slot #2 Raw bitrate data 12.537 Mbit/s total 19.390 Mbit/s
Slot #3 Raw bitrate data 0 total 0
Slot #4 Raw bitrate data 17.049 Mbit/s total 19.390 Mbit/s
Slot #5 Raw bitrate data 15.503 Mbit/s total 19.396 Mbit/s
Slot #6 Raw bitrate data 0 total 0
Slot #7 Raw bitrate data 0 total 0
Slot #8 Raw bitrate data 13.536 Mbit/s total 19.390 Mbit/s
Slot #9 Raw bitrate data 13.957 Mbit/s total 19.396 Mbit/s
Slot #10 Raw bitrate data 0 total 0
Slot #11 Raw bitrate data 7.520 Mbit/s total 19.396 Mbit/s
Slot #12 Raw bitrate data 18.620 Mbit/s total 19.396 Mbit/s
```

Total number of data bits that are not null packets

Total number of data bits in the transport stream

Configure Card Number/Channel Assignments

This option enables you to reconfigure the card number/channel assignments.

1. Access the HCS6300 Main Menu as described on page 31.
2. At the [Main] Command > prompt, type **crosspt** and press **Enter**.

The system displays the current channel assignments and prompts for the desired action, for example:

(Continued on next page)

Configuration Options via Command Line (Cont.)

(Continued from previous page)

1. RF 58-1 <-- Slot #1
2. RF 58-2 <-- Slot #2
3. RF 59-1 <-- Slot #4
4. RF 59-2 <-- Slot #5
5. RF 60-1 <-- Slot #8
6. RF 60-2 <-- Slot #9
7. RF 61-1 <-- Slot #11
8. RF 61-2 <-- Slot #12

Do you wish to change the mapping of physical slots to RF channels (y/n)?

3. To change the RF channel mapping, type **y** and press **Enter**.

Note: Type **n** and press **Enter** to return to the Main Menu prompt without changing the channel mapping.

4. At the Enter the mux input number [1 - 8] > prompt, type the line number for the channel you wish to reassign. Then, press **Enter**.

5. At the Enter the slot number [1 - 12] > prompt, type the slot number of the transcoder card you wish to assign to the selected channel. Then, press **Enter**.

The system confirms the new assignment:

Set Cross point switch... OK!

and then redisplay the channel assignments along with the Main Menu prompt.

6. Repeat steps 2 to 5 to remap additional channels.

Reset Password for Reload PI Key GUI Option

Users who wish to reload a selected transcoder's Pro:Idiom key from the GUI require a password in order to do so. This option enables you to reset the Pro:Idiom password to its default value ("service").

Note: Users also have the ability to set a new password during the process of reloading the Pro:Idiom key from the GUI (see "Change the [Reload Pro:Idiom Key] Password" on page 23).

1. Access the HCS6300 Main Menu as described on page 31.
2. At the [Main] Command > prompt, type **rstpwd** and press **Enter**.
3. At the Reset password (y/n)? prompt for confirmation, either:
 - Type **y** and press **Enter** to reset the default password immediately. The system confirms success (Password reset ok) and then redisplay the Main Menu prompt.
 - Type **n** and press **Enter** to abort the password reset. The system displays confirmation (Password reset. Aborted!) and then redisplay the Main Menu prompt.

Configuration Options via Command Line (Cont.)

Transcoder Menu Commands

The following subsections describe how to access and use the Transcoder Menu commands.

Note: Refer to the Installation & Setup Guide for the applicable transcoder cards for further information on transcoder configuration options.

Access the Transcoder Menu

1. Access the HCS6300 Main Menu as described on page 31.
2. At the [Main] Command > prompt, type **card** and press **Enter**.
3. At the Enter card number (1-12) > prompt, type the chassis slot number of the transcoder card for which you wish to access configuration options. Then, press **Enter**.

The system identifies the card type and then displays a command prompt for the card menu, for example:

```
Card #1 is: HCS7710
[HCS7710 (1)] Command >
```

4. At the Command > prompt, either:
 - Press **Enter** to display the card menu (see example below).
 - Type the desired command and press **Enter**.

Note: You can always press **Enter** at the Command > prompt to display the Transcoder Menu.

Example: Transcoder Menu

```
-----
HCS7710 Menu
-----
hwid      Read Hardware ID
ver       Read Software Versions
caget     Read Content Advisory Messages Setting *
caset     Enable/Disable Content Advisory Messages *
bits      Read MUX Bitrates
pi        Install PI Key
pr        Reload PI Key
cksum     Read PI Key Checksum
stb       Satellite Receiver Menu
upd       Update Firmware
irst      Internal Reset
ret       Return to Main Menu
[HCS7710 (1)] Command >
```

* These commands are applicable to HCS7700 and HCS7710 cards only. Refer to the LG Service Bulletin on Content Advisory configuration options for further information.

Configuration Options via Command Line (Cont.)

View Hardware Information for the Selected Transcoder

At the [Card (#)] Command > prompt, type **hwid** and press **Enter** to view the selected card's hardware ID (firmware version), for example:

```
Card HWID# is: 7710-v1.0-2010-1105
```

View Software Information for the Selected Transcoder

At the [Card (#)] Command > prompt, type **ver** and press **Enter** to view the selected card's software versions, for example:

```
OS version:           HCS7710-905-2010-0910
Encoder version:      1.1
Ethernet version:     1.0
Application version:  2.5
```

View MUX Bitrate Data for the Selected Transcoder

At the [Card (#)] Command > prompt, type **bits** and press **Enter**.

MUX bitrate data for the selected transcoder card is displayed in millions of bits per second (Mbit/s), for example:

```
HDMI Input Bitrate: 14.120 Mbit/s (raw 14.120 Mbit/s)
Ethernet Input Bitrate: 0 (raw 9.210 Mbit/s)
Data Output Bitrate: 16.881 Mbit/s
Total Output Bitrate: 19.396 Mbit/s
```

The example above shows MUX bitrate data for an HCS7710 card. Refer to the Installation & Setup Guide for the applicable transcoder card for further information on bitrate data.

Install a Pro:Idiom Key on the Selected Transcoder

This command installs the Pro:Idiom encryption key on the selected transcoder card. To install a Pro:Idiom key on all the transcoders, see "Install a Pro:Idiom Key on All Transcoders" on page 34.



Caution: Do NOT initiate simultaneous menu sessions while a Pro:Idiom key installation is in progress. Doing so will interfere with the active processes and may corrupt the system configuration and/or cause the HCS6300 card to cease normal operation.



Note: In order for a Pro:Idiom encrypted channel to be displayed, the receiver must contain a Pro:Idiom decrypter, and the receiver must be configured to allow decryption of the desired channel.

(Continued on next page)

Configuration Options via Command Line (Cont.)

(Continued from previous page)

 **Note:** The process of updating the encryption key will synchronize the decryption key in any receiver tuned to the cards' output. If the target receiver is turned off or viewing content from a different card, the synchronization will not occur, and the output will be scrambled. Ensure that all encrypters and decrypters in a system are synchronized to the same key.

1. Confirm the directory location of the Pro:Idiom key (.hex) file. Note: For a TFTP file transfer, the key file must be available on the same machine as the TFTP server.
2. At the `[Card (#)] Command >` prompt, type **pi** and press **Enter**.
3. At the `Use TFTP to transfer files (y/n)?` prompt, either:
 - Type **y** and press **Enter** to use TFTP for the firmware update.
 - Type **n** and press **Enter** if you will not use TFTP for the firmware update. At the next system prompt: `Use XMODEM to transfer files (y/n)?`, type **y** and press **Enter**.
4. Complete the update using the selected transfer mode (Xmodem or TFTP). Refer to "Install a Pro:Idiom Key on All Transcoders" on page 34 for further information.

The system will display progress messages as well as the result of the installation process. Note that the new key will be stored in non-volatile storage regardless of process results.

Reload the Pro:Idiom Key on the Selected Transcoder

This command reloads the Pro:Idiom encryption key on the selected transcoder card. To reload the Pro:Idiom key on all the transcoders, see "Reload the Pro:Idiom Key on All Transcoders" on page 36.

1. At the `[Card (#)] Command >` prompt, type **pr** and press **Enter**.
2. At the `Reload PI key. Continue (y/n)?` prompt, type **y** and press **Enter** to continue.

When the reload is complete, the system will display confirmation:

```
Reload PI complete OK
```

View the Pro:Idiom Key Checksum for the Selected Transcoder

At the `[Card (#)] Command >` prompt, type **cksum** and press **Enter** to display the Pro:Idiom key checksum for the selected transcoder, for example:

```
PI key checksum is xxxxxxxxxxxx
```

where `xxxxxxxxxx` is a 10-digit number that identifies the Pro:Idiom key file installed on the transcoder.

 **Note:** All transcoder cards in the card frame must have the same Pro:Idiom key file installed.

Configuration Options via Command Line (Cont.)

Access the Satellite Receiver Menu for the Selected Transcoder

See “Satellite Receiver Menu Commands” on pages 44 to 47 for detailed information on satellite STB configuration options.

Update Firmware on the Selected Transcoder

This command updates the firmware on the selected transcoder card. To update firmware on all transcoders or on the HCS6300, see “Update HCS6300 and/or Transcoder Firmware” on page 36.

 **Caution: Do NOT initiate simultaneous menu sessions while a firmware update is in progress. Doing so will interfere with the active processes and may corrupt the system configuration and/or cause the HCS6300 card to cease normal operation.**

If you are not sure of the current firmware version, view and record the transcoder hardware ID (firmware version) before you initiate the firmware update. See “View Hardware Information for the Selected Transcoder” on page 41.

1. Confirm the directory location of the required firmware update configuration (.cfg) and package (.pkg) files. Note: For a TFTP file transfer, the firmware update files must be available on the same machine as the TFTP server.
2. At the `[Card (#)] Command >` prompt, type **upd** and press **Enter**.
3. At the `Use TFTP to transfer files (y/n)?` prompt, either:
 - Type **y** and press **Enter** to use TFTP for the firmware update.
 - Type **n** and press **Enter** if you will not use TFTP for the firmware update. At the next system prompt: `Use XMODEM to transfer files (y/n)?`, type **y** and press **Enter**.
4. Complete the update using the selected transfer mode (Xmodem or TFTP). Refer to “Update HCS6300 and/or Transcoder Firmware” on page 36 for further information.
5. Reset the transcoder card (see “Reset the Selected Transcoder Card” below).

Reset the Selected Transcoder Card

At the `[Card (#)] Command >` prompt, type **irst** and press **Enter** to initiate the reset. After reset, the transcoder card resumes normal operation.

Return to the HCS6300 Main Menu

At the `[Card (#)] Command >` prompt, type **ret** and press **Enter** to return to the HCS6300 Main Menu.

Configuration Options via Command Line (Cont.)

Satellite Receiver Menu Commands

The following subsections describe how to access and use the Satellite Receiver Menu commands.

Access the Satellite Receiver Menu

1. Access the card menu for the selected transcoder (see “Access the Transcoder Menu” on page 40).
2. At the `[Card (#)] Command >` prompt, type **stb** and press **Enter**.
3. At the `[Satellite (#)] Command >` prompt, either:
 - Press **Enter** to display the Satellite Receiver Menu (see example below).
 - Type the desired command and press **Enter**.

Note: You can always press **Enter** at the `Command >` prompt to display the Satellite Receiver Menu.

Example: Satellite Receiver Menu

```
-----  
Satellite Receiver Menu  
-----
```

```
getch      Read Current STB Channel  
setch      Set STB Channel  
lksts      Read Satellite Lock Status  
sglvl      Read Satellite Signal Strength  
actsts     Read STB Activation Status  
cnum       Read Access Card Number  
bnum       Read STB Serial Number  
osdon      Set Satellite OSD On  
osdoff     Set Satellite OSD Off  
on         Turn STB On  
off        Turn STB Off (Standby)  
stbrst     Reset Satellite STB  
atune      Read Auto Tune Parameters  
atset      Set Auto Tune Parameters  
ret        Return to Card Menu
```

where:

is the chassis card/slot number you selected for configuration purposes.

```
[Satellite (#)] Command >
```

Configuration Options via Command Line (Cont.)

Read the Current STB Channel

At the [Satellite (#)] Command > prompt, type **getch** and press **Enter** to display the currently selected satellite STB channel number, for example:

```
Card 1: Current STB Channel is 209
```

If you receive an error message, it may be necessary to reset the satellite STB either using the “Reset Satellite STB” command described on page 46 or using the RESET button on the STB front panel.

Set the STB Channel

1. At the [Satellite (#)] Command > prompt, type **setch** and press **Enter** to retune the satellite STB.
2. At the Please enter the channel number > prompt, type the desired three-digit channel number and press **Enter**.

If the channel is set successfully, the satellite STB will change to the specified DIRECTV channel, and the system will display confirmation, for example:

```
Card 1: Channel changed to 210
```

Read the Satellite Lock Status

At the [Satellite (#)] Command > prompt, type **lksts** and press **Enter** to determine whether or not the satellite STB is locked to the satellite, for example:

```
Card 1: Satellite signal is locked
```

Read the Satellite Signal Strength

At the [Satellite (#)] Command > prompt, type **sglvl** and press **Enter** to display the satellite signal strength (displayed as a percentage) at the Satellite In jack on the satellite STB, for example:

```
Card 1: Satellite signal strength is 52%
```

Read the Satellite STB Activation Status

At the [Satellite (#)] Command > prompt, type **actsts** and press **Enter** to display the activation status—yes or no—of the satellite STB.

Read the Satellite STB Access Card Number

At the [Satellite (#)] Command > prompt, type **cnum** and press **Enter** to display the satellite STB access card serial number, for example:

```
Card 1: Access card serial number is 002468525676
```

Configuration Options via Command Line (Cont.)

Read the Satellite STB Serial Number

At the [Satellite (#)] Command > prompt, type **bnum** and press **Enter** to display the satellite STB serial number, for example:

```
Card 1: STB serial number is 029265702091
```

Set Satellite OSD On or Off

At the [Satellite (#)] Command > prompt, either:

- Type **osdon** and press **Enter** to enable on-screen display for the video signal at the HDMI output.
- Type **osdoff** and press **Enter** to disable on-screen display for the video signal at the HDMI output. Note that the Ethernet video stream does not contain on-screen display.

Power the Satellite STB On or Off

“Turn STB On” and “Turn STB Off” options in the Satellite Receiver Menu enable you to power ON a satellite STB from standby mode or power OFF a satellite STB to standby mode.

At the [Satellite (#)] Command > prompt, either:

- Type **on** and press **Enter** to power ON the satellite STB.
- Type **off** and press **Enter** to switch the satellite STB to standby mode. HDMI output is disabled, but the Ethernet port continues to stream audio and video.

Reset the Satellite STB

At the [Satellite (#)] Command > prompt, type **stbrst** and press **Enter** to reset the satellite STB. After reset, the satellite STB resumes normal operation.

Auto Tune Parameters

The Auto Tune feature, enabled by default to run every day at 3 AM (for approximately 20 seconds), allows the COM 23 satellite STB to re-synchronize its audio and video buffers. The default primary and secondary channels specified for auto tuning purposes are 202 (CNN) and 206 (ESPN), respectively.

You can view the current status of auto tuning, and/or you can modify or disable the auto tune settings, if required.

Read Auto Tune Parameters

At the [Satellite (#)] Command > prompt, type **atune** and press **Enter** to view auto tune parameters, for example:

```
Auto tune is Enabled
Auto tune time (0-23): 3
Primary tune to channel: 202
Secondary tune to channel: 206
```

Configuration Options via Command Line (Cont.)

Set/Modify Auto Tune Parameters

1. At the `[Satellite (#)] Command >` prompt, type **atset** and press **Enter**.
2. At the `Change auto tune settings (y/n)?` prompt, either:
 - Type **y** and press **Enter** to modify the current auto tune settings.
 - Type **n** and press **Enter** to return to the Satellite Receiver Menu without modifying the auto tune settings.
3. At the `Enable auto tune (y/n)?` prompt, either:
 - Type **y** and press **Enter** to enable and configure auto tune settings. Continue with step 4.
 - Type **n** and press **Enter** to disable auto tuning on the transcoder. Go to step 7.
4. At the `Enter auto tune time (0-23)` prompt, type the hour, in 24-hour clock format, at which the auto tune will run. Then, press **Enter**. Make sure to choose a time when TVs are not likely to be in use, as the picture will change for approximately 20 seconds during the auto tune.

Note: If you type an invalid entry at any of the auto tune settings prompts, the system will retain the existing settings and return immediately to the Satellite Receiver Menu. Repeat steps 3 to 6 to configure all of the settings.

5. At the `Enter the primary tune to channel` prompt, enter an HD MPEG-4 channel from the subscribed channel lineup as the primary auto tune channel. Then, press **Enter**.
6. At the `Enter the secondary tune to channel` prompt, enter an HD MPEG-4 channel from the subscribed channel lineup as the secondary auto tune channel. Then, press **Enter**. (If the transcoder is set to the primary auto tune channel, the secondary channel will be used for auto tuning.)

After you enter the secondary channel, the system will display confirmation: `Auto tune set... OK`

7. Without further user intervention:
 - Any modifications to auto tune time or channel settings or a change from “enabled” to “disabled” status will take effect after the current auto tune cycle is completed. For example, if auto tune was previously scheduled for 5 AM, and you just disabled auto tuning, the changes will not take effect until after the next 5 AM auto tune cycle completes.
 - If you enabled auto tuning after it had been previously disabled, the change will not take effect until 3 AM.

To implement changes immediately, return to the card menu (see section below), and reset the transcoder (see “Reset the Selected Transcoder Card” on page 43).

Return to the Transcoder Menu

At the `[Satellite (#)] Command >` prompt, type **ret** and press **Enter** to return to the card menu.

Troubleshooting

This section provides troubleshooting information for the HCS6300. You can find additional troubleshooting help at www.DIRECTV.com.

Equipment Setup Review

- Make sure all connectors and connections are tight and secure on all entertainment system components.
- Check the Ethernet connection; is it viable and working?
 - Observe the green and amber LEDs on the Ethernet connector.
 - The green LED should blink rapidly.
 - The amber LED should stay lit constantly.
- Ensure the COM 23 access card is installed, up-to-date, and authorized by DIRECTV.

STATUS LED

The green STATUS LED on the HCS6300 front panel provides general information about the operating condition of the card. Observe the STATUS LED, and refer to the following table:

STATUS LED Behavior	Operating Status
Slow Blinking	Power Up State
Rapid Blinking	Error Condition
Continuously On	Normal Operation
Continuously Off	Fault Condition, No Output

Audio/Video Freeze or Blank Screen

Perform one or more of the following (in order):

- Remove and reinsert the COM 23 access card.
- Press the RESET button located on the front of the COM 23, and allow the STB to retrieve the DIRECTV program guide.
- Unplug the power cord of the COM 23 for 15 seconds; then plug it in again.
- Use a small object (for example, a paperclip) to press the recessed RESET button on the HCS6300. Hold for five seconds to initiate the reset.
- Unplug the power cord of the CodePlus card frame for 15 seconds; then plug it in again.

Specifications

Dimensions

Height: 3U (130.20 mm)
Width: 1.102362 inches (28.00 mm)
Depth: 9.055118 inches (230.00 mm)
Weight: 0.5 pounds (0.221 kgrms) Est.

Environmental Storage Conditions

Temperature: -20° to 70° Celsius
-4° to 158° Fahrenheit
Humidity: 95% non-condensing

Operating Conditions

Temperature: 0° to 40° Celsius
32° to 104° Fahrenheit
Humidity: 95% non-condensing

Electrical

RF Out Connector:	Type 'F'
RF Output Span:	4 Contiguous Channels (typically 24 MHz)
RF Output Frequency Range:	54 MHz to 864 MHz
DC Input:	+12V DC @ 1.35 Amps
Active Output Level at RF Out jack:	+ 42 dBmV Min.
Ethernet Input:	10/100BaseT

Note: Design and specifications subject to change without prior notice.

Document Revision History / Notes

Document Revision History

Date	Description
July 2010	Revision A: New document
August 2012	Revision B: Updates for GUI and additional HCS6300 configuration options

Product documentation is available online at: www.LGolutions.com/products. From the Products page, select **TVs, Systems & Solutions**, then **Head End Systems**, then **CodePlus Transcoder Series** (click **Show [+]** to view the list of products), then the applicable Modular System option. Click the **Literature & Downloads** tab at the bottom of the Modular System page, and select the required document(s) from the Downloads list.

Notes

Open Source Software Notice

The following GPL executables used in this product are subject to the GPL Version 2.0 License Agreements.

GPL EXECUTABLES: Linux kernel 2.6.26, boa 0.94, busybox 1.10.1, dhcpcd 0.70, eraseall 1.7, inetd 1.0, lrzsz 0.12.20, simpleinit 1.21

LG Electronics offers to provide source code to you on CD-ROM for a charge covering the cost of performing such distribution, such as the cost of media, shipping and handling upon e-mail request to LG Electronics at: opensource@lge.com. This offer is valid for a period of three (3) years from the date of the distribution of this product by LG Electronics.

You can obtain a copy of the GPL license from: <http://www.gnu.org/licenses/old-licenses/gpl-2.0.html>.

This product includes:

- echo:
Copyright © 1998 David I. Bell
Permission is granted to use, distribute, or modify this source, provided that this copyright notice remains intact.
- telnet v1.9:
Copyright © 1989 The Regents of the University of California
 1. Redistributions of source code must retain the above copyright notice, this list of conditions and the following disclaimer.
 2. Redistributions in binary form must reproduce the above copyright notice, this list of conditions and the following disclaimer in the documentation and/or other materials provided with the distribution.
 3. All advertising materials mentioning features or use of this software must display the following acknowledgement: This product includes software developed by the University of California, Berkeley and its contributors.
 4. Neither the name of the University nor the names of its contributors may be used to endorse or promote products derived from this software without specific prior written permission.

All rights reserved.

Permission is hereby granted, free of charge, to any person obtaining a copy of this open source software and associated documentation files (the "Software"), to deal in the Software without restriction, including without limitation the rights to use, copy, modify, merge, publish, distribute, sublicense, and/or sell copies of the Software, and to permit persons to whom the Software is furnished to do so, subject to the following conditions:

SUBJECT TO THE TERMS OF THE GPL VERSION 2.0 LICENSE AGREEMENTS, THE SOFTWARE IS PROVIDED "AS IS", WITHOUT WARRANTY OF ANY KIND, EXPRESS OR IMPLIED, INCLUDING BUT NOT LIMITED TO THE WARRANTIES OF MERCHANTABILITY, FITNESS FOR A PARTICULAR PURPOSE AND NONINFRINGEMENT. IN NO EVENT SHALL THE AUTHORS, COPYRIGHT HOLDERS, OR LG ELECTRONICS (THE "LICENSOR") BE LIABLE FOR ANY CLAIM, DAMAGES OR OTHER LIABILITY, WHETHER IN AN ACTION OF CONTRACT, TORT OR OTHERWISE, ARISING FROM, OUT OF OR IN CONNECTION WITH THE SOFTWARE OR THE USE OR OTHER DEALINGS IN THE SOFTWARE, EVEN IF LICENSOR HAS BEEN ADVISED OF THE POSSIBILITY OF SUCH DAMAGES. LICENSEE ASSUMES THE COST OF ALL NECESSARY SERVICING, REPAIR, OR CORRECTION.

LG HCS6300 MUX/MOD Feature Card Warranty

Broadcast Products Welcome to the LG family! We believe that you will be pleased with your new HCS6300 MUX/MOD feature card. Please read this warranty carefully, it is a "LIMITED WARRANTY" as defined under Federal Law. This warranty gives you specific legal rights, and you may also have other rights that vary from state-to-state within the U.S.A.

LG's RESPONSIBILITY

Warranty Term One year parts and labor from date of purchase or delivery date.

Parts New or remanufactured replacements for factory-defective parts may be used. Such replacement parts are warranted for the remaining portion of the original warranty period.

Warranty Service Warranty service is provided at LG. Customer pays for shipping charges to LG; LG pays for return shipping charges to return HCS6300 to customer. Call **1-888-865-3026** for further information.

Not Covered This warranty covers manufacturing defects and does not cover installation, adjustment of customer controls, installation or repair of antenna systems, cable converters or cable company-supplied equipment; it also does not cover damage due to misuse, abuse, negligence, acts of God or other causes beyond the control of LG. Any alteration of the product after manufacture voids this warranty in its entirety.

This warranty does not cover any missing or stolen access cards.

THIS WARRANTY IS IN LIEU OF ANY OTHER WARRANTY, EXPRESS OR IMPLIED, INCLUDING WITHOUT LIMITATION, ANY WARRANTY OF MERCHANTABILITY OR FITNESS FOR A PARTICULAR PURPOSE, AND LG SHALL NOT BE LIABLE FOR ANY CONSEQUENTIAL, INDIRECT, OR INCIDENTAL DAMAGES OF ANY KIND, INCLUDING LOST REVENUES OR PROFITS IN CONNECTION WITH THIS PRODUCT. SOME STATES DO NOT ALLOW LIMITATIONS ON HOW LONG AN IMPLIED WARRANTY LASTS OR THE EXCLUSION OR LIMITATION OF INCIDENTAL OR CONSEQUENTIAL DAMAGES, SO THE ABOVE LIMITATIONS OR EXCLUSIONS MAY NOT APPLY TO YOU.

OWNER'S RESPONSIBILITY

Effective Warranty Date Warranty begins on the date of delivery of the HCS6300.
For your convenience, keep the dealer's dated bill of sale or delivery ticket as evidence of the purchase date.

Installation Guide Read the Installation & Setup Guide carefully so that you will understand the operation of the HCS6300 and how to adjust the controls.

Antenna Reception problems caused by inadequate antenna or faulty antenna connections are the owner's responsibility.

Warranty Service **For warranty service information, Call 1-888-865-3026.** Parts and service labor that are LG's responsibility (see above) will be provided without charge. Other service is at the owner's expense. If you have any problem in obtaining satisfactory warranty service, call **1-888-865-3026**.
You must provide the model number, serial number and date of purchase or date of original installation.

For Customer Support/Service, please call:

1-888-865-3026

www.LGolutions.com

CodePlus is a trademark of LG Electronics U.S.A., Inc. Pro:Idiom is a registered trademark of Zenith Electronics LLC. DIRECTV is a registered trademark of DIRECTV, Inc. All other trademarks or registered trademarks are the property of their respective owners.

Free Manuals Download Website

<http://myh66.com>

<http://usermanuals.us>

<http://www.somanuals.com>

<http://www.4manuals.cc>

<http://www.manual-lib.com>

<http://www.404manual.com>

<http://www.luxmanual.com>

<http://aubethermostatmanual.com>

Golf course search by state

<http://golfingnear.com>

Email search by domain

<http://emailbydomain.com>

Auto manuals search

<http://auto.somanuals.com>

TV manuals search

<http://tv.somanuals.com>