

website : <http://www.LGService.com>
e-mail : <http://LGService.com/techsup.html>

WASHING MACHINE SERVICE MANUAL

CAUTION

READ THIS MANUAL CAREFULLY TO DIAGNOSE TROUBLE
CORRECTLY BEFORE OFFERING SERVICE.

**MODEL : WD(M)-65130F
WD(M)-80130F
WD(M)-10130(5)F
WD(M)-10131F**

CONTENTS

1. SPECIFICATION.....	3
2. FEATURES & TECHNICAL EXPLANATION	4
3. PARTS IDENTIFICATION	6
4. INSTALLATION.....	7
5. OPERATION.....	10
6. WIRING DIAGRAM/PROGRAM CHART	14
7. TROUBLESHOOTING.....	15
7-1.BEFORE PERFORMING SERVICE	15
7-2.TEST MODE	15
7-3.ERROR DISPLAY	16
8. ERROR DIAGNOSIS AND CHECK LIST	17
8-1. DIAGNOSIS AND ANSWER FOR ABNORMAL OPERATION	17
8-2. FAULT DIAGNOSIS AND TROUBLESHOOTING	20
9. DISASSEMBLY INSTRUCTIONS	26
10. EXPLODED VIEW	33
10-1. THE EXPLODED VIEW OF CABINET ASSEMBLY	33
10-2. THE EXPLODED VIEW OF CONTROL PANEL & DISPENSER ASSEMBLY.....	34
10-3. THE EXPLODED VIEW OF DRUM & TUB ASSEMBLY.....	35
*APPENDIX (Replacement parts list).....	36

1. SPECIFICATION

ITEM		WD(M)-65130F, WD(M)-80130F, WD(M)-10130(1, 5)F		
POWER SUPPLY		220-240V~, 50Hz		
PRODUCT WEIGHT		67kg		
ELECTRICITY CONSUMPTION	WASHING	190W		
	SPIN (800rpm)	450W		
	DRAIN MOTOR	32W		
REVOLUTION SPEED	WASH HEATER	2000W		
	WASH	45rpm		
	SPIN	WD(M)-65130F	400/500/650 rpm	
		WD(M)-80130F	400/600/800 rpm	
WD(M)-10130(1, 5)F		400/800/1000 rpm		
OPERATION WATER PRESSURE		0.3-10kgf/cm ² (30-1000kPa)		
CONTROL TYPE		Electronic		
WASH CAPACITY		7.0kg		
		Synthetic (3.5kg), Delicate (3.0kg) Wool (2.0kg), Hand Wash(2.0kg), Quick 30(2.0kg)		
DIMENSION		600mm(W) × 600mm(D) × 850mm(H)		
WASH PROGRAM		Cotton, Synthetic, Delicate, Wool, Hand Wash, Quick 30, Rinse+Spin, Pump		
OPTION		Pre Wash, Time Save, Rinse+, Crease Care		
DOOR SWITCH TYPE		Bi-Metal type		
WATER LEVEL		9 steps (by sensor)		
SENSING OF THE LAUNDRY AMOUNT		Adopted		
FUZZY LOGIC		Adopted		
ERROR DIAGNOSIS		7 items		
POWER AUTO OFF		Adopted		
CHILD LOCK		Adopted		

2. FEATURES & TECHNICAL EXPLANATION

2-1.FEATURES



■ **Jumbo drum**

LG's jumbo drum can wash about 40% more per load than conventional washing machine. A bigger drum improves the wash performance.



■ **Protection against wrinkles**

With the alternate rotation of the drum, wrinkling in the laundry is minimized.



■ **More economical by Fuzzy Logic System**

FUZZY Logic System detects the amount of load and water temperature, and then determines the optimum water level and washing time to minimize energy and water consumption.

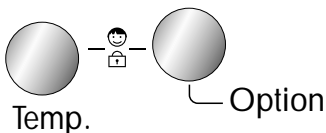

■ **Child-Lock**

The Child-Lock system has been developed to prevent children from pressing any button (except Power button) to change the program during operation.

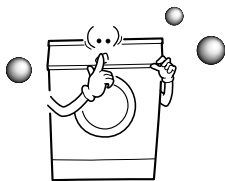

■ **Low noise speed control system**

By sensing the amount of load and balance, automatical distributes load evenly to minimize the spinning noise level.

2-2.DETERMINE WASHING TIME BY FUZZY LOGIC

To get the best washing performance optimal time is determined by sensing of water temperature, selected washing temperature and laundry amount.

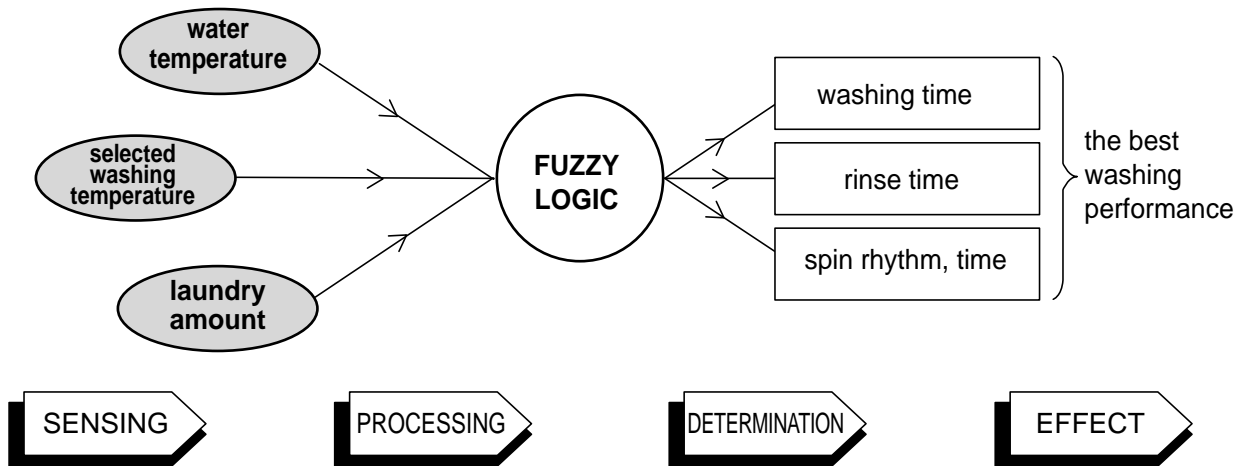

2-3.WATER LEVEL CONTROL

- This model adopts a pressure sensor which can sense the water level in the tub.
- When the water level reaches to the preset level the water supply is stopped, then the washing program proceeds.
- Spinning does not proceed until the water in the tub reduces a certain level.

2-4.THE DOOR CAN NOT BE OPENED

- While program is operating.

3. PARTS IDENTIFICATION

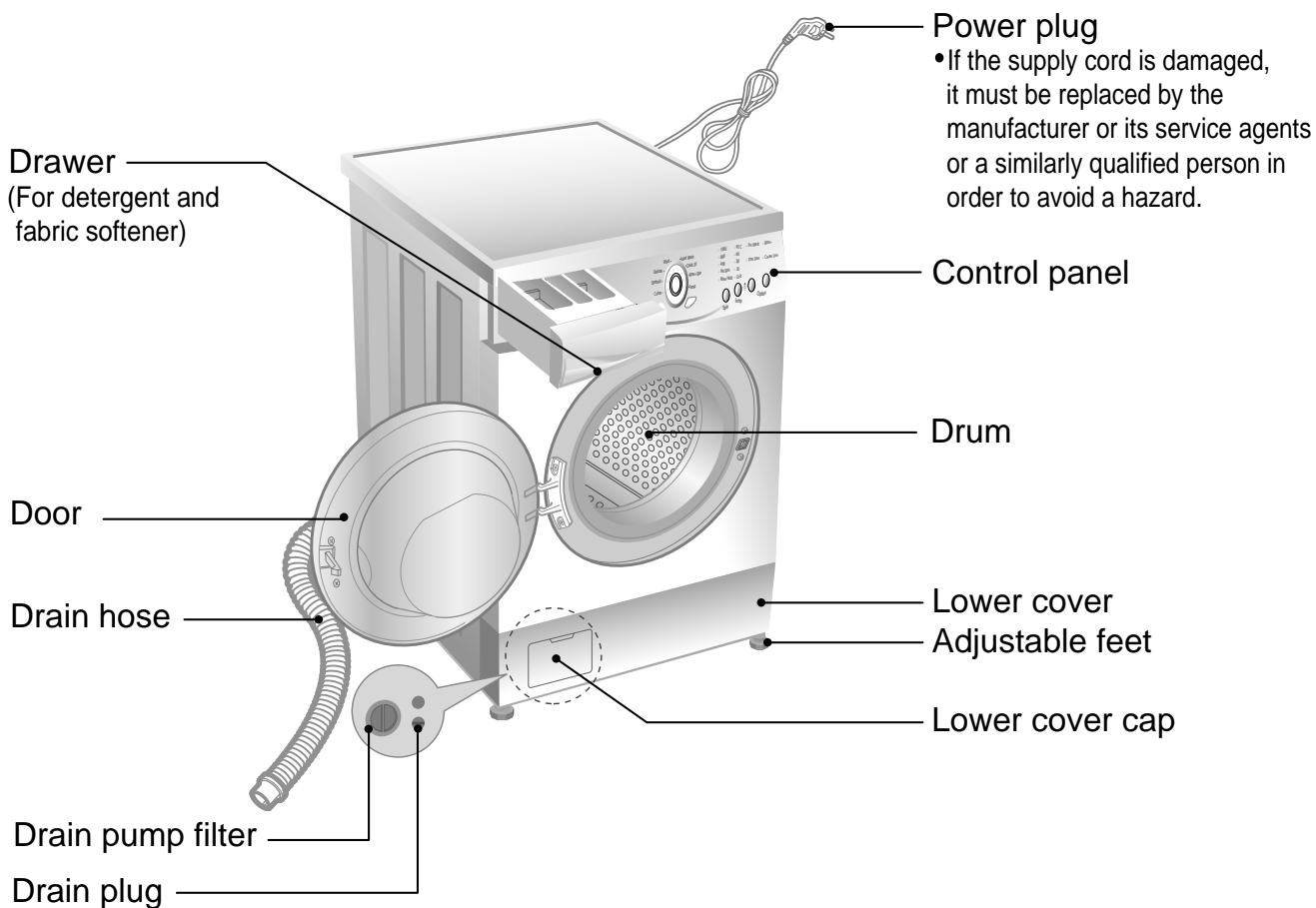

■ ACCESSORIES

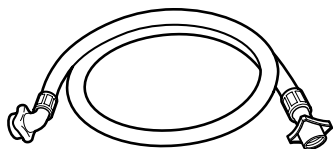

Cold (1EA)
※Option : Hot / Cold (2EA)

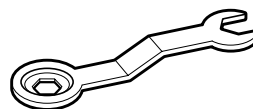

Wrench

4. INSTALLATION

- ① Before servicing ask the customer what the trouble is.
- ② Check the adjustment (power supply is 220-240V, remove the transit bolts....)
- ③ Check the troubles referring to the troubleshooting.
- ④ Decide service steps referring to disassembly instructions.
- ⑤ Then, service and repair.
- ⑥ After servicing, operate the appliance to see whether it works O·K or NOT.

■ STANDARD INSTALLATION

The appliance should be installed as follows.

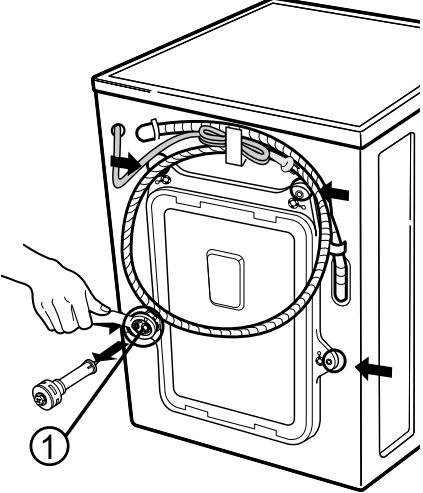
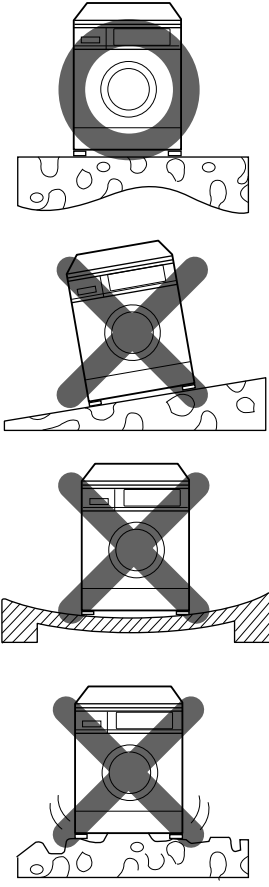
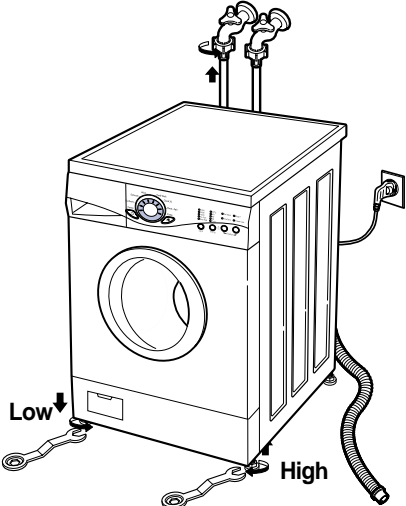
REMOVE THE TRANSIT BOLTS	INSTALL THE APPLIANCE ON FLAT AND FIRM SURFACE	ADJUST THE HORIZONTAL
<ul style="list-style-type: none"> • Remove the transit bolts (4EA: ①) with supplied wrench. • Keep the transit bolts and wrench for future use. • Insert the 4 caps provided into the hole. 		<ul style="list-style-type: none"> • Turn the adjustable feet to set the appliance horizontally.  <ul style="list-style-type: none"> • The appliance goes up by rotating the feet clockwise. • The appliance comes down by rotating the feet counter-clockwise.

■ HOW TO CONNECT INLET HOSE

- Check that the rubber washer is inside of the valve connector.
- Connect the inlet hose firmly to prevent leak.

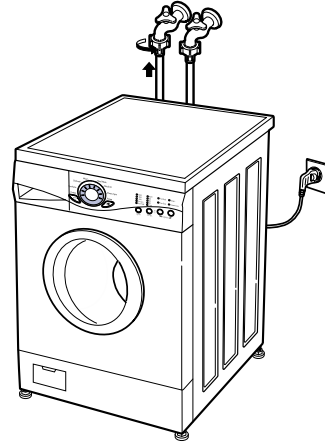

■ CONNECT DRAIN HOSE

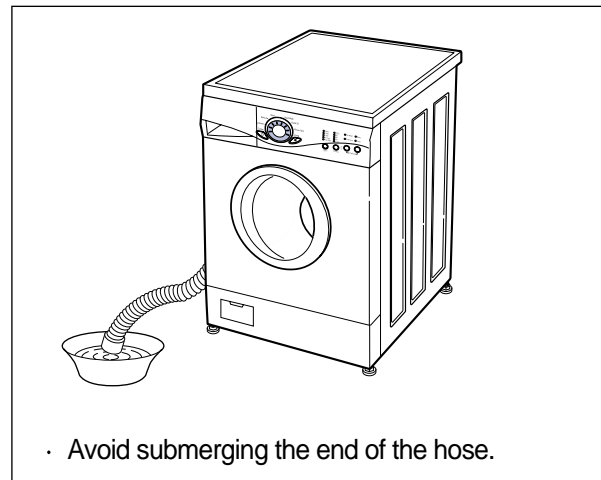
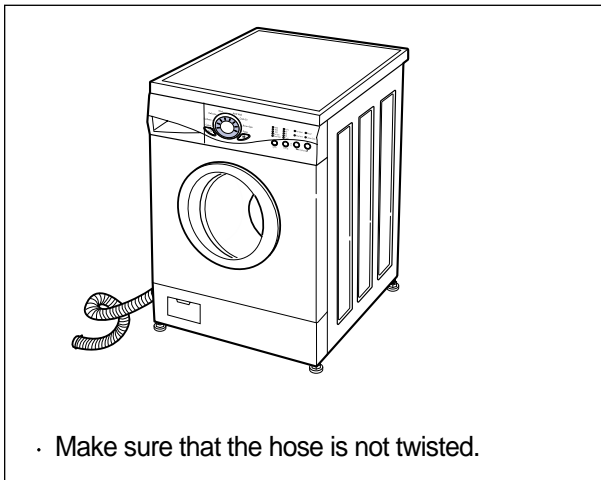

※ The drain hose should be placed under 100cm from the floor.

■ CONNECT POWER PLUG

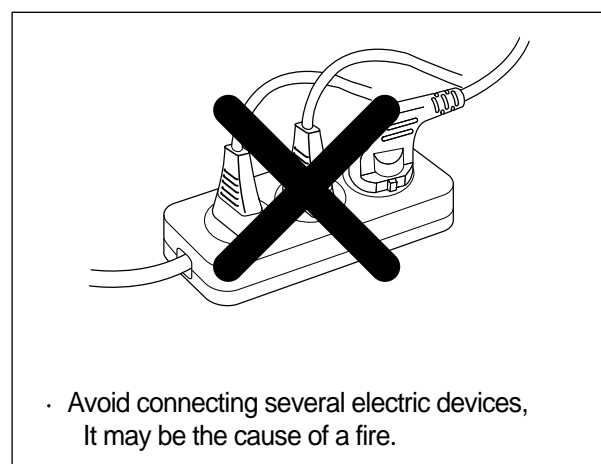
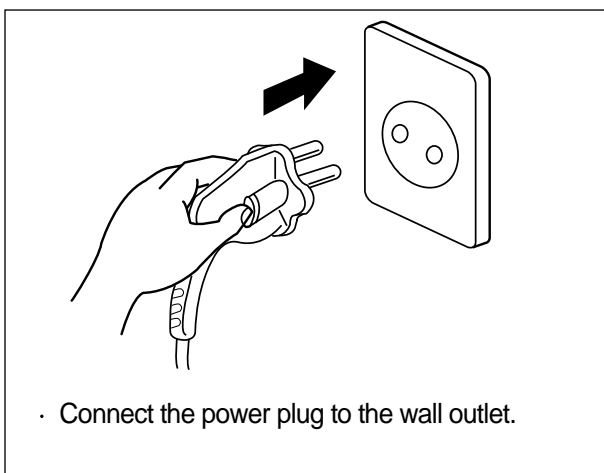

7 TEST OPERATION

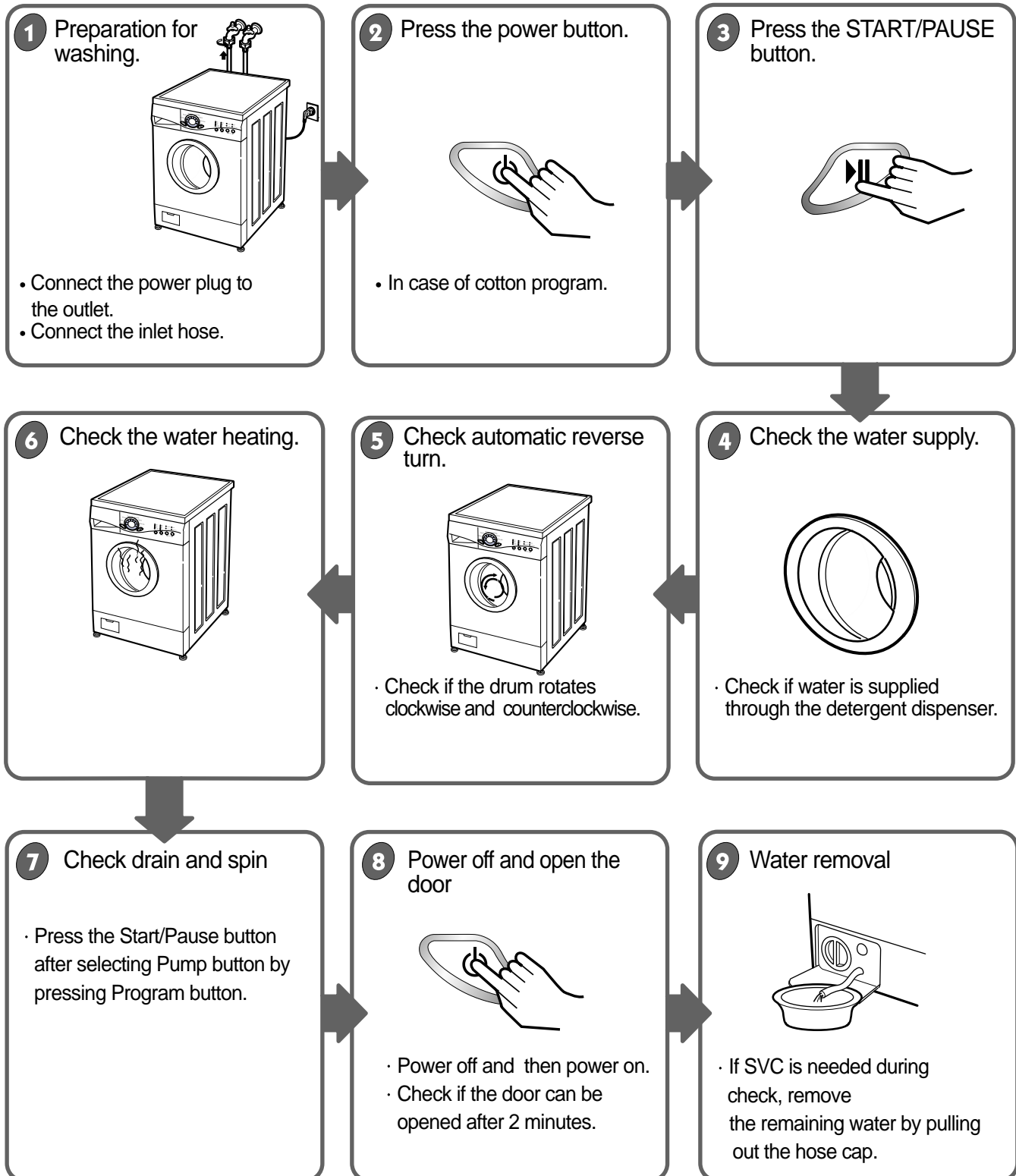

5. OPERATION

Wash program selector

- 8 programs can be set depending on the type of the laundry.
- By pressing the button [Cotton → Synthetic → Delicate → Wool → Hand Wash → Quick 30 → Rinse+Spin → Pump] can be selected.

Power button

- Press the button to turn on and off.

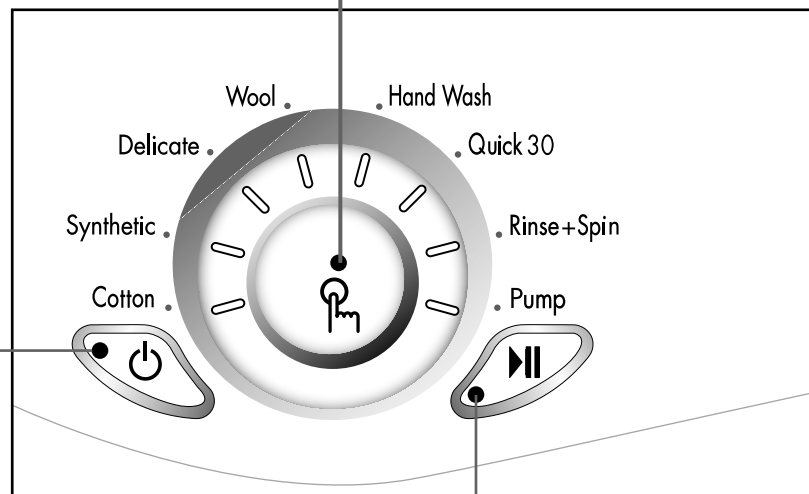

Start/Pause button

- Use the button to start or pause wash cycle.
- The power turn off automatically 4 minutes after the pause button is pressed.

Spin

- WD(M)-10130(1, 5)F
No Spin → Rinse Hold → 400 → 800 → 1000
- WD(M)-80130F
No Spin → Rinse Hold → 400 → 600 → 800
- WD(M)-65130F
No Spin → Rinse Hold → 400 → 500 → 650

Option

- Pre Wash :**
- If the laundry is heavily soiled, "Pre Wash" course is effective.
 - Pre Wash is available in Cotton and Synthetic Program.
- Time Save :**
- By selecting the Time Save option, the wash time may be reduced, depending on the program selected.

- 1000
- 800
- 400
- No Spin
- Rinse Hold
- 95 °C
- 60
- 40
- 30
- Cold
- Pre Wash
- Time Save
- Rinse+
- Crease Care

Spin

Temp.

Option

Option

- Rinse+ : If you wish to rinse more, the Rinse+ option will remove any trace of detergents.
- Crease Care : If you want to prevent crease, select this function after selecting spin speed.

Water temperature selector

- Press the button to select water temperature.
- The water temperature [40 °C → 60 °C → 95 °C → Cold → 30 °C] can be selected in Cotton.
- 95 °C is selected for Cotton only.

Child - lock

NOTE

- If the Program lamps are blinked at the same time after the power off or the end of the washing, the child lock mode is set. Cancel the child lock mode by pressing the [Temp.] and the [Option] button simultaneously for 3 seconds.
- Child Lock system can be set and canceled by pressing both [Temp.] and [Option] button simultaneously for 3 seconds.
 - Once Child Lock is set, all button are inoperable except power button.
 - Child Lock system can be set anytime even during Power-off and operation.
 - It is automatically cancelled when an operational error occurs.

Wash program selector

- 8 programs can be set depending on the type of the laundry.
- By pressing the button [Cotton → Synthetic → Delicate → Wool → Hand Wash → Quick 30 → Rinse+Spin → Pump] can be selected.

Power button

- Press the button to turn on and off.

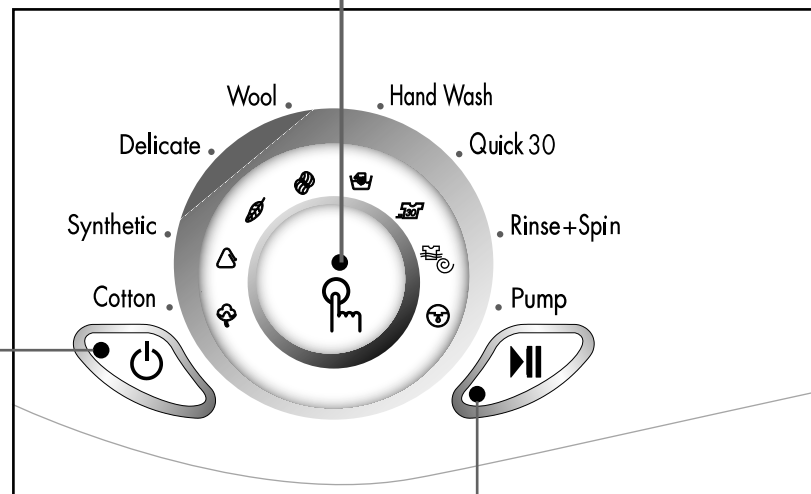

Start/Pause button

- Use the button to start or pause wash cycle.
- The power turn off automatically 4 minutes after the pause button is pressed.

Spin

- WD(M)-10130(1, 5)F
No Spin → Rinse Hold → 400 → 800 → 1000
- WD(M)-80130F
No Spin → Rinse Hold → 400 → 600 → 800
- WD(M)-65130F
No Spin → Rinse Hold → 400 → 500 → 650

Option

Pre Wash : • If the laundry is heavily soiled, "Pre Wash" course is effective.
• Pre Wash is available in Cotton and Synthetic Program.

Time Save : • By selecting the Time Save option, the wash time may be reduced, depending on the program selected.

- 1000
- 800
- 400
- No Spin
- Rinse Hold
- 95 °C
- 60
- 40
- 30
- Cold
- Pre Wash
- Time Save
- Rinse+
- Crease Care

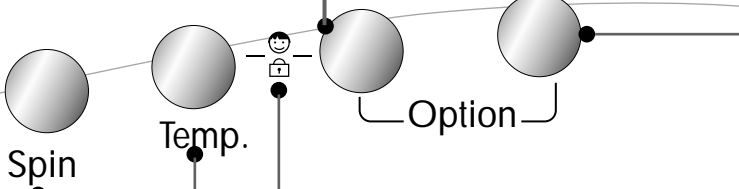

Option

• Rinse+ : If you wish to rinse more, the Rinse+ option will remove any trace of detergents.

• Crease Care : If you want to prevent crease, select this function after selecting spin speed.

Water temperature selector

- Press the button to select water temperature.
- The water temperature [40 °C → 60 °C → 95 °C → Cold → 30 °C] can be selected in Cotton.
- 95 °C is selected for Cotton only.

Child - lock

NOTE

If the Program lamps are blinked at the same time after the power off or the end of the washing, the child lock mode is set. Cancel the child lock mode by pressing the [Temp.] and the [Option] button simultaneously for 3 seconds.

- Child Lock system can be set and canceled by pressing both [Temp.] and [Option] button simultaneously for 3 seconds.
- Once Child Lock is set, all button are inoperable except power button.
- Child Lock system can be set anytime even during Power-off and operation.
- It is automatically cancelled when an operational error occurs.

6. WIRING DIAGRAM / PROGRAM CHART

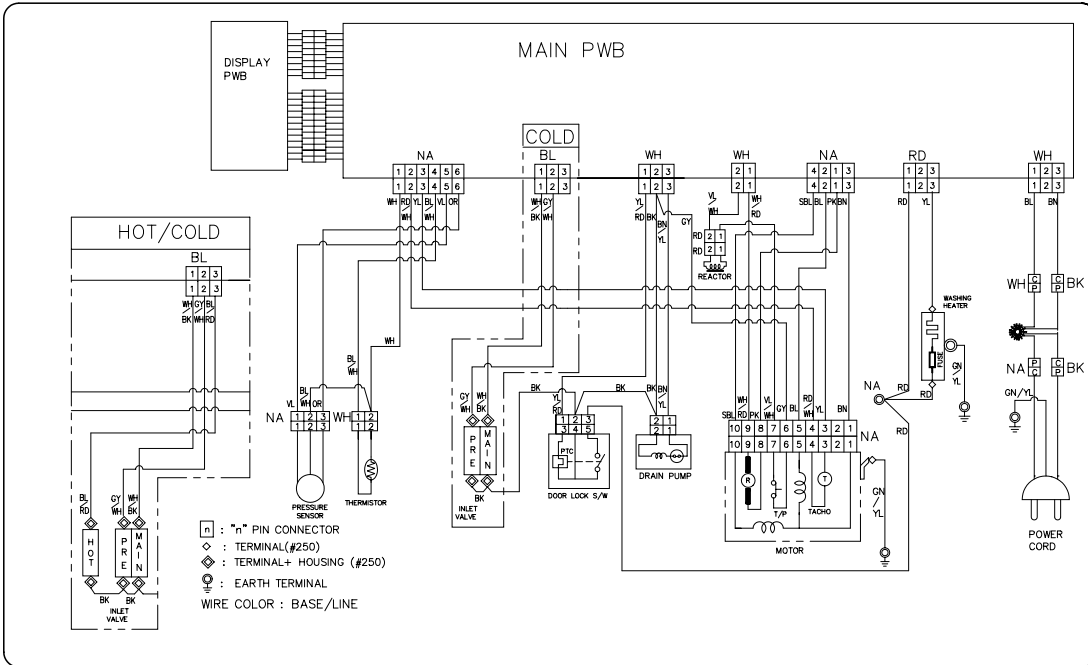

* Water Supply : WÆ * Intermittent Spin : IÆ * Disentangle : DÆ

C Y C L E S T E P	Washing										Rinse								Spin			A U T O F F	Normal Working Time (Hour:Minute)						
	Pre			Main		Normal					Rinse +			DÆ	Spin	DÆ													
	WÆ	S	Drain	IÆ	S	WÆ	S	Drain	Drain	1		2					3		4										
										WÆ	S	WÆ	S	WÆ	S	WÆ	S	WÆ	S	WÆ	S			WÆ	S				
Time (SEC)	120	MIN	60	240	120		MIN	120	60	60	60	240	120	360	60	240	120	360	60	240	120	360	60	480	120	20	20		
Cotton							58																						About 2:38
Synthetic							95																						About 1:23
Delicate							24																						About 58
Wool							18																						About 58
Handwash							18																						About 57
Quick 30							24																						About 30
Rinse + Spin																													About 19
Pump																													About 1

* Basic Cycle
 * Optional Cycle

* Pre-Setting Time : Water Supply - 120 sec.
 Drain - 60 sec.

* ~ Time for varies as the temperature or the amount of laundry

* Basic time is minute in washing chart

* The actual program time can be varied with the load amount, water temperature or ambient temperature

* **Pre Wash** : • If the laundry is heavily soiled, "Pre Wash" course is effective.
 • Pre Wash is available in Cotton and Synthetic.

* **Time Save** : • This option can be used to reduce the time of a wash program.
 • To use this option press the Time Save button once before the wash program is started.
 • This option is not available with Quick 30 program.

* **Rinse+** : • Used to additional rinse, which may assist in removing traces of detergent residue.
 • By selecting Rinse+ function, the rinse time and the rinse water are increased.

* **Crease Care** : • If you want to prevent crease, select this button with spin speed.

7. TROUBLESHOOTING

7-1. BEFORE PERFORMING SERVICE

- Be careful of electric shock or disconnecting the parts while troubleshooting.
- Voltage of each terminal in 220-240V~ and DC while applying an electric current.

7-2. QC TEST MODE.



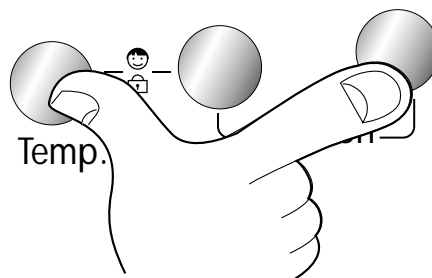































- ① Pressing **Temp.** and **Option** button simultaneously.
- ② Power supply ON with pressing upper two button.
- ③ Press the START/PAUSE button as follows.
[Press the START/PAUSE button more 4 times until stop spinning]



Pressing number of [START/PAUSE] button	Checking Point
None	All lamps turn on
1 time	Clockwise spin (right)
2 times	Low speed spin
3 times	High speed spin
4 times	Inlet valve for pre-wash operation
5 times	Inlet valve for main-wash operation
	Hot inlet valve in case of hot water fill
6 times	Inlet valve for main-wash operation
7 times	Counterclockwise spin (left)
8 times	A Heater is in operation for 3 sec.
9 times	Draining pump operation
10 times	Auto off operation



7-3.ERROR DISPLAY.



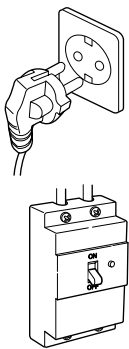

- If you press the [Start/Pause] button when an error is displayed, any error except **S/W ERROR** will disappear and the machine will change into pause status.
- In case of 『 **SENSOR PRESSURE S/W ERROR** 』, 『 **HEATING ERROR** 』, 『 **DOOR OPEN ERROR** 』, if the error is not resolved within 20 sec. In the case of other errors, if the error is not resolved within 4 min. power will be turned off automatically and the error code will be blinked. But in case of 『 **OVER FLOW ERROR** 』, power will not be turned off.

	ERROR	SYMPTOM	CAUSE
1	WATER INLET ERROR	 Rinse+  Crease Care	<ul style="list-style-type: none"> ○ Water has not reached to the pre-set level within 4 min. since inlet valve operated, or water has not reached to the normal level within 25 min.
2	IMBALANCE ERROR	 1000  800  400  No Spin  Rinse Hold	<ul style="list-style-type: none"> ○ The appliance is tilted. ○ Laundry is gathered to one side. ○ Non distributable things are put into the drum.
3	DRAIN ERROR	 Pre Wash  Time Save	<ul style="list-style-type: none"> ○ Water has not drained enough within 5 min.
4	OVERFLOW ERROR	 Pre Wash  Rinse+  Time Save  Crease Care	<ul style="list-style-type: none"> ○ Water is automatically being pumped out because too much water is in the tub.
5	SENSOR PRESSURE S/W ERROR	 95°C  Pre Wash  60  40  Time Save  30  Cold	<ul style="list-style-type: none"> ○ The sensor pressure switch is out of order.
6	DOOR OPEN ERROR	 95°C  Pre Wash  Rinse+  60  40  Time Save  Crease Care  30  Cold	<ul style="list-style-type: none"> ○ The [Start/Pause] button is pressed with the door open. ○ The door switch is out of order.
7	HEATING ERROR	 95°C  60  40  30  Cold	<ul style="list-style-type: none"> ○ The thermistor is out of order.

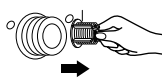
8. ERROR DIAGNOSIS AND CHECK LIST

8-1. DIAGNOSIS AND ANSWER FOR ABNORMAL OPERATION

SYMPTOM	GUIDE FOR SERVICE CALL
<p>NO POWER</p>	<div style="display: flex; justify-content: space-between;"> <div style="width: 65%;"> <p>Is the power plug connected firmly to 220-240V~ outlet?</p> <p style="text-align: center;">YES</p> <p>Power failure? or Breaker opened? Is the outlet controlled by a switch.</p> <p style="text-align: center;">NO</p> <p style="text-align: center;">Visit to check</p> </div> <div style="width: 30%; text-align: center;">  </div> </div>
<p>Water inlet trouble</p> <div style="border: 1px solid gray; padding: 5px; margin-top: 10px;"> <p>☀ Rinse+</p> <p>☀ Crease Care</p> </div>	<div style="display: flex; justify-content: space-between;"> <div style="width: 65%;"> <p>Is Rinse+ Crease Care displayed?</p> <p style="text-align: center;">YES</p> <p>Is the tap opened?</p> <p style="text-align: center;">YES</p> <p>Is the tap frozen?</p> <p style="text-align: center;">NO</p> <p>Is the water supply shut-off?</p> <p style="text-align: center;">NO</p> <p>Is filter in the inlet valve clogged with foreign material?</p> <p style="text-align: center;">NO</p> <p style="text-align: center;">Visit to check</p> </div> <div style="width: 30%; text-align: center;">  <div style="border: 1px solid gray; padding: 5px; margin-top: 10px; text-align: left;"> <p>Clean the filter of inlet valve</p>  </div> </div> </div>

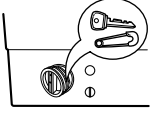
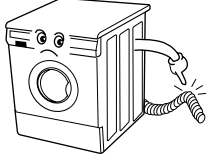
SYMPTOM	GUIDE FOR SERVICE CALL
<p>◦ DOOR OPEN ERROR</p> <p>Refer to 7-3 ERROR DISPLAY</p>	<div style="text-align: center;"> <p>Did you press the Start/Pause button when the door is open?</p> <p>YES → Close the door</p>  </div> <div style="text-align: center; margin-top: 20px;"> <p>NO</p> <p>↓</p> <p style="border: 1px solid black; border-radius: 15px; padding: 10px; display: inline-block;">Visit to check</p> <p>Check if the door switch is O.K</p> </div>
<p>◦ Drain Trouble</p> <div style="border: 1px solid gray; padding: 2px; display: inline-block; margin-top: 10px;">  Pre Wash </div> <div style="border: 1px solid gray; padding: 2px; display: inline-block; margin-top: 5px;">  Time Save </div>	<div style="text-align: center;"> <p>Is  Pre Wash  Time Save displayed?</p> <p>YES ↓</p> <p>Is the debris filter clogged with foreign material such as pins, coins, etc.?</p> <p>YES → Clean up the filter.</p>  </div> <div style="text-align: center; margin-top: 20px;"> <p>NO ↓</p> <p>Is the drain hose frozen with water, kinked, or crushed?</p> <p>NO ↓</p> <p style="border: 1px solid black; border-radius: 15px; padding: 10px; display: inline-block;">Visit to check</p>  </div>

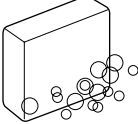
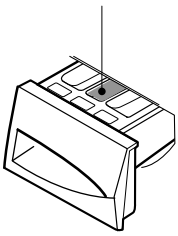
SYMPTOM	GUIDE FOR SERVICE CALL
<p>◦ Suds overflow from the appliance. (In this condition, wash and spin do not operate normally)</p>	<div style="display: flex; justify-content: space-between;"> <div style="width: 65%;"> <p>Is low-sudsing detergent for the drum washing machine used?</p> <p style="text-align: center;">YES</p> <p>Is the proper amount of detergent used as recommended?</p> <p style="text-align: center;">YES</p> <p>Recommend to reduce the amount of detergent.</p> <ul style="list-style-type: none"> * This appliance has the automatic suds sensing function which operates under much suds condition for good rinse and preventing overflow. * When much suds are sensed, the suds removing function such as drain, water input, and pause will operate without rotating the drum. </div> <div style="width: 30%; text-align: center;">  <p>LOW SUDSING DETERGENT</p> </div> </div>
<p>◦ No effect of softener</p>	<div style="display: flex; justify-content: space-between;"> <div style="width: 65%;"> <p>Is softener put in the correct compartment of drawer?</p> <p style="text-align: center;">YES</p> <p>Is the drawer closed during wash?</p> <p style="text-align: center;">YES</p> <p>Is the softener cap clogged?</p> <p style="text-align: center;">YES</p> <p style="text-align: center;">Explain how to use softener</p> <p style="text-align: center;">Clean the compartment for softener</p> </div> <div style="width: 30%; text-align: center;"> <p>Compartment for softener</p>  </div> </div>
<div style="display: flex; justify-content: space-between;"> <div style="width: 45%;"> <p>☀ Pre Wash ☀ Rinse+</p> <p>☀ Time Save ☀ Crease Care</p> </div> <div style="width: 50%; border-left: 1px dashed black; padding-left: 5px;"> <p>☀ 95°C</p> <p>☀ 60</p> <p>☀ 40</p> <p>☀ 30</p> <p>☀ Cold</p> </div> </div> <hr style="border-top: 1px dashed black;"/> <div style="display: flex; justify-content: space-between;"> <div style="width: 45%;"> <p>☀ 95°C ☀ Pre Wash ☀ Rinse+</p> <p>☀ 60</p> <p>☀ 40 ☀ Time Save ☀ Crease Care</p> <p>☀ 30</p> <p>☀ Cold</p> </div> </div>	<p style="text-align: center; border: 1px solid black; border-radius: 15px; padding: 10px; width: fit-content; margin: 0 auto;">Visit to check</p>

8-2.FAULT DIAGNOSIS AND TROUBLESHOOTING

CAUTION

1. Be careful of electric shock or disconnecting the parts while troubleshooting.
2. First of all, check the connection of each part terminal with wiring diagram.
3. If you replace the PWB assembly (Main), put in the connectors correctly.

NO POWER

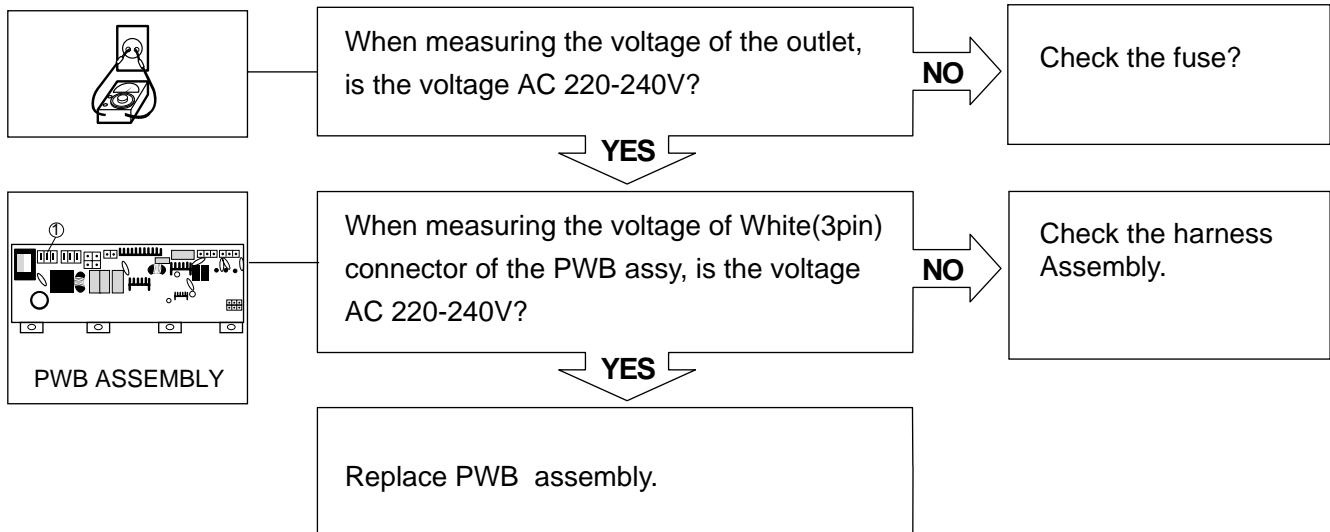

ALL BUTTONS ARE INOPERABLE EXCEPT POWER BUTTON

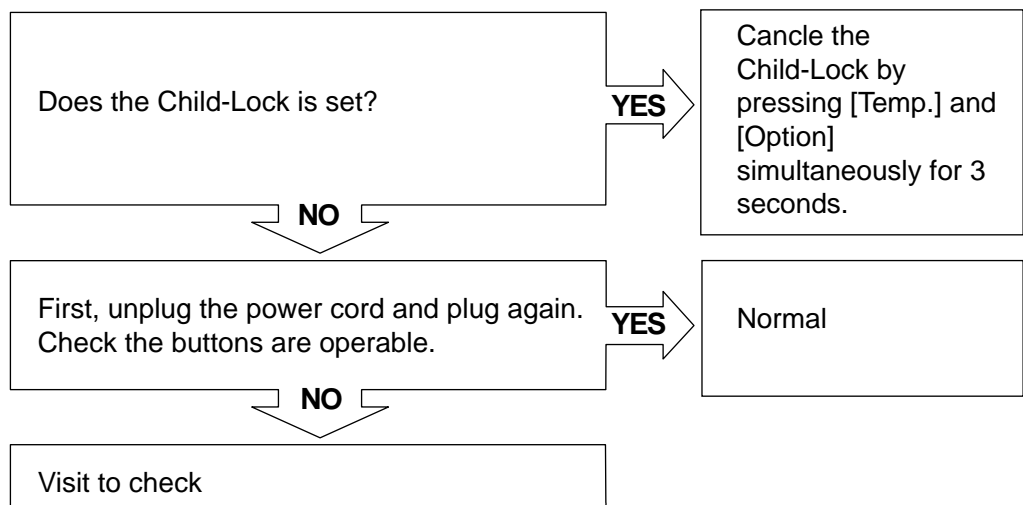

NO WATER SUPPLY

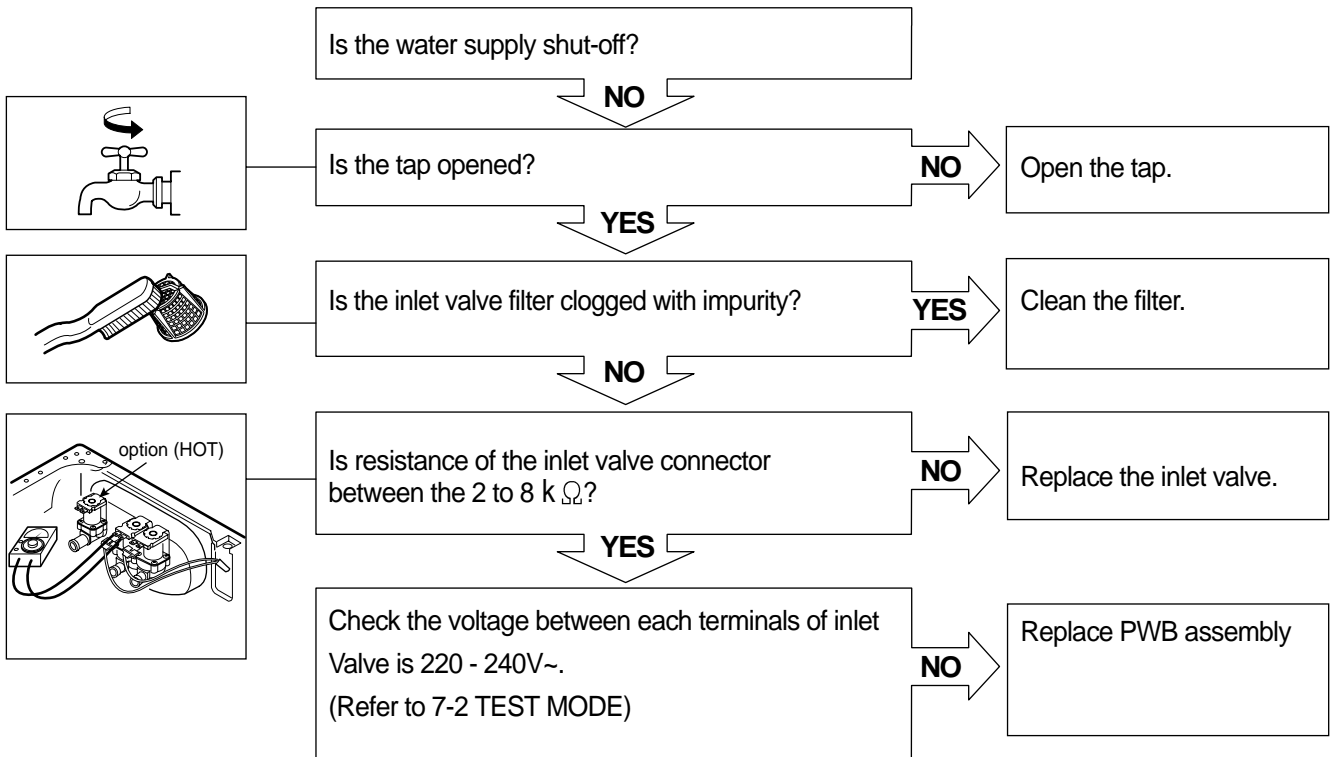

DETERGENT DOES NOT FLOW IN

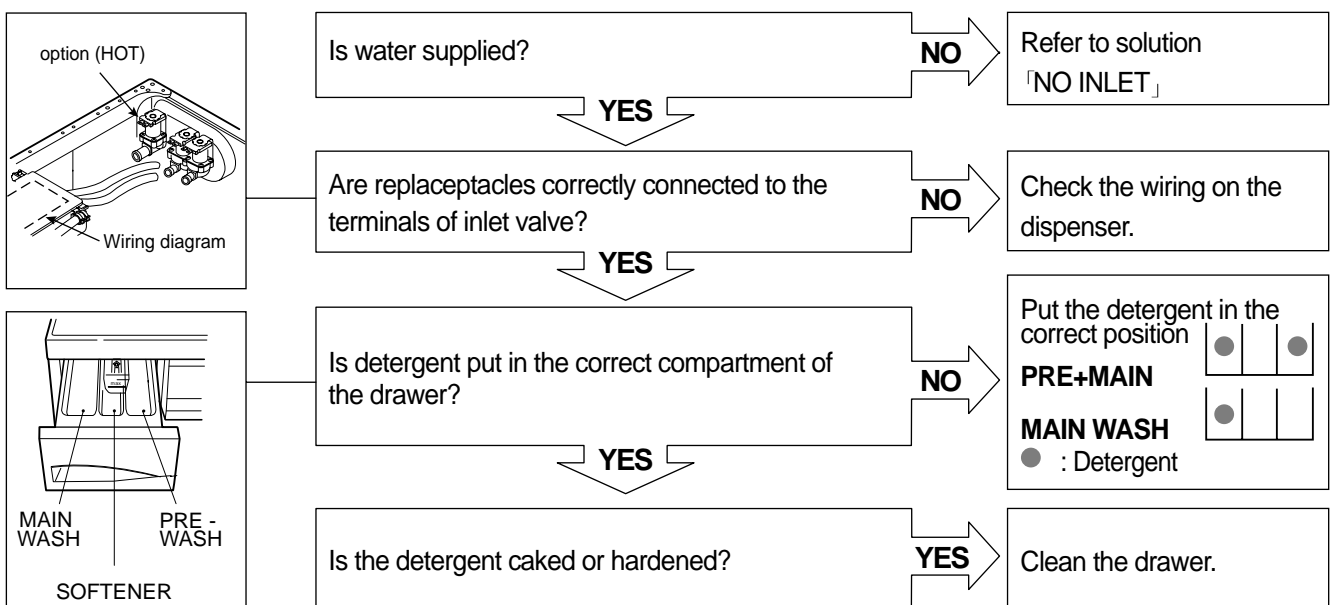

SOFTENER DOES NOT FLOW IN

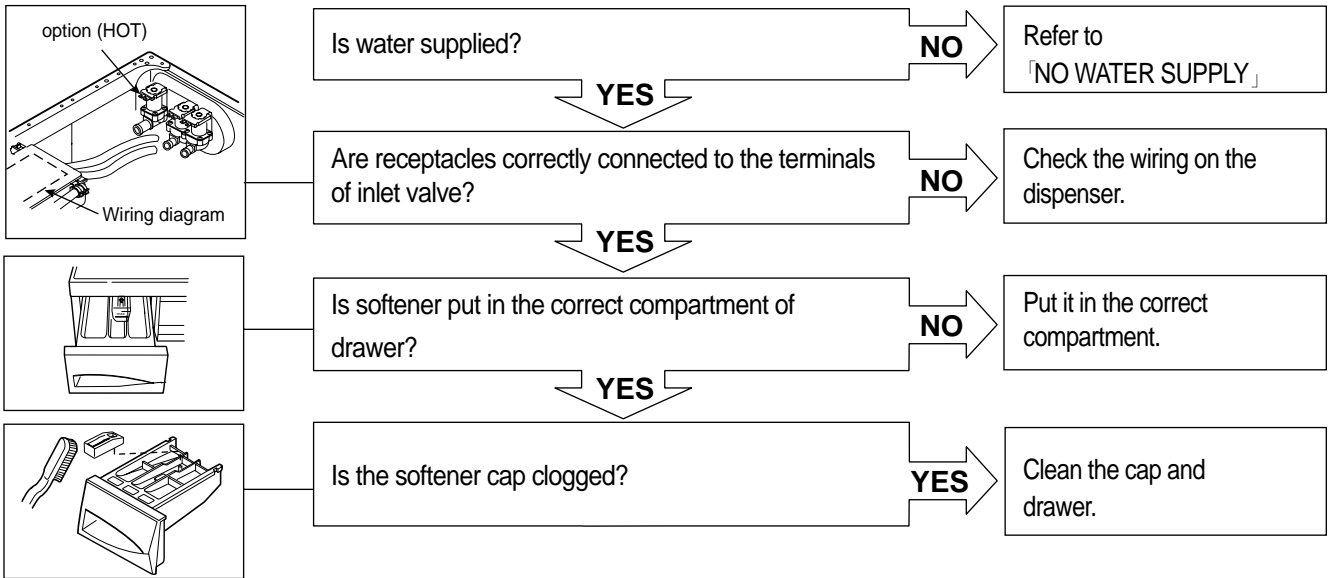

ABNORMAL SOUND

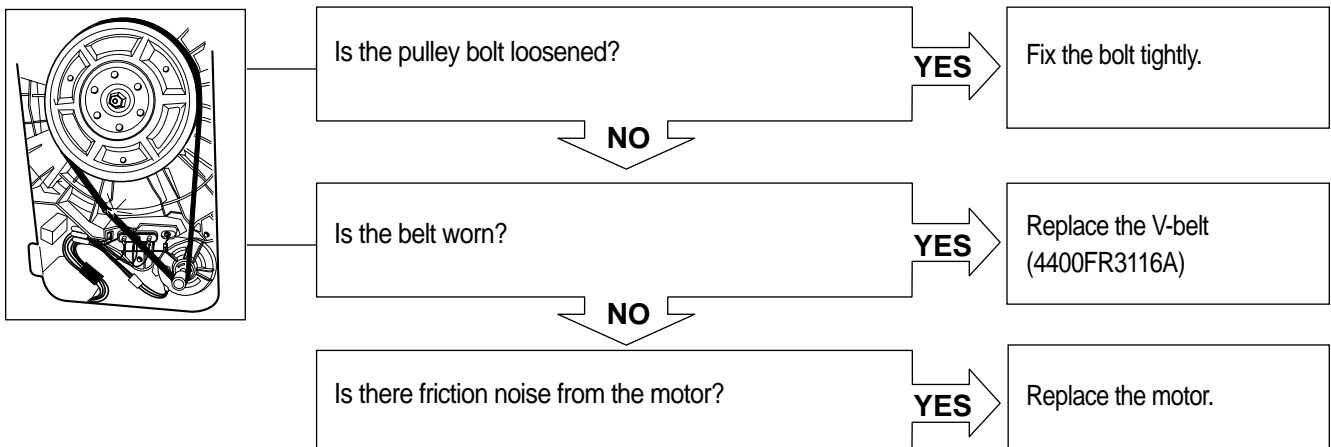

HEATING WITHOUT WATER

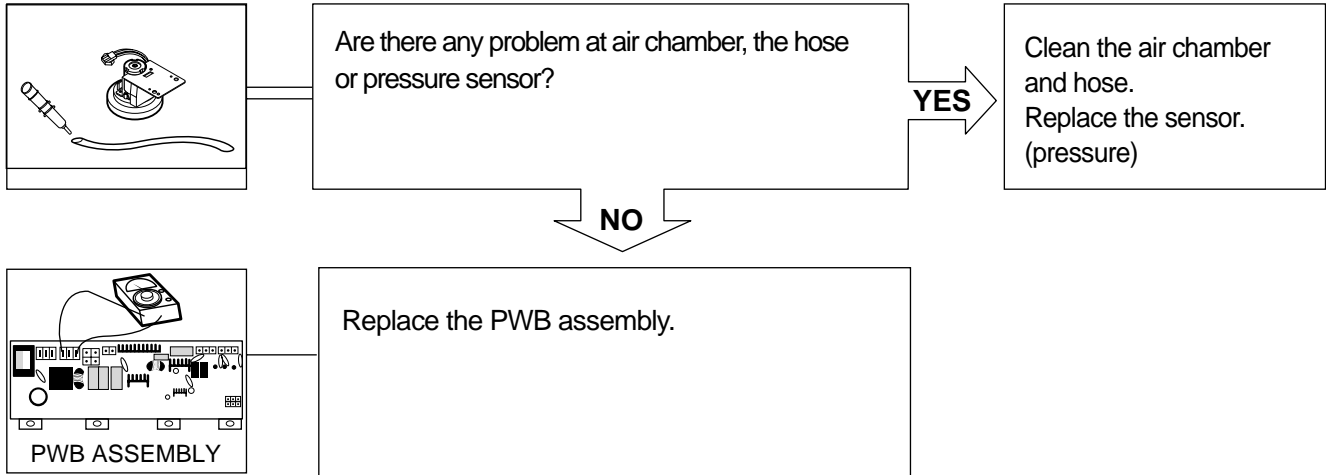

DRAIN MALFUNCTIONING

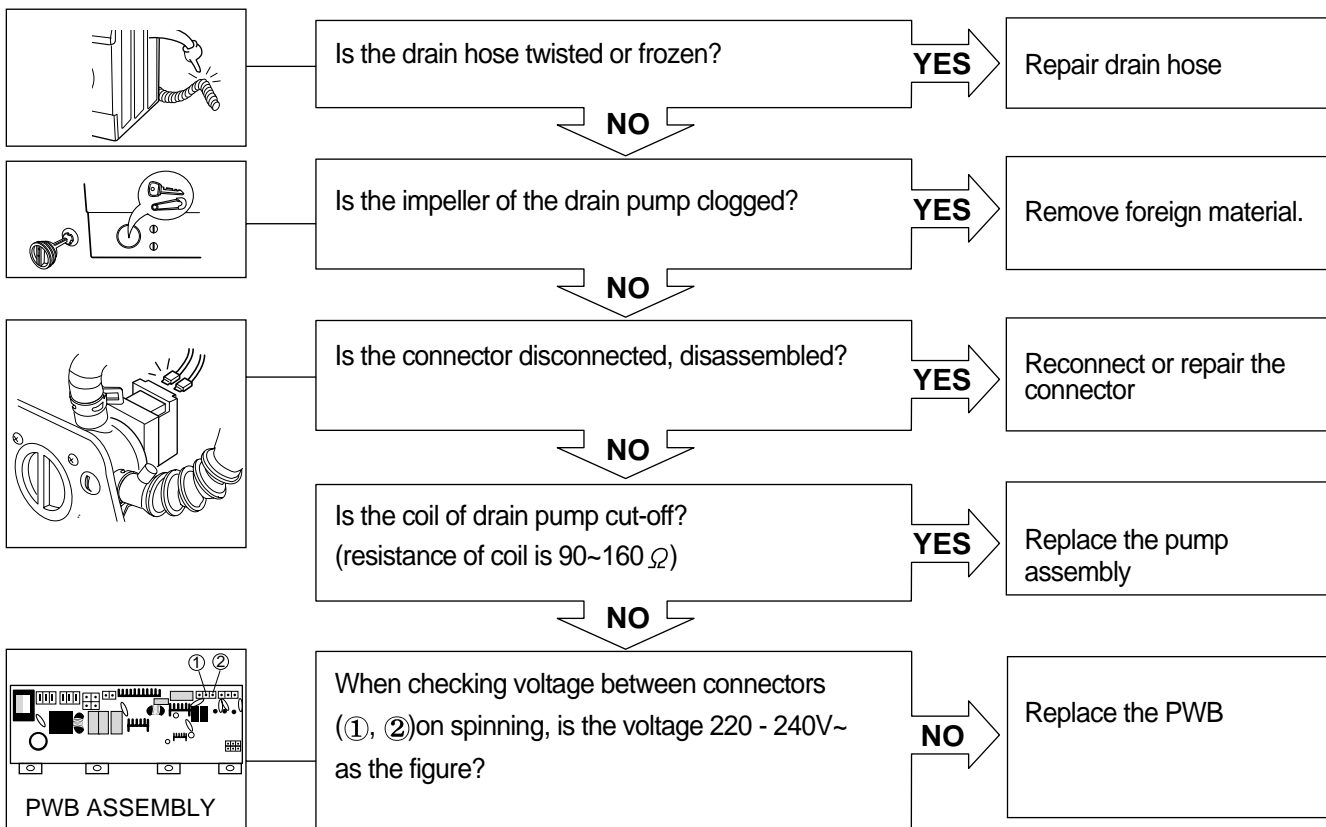

WASH HEATER TROUBLE

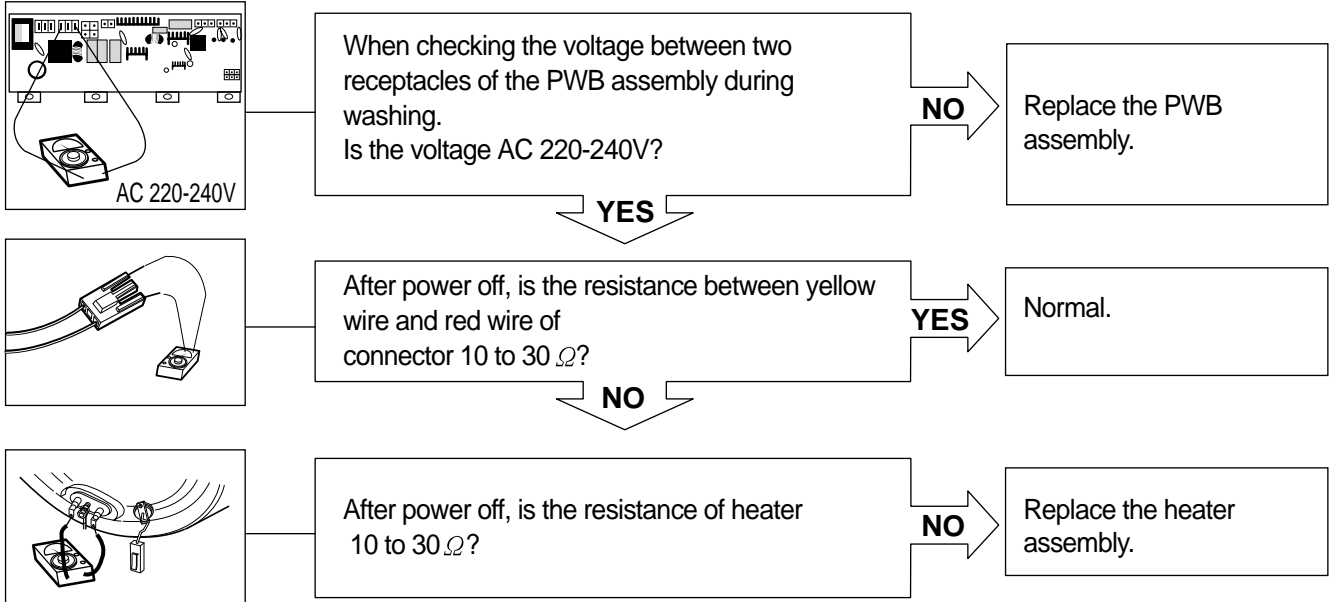

HEATING CONTINUOUSLY ABOVE THE SETTING WATER TEMPERATURE

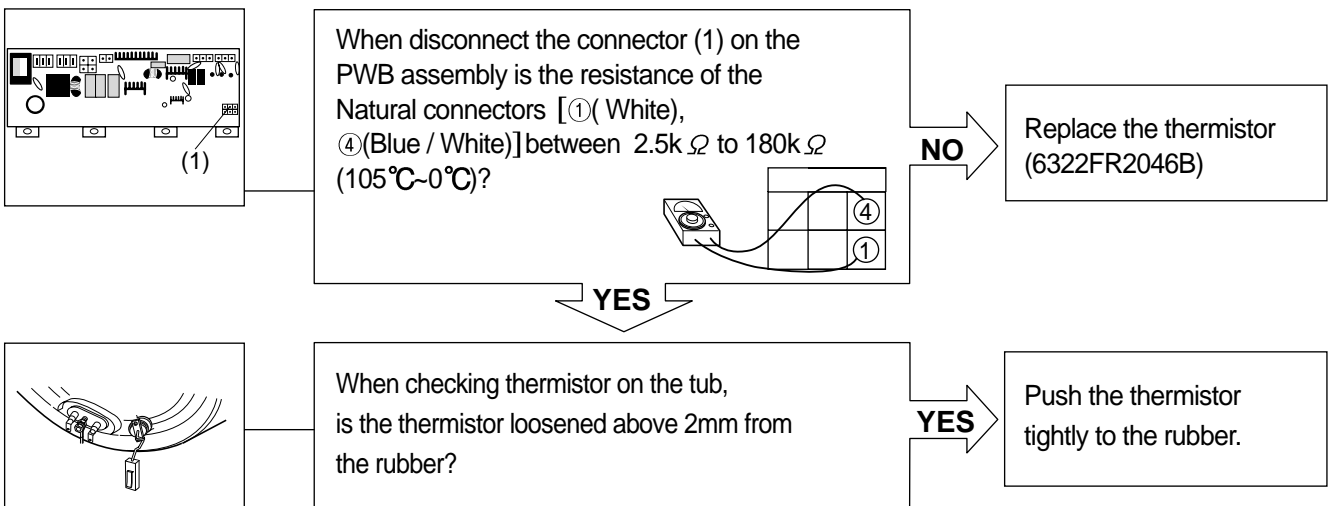

SPIN TROUBLE

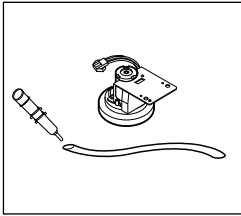

Check the sensor (Pressure) or hose (Sensor).
If the problem is on the sensor or the hose,
replace the sensor or the hose.

YES

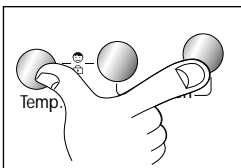

Press [Power] button with both [Temp.] and [Option]
buttons pressed after power off. Press [Start/Pause]
button 2 times. Does the drum rotate at low spin
speed?

YES

Normal.

NO

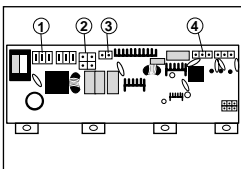

Is it disconnected or badly contacted?
[Red : 3pin (①), Natural : 4pin (②), White : 2pin(③),
Natural : 3pin(④)]

YES

Reconnect or repair it.

NO

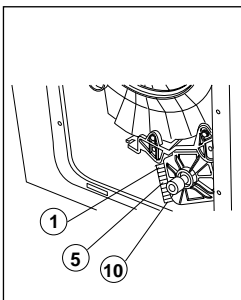

Check the motor connector, Is the resistance between
the terminal in figure the same as below?

Resistance between terminals

① ~ ⑤ : 0.5~1.0Ω

⑤ ~ ⑩ : 1.5~2.5Ω

Be sure to unplug the machine before measuring.

MOTOR TERMINAL

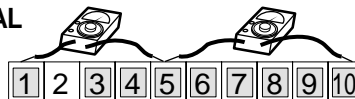

NO

Replace the motor
assembly.
(4681FR1194A) or
(4681FR1194B)

YES

Replace the PWB assembly.

9. DISASSEMBLY INSTRUCTIONS

* Be sure to unplug the machine out of the outlet before disassembling and repairing the parts.

CONTROL PANEL

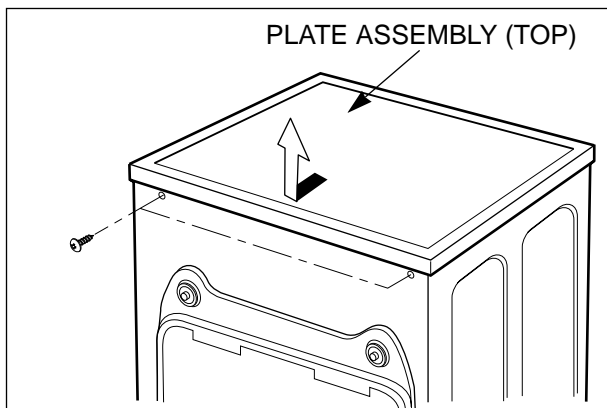

- ① Unscrew 2 screws on the back of the top plate.
- ② Pull the top plate backward and upward as shown.

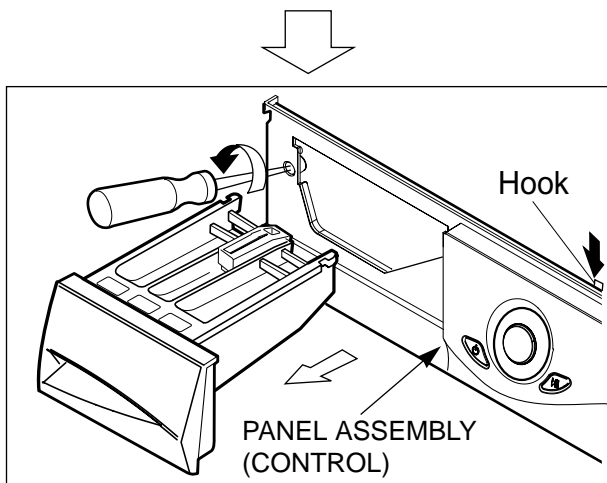

- ① Disconnect the PWB Assembly connector from Main lead wire Assembly.
- ② Pull out the drawer and unscrew 2 screws.
- ③ Push upper hooks down on the top and pull the control panel.

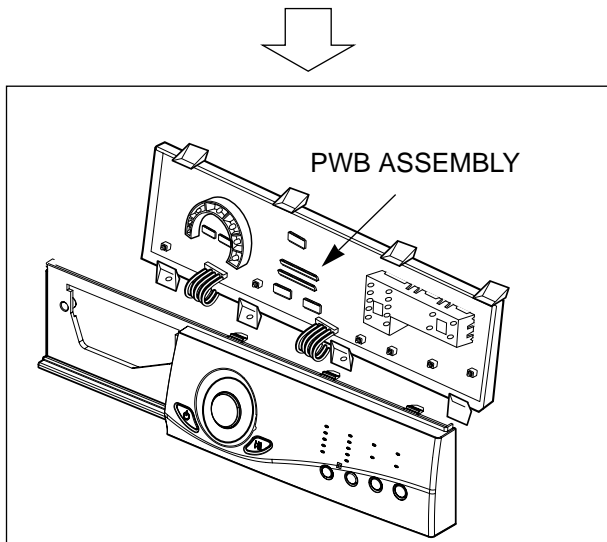

- ① Disconnect the PWB assembly from the control panel by pushing 4 hooks down.

DISPENSER ASSEMBLY

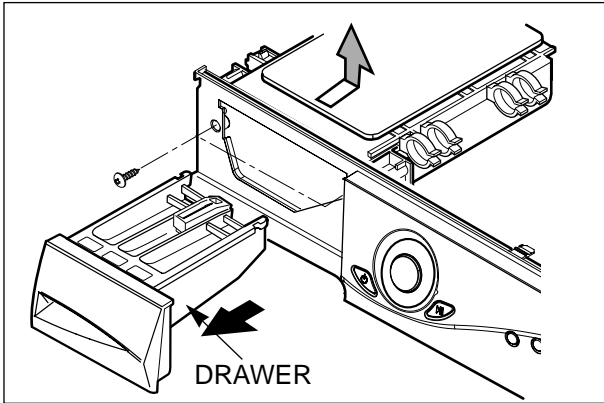

- ① Disassemble the top plate assembly.
- ② Pull out the drawer to arrow direction.
- ③ Unscrew 2 screws.

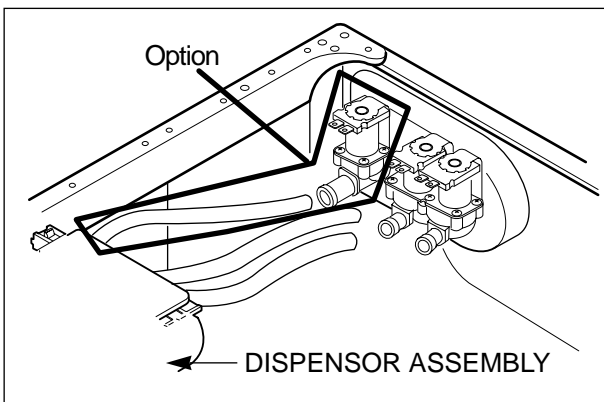

- ① The hose clamps and the hose are disassembled.
- ② The ventilation bellows and the water inlet bellows are disassembled on the tub.

INLET VALVE

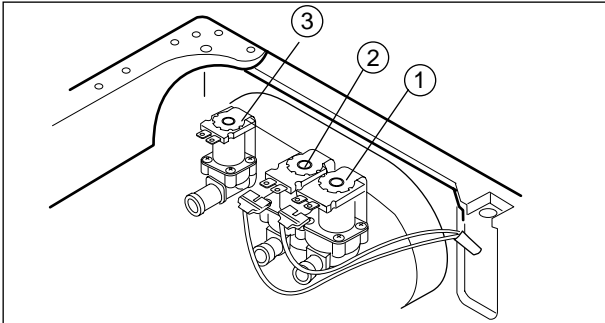

- ① Disconnect the wiring receptacle.
 - ② Unscrew 2 screws from the back.
- ※When reconnecting the connector

VALVE #1 (MAIN)	Whited/Black-Black
VALVE #2 (PRE)	Black - Gray
VALVE #3 (HOT)	Blue/White - Black

LOWER COVER

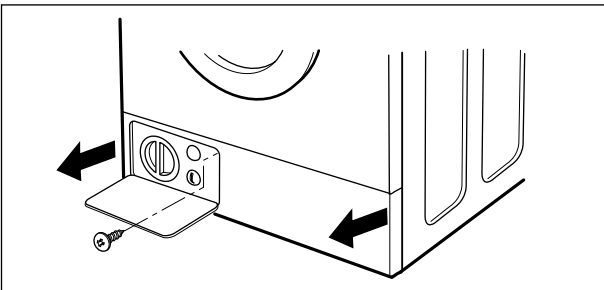

- Open the lower cover plate by using coin and pull out the lower cover in the arrow direction after a screw is unscrewed.

DOOR

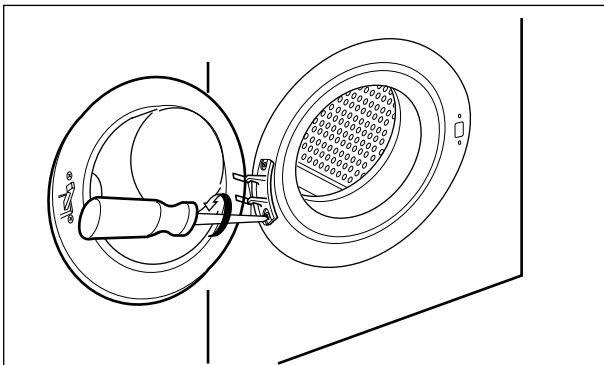

- ① Open the door completely.
 - ② Remove the two screws from the hinge.
- ※When removing the door assembly, it is necessary to hold the bracket that is inner of the cabinet cover.

GASKET ASSEMBLY

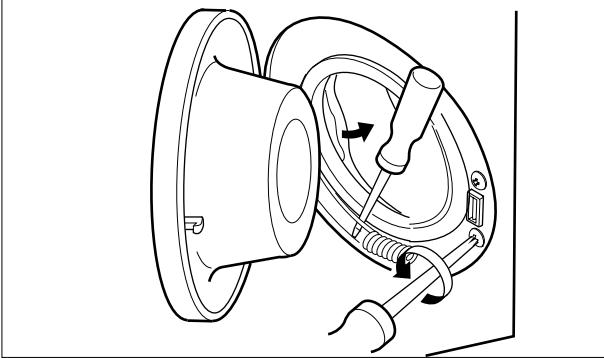

- ① Take apart the cabinet gasket clamp.
- ② Unscrew 2 screws from the cabinet cover.
- ③ Open the lower cover cap and unscrew 1 screw inside.
- ④ Take apart the lower cover.

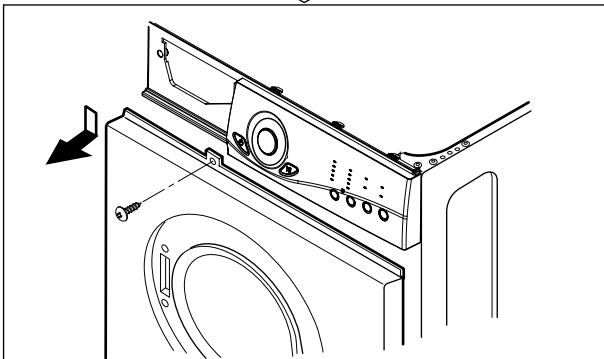

- ① Unscrew all the screws on the upper and lower sides of the cabinet cover.

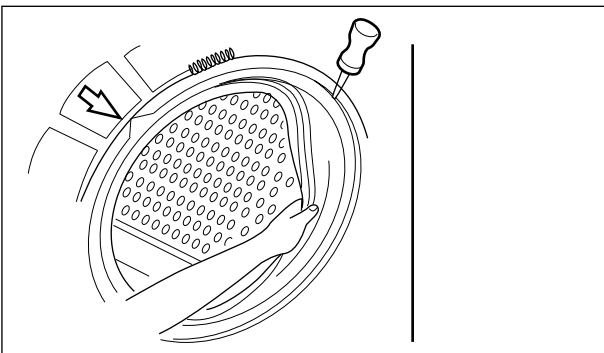

- ① Take apart the tub gasket clamp.
 - ② Make sure that the drain hole of the gasket is put beneath when reassembling the gasket.
- ※Refer to the arrow mark on the tub cover.

PULLEY, MOTOR, DAMPER

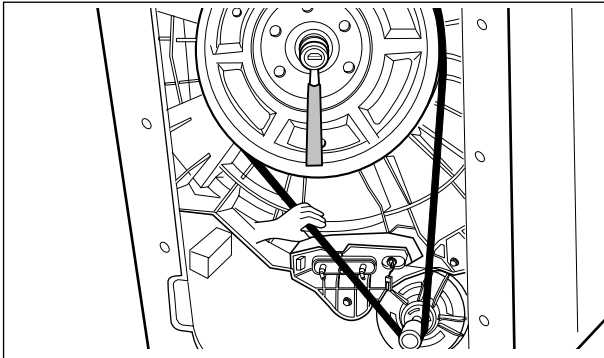

(PULLEY)

- ① Remove the back cover.
- ② Take off the belt turning the pulley.
- ③ Unscrew the bolt to pull out the pulley.

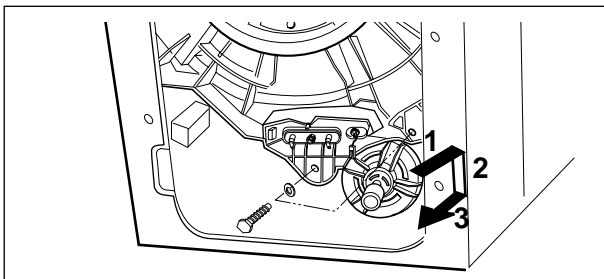

(MOTOR)

- ① Unscrew 2 screws from the bracket.
- ② Push the motor in the arrow direction for disassembling.
- ③ When reassembling the motor, make sure that motor mounting bushings are not taken off from the bracket.

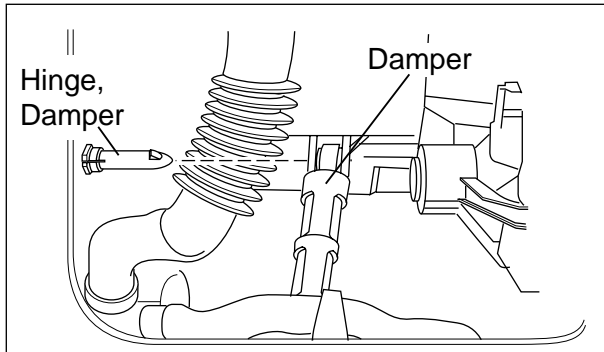

(DAMPER)

- ① Pull out the hinge, pressing its snap.
- ② Do not use the pulled out hinge again. It may be taken off during operation.

■ Clean the drain pump filter

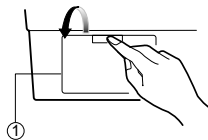

Open the lower cover cap (①) by using a finger. Turn the drain plug (②) to pull out the hose.

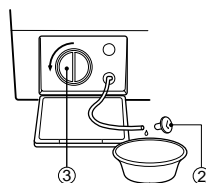

Unplug the drain plug (②), then the water flows out. At this time use a vessel to prevent water flowing on the floor. If the water does not flow any more, turn the pump filter (③) open to the left.

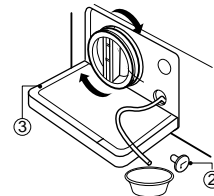

Take out any foreign material from the pump filter (③). After cleaning, turn the pump filter (③) clockwise and insert the drain plug (②) to the original place. Close the lower cover cap.

PUMP

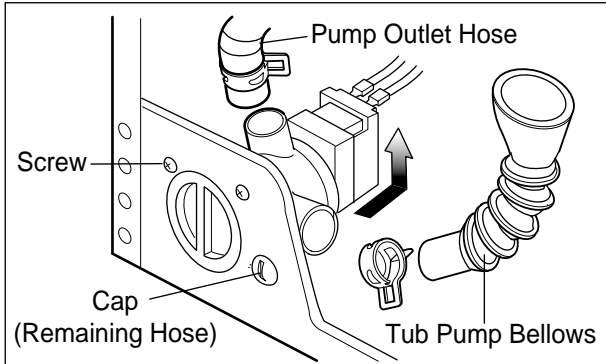

- ① Remove pump outlet hose.
- ② Remove tub pump bellows.
- ③ Remove cap (Remaining Hose.)
- ④ Disconnect the wiring.
- ⑤ Unscrew 2 screws.
- ⑥ Remove the pump.

HEATER

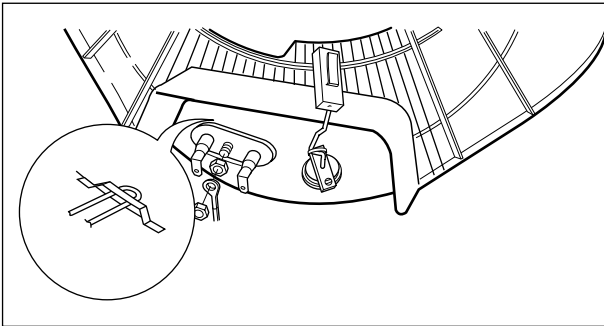

- ① Loosen the M6 heater nut to pull out the heater.

CAUTION

When mounting the heater, be sure to insert the heater into the heater clip on the bottom of the tub.

THERMISTOR

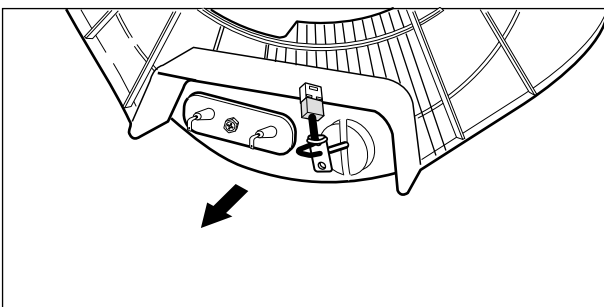

- ① Pull it out by holding the thermistor bracket.
 - * If it is pulled by the wire, it may be broken.
- ② When mounting the thermistor again, make sure that it is got back tight to the bushing.

SWITCH ASSEMBLY, DOOR LOCK

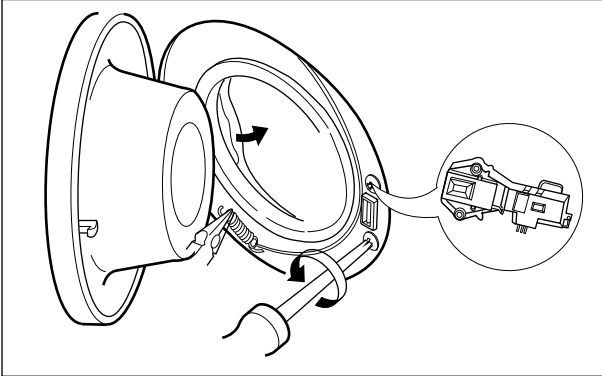

- ① Take apart the cabinet cover clamp and release the gasket.
- ② Unscrew 2 screws holding the door lock.
- ③ Disconnect the door lock from the wiring connector.

WHEN FOREIGN MATERIAL IS STUCK BETWEEN DRUM AND TUB

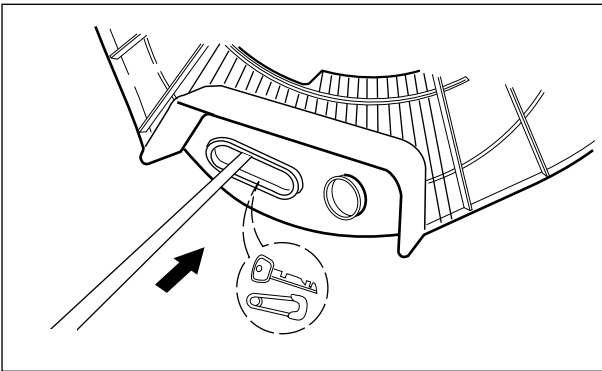

- ① Remove the heater.
- ② Remove the foreign material (wire, coin and others) by inserting a long bar through the hole.

10. EXPLODED VIEW

10-1. THE EXPLODED VIEW OF CABINET ASSEMBLY

○ : Service Part

○ : Non-Service Part

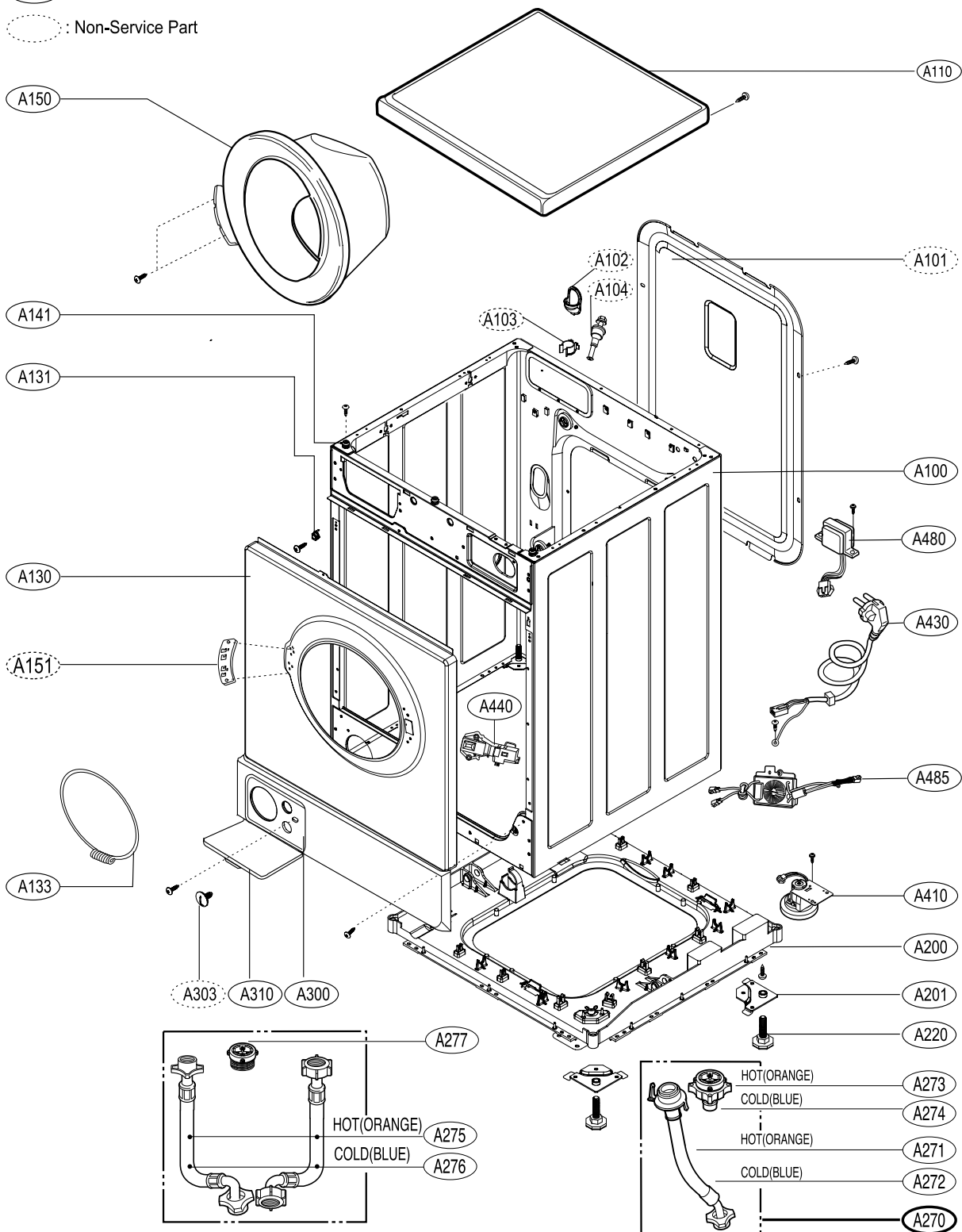

10-2 THE EXPLODED VIEW OF CONTROL PANEL & DISPENSER ASSEMBLY

○ : Service Part
○ : Non-Service Part

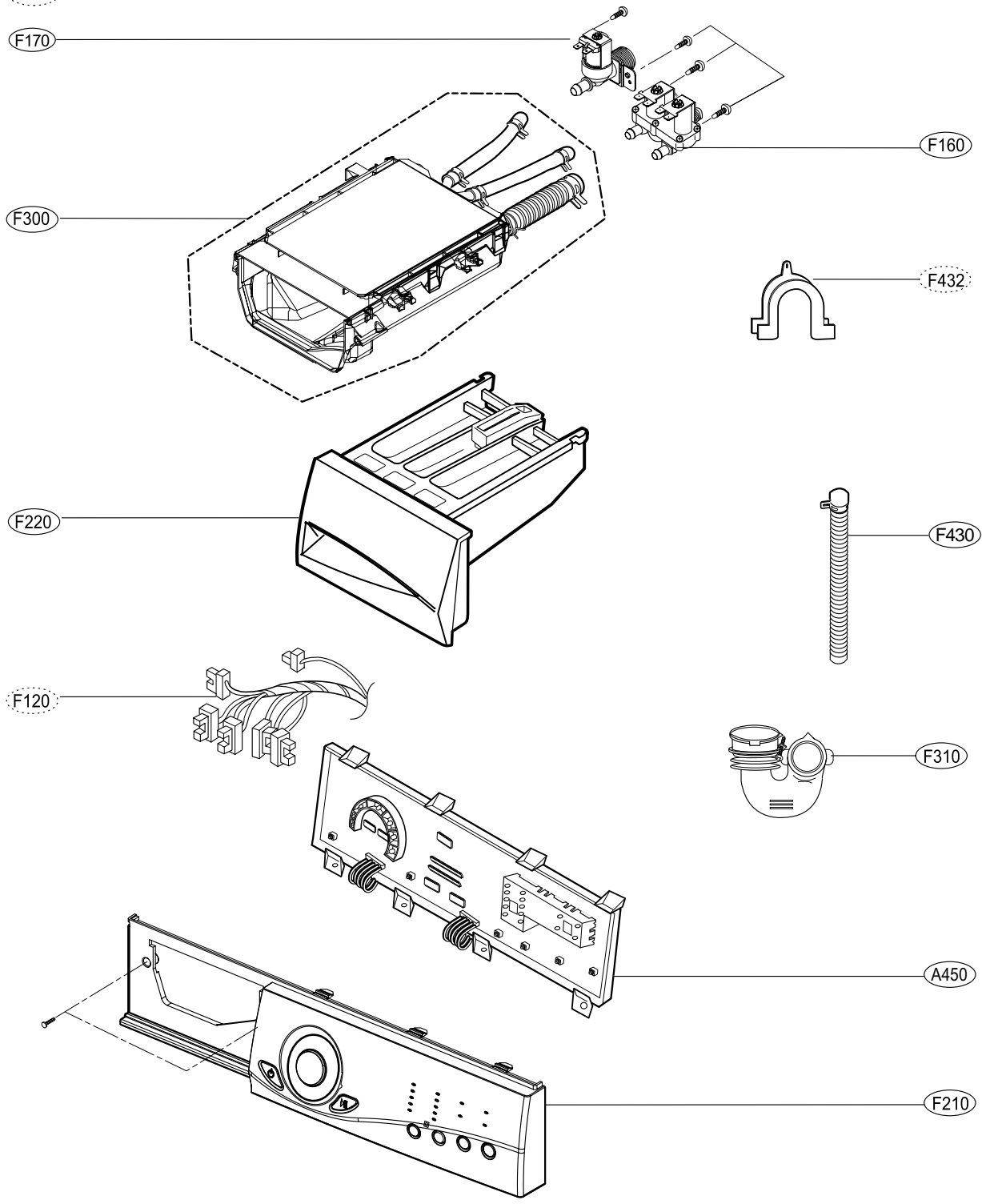



LG Electronics Inc.

Mar. 2002 PRINTED IN KOREA

P/No.:3828ER3013A

Free Manuals Download Website

<http://myh66.com>

<http://usermanuals.us>

<http://www.somanuals.com>

<http://www.4manuals.cc>

<http://www.manual-lib.com>

<http://www.404manual.com>

<http://www.luxmanual.com>

<http://aubethermostatmanual.com>

Golf course search by state

<http://golfingnear.com>

Email search by domain

<http://emailbydomain.com>

Auto manuals search

<http://auto.somanuals.com>

TV manuals search

<http://tv.somanuals.com>