

*MSO LOGO HERE*



## *Motorola Set-Up Guide*

> *DCT6200* > *DCT6208*

*HIGH-DEFINITION TELEVISION*

# INTRODUCTION

## WELCOME TO THE HIGH-DEFINITION EXPERIENCE

*Congratulations on receiving a new DCT6200/DCT6208 High-Definition cable box. The Motorola DCT6200/DCT6208 is the most advanced digital consumer terminal available today. The powerful processing capability of the cable box delivers crystal-clear video, Dolby 5.1 surround sound audio and advanced interactive applications to your living room.*



*This cable box is capable of much more than just delivering hundreds of analog and digital video channels. It provides exciting services such as High-Definition video, Dolby 5.1, electronic program guide, commercial-free digital music, ON DEMAND and much more.*

*This Set-Up Guide introduces you to the basic features of the DCT6200/DCT6208 and provides several options for integrating it into your current entertainment system. For more detailed configuration information, please visit [www.yourmsoweb.com](http://www.yourmsoweb.com).*

## IMPORTANT SAFETY INSTRUCTIONS

The Motorola DCT6200/DCT6208 has been designed to operate reliably in a well-ventilated household environment. Slots and openings in the unit cabinet are provided for ventilation. These openings should never be blocked by placing the product on a bed, sofa, rug, or similar surface. The unit should be positioned with at least 2 inches of space above and on all sides.



- Position the cable box with at least 2 inches of space above and on all sides.
- Do not block the slots and openings in the cable box.
- Do not place anything on top of the cable box.
- Do not position the cable box in an enclosed space that would restrict airflow around the unit.
- Do not position the cable box near any external heat source that could raise the temperature around the unit.

## THE DCT6200/DCT6208 FRONT PANEL

The cable box front panel has 12 keys and an LED display. Use the keys to perform basic functions such as access to the electronic program guide and to navigate menus. The table following this drawing describes each key and its use.

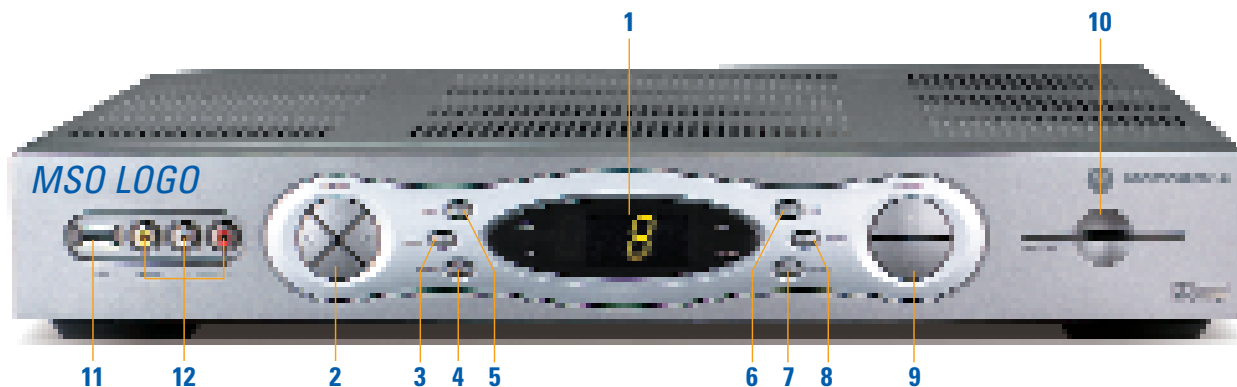

<b>Key</b>	<b>Description</b>
<b>1</b> LED	Displays the channel number or time of day.  There are four indicator lights on the LED screen: <ul style="list-style-type: none"> <li>• MSGS. — the cable box has received messages for you to read</li> <li>• ON — the cable box is powered on</li> <li>• A/B — the RF bypass is active</li> <li>• REMOTE — the remote control is in use</li> </ul>
<b>2</b> ▲▼◀▶ CURSOR	Moves the cursor around the program guide and menu screens.
<b>3</b> MENU	Displays the main menu.
<b>4</b> POWER	Turns the device on or off.
<b>5</b> INFO	Displays the current channel and program information.
<b>6</b> A/B	Use to manually enable the RF bypass function. You must have a cable-ready TV for this function to operate. (Optional.)
<b>7</b> SELECT	Selects menu options, ON DEMAND programming, events or programs from the program guide.
<b>8</b> GUIDE	Displays the program guide.
<b>9</b> CHANNEL + CHANNEL -	Changes the channels by moving up or down.
<b>10</b> SMART CARD SLOT	Not currently enabled – intended for future use.
<b>11</b> USB Port	Not currently enabled – intended for future use.
<b>12</b> Video/Audio Inputs	Not currently enabled – intended for future use.

# THE DCT6200/DCT6208 BACK PANEL

The rear panel of the cable box consists of three types of interfaces — audio, video and data. The table following this drawing describes each connection and its use.

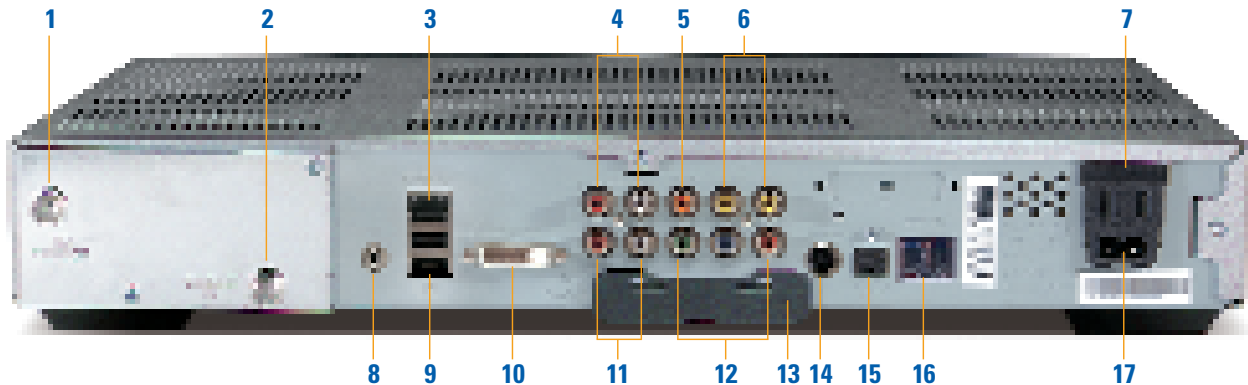

KEY	DESCRIPTION
<b>1</b>	<b>TO TV/VCR</b> This coaxial output connector is used to connect the cable box to a TV or VCR operating on channel 3 or 4.
<b>2</b>	<b>CABLE IN</b> The CABLE IN connector receives the incoming signal from your cable service provider.
<b>3</b>	<b>ETHERNET</b> Not currently enabled – intended for future use.
<b>4</b>	<b>AUDIO IN R AUDIO IN L</b> These connectors are used to connect a set-top between a peripheral audio device such as a CD player and a stereo tuner or A/V receiver. In the current cable box release, the audio from the peripheral device will pass through the cable box when it is turned off.
<b>5</b>	<b>SPDIF</b> The orange coaxial SPDIF connector is a digital output connection that carries Dolby Digital 5.1 audio or PCM audio. It is used to connect the cable box to a stereo tuner or A/V receiver to provide surround-sound, theater-style audio.
<b>6</b>	<b>VIDEO IN VIDEO OUT</b> The VIDEO IN connector accepts a baseband video input from a VCR, camcorder or other video device. (Not currently enabled.) The VIDEO OUT connector is used to deliver baseband video to an external device such as a VCR or TV.
<b>7</b>	<b>OUTLET</b> This AC outlet may be used to plug your TV into the cable box as a convenient additional outlet.
<b>8</b>	<b>IR</b> This connector enables the cable box to control a VCR while recording a selected program. Not all electronic program guides support this feature.
<b>9</b>	<b>USB</b> Not currently enabled – intended for future use.
<b>10</b>	<b>DVI-D</b> Digital Video Interface. To connect high definition monitor or high definition television.
<b>11</b>	<b>AUDIO OUT R AUDIO OUT L</b> The RCA phono-type connectors are used to deliver audio to a stereo receiver.
<b>12</b>	<b>Y Pb Pr</b> These connectors are used to deliver component video to an HD-ready TV or monitor. Though capable of delivering standard definition video to your TV or monitor, these cables are necessary to deliver High Definition video.
<b>13</b>	<b>TV PASS CARD</b> For Future Use.
<b>14</b>	<b>S-VIDEO</b> This connector is used to deliver high quality, standard definition video to external devices that accept S-Video inputs, such as a high-end VCR or TV.
<b>15</b>	<b>OPTICAL SPDIF</b> The OPTICAL SPDIF connector is an optical digital output connection that carries Dolby Digital 5.1 audio or PCM audio. It is used to connect the cable box to a stereo tuner or A/V receiver to provide surround-sound, theater style audio.
<b>16</b>	<b>IEEE 1394</b> Firewire Digital Interface to connect high definition monitor or high definition television.
<b>17</b>	<b>POWER INLET</b> For the female end of the supplied power cord.

## Connecting the DCT6200/DCT6208 to a High-Definition TV – Video Only

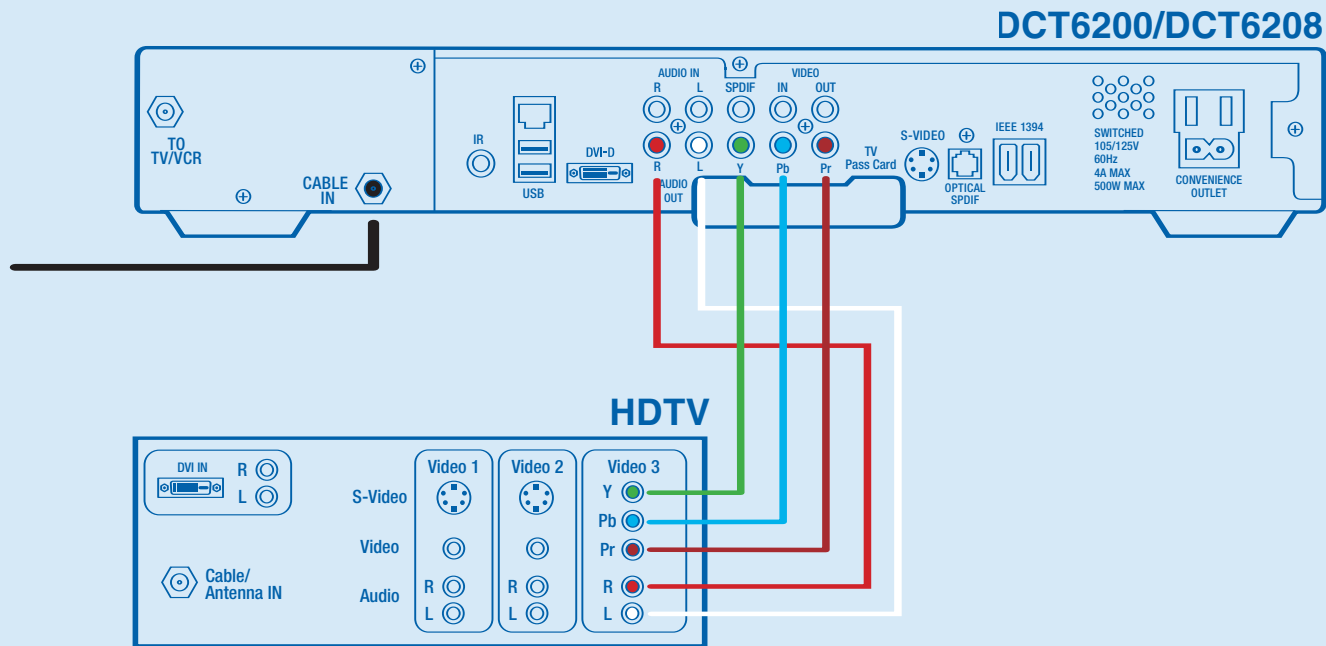

Do not plug the DCT6200/DCT6208 power cord into a wall outlet until you have completed all connections between the DCT and other components.

*This diagram shows the High-Definition video connection between your Motorola DCT6200/DCT6208 and your High-Definition television (HDTV). This is the primary diagram for providing HD video and should be done prior to the following audio configurations.*

*Connector cables to be used:*

- 6 ft coaxial cable
- Three-pronged component video cable

1. Using a coaxial cable, connect cable wall outlet to the CABLE IN coaxial input on the cable box.
2. Locate the Y Pb Pr inputs on your HDTV and the Y Pb Pr outputs on the cable box. To make identification easy, these connectors are color-coded on the cable box (Y = green, Pb = blue, and Pr = red). Colors may vary on your HDTV.
3. Using a three-jack component video connector, connect the Y output on the cable box to the Y input on your HDTV. Do the same for the Pb and Pr connections.

## Connecting the DCT6200/DCT6208 to a High-Definition TV – Audio Only

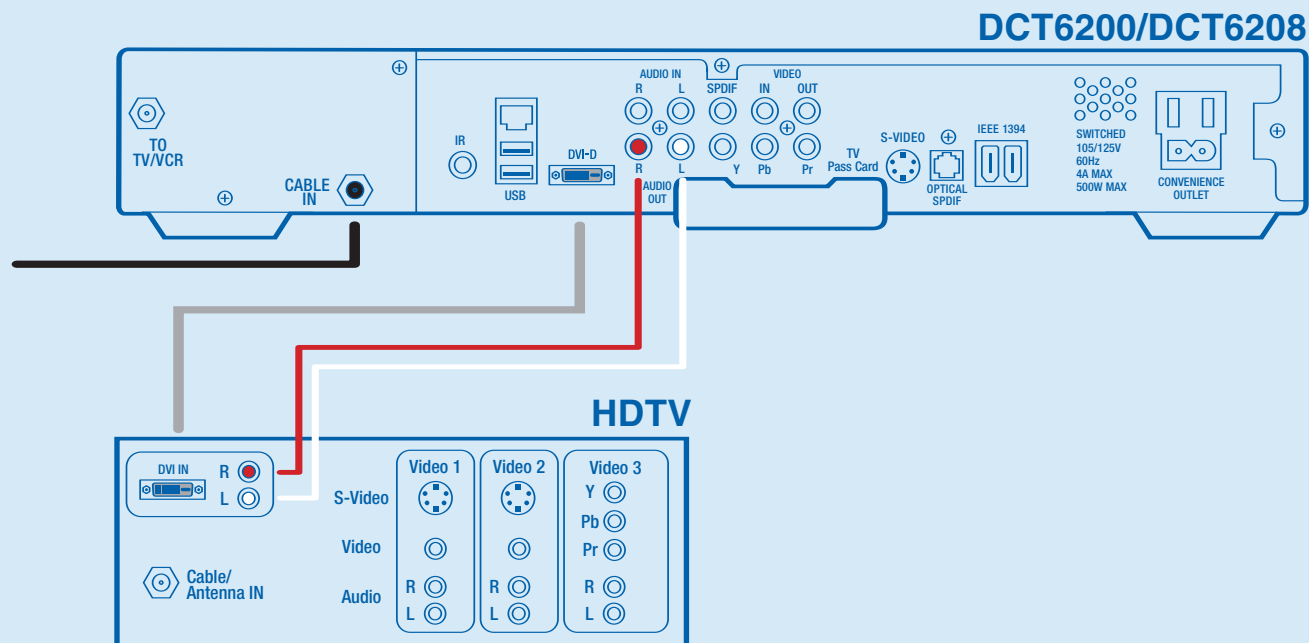

Do not plug the DCT6200/DCT6208 power cord into a wall outlet until you have completed all connections between the DCT and other components.

*This diagram shows the primary audio connection from your DCT6200/DCT6208 to your HDTV. You should use this configuration only if your HDTV has built-in speakers and you do not intend to include a stereo or Home Theater receiver in your configuration.*

Connector cables to be used: Two-pronged RCA type audio cable (red & white)

1. Locate the AUDIO OUT L (white) & R (red) outputs on the cable box and the AUDIO IN L & R inputs on your HDTV.
2. Using a two-pronged RCA type audio connector, connect the L (white) output on the cable box to the L (white) input on your HDTV. Do the same for the red.

If your HDTV offers digital audio inputs you may use the SPDIF or Optical SPDIF outputs on the cable box to connect the audio.

# Connecting the DCT6200/DCT6208 to a High-Definition TV and VCR

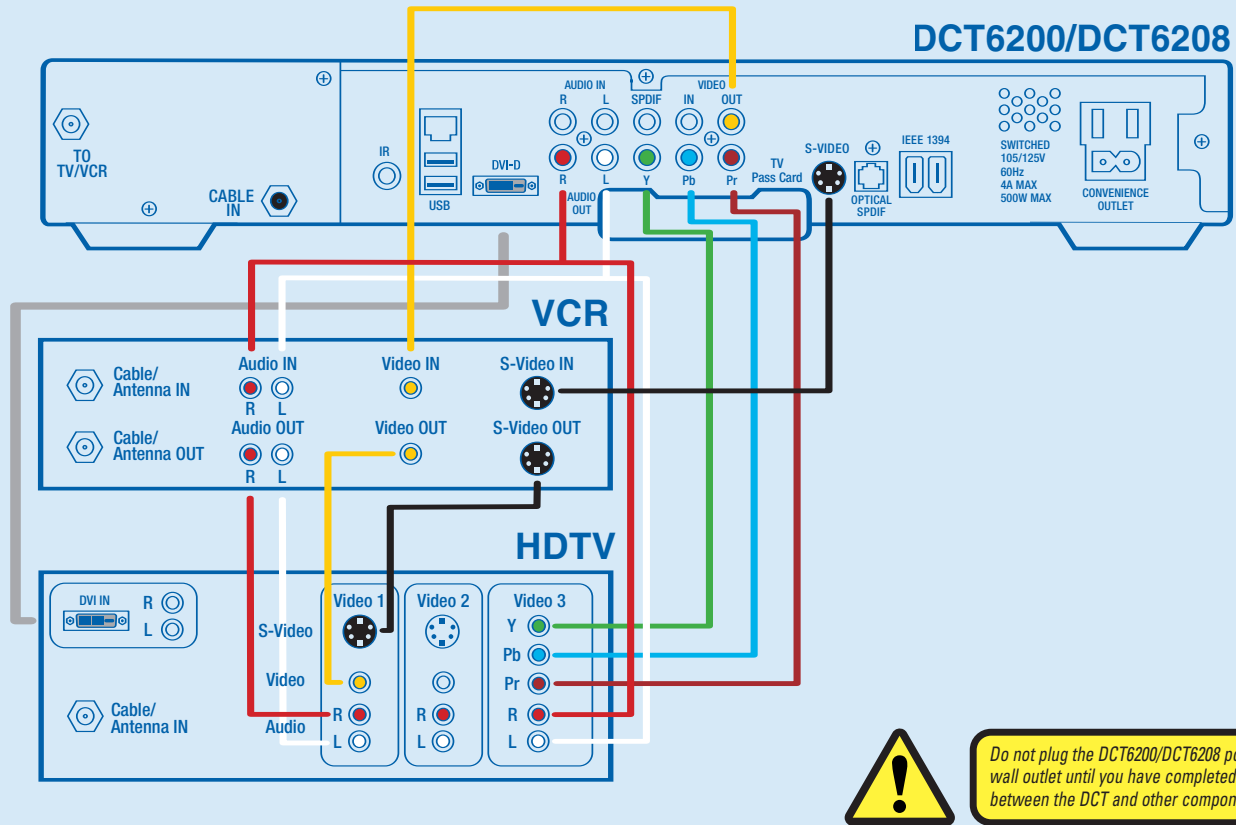

Do not plug the DCT6200/DCT6208 power cord into a wall outlet until you have completed all connections between the DCT and other components.

*This diagram should be used if you intend to use a standard stereo VCR in your configuration. This configuration will allow you to watch both HD and Standard Definition video on your HDTV as well as record and play Standard Definition video via your VCR.*

- Using the Video Only diagram, connect your coaxial cable to the Motorola cable box and the cable box Y Pb Pr HD video connection directly to your HDTV.  
Connector Cables to be used (not all cables included):
  - 1 set of two-pronged RCA type audio cables (red & white)
  - 2 sets of "Y" audio splitter cables
  - 2 S-video cables – OR – 2 sets of single-pronged RCA type video cables (yellow)

Note: The video cables you use will depend on the inputs/outputs on your VCR and HDTV. S-video is considered the higher standard definition video output and should be your first choice.
- Connect the single connector end of a Y audio splitter cable to the AUDIO OUT R (red) on the cable box. Insert the other ends into the AUDIO IN R on your VCR and AUDIO IN R on your HDTV.
- Use the second splitter cable to connect the AUDIO OUT L (white) on the cable box to the AUDIO IN L connections on both the VCR and the HDTV.
- Use the two-pronged RCA cable to connect the AUDIO OUT L & R on your VCR to the AUDIO IN L & R on your HDTV.
- Using an S-video cable, connect the S-VIDEO output on the cable box to the S-VIDEO IN on your VCR. Then use the second S-video cable to connect the S-VIDEO output on the VCR to the S-VIDEO IN on your HDTV.  
– OR –
- Using your single-pronged RCA type video connector cable, connect the VIDEO OUT (yellow) connector on the cable box to the VIDEO IN connector on your VCR. Next, use the second single-pronged RCA type video connector cable to connect the VIDEO OUT connector on your VCR to the VIDEO IN connector on your HDTV.



# Connecting the DCT6200/DCT6208 to a High-Definition TV and Home Theater

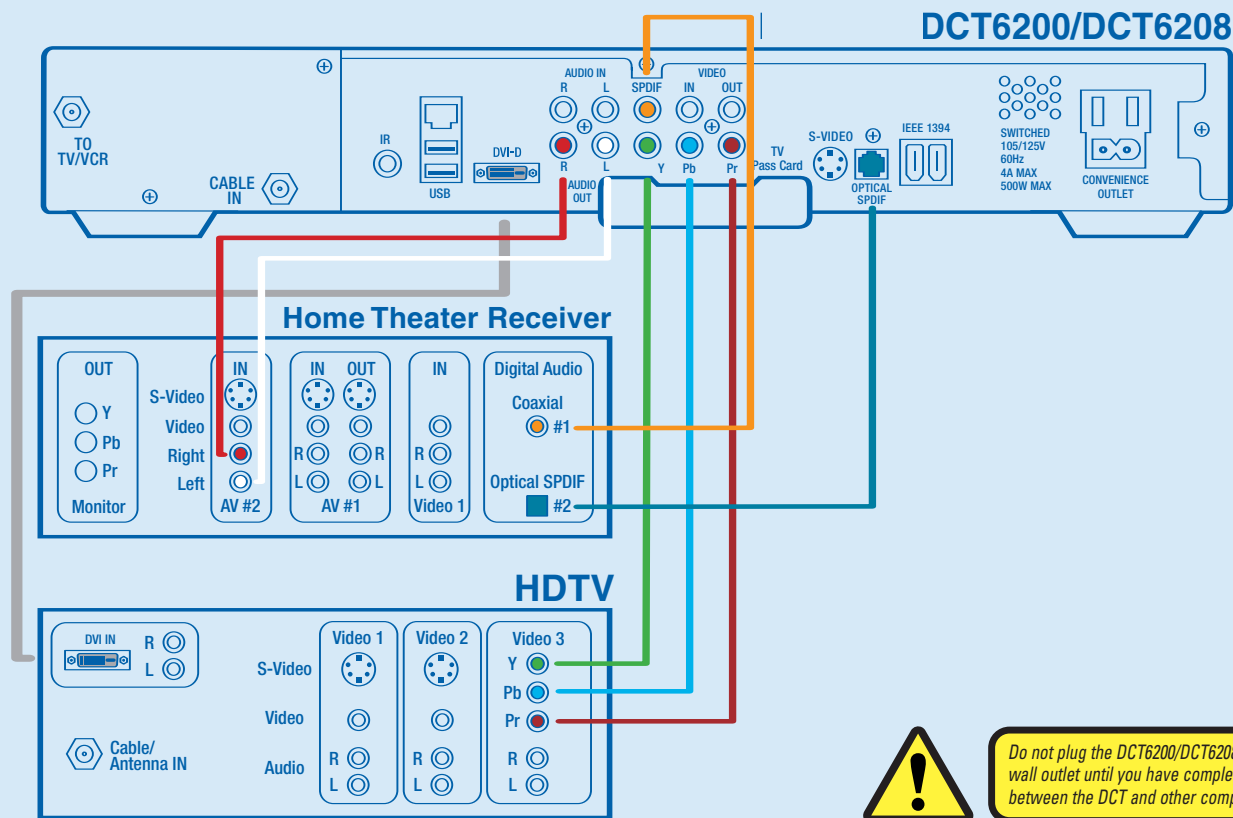

Do not plug the DCT6200/DCT6208 power cord into a wall outlet until you have completed all connections between the DCT and other components.

To take full advantage of the DCT6200/DCT6208 digital audio features you'll want to incorporate a stereo or Home Theater receiver. This diagram illustrates how to integrate your DCT6200/DCT6208, Home Theater receiver and HDTV. We have not illustrated how to integrate a VCR or DVD player with a Home Theater receiver. The manual supplied with these components would best describe those connections.

- Using the Video Only diagram, connect your coaxial cable to the Motorola cable box and the cable box Y Pb Pr HD video connection directly to your HDTV.

The audio options are dependent on the audio inputs available on your Home Theater receiver. We've listed them in order of sound quality.

#### **OPTION ONE and TWO** – Optical or RCA Type Digital Audio (orange)

(These two connections are of similar quality. Either one or the other may be used.)

Connector cables to be used: Optical or RCA type audio cable

- Locate the OPTICAL SPDIF output on the cable box and the OPTICAL SPDIF input on your digital Home Theater receiver.

This input may also be labeled Toslink on your digital Home Theater receiver.

- Using an optical audio connector, connect the output on the cable box to the input on your digital Home Theater receiver.

– OR –

- Locate the orange RCA type SPDIF output on the cable box and the RCA type SPDIF or digital audio input on your Home Theater receiver.

- Using a single-pronged RCA type audio connector, connect the output on the cable box to the input on your Home Theater receiver.

#### **OPTION THREE** – Baseband Audio

Connector cables to be used: Two-pronged RCA type audio cable (red & white)

- Locate the AUDIO OUT L (white) & R (red) outputs on the cable box and the AUDIO IN L & R inputs on your Home Theater receiver.

- Using a two-pronged RCA type audio connector, connect the L & R outputs on the cable box to the L & R inputs on your Home Theater receiver.

Remember L will go to L, and R will go to R.

# OPTIMIZING YOUR HDTV PICTURE

The final step is tailoring your cable box to the capabilities of your HDTV using the On Screen Menu. This allows the cable box to automatically optimize both Standard and High-Definition video, based on your HDTV and personal preferences.

To access the On Screen Menu, power ON your HDTV and power OFF the cable box. Press the MENU button on either your remote control or the cable box front panel to call up the On Screen Display.\* You may use either the cable box front panel or the remote control to navigate the display:



- The arrow on the left indicates the position of the cursor.
- Press the ▲ and ▼ buttons to select the setting you wish to change.
- Press the ► button to select an option for that setting.
- To exit the setting and move to another setting, use the ▲ and ▼ buttons.
- Press the POWER or MENU button to exit the menu and save your settings.

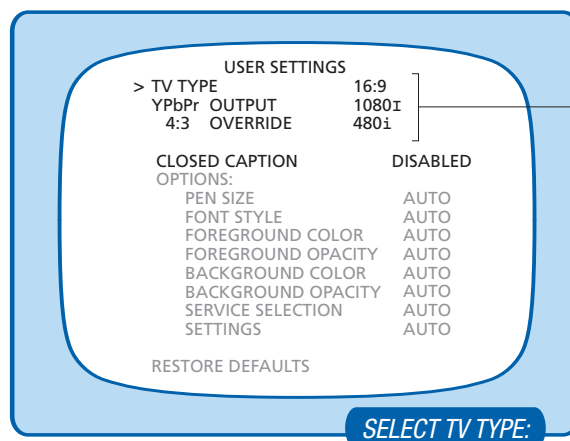

The settings shown in this diagram are for illustrative purposes, and only represent one possible configuration. Please refer to the following sections for more setting options.

## TV TYPE

The first user setting is TV TYPE. Your selection tells the cable box what type of TV you have and how you prefer to watch widescreen programming. Your choices are 16:9, 4:3 Letterbox, or 4:3 Pan Scan.

- Choose 16:9 if you have a widescreen HDTV.
- Choose 4:3 Letterbox if you have a standard TV and you prefer to watch widescreen programming in its original aspect ratio.
- Choose 4:3 Pan Scan if you have a standard screen TV and you prefer that widescreen programming is cropped to fill your screen. Think of this last choice as watching a theater-style movie that has been reformatted to fit your standard screen TV.

## Y Pb Pr OUTPUT

Next, use the down arrow to select Y Pb Pr OUTPUT. This setting indicates the picture resolution you prefer when watching High-Definition programming. The choices, listed in order of highest to lowest picture resolution, are 1080i, 720p, 480p, and 480i. Your selection will depend on which format(s) your HDTV supports. To maximize your high-definition viewing experience, refer to your television set owner's manual, and use the right arrow button to choose the setting that indicates the highest picture resolution that your television will support.

## 4:3 OVERRIDE

Finally, use the down button arrow to select 4:3 OVERRIDE. By selecting 480i or 480p you are telling the cable box to send Standard Definition programming to your TV in its original broadcast format. Select OFF and the cable box will default to the resolution selected in the Y Pb Pr OUTPUT setting above. To exit and save changes press the POWER or MENU button.

For more details on configuring your cable box output settings, including setting Closed Caption preferences, see the Motorola cable box User Guide or visit [www.motorola.com/Broadband](http://www.motorola.com/Broadband).

\* If the On Screen Menu does not appear on your HDTV screen, your TV may not support the default, standard definition setting (480i). Use the cable box front panel LED to view and change your settings.

# TROUBLESHOOTING

**Before calling your cable company, review this troubleshooting guide. This information can help you quickly solve the problem.**

<b>PROBLEM</b>	<b>CAUSE</b>	<b>POSSIBLE SOLUTION</b>
<b>No sound</b>	Accidentally pressed MUTE on the remote control. The receiver is tuned to the wrong entertainment component. You are watching TV using your VCR, and your VCR is off.	Press MUTE on the remote control to restore the volume level. Check that the receiver is set to the proper input source. Turn your VCR on.
<b>No picture</b>	Cable signal may not be reaching your home.	Check to be sure that all cables are connected properly and that your TV is tuned to cable channel 3 or 4, if using the TO TV-VCR connections. Hand-tighten the cable connections if necessary. Check that your component connection cables are not crossed. Y goes to Y, Pb to Pb and Pr to Pr. If connected through the baseband RCA video connection, make sure the cables are connected properly. If you are watching TV using your VCR, be sure your VCR is on, or set to bypass. Ensure that the proper video display format for your TV has been selected.
<b>No Guide or wrong Guide</b>	The DCT is not correctly connected to the cable system.	Check that your cable is connected to the DCT set-top first. NOT looped through the VCR.
<b>Picture or sound is noisy on one channel</b>	Coaxial cable is disconnected or loose. Cable operator is experiencing system difficulties.	Reconnect the cable and hand-tighten if loose. Call your cable operator.
<b>Sound from only one stereo speaker</b>	Cable connections are disconnected or loose.	Hand-tighten or reconnect the cables properly. Ensure that wires are not frayed and plugs are not bent or broken.
<b>No power</b>	Power cord is disconnected.	Reconnect the power cord. Ensure that the cable box is plugged into an outlet that is always live.
<b>Remote control does not work</b>	Remote isn't set in cable TV mode. Obstruction between remote and cable terminal.  Dead batteries.	Press CABLE on the remote control. Ensure that nothing is on the cable box or blocking a clear line of sight between it and the remote control. Change the batteries in your remote control according to the instructions in the section, "Installing Batteries."
<b>Poor audio quality</b>	Audio levels on external devices not set relative to cable box volume level.	For best audio quality, use the remote control to set the cable box to approximately 3/4 of maximum volume level and then adjust the audio levels on the external devices.

**If your problem still exists, please contact your MSO at 1.800.XXX.XXXX.**



**MOTOROLA**  
*intelligence everywhere™*

MOTOROLA and the Stylized M Logo are registered in the US Patent & Trademark Office. All other product or service names are the property of their respective owners. Features and functions subject to change without notice. All rights reserved. Printed in the U.S.A. © Motorola, Inc. 2004.

3/04

**MSO LOGO**

FPO - MSO and the Stylized M Logo are registered in the US Patent & Trademark Office. All other product or service names are the property of their respective owners. Features and functions subject to change without notice. All rights reserved. Printed in the U.S.A. © Motorola, Inc. 2004.

## Free Manuals Download Website

<http://myh66.com>

<http://usermanuals.us>

<http://www.somanuals.com>

<http://www.4manuals.cc>

<http://www.manual-lib.com>

<http://www.404manual.com>

<http://www.luxmanual.com>

<http://aubethermostatmanual.com>

Golf course search by state

<http://golfingnear.com>

Email search by domain

<http://emailbydomain.com>

Auto manuals search

<http://auto.somanuals.com>

TV manuals search

<http://tv.somanuals.com>