

SSE™ 5000
UHF Range 2
(450–488 MHz)

Portable Radio Service Manual



MOTOROLA
intelligence everywhere™





MOTOROLA
intelligence everywhere™

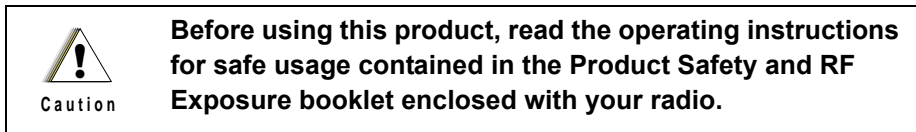
SSE™ 5000
UHF Range 2 (450–488 MHz)
Portable Radio
Service Manual

Foreword

This manual includes all the information necessary to maintain peak product performance and maximum working time of the SSE 5000 portable radio, using Level 1, 2, and 3 service procedures. (For a description of the different levels of service, see [Section 3.1: "Levels of Service" on page 3-1.](#)) Therefore, the manual contains sections on radio specifications for UHF Range 2 (450–488 MHz), a general description of the SSE 5000 radio, radio alignment procedures, test equipment, service aids, general maintenance recommendations, procedures for assembly and disassembly, schematics, board overlays, parts lists, and service procedures down to the component level.

For information on user operation of the radio, refer to the applicable publications available separately (see ["Related Publications" on page vii](#)).

Product Safety and RF Exposure Compliance



ATTENTION!

This radio is restricted to occupational use only to satisfy FCC RF energy exposure requirements. Before using this product, read the RF energy awareness information and operating instructions in the Product Safety and RF Exposure booklet enclosed with your radio (Motorola Publication part number 6881095C98) to ensure compliance with RF energy exposure limits.

Manual Revisions

Changes which occur after this manual is printed are described in FMRs (Florida Manual Revisions). These FMRs provide complete replacement pages for all added, changed, and deleted items. To obtain FMRs, contact the Radio Products Services Division (refer to [Appendix B: "Replacement Parts Ordering"](#)).

Computer Software Copyrights

The Motorola products described in this manual may include copyrighted Motorola computer programs stored in semiconductor memories or other media. Laws in the United States and other countries preserve for Motorola certain exclusive rights for copyrighted computer programs, including, but not limited to, the exclusive right to copy or reproduce in any form the copyrighted computer program. Accordingly, any copyrighted Motorola computer programs contained in the Motorola products described in this manual may not be copied, reproduced, modified, reverse-engineered, or distributed in any manner without the express written permission of Motorola. Furthermore, the purchase of Motorola products shall not be deemed to grant either directly or by implication, estoppel, or otherwise, any license under the copyrights, patents or patent applications of Motorola, except for the normal non-exclusive license to use that arises by operation of law in the sale of a product.

Document Copyrights

No duplication or distribution of this document or any portion thereof shall take place without the express written permission of Motorola. No part of this manual may be reproduced, distributed, or transmitted in any form or by any means, electronic or mechanical, for any purpose without the express written permission of Motorola.

Disclaimer

The information in this document is carefully examined, and is believed to be entirely reliable. However, no responsibility is assumed for inaccuracies. Furthermore, Motorola reserves the right to make changes to any products herein to improve readability, function, or design. Motorola does not assume any liability arising out of the applications or use of any product or circuit described herein; nor does it cover any license under its patent rights nor the rights of others.

Trademarks

MOTOROLA, the Stylized M logo, and FLASHport are registered in the US Patent & Trademark Office. All other products or service names are the property of their respective owners.

© Motorola, Inc. 2005.

Table of Contents

Foreword	ii
Product Safety and RF Exposure Compliance	ii
Manual Revisions	ii
Computer Software Copyrights	ii
Document Copyrights	ii
Disclaimer.....	ii
Trademarks	ii
Commercial Warranty	xi
Special Note on NYPD Warranty Agreement.....	xi
Limited Warranty	xi
MOTOROLA COMMUNICATION PRODUCTS.....	xi
I. What This Warranty Covers And For How Long	xi
II. General Provisions	xii
III. State Law Rights	xii
IV. How To Get Warranty Service	xii
V. What This Warranty Does Not Cover.....	xii
VI. Patent And Software Provisions	xiii
VII. Governing Law.....	xiii
Chapter 1 Radio Description	1-1
1.1 Physical Features of the Radio.....	1-1
1.2 FLASHport®.....	1-1
1.3 Portable Radio Model Numbering System.....	1-2
1.4 SSE 5000 UHF Range 2 (450–488 MHz) Model Chart	1-3
1.5 Specifications for UHF Range 2 (450–488 MHz) Radios	1-4
1.6 Notations Used in This Manual.....	1-5
Chapter 2 Theory of Operation	2-1
2.1 Major Assemblies	2-1
2.2 Mode of Operation	2-2
2.2.1 Receiving	2-2
2.2.2 Transmitting	2-3
2.3 Power Distribution.....	2-4
2.3.1 DC Power Routing—Transceiver Board	2-5
2.3.2 DC Power Routing—VOCON Board.....	2-5
2.4 Transceiver Board	2-7
2.4.1 Interconnections	2-7
2.4.1.1 Battery Connector J3	2-7
2.4.1.2 VOCON Connector P1.....	2-7
2.4.1.3 Antenna Ports	2-8
2.4.1.4 Serial EEPROM	2-8
2.4.1.5 Power Conditioning Components	2-9

2.4.2	Receiver	2-9
2.4.2.1	Receiver Front-End	2-9
2.4.2.2	Receiver Back-End	2-10
2.4.3	Transmitter	2-11
2.4.3.1	Power Distribution	2-12
2.4.3.2	Driver Amplifier	2-12
2.4.3.3	Power Amplifier Transistor Q107	2-12
2.4.3.4	Directional Coupler	2-13
2.4.3.5	Antenna Switch	2-13
2.4.3.6	Harmonic Filter	2-13
2.4.3.7	RF Detector D101	2-14
2.4.3.8	Power-Control IC (PCIC) U104	2-14
2.4.4	Frequency Generation Unit (FGU)	2-16
2.4.4.1	Reference Oscillator Y200	2-16
2.4.4.2	Fractional-N Frequency Synthesizer (FracN) IC U202	2-16
2.4.4.3	Loop Filter	2-17
2.4.4.4	VCO Buffer IC (VCOBIC)	2-17
2.5	VOCON Board	2-17
2.5.1	Interconnections	2-18
2.5.1.1	Transceiver Board Connector P201	2-18
2.5.1.2	Universal Flex Connector J102	2-18
2.5.1.3	Internal Speaker and Microphone Flex Connector M102	2-19
2.5.1.4	Control Top Flex Connector J707	2-19
2.5.1.5	Encryption Module Connector J701	2-19
2.5.1.6	Display Module Connector J301	2-19
2.5.2	Functional Blocks	2-19
2.5.2.1	Controller and Memory	2-19
2.5.2.2	Audio and Power	2-23
2.5.2.3	Interface Support	2-26
2.5.3	Display Module	2-31
2.5.4	Controls and Control Top Flex	2-31
2.5.5	VOCON Audio Paths	2-32
2.5.5.1	Transmit Audio Path	2-32
2.5.5.2	Receive Audio Path	2-33
2.5.6	Radio Power-Up/Power-Down Sequence	2-34

Chapter 3 Test Equipment and Service Aids 3-1

3.1	Levels of Service	3-1
3.2	Test Equipment	3-1
3.3	Service Aids	3-3
3.4	Field Programming	3-6

Chapter 4 Performance Checks 4-1

4.1	Test Equipment Setup	4-1
4.2	Radio Test Mode	4-2
4.2.1	Access the Test Mode	4-2
4.2.2	RF Test Mode	4-4
4.2.3	Control Top Test Mode	4-5
4.3	Receiver Performance Checks	4-6
4.4	Transmitter Performance Checks	4-7

Chapter 5	Radio Alignment Procedures.....	5-1
5.1	Radio Alignment Test Setup	5-1
5.2	Reading the Radio	5-2
5.3	Tuner Menu	5-2
5.4	Radio Information	5-2
5.5	Transmitter Alignments.....	5-3
5.5.1	Softpot	5-3
5.5.2	Reference Oscillator Alignment	5-3
5.5.3	Transmit Power Alignment.....	5-4
5.5.4	Transmit Deviation Balance Alignment.....	5-7
5.5.5	Transmit Deviation Limit Alignment	5-8
5.6	Performance Testing	5-9
5.6.1	Transmitter Test Pattern	5-9
5.6.2	Battery Reading Calibration.....	5-9
Chapter 6	Encryption	6-1
6.1	Load an Encryption Key.....	6-1
6.2	Multikey Feature	6-1
Chapter 7	Disassembly/Reassembly Procedures	7-1
7.1	General Maintenance	7-1
7.1.1	Inspection	7-1
7.1.2	Cleaning.....	7-1
7.2	Handling Precautions.....	7-2
7.3	SSE 5000 Exploded View.....	7-3
7.4	Disassembly/Reassembly Procedures for Accessories.....	7-6
7.4.1	Antenna	7-6
7.4.1.1	Attach the Antenna	7-6
7.4.1.2	Remove the Antenna	7-6
7.4.2	Battery	7-6
7.4.2.1	Attach the Battery	7-7
7.4.2.2	Remove the Battery	7-7
7.4.3	Belt Clip	7-7
7.4.3.1	Attach the Belt Clip	7-7
7.4.3.2	Remove the Belt Clip.....	7-8
7.4.4	Carry Case.....	7-9
7.4.5	Universal Connector Dust Cover	7-10
7.4.5.1	Remove the Universal Connector Dust Cover.....	7-10
7.4.5.2	Attach the Universal Connector Dust Cover	7-10
7.5	Disassembly/Reassembly Procedures for Radio Knobs	7-10
7.5.1	Channel Select Knob.....	7-11
7.5.1.1	Remove the Channel Select Knob.....	7-11
7.5.1.2	Install the Channel Select Knob.....	7-11
7.5.2	Volume Knob	7-11
7.5.2.1	Remove the Volume Knob.....	7-11
7.5.2.2	Install the Volume Knob.....	7-12
7.6	Disassembly Procedures for SSE 5000 Radio	7-12
7.6.1	Separate the Chassis and Housing Assemblies.....	7-12
7.6.2	Disassemble the Chassis Assembly	7-12

7.6.3	Disassemble the Control Top.....	7-13
7.6.4	Disassemble the Housing Baseplate	7-14
7.7	Reassembly Procedures for SSE 5000 Radio	7-15
7.7.1	Reassemble the Control Top	7-15
7.7.2	Reassemble the Chassis Assembly.....	7-16
7.7.3	Join the Chassis and Housing Assemblies	7-16
7.7.4	Reassemble the Housing Baseplate.....	7-17
Chapter 8	Troubleshooting.....	8-1
8.1	Voltage Measurement and Signal Tracing.....	8-1
8.2	Standard Bias Table	8-1
8.3	Power-Up Error Codes.....	8-2
8.4	Operational Error Codes	8-3
8.5	Receiver Troubleshooting.....	8-3
8.6	Transmitter Troubleshooting	8-4
8.7	Encryption Troubleshooting	8-4
Chapter 9	Troubleshooting Charts	9-1
9.1	List of Troubleshooting Charts.....	9-1
9.2	Main Troubleshooting Flowchart.....	9-2
9.6	Volume Set Error	9-11
9.7	Channel Select Error.....	9-12
9.8	Button Test.....	9-13
9.9	Top/Side Button Test	9-14
9.10	VCO TX/RX Unlock.....	9-15
9.15	Keyload Failure	9-28
9.16	Secure Hardware Failure	9-29
Chapter 10	Troubleshooting Tables	10-1
10.1	List of Board and IC Signals	10-1
Chapter 11	Troubleshooting Waveforms	11-1
11.1	List of Waveforms	11-1
11.2	13 MHz Clock.....	11-2
11.3	16.8 MHz Buffer Input and Output	11-3
11.4	32.768 kHz Clock Outputs	11-4
11.5	SPI B Data	11-5
11.6	Receive Serial Audio Port (SAP)	11-6
11.7	Receive Baseband Interface Port (RX BBP).....	11-7
11.8	Transmit Baseband Interface Port (TX BBP).....	11-8
Chapter 12	Schematics, Board Layouts, and Parts Lists	12-1
12.1	Transceiver (RF) Board	12-2
12.2	VOCON Board	12-17

12.3	Control Flex	12-33
12.4	Universal Flex	12-35
12.5	UCM.....	12-37

Appendix A AccessoriesA-1

A.1	Antennas.....	A-1
A.2	Batteries.....	A-1
A.3	Carrying Accessories.....	A-1
A.4	Chargers and Charger Accessories.....	A-1
A.5	Dust Cover.....	A-1
A.6	Keyload Accessories	A-2
A.7	Microphones and Microphone Accessories	A-2
A.8	Programming Cables	A-2
A.9	Surveillance Accessories.....	A-2

Appendix B Replacement Parts Ordering.....B-1

B.1	Basic Ordering Information	B-1
B.2	Transceiver Board and VOCON Board Ordering Information.....	B-1
B.3	Motorola Online	B-1
B.4	Mail Orders	B-1
B.5	Telephone Orders.....	B-1
B.6	Fax Orders.....	B-2
B.7	Parts Identification	B-2
B.8	Product Customer Service.....	B-2

Glossary Glossary-1

Index..... Index-1

Related Publications

SSE 5000 Portable Radio User Guide.....	6881094C11
SSE 5000 Portable Radio User Guide (on CD).....	9985086F04
SSE 5000 Product Listing (Factory Mutual Approval)	6881094C14
SSE 5000 Portable Radio Quick Guide	6881094C16
SSE 5000 Interactive End-User Training (on CD)	6881094C17
SSE 5000 Portable Radio Service Manual (on CD)	9985086F05
FLASHport User Guide.....	6881094C35
CPS Installation guide	6881095C44

Notes

List of Figures

Figure 1-1. Physical Features of the SSE 5000 Radio.....	1-1
Figure 2-1. SSE 5000 Overall Block Diagram.....	2-1
Figure 2-2. Receiver Block Diagram.....	2-2
Figure 2-3. Transceiver (UHF Range) Block Diagram (Power and Control Omitted).....	2-3
Figure 2-4. DC Power Distribution—UHF Radios.....	2-4
Figure 2-5. Abacus III (AD9874) Functional Block Diagram.....	2-11
Figure 2-6. Transmitter Block Diagram.....	2-12
Figure 2-7. VOCON Board Block Diagram.....	2-18
Figure 2-8. Dual-Core Processor EIM and Memory Block Diagram.....	2-23
Figure 2-9. Universal Side Connector.....	2-29
Figure 2-10. VOCON Board Connector J102.....	2-30
Figure 2-11. VOCON Transmit Audio Path.....	2-33
Figure 2-12. VOCON Receive Audio Path.....	2-34
Figure 4-1. Performance Checks Test Setup.....	4-1
Figure 5-1. Radio Alignment Test Setup.....	5-1
Figure 5-2. Tuner Software Main Menu.....	5-2
Figure 5-3. Radio Information Screen.....	5-2
Figure 5-4. Typical Softpot Screen.....	5-3
Figure 5-5. Reference Oscillator Alignment Screen.....	5-4
Figure 5-6. Transmit Power Alignment Screen (High Power).....	5-6
Figure 5-7. Transmit Power Alignment Screen (Low Power).....	5-6
Figure 5-8. Transmit Deviation Balance Alignment Screen.....	5-7
Figure 5-9. Transmit Deviation Limit Alignment Screen.....	5-8
Figure 5-10. Transmitter Test Pattern Screen.....	5-9
Figure 5-11. Battery Reading Calibration Screen.....	5-10
Figure 7-1. SSE 5000 Exploded View.....	7-3
Figure 7-2. Attaching/Removing the Antenna.....	7-6
Figure 7-3. Attaching/Removing the Battery.....	7-7
Figure 7-4. Attaching the Belt Clip.....	7-8
Figure 7-5. Removing the Belt Clip.....	7-8
Figure 7-6. Assembling the Carry Case.....	7-9
Figure 7-7. Attaching the Universal Connector Dust Cover.....	7-10
Figure 11-1. 13 MHz Clock Waveform.....	11-2
Figure 11-2. 16.8 MHz Buffer Input and Output Waveforms.....	11-3
Figure 11-3. 32.768 kHz Clock Outputs Waveforms.....	11-4
Figure 11-4. SPI B Data Waveforms.....	11-5
Figure 11-5. Receive Serial Audio Port (SAP) Waveforms.....	11-6
Figure 11-6. Receive Baseband Interface Port (RX BBP) Waveforms.....	11-7
Figure 11-7. Transmit Baseband Interface Port (TX BBP) Waveforms.....	11-8

List of Tables

Table 2-1.	Conventional Batteries	2-4
Table 2-2.	Smart Batteries	2-4
Table 2-3.	Transceiver Voltage Regulators	2-5
Table 2-4.	VOCON Board DC Power Distribution	2-6
Table 2-5.	Battery Connector J3	2-7
Table 2-6.	VOCON Connector P1	2-7
Table 2-7.	Local Oscillator and First IF Frequencies	2-9
Table 2-8.	Power Control IC (U104) Pin Descriptions	2-14
Table 2-9.	Audio PA Status	2-26
Table 2-10.	Pin Assignments for Universal Side Connector	2-30
Table 2-11.	Option Select Functions	2-31
Table 3-1.	Test Equipment	3-1
Table 3-2.	Service Aids	3-3
Table 4-1.	Initial Equipment Control Settings	4-2
Table 4-2.	Test-Mode Displays	4-3
Table 4-3.	Test Frequencies (MHz)	4-4
Table 4-4.	Test Environments	4-4
Table 4-5.	Receiver Performance Checks	4-6
Table 4-6.	Transmitter Performance Checks	4-7
Table 5-1.	Reference Oscillator Alignment	5-4
Table 5-2.	Transmit Power Settings	5-5
Table 7-1.	SSE 5000 Exploded View Parts List	7-4
Table 7-2.	Tools Used for Disassembly/Reassembly	7-10
Table 8-1.	Standard Operating Bias	8-1
Table 8-2.	Power-Up Error Code Displays	8-2
Table 8-3.	Operational Error Code Displays	8-3
Table 8-4.	Receiver Troubleshooting Chart	8-3
Table 8-5.	Transmitter Troubleshooting Chart	8-4
Table 8-6.	Encryption Troubleshooting Chart	8-4
Table 9-1.	Troubleshooting Charts List	9-1
Table 10-1.	List of Tables of Board and IC Signals	10-1
Table 10-2.	J102 VOCON Board to Universal Flex	10-2
Table 10-3.	J707 VOCON Board to Controls Flex Assembly	10-2
Table 10-4.	J701 VOCON Board to Encryption Module	10-3
Table 10-5.	U402 FLASH Pinouts	10-4
Table 10-6.	U403 SRAM Pinouts	10-6
Table 10-7.	U401 MCU/DSP IC Pinouts	10-8
Table 10-8.	U301 Digital-Support IC Pinouts	10-17
Table 10-9.	U501 GCAP II IC Pinouts	10-19
Table 11-1.	List of Waveforms	11-1
Table 12-1.	List of Transceiver Schematics, Board Layouts and Parts Lists	12-1
Table 12-2.	List of VOCON Schematics, Board Layouts and Parts Lists	12-1
Table 12-3.	List of Control Flex Schematics and Board Layouts	12-1
Table 12-4.	List of Universal Flex Schematics and Board Layouts	12-1
Table 12-5.	List of UCM Schematics and Board Layouts	12-1

Commercial Warranty

Special Note on NYPD Warranty Agreement

The three-year warranty on the NYPD SSE 5000 portable radio units represents the combination of the standard one-year product warranty (detailed in this section) and the two-year Motorola Express Service Plus (ESP) option. ESP is an extended service coverage plan, which provides for the repair of this product for an additional period of two years beyond the expiration date of the standard warranty. For more information about ESP, contact the Motorola Radio Support Center at 2200 Galvin Drive, Elgin IL 60123, (800) 422-4210 (U.S. and Canada) / (847) 538-8023 (international).

Limited Warranty

MOTOROLA COMMUNICATION PRODUCTS

I. What This Warranty Covers And For How Long

MOTOROLA INC. ("MOTOROLA") warrants the MOTOROLA manufactured Communication Products listed below ("Product") against defects in material and workmanship under normal use and service for a period of time from the date of purchase as scheduled below:

SSE 5000 Portable Units	Three (3) Years
Product Accessories	One (1) Year

Motorola, at its option, will at no charge either repair the Product (with new or reconditioned parts), replace it (with a new or reconditioned Product), or refund the purchase price of the Product during the warranty period provided it is returned in accordance with the terms of this warranty. Replaced parts or boards are warranted for the balance of the original applicable warranty period. All replaced parts of Product shall become the property of MOTOROLA.

This express limited warranty is extended by MOTOROLA to the original end user purchaser only and is not assignable or transferable to any other party. This is the complete warranty for the Product manufactured by MOTOROLA. MOTOROLA assumes no obligations or liability for additions or modifications to this warranty unless made in writing and signed by an officer of MOTOROLA. Unless made in a separate agreement between MOTOROLA and the original end user purchaser, MOTOROLA does not warrant the installation, maintenance or service of the Product.

MOTOROLA cannot be responsible in any way for any ancillary equipment not furnished by MOTOROLA which is attached to or used in connection with the Product, or for operation of the Product with any ancillary equipment, and all such equipment is expressly excluded from this warranty. Because each system which may use the Product is unique, MOTOROLA disclaims liability for range, coverage, or operation of the system as a whole under this warranty.

II. General Provisions

This warranty sets forth the full extent of MOTOROLA'S responsibilities regarding the Product. Repair, replacement or refund of the purchase price, at MOTOROLA's option, is the exclusive remedy. THIS WARRANTY IS GIVEN IN LIEU OF ALL OTHER EXPRESS WARRANTIES. IMPLIED WARRANTIES, INCLUDING WITHOUT LIMITATION, IMPLIED WARRANTIES OF MERCHANTABILITY AND FITNESS FOR A PARTICULAR PURPOSE, ARE LIMITED TO THE DURATION OF THIS LIMITED WARRANTY. IN NO EVENT SHALL MOTOROLA BE LIABLE FOR DAMAGES IN EXCESS OF THE PURCHASE PRICE OF THE PRODUCT, FOR ANY LOSS OF USE, LOSS OF TIME, INCONVENIENCE, COMMERCIAL LOSS, LOST PROFITS OR SAVINGS OR OTHER INCIDENTAL, SPECIAL OR CONSEQUENTIAL DAMAGES ARISING OUT OF THE USE OR INABILITY TO USE SUCH PRODUCT, TO THE FULL EXTENT SUCH MAY BE DISCLAIMED BY LAW.

III. State Law Rights

SOME STATES DO NOT ALLOW THE EXCLUSION OR LIMITATION OF INCIDENTAL OR CONSEQUENTIAL DAMAGES OR LIMITATION ON HOW LONG AN IMPLIED WARRANTY LASTS, SO THE ABOVE LIMITATION OR EXCLUSIONS MAY NOT APPLY.

This warranty gives specific legal rights, and there may be other rights which may vary from state to state.

IV. How To Get Warranty Service

You must provide proof of purchase (bearing the date of purchase and Product item serial number) in order to receive warranty service and, also, deliver or send the Product item, transportation and insurance prepaid, to an authorized warranty service location. Warranty service will be provided by Motorola through one of its authorized warranty service locations. If you first contact the company which sold you the Product, it can facilitate your obtaining warranty service. You can also call Motorola at 1-888-567-7347 US/Canada.

V. What This Warranty Does Not Cover

- A. Defects or damage resulting from use of the Product in other than its normal and customary manner.
- B. Defects or damage from misuse, accident, water, or neglect.
- C. Defects or damage from improper testing, operation, maintenance, installation, alteration, modification, or adjustment.
- D. Breakage or damage to antennas unless caused directly by defects in material workmanship.
- E. A Product subjected to unauthorized Product modifications, disassemblies or repairs (including, without limitation, the addition to the Product of non-Motorola supplied equipment) which adversely affect performance of the Product or interfere with Motorola's normal warranty inspection and testing of the Product to verify any warranty claim.
- F. Product which has had the serial number removed or made illegible.
- G. Rechargeable batteries if:
 - any of the seals on the battery enclosure or cells are broken or show evidence of tampering.
 - the damage or defect is caused by charging or using the battery in equipment or service other than the Product for which it is specified.
- H. Freight costs to the repair depot.

- I. A Product which, due to illegal or unauthorized alteration of the software/firmware in the Product, does not function in accordance with MOTOROLA's published specifications or the FCC type acceptance labeling in effect for the Product at the time the Product was initially distributed from MOTOROLA.
- J. Scratches or other cosmetic damage to Product surfaces that does not affect the operation of the Product.
- K. Normal and customary wear and tear.

VI. Patent And Software Provisions

MOTOROLA will defend, at its own expense, any suit brought against the end user purchaser to the extent that it is based on a claim that the Product or parts infringe a United States patent, and MOTOROLA will pay those costs and damages finally awarded against the end user purchaser in any such suit which are attributable to any such claim, but such defense and payments are conditioned on the following:

- A. that MOTOROLA will be notified promptly in writing by such purchaser of any notice of such claim;
- B. that MOTOROLA will have sole control of the defense of such suit and all negotiations for its settlement or compromise; and
- C. should the Product or parts become, or in MOTOROLA's opinion be likely to become, the subject of a claim of infringement of a United States patent, that such purchaser will permit MOTOROLA, at its option and expense, either to procure for such purchaser the right to continue using the Product or parts or to replace or modify the same so that it becomes noninfringing or to grant such purchaser a credit for the Product or parts as depreciated and accept its return. The depreciation will be an equal amount per year over the lifetime of the Product or parts as established by MOTOROLA.

MOTOROLA will have no liability with respect to any claim of patent infringement which is based upon the combination of the Product or parts furnished hereunder with software, apparatus or devices not furnished by MOTOROLA, nor will MOTOROLA have any liability for the use of ancillary equipment or software not furnished by MOTOROLA which is attached to or used in connection with the Product. The foregoing states the entire liability of MOTOROLA with respect to infringement of patents by the Product or any parts thereof.

Laws in the United States and other countries preserve for MOTOROLA certain exclusive rights for copyrighted MOTOROLA software such as the exclusive rights to reproduce in copies and distribute copies of such Motorola software. MOTOROLA software may be used in only the Product in which the software was originally embodied and such software in such Product may not be replaced, copied, distributed, modified in any way, or used to produce any derivative thereof. No other use including, without limitation, alteration, modification, reproduction, distribution, or reverse engineering of such MOTOROLA software or exercise of rights in such MOTOROLA software is permitted. No license is granted by implication, estoppel or otherwise under MOTOROLA patent rights or copyrights.

VII. Governing Law

This Warranty is governed by the laws of the State of Illinois, USA.

Notes

Chapter 1 Radio Description

1.1 Physical Features of the Radio

Figure 1-1 shows the physical features of the SSE 5000 portable radio.

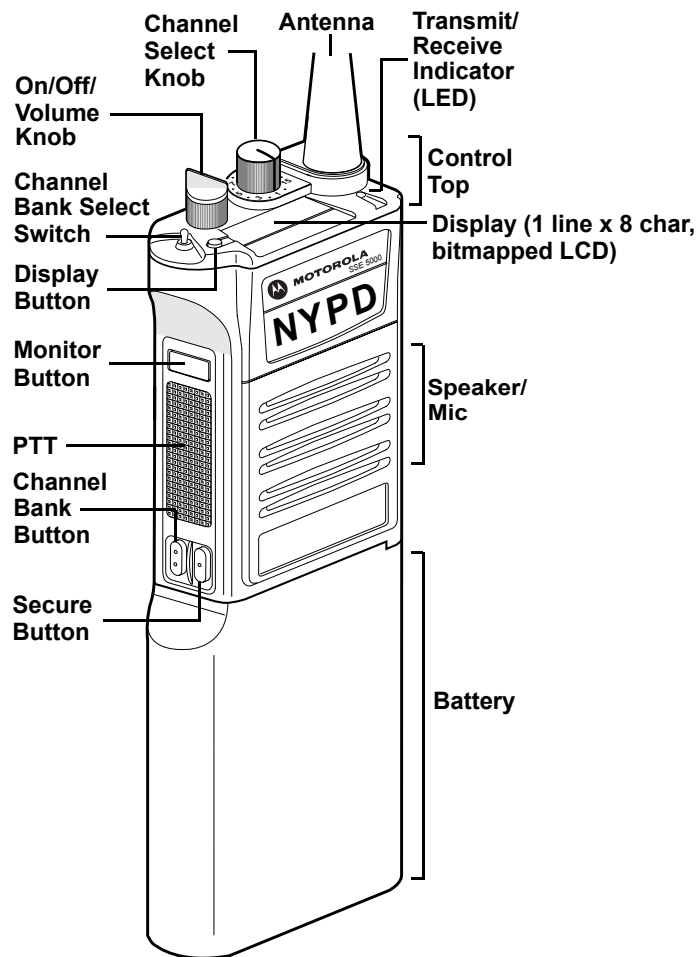


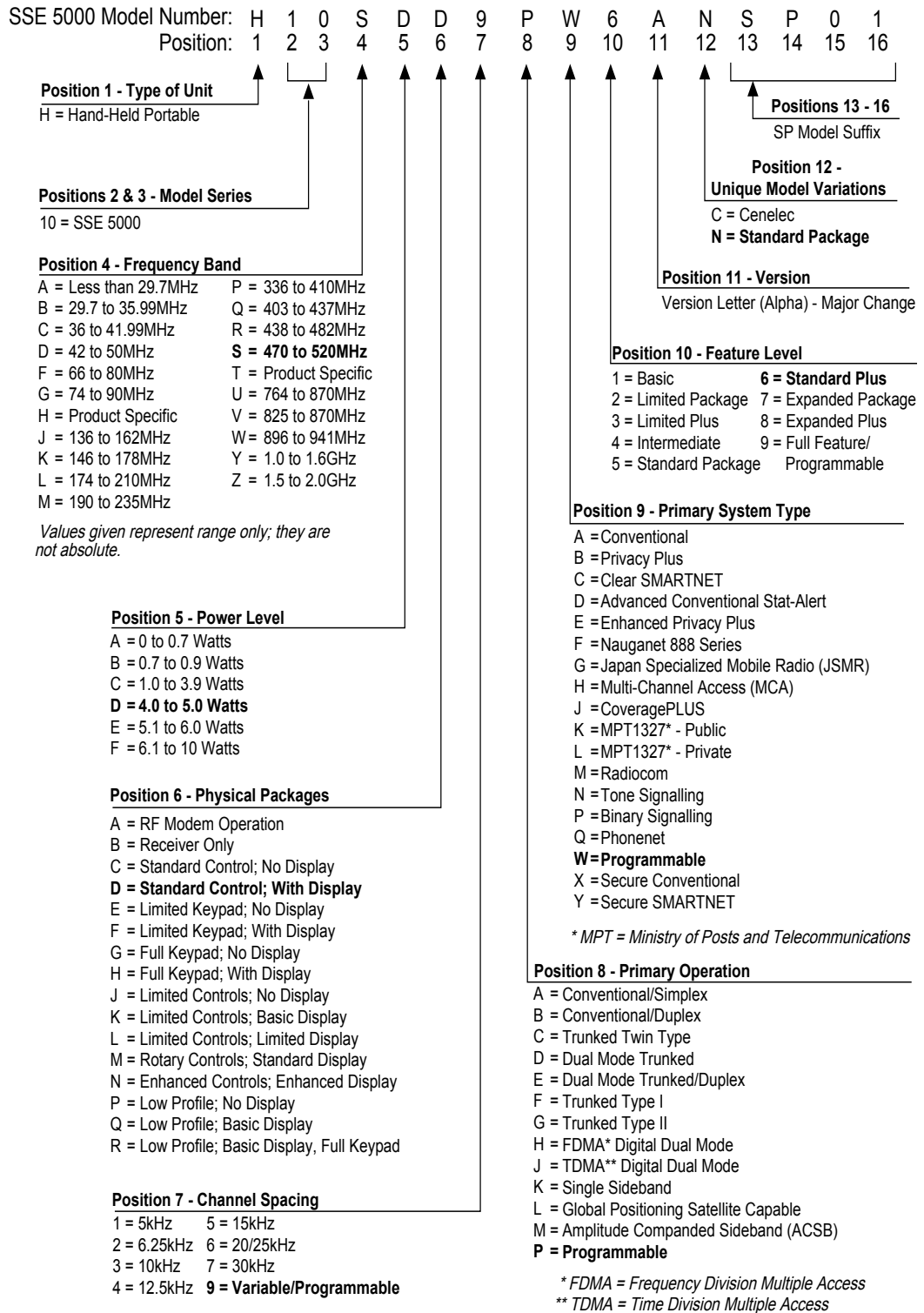
Figure 1-1. Physical Features of the SSE 5000 Radio

The SSE 5000 portable radio operates in the UHF Range 2 (450–488 MHz) frequency band. It can be programmed with up to 96 channels. Earlier versions of the radio, which could be programmed with up to 48 channels, can be upgraded to 96-channel capability via FLASHport[®].

1.2 FLASHport[®]

The SSE 5000 radio utilizes Motorola's FLASHport technology. FLASHport allows you to add software that drives the radio's capabilities, both at the time of purchase and afterwards. Previously, changing a radio's features and capabilities meant significant modifications, or buying a new radio. Now the radio's features and capabilities can be upgraded with FLASHport software, similar to how a computer can be loaded with different software. For information on upgrading the radio's features using FLASHport, see the FLASHport User Guide (Motorola publication part number 6881094C35).

1.3 Portable Radio Model Numbering System



1.4 SSE 5000 UHF Range 2 (450–488 MHz) Model Chart

MODEL NUMBER		DESCRIPTION
H10SDD9PW6AN		UHF Range 2 (450–488 MHz), 2–5 Watts, SSE 5000
ITEM NUMBER		DESCRIPTION
X	—	Antenna, UHF (Refer to Section A.1: "Antennas" on page A-1)
X	—	Battery (Refer to Section A.2: "Batteries" on page A-1)
X	NUE7337_	Board, Transceiver, UHF Range 2 (450–488 MHz)
X	NCN6186_	Board, VOCON *
X	—	Cable, Programming (Refer to Section A.8: "Programming Cables" on page A-2)
X	—	Case, Carrying (Refer to Section A.3: "Carrying Accessories" on page A-1)
X	—	Charger (Refer to Section A.4: "Chargers and Charger Accessories" on page A-1)
X	NTN7061_	Cover, Accessory Connector
X	NNTN4709_	Kit, Belt Clip
X	NNTN4825_	Kit, Chassis, Back
X	NNTN4826_	Kit, Chassis, Front
X	8485687E01	Kit, Control Flex
X	NNTN4468_	Kit, Hardware
X	NNTN4467_	Kit, Housing
X	8485791E01	Kit, Speaker Mic Flex
X	—	Mic Accessories (Refer to Section A.7: "Microphones and Microphone Accessories" on page A-2)
X	NNTN4006_	Module, Encryption, DES, DES-XL, DES-PFB
X	—	Surveillance Accessories (Refer to Section A.9: "Surveillance Accessories" on page A-2)

Notes:

X = Item Included

- * = When ordering a VOCON board, you will be asked to provide the radio's model number, FLASHcode, host code, and DSP code. You can find this information as follows:
- For the radio model number and FLASHcode, place the radio in test mode (see [Section 4.2: "Radio Test Mode" on page 4-2](#)) and view the scrolling displays.
 - For the host code and DSP code, read the radio using the programming cable (RKN4121_ or RKN4122_) and view the information in the CPS.

1.5 Specifications for UHF Range 2 (450–488 MHz) Radios

All specifications are per Telecommunications Industry Association TIA/EIA-603 unless otherwise noted.

GENERAL		RECEIVER	TRANSMITTER
FCC Designation:	AZ489FT4861	Frequency Range:	450–488 MHz
Temperature Range:			
Operating:	–30°C to +60°C	Bandwidth:	38 MHz
Storage:	–40°C to +85°C	Reference Sensitivity (12 dB SINAD) (typical):	0.25 µV
Power Supply:	Nickel-Cadmium Battery (NiCd)	Intermodulation Rejection (typical):	75 dB
Battery Voltage:		Adjacent Channel Rejection (typical):	25/30 kHz 78 dB 12.5 kHz 68 dB
Nominal:	7.5 Vdc	Spurious Response Rejection (typical):	80 dB
Range:	6 to 9 Vdc	Rated Audio Frequency Output Power:	500 mW
Transmit Current Drain (typical)*:		Hum and Noise Ratio (typical):	25 kHz 50 dB 12.5 kHz 43 dB
5W RF Power:	1800 mA	Audio Distortion (typical):	1.0%
2W RF Power:	1100 mA	Channel Spacing:	12.5/25 kHz
Receive Current Drain at Rated Audio (typical)*:	240 mA		
Standby Current Drain (typical)*:	80 mA		
Recommended Battery:			
NiCd:	NTN4595		
or NiCd Smart:	HNN9033		
Optional FM (Factory Mutual) Battery:			
NiCd FM:	NTN4596*		
or NiCd FM (HazMat):	NTN4992*		
or NiCd Smart FM:	HNN9034*		
* FM Intrinsically Safe.			
Dimensions (H x W x D):			
Without Battery (Radio Only):			
H	W	D	
(no antenna) (at cntl top)	(at cntl top)	(at cntl top)	
4.7 in.	2.92 in.	1.37 in.	
119.5 mm	74.2 mm	34.9 mm	
(no antenna) (at bottom)	(at PTT)		
4.7 in.	2.66 in.	1.27 in.	
119.5 mm	67.6 mm	32.2 mm	
With Battery:			
H	W	D	
(no antenna) (at cntl top)	(at cntl top)	(at cntl top)	
8.5 in.	2.92 in.	1.37 in.	
215.9 mm	74.2 mm	34.9 mm	
(no antenna) (at bottom)	(at PTT)		
8.5 in.	2.66 in.	1.27 in.	
215.9 mm	67.6 mm	32.2 mm	
Weight: (w/ Antenna):			
Less Battery:	11.2 oz (316.9 gm)		
With NiCd Smart:	15.9 oz (449.4 gm)		
With NiCd:	13.7 oz (387.8 gm)		

* Test box will add 25 mA.

Specifications subject to change without notice.

1.6 Notations Used in This Manual

Throughout the text in this publication, you will notice the use of note, caution, warning, and danger notations. These notations are used to emphasize that safety hazards exist, and due care must be taken and observed.

NOTE: An operational procedure, practice, or condition that is essential to emphasize.



Caution

CAUTION indicates a potentially hazardous situation which, if not avoided, might result in equipment damage.



WARNING

WARNING indicates a potentially hazardous situation which, if not avoided, could result in death or injury.



DANGER

DANGER indicates an imminently hazardous situation which, if not avoided, will result in death or injury.

Notes

Chapter 2 Theory of Operation

This chapter provides a detailed circuit description of the SSE 5000 transceiver and VOCON boards. When reading the theory of operation, refer to the appropriate schematic and component location diagrams located in the back of this manual. This detailed theory of operation can help isolate the problem to a particular component.

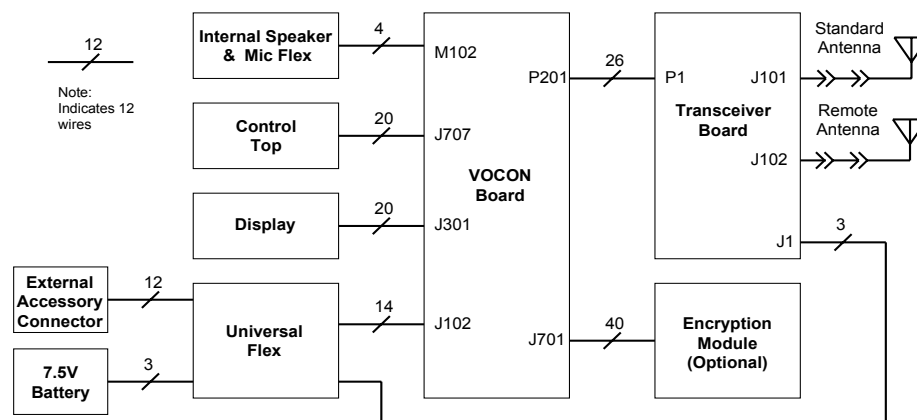
The SSE 5000 radio is a dual-mode (digital/analog), microcontroller-based transceiver incorporating a digital signal processor (DSP). The microcontroller handles the general radio control, monitors status, and processes commands input from the keypad or other user controls. The DSP processes the typical analog signals, and generates the standard signaling digitally to provide compatibility with existing analog systems. In addition, the DSP provides digital modulation techniques, utilizing voice encoding techniques with error correction schemes. This provides the user with enhanced range and audio quality, all in a reduced bandwidth channel requirement. It allows embedded signaling, which can mix system information and data with digital voice to support a multitude of system features.

The SSE 5000 radio operates within the UHF range (450 to 488 MHz).

2.1 Major Assemblies

The SSE 5000 radio includes the following major assemblies (see Figure 2-1):

- **VOCON Board** — contains a dual-core processor which includes both the microcontroller unit (MCU) and a digital signal processor (DSP) core, the processor's memory devices, an audio and power supply support integrated circuit (IC), a digital-support IC, and the audio power amplifier.
- **Transceiver (XCVR) Board** — contains all transmit, receive, and frequency generation circuitry, including the digital receiver back-end IC and the reference oscillator.
- **Controls/Universal Flex** — contains on/off/volume switch, channel select switch, push-to-talk (PTT) switch, monitor button, several function-selectable switches, universal connector, speaker, and microphone.
- **Display** — 112 pixels x 32 pixels bit-mapped, liquid-crystal display (LCD).



MAEPF-27277-B

Figure 2-1. SSE 5000 Overall Block Diagram

2.2 Mode of Operation

This section provides an overview of the radio's receive and transmit operation in the analog mode.

2.2.1 Receiving

When the radio is *receiving* (see Figure 2-2), the signal travels from the antenna connector to the transceiver board, passing through the antenna switch and the receiver front-end. The signal is then filtered, amplified, and mixed with the first local-oscillator signal, generated by the voltage-controlled oscillator (VCO).

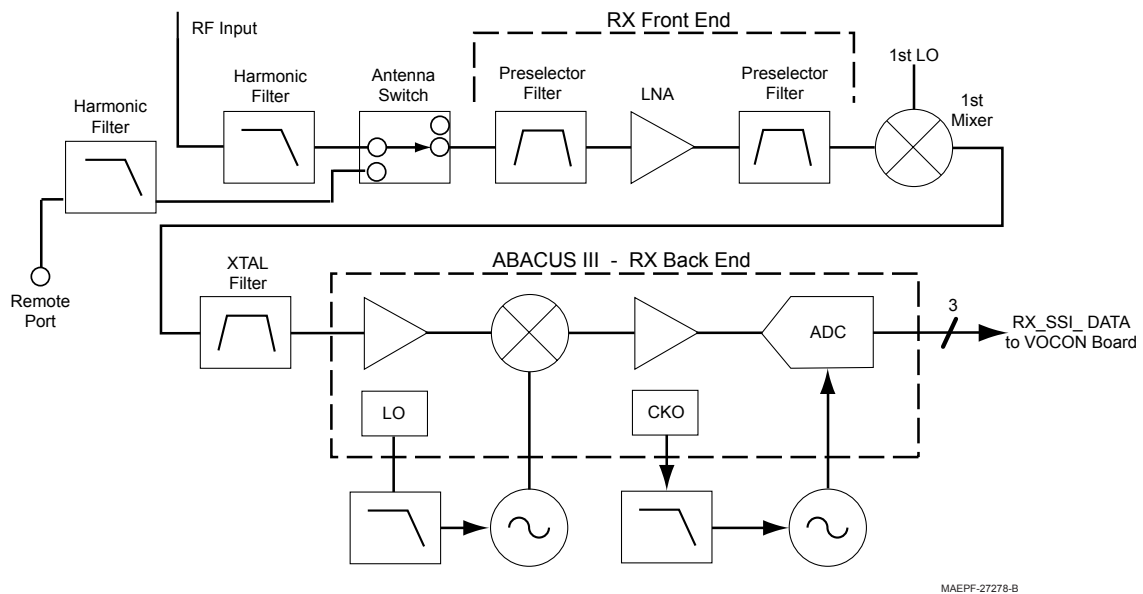


Figure 2-2. Receiver Block Diagram

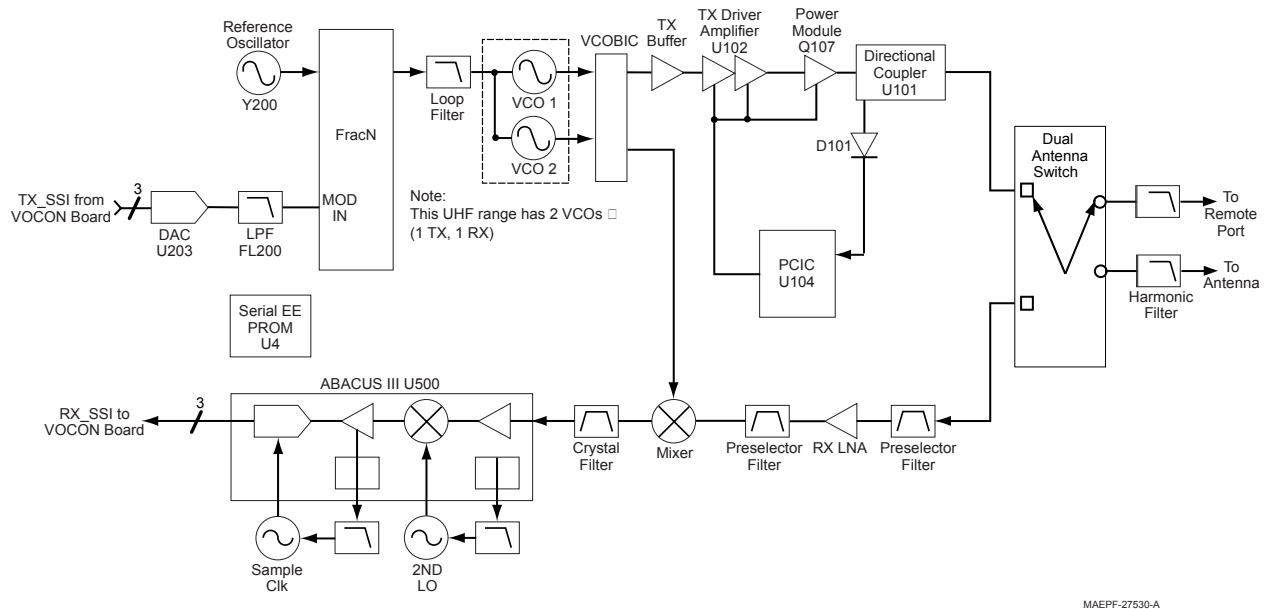
The resulting intermediate frequency (IF) signal is fed to the IF circuitry, where it is again filtered and passed to the Abacus III digital back-end IC. In the digital back-end IC, the IF signal is mixed with the second local oscillator to create the second IF at 2.25 MHz. In the back-end IC, a bandpass, sigma-delta, analog-to-digital converter then decodes the second IF signal, and outputs, on the radio's serial synchronous interface (SSI) bus, digital audio to the VOCON board.

On the VOCON board, the dual-core processor's digital-signal processor (DSP) digitally filters the PCM audio. The DSP decodes the information in the signal and identifies the appropriate destination for it.

- For a voice signal, the DSP will route the digital voice data to the CODEC inside the audio and power supply support IC, for conversion to an analog signal. The CODEC will then present the signal to the receive audio pre-amplifier, then to the audio power amplifier, which drives the speaker.
- For signaling information, the DSP will decode the message and pass it internally to the microcontrol unit of the dual-core processor.

2.2.2 Transmitting

When the radio is *transmitting*, microphone audio is passed through gain stages to the CODEC, where the signal is digitized (see [Figure 2-3](#)). The CODEC passes digital data to the DSP, where pre-emphasis and low-pass (splatter) filtering are done. The DSP passes this signal to a digital/analog converter (DAC), where it is reconverted into an analog signal and scaled for application to the voltage-controlled oscillator as a modulation signal.



MAEPF-27530-A

Figure 2-3. Transceiver (UHF Range) Block Diagram (Power and Control Omitted)

Transmitted signaling information is applied to the DSP from the microcontrol unit, where it is coded, and passed to the DAC, which handles it the same as a voice signal. The DAC output connects to the synthesizer modulation input. A modulated carrier is provided to the transmitter power amplifier, which transmits the signal under dynamic power control.

2.3 Power Distribution

This section provides a detailed circuit description of the power distribution of the SSE 5000 radio.

In the SSE 5000 radio, power (B+) is distributed to two boards: the transceiver (RF) board and the VOCON board (see Figure 2-4). In the case of a secure radio, B+ is also supplied to the encryption module.

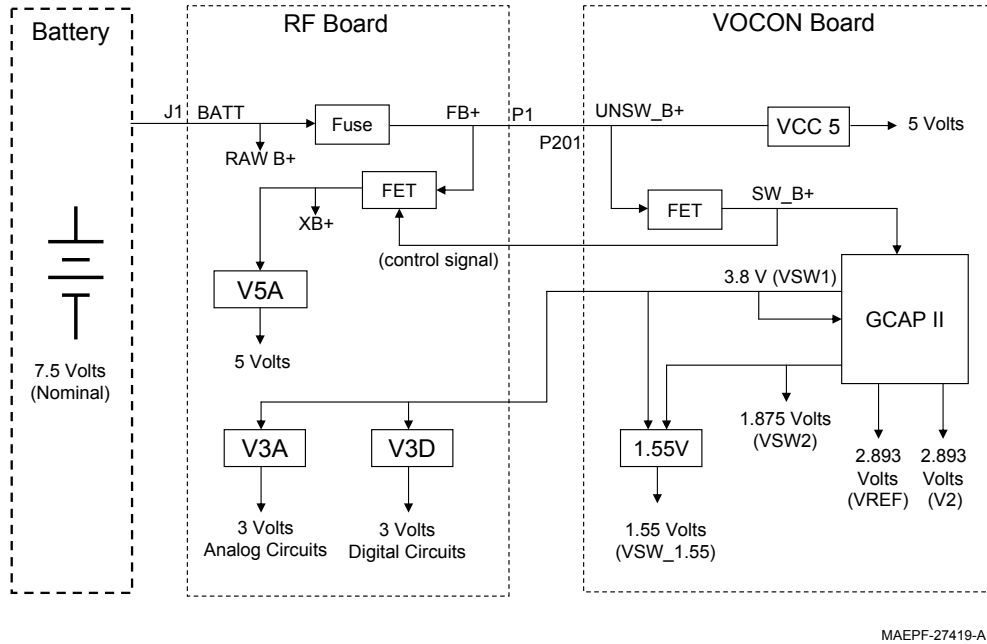


Figure 2-4. DC Power Distribution—UHF Radios

Power for the radio is provided through a battery supplying a nominal 7.5 Vdc directly to the transceiver. The following battery types and capacities are available:

Table 2-1. Conventional Batteries

Part Number	Description
NTN4595	Premium NiCd (1800 mAh, 7.5 V)
NTN4596	Premium NiCd FM (1800 mAh, 7.5 V)
NTN4992	Premium NiCd FM (1800 mAh, 7.5 V) (HazMat)

Table 2-2. Smart Batteries

Part Number	Description
HNN9033	impres™ NiCd (2000 mAh)
HNN9034	impres™ NiCd FM (2000 mAh)

B+ from the battery is electrically switched to most of the radio, rather than routed through the On/Off/Volume knob. The electrical switching of B+ supports a keep-alive mode. Under software control,

even when the On/Off/Volume knob has been turned to the off position, power remains on until the microcontroller unit (MCU) completes its power-down, at which time the radio is physically powered down.

2.3.1 DC Power Routing—Transceiver Board

Connector J1, the B+ assembly, connects the battery to the transceiver board. Two capacitors provide protection against momentary breaks at the B+ connector due to contact bounce when the radio is dropped.

An RF bead forms a power-line filter for signal RAWB+, which supplies battery voltage to the transmitter PA.

A transistor, controlled by signal SWB+ from the VOCON board, turns on XB+, which supplies the 5-V linear regulator, TX_ALC block and SW_FL.

Fuse F901 and a filter supply fused B-plus to the VOCON board. In turn, the VOCON board supplies VSW1, regulated 3.8 Vdc, from the Global Control Audio and Power (GCAP) switching regulator to the XCVR. A switch, controlled by SWB+, turns on V38 to the XCVR 3-V linear regulators. The XCVR regulated power supplies are summarized in [Table 2-3](#).

Table 2-3. Transceiver Voltage Regulators

IC Name	Output Signal Name	Description
LP2989	V5A	Regulated 5.0 Vdc
LP3985	V3D	Regulated 3.0 Vdc digital
LP3985	V3A	Regulated 3.0 Vdc analog for the RX FE

2.3.2 DC Power Routing—VOCON Board

Raw B+, or unswitched B+, (UNSW_B+) is routed to connector J1 on the transceiver board, and then on to P201 on the VOCON board. Here the UNSW B+ is forwarded to the radio's control top On/Off/Volume knob through connector J707 and a flex circuit, as well as to regulator U505 (VCC5).

The On/Off/Volume knob controls B+SENSE to a BJT switch, which in turn controls a power MOSFET. The MOSFET is a solid-state power switch that provides SW B+ to the VOCON board, the audio PA, the GCAP II IC (via GCAP_B+), and back to the transceiver board.

In the case of a secure radio model, SW B+ and UNSW B+ are also supplied to the encryption module through connector J701.

The BJT switch is also under the control of the MCU via Vref from the GCAP II IC (U501). This allows the MCU to follow an orderly power-down sequence when it senses that B+SENSE is off. This sense is provided through MECH_SW_BAR (inverted B+SENSE).

The digital circuits in the VOCON board are powered from regulators located in the GCAP II IC (U501), an external 5 Vdc regulator (VCC5, U505), and an external 1.55 Vdc regulator (VSW_1.55). The GCAP II IC provides three supplies: VSW1, VSW2, and V2. These regulators are software programmable.

Table 2-4 lists the supply voltages and the circuits that use these voltages.

Table 2-4. VOCON Board DC Power Distribution

Supply Name	Output Voltage	Supply Type	Unprogrammed Output Voltage	Circuits Supplied
UNSW_B+	9 to 6 Vdc 7.5 Vdc nominal	Battery	N/A	VCC5 input Mechanical switch Power switch (FET) Secure module
SW_B+	9 to 6 Vdc 7.5 Vdc nominal	Battery	N/A	VSW1 input (GCAP) Audio power amplifier Side connector SW_B+ to transceiver board GCAP IC Secure module USB circuitry
VCC5	5Vdc	Linear regulator	N/A	Smart battery circuitry Int. / ext. microphone bias Audio preamplifier Digital-support IC Display LEDs
VSW1	3.8 Vdc	Switching regulator software programmable	3.2 Vdc	3-V regulators (RF) VSW2 input V2 input 1.55 V regulator bias
VSW2	1.8 Vdc	Switching regulator software programmable	2.2 Vdc	Dual-core processor's external memory interface FLASH IC SRAM 1.55 V regulator bias
VSW_1.55	1.55 Vdc	Linear regulator	N/A	Dual-core processor core
V2	2.893 Vdc	Switching regulator software programmable	2.775 Vdc	Dual-core processor's I/O ring Digital-support IC EEPOT Display 16.8 MHz buffer

2.4 Transceiver Board

The transceiver (XCVR) board performs the transmitter and receiver functions necessary to translate between voice and data from the VOCON board and the modulated radio-frequency (RF) carrier at the antenna. The transceiver board contains all the radio's RF circuits for the following major components:

- Receiver
- Transmitter
- Frequency Generation Unit (FGU)

2.4.1 Interconnections

This section describes the various interconnections for the transceiver board.

2.4.1.1 Battery Connector J3

Battery connector J3 consists of three gold-plated contacts on the printed circuit board that mate with a B-plus connector assembly. Signal descriptions are in [Table 2-5](#).

Table 2-5. Battery Connector J3

Pin No.	Signal	Description
1	BATT	Battery positive terminal, nominally 7.5 Vdc
2	BSTAT	Battery status, from battery to VOCON
3	BAT_RTN	Battery negative terminal, tied to PCB ground

2.4.1.2 VOCON Connector P1

VOCON connector P1 (located on the XCVR board) consists of 26 gold-plated pads for the 26-pin compression connector, and one plated tool hole (pin 27) used for connector alignment. This is a digital interface carrying DC power, control, and data between the XCVR and VOCON boards. P1 connects through the compression connector to P201 on the VOCON board.

[Table 2-6](#) lists the connector pins, their signals, and functions. SPI refers to the serial peripheral interface, which is the control bus from the microprocessor. SSI is the serial synchronous interface bus for data to and from the DSP. There is a RX SSI bus for demodulated data from the receiver and a TX SSI bus for modulation data to the transmitter.

Table 2-6. VOCON Connector P1

Pin No.	VOCON Signal	XCVR Signal	XCVR I/O	Type	Description
1	UNSW_B+	FUB+	O	dc	Fused B+ to VOCON
2	UNSW_B+	FUB+	O	dc	Fused B+ to VOCON
3	LOCK_DET*	LOCK	O	status	FGU lock detect
4	TX_SSI_DATA	TXTD	O	ssi	TX SSI data
5	SSI_CLK	RXCK	O	ssi	RX SSI clock

Table 2-6. VOCON Connector P1 (Continued)

Pin No.	VOCON Signal	XCVR Signal	XCVR I/O	Type	Description
6	SSI_FSYNC	RXFS	O	ssi	RX SSI frame sync
7	16.8MHz	F168	O	RF	16.8 MHz reference clock
8	SW_B+	SWB+	I	dc	Switch control
9	TX_SSI_FSYNC	TXFS	I	ssi	TX SSI frame sync
10	TX_SSI_CLK	TXCK	I	ssi	TX SSI clock
11	AD4_RF_BD_ID	RF_BD_ID	O	dc	RF board ID
12	RX_SSI_DATA	RXDO	O	ssi	RX SSI data
13	ABACUS3_CS	ABCS	I	ssi	SPI Abacus chip select
14	GND	GND			
15	VSW1	VSW1	I	dc	Regulated 3.8 V
16	SPI_CLK_A	SPCK	I	spi	SPI clock
17	SPI_MISO_A	MISO	O	spi	SPI data out
18	EEPROM_SEL*	EECS	I	spi	SPI EEPROM chip select
19	TX_INHIBIT	TXINH	I	control	TX inhibit control for secure
20	GND	GND			
21	BAT_STATUS	BSTAT	O	dc	Battery status
22	GND	GND			
23	SPI_MOSI_A	MOSI	I/O	spi	SPI data I/O
24	UNI_CS	USEL	I	spi	SPI universal chip select
25	RF_RX_ATNR	RX_ATNR	I	dc	RF RX attenuator
26	POR*	RSTL	I/O	control	asynchronous reset, active low

2.4.1.3 Antenna Ports

Antenna port J101 is a hot launch connector that interfaces to the antenna connector that is part of the control top. This interface provides the launch mechanism for the antenna. Antenna port J102 provides RF to the accessory RF connector on the back of the SSE 5000 radio. This port provides RF energy for tuning purposes, as well as RF for a public safety microphone.

2.4.1.4 Serial EEPROM

The serial, electrostatically erasable, programmable, read-only memory (EEPROM) has the reference designator U4 on the SSE 5000 transceiver board. This IC holds all of the transceiver tuning data. This allows transceivers to be tuned in the factory and installed in the field without retuning.

2.4.1.5 Power Conditioning Components

DC power-conditioning components include zener diodes, capacitors, ferrite beads, a power inductor, and the fuse. Diodes VR1 and VR2 provide over-voltage protection. Ferrite beads (designated E1, E4, E101) and capacitors suppress electromagnetic interference from the transceiver. The power-line filter consisting of L1, C13, and C14 suppresses digital noise from the VOCON board switching power supplies that could degrade the transmitter spectral purity.

Pass transistor Q1 switches the battery voltage to the transceiver when control signal SWB+ or SB+ from the VOCON board is asserted high. This increases the transceiver's immunity to conducted interference that might be present on SWB+ or SB+, such as from switching voltage regulators on the VOCON board.

Ground clip G9 makes contact between the transceiver board ground and the radio chassis. The chassis connection is a necessary electrical reference point to complete the antenna circuit path. Shields SH201 through SH702 and the tool hole appear on the schematic to show their connection to ground.

2.4.2 Receiver

The SSE 5000 transceiver has a dual-conversion superheterodyne receiver. [Figure 2-2](#) illustrates the major receiver components:

- Receiver front-end
- Receiver back-end

2.4.2.1 Receiver Front-End

NOTE: Refer to [Figure 2-2](#) for the receiver block diagram, [Table 2-7](#) for local oscillator (LO) and first IF information, and [Figure 12-2](#) for the receiver front-end schematic.

The receiver front-end tunes to the desired channel and down converts the RF signal to the first intermediate frequency (IF). Channel selection is by way of a tunable local oscillator, RXLO, from the FGU.

Table 2-7. Local Oscillator and First IF Frequencies

	UHF Range 2 (450–488 MHz)
LO Frequency Range	376.65–414.65 MHz
First IF Frequency	73.35 MHz

The receiver front-end consists of a preselector filter, an RF amplifier, a second preselector, mixer, and an IF crystal filter. The SSE 5000 radio also contains a switchable attenuator between the antenna switch and the first preselector filter. The RF amplifier is a discrete RF transistor with associated circuitry. The mixer is a double-balanced, active mixer IC, coupled by transformers. The receiver (RX) local oscillator (LO) is provided by the FGU.

2.4.2.1.1 Preselector Filters

The receiver front-end uses two discrete bandpass filters to achieve its required out-of-band rejection. The first preselector filter precedes the RF amplifier, while the second preselector filter follows the RF amplifier.

2.4.2.1.2 LNA (Low-Noise Amplifier)

The SSE 5000 radio uses a discrete transistor for the low-noise amplifier (Q430). A feedback network between the collector and base improves stability and gain balance across the frequency band. Input and output LC networks match the LNA impedance to 50 ohms.

A diode limiter (D400) protects the amplifier damage by strong input signals.

2.4.2.1.3 Mixer

The mixer (U470) down-converts the received RF to the first intermediate frequency (IF). The IF is 73.35 MHz. Low-side LO injection is used. Transformers are used as baluns to convert signals from single-ended to balanced at pins MI, MIX, LO, and LOX. An output transformer converts the balanced signal at pins MO and MOX to a single-ended output.

2.4.2.1.4 IF Filter

The IF filter (FL400) is a leadless, surface-mount, 3-pole, quartz crystal filter. This narrow bandpass filter gives the radio its adjacent-channel and alternate-channel rejection performance.

Input and output LC networks match the filter impedance to 50 ohms.

2.4.2.2 Receiver Back-End

NOTE: Refer to [Figure 2-2](#) for the receiver block diagram and [Figure 12-3](#) for the receiver back-end schematic.

The receiver back-end, which consists of the Abacus III (AD9874 IF digitizing subsystem) IC and its associated circuitry, processes the down-converted IF signal to produce digital data for final processing by the VOCON DSP.

2.4.2.2.1 Abacus III IC U500

The AD9874 is a general-purpose, IF subsystem that digitizes a low-level 10–300 MHz IF input with a bandwidth up to 270 kHz. The output of the Abacus III IC is SSI data to the VOCON.

The signal chain of the AD9874 consists of a low-noise amplifier, a mixer, a bandpass sigma-delta A/D converter, and a decimation filter with programmable decimation factor. An automatic gain control (AGC) circuit provides the AD9874 with 12 dB of continuous gain adjustment. The high dynamic range and inherent anti-aliasing provided by the bandpass sigma-delta converter allow the AD9874 to cope with blocking signals 80 dB stronger than the desired signal.

Auxiliary blocks include frequency synthesizers for the second LO and sampling clock LO, as well as an SPI port. The second LO uses a discrete external loop filter and VCO. The clock oscillator has an external loop filter and resonator.

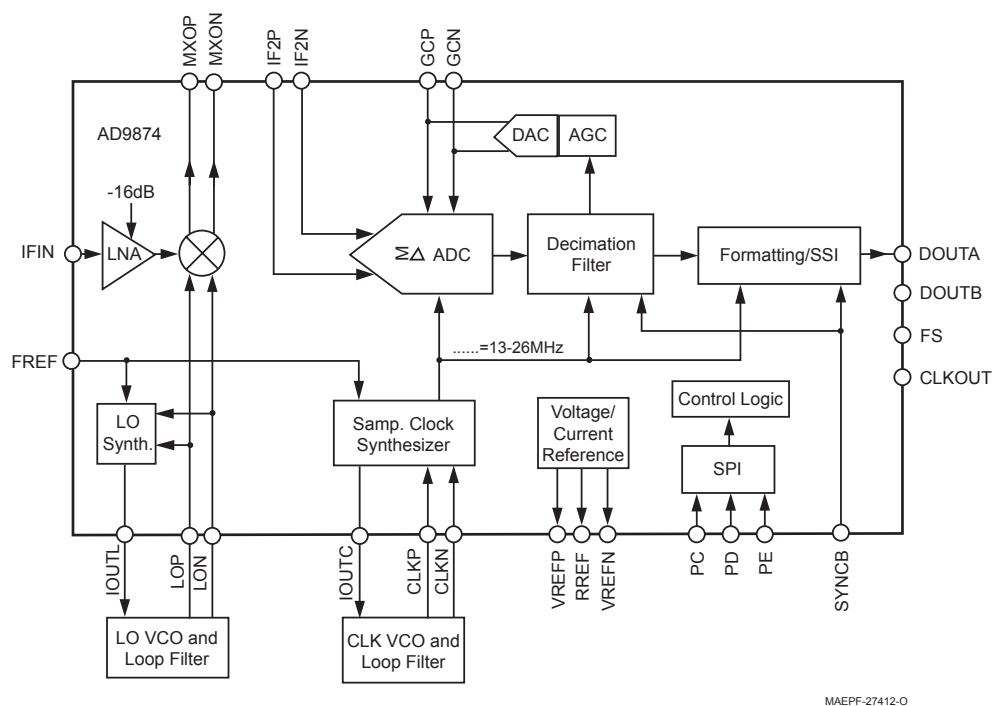


Figure 2-5. Abacus III (AD9874) Functional Block Diagram

Input signal RXIF is 73.35 MHz IF from crystal filter FL400 in the receiver front-end. Components L547 and C542 match the input impedance to 50 ohms. Formatted SSI data is output to the VOCON board on ports FS, DOUTA, and CLKOUT.

2.4.2.2.2 Second Local Oscillator

The second LO is controlled by the Abacus LO synthesizer, which mixes with IFIN to produce a 2.25 MHz final IF. The external VCO consists of Q502 and its bias network and frequency-determining elements. Signal FREF is the 16.8 MHz reference from the FGU. Darlingtion transistor Q501 with C550 and R501 form an active power-line filter.

The second LO frequency is 71.1 MHz by default or 75.6 MHz in special cases as needed to avoid radio self-quieters. The loop filter is composed of R551, C558, C559, R552, and C512.

2.4.2.2.3 Sampling Clock Oscillator

The Abacus sampling clock synthesizer operates at 18 MHz = 8 x 2.25 MHz. The VCO uses an internal transistor and external resonator. The resonator is composed of L503, C535, C929, and D501.

The loop filter is composed of R512, C536, R514, C570, and C571.

2.4.3 Transmitter

NOTE: Refer to [Figure 2-6](#) for the transmitter block diagram and [Figure 12-4](#) for the transmitter schematic.

The transmitter takes modulated RF from the FGU and amplifies it to the radio's rated output power to produce the modulated transmitter carrier at the antenna.

The transmitter consists of an RF driver IC that receives its input signal from the voltage-controlled oscillator (VCO) and a high-power output transistor. Transmitter power is controlled by a power-

control IC (PCIC) that senses the output of a directional coupler and adjusts PA control voltages to maintain a constant power level. The signal passes through a dual antenna switch and harmonic filters to the antenna or to the remote RF port.

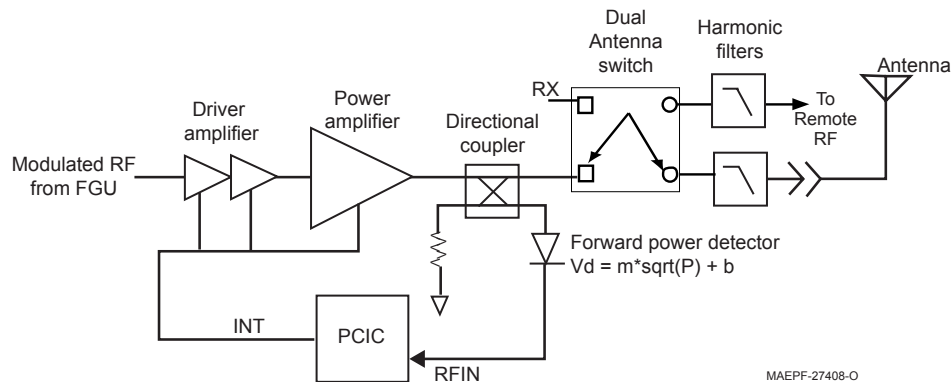


Figure 2-6. Transmitter Block Diagram

2.4.3.1 Power Distribution

To minimize voltage drop to the power amplifiers, net RAWB+ connects to power module Q107 and the second stage of driver amplifier U102 through components having minimal series resistance—ferrite beads and chokes only. During receive, no RF or DC bias is applied, and leakage current through U102 and Q107 is less than 100 microamps.

At the rated transmitter power of 5 Watts, the radio consumes approximately 1800 mA, and at the rated transmitter power of 2 Watts the radio consumes approximately 1100 mA.

2.4.3.2 Driver Amplifier

The driver amplifier IC (U102) contains two LDMOS FET amplifier stages and two internal resistor bias networks. Pin 16 is the RF input. Modulated RF from the FGU, at a level of +3 dBm \pm 2 dB, is coupled through a DC blocking capacitor to the gate of FET-1. An LC interstage matching network connects the first stage output VD1 to the second stage input G2. The RF output from the drain of FET-2 is pin 6 (RFOUT1). Gain control is provided by a voltage applied to pin 1 (VCNTRL). Typical output power is about +27 dBm (500 mW) with VCNTRL at 5.0 V.

L109 and C113 are the interstage matching network. Components L105 and C110 match the output impedance to 50 ohms; capacitor C107 is a DC block.

2.4.3.3 Power Amplifier Transistor Q107

The power amplifier transistor, Q107, is an LDMOS FET housed in a high-power, surface-mount, ring package. To prevent thermal damage, it is essential that the heat sink of the power module be held in place against the radio chassis. The input impedance-matching network uses discrete inductors and capacitors. The low-pass output matching network uses both transmission lines and lumped LCs. Drain bias is applied through E101 and L101. Gain is dynamically controlled by adjusting the gate bias. The gate is insulated from the drain and source so that gate bias current is essentially zero.

The input impedance-matching network is L106, L107, C108, and C109. A transmission-line structure and C137, C111, L110 and C112 form the output-matching network. Gate bias is applied through R105 and L108.

2.4.3.4 Directional Coupler

A directional coupler senses the transmitter forward power as a control signal in the transmitter's automatic level control (ALC) loop. Isolated ports are terminated with external resistors.

The directional coupler is U101, a low-loss, bidirectional coupler.

2.4.3.5 Antenna Switch

The SSE 5000 has two antenna switches: one standard antenna switch and a remote antenna switch.

The standard antenna switch is a quarterwave switch that determines whether the radio is in receive or transmit mode. The standard antenna switch consists of part numbers D701, D702, C706, C704, C701, C707, L702, L703, and R701. When the standard antenna switch is in receive mode, the diodes D701 and D702 are unbiased and radio signals are able to travel to the receive front-end. When the standard antenna switch is in transmit mode, radio signals travel from the transmitter to the selected port and radio signals from the transmitter to the receive front-end are redirected by the large impedance presented by L702 and C704. The receive front-end is also protected from the transmitter because of the combined effect of the radio wave redirection and the short produced by C703 when the standard antenna switch is enabled.

The circuitry that enables the standard antenna switch consists of part numbers L703, C707, and U104. When the radio is in transmit mode, pin 32 (also known as ANO) on U104 provides approximately 6.7 volts to diode D702. This voltage is dropped approximately 1.4 volts, or two diode drops, and applied to R701. R701 sets the current through the antenna switch (approximately 14 mA). L703 and C707 are used as a DC bias network designed to only transmit DC signals.

The remote antenna switch is also a quarterwave switch, but this switch determines which antenna the radio uses for transmit or receive. The remote antenna switch consists of part numbers D602, D601, C724, C725, C726, C727, C728, L701, L704, L711, R703, R704, R705, Q702, and Q703.

When the radio is receiving from the standard antenna, no diodes are forward biased. In order to activate the remote antenna port, the VOCON must supply 2.9 volts (+/- 3%) to pin 19 of the 26-pin connector. Pin 19 is also known as TX_INH. TX_INH going high causes the voltage on the collector of Q703 to become the voltage on the emitter. The voltage on the emitter for this circuit is zero volts. The collector is connected to the gate of Q702, which in turn forces the voltage on the drain of Q702 to become the voltage on the source of Q702. The voltage on the source of Q702 is switched B+, or battery voltage. Switched B+ is dropped approximately 1.4 volts, or two diode drops, and applied to R705. R705 sets the current through the remote port switch (approximately 12 mA).

L701 and C724 are used as a DC bias network designed to only transmit dc signals. When the radio is receiving or transmitting through the remote port, radio signals travel through diode D602. The signals are directed away from the standard antenna by the large impedance presented by L704 and C727. Accidental radiation through the standard antenna is prevented, because of the combined effect of the radio wave redirection and the short produced by C725 when the remote port is enabled.

NOTE: Part numbers C728 and L711 are used to resonate the parasitic capacitance created by diode D602. The parasitic capacitance was creating a degradation in the transmit response through the standard antenna port. Essentially, C728 is a DC block to prevent reverse biasing D602, and L711 resonates with the parasitic capacitance of D602 to create a large impedance.

2.4.3.6 Harmonic Filter

RF from the power amplifier is routed through the coupler (U101), passed through the antenna switch, passed through the remote port switch, and applied to a harmonic filtering network. The SSE 5000 harmonic filters are five-pole elliptical low-pass filters.

The initial design utilizes a cutoff frequency of 750 MHz, even though the actual design cutoff frequency is 488 MHz. The reasoning behind using a significantly higher cutoff frequency is due to the lower frequency response of realized circuits. The design tables used for the filter synthesis can be located in the *Handbook of Filter Synthesis* (Zverev, pp. 218–219), where $\theta = 47.0$. This design was chosen because the attenuation at the stop band was the closest to the desired ratio for the SSE 5000 design.

The remote port harmonic filter consists of parts C709, C710, C711, C712, C713, L706, and L707. The antenna port harmonic filter consists of parts C716, C717, C718, C719, C720, L709, and L710. The filters are optimized for the impedance match seen for their respective ports and terminations.

NOTE: Capacitor C720 was changed to 2pF, because this value improved the radiated response of the radio with the antenna removed. Also, Capacitors C710 and C711 were increased in order to remove a spur located at the (2*LO)-IF frequency point (680.075 MHz), where LO is 450.0625 MHz – 73.35 MHz and IF is 73.35 MHz. Essentially, C710 and C711 decreased the cutoff frequency of the remote port harmonic filter.

2.4.3.7 RF Detector D101

Schottky diode D101 is used as a forward-power detector. Forward-coupled RF from the power amplifier is converted to a DC voltage. Detector output is a positive DC voltage, proportional to the amplitude of the RF signal at the input, and is applied to the ALC input of the PCIC.

2.4.3.8 Power-Control IC (PCIC) U104

The PCIC, U104, contains all of the digital, and most of the analog, circuits needed to control the transmitter power amplifier. Host control is through a 3-wire, smart SPI interface. Pin descriptions are shown in [Table 2-8](#).

Table 2-8. Power Control IC (U104) Pin Descriptions

Pin	Name	Description
1	RFIN	Detector voltage input to ALC
2	T1	Test point
3	CI	External capacitor for integrator time constant
4	INT	Integrator output; control voltage to amplifiers
5	CJ	External capacitor for PA rise and fall times
6, 7	VL, CL	External capacitor for PA rise and fall times
8	GND1	Ground
9	F168	Reference clock input, 2.1 MHz
10, 13	QX, CQX	External capacitor for voltage multiplier
11, 12	Q, CQ	External capacitor for voltage multiplier
14	V10	Voltage multiplier output
15	VG	Internal band-gap reference voltage
16	V45	Regulated 4.5 Vdc output
17	V5EXT	Power supply input for internal voltage regulator

Table 2-8. Power Control IC (U104) Pin Descriptions (Continued)

Pin	Name	Description
18	VAR2	Buffered D/A output
19	VLIM	Test point for internal D/A No.2 voltage
20	VAR1	Buffered D/A output
21	RS	Asynchronous reset input
22	NA	Spare pin
23	RX	RX/TX mode control-bit output
24	VAR3	Buffered D/A output
25	GND2	Ground
26	CLK	SPI clock input
27	BPOS	Power supply input
28	DATA	SPI data input/output
29	CEX	SPI chip select input
30	TEMP	Temperature sensor input
31	RSET	External resistor; used to set the temperature cutback rate
32	ANO	Switched BPOS output

2.4.3.8.1 Power and Control

Since U104 is powered from switched B+, it makes its own regulated 4.5 Vdc to power the internal logic. The supply input is V5EXT at pin 17, and the output is V45 at pin 16. ANO at pin 32 is the control signal to the RX/TX antenna switch control circuit.

2.4.3.8.2 Automatic Level Control (ALC)

In TX mode, the PCIC disables the receiver, turns on the transmitter, and controls the TX power level. The automatic level control (ALC) circuit operates as follows:

The power level is set by programming an internal DAC to a calibrated reference voltage. D/A settings for the power set points were determined during radio tuning and stored in EEPROM. An internal op-amp compares the D/A reference voltage to the detector voltage at pin 1 (RFIN) (TP101) and produces an error signal output. This signal is buffered by another op-amp, configured as a low-pass filter, or integrator, to produce the INT output at pin 4 (TP111).

This INT output supplies voltage to drive the gain control pins of amplifiers U102 and Q107. Resistors R105 and R106 determine the voltage ratio between U102 pin 1 (VCNTRL) and the Q107 gate. Transient response during key-up and key-down is controlled by the power amplifier rise and fall times. External capacitors at pins CI, CJ, and CL, along with internal programmable resistors, determine the ALC time constants.

2.4.3.8.3 Temperature Cut Back

The PCIC contains a temperature cut-back circuit to protect the power amplifier (PA) from thermal damage that might result from incorrect assembly of the radio. External sensor U103 is a linear temperature-to-voltage transducer, placed near the hottest spot in the radio: power module Q107.

The output is a DC voltage at pin 2 (VOUT) proportional to the temperature at pin 3 (GND). VOUT is 750 mV at 25°C and increases by 10 mV/°C. The PCIC temperature cut-back threshold is programmed to correspond to 85 or 90°C. Above this threshold, the ALC gradually cuts back the transmitter until it is fully turned off at 125°C. The slope of cut-back versus temperature is set by external resistor R111. Diode D104 clamps TEMP to a voltage not much less than VG (pin 15), about 1.3 V, to improve the transient response of the cut-back circuit.

2.4.4 Frequency Generation Unit (FGU)

The frequency-generation function is performed by several ICs, two voltage-controlled oscillators (VCOs) (one transmit and one receive), and associated circuitry. The reference oscillator provides a frequency standard to the fractional-N frequency synthesizer (FracN) IC, which controls the VCOs and VCO buffer IC (VCOBIC). The VCOBIC amplifies the VCO signal to the correct level for the next stage.

NOTE: Refer to [Figure 12-5](#) and [Figure 12-6](#) for the FGU schematics.

2.4.4.1 Reference Oscillator Y200

The radio's frequency stability and accuracy derive from the Voltage-Controlled Temperature-Compensated Crystal Oscillator (VCTCXO), Y200. This 16.8 MHz oscillator is controlled by the voltage from the WARP pin of the FracN IC, U202, that can be programmed through a serial peripheral interface (SPI). The oscillator output at pin 3 is coupled through capacitor C234 to the FracN synthesizer reference oscillator input and through C236 to the non-invertive input of the op-amp, U201.

Op-amp U201 buffers the 16.8 MHz output to the VOCON board. Components L205 and C214 form a low-pass filter to reduce harmonics of the 16.8 MHz.

The Digital-to-Analog Converter (DAC) IC, U203, and Switched Capacitors Filter (SCF) IC, FL200, form the interface between radio's DSP and the analog modulation input of the FracN IC.

2.4.4.2 Fractional-N Frequency Synthesizer (FracN) IC U202

The FracN IC, U202, is a mixed-mode, Motorola-proprietary, CMOS, fractional-N frequency synthesizer with built-in dual-port modulation. The SSE 5000 radio uses a low-voltage version of the device, sometimes called LVFracN, for compatibility with the 3 V logic used throughout the radio.

The FracN IC incorporates frequency division and comparison circuitry to keep the VCO signals stable. The FracN IC is controlled by the MCU through a serial bus. All of the synthesizer circuitry is enclosed in rigid metal cans on the transceiver board to reduce interference effects.

Separate power supply inputs are used for the various functional blocks on the IC. Inductors L203 and L204 provide isolation between supply pins 20 (AVDD) and 36 (DVDD) connected to Vdd3. Host control is through a three-wire, smart SPI interface (pins 7, 8, and 9) with a bi-directional data pin. FracN functions include frequency synthesis, reference clock generation, modulation control, voltage multiplication and filtering, and auxiliary logic outputs.

2.4.4.2.1 Synthesizer

Frequency synthesis functions include a dual-modulus prescaler, a phase detector, a programmable loop divider and its control logic, a charge pump, and a lock detector output. Fractional-N synthesizer IC principles of operation are covered in detail in the manufacturers' literature. No similar discussion will be attempted here.

2.4.4.2.2 Clocks

U202, pin 23 (XTAL1), is the 16.8 MHz reference oscillator input from the VCTCXO (Y200).

2.4.4.2.3 Modulation

To support many voice, data, and signaling protocols, the SSE 5000 radio must modulate the transmitter carrier frequency over a wide audio frequency range, from less than 10 Hz up to more than 6 kHz. The FracN supports audio frequencies down to zero Hz by using dual-port modulation. The audio signal at pin 10 (MODIN) is internally divided into high- and low-frequency components, which modify both the synthesizer dividers and the external VCOs through signal MODOUT (pin 41). The IC is adjusted to achieve flat modulation frequency response during transmitter modulation balance calibration using a built-in modulation attenuator.

2.4.4.2.4 Voltage Multiplier and Superfilter

Pins 12 (VMULT3) and 11 (VMULT4) together with diode arrays D201 and D202 and their associated capacitors form the voltage multiplier. The voltage multiplier generates 11.5 Vdc to supply the phase detector and charge-pump output stage at pin 47 (VCP).

The superfilter is an active filter that provides a low-noise supply for the VCOs and VCOBIC. The input is regulated 5 Vdc from Vdd5 at pin 30 (SFIN). The output is superfiltered voltage FSF at pin 28 (SFOUT).

The output from pin 15 (VMULT1) is used as a clock for the SCF IC, FL200.

2.4.4.3 Loop Filter

The components connected to pins 43 (IOUT) and 45 (IADAPT) form a 3rd-order, RC low-pass filter. Current from the charge-pump output, IOUT, is transformed to voltage VCTRL, which modulates the VCOs. Extra current is supplied by IADAPT for rapid phase-lock acquisition during frequency changes. The lock detector output pin 4 (LOCK) goes to a logic “1” to indicate when the phased-lock loop is in lock.

2.4.4.4 VCO Buffer IC (VCOBIC)

The VCOBIC (U250) is an analog IC containing two NPN transistors for use as oscillators, an active-bias circuit, transmitter and receiver buffer amplifiers, and switching circuitry. The VCOBIC has three RF outputs:

- TX_OUT (pin 10)—the modulated transmitter carrier
- RX_OUT (pin 8)—the receiver first LO
- PRESC_OUT (pin 12)—connected to FracN pin 32 (PREIN) through a matching circuit

Transmit/receive control is a single 5.0 Vdc logic input, TRB_IN (pin 19). When TRB_IN is low, the receiver buffer is active and the transmitter circuits are disabled. The converse is also true.

This radio uses two external, discrete, varactor-tuned, Colpitts VCOs based on transistors Q211 and Q215. Bias current to the VCOs is switched on and off by transistors Q214 and Q210, which are controlled by FracN outputs AUX2 and AUX4. Transistors packaged in Q301 form a 3.3 Vdc-to-5 Vdc logic-level shifter for the signal from the FracN AUX3 pin to the VCOBIC.

2.5 VOCON Board

This section provides a detailed circuit description of the SSE 5000 VOCON (vocoder and controller) board.

NOTE: Refer to [Table 12-2](#) for a listing of VOCON schematics that will aid in the following discussion.

The VOCON board block diagram ([see Figure 2-7](#)) contains three functional blocks and six connector symbols.

The functional blocks consist of the following:

- **Controller and Memory:** The dual-core processor (U401) with the microcontroller unit (MCU) and a digital signal processor (DSP) in a single integrated circuit (IC) package, the SRAM (U403) and Flash (U402) memory devices.
- **Audio and Power:** The GCAP II (U501), a 5 Vdc linear regulator (U505), a 1.55 Vdc linear regulator, the audio pre-amplifier (U502), the audio power amplifier (U503), and the dual EEPOT (U509).
- **Interface Support:** The digital-support IC (U301) (Flipper), ESD protection circuitry, and side connector interface circuitry.

The connector symbols represent the following:

- Transceiver board connector
- Universal flex connector
- Internal speaker and microphone flex connector
- Control top flex connector
- Liquid-crystal display (LCD) board connector
- Encryption module connector (optional)

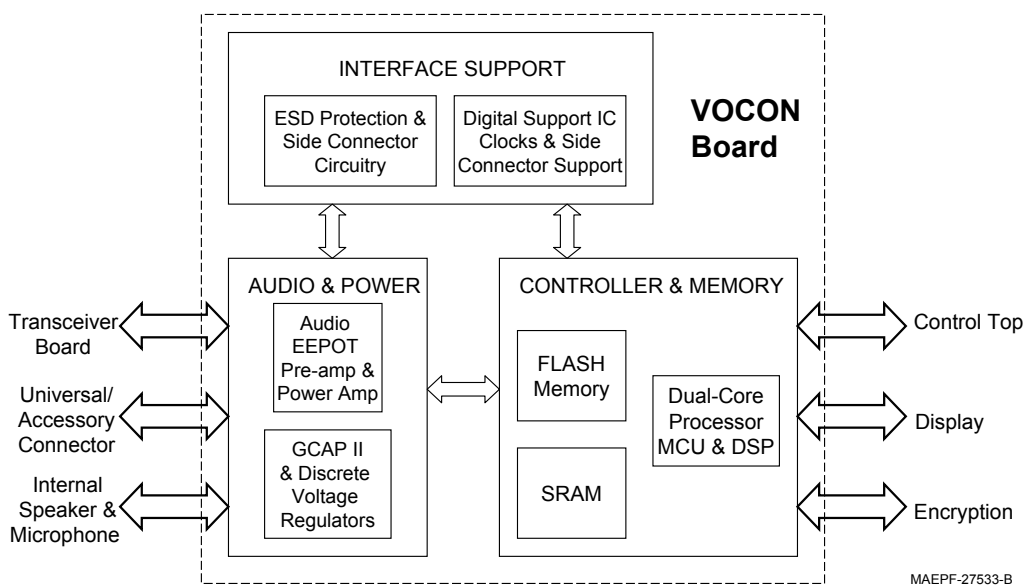


Figure 2-7. VOCON Board Block Diagram

2.5.1 Interconnections

2.5.1.1 Transceiver Board Connector P201

This is a 26-pin compression connector that interfaces between the VOCON board and the transceiver board. See [Section 2.4.1.2: "VOCON Connector P1" on page 2-7](#) for a detailed description of the interface between the VOCON and transceiver boards through P201.

2.5.1.2 Universal Flex Connector J102

This is a 40-pin connector that mates with the universal flex on the housing. A majority of the lines on the connector are for user interface: emergency and side buttons (pin 14), monitor button (pin 17), secure/clear switch (pin 23), channel switch (pins 24, 25, 26, and 27), volume knob (pin 31), and the three-position toggle switch (pin 34). The LEDs on the universal flex are controlled through pins 20,

21, and 22. Connections to the external accessory connector, which include serial communication data lines, external audio, and option select lines for controlling audio modes, are present at pins 1 through 13. Switched battery voltage (B+SENSE) is provided on pin 32. Most of the pins at this connector have ESD protection devices and components. See [Section 2.5.2.3.3: “Universal Connector Interface Circuitry” on page 2-29](#) for more details on this connection circuitry.

2.5.1.3 Internal Speaker and Microphone Flex Connector M102

The audio switching between the internal and accessory microphones is controlled via flex connector M102. See [Section 2.5.2.2.1: “GCAP II IC U501” on page 2-24](#) for a discussion of this audio switching.

2.5.1.4 Control Top Flex Connector J707

The control top switches and side controls are connected through a flex circuit to the controller at J707. See [Section 2.5.4: “Controls and Control Top Flex” on page 2-31](#) for a discussion of these controls.

2.5.1.5 Encryption Module Connector J701

This 40-pin connector provides the interface between the VOCON board and the encryption module. Two voltages are provided to the encryption board: UNSWB+ and SWB+. The SAP (Serial Audio Port) SSI lines, serial communication data lines, and general-purpose I/O lines from the dual-core processor are included in the interface to the encryption board.

2.5.1.6 Display Module Connector J301

This 20-pin connector (J301) mates the VOCON board to the display module flex. The VOCON kits have a serial data interface to the display module. In this design, only 2.9 V is provided to the display module on pins 11 and 14. The display’s serial dataline (pin 18), serial clock line (pin 7), and chip select line (pin 3) are at 2.9V logic levels. See [Section 2.5.3: “Display Module” on page 2-31](#) for details on the display module.

2.5.2 Functional Blocks

2.5.2.1 Controller and Memory

The controller and memory section contains the following components:

- Dual-core processor (U401), which acts as both the microcontroller unit (MCU) and the digital signal processor (DSP) for the radio
- Static RAM (SRAM) IC (U403), a volatile device, which is used as working memory and shares the address and data bus with the Flash memory device
- Flash memory IC (U402), which contains host firmware, DSP firmware, and some codeplug data

2.5.2.1.1 Dual-Core Processor U401

The dual-core processor U401 contains a 32-bit microcontroller unit (MCU) and a 16-bit digital signal processor (DSP) in one IC package. It comes in a 256-pin, ball-grid array (BGA) package with 1mm pitch solder balls. Most of the pins on the dual-core processor operate from the 3 V supply. A 1.55 V supply is used for the core voltage and the clock amplifier module. The remaining pins of the processor use a 2.9 V supply. The External Interface Module (EIM) utilizes a 1.85 V supply.

There are also two system clocks provided to the dual-core processor.

Microcontroller Unit (MCU)

The MCU portion of the dual-core processor controls receive/transmit frequencies, power levels, display, and other radio functions, using either direct logic control or serial communications paths to the devices. The microcontrol unit executes a stored program located in the FLASH memory device. Data is transferred to and from memory by the microcontrol unit data bus. The memory location from which data is read, or to which data is written, is selected by the address lines. The microcontrol unit requires a 16.8 MHz clock and a 32.768 kHz clock.

The MCU portion of the dual-core processor has 22.5k x 32 bits of internal RAM and 1k x 32 bits of internal ROM, which is used for the bootstrapping code. The MCU has several peripherals including an External Interface Module (EIM), the Multiple Queue Serial Peripheral Interface (MQSPI), two Universal Asynchronous Receiver/Transmitter (UART) modules, and the One-Wire Interface module. The MCU communicates internally to the DSP through the MCU/DSP Interface (MDI).

External Interface Module (EIM)

The External Interface Module (EIM) is the MCU interface to the SRAM U403 and Flash Memory U402. The EIM lines include 24 external address lines, 16 external bi-directional data lines, 6 chip selects lines, read/write line, and output enable line among others. All of the EIM lines operate at 1.8-V logic levels, and the EIM operates at the MCU clock speed.

Multiple Queue Serial Peripheral Interface (MQSPI)

The Multiple Queue Serial Peripheral Interface (MQSPI) is the MCUs programming interface to other ICs. The dual-core processor has two independent SPI busses, and each has its own clock line (test points SCKA and SCKB), data-out line (test points MOSIA and MOSIB), and data-in line (test points MISOA and MISOB). There are 10 SPI chip selects (SPICS) that are programmable to either SPI A, the transceiver board SPI bus, or to SPI B, the dedicated VOCON SPI bus.

The devices on the SPI A bus include the PCIC and FracN IC on the SPICS4 (R131), the Abacus III IC on SPICS5 (R126), an analog-to-digital converter (ADC) on SPICS6 (R133), and the serial EEPROM on SPICS7 (R132). The two SPI B chip selects are for the GCAP II IC U501 on SPICS2 (R539) and the digital-support IC U301 on SPICS3. All of the SPI module lines operate at GPIO voltage logic levels.

There are several devices on the transceiver board that only have one bi-directional SPI data line. Components U404, U405, and U406 are configurable by MCU GPIO pin TOUT13 (MISOA_SEL) to route the data line to the appropriate pin on the dual-core processor depending on which SPI device is being accessed.

Universal Asynchronous Receiver/Transmitter (UART)

The dual-core processor has two Universal Asynchronous Receiver/Transmitter (UART) modules. UART1 handles the RS232 lines while UART 2 is connected to the SB9600 lines. Each UART has a receive data line (URXD), a transmit data line (UTXD), and hardware flow control signals (RTS—request to send) and (CTS—clear to send). All UART lines operate at GPIO voltage logic levels. The translation to 5 V logic levels for the accessory side connector is discussed in [Section 2.5.2.3.1: “Digital-Support IC U301” on page 2-26](#).

One-Wire Interface

The MCU has a One-Wire Interface module that is used to communicate to a One-Wire device like a USB cable or a smart battery using the Dallas Semiconductor protocol. This module uses a GPIO voltage logic level.

Digital Signal Processor (DSP)

The DSP portion of the dual-core processor performs signaling and voice encoding and decoding, as well as audio filtering and volume control. The DSP performs Private-Line/Digital Private-Line (PL/DPL) encode and alert-tone generation. The DSP transmits pre-emphasis on analog signals, and applies a low-pass (splatter) filter to all transmitted signals. The DSP controls squelch, deviation, and executes receiver and transmitter filtering. The DSP executes a stored program located in the FLASH memory device.

The DSP requires a 16.8 MHz clock. The DSP uses the 16.8 MHz clock to generate a 256 kHz clock and an 8 kHz frame synchronization signal that is supplied to the CODEC. Additionally, the DSP requires clock and frame synchronization from the Abacus III digital back-end IC on the transceiver board to generate another clock and frame synchronization signal, and these signals are supplied to transmit DAC on the transceiver board.

The DSP has 84k x 24 bits of program RAM and 62k x 16 bits of data RAM. It has its own set of peripherals including the Baseband Interface Port (BBP), the DSP Timer module, and the Serial Audio CODEC Port (SAP). Additionally, the DSP shares some peripherals with the MCU, including the USB interface and the General Purpose Input/Output module (GPIO).

Baseband Interface Port (BBP)

The Baseband Interface Port (BBP) module is the DSP's serial synchronous interface (SSI) to the transceiver board. The BBP has independent sections for the receiver and the transmitter. The receiver BBP pins include the receive data pin SRDB (U703 pin 4), the receive clock signal pin SC0B (U705 pin 4), and the receive frame synchronization (sync) signal pin SC1B (U704 pin 4). The transmitter's BBP pins include the transmit data pin STDB (R717), the transmit clock signal pin SCKB (R715), and the transmit frame sync signal pin SC2B (R711). All BBP lines use GPIO voltage logic levels.

DSP Timer Module

While the BBP receive clock and frame sync signals are supplied by the Abacus III IC from the transceiver board, the BBP transmit clock and frame sync signals are generated by the DSP Timer. The BBP receive clock, connected to the DSP Timer input pin T10, is reference used to generate the BBP transmit clock and frame sync signals. These two signals, along with the BBP transmit data signal, are connected to the DAC on the transceiver board.

Serial Audio CODEC Port (SAP)

The Serial Audio CODEC Port (SAP) module is the DSP's serial synchronous interface (SSI) to the audio CODEC on the GCAP II IC. The SAP also interfaces with the encryption module.

The SAP interface consists of four signals including the SAP clock line pin SCKA (component R405), the SAP frame sync line pin SC2A (component R406), the SAP receive data line pin SRDA (component R402), and the transmit data line pin STDA (component R403).

The SAP clock is generated by the dual-core processor U401, and is a 256 kHz, 2.9 V peak-to-peak square wave. The SAP frame sync signal is generated by the dual-core processor U401, and is an 8 kHz, 2.9 V peak-to-peak square wave.

Universal Serial Bus (USB)

The dual-core processor USB peripheral, shared by the MCU and the DSP, provides the required buffering and protocol to communicate on the Universal Serial Bus. The dual-core processor supports USB slave functionality.

The receive data path is routed from the discrete USB receiver (U302 pin 8) and is buffered by U308. Single-ended positive data is generated at U302 pin 3 and is sent to the dual-core processor pin URXD_RTS.

USB data minus comes from U302 pin 4 and this signal is sent to URXD1 of the dual-core processor.

General-Purpose Input/Output (GPIO) Module

The General-Purpose Input/Output (GPIO) module is shared by the MCU and the DSP. This module consists of four 16-pin bi-directional ports and a 15 pin bi-directional port. While some of the pins on these ports are being used for other functions (UART, SPI, SAP, BBP, and Interrupt pins), the remaining pins can be programmed to become GPIOs that can be used by either the DSP or the MCU. Each GPIO pin has up to 8 alternate output functions and up to 4 alternate input functions.

This allows for the GPIO pins to be routed internally to pertinent dual-core processor modules. Additionally, the GPIO module adds selectable edge-triggered or level-sensitive interrupt functionality to the GPIO pins. Some examples of GPIO pins include the Audio PA control signals (EXT_SPKR_SEL, AUDIO_PA_EN, and AUDIO_MODE_SEL), the EEPROM control signals (EEPOT_INC*, EEPROM_U_D*, EEPROM_CS*, and EEPROM_CS_EXT*), and the LED control signals (RED_LED and GREEN_LED).

System Clocks

Two main clocks are provided to the dual-core processor. The first clock, a 16.8 MHz sine wave, comes from the RF interface connector P201 pin 7. This is the most important clock, since it is used internally to generate the clocks for both the MCU and DSP cores, as well as most of the peripherals. It is conditioned by the clock buffer circuit, which includes Q601, R603, R605, R615, L601, C606, C609, R608, and C607. The output of this buffer (C452) goes to the dual-core processor CKIH pin, as well as to the digital-support IC REF_16_IN.

The other clock supplied to the dual-core processor is a 3 V peak-to-peak 32.768 kHz square wave (32 kHz test point). It is generated by the digital-support IC U301 internal oscillator and an external 32.768 kHz crystal Y301, and is supplied to the CKIL pin on the dual-core processor. While not as widely used as the 16.8 MHz clock, the 32.768 kHz clock is needed by some components in the dual-core processor, including the reset circuitry.

2.5.2.1.2 Static RAM (SRAM) U403

The static RAM (SRAM) IC U403 is an asynchronous, 1 MB, CMOS device that is capable of 70 ns access speed. It is supplied with 1.8 volts. The SRAM has its 19 address lines and 16 data lines connected to the EIM of the dual-core processor through the Address(23:0) and Data(15:0) busses.

The SRAM has an active-high chip select CS2 that is tied directly to the 1.8 V supply and an active low chip select CS1 that is connected to the EIM CS2_N pin (test point CS2). When the SRAM CS1 pin is not asserted, the SRAM is in standby mode, which reduces current consumption.

Two other control signals from the EIM that change the mode of the SRAM are the read/write signal, R/W, and the output enable signal, OE. The R/W of the EIM is connected to the SRAM EN_WE pin (test point R_W), while the OE signal from the EIM is connected to the SRAM EN_OE pin. The SRAM is in read mode when the EN_WE pin is not asserted and the EN_OE pin is asserted. The SRAM is in write mode when the EN_WE pin is asserted, regardless of the state of the EN_OE pin.

The other SRAM pins are the lower-byte enable pin LB and the upper-byte enable pin UB. These pins are used to determine which byte (LB controls data lines 0-7 and UB controls data lines 8-15) is being used when there is a read or a write request from the dual-core processor. The LB pin is controlled by the EIM EB1_N signal, while the UP pin is controlled by the EB0_N signal.

2.5.2.1.3 FLASH Memory U402

The Flash memory IC is an 8 MB CMOS device with simultaneous read/write or simultaneous read/erase operation capabilities with 70 ns access speed. It is supplied with 1.8 volts. The Flash memory has its 22 address lines and 16 data lines connected to the EIM of the dual-core processor through

the Address(23:0) and Data(15:0) busses. The Flash memory contains host firmware, DSP firmware, and codeplug data with the exception of the tuning values that reside on the transceiver board's serial EEPROM. The Flash memory IC is not field repairable.

The RESET_OUT of the dual-core processor is at a GPIO voltage logic level. Components D401 and R401 are used to convert the voltage down to a 1.8 V logic level, and this 1.8 V reset signal is fed to the Flash RESET pin. When this pin is asserted (active low logic), the Flash is in reset mode. In this mode, the internal circuitry powers down, and the outputs become high-impedance connections.

The Flash active-low chip select pin, EN_CE, is connected to the active-low CS0_N pin (CS0 test point) of the EIM. When the EN_CE is not asserted, the Flash is in standby mode, which reduces current consumption.

Several other active-low control pins determine what mode the Flash memory is in: the address valid pin ADV that is connected to the EIM LBA_N signal, the output enable pin EN_OE that is connected to the EIM OE_N signal, and the write enable pin EN_WE that is connected to the EIM EB1_N signal. For read mode, the ADV and EN_OE pins are asserted while the EN_WE pin is not asserted. When the EN_WE is asserted and the EN_OE pin is unasserted, the Flash operates in the write mode.

Figure 2-8 illustrates the EIM and memory ICs block diagram.

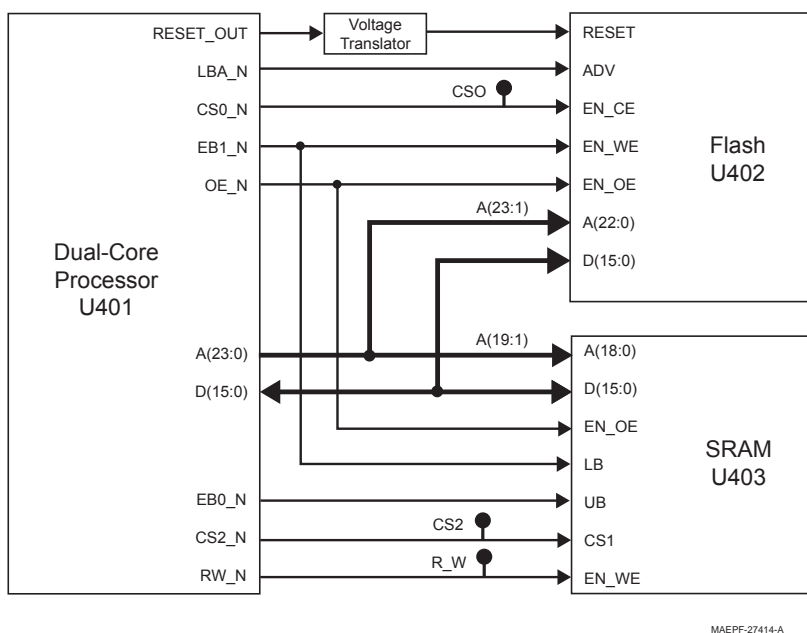


Figure 2-8. Dual-Core Processor EIM and Memory Block Diagram

2.5.2.2 Audio and Power

The audio and power section contains the following components:

- GCAP II IC U501
- 5 V regulator U505
- 1.55 V regulator
- Audio pre-amplifier U502
- Audio power amplifier (PA) U503
- EEPOT U509

The audio and power supply IC (GCAP II IC) has many functions. It supplies most of the voltages used on the VOCON board, while external linear regulators supply 5 Vdc and 1.55 Vdc. It also has microphone audio amplifiers, switching between internal and accessory microphones, multiplexing capability for receive and transmit audio, filtering, voltage regulators, a real-time clock (RTC), and the audio CODEC. The audio CODEC performs analog-to-digital and digital-to-analog conversions on audio signals. The GCAP IC also has an analog/digital converter (ADC), which is used to monitor volume setting and battery voltage. The GCAP II IC is programmed by the dual-core processor.

The audio pre-amplifier and the audio PA condition the received audio signal from the analog output of the CODEC from the GCAP IC before the audio is routed to the speaker. The dual EEPOT sets the gain of the microphone signal. The audio PA is sourced from the battery, and both of these devices are programmed by the dual-core processor.

2.5.2.2.1 GCAP II IC U501

The GCAP II IC is a mixed-signal (analog and digital) IC that provides control, audio, and voltage regulation functionality. It comes in a 100-pin, ball-grid array (BGA) package with 0.8 mm pitch solder balls. The GCAP II IC is supplied with switched battery voltage GCAP_B+ (R581).

Voltage Regulation

The GCAP II IC contains several voltage regulators that are used in the design of the VOCON board: VSW1, VSW2, and V2. The VSW1 regulator is a programmable switching regulator that uses the switched battery voltage as its input on pin PSRC1. The output voltage of VSW1 (R502) is programmable by the dual-core processor U401 through the SPI bus. The initial output of VSW1 is 3.2 volts, which is then programmed to 3.8 volts. The VSW1 voltage is supplied to the RF Interface connector P201 pin 15 and to the input pins of the VSW2 and V2 regulators.

The VSW2 regulator is a SPI programmable switching regulator that uses VSW1 as its input on pin PSRC2. The initial output of VSW2 (R501) is 2.2 volts, which is then programmed to 1.875 volts (referred to as 1.8 volts throughout this document). The VSW2 voltage is supplied to the dual-core processor (core voltage and the EIM voltage), the SRAM U403, the Flash memory U402, and the display module connector J301

The V2 regulator is a SPI programmable linear regulator that uses VSW1 as its input on pin VIN2. The initial output of V2 (R560) is 2.775 volts, which is then programmed to 2.9 volts. The V2 voltage is supplied to the dual-core processor (I/O ring - SPI, BBP, SAP, UART, GPIO, etc.), the digital-support IC U301, the EEPOT U509, the display module connector J301, and the many discrete components that interface with the dual-core processor and the digital-support IC.

MCU Interface

The GCAP II IC has a four-wire, SPI connection to the dual-core processor (SPI B). The SPI B clock is connected to the SPI_CLK pin (test point SCKB). The SPI B MOSI line is connected to the SPI_DW pin (test point MOSIB). The SPI B MISO line is connected to the SPI_DR pin (test point MISOB). The GCAP SPI B chip-select signal is connected to the CE pin (R539). Through this interface, the dual-core processor can program the voltage regulators, the CODEC, the transmit and receive audio filters and amplifiers, as well as read information from the ADC and the real-time clock.

The GCAP II IC has an 8-bit ADC with general-purpose six channels and four voltage-monitoring channels. The six general-purpose analog-to-digital (A/D) channels are assigned to the display backlight button on the control head (AD0), the monitor volume (AD5); the two-position toggle switch (AD1); the OPT_SEL_IN (AD2) (for determining accessory attachment), VOCON board ID (AD3), and RF board ID (AD4). Battery voltage is also monitored by the ADC. The dual-core processor activates and reads the A/D values through the SPI bus.

Audio Circuitry

A 13-bit CODEC, internal to the GCAP II IC and programmable by the dual-core processor through the SPI bus, converts microphone audio into a digital bit stream for processing by the DSP. The CODEC also converts receive audio data that was processed by the DSP into an analog audio signal for amplification to a speaker. The CODEC interfaces to the DSP through the 4-wire SAP bus. The CODEC clock, which is 256 kHz and is supplied to the DCLK pin. The CODEC 8 kHz CODEC frame synchronization signal is supplied to the FSYNC pin. The CODEC transmit data signal is on the TX pin, while the CODEC receive data signal is on the RX pin. For the CODEC to operate with those clock and frame sync signals, a 13 MHz clock (R302), generated by the digital-support IC, is supplied to the GCAP CLK_IN pin.

The GCAP II IC contains internal amplification, filtering, and multiplexing functionality for both receive and transmit audio. These functions are dual-core processor-programmable through the SPI bus. The input for the internal microphone audio (R540) is the MICIN_NEG pin, while the input for the external microphone audio (R566) is the AUX_MIC_NEG pin. The output for the speaker audio is the EXTOUT pin (C533).

2.5.2.2.2 5 V Regulator U505

The 5 V regulator uses UNSW_B+ as its input voltage. The digital-support IC WDI line controls the regulator's SHUTDOWN pin. The 5 V supply (R503) is used by the digital-support IC U301, audio preamplifier U502, microphone bias circuitry (R531 and R563), digital-support IC protection diodes, bi-directional voltage translators, battery data-line isolation circuitry, and ESD protection circuitry.

2.5.2.2.3 1.55 V Regulator

The 1.55 V regulator is made up of the following components: R600, Q600, U600, C601, C600, R601, R602, R617, C605, C603, and C604. This circuit uses VSW1 to bias the regulator while VSW2 sources the current. This voltage is used by the dual-core processor U401 for its core voltage and clock amplifier.

2.5.2.2.4 Audio Pre-Amplifier U502

The audio pre-amplifier U502 is a single-package, 5-pin, op-amp supplied with 5 volts. This pre-amp is an active low-pass filter and provides a fixed gain, which is selected by the components R551 and R537. The input (U502 pin 4) of stage is the EXTOUT pin from the GCAP II IC, while the output (U502 pin 1) of this stage goes to the audio PA.

2.5.2.2.5 Audio Power Amplifier U503

The audio PA U503 consists of two BTL amplifiers, complementary outputs, and control logic. Each of the amplifiers has a fixed gain—the external audio PA gain is set by components R553 and R554, while the internal audio PA gain is set by components R549 and R550.

The MODE pin (U503 pin 4) voltage determines the operation of the amplifier. That voltage is controlled by the dual-core processor GPIO lines AUDIO_PA_EN (to Q505) and AUDIO_MODE_SEL (to Q506). [Table 2-9](#) describes how the dual-core processor GPIO lines configure the audio PA.

The SELECT pin (U503 pin 6) is used to switch the audio path between internal and external speaker. The voltage on that pin is determined by the EXT_SPKR_SEL line from the dual-core processor and the Q505 transistor. When the voltage at the SELECT pin is high (B+), the audio is routed to the internal speaker lines. When the voltage at the SELECT pin is low ($V_{select} < 0.5V$), the audio is routed to the external speaker lines.

Table 2-9. Audio PA Status

AUDIO_PA_EN	AUDIO_MODE_SEL	Audio PA Status	MODE Voltage
0	0	Standby	$V_{\text{Mode}} > 7 \text{ V}$
0	1	Mute	$1.5 \text{ V} < V_{\text{Mode}} < 6 \text{ V}$
1	0	On	$V_{\text{Mode}} < 0.5 \text{ V}$
1	1	On	$V_{\text{Mode}} < 0.5 \text{ V}$

2.5.2.2.6 EEPOT U509

The EEPOT is a digitally programmable potentiometer with 256 taps and a total resistance of 50 Kohms. This 10-pin package contains two independent potentiometers, one for each microphone line. The EEPOT resistance values are programmed by the dual-core processor GPIOs EEPOT_INC* (U509 pin 9) and EEPOT_U_D* (U509 pin 2). The EEPOT_INC* signal increments the resistance value up or down, which depends on the EEPOT_U_D* signal. The EEPOT_CS* line (U509 pin 10) is asserted when the internal microphone gain is being changed. Similarly, the EEPOT_CS_EST* (U509 pin 1) is asserted for external microphone gain changes. The EEPOT is supplied with voltage from the GCAP II V2 regulator.

2.5.2.3 Interface Support

The interface support section consists of the following:

- Digital-support IC U301
- ESD protection circuitry
- Universal connector interface circuitry

The digital-support IC contains a USB transceiver, switching logic between RS232 and boot data path, One-Wire side connector support, and several clock generators. The digital-support IC is programmed by the dual-core processor.

ESD protection devices include zener diodes and low-capacitance ESD suppressors.

Side connector interface circuitry includes current-limiting resistors and noise-suppressing shunt capacitors.

2.5.2.3.1 Digital-Support IC U301

NOTE: See [Figure 12-14. NCN6186_ VOCON Flipper Circuit on page 12-20.](#)

The digital-support IC U301 is an application-specific integrated circuit (ASIC) device designed for the SSE 5000. It is contained in a 64-pin μ BGA package with 0.8 mm pitch solder balls. The digital-support IC is supplied with 5 V and the processor's GPIO voltage. It is supplied with a 16.8 MHz clock from the transceiver board. Using this clock, the digital-support IC generates a 13 MHz clock for the GCAP II IC. Additionally, the digital-support IC uses a crystal to generate the 32 kHz clock used by the dual-core processor and GCAP II IC.

The digital-support IC supports many functions, including the radio's universal (accessory) side connector interface, One-Wire option detect support, watchdog timer, and 32 kHz oscillator with CMOS output. It also monitors the position of the on/off switch and controls the shutdown of the regulators on the GCAP II IC.

The digital-support IC is programmable by the dual-core processor through the SPI bus.

Side Connector Interface, Logic Level Translation, and Boot Data Path Control

The digital-support IC facilitates the interface to the radio's side connector. Some of the side connector lines are at 5 V logic levels, so the digital-support IC converts those lines to GPIO voltage logic levels to interface to the dual-core processor. These lines include the SB9600 bus busy line LH_BUSY (R242), and the RS 232 CTS (R245). The SB9600 data line uses an external, bi-directional, voltage translation circuit that includes Q304, D302, R328, R329, R330, U303, and C314.

USB Transceiver

The USB transceiver, U302, is capable of transmitting and receiving serial data at a rate of 12 megabits per second. The differential USB data comes from the side connector, through the 33-ohm resistors R252 and R253 and the isolation switch Q301, and then to the VP and VM pins on U302. The USB receive interface from the digital-support IC to the dual-core processor is as follows: VP routed to PA2_USB_VPIN VM, routed to USB_VMI_RXD, and the differential decoded data is output at the RCV pin and goes to the dual-core processor URTS1 pin.

The USB transmitter is enabled when the SUSPND and OE_EN signals are both driven low by the dual-core processor. The single-ended data is output from the dual-core processor on the UTXD1 pin and goes to VO_VPO on U302. The data is driven out differentially on the DPOS and DNEG pins, which go to the side connector. The dual-core processor sends the single-ended zero signal from pin PC0_USB_VMOUT to the FSE0_VMO pin on U302.

When a USB cable is detected, Q302 pin 2 goes high. This controls the isolation switch Q301 so that the data that is on those lines are routed to the USB transceiver. If a USB cable is not detected, the Q302 pin is low and the USB transceiver is isolated. This isolation is done primarily because the RS232 data lines are 5 V lines, so the switch protects the transceiver since it operates at a lower voltage, and the USB data lines to the side connector also act as the RS232 lines.

On the VOCON board, the USB transceiver on the digital-support IC is not used. Instead, a discrete USB transceiver U310 is used. The transceiver is provided with 5 V and 2.9 V. The 5 V powers an internal 3.3 V voltage regulator on the transceiver, which is used as the voltage for the USB data pins D+ and D- as well as the VPU pin. The 2.9 V is used by the remaining pins as they interface to the dual-core processor U401.

One-Wire Support

New options and accessories that attach to the side connector are identified by the dual-core processor using the One-Wire protocol. The One-Wire pin on the side connector serves as the One-Wire data pin. This signal is connected to the ONE_WIRE_OPT pin. This pin is connected to the dual-core processor One-Wire bus ONE_WIRE_UP through an internal isolation switch controlled by a dual-core processor GPIO line to the digital-support IC ONE_WIRE_EN_X pin. This isolation is needed to prevent possible contention on the One-Wire bus when a smart battery is attached to the radio.

These new accessories are to ground, CTS (TP208), of the side connector. When this occurs, the digital-support IC pin KVL_USB_DET_X is asserted and the dual-core processor detects the change. The dual-core processor then asserts the ONE_WIRE_EN_X pin on the digital-support IC to connect the side connector One-Wire line to the dual-core processor One-Wire bus. In the case of the USB cable, the dual-core processor reads the One-Wire data from the cable and, upon determining that a USB cable is attached, programs the digital-support IC for USB mode.

Watchdog Timer

The digital-support IC monitors the position of the radio's On/Off switch on the BP_SEN_X pin, and that signal is located on Q508 pin 3. If the voltage on pin 3 is ground, then the radio is turned on. If the voltage on pin 3 is 3 volts, then the radio is off. When the radio is turned off, a counter inside the digital-support IC begins incrementing. That counter can be refreshed by the dual-core processor through the SPI bus.

This is done so that the software has enough time to complete its tasks before the power is taken away from the dual-core processor. If the counter is not refreshed by the time the count is complete, the digital-support IC pin WD_OUT goes low, which shuts down the GCAP II voltage regulators. During normal radio operation, WD_OUT should be high (V2 regulated voltage).

32 kHz Oscillator and CMOS Output

The 32 kHz oscillator circuitry uses a separate voltage supply pin (VDD3_XTL) than the other 3-V portions of the digital-support IC. The oscillator circuitry is internal to the digital-support IC, and the 32.768 kHz crystal Y301 and additional load capacitors C308 and C309 are located next to the IC.

The output of the 32 kHz oscillator is an LI_CELL voltage (approximately 3 volts peak-to-peak), 32.768 kHz square wave on pin REF32_OUT. This clock goes to two destinations: the dual-core processor CKIL pin (32 kHz test point) as a square wave and the GCAP II IC XTAL1 pin (C306) as a sine wave.

Components C306 and C313 are used to filter the square wave into a sine wave before the signal goes to the GCAP II IC.

13 MHz Reference Generation for GCAP II IC

The 13 MHz reference is required by the GCAP II IC for the CODEC time base and the SSI clock generator module internal to the digital-support IC. A phase locked loop (PLL) is used to generate the 13 MHz using the 16.8 MHz clock, which is provided to the digital-support IC REF_16_IN pin (C307). An external RC loop filter network, consisting of R301, C301, and C302, is connected to the PLL_LFT pin.

The 13 MHz reference output pin, REF_13_OUT, is conditioned by the RC network of R302 and C303. The signal at REF_13_OUT is a 3-V peak-to-peak square wave, and the RC filter produces a lower-level triangle wave that is suitable for the GCAP II IC.

The 13 MHz reference is disabled as the digital-support IC powers up. The 13 MHz reference is enabled by the dual-core processor through the SPI bus, and, during normal radio operation, this signal should be present.

2.5.2.3.2 ESD Protection Circuitry

NOTE: See [Figure 12-13. NCN6186_ VOCON Universal Connector Circuit on page 12-19.](#)

Several components on the VOCON board protect the circuitry from ESD. The side connector signal lines have ESD protection components on them since they are exposed. These protection components include:

- 5.6-V zeners VR205, VR206, VR220, and VR221 on the SB9600 lines, RS232 lines, microphone lines, and option-select lines
- 12-V zeners VR201, VR203, and VR209 on the internal and external speaker and microphone audio lines
- 13-V zener VR204 on the OPTB+ line
- Low-capacitance ESD suppressors C205, C206, C209 D203, VR220, VR221, and VR205 on audio lines, USB datalines, and option-select lines

There were also several protection diodes on lines connected to the digital-support IC. These include C224, C225, C226, C227, VR205, and VR206. ESD protection for the battery status line is provided by a 5.6-V zener VR501.

2.5.2.3.3 Universal Connector Interface Circuitry

Some important components on the universal connector interface are two op-amps. The first op-amp, U201, is used as a unity-gain buffer for the option-select line. Similarly, the other op-amp, U202, is used as a comparator for the buffered option-select line. The comparator threshold is determined by the voltage-divider network of R240 and R243.

Universal Connector and Option Selects

The universal connector is located on the back of the radio. It is the external port or interface to the outside and is used for programming and interfacing to external accessories. The universal connector connects to the VOCON board at connector J102 via a flex circuit that is routed inside the external housing. [Figure 2-9](#) shows the pinout for the universal side connector, and [Table 2-10](#) shows the pin assignments. Connections to J102 on the VOCON board are shown in [Figure 2-10](#).

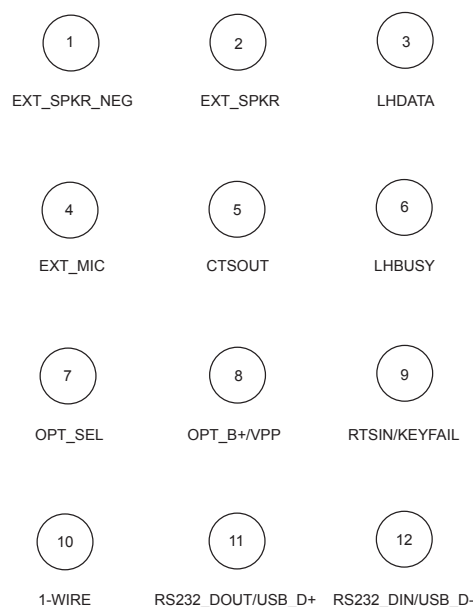


Figure 2-9. Universal Side Connector

Table 2-10. Pin Assignments for Universal Side Connector

Pin Number	Description
1	EXT_SPKR_NEG
2	EXT_SPKR_PLUS
3	LHDATA
4	EXT_MIC
5	CTS_OUT
6	LHBUSY
7	OPT_SEL
8	OPT_B+/VPP
9	RTSIN/KEYFAIL
10	1-WIRE
11	RS232_DOUT/USB+
12	RS232_DIN/USB-

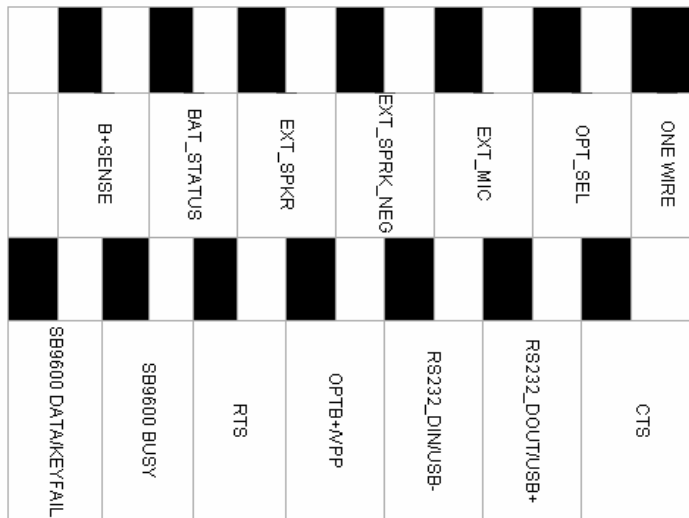


Figure 2-10. VOCON Board Connector J102

Most of the signals are extensions of circuits described in other areas of this manual. However, the option-select pin is used to configure special modes: option-select 1 and option-select 2. This pin is controlled by accessories connected to the universal connector.

Table 2-11 outlines their functions as defined at the universal connector.

Table 2-11. Option Select Functions

Function	Option Select Voltage
External PTT	< 0.30
External Audio & Internal Antenna	1.25
External Audio & External Antenna	2.50
No Accessory Attached	>4.40

2.5.3 Display Module

NOTE: The VOCON kit is only compatible with the 7285419E01 display module.

The 7285419E01 display module is an integral 112 by 32 pixel bit-mapped, liquid-crystal display (LCD) module. The display module is connected to the VOCON board through flex connector J301. It uses chip-on-film technology and is not field repairable.

The display module is controlled by the dual-core processor MCU core, which programs the display through the serial peripheral interface (SPI) bus. The SPI bus programs the display through the serial data line (pin 10), serial clock line (pin 7), chip select line (pin 3), and register select line (pin 6) that is used to select the register to be programmed. The dual-core processor can reset the display module through pin 2.

The display is supplied with 2.893V GCAP II regulated voltage (B700) to pins 11 and 14. Display backlighting is controlled by the dual-core processor GPIO line BL_EN signal through components R140 and Q101. The LEDs on the display module are powered by 5 V going through resistors R704, R705, and Q700.

2.5.4 Controls and Control Top Flex

The housing assembly top controls include the On/Off/Volume switch (S1), a 16-position Channel Select switch, and a programmable three-position (A,B,C) toggle switch (S2).

The side controls include three programmable pushbutton switches (top side button [SB1], side button 1 [SB2], side button 2 [SB3]) and a Push-to-Talk (PTT) switch (SW2). These components are connected through a flex circuit to the controller at J707.

UNSW_B+ is routed through switch S1 to provide the B+SENSE signal, which is used to activate the SW_B+ and GCAP_B+ voltages that, in turn, power up the radio. Volume control is also provided by S1, which contains a potentiometer biased between V2 regulated voltage and ground. The VOL signal is a voltage level between V2 regulated voltage and ground, depending on the position of the knob. The VOL signal is fed to buffer U506 pin 3, and then the output of the buffer is voltage-divided down to 2.5 volts before the signal goes to the GCAP II IC AD5 pin. The dual-core processor reads the GCAP II IC A/D value through the SPI bus, and from this reading, the dual-core processor DSP adjusts the speaker volume.

Switch S2 is the three-position, programmable, toggle switch typically used for zone selection. The switch can output the following voltages: 0 volts, half of the V2 regulated voltage, or V2 regulated voltage (measurable at R523). The switch is connected to the GCAP II IC AD1 input pin through the voltage divider network of R519 and R523. The dual-core processor reads the A/D value through the SPI bus, and it uses that reading to determine the position of the toggle switch.

Programmable side buttons SB1, SB2, and SB3 are active-low (activated when side button voltage is 0V). When the side buttons are not pressed there are 2 V on the respective lines. S1 is a binary-coded switch. The output pins from U1, which are connected to GPIO pins on the dual-core processor, provide a four-bit binary word (signals RTA0, RTA1, RTA2, and RTA3) to the MCU, indicating to which of the 16 positions the rotary is set.

2.5.5 VOCON Audio Paths

This section describes the VOCON transmit and receive audio paths.

2.5.5.1 Transmit Audio Path

Refer to [Figure 2-11](#). The internal microphone audio enters the VOCON board through pin 8 of the M102 contact, and the internal microphone bias is set by circuitry that includes R531, R533, C519 and C521. The internal microphone signal is connected to the MICIN_NEG pin, which is the input terminal on the GCAP II IC internal op-amp A3. The gain of the A3 op-amp is set by the values of R540, R555, and the resistance of EEPOT U509 (digital potentiometer), which is programmed by dual-core processor GPIO lines.

The external microphone audio enters the VOCON board through the remote connector J102, pin 10, and the external microphone bias is set by circuitry that includes R563, R565, C547, and C548. The external microphone signal is connected to the AUX_MIC_NEG pin, which is an input terminal on the GCAP II IC internal op-amp A5. The gain of the A5 op-amp is set by the values of R566, R561, and the resistance of the EEPOT U509.

The dual-core processor, through the SPI bus, programs a multiplexer to select one of the microphone signals. Then, the selected amplified microphone signal goes through a programmable gain amplifier before it goes to the CODEC for A/D conversion. The resulting digital data is filtered and sent to the DSP on the SAP CODEC_TX line from the GCAP II IC TX pin. After additional filtering and processing, the DSP sends the data-out from the STDB pin to the RF interface connector P201 pin 4 (TX_DATA), which is connected to the DAC U203 on the transceiver board.

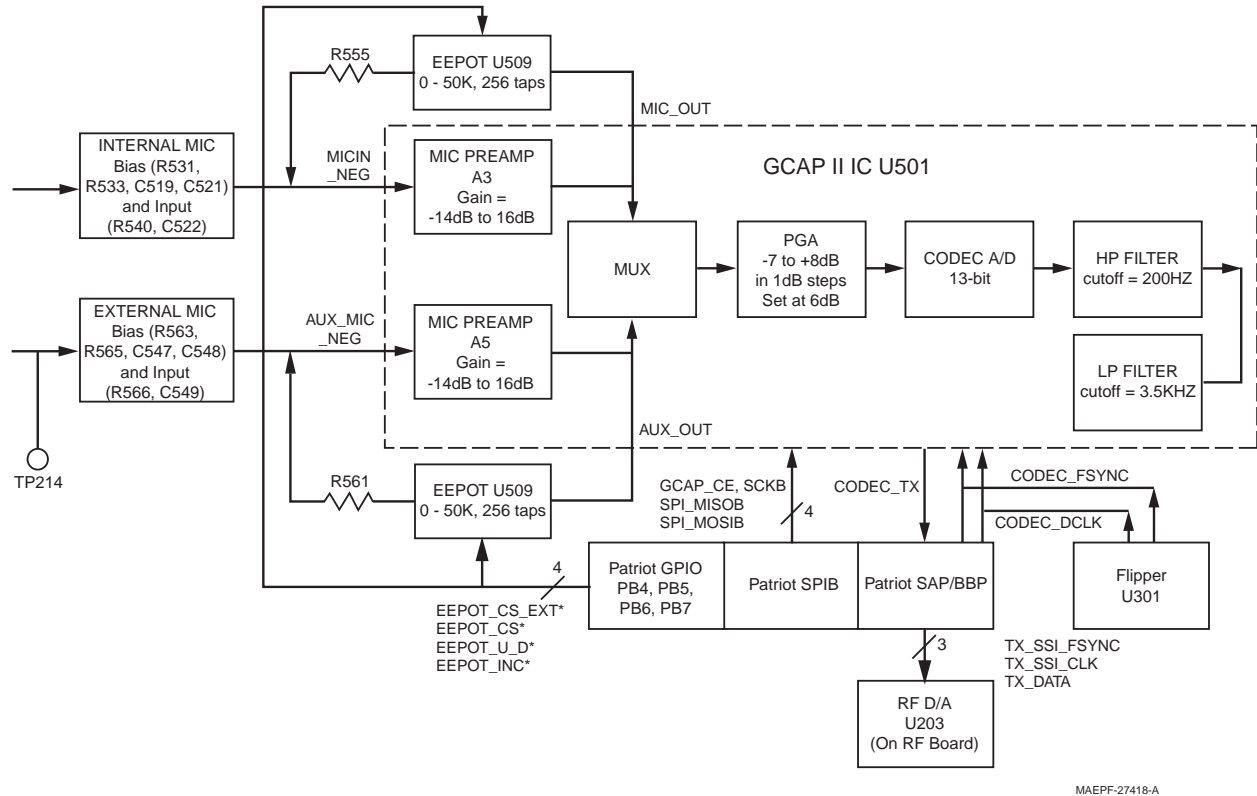
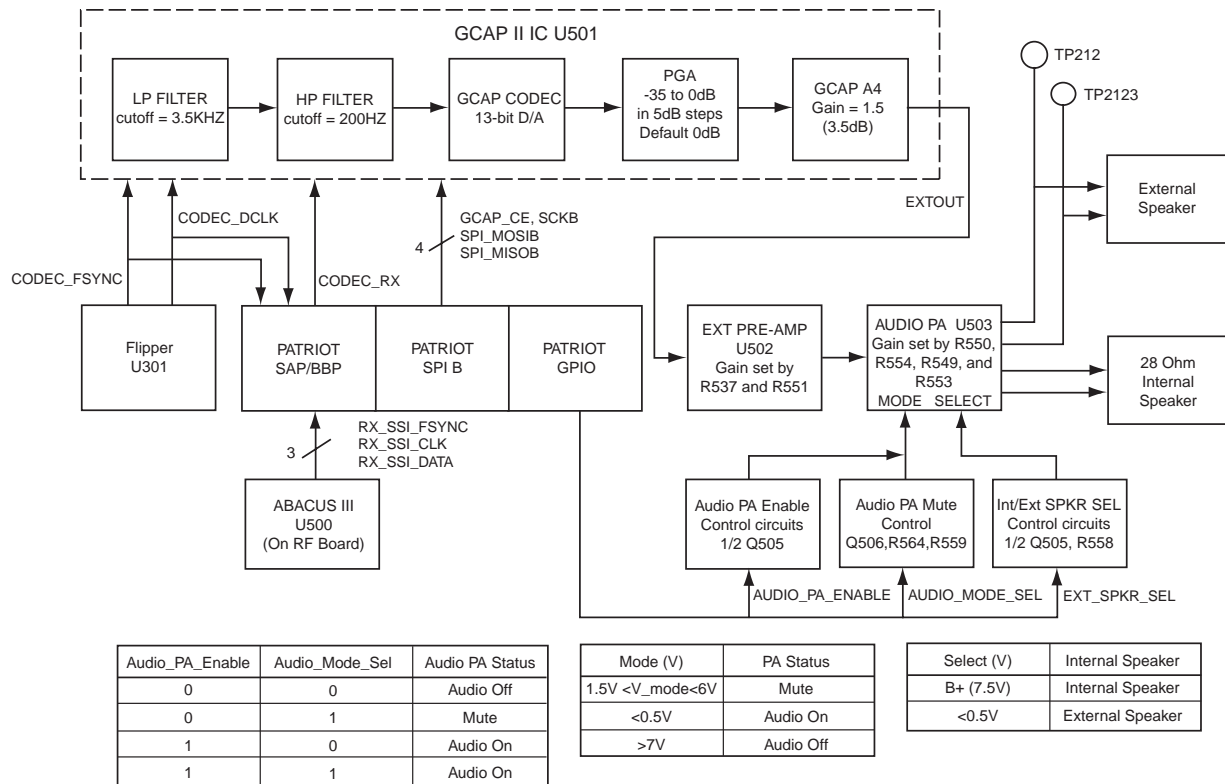


Figure 2-11. VOCON Transmit Audio Path

2.5.5.2 Receive Audio Path

Refer to [Figure 2-12](#). The receive audio data comes from the Abacus III IC U500 through the RF interface connector P201 pin 12 (RX_DATA) to the dual-core processor SRDB pin. The DSP decodes the data and sends it out through the CODEC_RX line to the GCAP II IC RX pin. The CODEC filters and converts the digital data into an analog audio signal, which, in turn, is sent to a programmable gain amplifier. The dual-core processor programs a multiplexer to route the audio signal to the A4 amplifier, which has a fixed gain of 3.5 dB. The output of the A4 amplifier is pin EXTOUT.

From the EXTOUT pin, the audio signal goes through the pre-amplifier U502 and then to the audio power amplifier U503, which together provide approximately 30 dB of gain. The dual-core processor selects whether the amplified audio is routed to the internal speaker or the external speaker.



MAEPF-27417-A

Figure 2-12. VOCON Receive Audio Path

2.5.6 Radio Power-Up/Power-Down Sequence

The radio power-up sequence begins when the user closes the radio On/Off switch on the control top, placing 7.5 Vdc on the B+SENSE line. This voltage enables the pass element Q501 and Q502, enabling SW_B+ and GCAP_B+.

When the GCAP II IC U501 detects a low-to-high voltage transition on GCAP_B+, it turns on and enables voltage supplies VSW1, VSW2, V2 and Vref. As soon as these voltages come up, the 1.55 V regulator ramps up (only on the VOCON board), and the digital-support IC U301 drives the WDI line high to enable VCC5 from regulator U505 and to maintain the GCAP II IC in the ON state. If WDI remains low, the GCAP II IC turns off 50 ms after turning on.

The radio power-down sequence begins by opening the radio On/Off switch, which removes the B+SENSE signal from the VOCON board. This does not immediately remove power because the GCAP II IC has control of Q502 through Vref, and U301 through WDI maintains the GCAP II IC in an active state. Both the MCU and digital-support IC monitor B+SENSE. After B+SENSE is removed, the digital-support IC waits 125 ms. before releasing WDI to allow for software cleanup; however, the software has the ability to prolong this time if it was necessary to complete its operations. When WDI is released, the GCAP II IC shuts down its supplies and the rest of the radio through Q501.

Chapter 3 Test Equipment and Service Aids

This chapter provides lists of test equipment and service aids, as well as information on field programming equipment that can be used in programming and servicing SSE 5000 radios at all of the three different levels of service.

3.1 Levels of Service

Level 1 service procedures, shown below, are all performed on the outside of the radio:

- Operating the radio
- Programming the radio
- Aligning the radio
- Checking radio performance

Level 2 service procedures are performed inside the radio, and include all Level 1 procedures, in addition to:

- Disassembling and reassembling the radio
- Replacing assemblies, controls, flexes, gaskets, connectors, microphones, speakers, etc.
- Replacing boards or modules

Level 3 service procedures include all Level 1 and Level 2 procedures, in addition to:

- Replacing components on boards or modules

[Table 3-1](#) lists the test equipment used to perform Level 1 service procedures. [Table 3-2](#) lists the service aids for all levels of service, and indicates the level for which each item is appropriate.

3.2 Test Equipment

The list of equipment contained in [Table 3-1](#) includes all of the standard test equipment required for servicing the SSE 5000 radio. The “Characteristics” column is included so that equivalent equipment may be substituted, as needed.

Table 3-1. Test Equipment

Motorola Model Number	Description	Characteristics	Application
R2670_ or equivalent	Communications System Analyzer	This monitor will substitute for items with an asterisk (*)	Frequency/deviation meter and signal generator for wide-range troubleshooting and alignment
Agilent 8901B or equivalent	Modulation Analyzer		Transmitter parameter testing: deviation balance and limit
R1717_, R1737_, R1738_ or equivalent	Digital Multimeter		Recommended for ac/dc voltage and current measurements
WPLN4124_R or equivalent	Battery Optimizing System (BOS)		

Table 3-1. Test Equipment (Continued)

Motorola Model Number	Description	Characteristics	Application
RL73063	BOS Adapter for SSE 5000		
R1512_ or equivalent	Function Generator with Benchlinks Software		
R1730_ or equivalent	120 W Single-Output DC Power Supply	0-20 Vdc, 0-5 Amps current limited	Bench supply for 7.5 Vdc
R1736_ or equivalent	Scopemeter	200 MHz	
R1150_ or equivalent*	Code Synthesizer		Injection of audio and digital signaling codes
R1736_ or equivalent*	Single-Channel Power/Voltmeter (AC)	1 mV to 300 V, 10-Megohm input impedance	Audio voltage measurements
R1733_, R1734_ or equivalent	Digital Dual-Trace Oscilloscope	20 MHz bandwidth 5 mV to 5 V/division	Waveform measurements
R1515_ or equivalent	Microwave Counter	225 MHz, frequency to 1.5 GHz	
R1440_ or equivalent*	Wattmeter	Fixed-Element, Broadband	Transmitter power output measurements
S1339_ or equivalent	RF Millivolt Meter	100 μ V to 3 V RF	RF level measurements
R1013_ or equivalent*	SINAD Meter		Receiver sensitivity measurements
HP8903_ or equivalent	Audio Generator		Used for RF tests (RX and TX)
	RF Generator		Must produce at least 1 GHz and FM modulation
RRDN4010_ or equivalent	Standard RF Probe Kit		
RRDN4011_ or equivalent	50-ohm Diode Power Sensor	500 KHz to 18 GHz, -70 to +20	
0180386A82 or equivalent	Anti-Static Kit	Includes wrist strap, ground cords, table mat and floor mat	Guards against electrostatic discharge
R1735_	Bandit Split Vision Rework System with Monitor		

3.3 Service Aids

Refer to [Table 3-2](#) for a listing and description of the service aids designed specifically for servicing this family of radios. These kits and/or parts are available from the Radio Products and Services Division offices listed in [“Appendix B: Replacement Parts Ordering”](#). While all of these items are available from Motorola, most are standard shop equipment items, and any equivalent item capable of the same performance may be substituted for the item listed.

Table 3-2. Service Aids

Motorola Part Number	Description	Application	Service Level
0180386A82	Anti-static grounding kit	Used during all radio assembly and disassembly procedures	1, 2, 3
RKN4121_	USB Cable Kit	Connects radio to RLN-4460 Portable Test Set for radio performance checks, and to Universal Serial Bus (USB) port on personal computer for CPS programming and tuner alignments.	1
RKN4122_	RS232 Cable Kit	Connects radio to RLN-4460 Portable Test Set for radio performance checks, and to serial port on personal computer for CPS programming and tuner alignments.	1
RLN4460_	Portable Test Set	Used for radio performance checks and alignments. Connects to radio's universal connector and allows remote switching and signal injection/outputs for test equipment measurements.	1
RTL4224_	Battery Eliminator	Used in place of battery to connect radio to an external power supply.	1
RVN4181_	Customer Programming Software (CPS) and Tuner Software	CPS allows customer-specific programming of modes and features. Tuner software required to perform alignment of radio parameters.	1
TKN8506_	Saber Keyload Cable	Connects radio to keyloader for loading encryption keys.	1
5880384G68	SMA-BNC Adapter	Adapts radio's female SMA antenna port to BNC cabling of test equipment.	1
RSX4043_	ROTO-TORQ Tool	Adjustable torque screwdriver	2
6680321B79	Phillips Head Star Bit	Bit used for attaching/detaching power contact screws.	2
6680370B88	Channel and Volume Switch Spanner Nut Bit	Bit used for attaching/detaching volume control and channel select switch spanner nuts.	2
6680371B34	Antenna Spanner Nut Bit	Bit used for attaching/detaching antenna spanner nuts.	2
6680387A74	T-10 Torx Bit	Bit used for attaching/detaching radio bolts.	2
8180384N70	Housing Eliminator	Special fixture that allows radio's internal board to be mounted externally. Provides easy access to electronic circuits, required for board-level troubleshooting.	2
R1453	Digital-readout solder station	Digitally controlled soldering iron	3

Table 3-2. Service Aids (Continued)

Motorola Part Number	Description	Application	Service Level
RLN4062	Hot-air workstation, 120V	Tool for hot-air soldering/desoldering of surface-mounted integrated circuits	3
0180386A78	Illuminated magnifying glass with lens attachment	Illumination and magnification of components	3
0180302E51	Master lens system		3
6684253C72	Straight prober		3
6680384A98	Brush		3
1010041A86	Solder (RMA type), 63/67, 0.5 mm diameter, 1 lb. spool		3
0180303E45	SMD tool kit (included with R1319A)		3
R1319	ChipMaster (110V)	Surface-mount removal and assembly of surface-mounted integrated circuits and/or rework station shields. Includes 5 nozzles.	3
R1321	ChipMaster (220V)		3
R1364	Digital heated tweezer system	Chip component removal	3
R1427	Board preheater	Reduces heatsink on multi-level boards	3
6680309B53	Rework equipment catalog	Contains application notes, procedures, and technical references used to rework equipment	3
ChipMaster Options:			
6680370B54	0.710" x 0.710"	Heat-focus heads for R1319 workstation	3
6680370B57	0.245" x 0.245"		
6680370B58	0.340" x 0.340"		
6680371B15	0.460" x 0.560"		

Table 3-2. Service Aids (Continued)

Motorola Part Number	Description	Application	Service Level
ChipMaster Nozzles:			
6680333E28	PA nozzle	Soldering and unsoldering ICs	3
6680332E83	PLCC-28* nozzle		
6680332E93	PLCC-32 nozzle		
6680332E82	PLCC-44* nozzle		
6680332E94	PLCC-52 nozzle		
6680332E95	PLCC-68* nozzle		
6680332E96	PLCC-84 nozzle		
6680332E89	QFP-80 nozzle		
6680332E90	QFP-100* nozzle		
6680332E91	QFP-132* nozzle		
6680334E67	QFP-160 nozzle		
6680332E86	SOIC-14/SOL-16J nozzle		
6680333E46	SOL-18 nozzle		
6680332E84	SOIC-20 nozzle		
6680332E87	SOL-20J nozzle		
6680333E45	SOL-24 nozzle		
6680332E88	SOL-28J nozzle		
6680333E54	TSOP-32 nozzle		
6680333E55	TSOP-64 nozzle		

* Included with ChipMaster packages



Caution

To maintain the integrity of the RF PA, **never heat it above 210°C** while performing repair or rework procedures. To prevent overheating the RF PA during rework, use a ChipMaster (R1319 or R1321) top-side pre-heat set point of 215°C and a Dragon (R1427) bottom-side pre-heat set point of 204°C for 1 minute before and throughout top-side heat application, assuming that the RF PA is removed from the applied heat 10 seconds after reflow occurs. (The RF PA temperature does not reach the ChipMaster's internal set point temperature). All other parts on the transceiver board can be reworked with ChipMaster top-side heat alone.

3.4 Field Programming

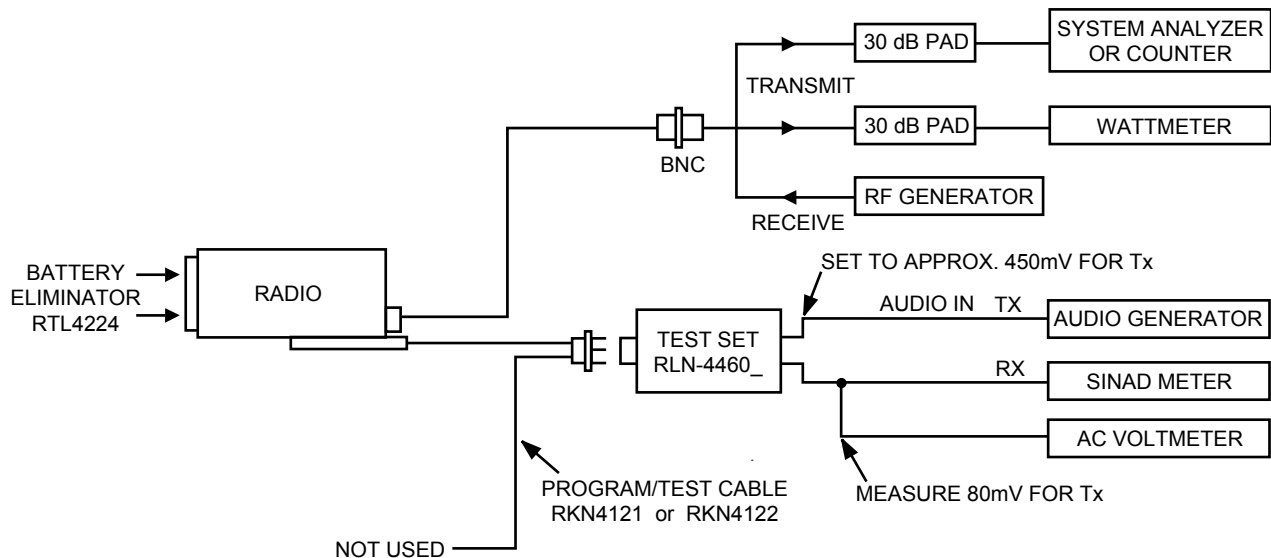
This family of radios can be aligned and programmed in the field. This requires specific equipment and special instructions. Refer to the Customer Programming Software (CPS) Installation Guide (Motorola publication part number 6881095C44) for information on installing the CPS, and to the on-line help in the CPS for complete field programming information. Refer to [Figure 2-9 on page 2-29](#) for the accessory connector pinout.

Chapter 4 Performance Checks

This chapter covers performance checks used to ensure that the SSE 5000 radio meets published specifications. The recommended test equipment listed in the previous section approaches the accuracy of the manufacturing equipment, with a few exceptions. Accuracy of the test equipment must be maintained in compliance with the manufacturer's recommended calibration schedule. Checks should be performed if radio performance degradation is suspected.

4.1 Test Equipment Setup

Supply voltage can be connected from the battery eliminator. The equipment required for the performance checks is connected as shown in [Figure 4-1](#).



MAEPF-27212-B

Figure 4-1. Performance Checks Test Setup

Initial equipment control settings should be as indicated in [Table 4-1](#) and should be the same for all performance checks and alignment procedures, except as noted.

Table 4-1. Initial Equipment Control Settings

System Analyzer	Test Set	Power Supply
Monitor Mode: Standard	Spkr/Load: Speaker	Voltage: 7.5 Vdc
Receiver Checks RF Control: GEN Output Level: -47 dBm Modulation: 1 kHz tone @3 kHz deviation Frequency: Set to selected radio RX frequency Meter: AC Volts Transmitter Checks RF Control: MONITOR Frequency: Set to selected radio TX frequency Meter: RF Display Modulation Type: FM Attenuation: 20 dB	PTT: OFF (center)	DC On/Standby: Standby
	Meter Out: RX	Volt Range: 7.5 Vdc
	Opt Sel: ON	Current: 2.5 Amps

4.2 Radio Test Mode

This section provides instructions for performing tests in display radio test mode.

4.2.1 Access the Test Mode

To enter the display radio test mode:

1. Turn the radio on.
2. Within 10 seconds of turning the radio on, press the **one-dot side button** five times in succession.

The radio shows a series of displays that give information regarding various version numbers and subscriber specific information. The displays are described in [Table 4-2](#).

NOTE: When you turn the radio on normally, the radio performs a limited self-test. To allow the radio to perform a full self-test, press and hold the **top side button** while turning the radio on. If the self-test is successful, you hear a chirp. If the self-test is unsuccessful, you hear a single, low-frequency tone and see an error code on the radio's display. See [Table 8-2 on page 8-2](#) for the power-up error codes.

Table 4-2. Test-Mode Displays

Display	Description	Appears
SERVICE	The radio has entered test mode.	Always
HOST VER, followed by the version number	The version of host firmware	Always
DSP VER, followed by the version number	The version of DSP firmware	Always
SECURE, followed by the version number	The version of encryption firmware	When the radio is secure equipped
KG, followed by the encryption type*	Type of encryption algorithm being used	When the radio is secure equipped and at least one encryption algorithm is installed
(Model number)	The radio's model number, as programmed in the codeplug	Always
(Serial number)	The radio's serial number, as programmed in the codeplug	Always
(ESN)	The radio's electronic serial number, as programmed in the codeplug	Always
(ROM size)	The memory capacity of the host FLASH part	Always
FLASHCOD, followed by the FLASH code(s)	The FLASH codes, as programmed in the codeplug	Always
UHFL	The RF band in which the radio operates	Always
Tuning Version	The default tuning data version	Always
Processor Version	The processor type and ROM version	Always
RF TEST	The radio has completed test mode.	Always
<p>* There is a KG display for as many algorithms as are installed in the radio. If there are no encryption algorithms installed, the radio displays "KGNONE" during the test-mode display sequence.</p>		

NOTE: All displays are temporary and will expire without any user intervention. If information is longer than the physical length of the radio's display, the information will wrap around to the next display.

3. Do one of the following:

- Press the **green button** on the control top to stop the displays and enter the RF test mode. The test mode menu option "1 CSQ" is displayed, indicating test frequency 1, Carrier Squelch mode. See Section 4.2.2: "RF Test Mode" on page 4-4.

OR

- Press the **top side button** to stop the displays and select the control top test mode. The test mode menu option "CH TEST" is displayed, indicating that you have selected the control top test mode. See Section 4.2.3: "Control Top Test Mode" on page 4-5.

NOTE: Each press of the **top side button** toggles between "CH TEST" and "RF TEST".

NOTE: Once your radio is in a particular test mode, you must turn off the radio and turn it back on again to access the other test mode.

4.2.2 RF Test Mode

When the SSE 5000 radio is operating in its normal environment, the radio's microcomputer controls the RF channel selection, transmitter key-up, and receiver muting, according to the customer codeplug configuration. However, when the unit is on the bench for testing, alignment, or repair, it must be removed from its normal environment using a special routine, called RF test mode.

While in RF test mode:

- Each press of the **one-dot side button** advances to the next test channel. (Refer to [Table 4-3](#).)
- Each press of the **two-dot side button** scrolls through and accesses the test environments shown in [Table 4-4](#).

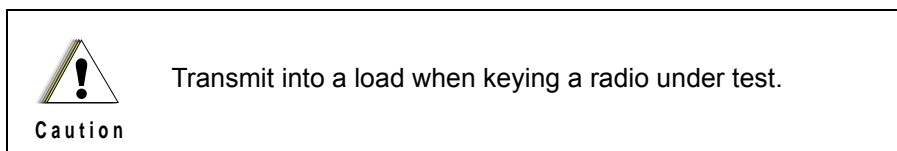


Table 4-3. Test Frequencies (MHz)

Test Channel	RX	TX
F1	450.0625	450.0125
F2	459.0625	459.0125
F3	469.0625	469.0125
F4	479.0625	479.0125
F5	488.0625	488.0125

Table 4-4. Test Environments

No. of Tones	Display	Description	Function
1	CSQ	Carrier Squelch	RX: unsquelch if carrier detected TX: mic audio
3	TPL	Tone Private-Line	RX: unsquelch if carrier and tone (192.8 Hz) detected TX: mic audio + tone (192.8 Hz)
11	AST	ASTRO	RX: none TX: 1200 Hz tone *
12	USQ	Carrier Unsquelch	RX: unsquelch always TX: mic audio

* All deviation values are based on deviation tuning of this mode.

4.2.3 Control Top Test Mode

This test mode is used to verify proper operation of all radio buttons and switches if a failure is suspected.

To perform the control top checks:

1. Press and hold the **green button** on the control top: the display is backlit, the radio icons are displayed, and the LED lights red.
2. Release the **green button**: "3/0" appears, which indicates that the green button is in the open position.

NOTE: Your radio is now in the control top test mode.

3. Press and hold the **green button** again: "3/1" appears, which indicates that the green button is in the closed position. Release the green button.
4. Rotate the **Channel Select knob**: "4/0" through "4/15" appear, which indicate that the select knob is in any of the channel positions from 1 through 16.
5. Cycle through the **Channel Bank Select (A/B/C) switch** settings: "67/0", "67/1" and "67/2" appear.
6. Rotate the **On/Off/Volume knob**: "2/0" through "2/255" appear. The display values may vary slightly at the upper and lower limits.
7. Press and hold the **top side button**: "96/1" appears; release: "96/0" appears.
8. Press and hold the **two-dot side button**: "97/1" appears; release: "97/0" appears.
9. Press and hold the **one-dot side button**: "98/1" appears; release: "98/0" appears.
10. Press the **PTT button**: "1/1" appears; release: "1/0" appears.

4.3 Receiver Performance Checks

The following table outlines the performance checks for the receiver.

Table 4-5. Receiver Performance Checks

Test Name	System Analyzer	Radio	Test Set	Comments
Reference Frequency	RF Control: Monitor Meter: RF Display Display: Bar Graphs Freq: Selected radio TX freq.	TEST MODE CSQ channel*	PTT to continuous (during the performance check)	UHF R2 (450–488 MHz): 2.5 ppm
Rated Audio	RF Control: Gen Output Level: -47 dBm Freq: Selected radio RX freq. Mod: 1 kHz tone @ 3 kHz dev. Meter: AC Volts	As above	PTT to OFF (center)	Set volume control to 3.74 Vrms
Distortion	As above, except Meter: Ext Dist.	As above	As above	Distortion < 3.0%
Sensitivity (SINAD)	As above, except Meter: SINAD	As above	As above	RF input to be < 0.35 μ V
Noise Squelch Threshold	Set as for rated audio check	Out of TEST MODE	As above	Set volume control to 3.74 Vrms. Set RF level to -130 dBm and raise until radio unsquelches. Unsquelch to occur at < 0.25 μ V. Preferred SINAD = 6-8 dB.

* See [Table 4-4 on page 4-4](#).

4.4 Transmitter Performance Checks

The following table outlines the performance checks for the transmitter.

Table 4-6. Transmitter Performance Checks

Test Name	System Analyzer	Radio	Test Set	Comments
Reference Frequency	RF Control: Monitor Meter: RF Display Display: Bar Graphs Freq: Selected radio TX freq.	TEST MODE CSQ channel*	PTT to continuous (during the performance check).	UHF R2 (450–488 MHz): 2.5 ppm
RF Power	As above	As above	As above	UHF R2 (450–488 MHz): 2–5 Watts
Voice Modulation (external)	As above. Set fixed 1 kHz audio level to 400 mV.	As above	As above	Deviation: (12.5 kHz) \geq 2.1 kHz, but \leq 2.5 kHz (25 kHz) \geq 4.1 kHz, but \leq 5.0 kHz
Voice Modulation (internal)	RF Control: Monitor Meter: RF Display Display: Bar Graphs Freq: Selected radio TX freq.	As above	Remove modulation input. PTT to OFF (center)	Press PTT button on radio. Say “four” loudly into the radio mic. Measure deviation: (12.5 kHz) \geq 2.1 kHz but \leq 2.5 kHz (25 kHz) \geq 4.1 kHz but \leq 5.0 kHz
PL Modulation (radios with clear mode, coded squelch operation only)	As above	Conventional coded squelch personality (clear mode operation) or TPL channel (test mode*)	PTT to continuous (during the performance check)	Deviation: (12.5 kHz) \geq 375 Hz but \leq 500 Hz (25 kHz) \geq 500 Hz but \leq 1000 Hz
Secure Modulation (radios with secure mode, talkaround operation only)	As above	Programmed conventional channel (secure mode operation) Load key into radio.	As above	Deviation: \geq 3.7 kHz but \leq 4.3 kHz

* See [Table 4-4 on page 4-4](#).

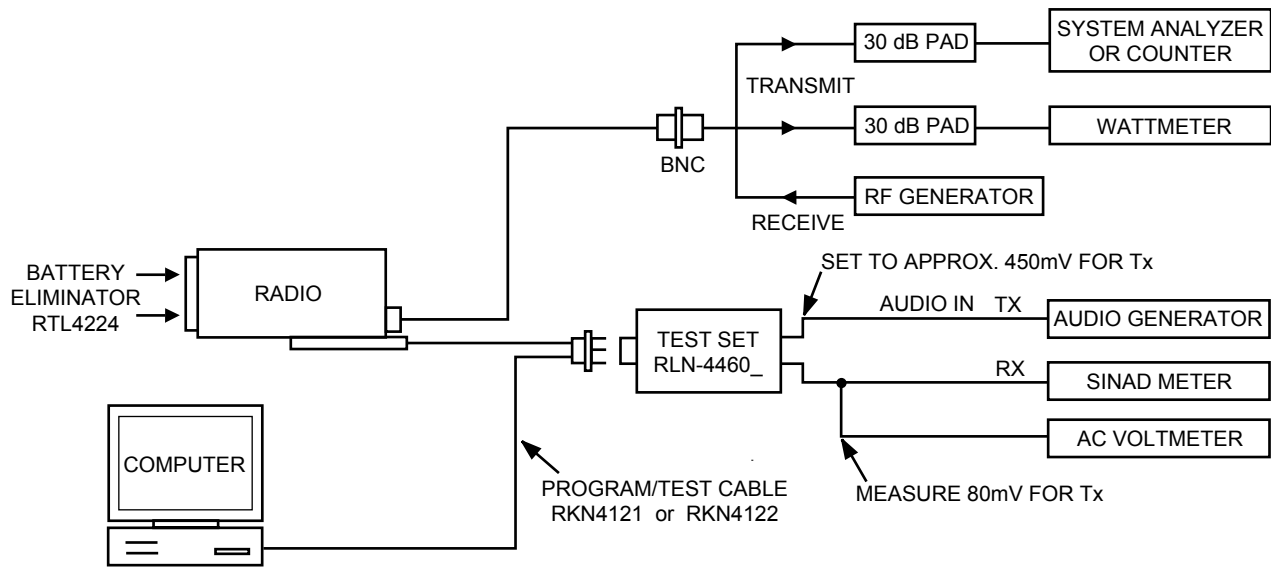
Notes

Chapter 5 Radio Alignment Procedures

This chapter describes radio alignment procedures for both the receiver and transmitter.

5.1 Radio Alignment Test Setup

A personal computer (PC) and tuner software (RVN4181) are required to align the radio. Refer to the Customer Programming Software (CPS) Installation Guide (Motorola publication part number 6881095C44) for setup procedures for the software, and to the on-line help in the CPS for complete field programming information. To perform the alignment procedures, the radio must be connected to the PC and to a universal test set. The radio alignment test setup is shown in [Figure 5-1](#).



MAEPF-27212-C


Figure 5-1. Radio Alignment Test Setup



Caution

These radio alignment procedures should only be attempted by qualified service personnel. Failure to perform alignment procedures properly may result in seriously degraded radio or system performance.

5.2 Reading the Radio

Select **Tuner** from the **START** menu. To read the radio, use the **File > Read Device** menu or click on .

5.3 Tuner Menu

Figure 5-2 illustrates how the alignment screens are organized. To access a screen, double-click on the desired screen name in the **Tuner** menu.

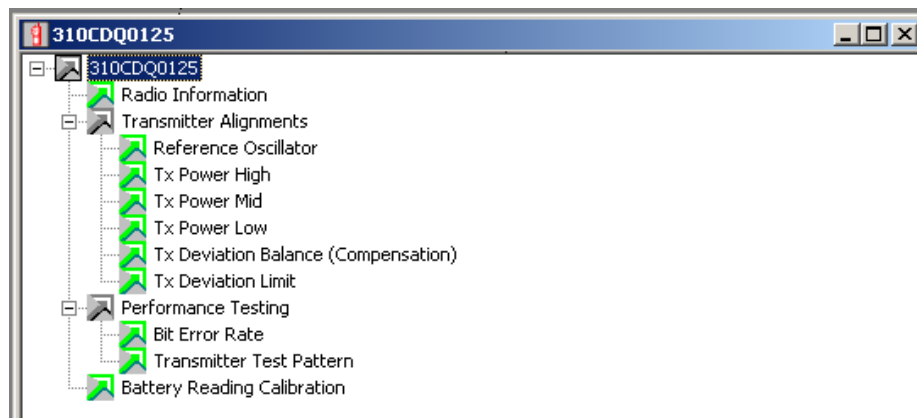


Figure 5-2. Tuner Software Main Menu

5.4 Radio Information

Figure 5-3 shows a typical Radio Information screen. This screen is informational only and cannot be directly changed.

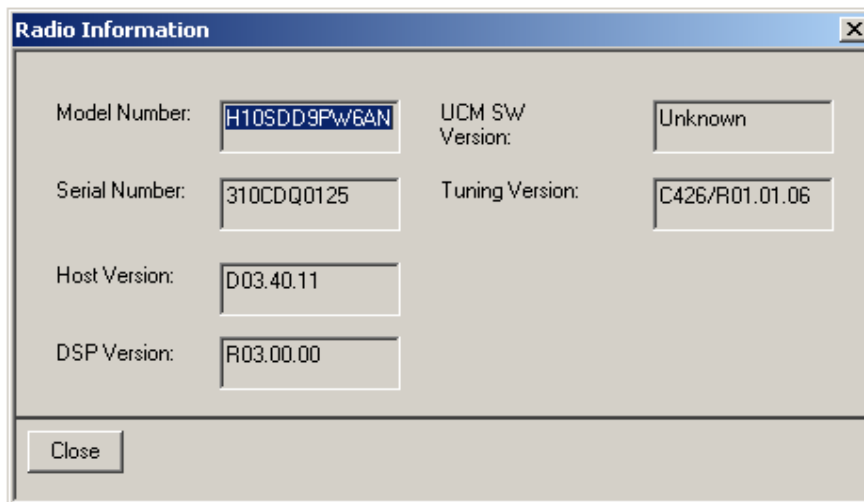



Figure 5-3. Radio Information Screen

5.5 Transmitter Alignments

5.5.1 Softpot

The alignment screens introduce the concept of the “softpot,” an analog **SOFT**ware-controlled **POT**entiometer used for adjusting all transceiver alignment controls.

 Caution	<p>DO NOT switch radios in the middle of any alignment procedure. Always left-click the Close button on the screen to return to the Main Menu screen before disconnecting the radio. Improper exits from the alignment screens might leave the radio in an improperly configured state and result in seriously degraded radio or system performance.</p>
---	---

Each alignment screen provides the ability to increase or decrease the softpot value by using a slider or the spin buttons in the New Softpot Value box, or by entering the new value from the keyboard directly into the box. The slider bar indicates the minimum and maximum values of the softpot, while the Radio Softpot Value indicates the recommended value; see [Figure 5-4](#).

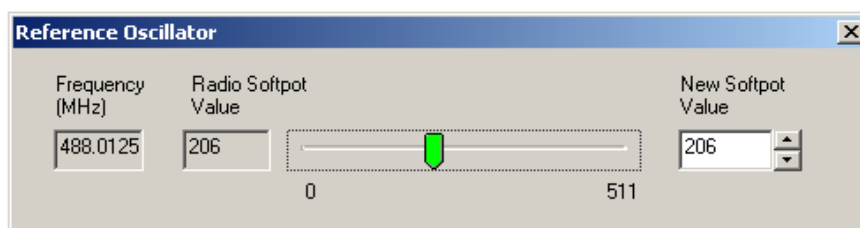



Figure 5-4. Typical Softpot Screen

Adjusting the softpot value sends information to the radio to increase (or decrease) the voltage in the corresponding circuit. For example, left-clicking the UP spin button in the New Softpot Value scroll box on the **Reference Oscillator** screen instructs the radio’s microcomputer to increase the voltage across a varactor in the reference oscillator, which increases the frequency.

In ALL cases, the softpot value is just a relative number corresponding to a digital-to-analog (D/A) generated voltage in the radio.

Perform the following procedures in the sequence indicated.

NOTE: Some of the following screens may vary depending upon the radio under test and the version of tuner software you are using. Refer to the software’s online help.

 Caution	<p>When keying the radio during a test, <i>a/ways</i> transmit into a dummy load.</p>
---	---

5.5.2 Reference Oscillator Alignment

Adjustment of the reference oscillator is critical for proper radio operation. Improper adjustment will result not only in poor operation, but also in a misaligned radio that will interfere with other users operating on adjacent channels. For this reason, the reference oscillator should be checked every time the radio is serviced, or once a year, whichever comes first. The frequency counter used for this procedure must have a stability of 0.1 ppm (or better).

NOTE: Reference oscillator alignment is required after replacing (or servicing) the transceiver board. To align the reference oscillator:

1. Select the **Reference Oscillator** alignment screen. See [Figure 5-5](#).

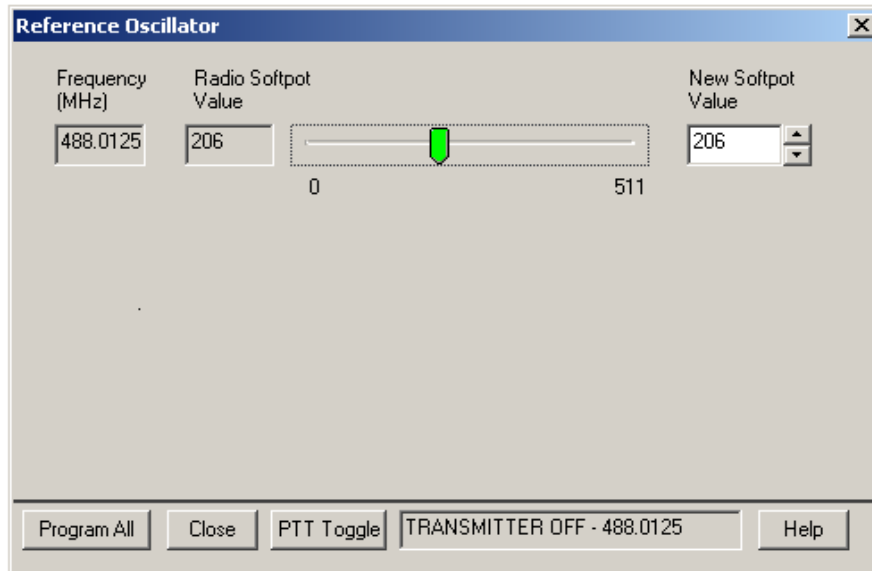


Figure 5-5. Reference Oscillator Alignment Screen

2. Left-click the **PTT Toggle** button on the screen to make the radio transmit. The screen indicates whether the radio is transmitting.
3. Measure the transmit RF frequency with your communications system analyzer.
4. Adjust the reference oscillator's softpot value until the measured value is as close as possible to the frequency shown on the screen. See [Table 5-1](#).

Table 5-1. Reference Oscillator Alignment

Band	Target
UHF R2 (450–488 MHz)	±100 Hz

5. Left-click the **Program All** button on the screen to dekey the radio and save the tuned values.
6. Left-click the **Close** button on the screen to return to the **Transmitter Alignments** menu.

5.5.3 Transmit Power Alignment

This alignment procedure adjusts the transmit power of the radio and must be performed for two different power levels (Low and High), at multiple frequencies for each power level, to allow for proper alignment across the entire RF band. (The mid-power level is available to be tuned, but it cannot be used.) The RF band is divided into frequency zones with a calibration point (value) in each zone.

NOTES:

- The same softpot attenuation value will result in **different** radio output power levels at different frequencies.
- All power measurements are to be made at the antenna port.
- Transmit Power alignment is required after replacing (or servicing) the transceiver board.

To align transmit power:

1. Select the **TX Power (Low or High)** alignment screen. The screen will indicate the transmit frequencies to be used. See [Figure 5-6](#) and [Figure 5-7](#).
2. Left-click the desired frequency field (starting with the highest frequency shown).
3. Left-click the **PTT Toggle** button on the screen to make the radio transmit. The screen indicates whether the radio is transmitting.
4. Measure the transmit power of the radio with your communications system analyzer.
5. Adjust the softpot value until the required power, as shown in [Table 5-2](#), is indicated on the communications system analyzer.

Table 5-2. Transmit Power Settings

Power Level	Transmit Power (Watts)
	UHF R2 (450–488 MHz)
Low	2.2–2.4
High	4.5–5.0

6. Repeat Steps 2 through 5 for all frequencies and all power levels.
7. Left-click the **Program All** button on the screen to dekey the radio and save the tuned values.
8. Left-click the **Close** button on the screen to return to the **Transmitter Alignments** menu.

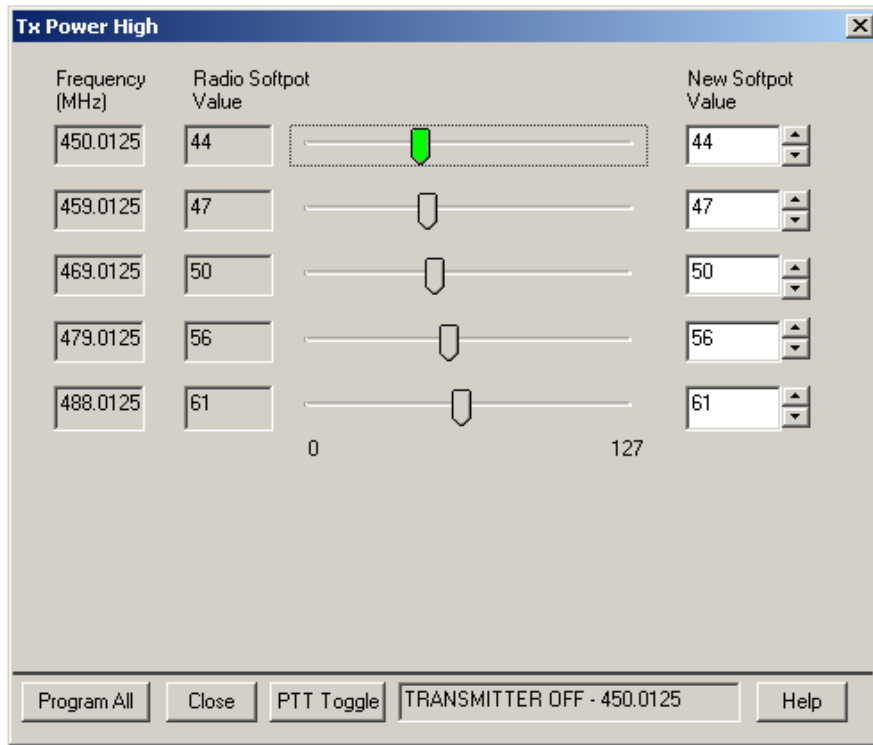


Figure 5-6. Transmit Power Alignment Screen (High Power)

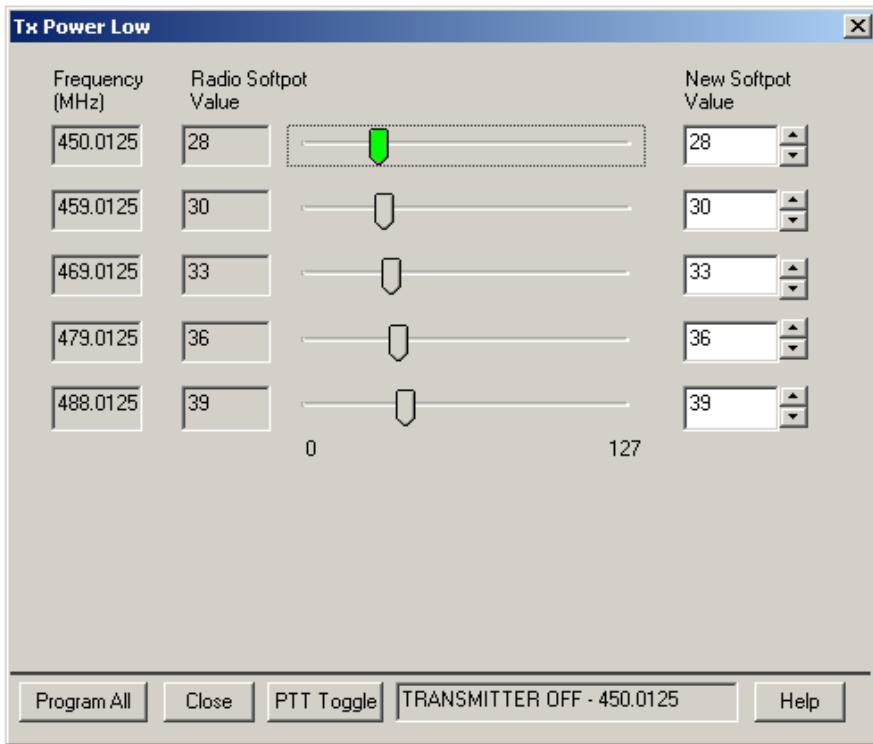


Figure 5-7. Transmit Power Alignment Screen (Low Power)

5.5.4 Transmit Deviation Balance Alignment

This alignment procedure balances the modulation contributions of the low- and high-frequency portions of a baseband signal. Proper alignment is critical to the operation of signalling schemes that have very low frequency components (for example, PL) and could result in distorted waveforms if improperly adjusted.

This procedure needs to be performed at multiple frequencies to allow for proper alignment across the entire RF band. The RF band is divided into frequency zones with a calibration point (value) in each zone.

NOTE: This alignment is required after replacing (or servicing) the VOCON board or the transceiver board.

To align transmit deviation balance:

1. Select the **TX Deviation Balance** alignment screen. The screen indicates the transmit frequencies to be used. See [Figure 5-8 on page 5-7](#).
2. Left-click the desired frequency field (starting with the highest frequency shown).
3. Left-click the **PTT Toggle** button on the screen to make the radio transmit. The screen indicates whether the radio is transmitting.
4. Left-click the **PTT Tone: Low** button.
5. Measure the transmitted signal deviation of the radio with your communications system analyzer.
6. Left-click the **PTT Tone: High** button.
7. Adjust the softpot value until the measured deviation, when using the High Tone, is as close as possible to that observed when using the Low Tone.

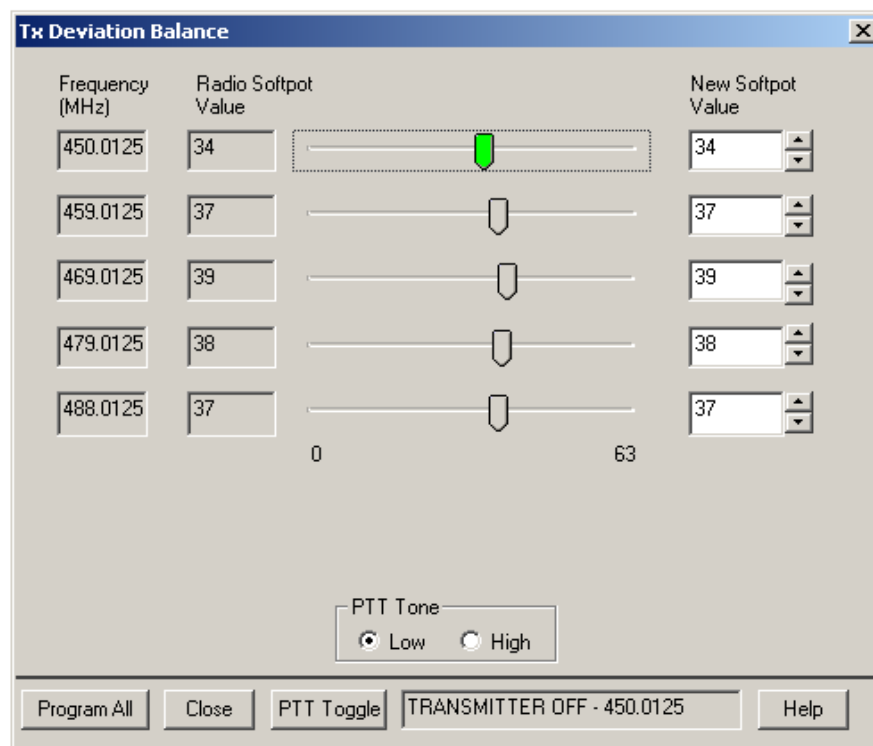


Figure 5-8. Transmit Deviation Balance Alignment Screen

8. Repeat Steps 2 through 7 for all frequencies.
9. Left-click the **Program All** button on the screen to dekey the radio and save the tuned values.
10. Left-click the **Close** button on the screen to return to the **Transmitter Alignments** menu.

5.5.5 Transmit Deviation Limit Alignment

This alignment procedure limits the modulation of a baseband signal. It is used for primary modulation limiting.

This procedure needs to be performed at multiple frequencies to allow for proper alignment across the entire RF band. The RF band is divided into frequency zones with a calibration point (value) in each zone.

NOTE: This alignment is required after replacing (or servicing) the VOCON board or the transceiver board.

To align the transmit deviation limit:

1. Select the **TX Deviation Limit** alignment screen. The screen indicates the transmit frequencies to be used. See [Figure 5-9](#).
2. Left-click the desired frequency field (starting with the highest frequency shown).
3. Left-click the **PTT Toggle** button on the screen to make the radio transmit. The screen indicates whether the radio is transmitting.
4. Measure the transmitted signal deviation of the radio with your communications system analyzer.
5. Adjust softpot value until the measured deviation is as close as possible to 2.83 kHz.

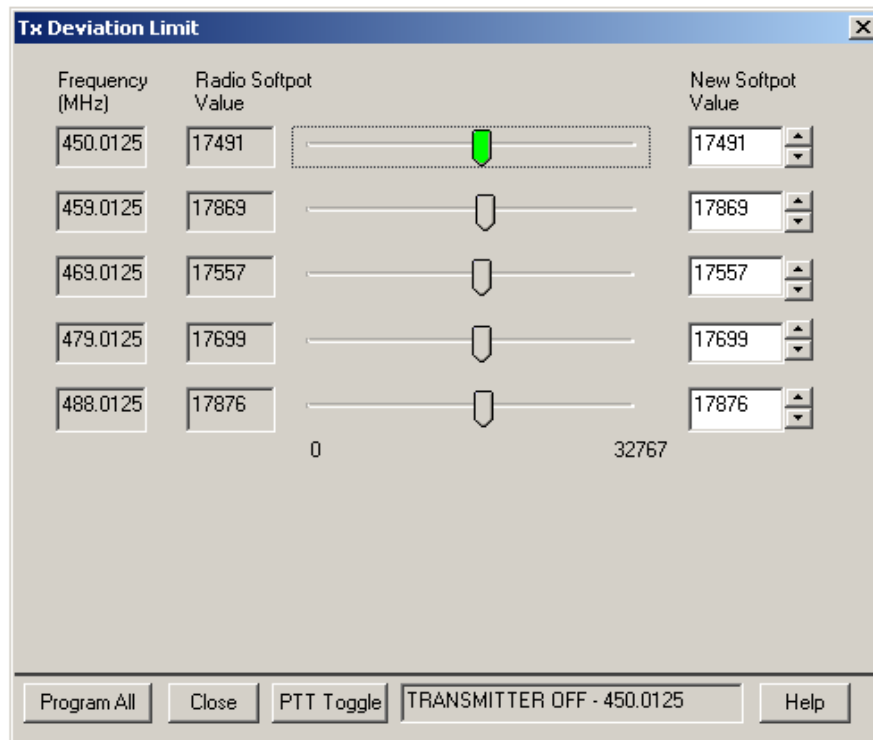


Figure 5-9. Transmit Deviation Limit Alignment Screen

6. Repeat the above process for all frequencies.
7. Left-click the **Program All** button on the screen to dekey the radio and save the tuned values.
8. Left-click the **Close** button on the screen to return to the **Transmitter Alignments** menu.

5.6 Performance Testing

5.6.1 Transmitter Test Pattern

The Transmitter Test Pattern test is used to transmit specific test patterns at a desired frequency so that the user can perform tests on the radio's transmitter (see [Figure 5-10](#)).

This screen contains the following fields:

- **Tx Frequency:**
This field selects the Transmit Frequency directly in MHz.
- **Channel Spacing:**
This field allows the user to select the desired transmit deviation in kHz.
- **Test Pattern Type:**
This field represents the type of test pattern which will be transmitted by the radio when **PTT TOGGLE** button is pressed.

NOTE: Channel Spacing and Test Pattern Type fields will be grayed out while radio is transmitting.

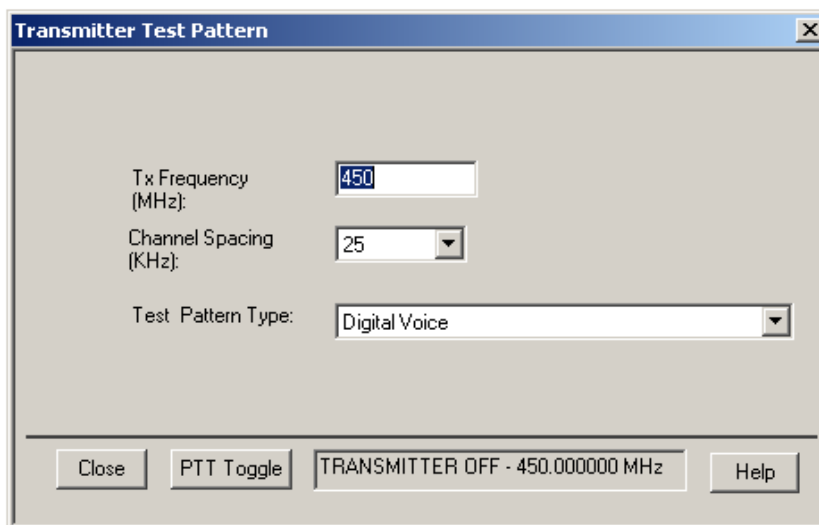


Figure 5-10. Transmitter Test Pattern Screen

5.6.2 Battery Reading Calibration

This alignment procedure adjusts the calibration factor used by the radio when determining the battery voltage. Correct calibration is required to ensure valid operation of the low battery indicator.

Before starting this procedure, make sure that the radio is *not* connected to the PC.

1. Remove the battery and use a regulated power supply to apply exactly 6.9 V to the battery contacts.
2. Connect the radio to the PC and read the radio (see [Section 5.2: "Reading the Radio" on page 5-2](#)).
3. Click on the "Auto Calibrate" button to make the radio determine a new calibration factor.

4. Click on the "Program All" button to save the new calibration factor.

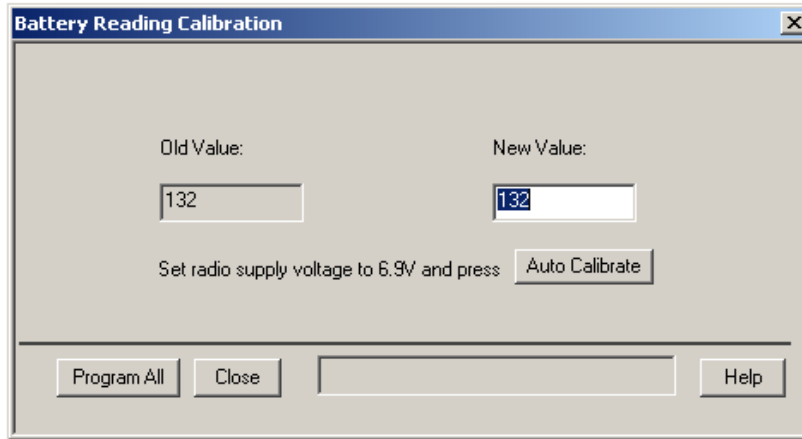


Figure 5-11. Battery Reading Calibration Screen

Chapter 6 Encryption

This chapter describes the encryption capability of the SSE 5000 radio.

6.1 Load an Encryption Key

To load an encryption key:

1. Refer to the key-variable loader (KVL) manual for equipment connections and setup.
2. Attach the KVL to the radio. The display shows "KEYLOAD." All other radio functions, except for power down, backlight, and volume, are locked out.
3. Refer to the KVL manual for how to load the encryption keys into the radio.
4. When the key is loaded successfully, you will hear:
 - On single-key radios—a short tone.
 - On multikey radios—an alternating tone.

6.2 Multikey Feature

This feature allows the radio to be equipped with multiple encryption keys. The encryption keys can be tied (strapped), on a one-per-channel basis. It can support up to three different encryption algorithms simultaneously (DES, DES-XL and DES-OFB).

Notes

Chapter 7 Disassembly/Reassembly Procedures

This chapter provides detailed procedures for disassembling/reassembling SSE 5000 radios and also includes preventive maintenance and handling precautions, which provide information vital to the successful operation and maintenance of your radio.

When performing the disassembly/reassembly procedures, refer to the exploded view ([Figure 7-1 on page 7-3](#)) and to the parts list ([Table 7-1 on page 7-4](#)). Items in parentheses () throughout this chapter refer to item numbers in the exploded view and its associated parts list.

This chapter also has procedures for removing and installing the SSE 5000 radio's standard accessories and changing the Volume and Channel Select knobs.

7.1 General Maintenance

In order to avoid operating outside the limits set by the FCC, we recommend that you align the SSE 5000 radio's reference oscillator every time the radio is taken apart, or once per year, whichever comes first. Periodic visual inspection and cleaning is also recommended.

7.1.1 Inspection

Check that the external surfaces of the radio are clean, and that all external controls and switches are functional. A detailed inspection of the interior electronic circuitry is not needed.

7.1.2 Cleaning

The following procedures describe the recommended cleaning agents and the methods to be used when cleaning the external surfaces of the radio. External surfaces include the housing assembly and battery case. These surfaces should be cleaned whenever a periodic visual inspection reveals the presence of smudges, grease, and/or grime.

The only recommended agent for cleaning the external radio surfaces is a 0.5% solution of a mild dishwashing detergent in water.



Caution

The effects of certain chemicals and their vapors can have harmful results on certain plastics. Aerosol sprays, tuner cleaners, and other chemicals should be avoided.

The detergent-water solution should be applied sparingly with a stiff, non-metallic, short-bristled brush to work all loose dirt away from the radio. A soft, absorbent, lintless cloth or tissue should be used to remove the solution and dry the radio. Make sure that no water remains entrapped near the connectors, cracks, or crevices.

7.2 Handling Precautions

Complementary metal-oxide semiconductor (CMOS) devices, and other high-technology devices, are used in this family of radios. While the attributes of these devices are many, their characteristics make them susceptible to damage by electrostatic discharge (ESD) or high-voltage charges. Damage can be latent, resulting in failures occurring weeks or months later. Therefore, special precautions must be taken to prevent device damage during disassembly, troubleshooting, and repair. Handling precautions are mandatory for this radio, and are especially important in low-humidity conditions. DO NOT attempt to disassemble the radio without observing the following handling precautions.

1. Eliminate static generators (plastics, Styrofoam, etc.) in the work area.
2. Remove nylon or double-knit polyester jackets, roll up long sleeves, and remove or tie back loose-hanging neckties.
3. Store and transport all static-sensitive devices in ESD-protective containers.
4. Disconnect all power from the unit before ESD-sensitive components are removed or inserted unless otherwise noted.
5. Use a static-safeguarded workstation, which can be accomplished through the use of an anti-static kit (Motorola part number 0180386A82). This kit includes a wrist strap, two ground cords, a static-control table mat and a static-control floor mat.



Caution

- The SSE 5000 radio casting has one vent port that allows for pressure equalization in the radio. Never poke this vent with any objects, such as needles, tweezers, or screwdrivers.
- The pressure equalization vent is located on the chassis, just below the battery contact. Never obstruct or cover the two slots with any object, including a label. Ensure that no oily substances come in contact with this vent.

If the radio battery contact area becomes wet, dry and clean the radio battery contacts before attaching a battery to the radio. Otherwise, the water could short-circuit the radio.

If the radio has come into contact with water, shake the radio briskly so that any water that is trapped inside the speaker grille and microphone port can be removed. Otherwise, the water will decrease the audio quality of the radio.



Caution

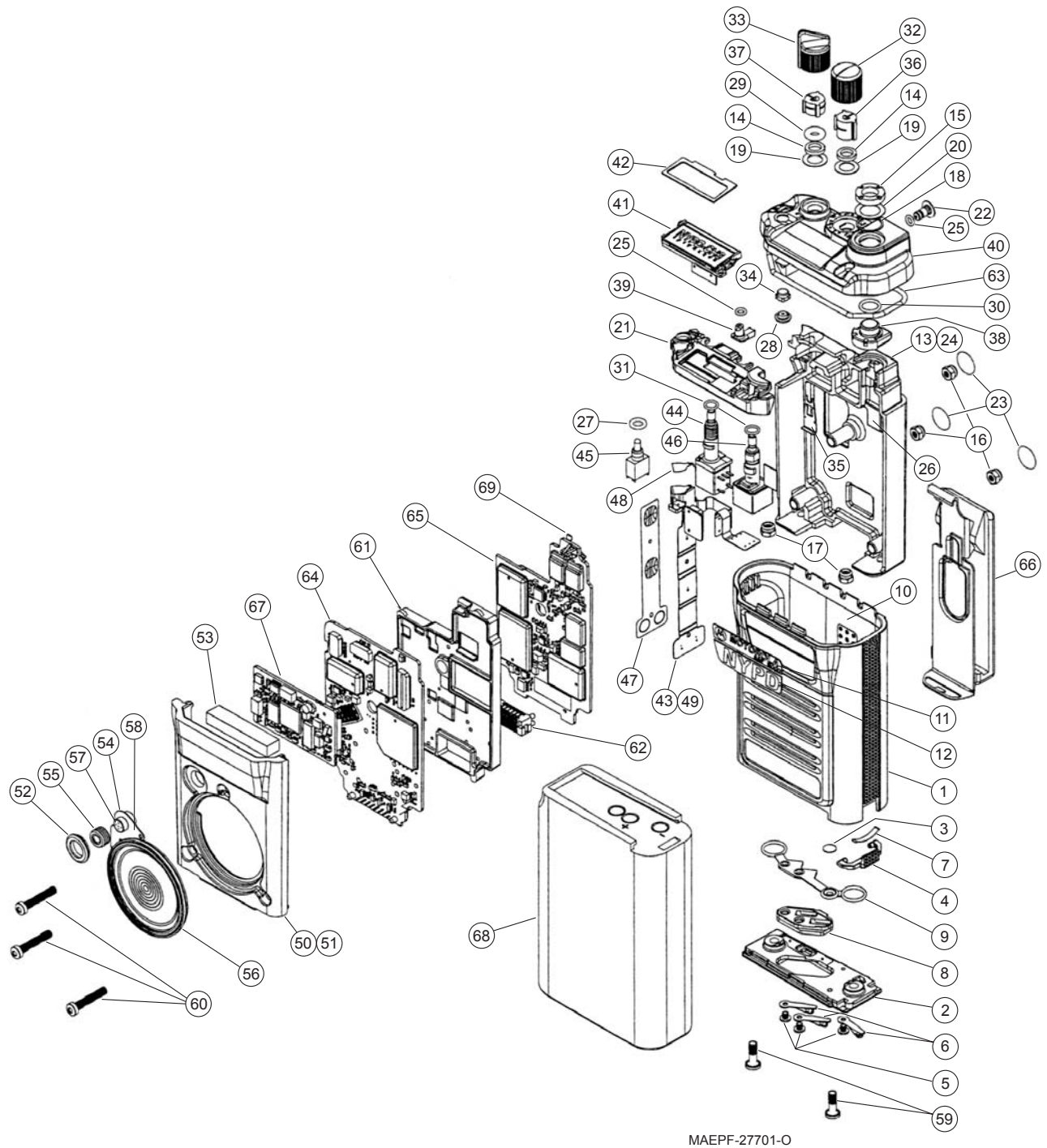
To maintain the integrity of the RF PA, **never heat it above 210°C** while performing repair or rework procedures. To prevent overheating the RF PA during rework, use a ChipMaster (R1319 or R1321) top-side pre-heat set point of 215°C and a Dragon (R1427) bottom-side pre-heat set point of 204°C for 1 minute before and throughout top-side heat application, assuming that the RF PA is removed from the applied heat 10 seconds after reflow occurs. (The RF PA temperature does not reach the ChipMaster's internal set point temperature). All other parts on the transceiver board can be reworked with ChipMaster top-side heat alone.

7.3 SSE 5000 Exploded View

This section contains the SSE 5000 radio exploded view and parts list.

NOTES:

- Numbers in parentheses () refer to item numbers in [Figure 7-1](#) and [Table 7-1](#) on page 7-4.



MAEPF-27701-O

Figure 7-1. SSE 5000 Exploded View

Table 7-1. SSE 5000 Exploded View Parts List

Item	Part Number	Description	Qty
1	NNTN4467_	KIT, HOUSING (includes items 2–12)	1
2	6485388E02	ASSEMBLY, BASEPLATE	1
3	3205472M02	SEAL, PORT	1
4	5585389E01	LATCH, BATTERY	1
5	0305731J22	SCREWS, CONTACT	3
6	3905253X01	CONTACTS, POWER	3
7	4105775Q01	LATCH, SPRING	1
8	1485390E01	INSULATOR, BASEPLATE CONTACT	1
9	3285391E01	SEAL, BASEPLATE BUSHING	1
10	1405182M03	INSULATOR, UNIVERSAL CONNECTOR	1
11	3385436E01	LABEL, FRONT (MOTOROLA)	1
12	3385436E02	LABEL, FRONT (NYPD)	1
13	NNTN4825_	KIT, BACK CHASSIS (includes items 14–49)	1
14	0205163Q02	NUTS, SPANNER, CHANNEL/VOLUME POT	2
15	0205591R01	NUT, ANTENNA BUSHING	1
16	0285393E01	NUTS, HEX, TOP-INSERT	5
17	4285643F01	RETAINERS, HEX, LOCK NUT	2
18	0400139731	LOCKWASHER, INTERNAL TOOTH	1
19	0402838X01	WASHERS, WAVE CHANNEL/VOLUME POT	2
20	0405659W01	WASHER, ANTENNA SWITCH	1
21	0785411E02	BRACKET, METALIZED LCD/RF SHIELD WITH INSULATOR	1
22	0985412E01	CONNECTOR, RF (Bullseye)	1
23	1185815E01	ADHESIVE, CLEAR (NUT RETAINERS)	3
24	2785302E01	CHASSIS, BACK	1
25	3205082E13	O-RINGS, TX LIGHTPIPE and RF BULLSEYE	2
26	3262737D01	PAD, THERMAL	1
27	3285425E01	SEAL, TOGGLE	1
28	3285730E01	SEAL ACTUATOR, DISPLAY	1
29	3205082E86	O-RING, VOLUME TORQUE	1
30	3285796E01	O-RING, ANTENNA BUSHING	1
31	3285797E01	O-RINGS, CHANNEL/VOLUME POT	2
32	3605649S02	KNOB, CHANNEL SELECT	1
33	3605862T01	KNOB, VOLUME	1
34	3885413E01	BUTTON, DISPLAY	1
35	4285416E01	CLIP, RF GROUND, PLATED	1
36	4305141R02	INSERT, CHANNEL SELECT KNOB	1
37	4305648S01	INSERT, VOLUME KNOB	1

Table 7-1. SSE 5000 Exploded View Parts List (Continued)

Item	Part Number	Description	Qty
38	4385294E01	BUSHING, ANTENNA/INSULATOR	1
39	6185418E01	LIGHTPIPE, TX	1
40	6485298E02	SUB-ASSEMBLY, CONTROL TOP	1
41	7285419E01	MODULE, LCD	1
42	7585729E01	PAD, DUST, DISPLAY	1
43	8485687E01	ASSEMBLY, CONTROL FLEX (includes items 44–49)	1
44	1885300E01	SWITCH, VOLUME POT	1
45	4005572W04	SWITCH, 3-POSITION TOGGLE	1
46	4085299E01	SWITCH, CHANNEL SELECT	1
47	4085414E01	SWITCH ARRAY, SIDE BUTTONS	1
48	4085415E01	SWITCH, TACTILE DOME, DISPLAY	1
49	8485174F01	FLEX, CONTROL	1
50	NNTN4826_	KIT, FRONT CHASSIS (includes items 51–58)	1
51	2785301E01	CHASSIS, FRONT	1
52	4385778E01	COVER, MIC	1
53	7505316J12	PAD, 20-PIN RETAINER	1
54	8485791E01	ASSEMBLY, SPEAKER MIC FLEX (includes items 55–58)	1
55	1480577C01	BOOT, MIC	1
56	5085927E01	SPEAKER	1
57	5086347A02	MIC	1
58	8485423E01	FLEX, SPEAKER MIC	1
59	0385392E01	BOLT, SELF-SEALING STAR PAN	2
60	0385913E01	BOLTS, CHASSIS	3
61	2685303E01	SHIELD, MAIN (PLATED PLASTIC)	1
62	2885866A01	CONNECTOR, COMPRESSION, 26-PIN BOARD-TO-BOARD	1
63	3285196F01	SEAL, MAIN	1
64	NCN6186_	BOARD, VOCON	1
65	NUE7337_	BOARD, TRANSCEIVER	1
66	NNTN4709_	KIT, BELT CLIP	1
67	NNTN4006_	MODULE, ENCRYPTION	1
68	—	BATTERY (see Section A.2: “Batteries” on page A-1 for part numbers)	1
69	3985586E01	CLIP, RF CONTACT	1

7.4 Disassembly/Reassembly Procedures for Accessories

7.4.1 Antenna

This section explains how to attach and remove the antenna.

7.4.1.1 Attach the Antenna

With the radio turned off, twist the antenna clockwise onto the connector on the top of the radio.

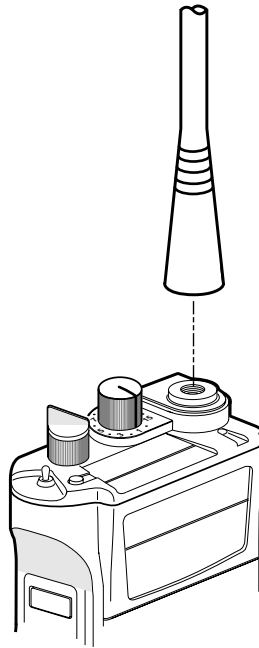


Figure 7-2. Attaching/Removing the Antenna

NOTE: If you are using a public safety mic (PSM), the antenna for the PSM must be attached to the PSM. Refer to the accessory guide included with the PSM.

7.4.1.2 Remove the Antenna

With the radio turned off, twist the antenna counter-clockwise to remove it from the radio.

7.4.2 Battery

This section explains how to properly attach and remove the battery.



To avoid a possible explosion:

- **DO NOT** charge, remove, or attach the battery in an area labeled "hazardous atmosphere."
- **DO NOT** discard batteries in a fire.

**Caution**

If the radio is programmed for volatile-key retention, encryption keys will be retained for approximately 30 seconds after battery removal.

NOTE: The Motorola-approved battery shipped with the SSE 5000 radio is uncharged. Prior to using a new battery, charge it for a minimum of 16 hours to ensure optimum capacity and performance.

7.4.2.1 Attach the Battery

1. With the radio turned off, align the baseplate on the bottom of the radio with the groove on the top of the battery.
2. Slide the battery toward the latch until it clicks into place.

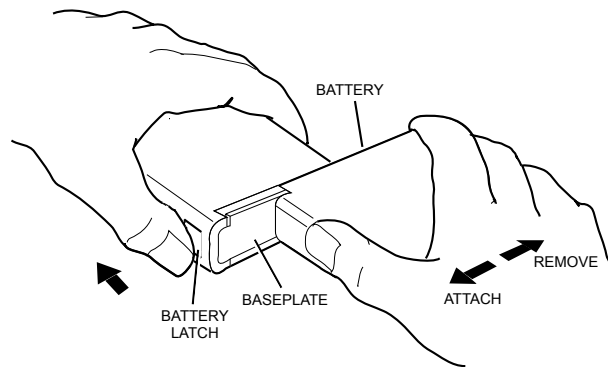


Figure 7-3. Attaching/Removing the Battery

7.4.2.2 Remove the Battery

With the radio turned off, slide the battery latch up and hold it while sliding the battery away from the latch.

7.4.3 Belt Clip

This section explains how to attach and remove the belt clip.

7.4.3.1 Attach the Belt Clip

1. With the battery removed, remove the baseplate assembly from the housing assembly (complete up to Step 5. in [Section 7.6.4: "Disassemble the Housing Baseplate" on page 7-14](#)).
2. Hook the top of the belt clip into the slot near the top of the radio in the back.
3. Press the bottom of the belt clip into the slot near the base of the radio until it is pressed firmly into place.

4. Re-install the baseplate assembly in the housing assembly (complete up to Step 5. in [Section 7.7.4: "Reassemble the Housing Baseplate" on page 7-17](#)).

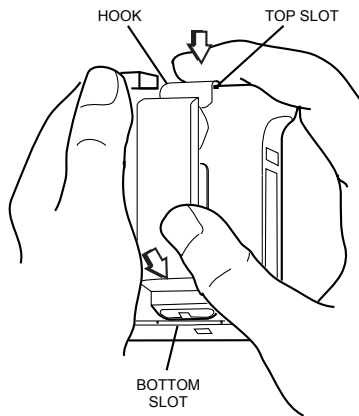


Figure 7-4. Attaching the Belt Clip

7.4.3.2 Remove the Belt Clip

1. With the battery removed, remove the baseplate assembly from the housing assembly (complete up to Step 5. in [Section 7.6.4: "Disassemble the Housing Baseplate" on page 7-14](#)).
2. Lift the belt clip up and away from the radio.
3. Re-install the baseplate assembly in the housing assembly (complete up to Step 5. in [Section 7.7.4: "Reassemble the Housing Baseplate" on page 7-17](#)).

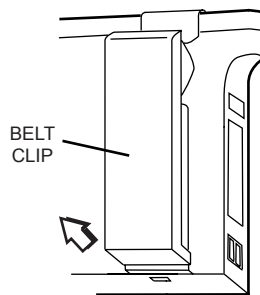


Figure 7-5. Removing the Belt Clip

7.4.4 Carry Case

This section explains how to assemble the carry case, belt loop and T-strap.

1. Slide the belt loop onto your belt.
2. Snap the two horizontal snaps of the T-strap onto the back of the carry case so that the cords lead upwards.
3. Insert the radio snugly into the carry case.
4. Pull the cords of the T-strap over the top of the radio, on either side of the Channel Select knob.
5. Snap the other end of the T-strap onto the front of the carry case.
6. Turn the carry case, with the radio strapped in, upside down.
7. Align the knob on the back of the carry case with the open end of the groove on the front of the belt loop.
8. Slide the carry case all the way down into the groove.
9. Turn the carry case and radio right side up.

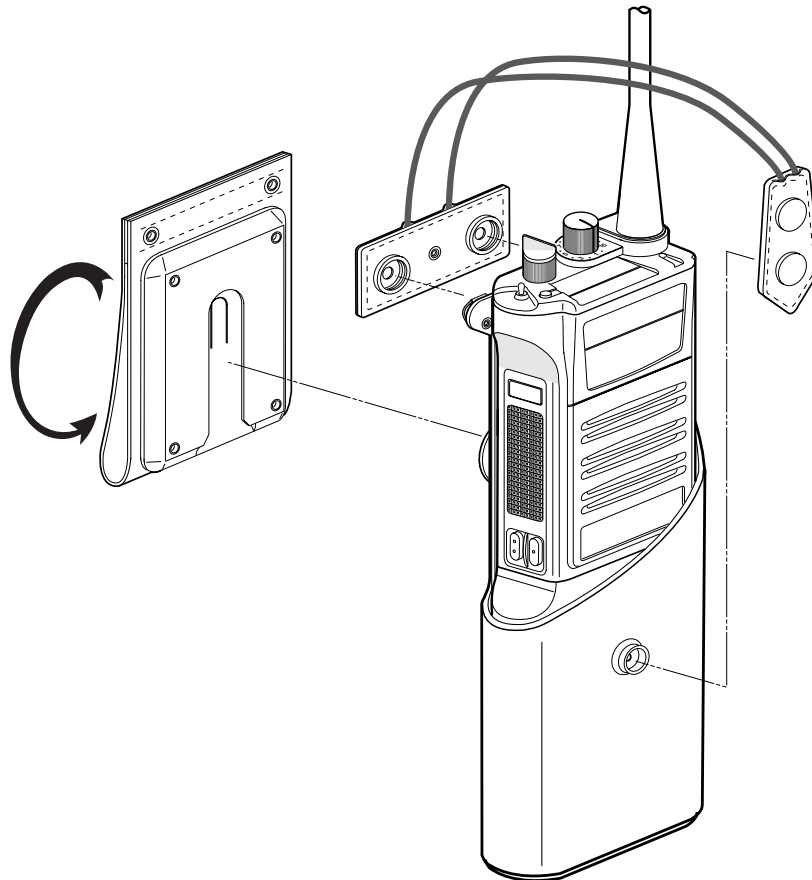
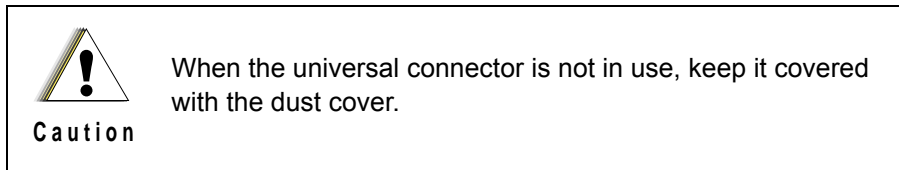


Figure 7-6. Assembling the Carry Case

7.4.5 Universal Connector Dust Cover

This section explains how to remove and attach the dust cover for the universal connector.



7.4.5.1 Remove the Universal Connector Dust Cover

1. Use a Phillips-head screwdriver to unscrew the screw at the top of the dust cover.
2. Pull the dust cover away and up until it is separated from the radio.

7.4.5.2 Attach the Universal Connector Dust Cover

1. Hook the bottom of the dust cover into the slot on the left rear of the radio, just below the accessory connector.
2. Align the screw on the dust cover with the hole on the radio, behind the antenna connector.
3. Use a Phillips-head screwdriver to screw the dust cover firmly into place.

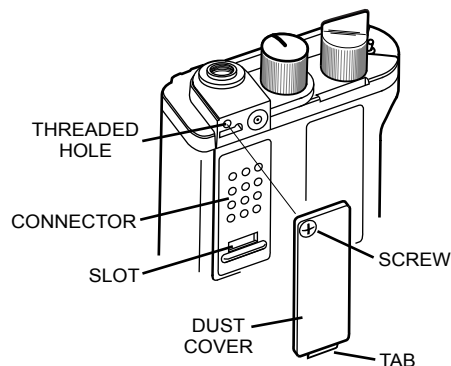


Figure 7-7. Attaching the Universal Connector Dust Cover

7.5 Disassembly/Reassembly Procedures for Radio Knobs

NOTE: Numbers in parentheses () refer to item numbers in [Figure 7-1 on page 7-3](#) and [Table 7-1 on page 7-4](#).

Table 7-2. Tools Used for Disassembly/Reassembly

Tool	Comment	Part No.
ROTO-TORQ Tool	Adjustable torque driver	RSX4043_
Phillips Head Star Bit	Used for attaching/detaching power contact screws.	6680321B79
Channel and Volume Switch Spanner Nut Bit	Used for attaching/detaching volume control and channel select switch spanner nuts.	6680370B88
Antenna Spanner Nut Bit	Used for attaching/detaching antenna spanner nuts.	6680371B34
T-10 Torx Bit	Used for attaching/detaching radio bolts.	6680387A74

7.5.1 Channel Select Knob

This section explains how to remove and install the Channel Select knob.

NOTES:

- Remove the battery from the radio before removing or installing the Channel Select knob.
- The Channel Select knob is a two-part kit, consisting of a knob and an insert. Once an insert is removed, it cannot be used again. Therefore, remove an insert *only* if the channel select switch must be replaced, or if the control top must be removed from the chassis.
- When the channel select insert must be removed, a new one *must* be used for reassembly.

7.5.1.1 Remove the Channel Select Knob

1. Hold the radio so that the top of the radio faces upward, and the front of the radio faces you.
2. Grasp the Channel Select knob (32) and pull it upward, while rocking the knob back and forth, until it is free from the Channel Select knob retainer insert (36), or the insert is free from the shaft.
3. To remove the knob retainer insert (36), place the tip of a thin-bladed screwdriver into the slot of the insert, and pry the insert open by twisting the screwdriver. This will allow you to easily remove the insert from the channel select switch shaft. **Discard the removed insert.**

7.5.1.2 Install the Channel Select Knob

1. Hold the radio so that the top of the radio faces upward, and the front of the radio faces you.
2. Place a new Channel Select knob retainer insert (36) on the channel select shaft, orienting the "TOP" marking on the insert upwards and aligning the insert's D-shaped hole with the D-shaped shaft. Press downward firmly on the insert until the top of it is flush with the top of the channel select shaft.
3. Place the Channel Select knob (32) on the retainer insert (36), aligning the three ribs of the insert to the corresponding slots on the inside of the knob. Press downward firmly on the knob until it seats securely in place.

7.5.2 Volume Knob

This section explains how to remove and install the Volume knob.

NOTES:

- Remove the battery from the radio before removing or installing the Volume knob.
- The Volume knob is a two-part kit, consisting of a knob and an insert. Once an insert is removed, it cannot be used again. Therefore, remove an insert *only* if the volume control must be replaced, or if the control top must be removed from the chassis.
- When the volume insert must be removed, a new one *must* be used for reassembly.

7.5.2.1 Remove the Volume Knob

1. Turn the Volume knob (33) to the off position.
2. Hold the radio so that the top of the radio faces upward, and the front of the radio faces you.
3. Grasp the Volume knob (33) and pull it upward, while pushing it toward the back of the radio, until it is free from the Volume knob retainer insert (37), or the insert is free from the shaft.
4. To remove the knob retainer insert (37), place the tip of a thin-bladed screwdriver into the slot of the insert, and pry the insert open by twisting the screwdriver. This will allow you to easily remove the insert from the volume control shaft. **Discard the removed insert.**

5. Using needle-nosed pliers or some other pointed instrument, remove the volume torque o-ring (29).

7.5.2.2 Install the Volume Knob

1. Place the volume torque o-ring (29) over the volume control shaft.
2. Hold the radio so that the top of the radio faces upward, and the front of the radio faces you.
3. Place a new Volume knob retainer insert (37) on the volume control shaft, orienting the "TOP" marking on the insert upwards and aligning the insert's D-shaped hole with the D-shaped shaft. Press downward firmly on the insert until the top of it is flush with the top of the volume control shaft.
4. Place the Volume knob (33) on the retainer insert (37), aligning the three ribs of the insert to the corresponding slots on the inside of the knob. Press downward firmly on the knob until it seats securely in place.

7.6 Disassembly Procedures for SSE 5000 Radio

This section contains instructions for disassembling the radio.

NOTE: Numbers in parentheses () refer to item numbers in [Figure 7-1 on page 7-3](#) and [Table 7-1 on page 7-4](#).

7.6.1 Separate the Chassis and Housing Assemblies

1. Turn the radio off by rotating the On/Off/Volume knob (33) fully counter-clockwise until you hear a click.
2. Remove the battery, the universal connector dust cover or any accessory (other than the antenna) connected to the radio.

NOTE: It is not necessary to remove the Volume knob (33) and insert (37) or Channel Select knob (32) and insert (36) to service the chassis assembly (13). However, if any top control is suspected, then the knobs and inserts should be removed prior to removing the chassis assembly (13) from the housing assembly (1). See [Section 7.5.1.1: "Remove the Channel Select Knob" on page 7-11](#) and [Section 7.5.2.1: "Remove the Volume Knob" on page 7-11](#).

3. Remove the two self-sealing bolts (59) on the bottom of the radio using a ROTO-TORQ adjustable torque screwdriver with a T-10 TORX bit (see [Table 7-2 on page 7-10](#) for part numbers).

NOTE: Inspect the seals of the bolts after removal. If the seals are damaged, discard both the seals and the bolts and replace with new self-sealing bolts.

4. Remove the chassis (13) from the radio housing (1) by grasping the antenna and gently pulling upward to separate the assembly from the housing. Do not depress the PTT button during removal.

NOTE: Inspect the universal connector insulator (10), located inside the housing on the back face, for damage. If it is damaged, replace the insulator, taking care to ensure that all contacts facing the inside of the radio are covered and keeping the insulator away from the main o-ring (63) sealing area.

7.6.2 Disassemble the Chassis Assembly

NOTE: If the radio is equipped with hardware encryption, the encryption board (67) is attached to the front side of the VOCON board (64) via a 40-pin connector.

1. Put the housing assembly (1) aside.
2. Remove the main seal/toggle support (63) from around the chassis assembly (13).
NOTE: Inspect the main-seal/toggle support for damage. If it is damaged, replace with a new seal prior to reassembly.
3. With the front of the radio facing upward, remove the three chassis bolts (60) from the front chassis (50) using a ROTO-TORQ adjustable torque screwdriver with a T-10 TORX bit (see [Table 7-2 on page 7-10](#) for part numbers).
4. Remove the front chassis assembly (50).
5. Disconnect the encryption board (67), if present, by separating the 40-pin connector from the VOCON board (64).
6. Disconnect the 20-pin control flex connector and the 20-pin display flex connector from the VOCON board (64).
7. Remove the VOCON board (64) from the back chassis (13) by lifting the board from the bottom and pulling the board out and away from the assembly.
8. Lift out the 26-pin compression connector (62).
9. Remove the main shield (61) and transceiver board (65) from the back chassis (13) in unison by lifting both parts from the bottom of the radio until they clear the center boss of the back chassis. Once clear of the center boss, they can be pulled out and away from the assembly.
NOTE: Inspect the back chassis (13) to make sure that the thermal pad (26) is attached to the chassis. If the pad is attached to the transceiver board, remove it from the board, discard it, and attach a new thermal pad to the chassis heat sink island.
10. Separate the main shield (61) from the transceiver board (65).

NOTE: Inspect the conductive gasket of the main shield for damage. If the conductive gasket seal is damaged, discard the main shield and replace it with a new one.

NOTE: The hex lock nuts (16), which hold the housing to the chassis assembly (13), are located in recesses at the bottom of the back chassis. These nuts are retained by the hex lock nut retainers (17). If the hex lock nuts need to be replaced, they can be removed with tweezers.

7.6.3 Disassemble the Control Top

1. Referring to [Section 7.5.1.1: "Remove the Channel Select Knob" on page 7-11](#) and [Section 7.5.2.1: "Remove the Volume Knob" on page 7-11](#), remove the Channel Select knob (32), channel select insert (36), Volume control knob (33), volume control insert (37), and volume torque o-ring (29).
2. Remove the volume control and channel select spanner nuts (14) using a ROTO-TORQ adjustable torque screwdriver with the volume/channel switch spanner nut bit (see [Table 7-2 on page 7-10](#) for part numbers).
3. Remove the volume control and channel select wave washers (19).
4. Remove the antenna spanner nut (15) using a ROTO-TORQ adjustable torque screwdriver with the antenna spanner nut bit (see [Table 7-2 on page 7-10](#) for part numbers).
5. Remove the antenna star lock washer (18) and the antenna wave washer (20).
6. Remove the external RF retainer clip (35) by sliding the clip towards the bottom of the radio, in a direction parallel to the back face of the radio, until the clip disengages from the external RF contact (22) and the clip is free of the back chassis (13).
7. Remove the external RF contact (22) from the control top (40) by gently pushing the contact from the inside of the radio until it is free from the back of the radio.

NOTE: Inspect the RF contact seal (25) for damage. If it is damaged, discard it and replace with a new seal.

8. Remove the control top (40) from the back chassis (13) by pulling the control top away from the back chassis.
9. Remove the LCD module (41) by lifting the module away from the LCD module bracket (21), while feeding the 20-pin LCD module flex connector through the hole in the bracket. Use care not to damage the flex of the LCD module during removal.
10. Remove the TX/RX lightpipe (39) from the LCD module bracket (21) by lifting the lightpipe from the bracket.

NOTE: Inspect the lightpipe seal (25) for damage. If it is damaged, discard it and replace with a new seal.

11. Remove the display button (34) and seal (28) from the control top (40) by pushing the display button from the outside surface of the control top until the seal and button fall free from the control top.

NOTE: Inspect the display button seal (28) for damage. If it is damaged, discard it and replace with a new seal.

12. Remove the antenna bushing (38) from the back chassis (13) by lifting the bushing from the back chassis.

NOTE: Inspect the antenna bushing o-ring (30) for damage. If it is damaged, discard it and replace with a new seal.

7.6.4 Disassemble the Housing Baseplate

NOTE: All repairs to the baseplate assembly can, and should, be made with the radio chassis inside the radio.

1. If not done already, remove the two self-sealing bolts (59) on the bottom of the radio using a ROTO-TORQ adjustable torque screwdriver with a T-10 TORX bit (see [Table 7-2 on page 7-10](#) for part numbers).

NOTE: Inspect the seals of the bolts after removal. If the seals are damaged, discard both the seals and the bolts and replace with new self-sealing bolts.

2. Remove the three radio power contact screws (5) using a ROTO-TORQ adjustable torque screwdriver with a Phillips star bit (see [Table 7-2 on page 7-10](#) for part numbers).
3. Remove the three power contacts (6).
4. Remove the baseplate contact insulator (8).
5. Remove the baseplate (2).
6. Remove the battery latch (4).
7. Remove the latch spring (7).
8. Remove the baseplate seal (9).

NOTE: Inspect the baseplate seal for damage. If it is damaged, discard it and replace with a new seal.

9. Inspect the radio port seal (3).

NOTE: If the port seal is punctured or damaged, it must be replaced with a new port seal. If the port seal needs to be replaced, it can be peeled off of the housing. All residual adhesive on the housing must be removed before replacing the port seal.

7.7 Reassembly Procedures for SSE 5000 Radio

This section contains instructions for reassembling the radio.

NOTE: Numbers in parentheses () refer to item numbers in [Figure 7-1 on page 7-3](#) and [Table 7-1 on page 7-4](#).

7.7.1 Reassemble the Control Top

1. Install the antenna bushing (38) by sliding it into the antenna bushing recess in the back chassis (13). Ensure that the antenna bushing o-ring (30) is in place before proceeding.
2. Install the lightpipe (39) into the LCD bracket (21). Ensure that the lightpipe o-ring (25) is in place before proceeding.
3. Install the display button (34) and seal (28) into the control top (40). Ensure that the seal is pressed firmly in place and is fully retained in the recess of the control top.
4. Install the LCD module (41) into the LCD bracket (21), orienting the display such that the locating hole of the LCD support frame aligns with the locating pin of the LCD bracket, while feeding the 20-pin flex connector of the LCD through the hole in the LCD bracket.

NOTE: If the glass surface of the LCD display requires cleaning, gently clean the glass surface using a soft, lint-free cloth.

NOTE: Before placing the control top (40) onto the back chassis (13), inspect the channel select and volume control seals (31) and toggle switch seal (27) for damage. If any are damaged, discard and replace with new seal(s).

5. Install the control top (40) onto the back chassis (13), aligning the controls and the antenna bushing (38) of the radio through their respective holes in the control top.
6. Install the external RF contact (22) into the back of the control top (40). Push the RF contact fully into place until it is flush with the back of the control top.
7. While holding the RF contact (22) flush to the back of the control top (40) and ensuring the short "L" leg of the retainer clip (35) is pointing towards the front of the radio, install the external RF retainer clip by sliding it towards the top of the radio, in a direction parallel to the back face of the radio, until the clip engages and "snaps" onto the external RF contact (22).
8. Place the antenna wave washer (20) and then the antenna star lock washer (18) over the antenna bushing (38).
9. Place the antenna spanner nut (15) onto the antenna bushing (38). Using a ROTO-TORQ adjustable torque screwdriver with the antenna spanner nut bit (see [Table 7-2 on page 7-10](#) for part numbers), tighten the antenna spanner nut to 20 in-lbs.
10. Place the volume control and channel select wave washers (19) over the volume control and channel select recesses.
11. Place the volume control and channel select spanner nuts (14) over the volume control and channel select wave washers (19). Using a ROTO-TORQ adjustable torque screwdriver with the volume/channel switch spanner nut bit (see [Table 7-2 on page 7-10](#) for part numbers), tighten the volume control and channel select spanner nuts to 8 in-lbs.
12. Referring to [Section 7.5.1.1: "Remove the Channel Select Knob" on page 7-11](#) and [Section 7.5.2.1: "Remove the Volume Knob" on page 7-11](#), install the Channel Select knob (32), channel select insert (36), Volume control knob (33), volume control insert (37), and volume torque o-ring (29).

7.7.2 Reassemble the Chassis Assembly

1. Ensure that the thermal pad (26) is attached to the back chassis (13). If it is not, attach a new thermal pad to the chassis heat sink island.
2. Install the transceiver board (65) by orienting the board at an angle so that it can be inserted into the antenna contact area of the back chassis (13), with the alignment post of the back chassis aligned with the alignment hole of the board. Once the chassis post and the board hole are aligned, the board can be lowered onto the support rails of the back chassis.

NOTE: Take care not to snag the RF contact clip (69) or the RF ground clip (35) on the back chassis during assembly.

3. Install the main shield (61) by orienting the shield at an angle so that it can be inserted into the antenna contact area of the back chassis (13), with the alignment post of the back chassis aligned with the alignment hole of the main shield. Once the chassis post and the main shield hole are aligned, the main shield can be lowered onto the surface of the transceiver board.
4. Install the 26-pin compression connector (62). It can only be inserted in one way: with the two-peg edge pointing downward on the right side.
5. While holding the 20-pin connectors of the control and display flex away from the surface of the main shield (61), install the VOCON board (64) by orienting the board at slight angle so that it can be inserted into the antenna contact area of the back chassis (13), with the alignment post of the back chassis aligned with the alignment hole of the board. Once the chassis post and the board hole are aligned, the board can be lowered onto the main shield.
6. Plug the 20-pin connector at the end of the LCD module flex into the mating connector on the VOCON board (64).
7. Plug the 20-pin connector at the end of the controls flex into the mating connector on the VOCON board (64).
8. If so equipped, install the encryption board (67) by orienting the board at a slight angle so that it can be inserted under the LCD bracket (21), while the board is being plugged into the 40-pin connector of the VOCON board (64).
9. Place the hex lock nut retainers (17) into the rounded end of the hex lock nuts (16).
10. Place two lock nuts (16) with retainers (17) into the lock nut recesses at the bottom of the back chassis (13), orienting the hex lock nut retainers towards the top of the radio and the flats of the nuts parallel to the sides of the nut recesses.
11. Install the front chassis assembly (50) into the back chassis assembly (13), orienting the speaker cone (56) towards the outside of the radio, and using the three chassis bolt bosses as assembly guides.
12. Insert three chassis bolts (60) through the front chassis (50). Using a ROTO-TORQ adjustable torque screwdriver with a T-10 TORX bit (see [Table 7-2 on page 7-10](#) for part numbers), tighten the three chassis bolts to 18 in-lbs.
13. Install the main seal/toggle support (63), orienting the toggle support part of the seal such that it hangs towards the bottom of the radio at the toggle switch side of the radio. Ensure that the main seal is captured between the front and back chassis and the control top (40).
14. Push the toggle switch support into the area between the front and back chassis, directly under the toggle switch backer.

7.7.3 Join the Chassis and Housing Assemblies

1. While holding the chassis assembly (13) in one hand and the housing assembly (1) in the other, insert the chassis assembly into the housing, orienting the speaker towards the front of the radio.

2. Push the chassis assembly into the housing, taking care not to pinch the main seal (63) between the housing (1) and the control top (40). Do not depress the PTT button during assembly.
3. Install the two self-sealing bolts (59) through the baseplate (2) on the bottom of the radio. Using a ROTO-TORQ adjustable torque screwdriver with a T-10 TORX bit (see [Table 7-2 on page 7-10](#) for part numbers), tighten the two self-sealing bolts to 18 in-lbs.

NOTE: Inspect the seals of the bolts before assembly. If the seals are damaged, discard both the seals and the bolts and replace with new self-sealing bolts.

7.7.4 Reassemble the Housing Baseplate

NOTE: All repairs to the baseplate assembly can, and should, be made with the radio chassis inside the radio.

1. Inspect the radio port seal (3).

NOTE: If the port seal is punctured or damaged, it must be replaced with a new port seal. If the port seal needs to be replaced, it can be peeled off of the housing. All residual adhesive on the housing must be removed before replacing the port seal.

2. Install the baseplate seal (9). Ensure that the baseplate seal is seated around the two threaded radio contact bushings and the remainder of the seal is in the baseplate seal recess of the housing.

NOTE: Inspect the baseplate seal for damage. If it is damaged, discard it and replace with a new seal.

3. Install the latch spring (7) into the latch spring recess in the housing, with the convex form facing the bottom of the radio.
4. Install the battery latch (4) into the battery latch recess in the housing, with the battery catch facing the bottom of the radio.
5. Install the baseplate (2), taking care not to push the baseplate seal (9) into the housing. You can verify this by looking into the bottom of housing to see if the seal has been pushed into the housing.
6. Install the baseplate contact insulator (8).
7. Install the three power contacts (6).
8. Install the three radio power contact screws (5) using a ROTO-TORQ adjustable torque screwdriver with a Phillips star bit (see [Table 7-2 on page 7-10](#) for part numbers). Tighten all three screws to 2.5 in-lbs.
9. If not done already, install the two self-sealing bolts (59) through the baseplate (2) on the bottom of the radio. Using a ROTO-TORQ adjustable torque screwdriver with a T-10 TORX bit (see [Table 7-2 on page 7-10](#) for part numbers), tighten the two self-sealing bolts to 18 in-lbs.

NOTE: Inspect the seals of the bolts before assembly. If the seals are damaged, discard both the seals and the bolts and replace with new self-sealing bolts.

NOTE: If the Channel Select knob (32) or Volume knob (33) were removed prior to servicing the main chassis, reinstall them. See [Section 7.5.1.2: "Install the Channel Select Knob" on page 7-11](#) and [Section 7.5.2.2: "Install the Volume Knob" on page 7-12](#).

Notes

Chapter 8 Troubleshooting

The purpose of this chapter is to aid in troubleshooting problems with the SSE 5000 radio. It is intended to be detailed enough to localize the malfunctioning circuit and isolate the defective component.

8.1 Voltage Measurement and Signal Tracing

It is always a good idea to check the battery voltage under load. This can be done by checking the OPT_B+_VPP pin at the accessory connector (pin 8). The battery voltage should remain at or above 7.0 Vdc. If the battery voltage is less than 7.0 Vdc, then it should be recharged or replaced as necessary prior to analyzing the radio.

In most instances, the problem circuit may be identified using a multimeter, an RF millivoltmeter, oscilloscope (preferably with 100 MHz bandwidth or more), and a spectrum analyzer.



Caution

When checking a transistor or module, either in or out of circuit, do not use an ohmmeter having more than 1.5 Vdc appearing across test leads or use an ohms scale of less than x100.

8.2 Standard Bias Table

Table 8-1 outlines some standard supply voltages and system clocks which should be present under normal operation. These should be checked as a first step to any troubleshooting procedure.

Table 8-1. Standard Operating Bias

Signal Name	Nominal Value	Tolerance	VOCON Board Source
13 MHz	13 MHz	±1000 ppm	C303
FLIP_32K	32.768 kHz	±400 ppm	R337
CKIH	16.8 MHz		R615
16_8MHz	16.8 MHz		C607
POR	3.0 Vdc	±5%	R725
RESET_OUT	3.0 Vdc	±5%	D401, pin 1
VSW1	3.85 Vdc	±5%	Test point TP501
VSW2	1.85 Vdc	±5%	Test point TP500
FILT_B+	7.5 Vdc	6.0-9.0 Vdc	C523
V2	3.0 Vdc	±5%	R560
GCAP_B+	7.5 Vdc	6.0-9.0 Vdc	R581
UNSW_B+	7.5 Vdc	6.0-9.0 Vdc	B702
SW_B+	7.5 Vdc	6.0-9.0 Vdc	R587
VCC5	5.0 Vdc	±5%	R503

8.3 Power-Up Error Codes

When the radio is turned on (power-up), the radio performs self-tests to determine if its basic electronics and software are in working order. When you turn the radio on normally, the radio performs a limited self-test. This allows the radio to achieve full power within two seconds. To allow the radio to perform a full self-test (which extends the time required to achieve full power), press and hold the **top side button** while turning the radio on. If the self-test is successful, you hear a chirp. If the self-test is unsuccessful, you hear a single, low-frequency tone and see an error code on the radio's display. The radio should be sent to the depot if cycling power and reprogramming the code plug do not solve the problem. The presence of an error should prompt the user that a problem exists and that a service technician may need to be contacted.

Self-test errors are classified as either fatal or non-fatal. Fatal errors will inhibit user operation; non-fatal errors will not. Use [Table 8-2](#) to aid in understanding particular power-up error code displays.

Table 8-2. Power-Up Error Code Displays

Error Code	Description	Error Type	Corrective Action
01/02	FLASH ROM Codeplug Checksum Error	Non-Fatal	1. Turn radio off, then on 2. Reprogram the radio codeplug
01/12	Security Partition Checksum Error	Non-Fatal	Reprogram the security codeplug
01/20	ABACUS Tune Failure	Non-Fatal	Turn radio off, then on
01/22	Tuning Codeplug Checksum Error	Non-Fatal	Reprogram the tuning codeplug, then retune the radio
01/82	FLASH ROM Codeplug Checksum Error	Fatal	Reprogram the radio codeplug
01/88	External RAM failure — Note: Not a checksum failure	Fatal	1. Turn radio off, then on 2. Reprogram the radio codeplug
01/90	General Hardware Failure	Fatal	Turn radio off, then on
01/92	Security Partition Checksum Error	Fatal	Reprogram the security codeplug
01/A0	ABACUS IC failure	Fatal	Turn radio off, then on
01/A2	Tuning Codeplug Checksum Error	Fatal	Reprogram the tuning codeplug, then retune the radio
02/88	DSP RAM failure — Note: Not a checksum failure	Fatal	Turn radio off, then on
02/90	General DSP Hardware Failure (DSP startup message not received correctly)	Fatal	Turn radio off, then on
09/10	Secure Hardware Error	Non-Fatal	Turn the radio off, then on.
09/90	Secure Hardware Fatal Error	Fatal	Turn the radio off, then on.
<p>Note: If more than one corrective action is listed, try the first one to see if it fixes the problem before trying the second one. If none of the actions listed fixes the problem, or if your radio displays an error code other than those shown above, send the radio to the depot.</p>			

8.4 Operational Error Codes

During radio operation, the radio performs dynamic tests to determine if the radio is working properly. Problems detected during these tests are presented as error codes on the radio's display. The presence of an error code should prompt a user that a problem exists and that a service technician should be contacted. Use [Table 8-3](#) to aid in understanding particular operational error codes.

Table 8-3. Operational Error Code Displays

Error Code	Description	Corrective Action
FAIL 001	Synthesizer Out-of-Lock	1. Reprogram external codeplug 2. If 1 does not work, then send radio to depot
FAIL 002	Selected Mode/Zone Codeplug Checksum Error	Reprogram external codeplug

8.5 Receiver Troubleshooting

[Table 8-4](#) lists the possible causes of, and corrections for, receiver problems.

Table 8-4. Receiver Troubleshooting Chart

Symptom	Possible Cause	Correction or Test (Measurements at Room Temperature)
Radio Dead; Display Does Not Turn On	1. Dead Battery	Replace with charged battery
	2. Blown Fuse	Send radio to depot
	3. On/Off Switch	
	4. Regulators	
Radio Dead; Display Turns On	1. VOCON Board 2. RF Board	Send radio to depot
No Receive Audio, or Receiver Does Not Unmute	Programming	1. Does the transmitted signal match the receiver configuration (PL, etc.)? 2. With the monitor function enabled, can the radio be unmuted?
Audio Distorted or Not Loud Enough	Synthesizer Not On Frequency	Check synthesizer frequency by measuring the transmitter frequency; realign if off by more than ± 1000 Hz
RF Sensitivity Poor	1. Synthesizer Not On Frequency	Check synthesizer frequency by measuring the transmitter frequency; realign if off by more than ± 1000 Hz
	2. Antenna Switch/Connector	Send radio to depot
Radio Will Not Turn Off	VOCON Board	Send radio to depot

8.6 Transmitter Troubleshooting

Table 8-5 lists the possible causes of, and corrections for, transmitter problems.

Table 8-5. Transmitter Troubleshooting Chart

Symptom	Possible Cause	Correction or Test (Measurements Taken at Room Temperature)
No RF Power Out	1. TX Power Level or Frequency	Check TX power level and frequency programming (from tuner)
	2. No Injection To Power Amplifier	Send radio to depot
	3. Antenna Switch/Connector	
No Modulation; Distorted Modulation	1. Programming	Check deviation and compensation settings using the tuner
	2. VOCON Board	Send radio to depot
Bad Microphone Sensitivity	1. Check Deviation and Compensation	Realign if necessary
	2. Microphone	Send radio to depot
No/Low signaling (PL, DPL, MDC)	1. Programming	Check programming
	2. VOCON Board	Send radio to depot
Cannot Set Deviation Balance	RF Board	Send radio to depot

8.7 Encryption Troubleshooting

Table 8-6 lists the possible causes of, and corrections for, encryption problems.

Table 8-6. Encryption Troubleshooting Chart

Symptom	Possible Cause	Corrective Action
No "KEYLOAD" on Radio Display When Keyloading Cable is Attached to the Radio Side Connector	1. Defective Keyload Cable	Send radio to depot
	2. Defective Radio	
Keyloader Displays "KEY LOAD FAILURE!"	1. Wrong Keyloader Type	Use correct keyloader type. Refer to Keyloader User Guide for more information
	2. Bad Keyloader	Try another keyloader
	3. Defective Radio	Send radio to depot

Chapter 9 Troubleshooting Charts

This section contains detailed troubleshooting flowcharts. These charts should be used as a guide in determining the problem areas. They are not a substitute for knowledge of circuit operation and astute troubleshooting techniques. It is advisable to refer to the related detailed circuit descriptions in the theory of operation sections prior to troubleshooting a radio.

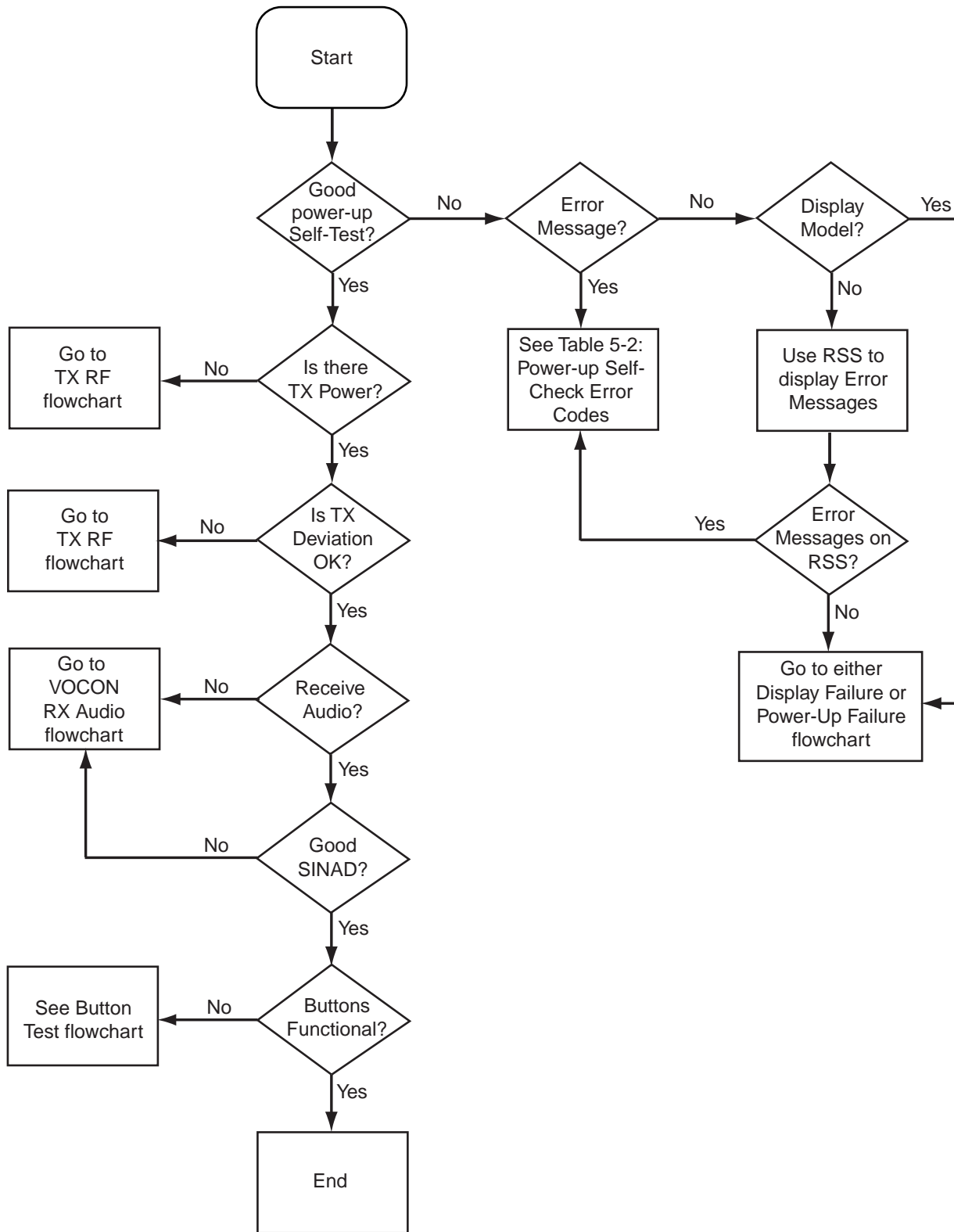
9.1 List of Troubleshooting Charts

Most troubleshooting charts (see [Table 9-1](#)) end up by pointing to an IC to replace. **It is not always noted, but it is good practice to verify supplies and grounds to the affected IC and to trace continuity to the malfunctioning signal and related circuitry before replacing any IC.** For instance, if a clock signal is not available at a destination, continuity from the source IC should be checked before replacing the source IC.

Table 9-1. Troubleshooting Charts List

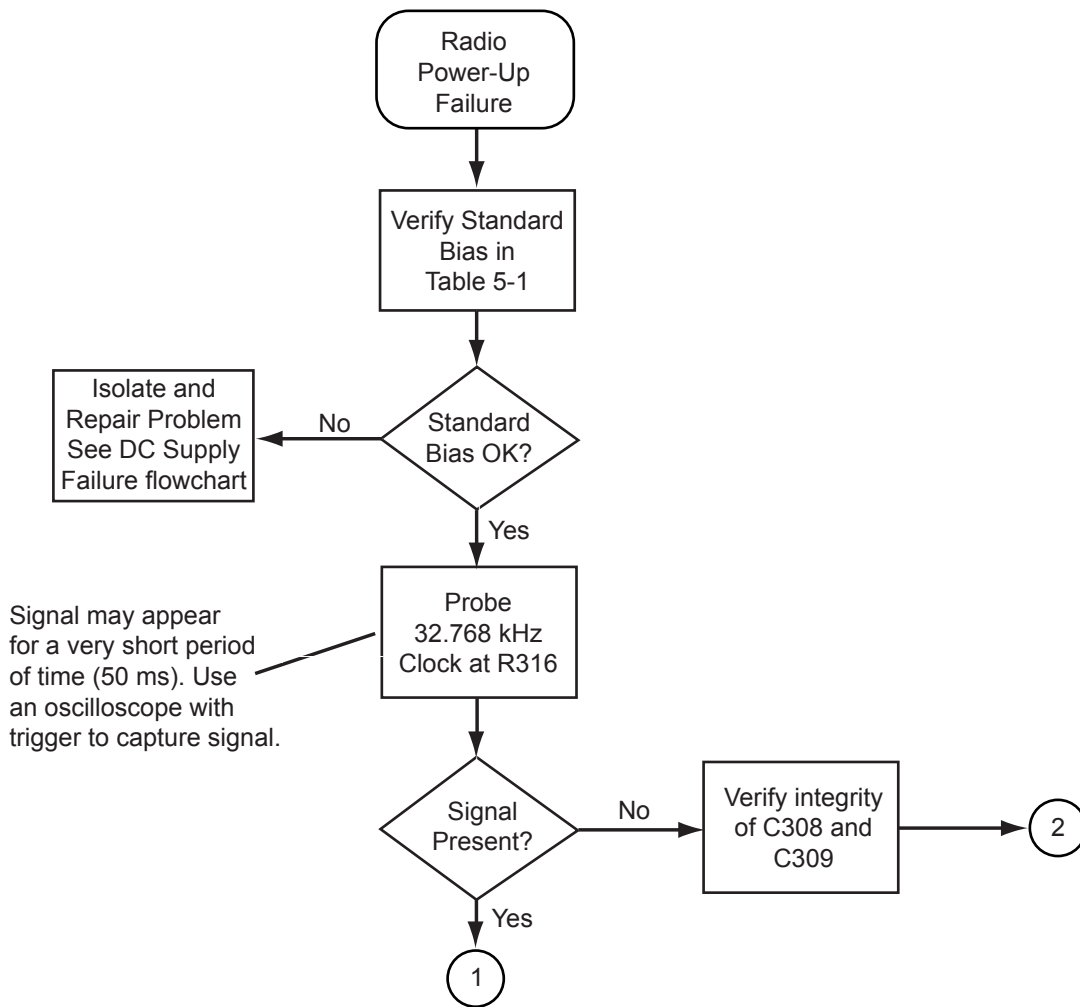
Chart Title	Page Number
Main Troubleshooting Flowchart	9-2
Power-Up Failure	9-3
DC Supply Failure	9-5
Display Failure	9-8
Volume Set Error	9-11
Channel Select Error	9-12
Button Test	9-13
Top/Side Button Test	9-14
VCO TX/RX Unlock	9-15
VOCON TX Audio	9-16
VOCON RX Audio	9-18
RX RF	9-20
TX RF	9-25
Keyload Failure	9-28
Secure Hardware Failure	9-29

9.2 Main Troubleshooting Flowchart



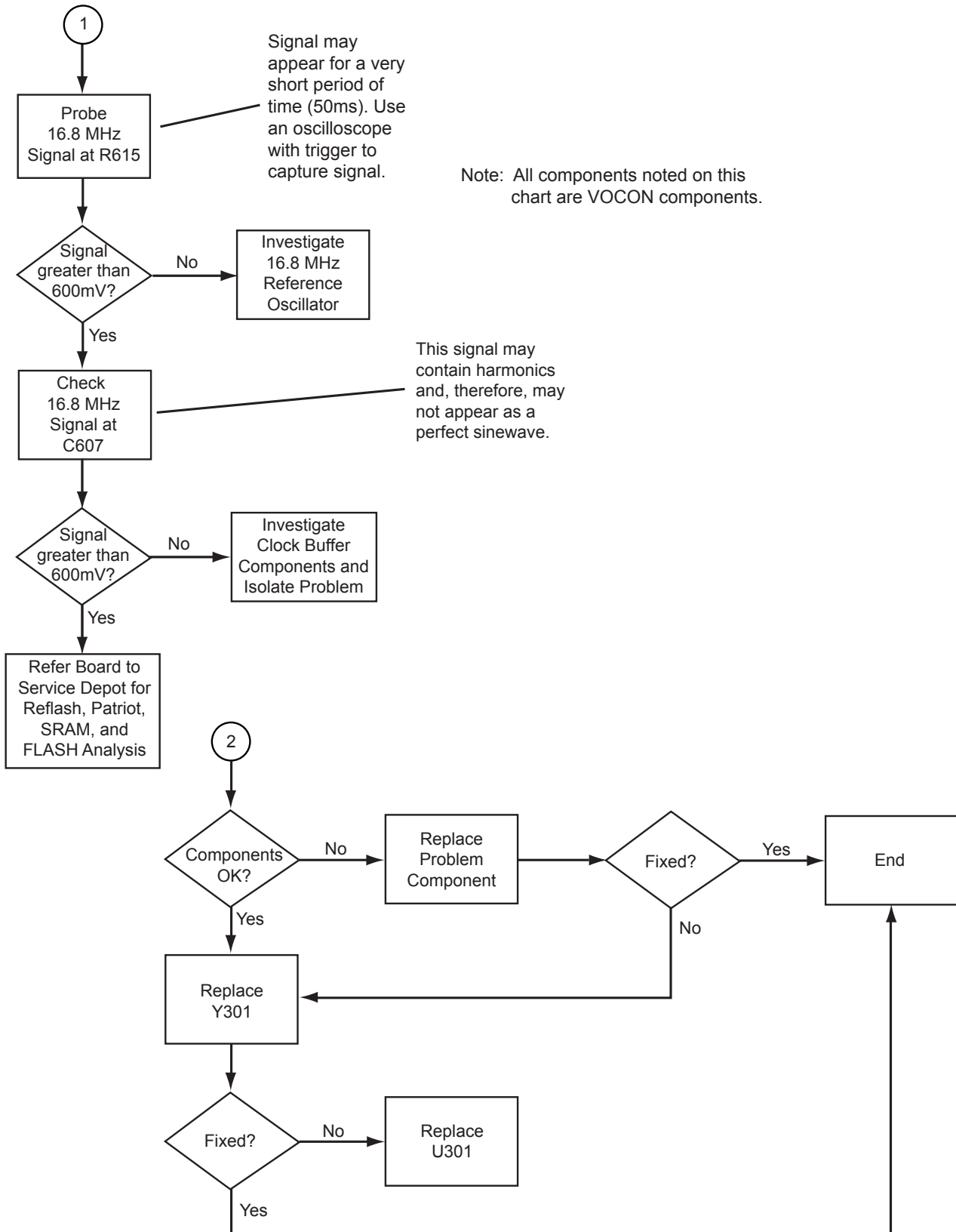
MAEPF-27403-A

9.3 Power-Up Failure—Page 1



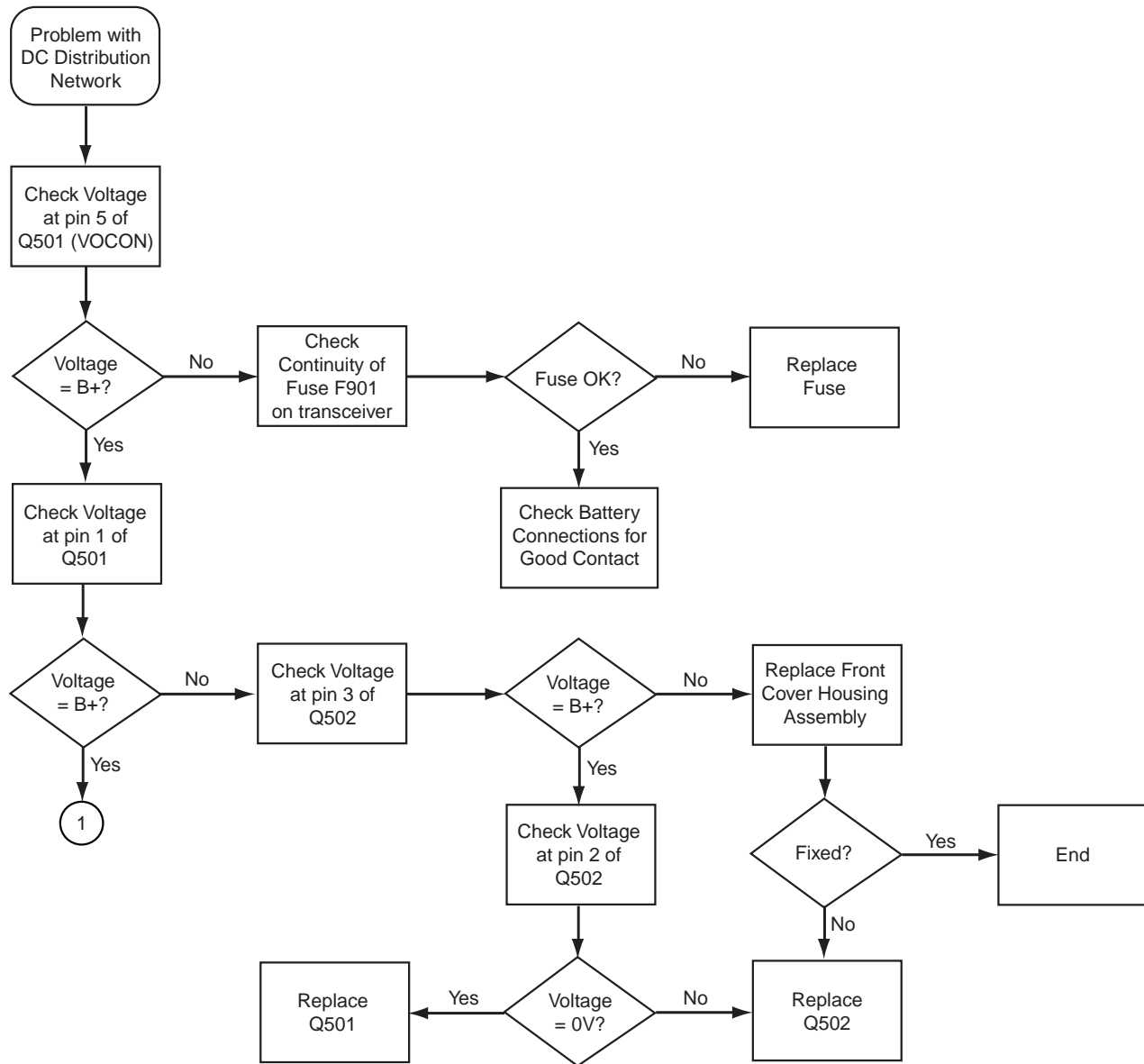
MAEPF-27389-D

Power-Up Failure—Page 2



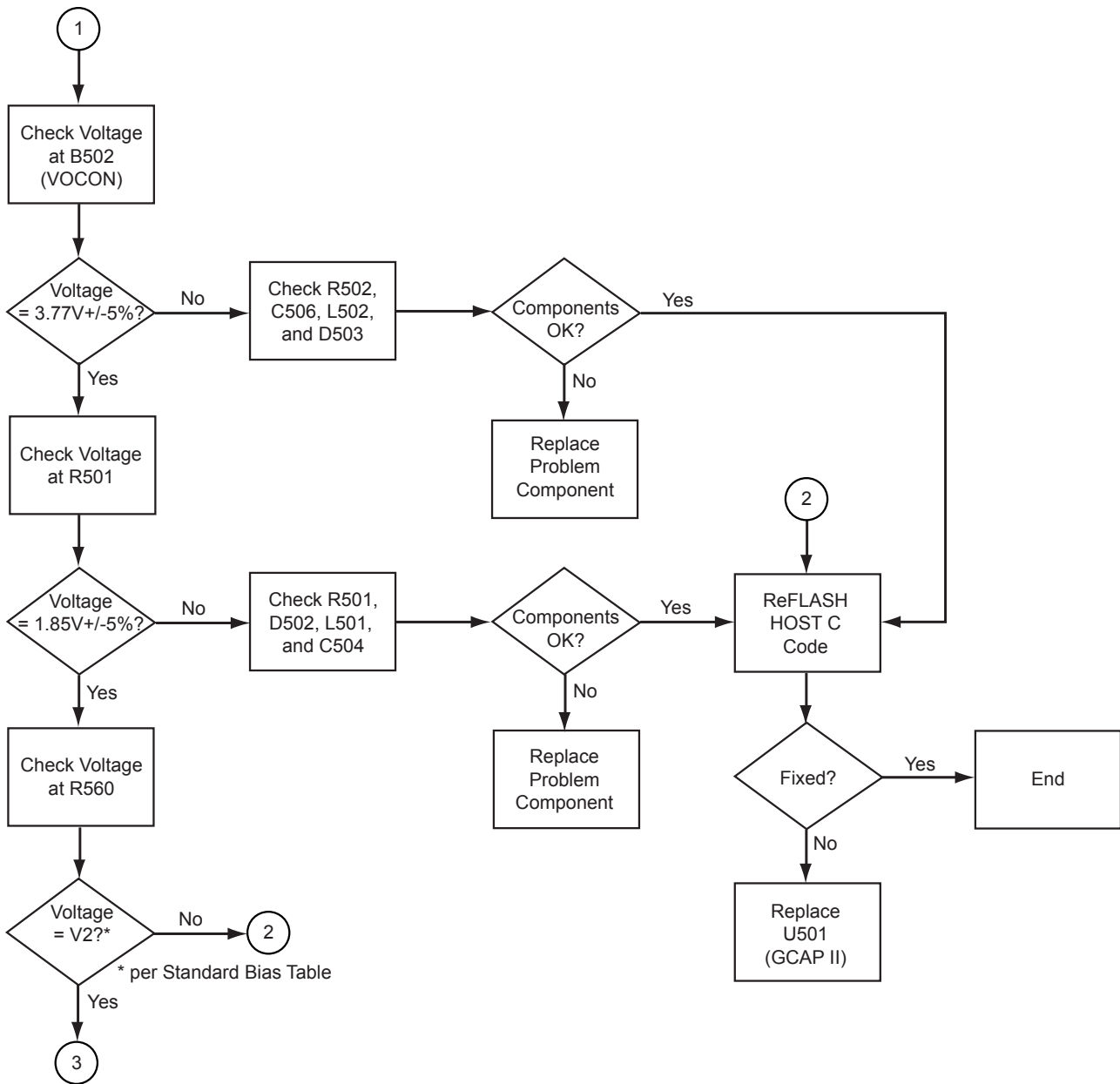
9.4 DC Supply Failure—Page 1

NOTE: Since the failure of a critical voltage supply might cause the radio to automatically power down, supply voltages should first be probed with a multimeter. If all the board voltages are absent, then the voltage test point should be retested using a rising-edge-triggered oscilloscope. If the voltage is still absent, then another voltage should be tested using the oscilloscope. If that voltage is present, then the original voltage supply in question is defective and requires investigation of associated circuitry.



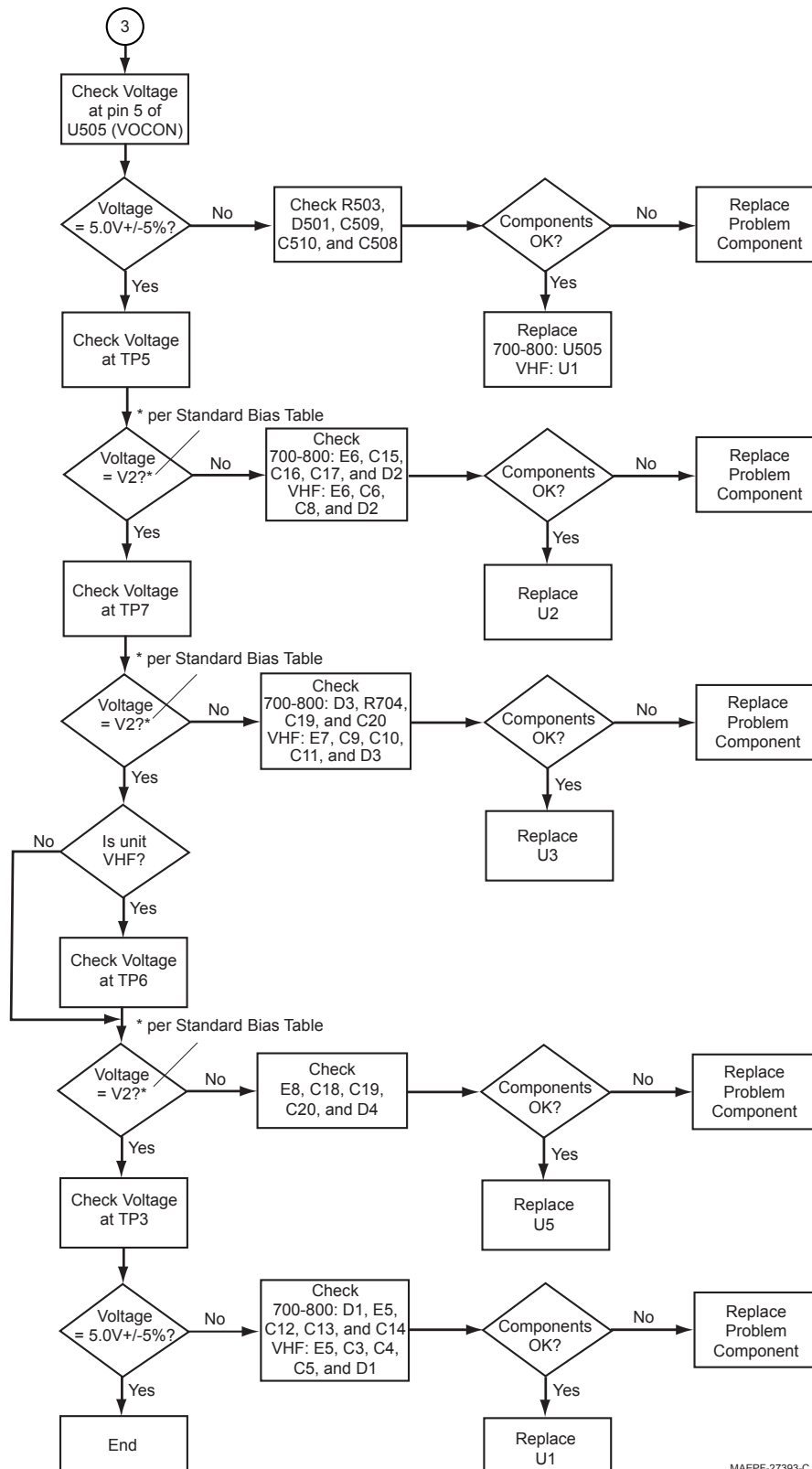
MAEPF-27391-A

DC Supply Failure—Page 2



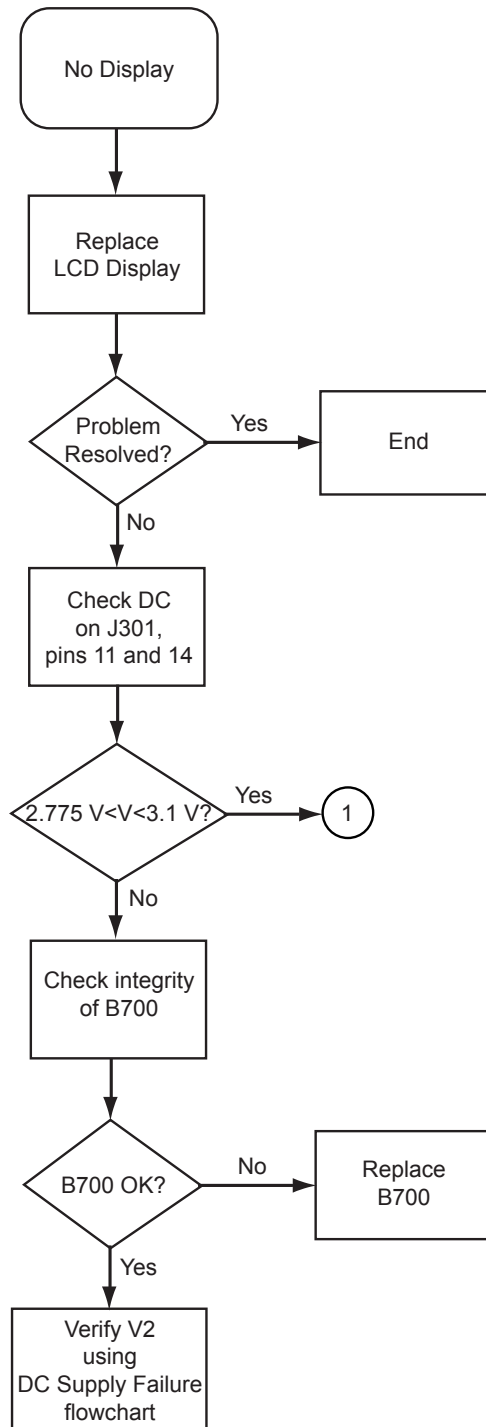
MAEPF-27392-C

DC Supply Failure—Page 3



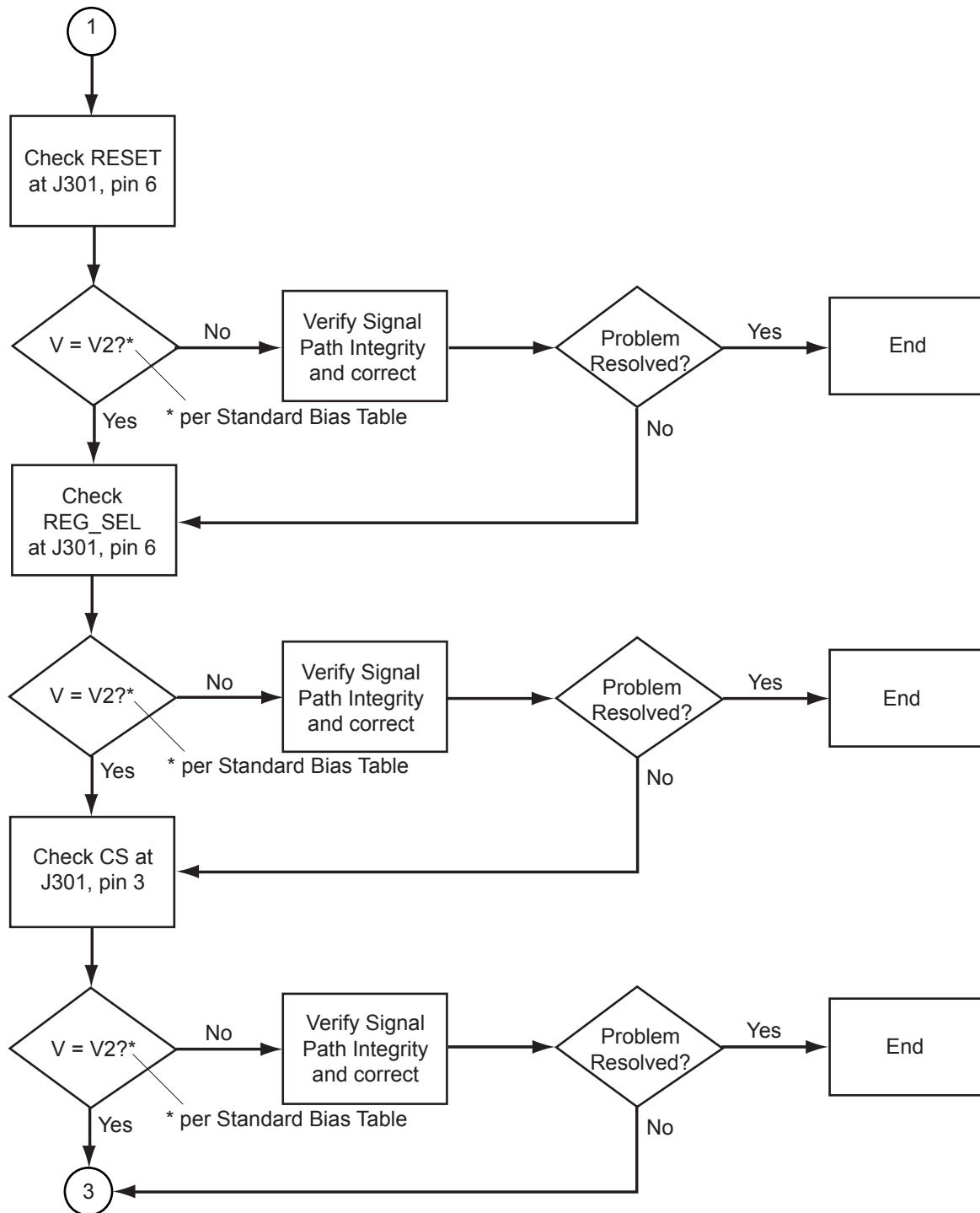
MAEPF-27393-C

9.5 Display Failure—Page 1



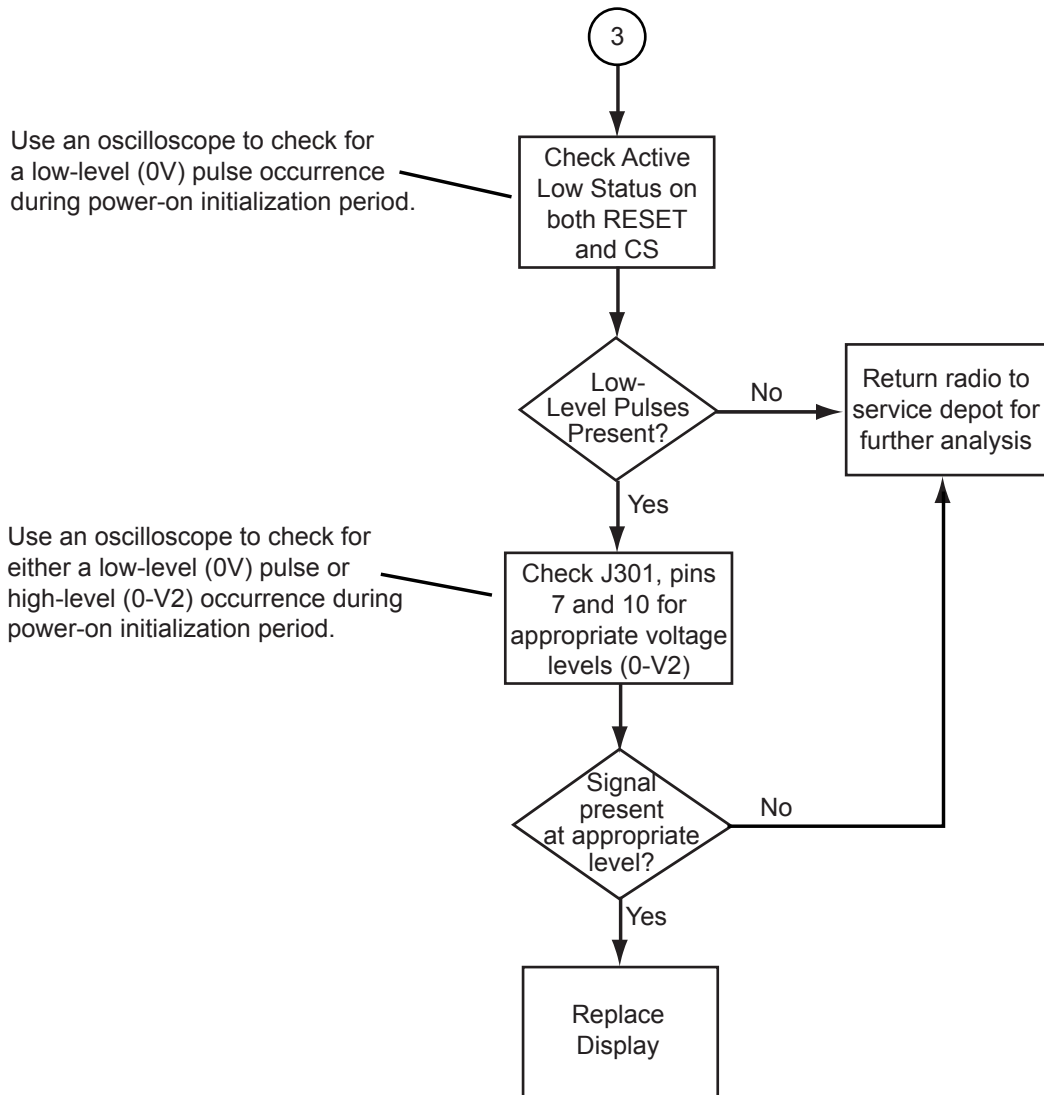
MAEPF-27505-C

Display Failure—Page 2



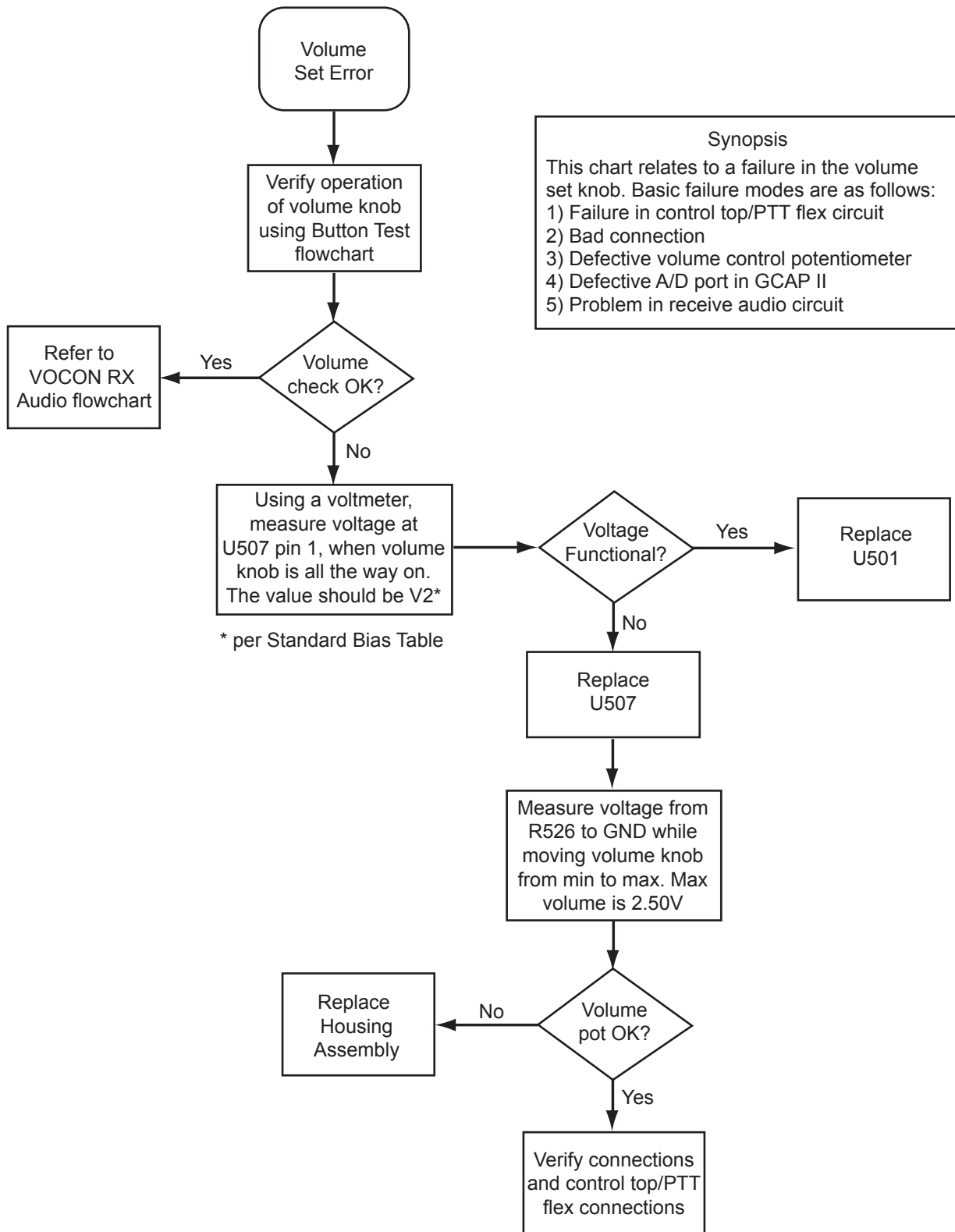
MAEPF-27506-B

Display Failure—Page 3



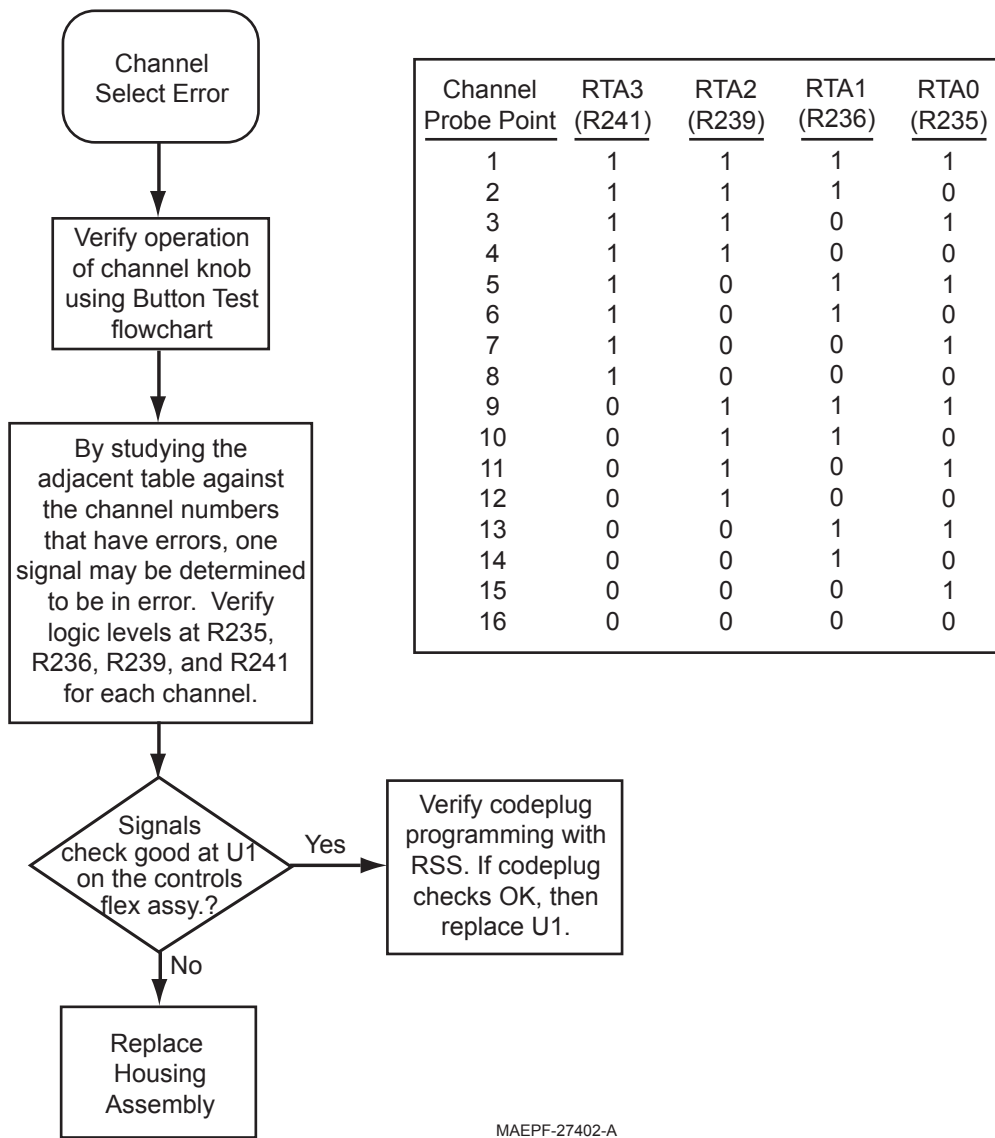
MAEPF-27507-B

9.6 Volume Set Error

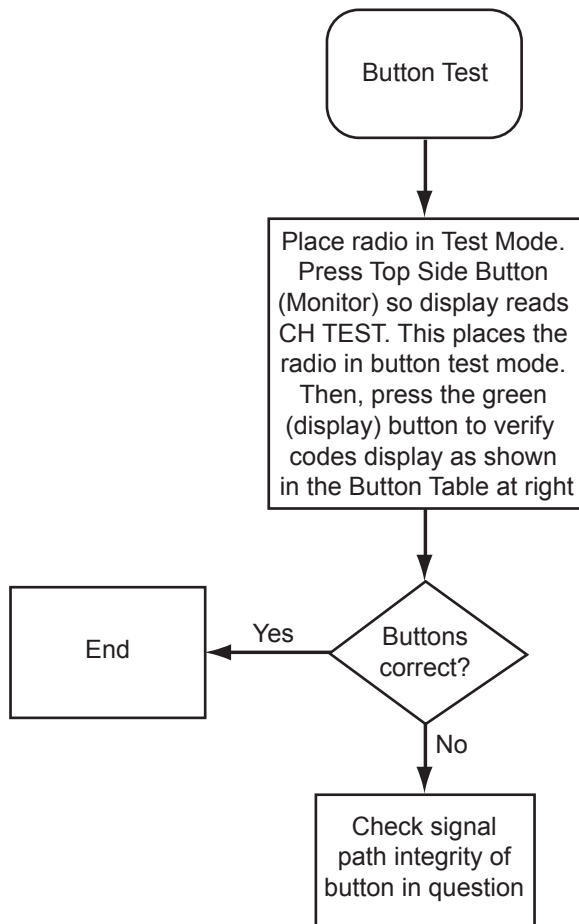


MAEPF-27401-B

9.7 Channel Select Error



9.8 Button Test



Synopsis

This chart relates to a failure in the button functions. Basic Failure modes are as follows:

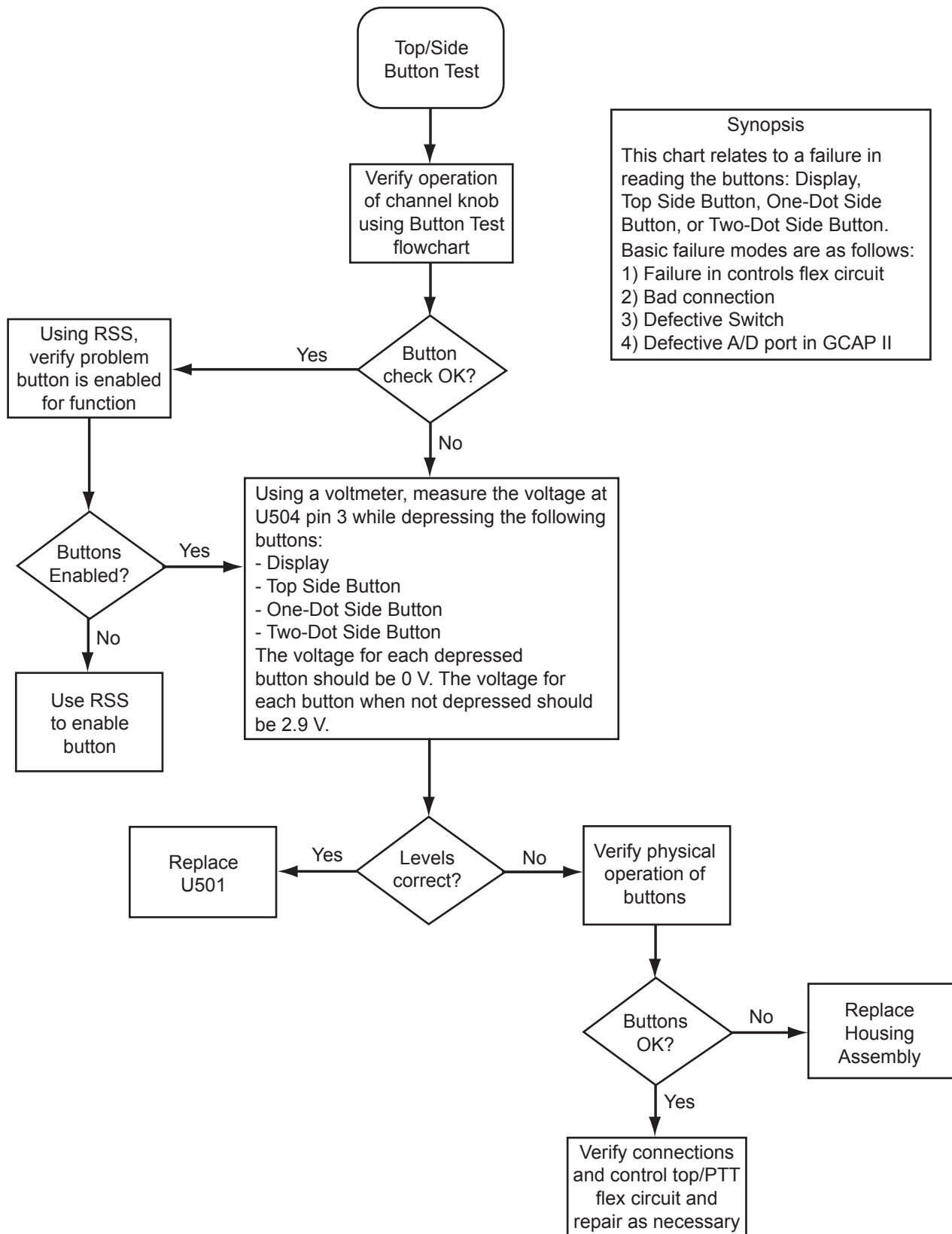
- 1) Failure in control top/PTT
- 2) Bad Connection
- 3) Defective Switches or pads
- 4) Defective A/D port in GCAP II

Button Table

<u>Button</u>	<u>Code</u>
PTT	1/ 0-1
Volume Control Knob	2/ 0-255
Display Button	3/ 0-1
Channel Select (Frequency)	4/ 0-15
Channel Bank Select	67/ 0-2
Top Side Button (Monitor)	96/ 0-1
Two-Dot Side Button	97/ 0-1
One-Dot Side Button	98/ 0-1

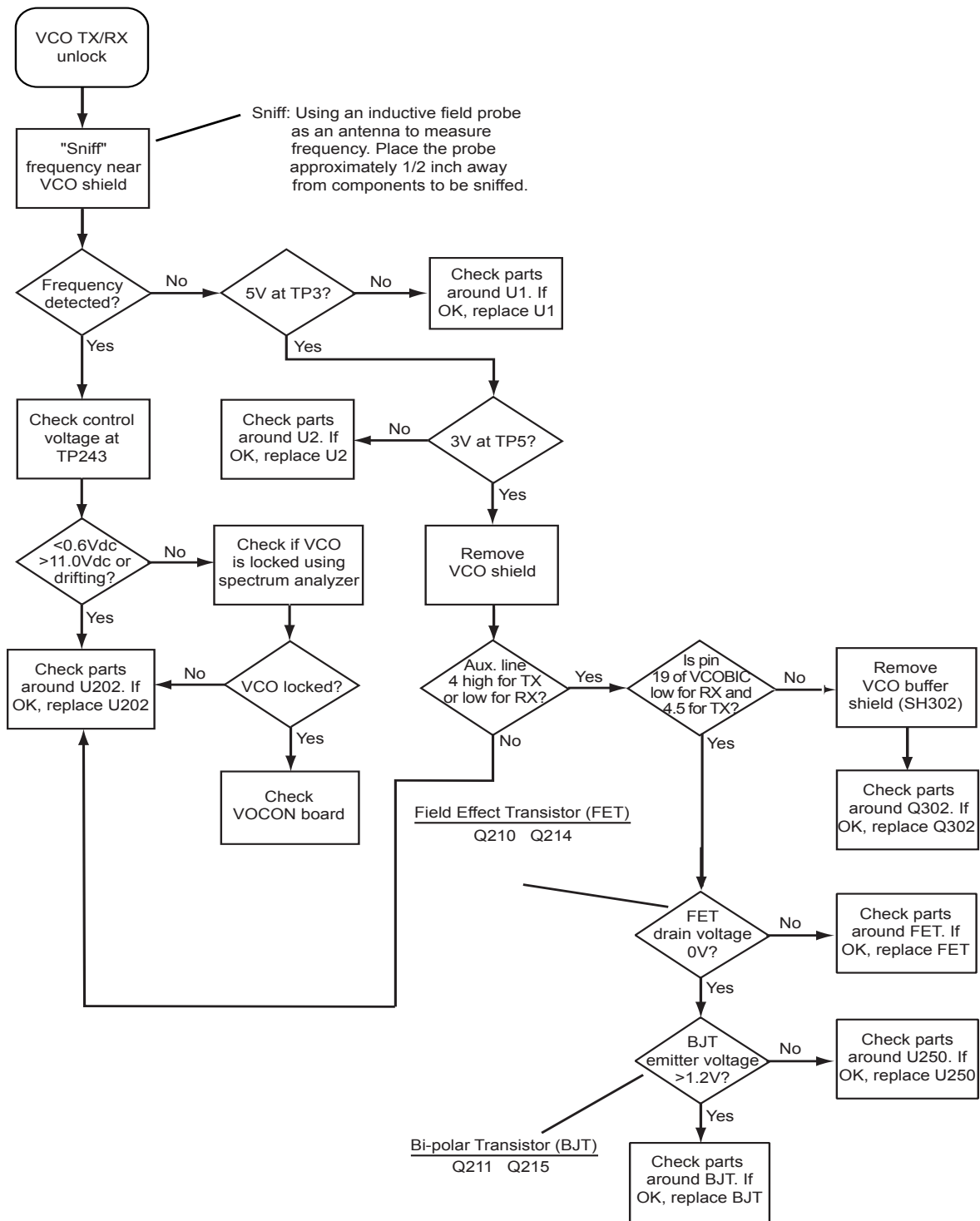
MAEPF-27399-A

9.9 Top/Side Button Test



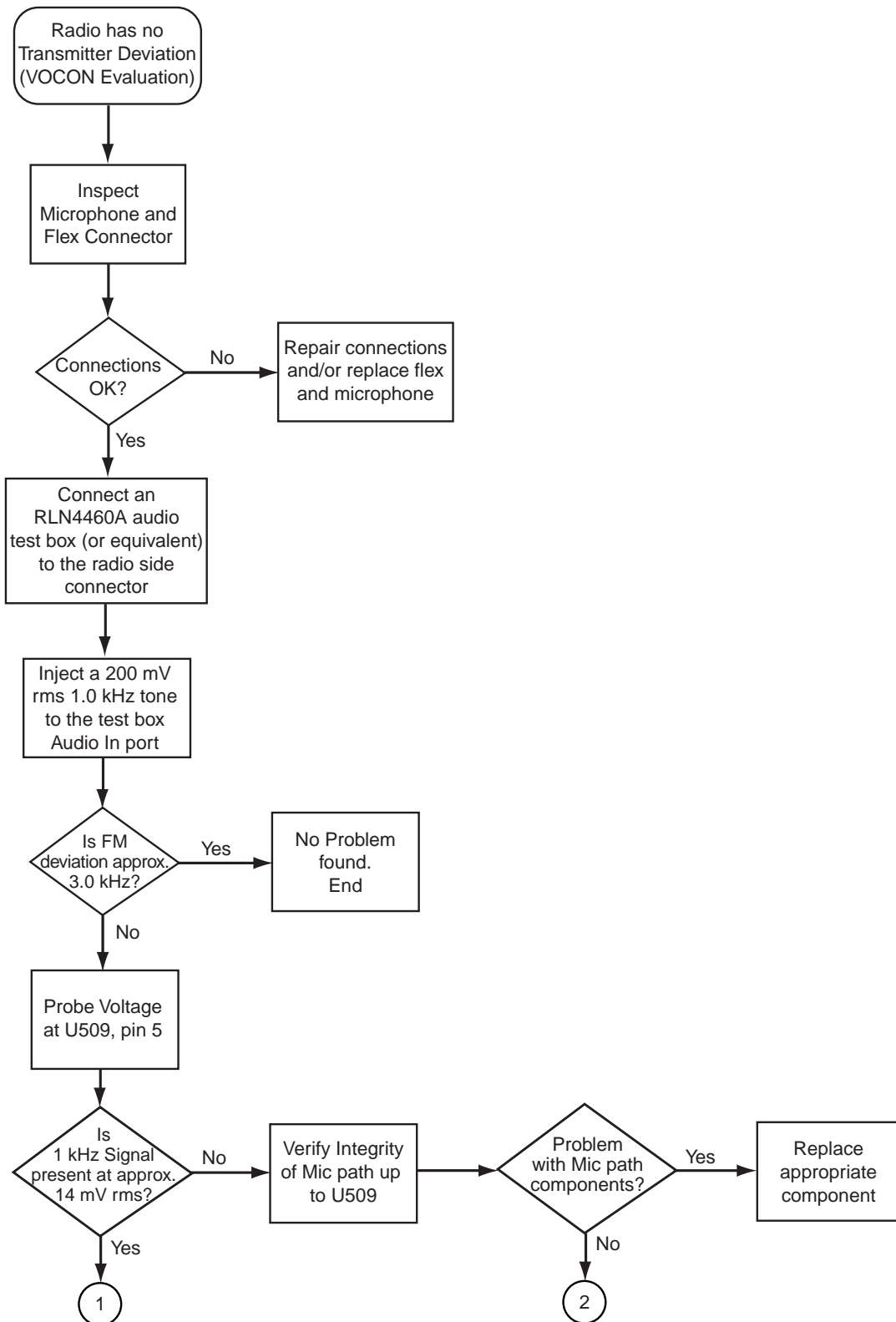
Synopsis
 This chart relates to a failure in reading the buttons: Display, Top Side Button, One-Dot Side Button, or Two-Dot Side Button. Basic failure modes are as follows:
 1) Failure in controls flex circuit
 2) Bad connection
 3) Defective Switch
 4) Defective A/D port in GCAP II

9.10 VCO TX/RX Unlock



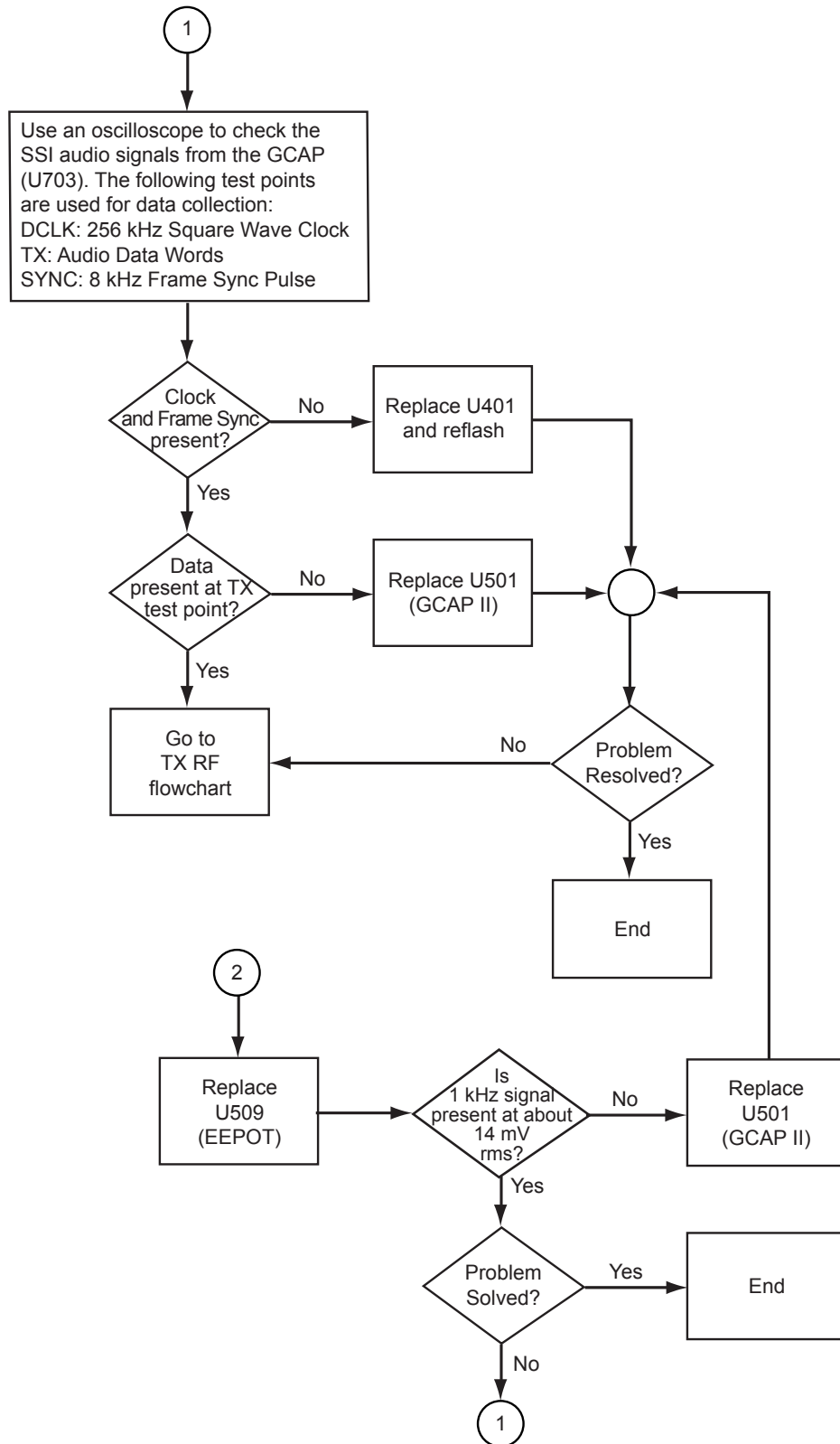
MAEPF-27398-A

9.11 VOCON TX Audio—Page 1



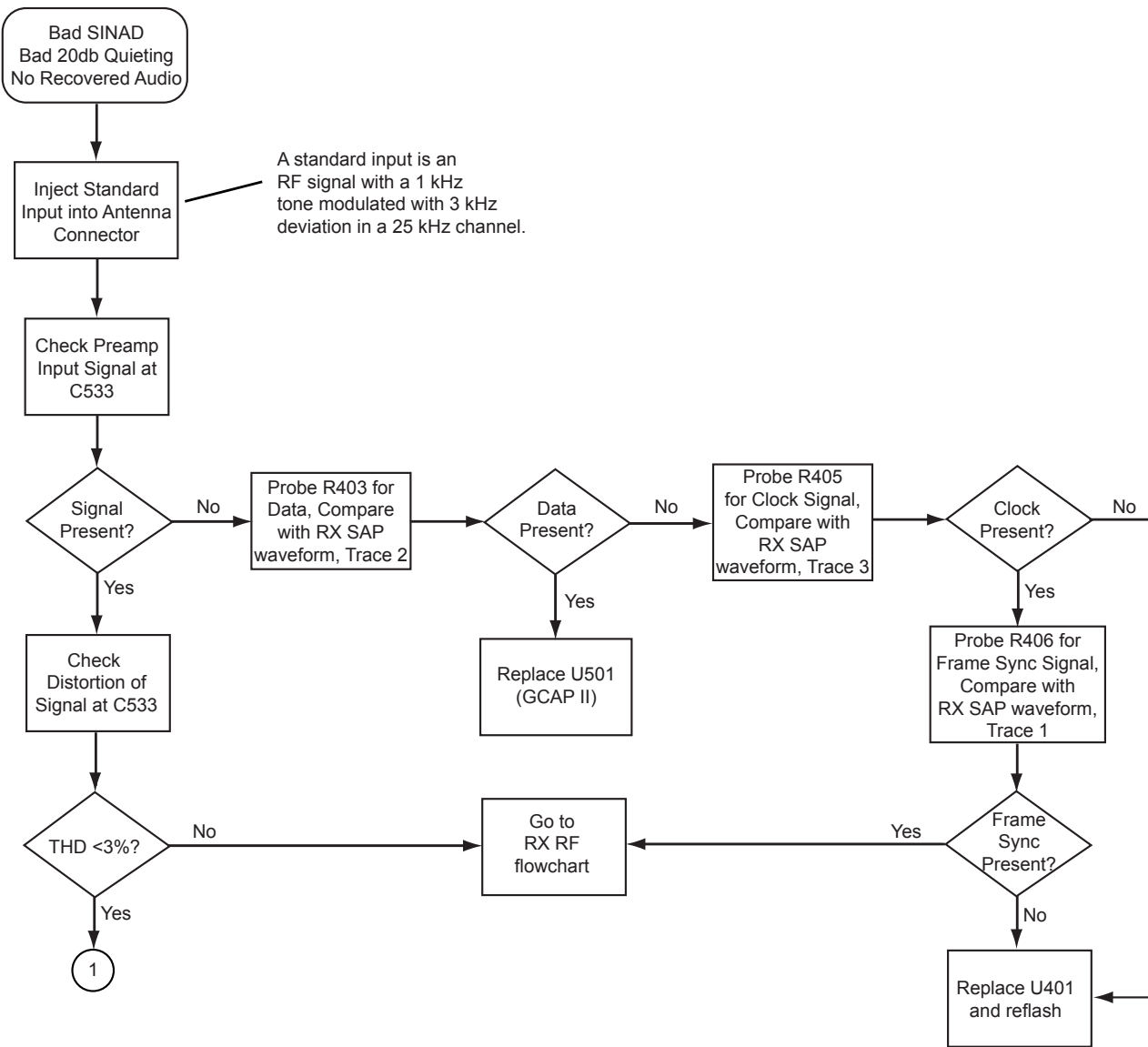
MAEPF-27396-O

VOCON TX Audio—Page 2



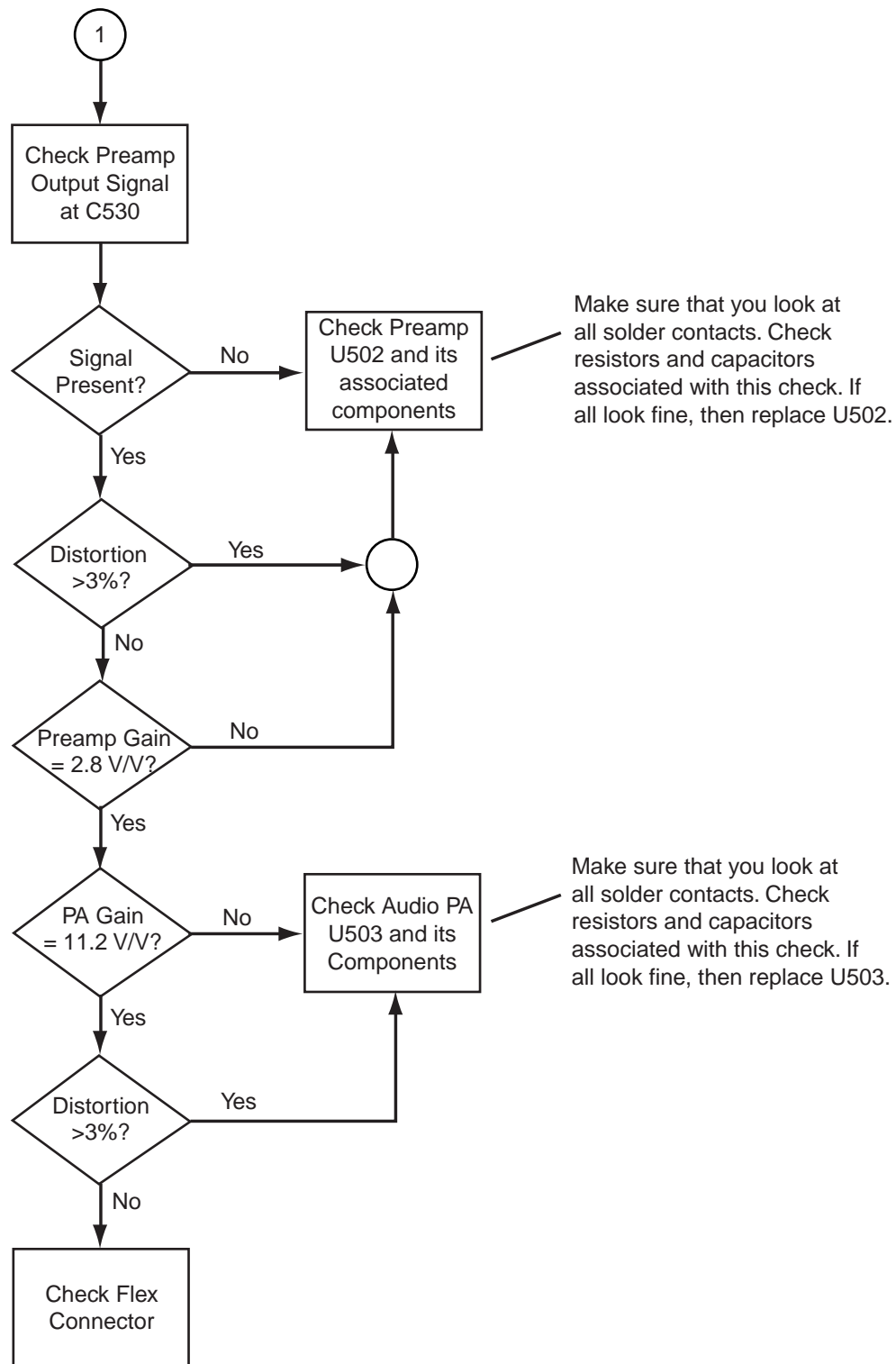
MAEPF-27397-B

9.12 VOCON RX Audio—Page 1



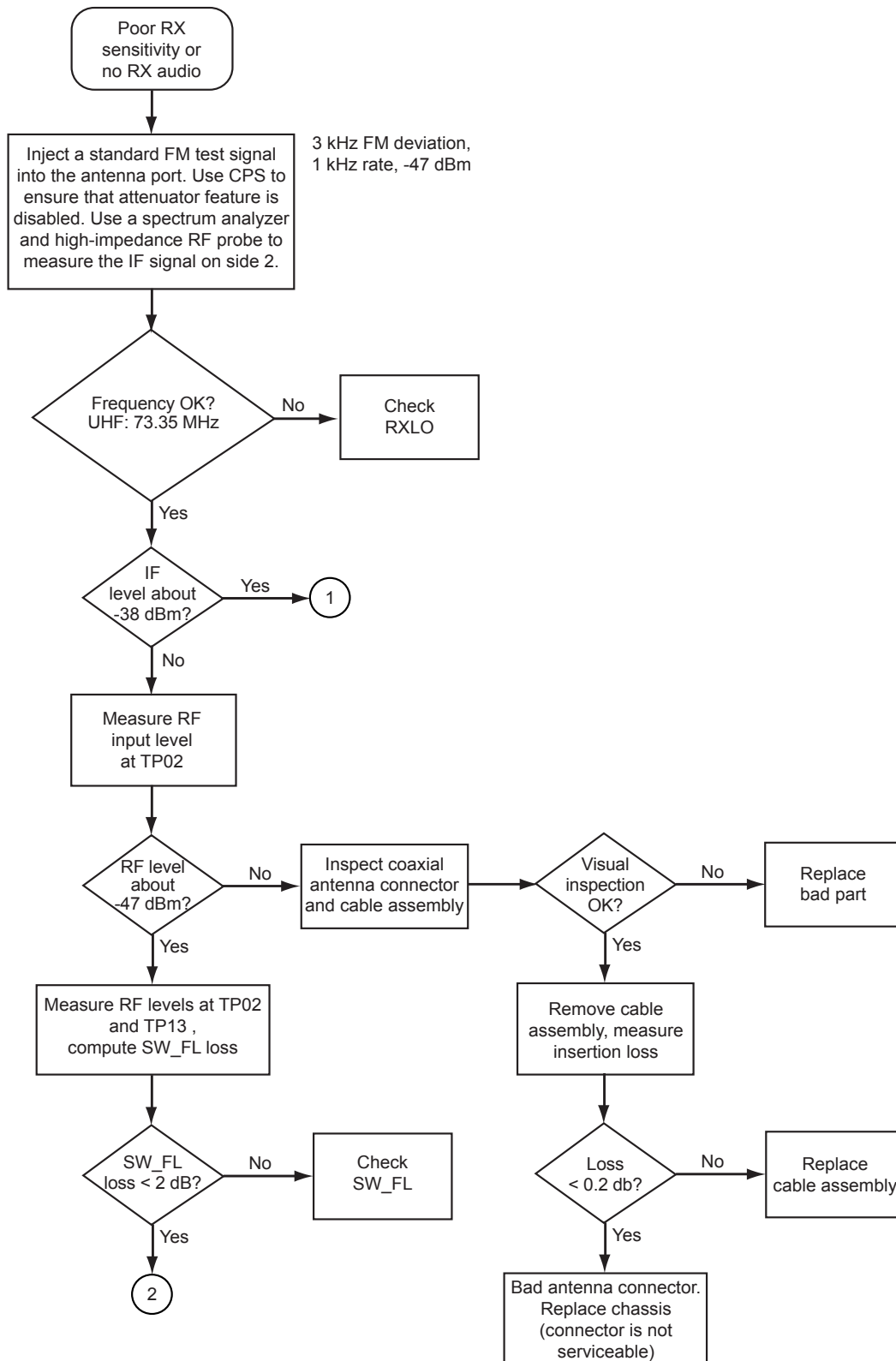
MAEPF-27394-B

VOCON RX Audio—Page 2



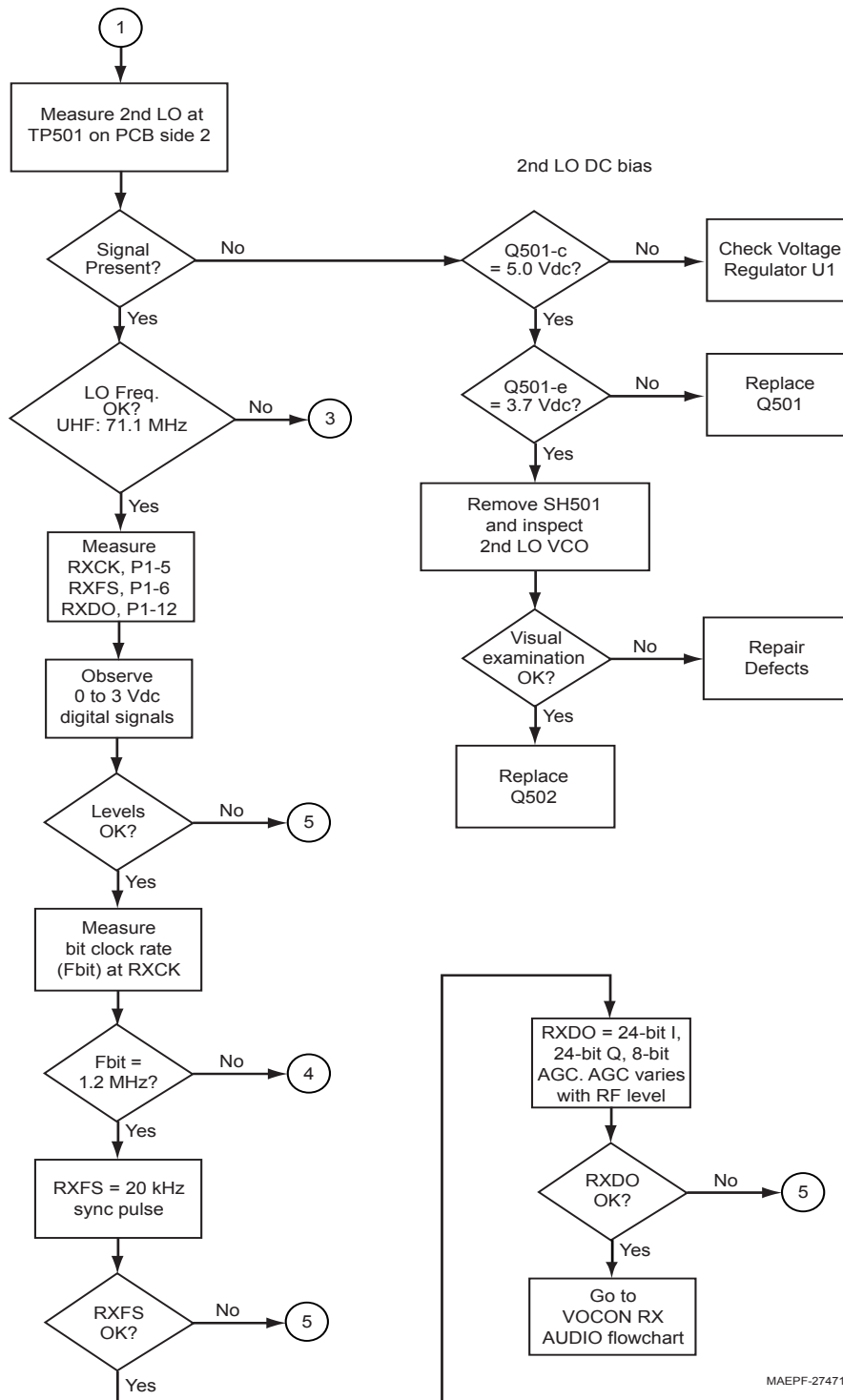
MAEPF-27395-O

9.13 RX RF—Page 1



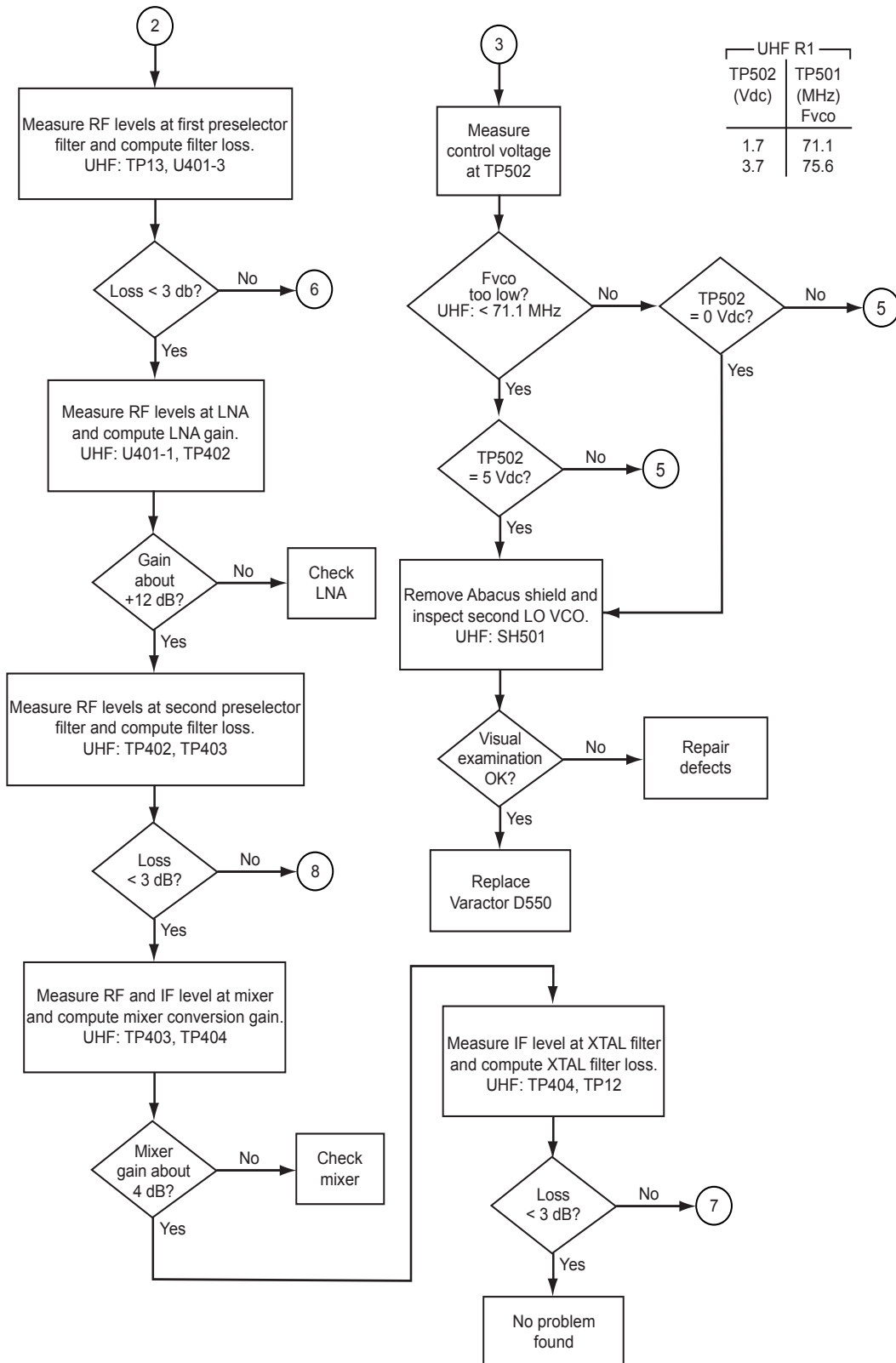
MAEPF-27470-B

RX RF—Page 2



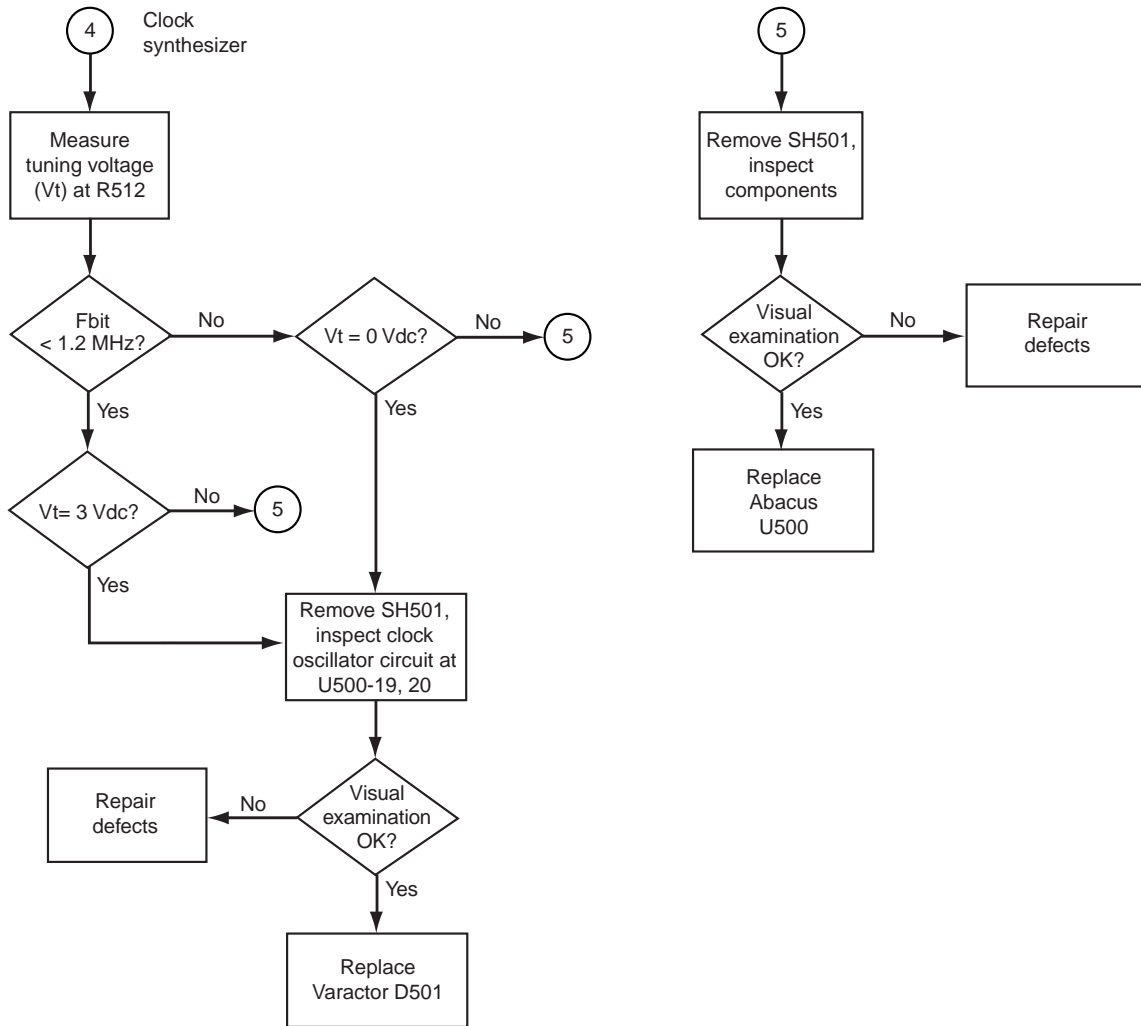
MAEPF-27471-B

RX RF—Page 3



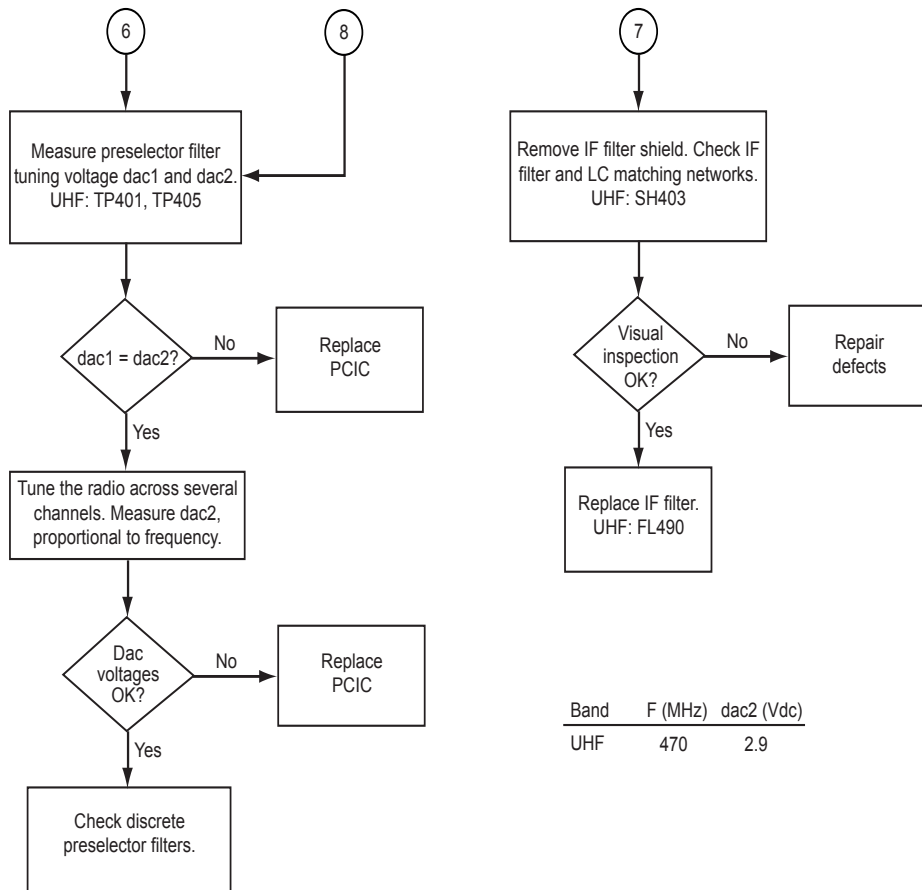
MAEPF-27472-B

RX RF—Page 4



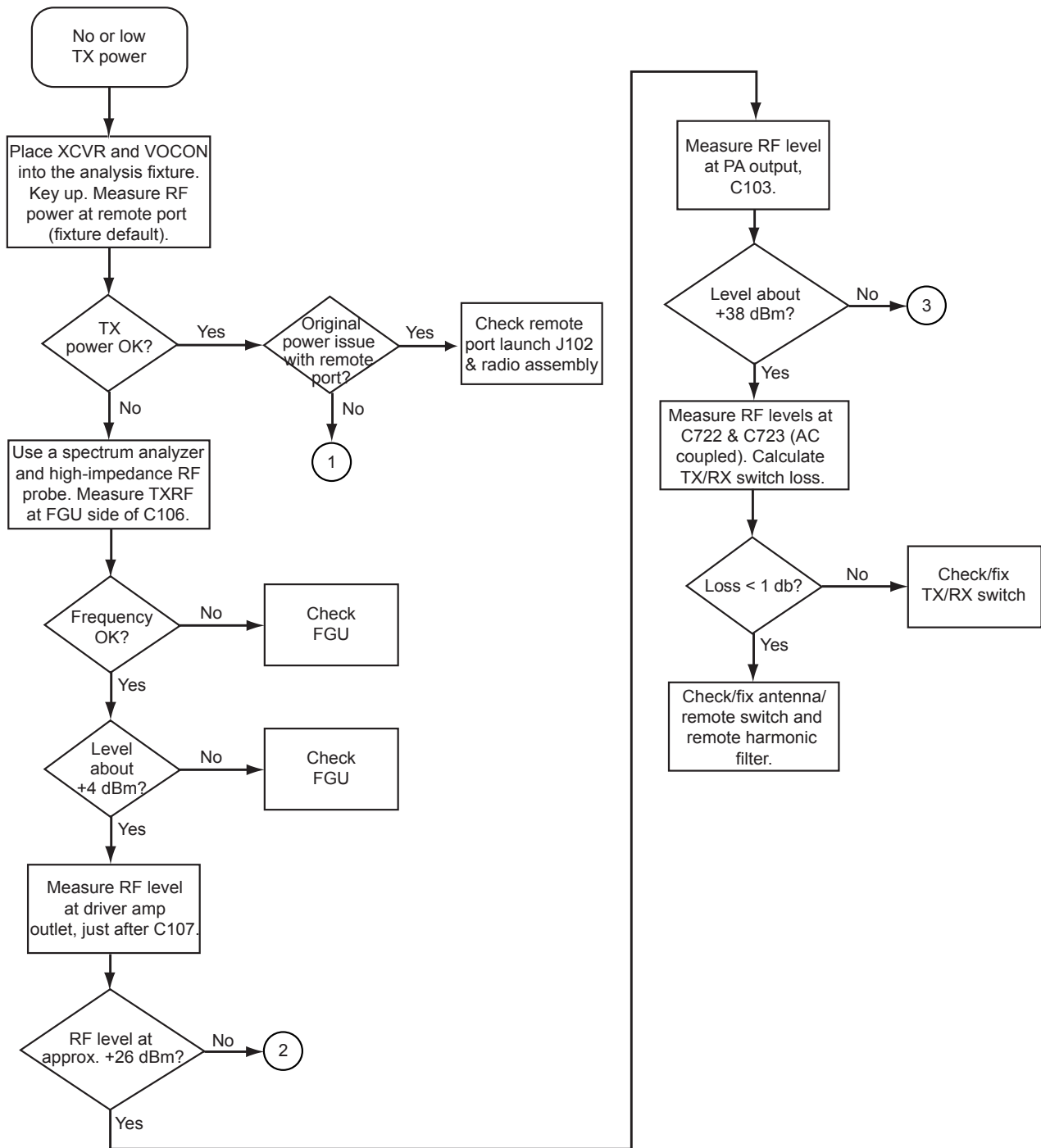
MAEPF-27473-O

RX RF—Page 5



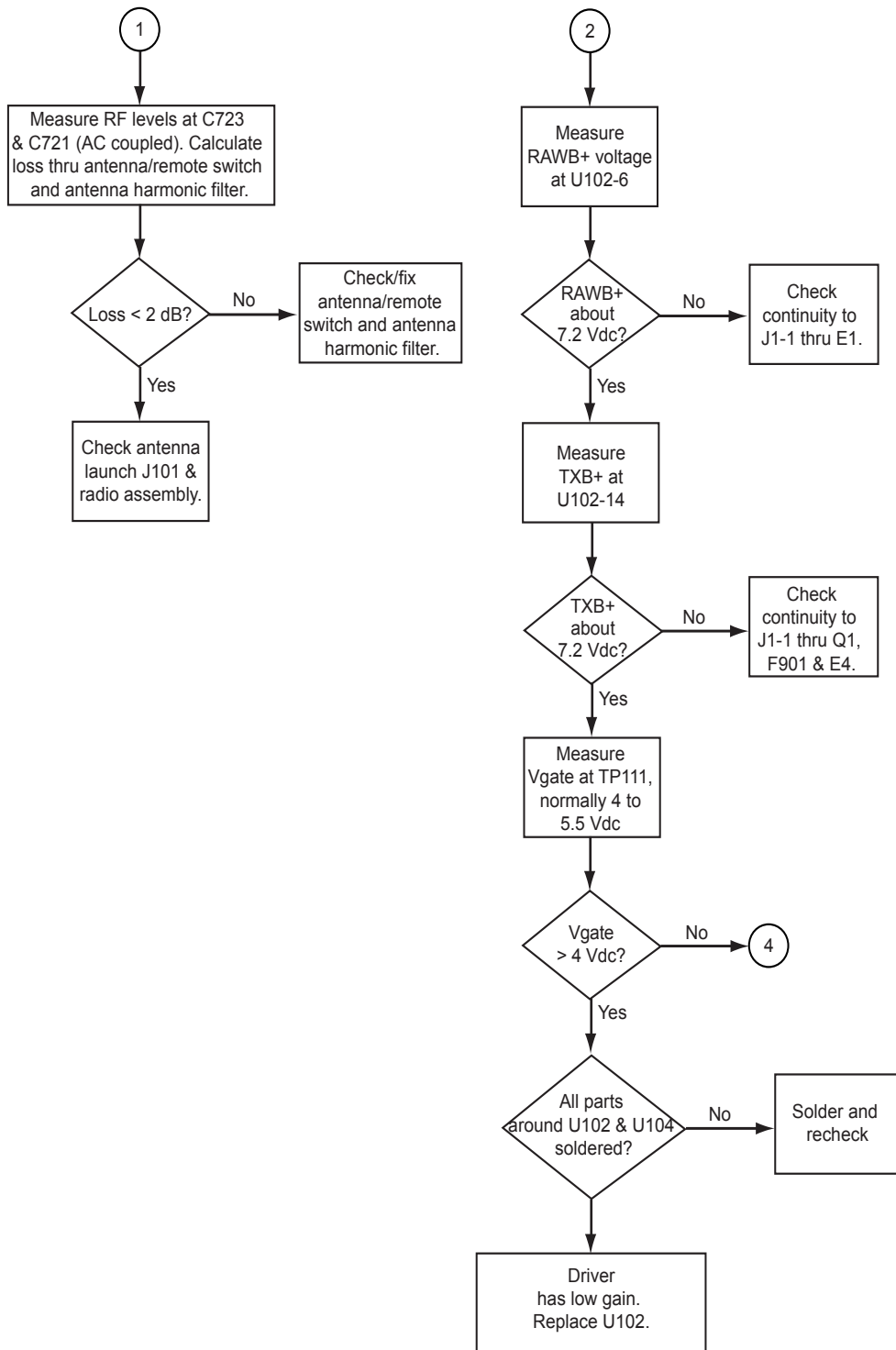
MAEPF-27474-B

9.14 TX RF—Page 1



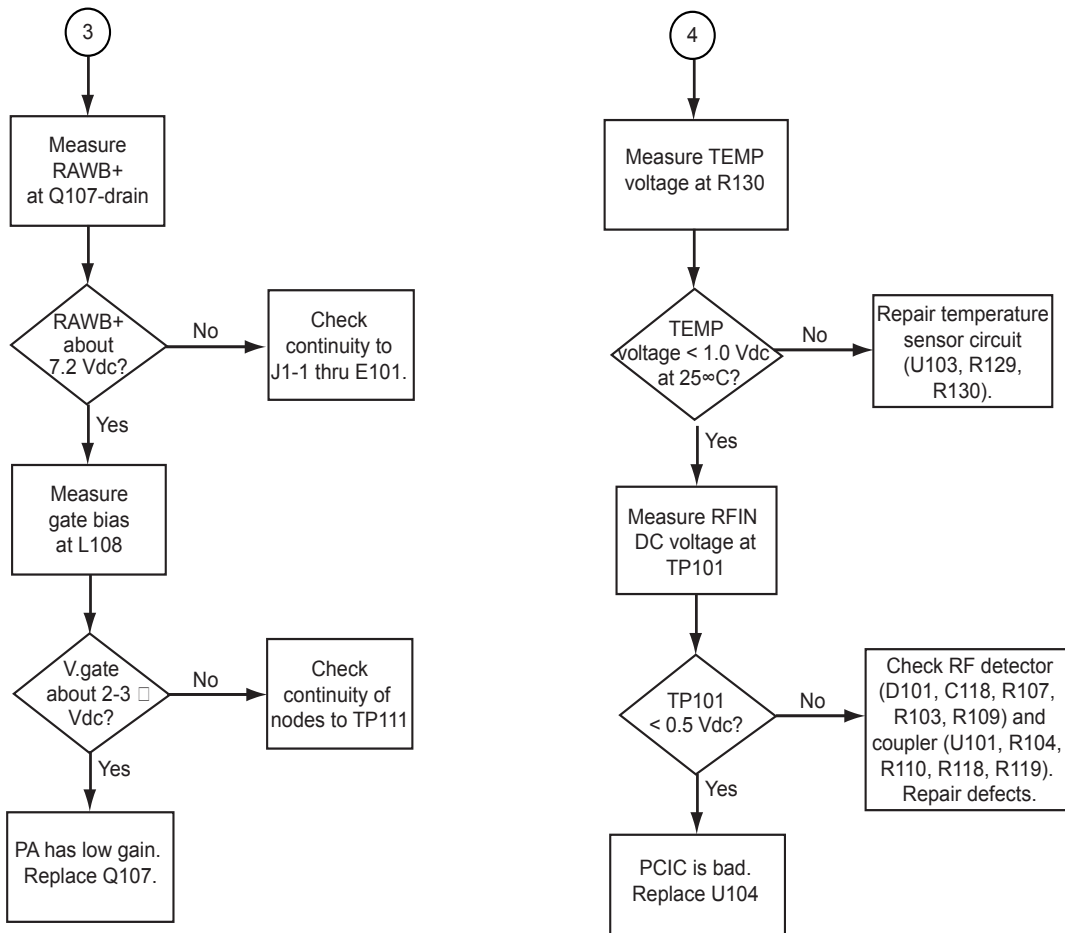
MAEPF-27475-B

TX RF—Page 2

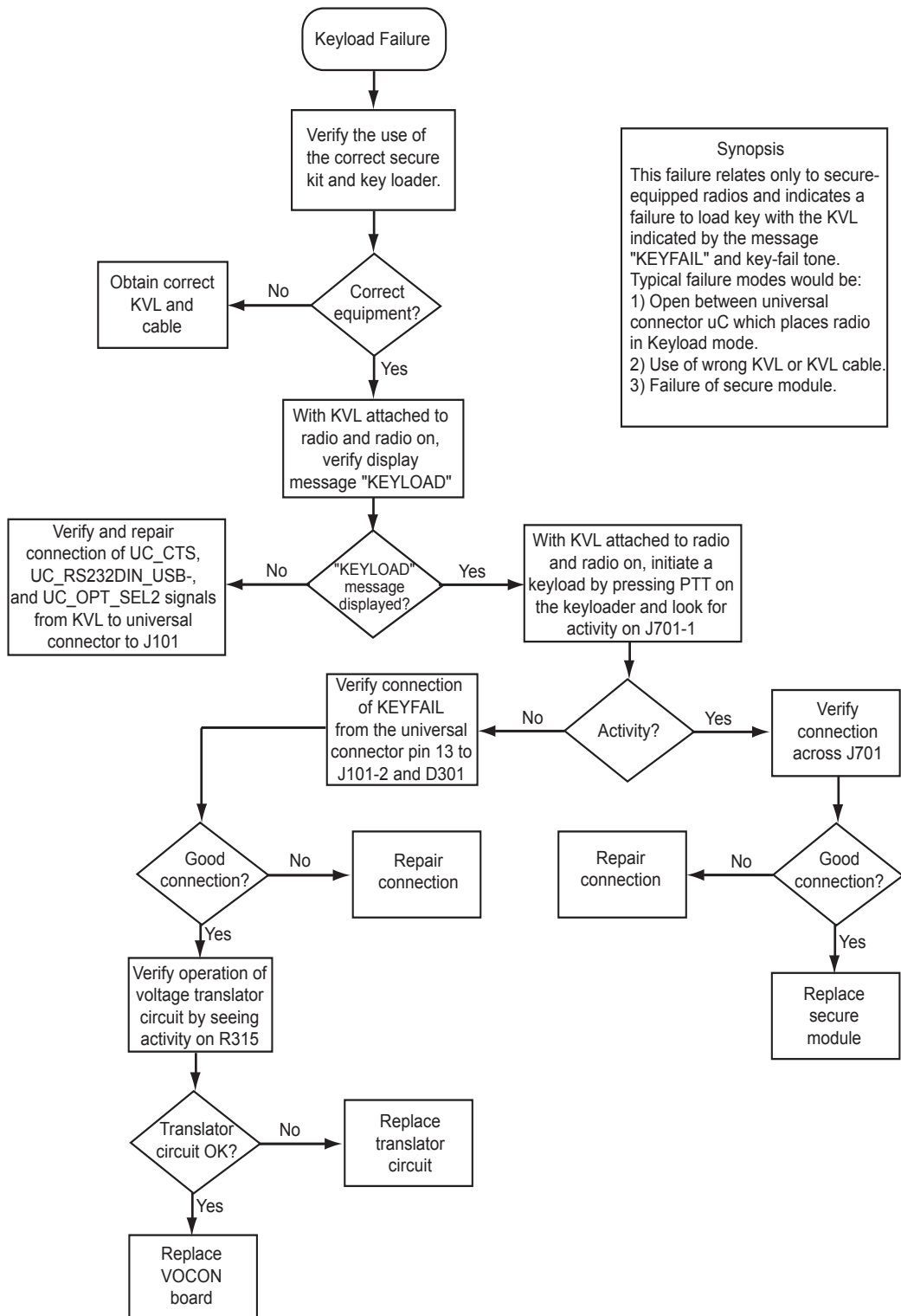


MAEPF-27420-B

TX RF—Page 3



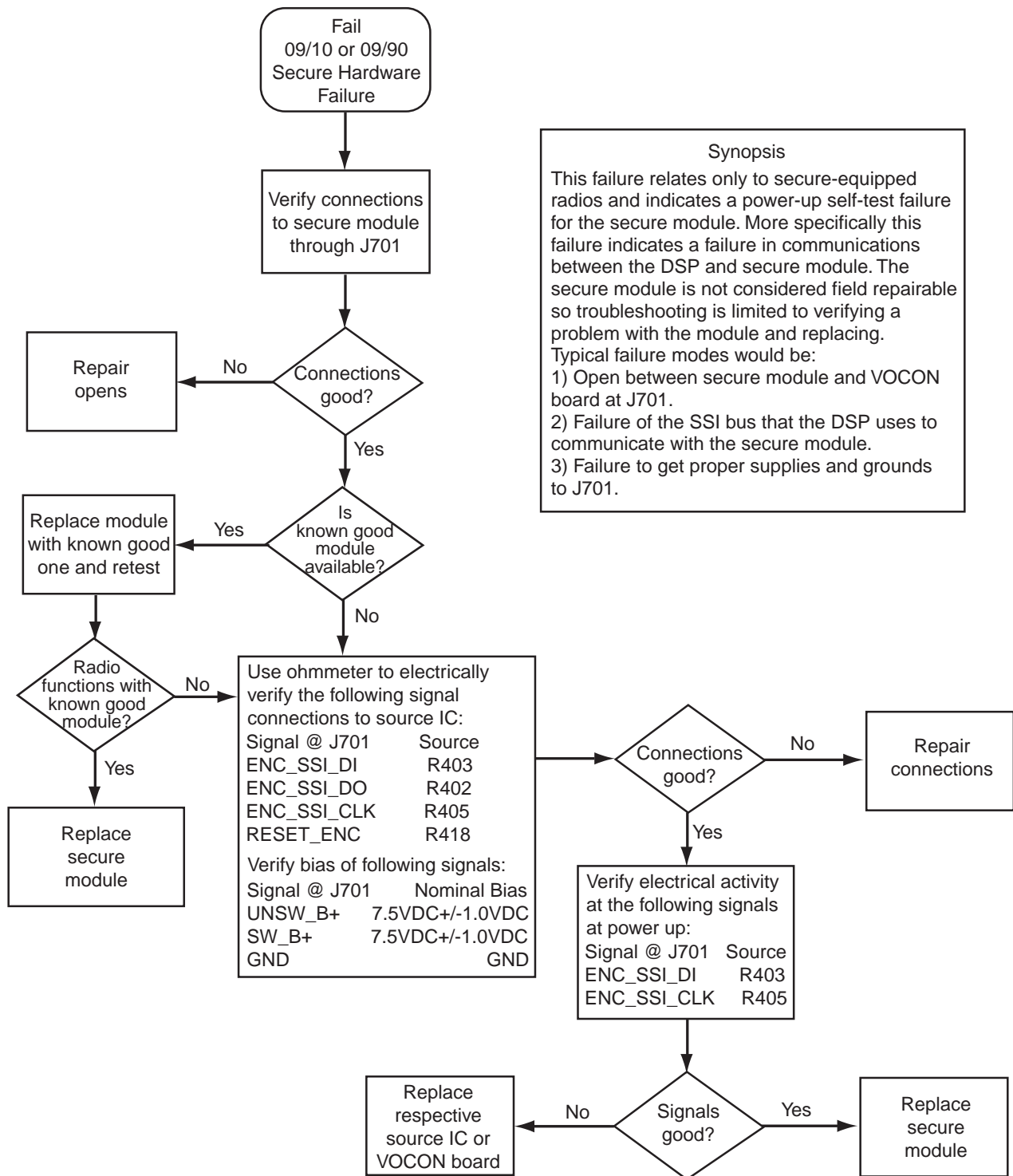
9.15 Keyload Failure



Synopsis
 This failure relates only to secure-equipped radios and indicates a failure to load key with the KVL indicated by the message "KEYFAIL" and key-fail tone. Typical failure modes would be:
 1) Open between universal connector uC which places radio in Keyload mode.
 2) Use of wrong KVL or KVL cable.
 3) Failure of secure module.

MAEPF-27388-B

9.16 Secure Hardware Failure



Synopsis

This failure relates only to secure-equipped radios and indicates a power-up self-test failure for the secure module. More specifically this failure indicates a failure in communications between the DSP and secure module. The secure module is not considered field repairable so troubleshooting is limited to verifying a problem with the module and replacing. Typical failure modes would be:

- 1) Open between secure module and VOCON board at J701.
- 2) Failure of the SSI bus that the DSP uses to communicate with the secure module.
- 3) Failure to get proper supplies and grounds to J701.

MAEPF-27387-O

Notes

Chapter 10 Troubleshooting Tables

10.1 List of Board and IC Signals

Due to the nature of the schematic-generating program, signal names might be different when they are not directly connected to the same point. The tables in this chapter provide a cross reference to the various pinouts for these signals. [Table 10-1](#) lists and provides links to each of the tables in this chapter.

Table 10-1. List of Tables of Board and IC Signals

Table No.	Table Name	Page No.
10-2	J102 VOCON Board to Universal Flex	10-2
10-3	J707 VOCON Board to Controls Flex Assembly	10-2
10-4	J701 VOCON Board to Encryption Module	10-3
10-5	U402 FLASH Pinouts	10-4
10-6	U403 SRAM Pinouts	10-6
10-7	U401 MCU/DSP IC Pinouts	10-8
10-8	U301 Digital-Support IC Pinouts	10-17
10-9	U501 GCAP II IC Pinouts	10-19

Table 10-2. J102 VOCON Board to Universal Flex

J102 Pin No.	Description	Probe Point	Side Connector Number
1			
2	NO CONNECT		NONE
3	UC_SB9600_BUSY	R242	6
4	BAT_STATUS	NA	NA
5	UC_RTS_KEYFAIL	R248	9
6	UC_EXT_SPKR	VR201, pin 1	2
7	UC_OPTB+_VPP	R255	8
8	UC_EXT_SPKR_NEG	VR201, pin 3	1
9	UC_RS232DIN_USB-	R253	12
10	UC_EXT_MIC	L207	4
11	UC_RS232DOUT_USB+	R252	11
12	UC_OPT_SEL1	R217	7
13	UC_CTS	R245	
14	ONE_WIRE	R218	10

Table 10-3. J707 VOCON Board to Controls Flex Assembly

J707 Pin No.	Description	To/From
1	GND	NA
2	GND	NA
3	UC_DISP_PSH	R259
4	BSSENS_1	L202
5	V2A	L203
6	UNSW_B+	L201
7	UC_TG1	R224
8	V2A	L203
9	GND	NA
10	UC_VOLUME	R249
11	UC_MONITOR	R233

Table 10-3. J707 VOCON Board to Controls Flex Assembly (Continued)

J707 Pin No.	Description	To/From
12	GND	NA
13	UC_INT_PTT	R216
14	UC_RTA0	R235
15	UC_SCAN	R256
16	UC_RTA1	R236
17	UC_SEC_CLEAR	R234
18	UC_RTA2	R239
19	GND	NA
20	UC_RTA3	R241

Table 10-4. J701 VOCON Board to Encryption Module

J701 Pin No.	Description	To/From
1	KEYFAIL_LH_BDMDATA	U305, pin 1
2	NO CONNECT	
3	NO CONNECT	
4	NO CONNECT	
5	NO CONNECT	
6	NO CONNECT	
7	SW_B+	C101
8	NO CONNECT	
9	NO CONNECT	
10	NO CONNECT	
11	NO CONNECT	
12	NO CONNECT	
13	NO CONNECT	
14	NO CONNECT	
15	BOOT_ENC	U401
16	NO CONNECT	
17	NO CONNECT	
18	NO CONNECT	

Table 10-4. J701 VOCON Board to Encryption Module (Continued)

J701 Pin No.	Description	To/From
19	NO CONNECT	
20	NO CONNECT	
21	NO CONNECT	
22	NO CONNECT	
23	NO CONNECT	
24	NO CONNECT	
25	NO CONNECT	
26	WAKEUP	U401
27	NO CONNECT	
28	UCM_SSI_ENC	U301
29	NO CONNECT	
30	RESET_ENC	U401
31	NO CONNECT	
32	SPARE1_ENC	U401
33	GND	
34	SPARE2_ENC	U401
35	NO CONNECT	
36	UNSW_B+	C102
37	ENC_SSI_CLK	U301
38	NO CONNECT	
39	ENC_SSI_DI	U401
40	ENC_SSI_DO	U401

Table 10-5. U402 FLASH Pinouts

U402 Pin No.	Description	To/From	Comment	Accessible on Vocon?
B4	B_CLK	B_CLK**		Yes
E7	CS0	CS0	Active Low	Yes
F8	EN_OE			No
C5	EN_WE			No
D6	WRITE PROTECT			No

Table 10-5. U402 FLASH Pinouts (Continued)

U402 Pin No.	Description	To/From	Comment	Accessible on Vocon?
C4	ADV	ADV**		Yes
B5	RESET	D401, pin 2	1.875 V	Yes
E8	ADDRESS 1			No
D8	ADDRESS 2			No
C8	ADDRESS 3			No
B8	ADDRESS 4			No
A8	ADDRESS 5			No
B7	ADDRESS 6			No
A7	ADDRESS 7			No
C7	ADDRESS 8			No
A2	ADDRESS 9			No
B2	ADDRESS 10			No
C2	ADDRESS 11			No
A1	ADDRESS 12			No
B1	ADDRESS 13			No
C1	ADDRESS 14			No
D2	ADDRESS 15			No
D1	ADDRESS 16			No
D4	ADDRESS 17			No
B6	ADDRESS 18			No
A6	ADDRESS 19			No
C6	ADDRESS 20			No
B3	ADDRESS 21			No
C3	ADDRESS 22			No
D7	ADDRESS 23	R427*		Yes
A3	GROUND			No
F1	GROUND			No
G2	GROUND			No
G8	GROUND			No
E2	DATA 15			No
F2	DATA 14			No

Table 10-5. U402 FLASH Pinouts (Continued)

U402 Pin No.	Description	To/From	Comment	Accessible on Vocon?
F3	DATA 13			No
D5	DATA 12			No
F4	DATA 11			No
F5	DATA 10			No
F6	DATA 9			No
G7	DATA 8			No
G1	DATA 7	R435**		Yes
E3	DATA 6	R434**		Yes
G3	DATA 5	R433**		Yes
E4	DATA 4	R432**		Yes
G5	DATA 3	R431**		Yes
E5	DATA 2	R430**		Yes
E6	DATA 1	R429**		Yes
F7	DATA 0	R428**		Yes
A5	VPP	D402, pin 3	1.875 V	Yes
G6	VSW2	C409*	1.875 V	Yes
E1	VSW2	C409*	1.875 V	Yes
G4	VSW2	C409*	1.875 V	Yes
A4	VSW2	C409*	1.875 V	Yes

* Component located under a shield on the VOCON board

** No test point/component on the VOCON board – signal not accessible

Table 10-6. U403 SRAM Pinouts

U403 Pin No.	Description	To/From	Comment	Accessible on Vocon?
A2	EN_OE			No
G5	R_W	R_W	W = 0 V	Yes
A1	LB			No
B2	UB			No
B5	CS1	CS2 (TP)	Active Low	Yes
A6	CS2	C411*	Active Low	Yes

Table 10-6. U403 SRAM Pinouts (Continued)

U403 Pin No.	Description	To/From	Comment	Accessible on Vocon?
A3	ADDRESS 1			Yes
A4	ADDRESS 2			Yes
A5	ADDRESS 3			Yes
B3	ADDRESS 4			Yes
B4	ADDRESS 5			Yes
C3	ADDRESS 6			Yes
C4	ADDRESS 7			Yes
D4	ADDRESS 8			No
H2	ADDRESS 9			No
H3	ADDRESS 10			No
H4	ADDRESS 11			No
H5	ADDRESS 12			No
G3	ADDRESS 13			No
G4	ADDRESS 14			No
F3	ADDRESS 15			No
F4	ADDRESS 16			No
E4	ADDRESS 17			No
D3	ADDRESS 18			No
H1	ADDRESS 19			No
D1	GROUND			No
E6	GROUND			No
E3	GROUND			No
H6	NOT USED			No
G2	NOT USED			No
G1	DATA 15			No
F1	DATA 14			No
F2	DATA 13			No
E2	DATA 12			No
D2	DATA 11			No
C2	DATA 10			No
C1	DATA 9			No

Table 10-6. U403 SRAM Pinouts (Continued)

U403 Pin No.	Description	To/From	Comment	Accessible on Vocon?
B1	DATA 8			No
G6	DATA 7	R435**		No
F6	DATA 6	R434**		No
F5	DATA 5	R433**		No
E5	DATA 4	R432**		No
D5	DATA 3	R431**		No
C6	DATA 2	R430**		No
C5	DATA 1	R429**		No
B6	DATA 0	R428**		No
D6	VSW2	C411*	1.875 V	Yes
E1	VSW2	C411*	1.875 V	Yes

* Component located under a shield on the VOCON board

** No test point/component on the VOCON board – signal not accessible

Table 10-7. U401 MCU/DSP IC Pinouts

U401 Pin No.	Description	To/From	Comment	Accessible on Vocon?
H10	EEPOT_INC*	C537	Active Low	Yes
J14	EXT_SPKR_SEL	Q505, pin 5		Yes
C14	AUDIO_PA_EN	R575		Yes
B14	HOST_WAKE			No
F6	BATTERY_ID	C556		Yes
E5	MECH_SW_BAR	Q508, pin 3	Active Low	Yes
J6	INT_PTT	R216	Active Low	Yes
J5	GCAP_INT	R538		Yes
J4	OPT_SEL1_IN	U201 pin 1		Yes
J3	UART_INT*			No
C16	8KHZ_INT	R406	8 kHz Pulse	Yes
G11	OPT_SEL2_IN	U202 pin 1		Yes
F1	KP_ROW0	C131		Yes
H4	KP_ROW1	C130		Yes

Table 10-7. U401 MCU/DSP IC Pinouts (Continued)

U401 Pin No.	Description	To/From	Comment	Accessible on Vocon?
H6	KP_ROW2	C129		Yes
G2	KP_ROW3	C128		Yes
G11	KP_ROW4	C127		Yes
G7	KP_ROW5	C126		Yes
H7	KP_ROW6	C125		Yes
H1	SPARE1_ENC	J701, pin 32		Yes
D1	KP_COL0	C134		Yes
G5	KP_COL1	C133		Yes
F3	KP_COL2	C132		Yes
G4	ENC_RESET	J701, pin 30		Yes
F2	BOOT*	J701, pin 15		Yes
E1	WAKEUP	J701, pin 26		Yes
H6	SPARE2_ENC	J701, pin 34		Yes
G3	NOT USED			No
E7	NOT USED			No
A8	NOT USED			No
F8	MISOA_SEL	U406, pin 2		Yes
E8	NOT USED			No
G8	NOT USED			No
C3	NOT USED			No
D4	LOCK_DET	C123	Active Low	Yes
A2	TG2	R234		Yes
B2	RTA3	R241		Yes
A3	RTA2	R239		Yes
B3	RTA1	R236		Yes
B4	RTA0	R235		Yes
A7	VSW2	E401*	1.875 V	Yes
P3	VSW2	E401*	1.875 V	Yes
P6	VSW2	E401*	1.875 V	Yes
T9	VSW2	E401*	1.875 V	Yes
N10	VSW2	E401*	1.875 V	Yes

Table 10-7. U401 MCU/DSP IC Pinouts (Continued)

U401 Pin No.	Description	To/From	Comment	Accessible on Vocon?
R16	VSW2	E401*	1.875 V	Yes
H9	V2	E402*	3.0 V	Yes
G9	V2	E402*	3.0 V	Yes
E15	V2	E402*	3.0 V	Yes
A16	V2	E402*	3.0 V	Yes
K10	V2	E402*	3.0 V	Yes
C12	V2	E402*	3.0 V	Yes
D8	V2	E402*	3.0 V	Yes
B7	V2	E402*	3.0 V	Yes
A4	V2	E402*	3.0 V	Yes
A16	V2	E402*	3.0 V	Yes
H2	V2	E402*	3.0 V	Yes
K3	VSW2	E401*	1.875 V	Yes
R8	VSW2	E401*	1.875 V	Yes
G15	VSW2	E401*	1.875 V	Yes
C10	VSW2	E401*	1.875 V	Yes
K12	URXD1_USB_VMI			No
L16	URTS1_XRXD			No
F13	ADTRIG			No
B16	URXD2	U303, pin 4		Yes
D14	BSY_IN_RTS			No
B12	RX_SSI_DATA	R123	Data From Abacus to DSP	Yes
C11	TX_SSI_CLK	R125	1.536 MHz	Yes
B10	RED_LED	Q201, pin 3	Active High	Yes
D10	GREEN_LED	Q201, pin 5	Active High	Yes
B11	TX_SSI_FSYNC	R119	48 kHz	Yes
J10	CODEC_TX	R402	GCAP to DSP Tx Audio Data	Yes
J15	CODEC_DCLK	R405	256 kHz	Yes
K16	CODEC_FSYNC	R406	8 kHz Pulse	Yes

Table 10-7. U401 MCU/DSP IC Pinouts (Continued)

U401 Pin No.	Description	To/From	Comment	Accessible on Vocon?
D7	SPI_MISOA	MISOA	SPI A Data In	Yes
D3	SPI_MISOB	MISOB	SPI B Data In	Yes
E6	NOT USED			No
F7	NOT USED			No
D6	EEPROM_SEL*	R132	Active Low	Yes
C5	AD_CS*	R133	Active Low	Yes
A9	NOT USED			No
B8	NOT USED			No
B9	NOT USED			No
A10	NOT USED			No
G6	BT_DISABLE			No
D13	NOT USED			No
S15	BT_WAKE			No
F11	RX_SSI_CLK	R124		Yes
B15	OPT_SEL2_OUT	R256		Yes
J13	AUDIO_MODE_SEL	R257		Yes
J16	EEPOT_CS_EXT*	U509, pin 1		Yes
J12	EEPOT_U_D*	U509, pin 2		Yes
H11	EEPOT_CS*	U509, pin 10		Yes
A5	GROUND	GROUND		Yes
N6	GROUND	GROUND		Yes
P8	GROUND	GROUND		Yes
P11	GROUND	GROUND		Yes
M11	GROUND	GROUND		Yes
L15	GROUND	GROUND		Yes
H16	GROUND	GROUND		Yes
F14	GROUND	GROUND		Yes
G14	GROUND	GROUND		Yes
E13	GROUND	GROUND		Yes
B13	GROUND	GROUND		Yes
K15	GROUND	GROUND		Yes

Table 10-7. U401 MCU/DSP IC Pinouts (Continued)

U401 Pin No.	Description	To/From	Comment	Accessible on Vocon?
D9	GROUND	GROUND		Yes
C8	GROUND	GROUND		Yes
B5	GROUND	GROUND		Yes
C2	GROUND	GROUND		Yes
C1	GROUND	GROUND		Yes
H3	GROUND	GROUND		Yes
K15	GROUND	GROUND		Yes
T8	GROUND	GROUND		Yes
H15	GROUND	GROUND		Yes
C9	GROUND	GROUND		Yes
B6	ABACUS_CS*	R126	Active Low	Yes
E2	UNI_SEL*	R131	Active Low	Yes
D2	FLPR_CS*		Active Low	No
E3	GCAP_CE	R539	Active High	Yes
E4	SCKB	SCKB	SPI B Clock	Yes
B1	NOT USED			No
F4	NOT USED			No
F5	SPI_MOSIB	MOSIB	SPI Data Out	Yes
C7	SCKA	SCKA	SPI A Clock	Yes
C6	MOSIA	MOSIA	SPI Data Out	Yes
G10	NOT USED			No
G16	OPT_SEL1_OUT	U201, pin 3		Yes
J11	CODEC_RX	R403	DSP to GCAP Rx Audio Data	Yes
A12	RX_SSI_FSYNC	R123	20 kHz pulse	Yes
A11	RX_SSI_CLK	R124	1.2 MHz	Yes
E9	TX_SSI_DATA	R127	Data From DSP to A/D	Yes
C15	BSY_OUT_CTS*			No
F12	UTXD2	U303, pin 1*		Yes
D15	USB_SUSP			No
E14	DISPLAY_R_W*	D403, pin 3	W = 0 V	Yes

Table 10-7. U401 MCU/DSP IC Pinouts (Continued)

U401 Pin No.	Description	To/From	Comment	Accessible on Vocon?
D16	NOT USED			No
G12	UCTS1_USB_SPEED*			No
K11	UTXD1_USB_VPO			No
K14	USB_VMO			No
K13	USB_TX_EN			No
D5	8 KHZ_INT	R406	8 kHz Pulse	Yes
H14	BL_EN	C124		Yes
K4	LV_DETECT	POR	3.0 V	Yes
F9	NOT USED			No
J2	NOT USED			No
A6	16_8_MHZ	C452*	16.8 MHz	Yes
J7	FLIP_32K	U302, pin 2*	32.768 kHz	Yes
G13	NOT USED			No
J11	MOD	MOD	Bootstrap mode > 2.7 V	Yes
A13	NOT USED			No
M6	NOT USED			No
R1	NOT USED			No
N3	NOT USED			No
M5	NOT USED			No
P2	NOT USED			No
P1	NOT USED			No
N1	NOT USED			No
M4	NOT USED			No
M3	NOT USED			No
M2	NOT USED			No
M1	NOT USED			No
L4	NOT USED			No
L3	NOT USED			No
L1	NOT USED			No
L2	NOT USED			No

Table 10-7. U401 MCU/DSP IC Pinouts (Continued)

U401 Pin No.	Description	To/From	Comment	Accessible on Vocon?
K2	NOT USED			No
T1	NOT USED			No
R2	NOT USED			No
T2	NOT USED			No
K7	NOT USED			No
N2	NOT USED			No
L5	NOT USED			No
L6	NOT USED			No
C4	NOT USED			No
L13	NOT USED			No
D11	ONE_WIRE_EN*		Active Low	No
E16	KVL_USB_DET*		Active Low	No
F15	NOT USED			No
K5	BAT_BUS_EN*	Q507, pin 2	Active Low	Yes
H8	NOT USED			No
F16	RESET	D401, Pin 3	Reset = 0 V	Yes
K6	USB_VPI			No
H12	BL_FREQ	Q202, pin 5	Active High	Yes
H13	NOT USED			No
E10	DSP_DE	DSP_DE	ONCE/JTAG	Yes
F10	MCU_DE	MCU_DE	ONCE/JTAG	Yes
D12	TCK	TCK	ONCE/JTAG	Yes
C13	TMS	TMS	ONCE/JTAG	Yes
E11	TRST	TRST	ONCE/JTAG	Yes
A14	TDO	TDO	ONCE/JTAG	Yes
E12	TDI	TDI	ONCE/JTAG	Yes
M16	NOT USED			No
L14	NOT USED			No
P15	NOT USED			No
L11	NOT USED			No
M14	NOT USED			No

Table 10-7. U401 MCU/DSP IC Pinouts (Continued)

U401 Pin No.	Description	To/From	Comment	Accessible on Vocon?
N16	NOT USED			No
L12	NOT USED			No
M12	CKO	CKO	Disabled	Yes
N15	NOT USED			No
M15	NOT USED			No
R12	ADDRESS 0	J101, pin 7	Not accessible	Yes
T13	ADDRESS 1			No
M10	ADDRESS 2			No
T12	ADDRESS 3			No
P13	ADDRESS 4			No
M9	ADDRESS 5			No
P10	ADDRESS 6			No
P12	ADDRESS 7			No
N9	ADDRESS 8			No
R10	ADDRESS 9			No
P9	ADDRESS 10			No
L10	ADDRESS 11			No
T10	ADDRESS 12			No
R9	ADDRESS 13			No
L9	ADDRESS 14			No
K9	ADDRESS 15			No
J9	ADDRESS 16			No
L8	ADDRESS 17			No
M8	ADDRESS 18			No
N8	ADDRESS 19			No
K8	ADDRESS 20			No
L7	ADDRESS 21			No
T7	ADDRESS 22			No
R7	ADDRESS 23	R427*		Yes
R3	DATA 15			No
T3	DATA 14			No

Table 10-7. U401 MCU/DSP IC Pinouts (Continued)

U401 Pin No.	Description	To/From	Comment	Accessible on Vocon?
N4	DATA 13			No
P4	DATA 12			No
R4	DATA 11			No
J8	DATA 10			No
T4	DATA 9			No
N5	DATA 8			No
P5	DATA 7	R435**		Yes
R5	DATA 6	R434**		Yes
T5	DATA 5	R433**		Yes
R6	DATA 4	R432**		Yes
T6	DATA 3	R431**		Yes
M7	DATA 2	R430**		Yes
N7	DATA 1	R429**		Yes
P7	DATA 0	R428**		Yes
N11	R_W	R_W		Yes
T11	NOT USED			No
R14	NOT USED			No
N12	CS3*	R106**	Active Low	Yes
T14	CS2	CS2	Active Low	Yes
R11	NOT USED			No
R15	CS0	CS0	Active Low	Yes
P16	OE_EN			No
M13	EB1_N			No
R13	EBO_N			No
N14	NOT USED			No
T16	WAIT	WAIT**		Yes
P14	NOT USED			No
N13	ADV	ADV**		Yes
T15	B_CLK	B_CLK**		Yes

* Component located under a shield on the VOCON board

** No test point/component on the VOCON board – signal not accessible

Table 10-8. U301 Digital-Support IC Pinouts

U301 Pin No.	Description	To/From	Comment	Accessible on Vocon?
E7	RXDIN_ENC_3V	R308		Yes
D5	TXDO_BDI_5V	R329*	5 V RS232 Data Out	Yes
C7	RXDIN_5V	R328*	5 V RS232 Data In	Yes
A8	RTS	D303 pin 3	Request to Send (RS232)	Yes
D7	CTS	R303	Clear to Send (RS232)	Yes
H8	CTS_FILLREQ_3V	R306**		Yes
H3	16.8 MHz	C307*	16.8 MHz Clock	Yes
H6	13 MHz	R302 R331*	13 MHz Clock (OUT)	Yes
H5	PLL_LFT	C302*	PLL Loop Filter	Yes
F4	CODEC_DCLK	R405	520 kHz	Yes
E5	CODEC_FSYNC	R406	8 kHz Pulse	Yes
G4	UCM_SS	J701 pin 28		Yes
G2	V2	C304*	3.0 V	Yes
F1	V2	C317*	3.0 V	Yes
F3	VSS3_DC	GROUND		Yes
F2	VSS3_AC	GROUND		Yes
D8	VCC5	C305*	5.0 V	Yes
C8	VSS5	GROUND		Yes
A7	LI_CELL	C312*	3.0-3.3 V	Yes
C6	VSS3_XTL	GROUND		Yes
A4	UART_TX	NC		No
C4	UART_RX	NC		No
G3	ONE_WIRE_UP			No
G7	KVL_USB_DET			No
G1	ONE_WIRE_EN*			No
B5	BSY_IN_RTS			No
C5	BSY_OUT_CTS			No
E4	UCTS1_USB_SPEED*			No
C1	USB_TXENAB			No

Table 10-8. U301 Digital-Support IC Pinouts (Continued)

U301 Pin No.	Description	To/From	Comment	Accessible on Vocon?
D1	UTXD1_USP_VPO			No
B1	USB_VMO			No
C3	URTS1_XRXD			No
C2	USB_VPI			No
D2	URXD1_USB_VMI			No
E3	USB_SUSP			No
B2	SCKB	SCKB	SPI B Clock	Yes
B3	SPI_MOSIB	MOSIB	SPI Data Write to Flipper IC	Yes
A2	SPI_MISOB	MISOA	SPI Data Read from Flipper IC	Yes
A1	FLPR_CS*			No
A3	UART_INT*			No
F5	GCAP_RESET_X	C310*		Yes
H4	TEST_MODE1	GROUND		Yes
H1	TES_MODE2	GROUND		Yes
G6	OUT_DIS	GROUND		Yes
G5	SCAN_EN	GROUND		Yes
A6	XTAL32_IN			Yes
B6	XTAL32_OUT			Yes
A5	REF32_OUT	R316	32.768 kHz Square Wave	Yes
B7	BYPASS_32	GROUND		Yes
B4	BP_SEN_X	R510	0 V	Yes
D4	WD_OUT	R528	Watchdog Int to GCAP II	Yes
H2	ONE_WIRE_OPT	D306 pin 3		Yes
D6	SB96D_BDO_KF_5V	NC		No
B8	LH_BUSY	D307 pin 3		Yes
D3	USB_DIS	R310*		Yes
E2	USB_DPLUS	Q301 pin 1*	USB Data Plus	Yes
E1	USB_DMINUS	Q301 pin 4*	USB Data Minus	Yes
E8	SB96D_BDO_KF_3V	NC		No
F6	SB96D_BDO_3V	D308 pin 3		Yes

Table 10-8. U301 Digital-Support IC Pinouts (Continued)

U301 Pin No.	Description	To/From	Comment	Accessible on Vocon?
H7	RTS_FILLSEN_3V	NC		No
G8	CTS_FILLREQ_3V	R309*		Yes
F8	TXDO_BDI_ENC_3V	R317		Yes
F7	TXDO_BDI_UP_3V	R317		Yes
E6	RXDIN_ENC_3V	R308		Yes

* Component located under a shield on the VOCON board

** No test point/component on the VOCON board – signal not accessible

Table 10-9. U501 GCAP II IC Pinouts

U501 Pin No.	Description	To/From	Comment	Accessible on Vocon?
A2	AD4_BD_ID	R525		Yes
B2	AD3_BDTYPE	R524		Yes
B3	AD2_BAT_STAT	R568		Yes
A3	AD_TG1	R523		Yes
D4	AD0_EMERG	R522		Yes
C4	LV_DETECT	R511	Active Low	Yes
B4	AD_TRIG			No
A4	CONV_BYP	C516		Yes
B5	V3	C550	Unused Voltage Regulator	Yes
A5	VIN3	C515	3.77 V	Yes
D5	VSEN1	GROUND	0 V	Yes
C5	VSIN	C515	3.77 V	Yes
C6	VSIM1	C551	Unused Voltage Regulator	Yes
A6	V1	C552	Unused Voltage Regulator	Yes
B6	VIN1	B503	7.5V	Yes
D6	LI_CELL	C553	3.0-3.3V	Yes
D7	CHARGE	NC		No

Table 10-9. U501 GCAP II IC Pinouts (Continued)

U501 Pin No.	Description	To/From	Comment	Accessible on Vocon?
A7	XTAL1	G_32K	32.768 kHz Square Wave	Yes
B7	XTAL2			No
A8	PRSC2	C514	3.77V	Yes
B8	LX2	D502	262.144 kHz Square Wave	Yes
A9	PGND1	GROUND		Yes
B9	FB2	R501	1.85V	Yes
C8	ON	R579		Yes
A10	FB1	R502	3.77V	Yes
B10	LX1	D503	262.144 kHz Square Wave	Yes
C9	PWRON	C529	At Battery Voltage Level	Yes
D8	INT_EXT	GROUND		Yes
C10	PSRC1	C531	At Battery Voltage Level	Yes
E7	WDI	R576	3.0V	Yes
D10	MOSPORTB	C529	At Battery Voltage Level	Yes
D9	ISENSE	NC		No
E8	CHRG_C	NC		No
E9	SQ_OUT	NC		No
E10	BPOS	C529	At Battery Voltage Level	Yes
F7	BATTERY	NC		No
F8	AUX_BAT	NC		No
F9	AUX_FET	NC		No
F10	MAIN_FET	NC		No
E6	PGM2	C529	At Battery Voltage Level	Yes
G8	PGM1	C529	At Battery Voltage Level	Yes
G10	AGND1	GROUND		Yes
G9	REF	C528	3.0V	Yes

Table 10-9. U501 GCAP II IC Pinouts (Continued)

U501 Pin No.	Description	To/From	Comment	Accessible on Vocon?
H9	PA_DRV	NC		No
H10	PA_SENSE	NC		No
G7	PGM0	GROUND		Yes
H8	LS3_RX	NC		No
J10	DGND	GROUND		Yes
K10	LS3TX_PABPOS	GROUND		Yes
K1	MIC_OUT	U509 pin 6	AC Mic Signal	Yes
G4	STANDBY	R557	3.0V	Yes
K2	AUX_OUT	U509 pin 6	AC Mic Signal	Yes
H3	AUX_MIC_NEG	C538	Virtual Ground	Yes
J3	MB_CAP	C535		Yes
H4	EXT_MIC	NC		No
K3	MIC_BIAS	C535		Yes
J4	CD_CAP	C543		Yes
K4	VAG	C544		Yes
J5	V2	R560	3.0V	Yes
K5	VIN2	R502	3.77V	Yes
G5	ON2	NC		No
H5	EXTOUT	C533	AC RX Audio Signal	Yes
K6	SPKR_OUT	NC		No
J6	SPKR_IN	NC		No
H6	SPKR_NEG	NC		No
H7	SPKR_POS	NC		No
K7	LS1IN_TG1A	GROUND		Yes
J7	LS1OUT_TG1	NC		No
G6	LS2IN_TG2A	GROUND		Yes
F6	LS2OUT_TG2			No
K8	ALRT_GND			No
K9	ALRT_OUT	NC		No
J9	ALRT_VCC	NC		No

Table 10-9. U501 GCAP II IC Pinouts (Continued)

U501 Pin No.	Description	To/From	Comment	Accessible on Vocon?
J8	SIMI_O	NC		No
A1	AD5_VOLUME	R526	0-2.5V	Yes
B1	AGND3	GROUND		Yes
C3	DWN_OUT	NC		No
C2	DWN_IN	GROUND		Yes
C1	CMP_OUT	NC		No
D3	DSC_INN	GROUND		Yes
D2	DSC_INP	GROUND		Yes
D1	SPI_CLK	SCKB	SPI Data Clock	Yes
E4	SPI_DR	MISOB	SPI Data Read From GCAP	Yes
E3	SPI_DW	MOSIB	SPI Data Write To GCAP	Yes
E2	SR_VCCIN	NC		No
E1	SR_VCCOUT	NC		No
F3	SR_IN	NC		No
F2	SR_OUT	NC		No
F1	INTERRUPT	R538	GCAP Interrupt	Yes
F4	CE	R539	Active High GCAP Chip EN	Yes
F5	CLK_IN	R302 R331*	13 MHz	Yes
E5	CODEC_DCLK	R405	256 kHz	Yes
G1	CODEC_TX	R402	TX Audio Data To DSP	Yes
G2	CODEC_RX	R403	RX Audio Data From DSP	Yes
G3	CODEC_FSYNC	R406	8 kHz Frame Sync	Yes
H1	AGND4	GROUND		Yes
J1	AGND2	GROUND		Yes
H2	MICIN_POS	C534		Yes

Table 10-9. U501 GCAP II IC Pinouts (Continued)

U501 Pin No.	Description	To/From	Comment	Accessible on Vocon?
J2	MICIN_NEG		Virtual Ground	No

* Component located under a shield on the VOCON board

Notes

Chapter 11 Troubleshooting Waveforms

This chapter contains images of waveforms that might be useful in verifying operation of certain parts of the circuitry. These waveforms are for reference only; the actual data depicted will vary depending on operating conditions.

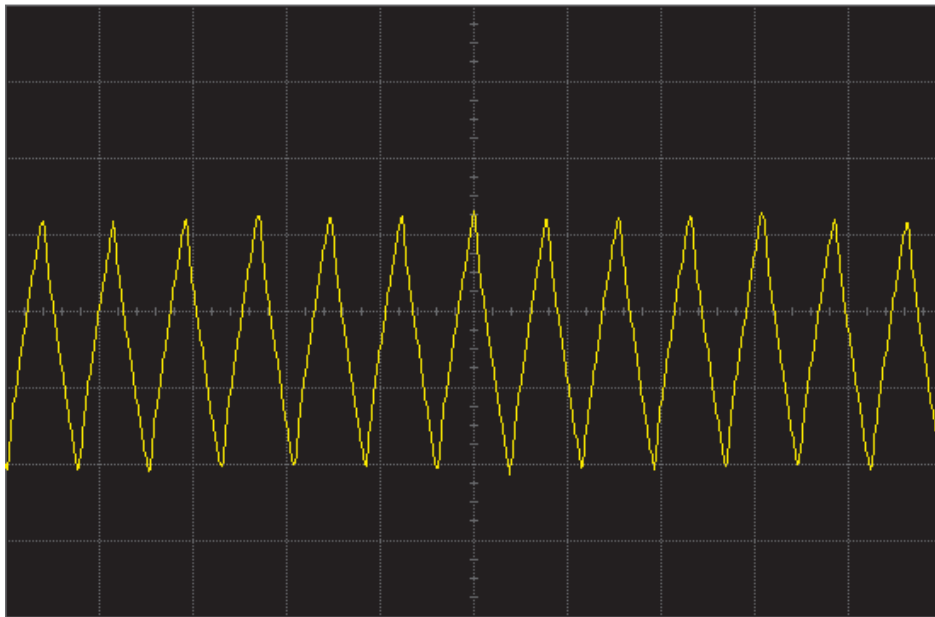
11.1 List of Waveforms

[Table 11-1](#) lists each waveform and the page on which the waveform can be found.

Table 11-1. List of Waveforms

Waveform	Page No.
13 MHz Clock	11-2
16.8 MHz Buffer Input and Output	11-3
32.768 kHz Clock Outputs	11-4
SPI B Data	11-5
Receive Serial Audio Port (SAP)	11-6
Receive Baseband Interface Port (RX BBP)	11-7
Transmit Baseband Interface Port (TX BBP)	11-8

11.2 13 MHz Clock



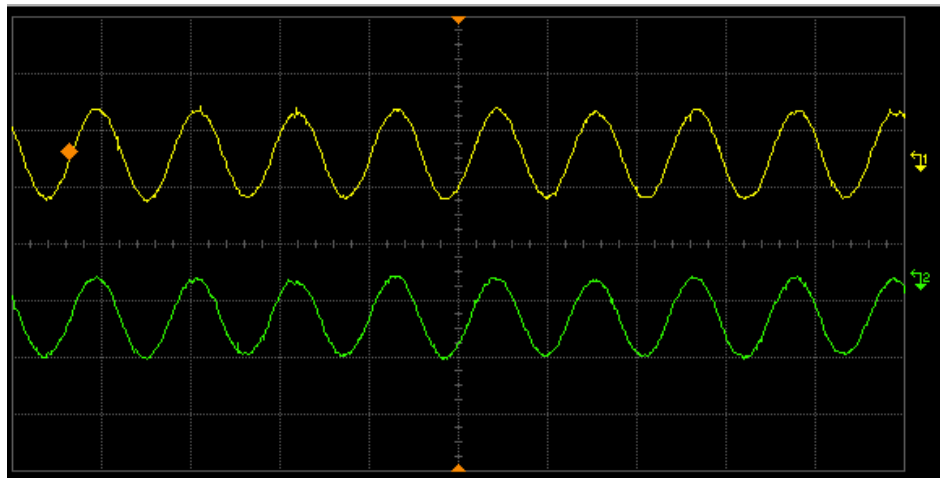
Acquisition	Sampling mode real time Configuration 4GSa/s Memory depth automatic Memory depth 1004pts Sampling rate automatic Sampling rate 1.00 GSa/s Averaging off 9-bit BW Filter off Interpolation on
Channel 1	Scale 200 mV/div Offset 1.604 V Coupling DC Impedance 1M Ohm Attenuation 10.00 : 1 Atten units ratio Skew 0.0 s Ext adapter None Ext coupler None Ext gain 1.00E+00 Ext offset 0.0E+00
Time base	Scale 100 ns/div Position 92.181816 μ s Reference center
Trigger	Mode edge Sweep auto Hysteresis normal Holdoff time 60 ns Coupling DC Source channel 1 Trigger level 1.379 V Slope rising

MAEPF-27490-O

**13 MHz clock from U301 to U501.
Similar waveform is visible on C339 on the VOCON board.**

Figure 11-1. 13 MHz Clock Waveform

11.3 16.8 MHz Buffer Input and Output



Acquisition	Sampling mode real time Configuration 4GSa/s Memory depth automatic Memory depth 1004pts Sampling rate automatic Sampling rate 10.0 kSa/s Averaging off 9-bit B/W Filter off Interpolation on					
Channel 1	Scale 500 mV/div Offset -785 mV Coupling DC Impedance 1M Ohm Attenuation 10.00 : 1 Atten units ratio Skew 0.0 s Ext adapter None Ext coupler None Ext gain 1.00E+00 Ext offset 0.0E+00					
Channel 2	Scale 500 mV/div Offset 263 mV Coupling DC Impedance 1M Ohm Attenuation 10.00 : 1 Atten units ratio Skew 0.0 s Ext adapter None Ext coupler None Ext gain 1.00E+00 Ext offset 0.0E+00					
Channel 3	Scale 2.00 V/div Offset 4.35 V Coupling DC Impedance 1M Ohm Attenuation 10.00 : 1 Atten units ratio Skew 0.0 s Ext adapter None Ext coupler None Ext gain 1.00E+00 Ext offset 0.0E+00					
Time base	Scale 10.0 ms/div Position 0.0 s Reference center					
Trigger	Mode edge Sweep auto Hysteresis normal Holdoff time 60 ns Coupling DC Source channel 3 Trigger level 1.89 V Slope falling					
Measure		current	mean	std dev	min	max
	Frequency(1*)	88.555 Hz	? 88.6408 Hz	? 5.716377 Hz	? 22.4136 Hz	? 91.306 Hz
	V p-p(1)	842 mV	1.0210 V	129.4 mV	707 mV	2.934 V
	V p-p(2)	734 mV	762.5 mV	21.7 mV	729 mV	810 mV

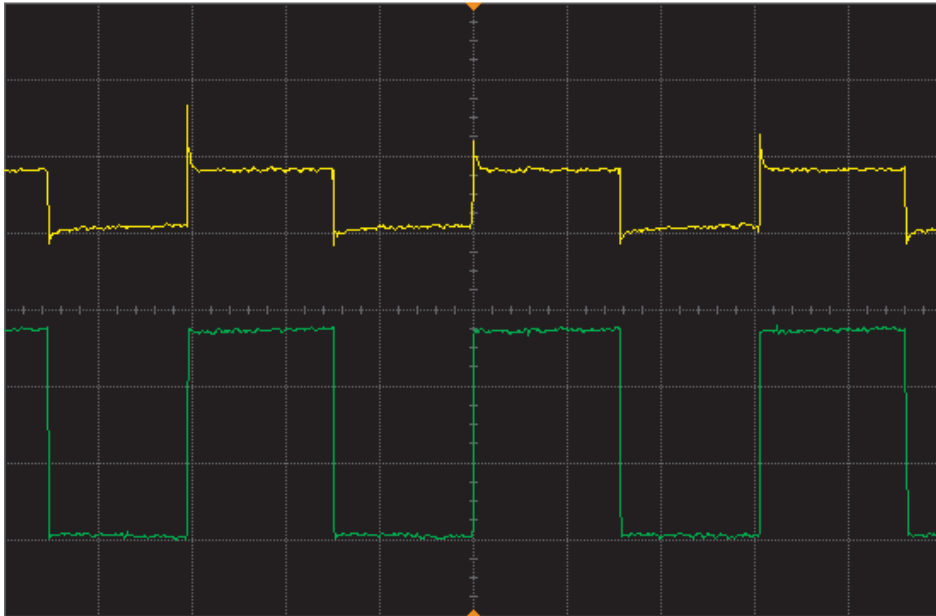
Trace 1: Buffer input at R452.

Trace 2: Buffer output at C452.

Note: These components are under a shield on the VOCON board.

Figure 11-2. 16.8 MHz Buffer Input and Output Waveforms

11.4 32.768 kHz Clock Outputs



Acquisition	Sampling mode real time Configuration 4GSa/s Memory depth automatic Memory depth 1004pts Sampling rate automatic Sampling rate 10.0 MSa/s Averaging off 9-bit BW Filter off Interpolation on
Channel 1	Scale 1.00 V/div Offset -1.58 V Coupling DC Impedance 1M Ohm Attenuation 10.00 : 1 Atten units ratio Skew 0.0 s Ext adapter None Ext coupler None Ext gain 1.00E+00 Ext offset 0.0E+00
Channel 2	Scale 1.00 V/div Offset 2.97 V Coupling DC Impedance 1M Ohm Attenuation 10.00 : 1 Atten units ratio Skew 0.0 s Ext adapter None Ext coupler None Ext gain 1.00E+00 Ext offset 0.0E+00
Time base	Scale 10.0 μs/div Position 0.0 s Reference center
Trigger	Mode edge Sweep auto Hysteresis normal Holdoff time 60 ns Coupling DC Source channel 2 Trigger level 1.400 V Slope rising

MAEPF-27492-O

Trace 1: Output at C313 (to real-time clock of GCAP II IC).
Trace 2: Output at U302, pin 2 (to Patriot IC CKIL input).
Note: These components are under a shield on the VOCON board.

Figure 11-3. 32.768 kHz Clock Outputs Waveforms

11.5 SPI B Data



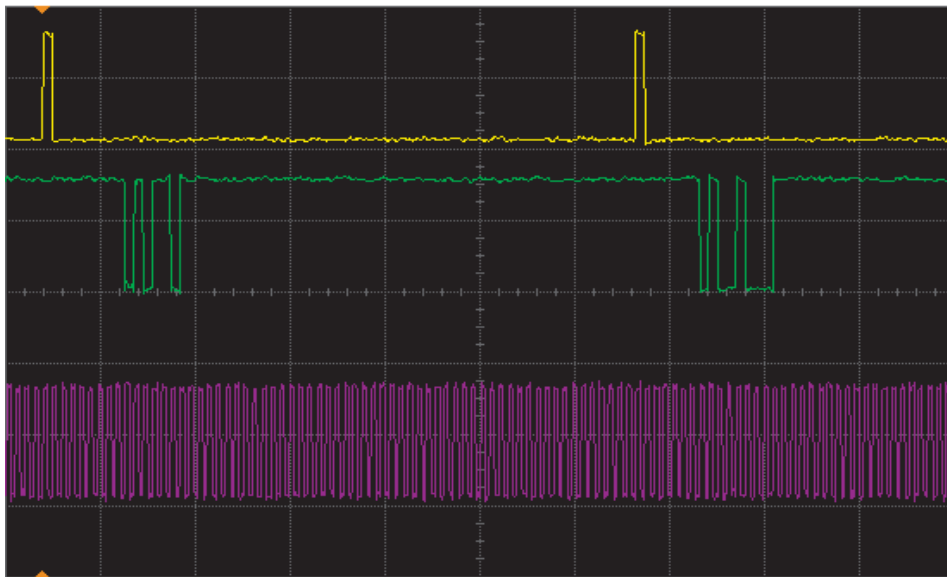
Acquisition	Sampling mode real time Configuration 4GSa/s Memory depth automatic Memory depth 1004pts Sampling rate automatic Sampling rate 50.0 MSa/s Averaging off 9-bit BW Filter off Interpolation on
Channel 1	Scale 1.99 V/div Offset -4.21 V Coupling DC Impedance 1M Ohm Attenuation 10.00 : 1 Atten units ratio Skew 0.0 s Ext adapter None Ext coupler None Ext gain 1.00E+00 Ext offset 0.0E+00
Channel 2	Scale 2.00 V/div Offset -260 mV Coupling DC Impedance 1M Ohm Attenuation 10.00 : 1 Atten units ratio Skew 0.0 s Ext adapter None Ext coupler None Ext gain 1.00E+00 Ext offset 0.0E+00
Channel 3	Scale 2.00 V/div Offset 5.76 V Coupling DC Impedance 1M Ohm Attenuation 10.00 : 1 Atten units ratio Skew 0.0 s Ext adapter None Ext coupler None Ext gain 1.00E+00 Ext offset 0.0E+00
Time base	Scale 2.00 μ s/div Position 3.454546 μ s Reference center
Trigger	Mode edge Sweep auto Hysteresis normal Holdoff time 60 ns Coupling DC Source channel 1 Trigger level 810 mV Slope rising

MAEPF-27493-O

Trace 1: GCAP II IC chip enable at R539 (Note active high).
Trace 2: SPI data clock at Test Point SCKB.
Trace 3: SPI data to GCAP II IC at Test Point MOSIB.

Figure 11-4. SPI B Data Waveforms

11.6 Receive Serial Audio Port (SAP)



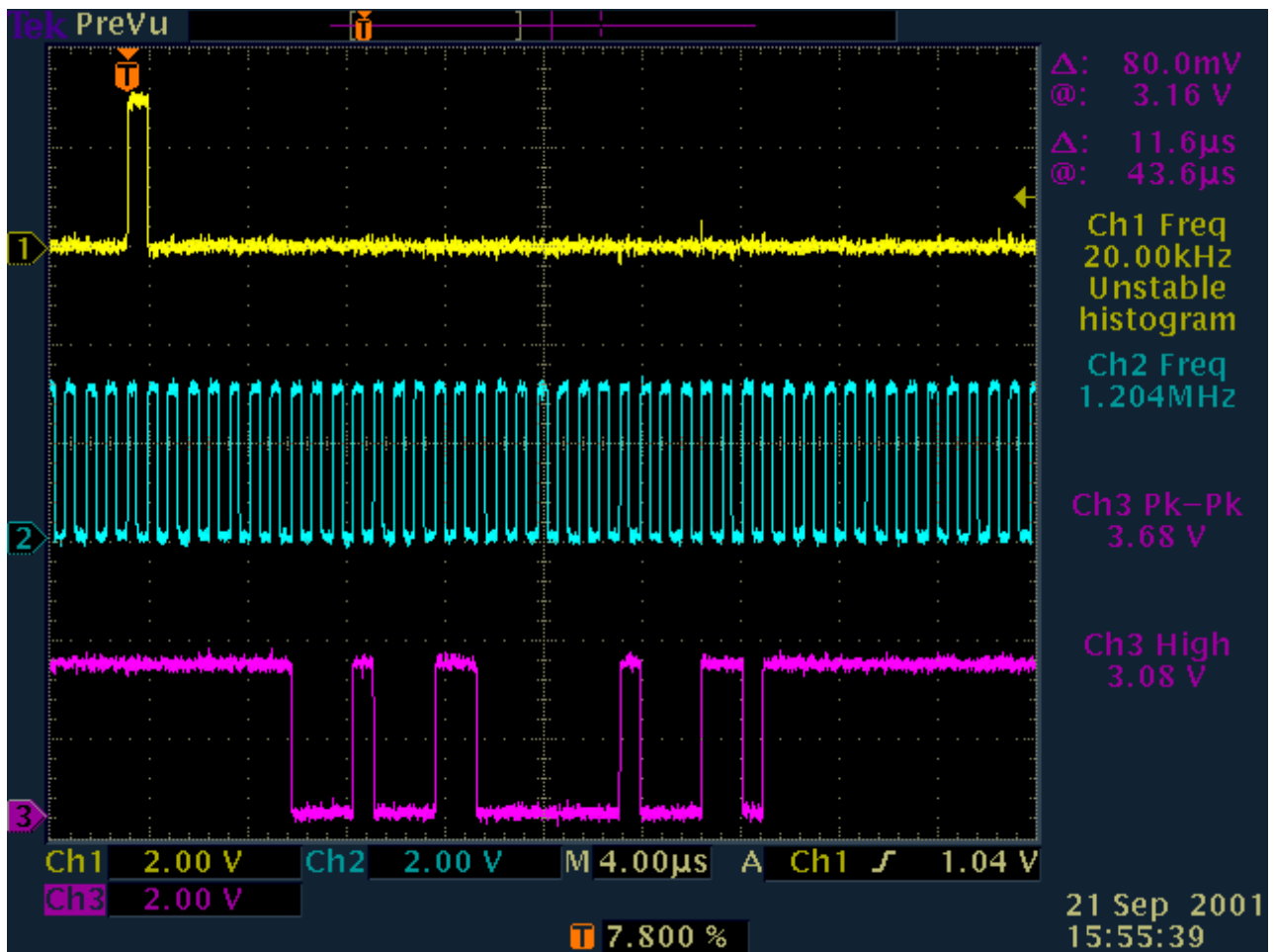
Acquisition	Sampling mode real time Configuration 4GSa/s Memory depth automatic Memory depth 1004pts Sampling rate automatic Sampling rate 5.00 MSa/s Averaging off 9-bit BW Filter off Interpolation on
Channel 1	Scale 1.99 V/div Offset -4.21 V Coupling DC Impedance 1M Ohm Attenuation 10.00 : 1 Atten units ratio Skew 0.0 s Ext adapter None Ext coupler None Ext gain 1.00E+00 Ext offset 0.0E+00
Channel 2	Scale 2.00 V/div Offset -210 mV Coupling DC Impedance 1M Ohm Attenuation 10.00 : 1 Atten units ratio Skew 0.0 s Ext adapter None Ext coupler None Ext gain 1.00E+00 Ext offset 0.0E+00
Channel 3	Scale 2.00 V/div Offset 5.55 V Coupling DC Impedance 1M Ohm Attenuation 10.00 : 1 Atten units ratio Skew 0.0 s Ext adapter None Ext coupler None Ext gain 1.00E+00 Ext offset 0.0E+00
Time base	Scale 20.0 μs/div Position 92.181816 μs Reference center
Trigger	Mode edge Sweep auto Hysteresis normal Holdoff time 60 ns Coupling DC Source channel 1 Trigger level 810 mV Slope rising

MAEPF-27494-O

Trace 1: 8 kHz frame sync at R406 (each word is 13 bits after falling edge of FSYNC).
Trace 2: SAP data at R403 (audio data from GCAP II IC CODEC to Patriot IC DSP).
Note: Transmit is identical, except data acquired at R402.
Trace 3: 256 kHz bit clock at R405 on the VOCON board.

Figure 11-5. Receive Serial Audio Port (SAP) Waveforms

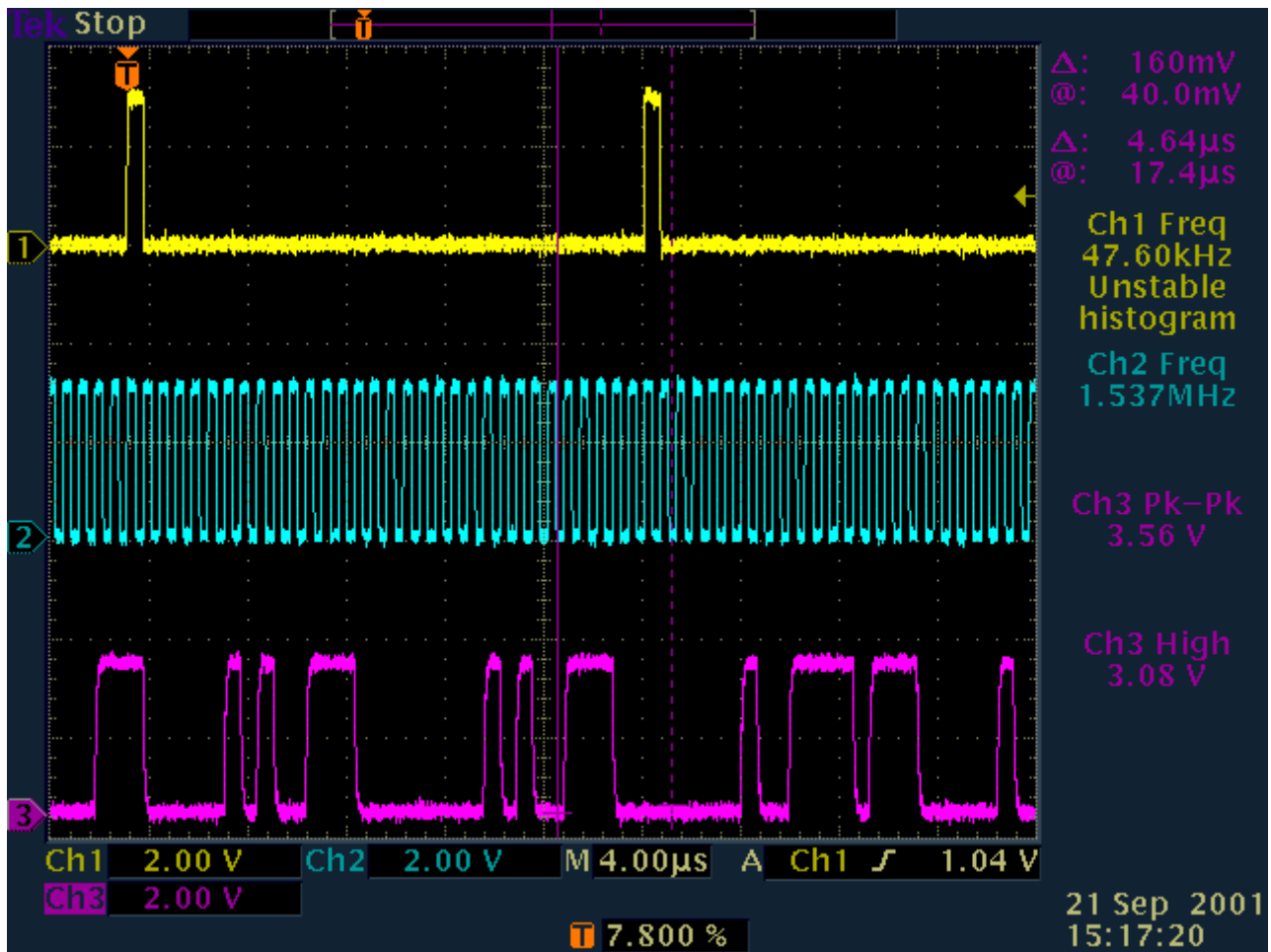
11.7 Receive Baseband Interface Port (RX BBP)



- Trace 1: BBP RX frame sync signal at R123.
- Trace 2: BBP RX clock signal at R124.
- Trace 3: BBP RX data signal at R121.

Figure 11-6. Receive Baseband Interface Port (RX BBP) Waveforms

11.8 Transmit Baseband Interface Port (TX BBP)



Trace 1: BBP TX frame sync signal at R711.

Trace 2: BBP TX clock signal at R715.

Trace 3: BBP TX data signal at R717.

Figure 11-7. Transmit Baseband Interface Port (TX BBP) Waveforms

Chapter 12 Schematics, Board Layouts, and Parts Lists

This chapter contains the schematics, board layouts, and parts lists for the SSE 5000 radio. Use them in conjunction with the theory of operation and the troubleshooting procedures, charts, and waveforms to isolate a problem to the component level.

The following tables list the pages where the schematics, board layouts and parts lists for the SSE 5000 radio are found.

Table 12-1. List of Transceiver Schematics, Board Layouts and Parts Lists

Transceiver Board Schematic/Board Layout/Parts List	Page No.
NUE7337_ Transceiver (RF) Board Overall Circuit Schematic	12-2
NUE7337_ Receiver Front-End Circuit	12-3
NUE7337_ Receiver Back-End Circuit	12-4
NUE7337_ Transmitter and Automatic Level Control Circuits	12-5
NUE7337_ Frequency Generation Unit (Synthesizer) Circuit—1 of 2	12-6
NUE7337_ Frequency Generation Unit (Synthesizer) Circuit—2 of 2	12-7
NUE7337_ DC Power	12-8
NUE7337_ Antenna Switch and Harmonic Filter	12-9
NUE7337_ Transceiver (RF) Board Layout—Side 1	12-10
NUE7337_ Transceiver (RF) Board Layout—Side 2	12-11
NUE7337_ Transceiver (RF) Board Parts List	12-12

Table 12-2. List of VOCON Schematics, Board Layouts and Parts Lists

VOCON Board Schematic/Board Layout/Parts List	Page No.
NCN6186_ VOCON Board Overall Circuit Schematic	12-17
NCN6186_ VOCON Universal Connector Circuit	12-19
NCN6186_ VOCON Flipper Circuit	12-20
NCN6186_ VOCON Controller and Memory Circuits	12-21
NCN6186_ VOCON Audio and DC Circuits	12-23
NCN6186_ VOCON DC Clocks	12-24
NCN6186_ VOCON Display—RF Interface	12-25
NCN6186_ VOCON Spark Gaps	12-26
NCN6186_ VOCON Board Layout—Side 1	12-27
NCN6186_ VOCON Board Layout—Side 2	12-28
NCN6186_ VOCON Board Parts List	12-29

Table 12-3. List of Control Flex Schematics and Board Layouts

Control Flex Schematic/Board Layout	Page No.
Control Flex Overall Circuit Schematic	12-33
Control Flex Board Layout—Side 1	12-34
Control Flex Board Layout—Side 2	12-34

Table 12-4. List of Universal Flex Schematics and Board Layouts

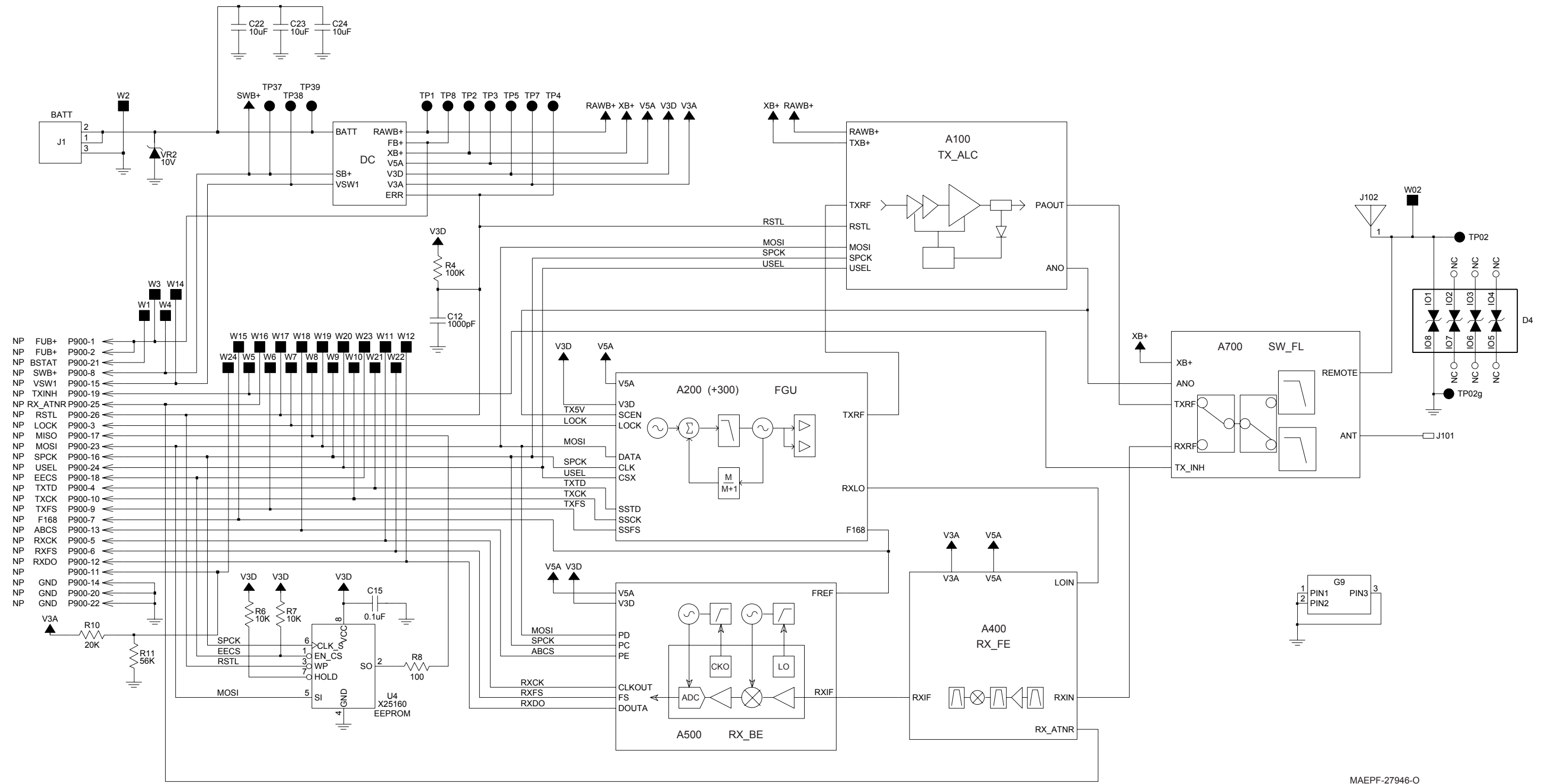
Universal Flex Schematic/Board Layout	Page No.
Universal Flex Overall Circuit Schematic	12-35
Universal Flex Board Layout—Side 1	12-36
Universal Flex Board Layout—Side 2	12-36

Table 12-5. List of UCM Schematics and Board Layouts

UCM Schematic/Board Layout	Page No.
UCM Flex Overall Circuit Schematic	12-37
UCM Board Layout—Side 1	12-38
UCM Board Layout—Side 2	12-38

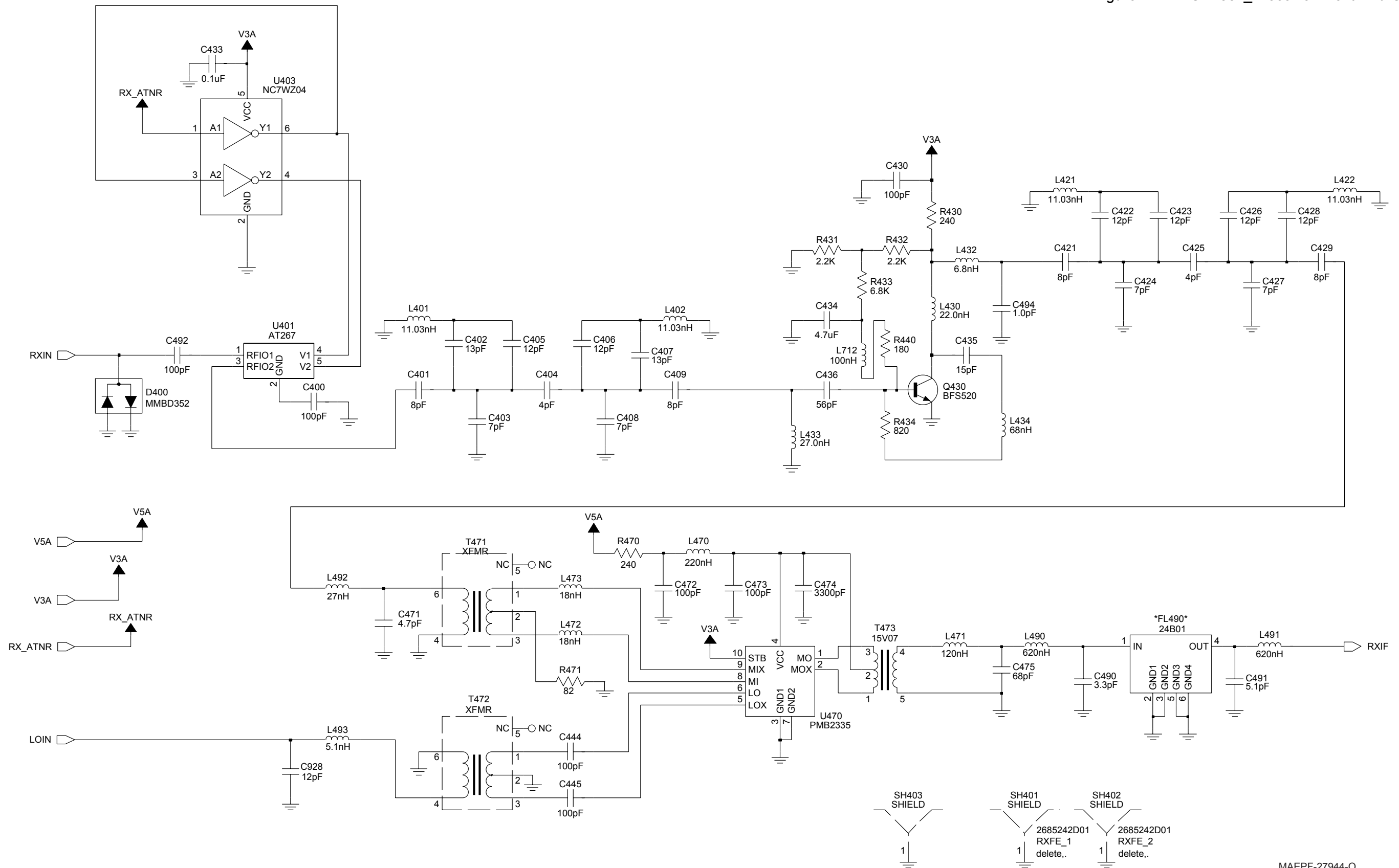
12.1 Transceiver (RF) Board

Figure 12-1. NUE7337_ Transceiver (RF) Board Overall Circuit Schematic



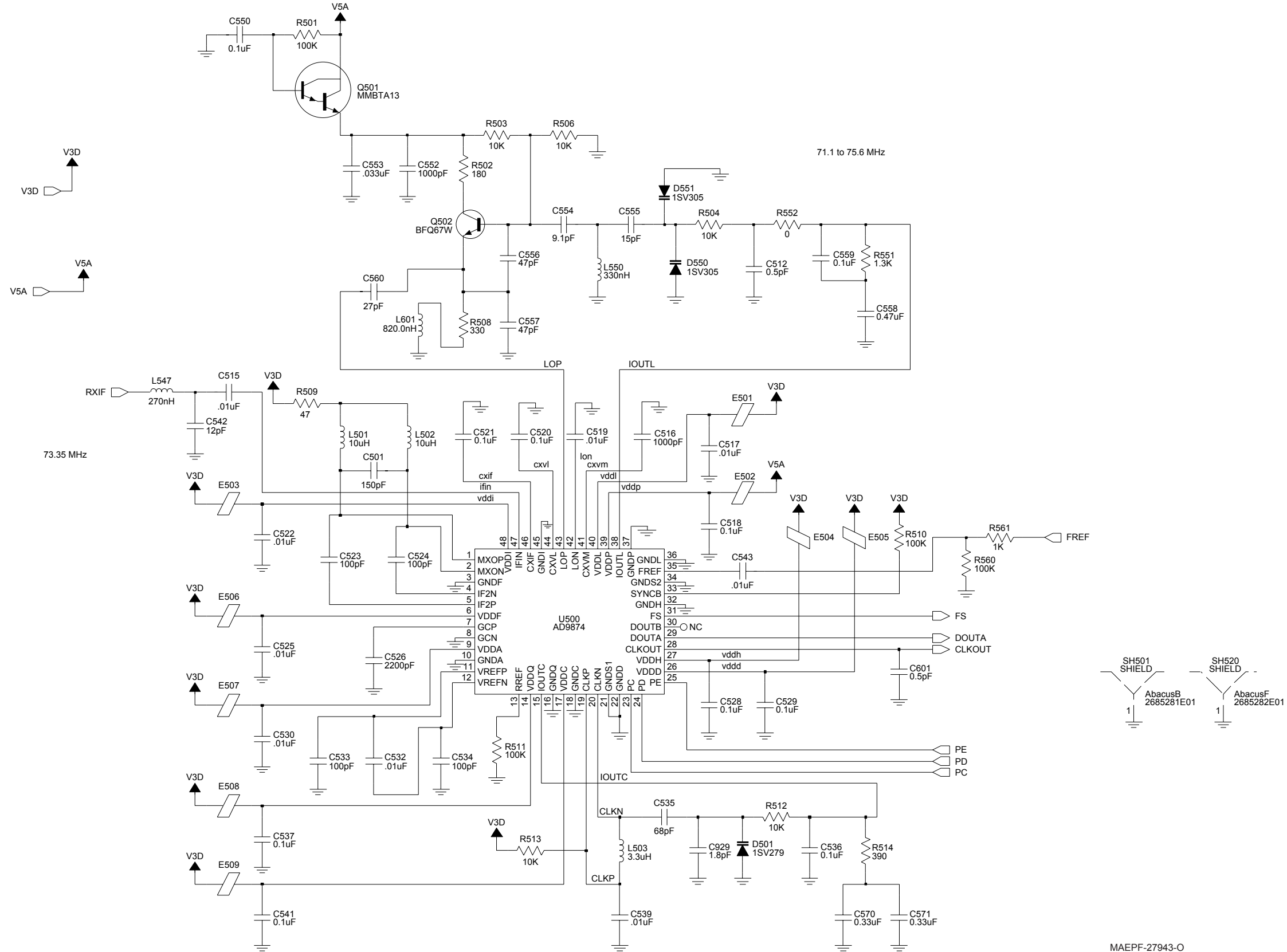
MAEPF-27946-O

Figure 12-2. NUE7337_ Receiver Front-End Circuit



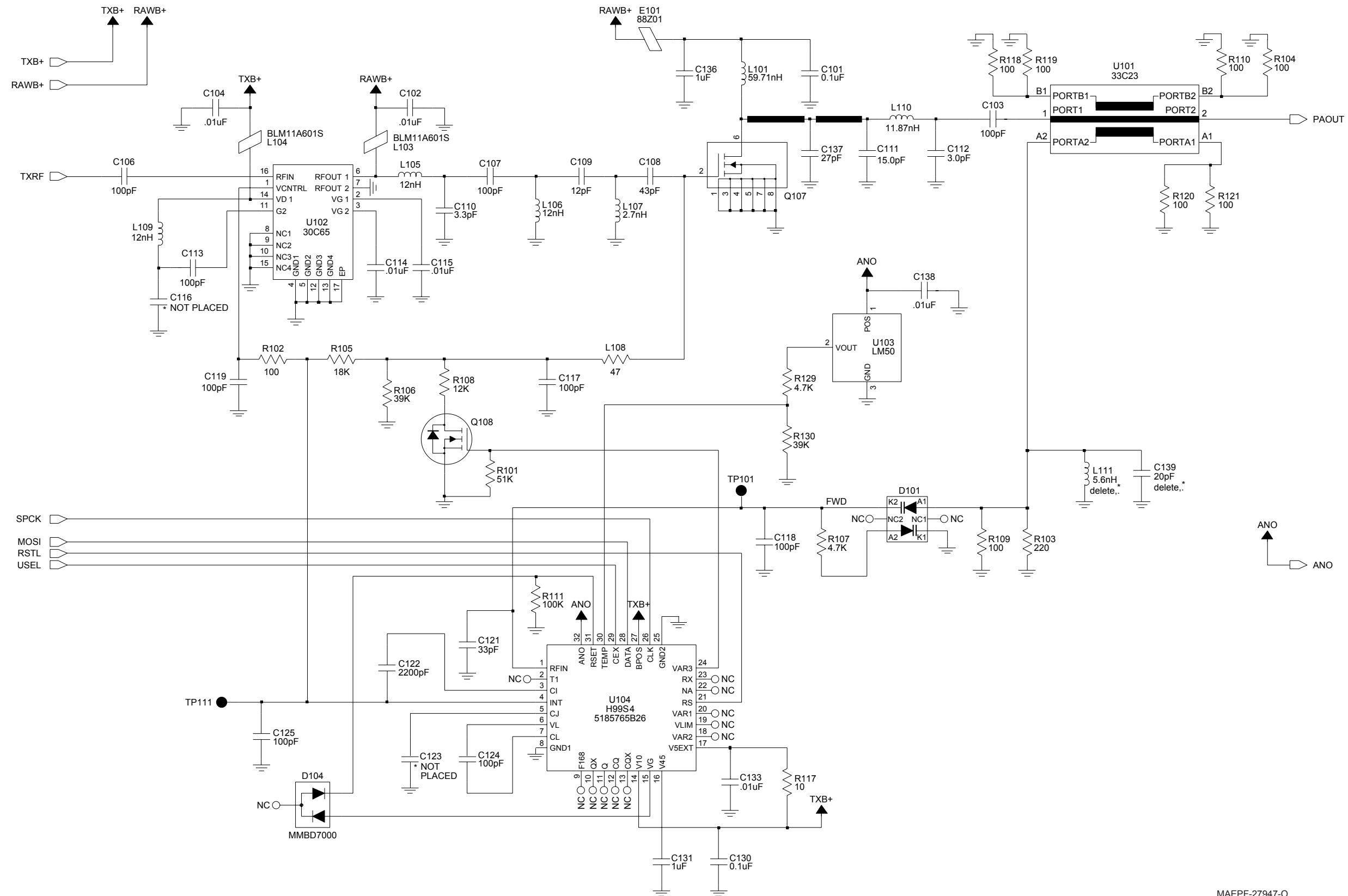
MAEPF-27944-O

Figure 12-3. NUE7337_ Receiver Back-End Circuit



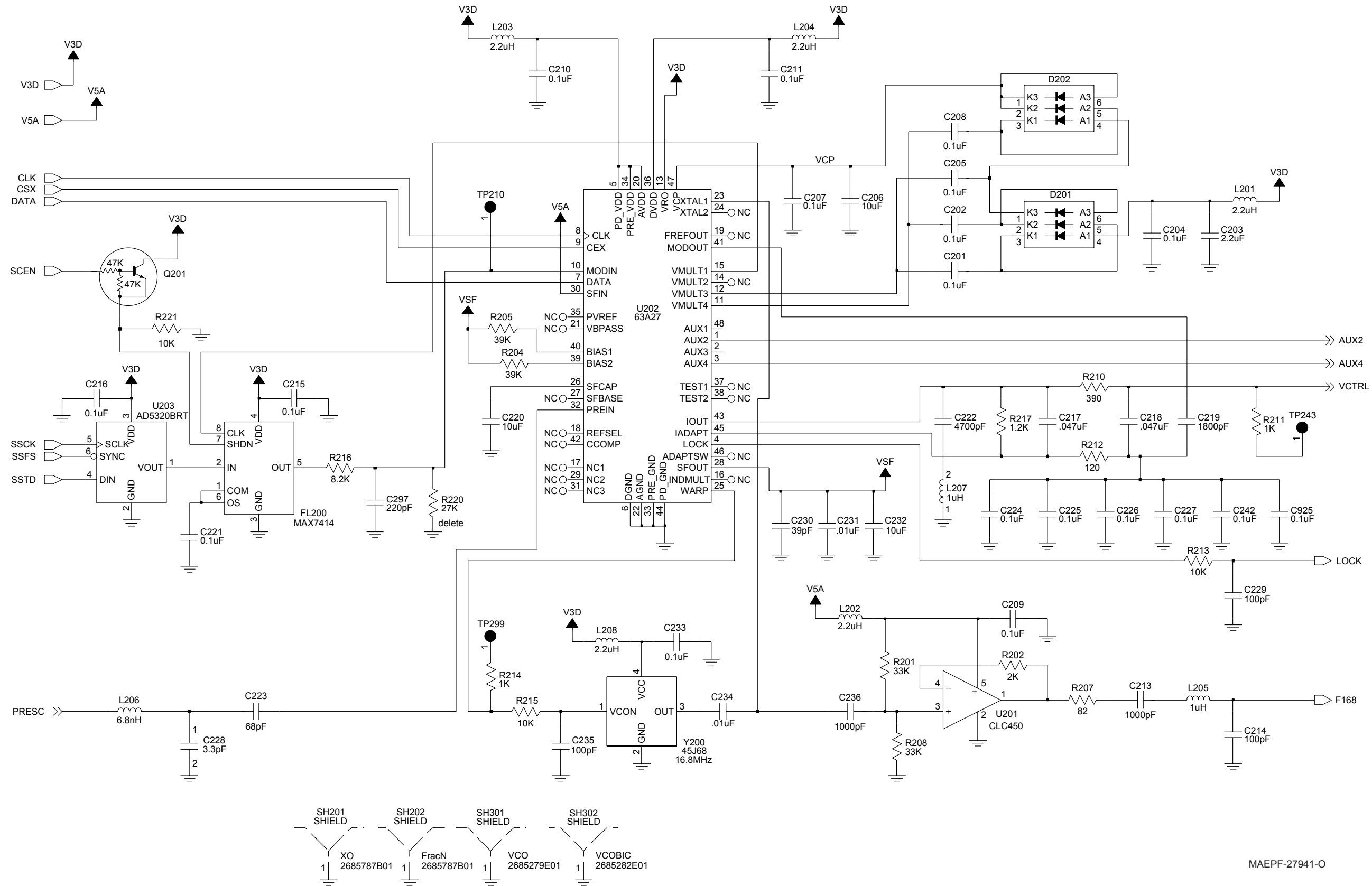
MAEPF-27943-O

Figure 12-4. NUE7337_ Transmitter and Automatic Level Control Circuits



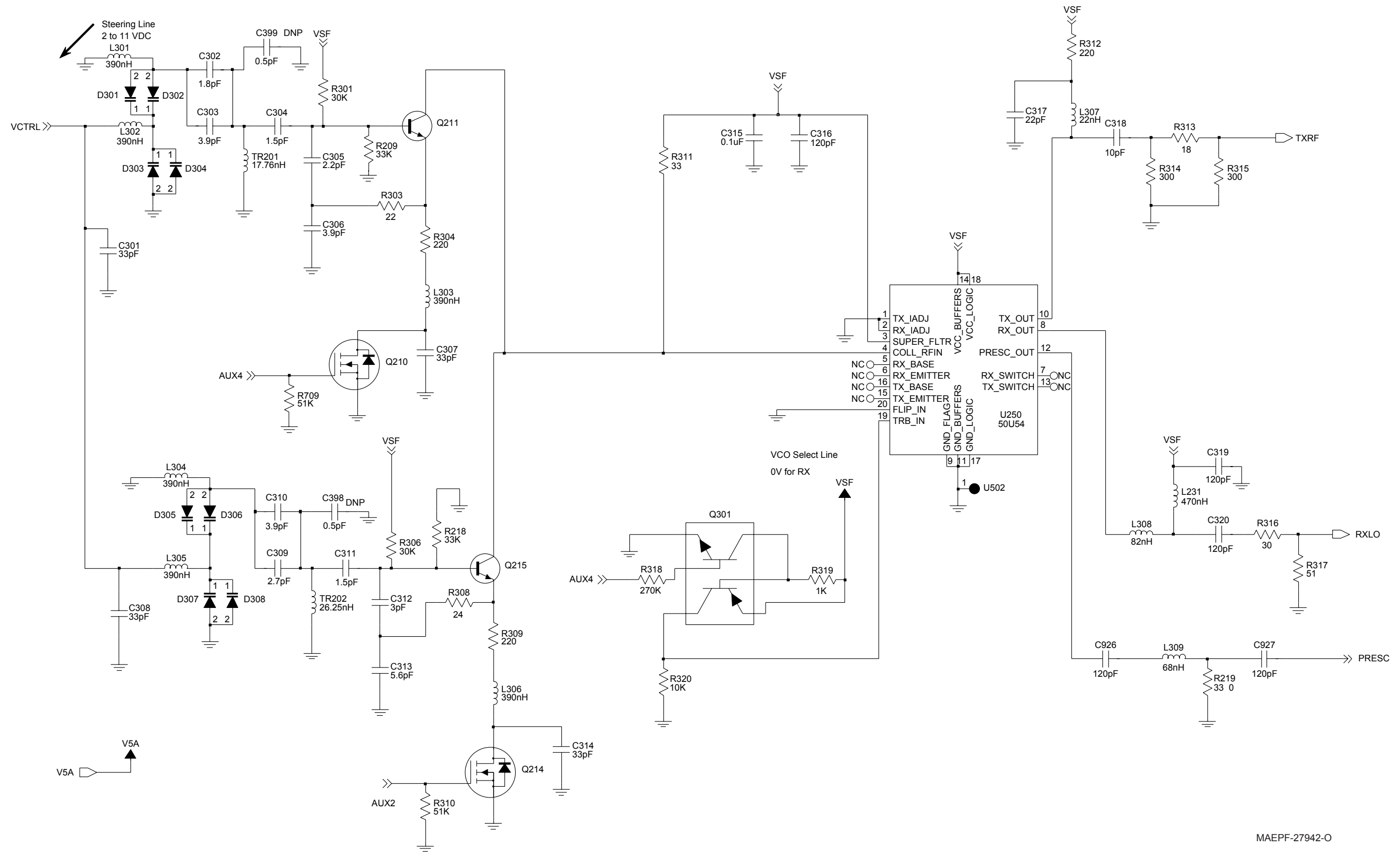
MAEPF-27947-O

Figure 12-5. NUE7337_ Frequency Generation Unit (Synthesizer) Circuit—1 of 2



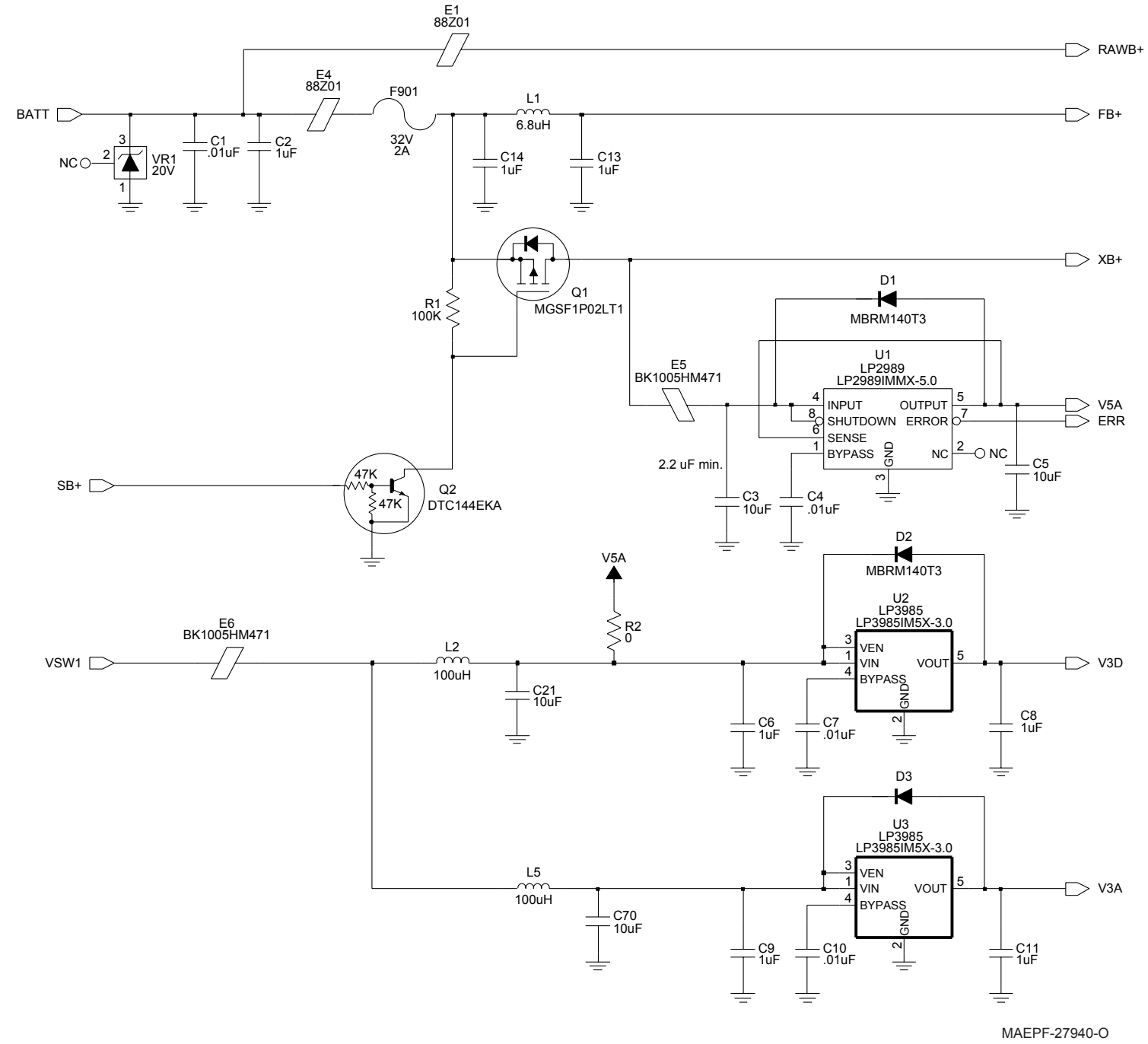
MAEPF-27941-O

Figure 12-6. NUE7337_ Frequency Generation Unit (Synthesizer) Circuit—2 of 2



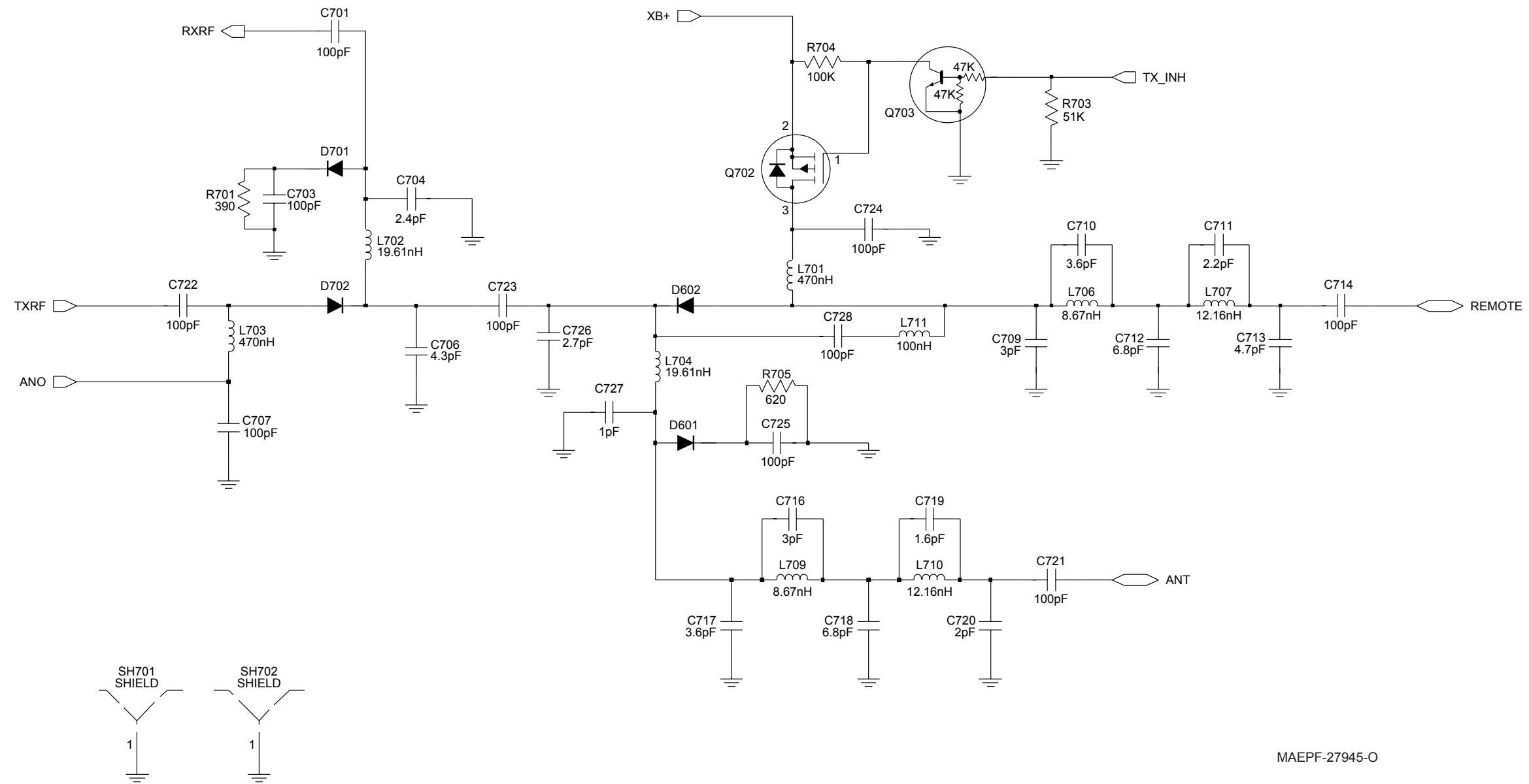
MAEPF-27942-O

Figure 12-7. NUE7337_ DC Power



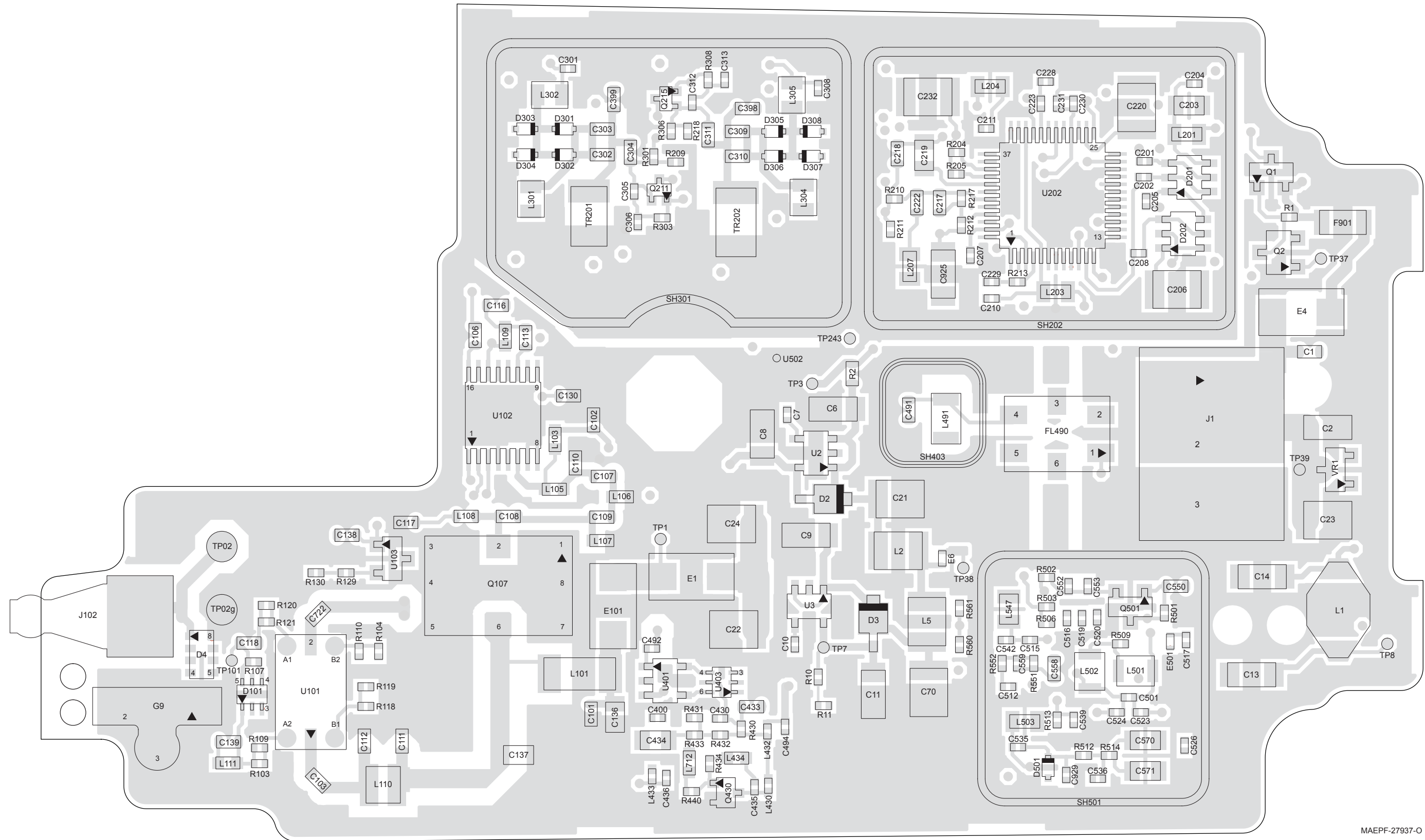
MAEPF-27940-O

Figure 12-8. NUE7337_ Antenna Switch and Harmonic Filter



MAEPF-27945-O

Figure 12-10. NUE7337_ Transceiver (RF) Board Layout—Side 2



MAEPF-27937-O

NUE7337_ Transceiver (RF) Board Parts List

Ref. Des.	Motorola Part Number	Description
C1	2113741F49	CAP CHIP CL2 X7R REEL 10000
C10	2113743L41	CAP CHIP 10000 PF 10% X7R
C101	2113743E20	CAP CHIP .10 UF 10%
C102	2113741F49	CAP CHIP CL2 X7R REEL 10000
C103	2113740F51	CAP CHIP REEL CL1 +/-30 100
C104	2113741F49	CAP CHIP CL2 X7R REEL 10000
C106	2113740F51	CAP CHIP REEL CL1 +/-30 100
C107	2113740F51	CAP CHIP REEL CL1 +/-30 100
C108	2113740F42	CAP CHIP REEL CL1 +/-30 43
C109	2113740F29	CAP CHIP REEL CL1 +/-30 12
C11	2113743S01	CAP CER CHIP 1.0 UF 10% 16V
C110	2113740F15	CAP CHIP REEL CL1 +/-30 3.3
C111	2113951A37	CAP NPO 15.0PF +/-5% 250V HI FREQ
C112	2113951A21	CAP NPO 3.00PF +/-1PF 250V HI FREQ
C113	2113740F51	CAP CHIP REEL CL1 +/-30 100
C114	2113741F49	CAP CHIP CL2 X7R REEL 10000
C115	2113741F49	CAP CHIP CL2 X7R REEL 10000
C116	NOTPLACED	64AM DUMMY PART NUMBER
C117	2113740F51	CAP CHIP REEL CL1 +/-30 100
C118	2113740F51	CAP CHIP REEL CL1 +/-30 100
C119	2113740F51	CAP CHIP REEL CL1 +/-30 100
C12	2113743L17	CAP CHIP 1000 PF 10% X7R
C121	2113743N38	CAP CHIP 33.0 PF 5% COG

Ref. Des.	Motorola Part Number	Description
C122	2113743L25	CAP CHIP 2200 PF 10% X7R
C123	NOTPLACED	64AM DUMMY PART NUMBER
C124	2113743N50	CAP CHIP 100 PF 5% COG
C125	2113740F51	CAP CHIP REEL CL1 +/-30 100
C13	2113743S01	CAP CER CHIP 1.0 UF 10% 16V
C130	2113743E20	CAP CHIP .10 UF 10%
C131	2113743A31	CAP CHIP 1.0 UF 10% X7R
C133	2113743L41	CAP CHIP 10000 PF 10% X7R
C136	2113743A31	CAP CHIP 1.0 UF 10% X7R
C137	2113742J06	CAP CHIP 27 PF 5% 0805 ACCU-P
C138	2113741F49	CAP CHIP CL2 X7R REEL 10000
C139	NOTPLACED	64AM DUMMY PART NUMBER
C14	2113743S01	CAP CER CHIP 1.0 UF 10% 16V
C15	2113743E20	CAP CHIP .10 UF 10%
C2	2113743S01	CAP CER CHIP 1.0 UF 10% 16V
C201	2113743M24	CAP CHIP 100000 PF +80-20% Y5V
C202	2113743M24	CAP CHIP 100000 PF +80-20% Y5V
C203	2113743F18	CAP CHIP 2.2 UF 16V +80-20%
C204	2113743M24	CAP CHIP 100000 PF +80-20% Y5V
C205	2113743M24	CAP CHIP 100000 PF +80-20% Y5V
C206	2113743T19	CAP 10UF 16V CER 3225 X5R
C207	2113743M24	CAP CHIP 100000 PF +80-20% Y5V
C208	2113743M24	CAP CHIP 100000 PF +80-20% Y5V
C209	2113743M24	CAP CHIP 100000 PF +80-20% Y5V
C21	2113743T19	CAP 10UF 16V CER 3225 X5R

Ref. Des.	Motorola Part Number	Description
C210	2113743M24	CAP CHIP 100000 PF +80-20% Y5V
C211	2113743M24	CAP CHIP 100000 PF +80-20% Y5V
C213	2113743L17	CAP CHIP 1000 PF 10% X7R
C214	2113743N50	CAP CHIP 100 PF 5% COG
C215	2113743M24	CAP CHIP 100000 PF +80-20% Y5V
C216	2113743M24	CAP CHIP 100000 PF +80-20% Y5V
C217	2113743E12	CAP CHIP .047 UF 10% X7R
C218	2113743E12	CAP CHIP .047 UF 10% X7R
C219	2109720D19	CAP CHIP LOW DIST 1800 SOV
C22	2113743T19	CAP 10UF 16V CER 3225 X5R
C220	2113743T19	CAP 10UF 16V CER 3225 X5R
C221	2113743M24	CAP CHIP 100000 PF +80-20% Y5V
C222	2113741F41	CAP CHIP CL2 X7R REEL 4700
C223	2113743N46	QAP CHIP 68.0 PF 5% COG
C224	2109720D14	CAP CER CHIP LOW DIST .1 UF
C225	2109720D14	CAP CER CHIP LOW DIST .1 UF
C226	2109720D14	CAP CER CHIP LOW DIST .1 UF
C227	2109720D14	CAP CER CHIP LOW DIST .1 UF
C228	2113743Q14	CAP CHIP 3.3 PF +/-1PF 20*40
C229	2113743N50	CAP CHIP 100 PF 5% COG
C23	2113743T19	CAP 10UF 16V CER 3225 X5R
C230	2113743N40	CAP CHIP 39.0 PF 5% COG
C231	2113743L41	CAP CHIP 10000 PF 10% X7R
C232	2113743T19	CAP 10UF 16V CER 3225 X5R
C233	2113743M24	CAP CHIP 100000 PF +80-20% Y5V

Ref. Des.	Motorola Part Number	Description
C234	2113743L41	CAP CHIP 10000 PF 10% X7R
C235	2113743N50	CAP CHIP 100 PF 5% COG
C236	2113743L17	CAP CHIP 1000 PF 10% X7R
C24	2113743T19	CAP 10UF 16V CER 3225 X5R
C242	2109720D14	CAP CER CHIP LOW DIST .1 UF
C297	2113743L01	CAP CHIP 220 PF 10% X7R
C3	2113743T19	CAP 10UF 16V CER 3225 X5R
C301	2113743N38	CAP CHIP 33.0 PF 5% COG
C302	2113740F09	CAP CHIP REEL CL1 +/-30 1.8
C303	2113740L08	CAP CER CHIP 3.9 PF +/-0.1PF
C304	2113740F07	CAP CHIP REEL CL1 +/-30 1.5
C305	2113743N10	CAP CHIP 2.2 PF +/-25PF COG
C306	2113743N16	CAP CHIP 3.9 PF +/-25PF COG
C307	2113743N38	CAP CHIP 33.0 PF 5% COG
C308	2113743N38	CAP CHIP 33.0 PF 5% COG
C309	2113740L04	CAP CER CHIP 2.7 PF +/-0.1PF
C310	2113740L08	CAP CER CHIP 3.9 PF +/-0.1PF
C311	2113740F07	CAP CHIP REEL CL1 +/-30 1.5
C312	2113743N13	CAP CHIP 3.0 PF +/-25PF COG
C313	2113743N20	CAP CHIP 5.6 PF +/-5PF COG
C314	2113743N38	CAP CHIP 33.0 PF 5% COG
C315	2113743M24	CAP CHIP 100000 PF +80-20% Y5V
C316	2113743N52	CAP CHIP 120 PF 5% COG
C317	2113743N34	CAP CHIP 22.0 PF 5% COG
C318	2113743N26	CAP CHIP 10.0 PF 5% COG
C319	2113743N52	CAP CHIP 120 PF 5% COG
C320	2113743N52	CAP CHIP 120 PF 5% COG

Ref. Des.	Motorola Part Number	Description
C398	NOTPLACED	64AM DUMMY PART NUMBER
C399	NOTPLACED	64AM DUMMY PART NUMBER
C4	2113743L41	CAP CHIP 10000 PF 10% X7R
C400	2113743N50	CAP CHIP 100 PF 5% COG
C401	2113743N65	CAP CHIP 8.0PF 16V .5PF COG
C402	2113743N29	CAP 13PF 20X40
C403	2113743N64	CAP CHIP 7.0PF 16V .5PF COG
C404	2113743N58	CAP CHIP 4.0PF 16V .25PF COG
C405	2113743N28	CAP CHIP 12.0 PF 5% COG
C406	2113743N28	CAP CHIP 12.0 PF 5% COG
C407	2113743N29	CAP 13PF 20X40
C408	2113743N64	CAP CHIP 7.0PF 16V .5PF COG
C409	2113743N65	CAP CHIP 8.0PF 16V .5PF COG
C421	2113743N65	CAP CHIP 8.0PF 16V .5PF COG
C422	2113743N28	CAP CHIP 12.0 PF 5% COG
C423	2113743N28	CAP CHIP 12.0 PF 5% COG
C424	2113743N64	CAP CHIP 7.0PF 16V .5PF COG
C425	2113743N58	CAP CHIP 4.0PF 16V .25PF COG
C426	2113743N28	CAP CHIP 12.0 PF 5% COG
C427	2113743N64	CAP CHIP 7.0PF 16V .5PF COG
C428	2113743N28	CAP CHIP 12.0 PF 5% COG
C429	2113743N65	CAP CHIP 8.0PF 16V .5PF COG
C430	2113743N50	CAP CHIP 100 PF 5% COG
C433	2113743E20	CAP CHIP .10 UF 10%
C434	2113928C04	CAP CER CHIP 4.7UF 6.3V10%0805
C435	2113743N30	CAP CHIP 15.0 PF 5% COG
C436	2113743N44	CAP CHIP 56.0 PF 5% COG
C444	2113743N50	CAP CHIP 100 PF 5% COG

Ref. Des.	Motorola Part Number	Description
C445	2113743N50	CAP CHIP 100 PF 5% COG
C471	2113743N18	CAP CHIP 4.7 PF +-.25PF COG
C472	2113743N50	CAP CHIP 100 PF 5% COG
C473	2113743N50	CAP CHIP 100 PF 5% COG
C474	2113743L29	CAP CHIP 3300 PF 10% X7R
C475	2113740F47	CAP CHIP REEL CL1 +/-30 68
C490	2113740F15	CAP CHIP REEL CL1 +/-30 3.3
C491	2113740F20	CAP CHIP REEL CL1 +/-30 5.1
C492	2113743N50	CAP CHIP 100 PF 5% COG
C494	2104801Z06	CAP CER NPO 1.0PF 16V 1005 SMD
C5	2113743T19	CAP 10UF 16V CER 3225 X5R
C501	2113743N54	CAP CHIP 150 PF 5% COG
C512	NOTPLACED	64AM DUMMY PART NUMBER
C515	2113743L41	CAP CHIP 10000 PF 10% X7R
C516	2113743L17	CAP CHIP 1000 PF 10% X7R
C517	2113743L41	CAP CHIP 10000 PF 10% X7R
C518	2113928N01	CAP CER CHIP 0.1UF 10% 6.3
C519	2113743L41	CAP CHIP 10000 PF 10% X7R
C520	2113928N01	CAP CER CHIP 0.1UF 10% 6.3
C521	2113928N01	CAP CER CHIP 0.1UF 10% 6.3
C522	2113743L41	CAP CHIP 10000 PF 10% X7R
C523	2113743N50	CAP CHIP 100 PF 5% COG
C524	2113743N50	CAP CHIP 100 PF 5% COG
C525	2113743L41	CAP CHIP 10000 PF 10% X7R
C526	2113743L25	CAP CHIP 2200 PF 10% X7R
C528	2113928N01	CAP CER CHIP 0.1UF 10% 6.3

Ref. Des.	Motorola Part Number	Description
C529	2113928N01	CAP CER CHIP 0.1UF 10% 6.3
C530	2113743L41	CAP CHIP 10000 PF 10% X7R
C532	2113743L41	CAP CHIP 10000 PF 10% X7R
C533	2113743N50	CAP CHIP 100 PF 5% COG
C534	2113743N50	CAP CHIP 100 PF 5% COG
C535	2113743N46	QAP CHIP 68.0 PF 5% COG
C536	2113928N01	CAP CER CHIP 0.1UF 10% 6.3
C537	2113928N01	CAP CER CHIP 0.1UF 10% 6.3
C539	2113743L41	CAP CHIP 10000 PF 10% X7R
C541	2113928N01	CAP CER CHIP 0.1UF 10% 6.3
C542	2113743N28	CAP CHIP 12.0 PF 5% COG
C543	2113743L41	CAP CHIP 10000 PF 10% X7R
C550	2113743E20	CAP CHIP .10 UF 10%
C552	2113743L17	CAP CHIP 1000 PF 10% X7R
C553	2113743L50	CAP CHIP 33000 PF 10%
C554	2113743N25	CAP CHIP 9.1 PF +-.5PF COG
C555	2113743N30	CAP CHIP 15.0 PF 5% COG
C556	2113743N42	CAP CHIP 47.0 PF 5% COG
C557	2113743N42	CAP CHIP 47.0 PF 5% COG
C558	2113946D01	CAP CER CHP 0.47UF 6.3V 10%
C559	2113928N01	CAP CER CHIP 0.1UF 10% 6.3
C560	2113743N36	CAP CHIP 27.0 PF 5% COG
C570	2113743A24	CAP CHIP .330 UF 10% 16V
C571	2113743A24	CAP CHIP .330 UF 10% 16V
C6	2113743S01	CAP CER CHIP 1.0 UF 10% 16V
C601	NOTPLACED	64AM DUMMY PART NUMBER
C7	2113743L41	CAP CHIP 10000 PF 10% X7R
C70	2113743T19	CAP 10UF 16V CER 3225 X5R

Ref. Des.	Motorola Part Number	Description
C701	2113740F51	CAP CHIP REEL CL1 +/-30 100
C703	2113740F51	CAP CHIP REEL CL1 +/-30 100
C704	2113740F12	CAP CHIP REEL CL1 +/-30 2.4
C706	2113740F18	CAP CHIP REEL CL1 +/-30 4.3
C707	2113740F51	CAP CHIP REEL CL1 +/-30 100
C709	2113740F14	CAP CHIP REEL CL1 +/-30 3.0
C710	2113740F16	CAP CHIP REEL CL1 +/-30 3.6
C711	2113740F11	CAP CHIP REEL CL1 +/-30 2.2
C712	2113740F23	CAP CHIP REEL CL1 +/-30 6.8
C713	2113740F19	CAP CHIP REEL CL1 +/-30 4.7
C714	2113740F51	CAP CHIP REEL CL1 +/-30 100
C716	2113740F14	CAP CHIP REEL CL1 +/-30 3.0
C717	2113740F16	CAP CHIP REEL CL1 +/-30 3.6
C718	2113740F23	CAP CHIP REEL CL1 +/-30 6.8
C719	2113740F08	CAP CHIP REEL CL1 +/-30 1.6
C720	2113740F10	CAP CHIP REEL CL1 +/-30 2.0
C721	2113740F51	CAP CHIP REEL CL1 +/-30 100
C722	2113740F51	CAP CHIP REEL CL1 +/-30 100
C723	2113740F51	CAP CHIP REEL CL1 +/-30 100
C724	2113740F51	CAP CHIP REEL CL1 +/-30 100
C725	2113740F51	CAP CHIP REEL CL1 +/-30 100
C726	2113740F13	CAP CHIP REEL CL1 +/-30 2.7

Ref. Des.	Motorola Part Number	Description
C727	2113740F03	CAP CHIP REEL CL1 +/-30 1.0
C728	2113740F51	CAP CHIP REEL CL1 +/-30 100
C8	2113743S01	CAP CER CHIP 1.0 UF 10% 16V
C9	2113743S01	CAP CER CHIP 1.0 UF 10% 16V
C925	2109720D14	CAP CER CHIP LOW DIST .1 UF
C926	2113743N52	CAP CHIP 120 PF 5% COG
C927	2113743N52	CAP CHIP 120 PF 5% COG
C928	2113740F29	CAP CHIP REEL CL1 +/-30 12
C929	2113944A07	CAP CER CHP 1.8PF 50V +/-0.25PF
D1	4813833A20	DIODE SCHOTTKY 1A 40V PWRMITE
D101	4802197J83	DUAL SHOTTKY DIODE MBD330DWT1
D104	4805129M06	DIODE MMBD7000
D2	4813833A20	DIODE SCHOTTKY 1A 40V PWRMITE
D201	4802233J09	DIODE TRIPLE SOT25-RH
D202	4802233J09	DIODE TRIPLE SOT25-RH
D3	4813833A20	DIODE SCHOTTKY 1A 40V PWRMITE
D301	4809877C08	DIODE VARACTOR 1SV279 SMD
D302	4809877C08	DIODE VARACTOR 1SV279 SMD
D303	4809877C08	DIODE VARACTOR 1SV279 SMD
D304	4809877C08	DIODE VARACTOR 1SV279 SMD
D305	4809877C08	DIODE VARACTOR 1SV279 SMD
D306	4809877C08	DIODE VARACTOR 1SV279 SMD
D307	4809877C08	DIODE VARACTOR 1SV279 SMD
D308	4809877C08	DIODE VARACTOR 1SV279 SMD

Ref. Des.	Motorola Part Number	Description
D4	4805656W39	QUAD ESD SUPPRESSOR ARRAY -41206ESD
D400	4813825A19	DIODE SCHOTTKY BARRIER SERIES
D501	4809877C08	DIODE VARACTOR 1SV279 SMD
D550	4809877C13	DIODE VARACTOR ISV305 SMD
D551	NOTPLACED	64AM DUMMY PART NUMBER
D601	4805656W24	"DIODE, PIN RF"
D602	4805656W24	"DIODE, PIN RF"
D701	4805656W24	"DIODE, PIN RF"
D702	4805656W24	"DIODE, PIN RF"
E1	2405688Z01	INDUCTOR FERRITE BEAD
E101	2405688Z01	INDUCTOR FERRITE BEAD
E4	2405688Z01	INDUCTOR FERRITE BEAD
E5	2480640Z01	SURFACE MOUNT FERRITE BEAD
E501	2480640Z01	SURFACE MOUNT FERRITE BEAD
E502	2480640Z01	SURFACE MOUNT FERRITE BEAD
E503	2480640Z01	SURFACE MOUNT FERRITE BEAD
E504	2480640Z01	SURFACE MOUNT FERRITE BEAD
E505	2480640Z01	SURFACE MOUNT FERRITE BEAD
E506	2480640Z01	SURFACE MOUNT FERRITE BEAD
E507	2480640Z01	SURFACE MOUNT FERRITE BEAD
E508	2480640Z01	SURFACE MOUNT FERRITE BEAD
E509	2480640Z01	SURFACE MOUNT FERRITE BEAD
E6	2480640Z01	SURFACE MOUNT FERRITE BEAD
F901	6505757V02	FUSE SURFACE MT 2AMP
FL200	9185130D01	FLTR SW CAP 3 POLE BUTTERW
FL490	9185924B01	"FILTER, 73.35 MHZ 3-POLE CRYSTAL"

Ref. Des.	Motorola Part Number	Description
G9	3985931D02	CLIP GND
J1	0986237A02	CONNECTOR (CONTACT BATTERY)
J101	3985585E01	CONTACT ANTENNA
J102	3985586E01	CONTACT RF CONNECTOR
L1	2486085A04	"COIL, 6.8 UH POWER INDUCTOR"
L101	2460591K40	COIL AIR WOUND INDUC 59.71
L103	2480574F01	IND FERRITE CHIP 600 OHM 0603
L104	2480574F01	IND FERRITE CHIP 600 OHM 0603
L105	2413926H13	IND CHIP 12.0 NH 5%
L106	2413926H13	IND CHIP 12.0 NH 5%
L107	2413926H05	IND CHIP 2.7 NH +/-0.3NH
L108	0660076N17	RES CHIP 47 OHM 5 1/16
L109	2413926H13	IND CHIP 12.0 NH 5%
L110	2460591C03	COIL AIR WOUND INDUC 11.87
L111	NOTPLACED	64AM DUMMY PART NUMBER
L2	2462587L50	FERRITE INDUCTOR 100UH
L201	2462587Q20	"IND CHIP 2,200 NH 20%"
L202	2462587Q20	"IND CHIP 2,200 NH 20%"
L203	2462587Q20	"IND CHIP 2,200 NH 20%"
L204	2462587Q20	"IND CHIP 2,200 NH 20%"
L205	2462587Q47	"IND CHIP 1,000 NH 10%"
L206	2462587V21	CHIP IND 6.8 NH 5% 0805
L207	2462587Q47	"IND CHIP 1,000 NH 10%"
L208	2462587Q20	"IND CHIP 2,200 NH 20%"
L231	2462587N61	CHIP IND 470 NH 5%
L301	2462587V59	IND CHIP 390 NH 5%
L302	2462587V59	IND CHIP 390 NH 5%
L303	2462587V59	IND CHIP 390 NH 5%
L304	2462587V59	IND CHIP 390 NH 5%
L305	2462587V59	IND CHIP 390 NH 5%
L306	2462587V59	IND CHIP 390 NH 5%
L307	2462587T38	IND CHIP 22NH 5% LOW PRO

Ref. Des.	Motorola Part Number	Description
L308	2409377M16	"IDCTR,CHIP,82NH,5%,400 MA,,58OHM,SM,"
L309	2409377M14	"IDCTR,CHIP,68NH,5%,600 MA,,34OHM,SM,"
L401	2460591B04	COIL AIR WOUND INDUC 11.03
L402	2460591B04	COIL AIR WOUND INDUC 11.03
L421	2460591B04	COIL AIR WOUND INDUC 11.03
L422	2460591B04	COIL AIR WOUND INDUC 11.03
L430	2409154M92	"FIXED INDUCTOR,CHIP,22NH,5%,2 00MA,,"
L432	2409154M11	"FIXED INDUCTOR,CHIP,6.8NH,5%,, .33OH"
L433	2409154M18	"FIXED INDUCTOR,CHIP,27NH,5%,, 1.04OH"
L434	2409377M14	"IDCTR,CHIP,68NH,5%,600 MA,,34OHM,SM,"
L470	2409377M36	"IDCTR,CHIP,220NH,5%,200 MA,2.1OHM,SM"
L471	2409377M19	"IDCTR,CHIP,120NH,5%,300 MA,,65OHM,SM"
L472	2409377M07	"IDCTR,CHIP,18NH,5%,700 MA,,17OHM,SM,"
L473	2409377M07	"IDCTR,CHIP,18NH,5%,700 MA,,17OHM,SM,"
L490	2462587T25	IND CHIP 620NH 5% LOW PRO
L491	2462587T25	IND CHIP 620NH 5% LOW PRO
L492	2409377M09	"IDCTR,CHIP,27NH,5%,600 MA,,22OHM,SM,"
L493	2409377M24	IND CHIP WW 5.1 NH 5% 1608
L5	2462587L50	FERRITE INDUCTOR 100UH
L501	2405769X05	COIL INDUCTOR
L502	2405769X05	COIL INDUCTOR
L503	2462587Q53	IND CHIP 3.300 NH 10%
L547	2404574Z14	IND CHIP WW 270NH 2% 2012 SMD

Ref. Des.	Motorola Part Number	Description
L550	2462587N59	CHIP IND 330 NH 5%
L601	2462587V73	IND CHIP 820.0 NH 5%
L701	2413926K31	IND CER CHIP 470.0 NH 5%
L702	2460591B80	COIL AIR WOUND INDUC 19.61
L703	2413926K31	IND CER CHIP 470.0 NH 5%
L704	2460591B80	COIL AIR WOUND INDUC 19.61
L706	2460591B22	COIL AIR WOUND INDUC 8.67
L707	2460591B59	COIL AIR WOUND INDUC 12.16
L709	2460591B22	COIL AIR WOUND INDUC 8.67
L710	2460591B59	COIL AIR WOUND INDUC 12.16
L711	2409377M17	"IDCTR,CHIP,100NH,5%,400 MA.,58OHM,SM"
L712	2409377M17	"IDCTR,CHIP,100NH,5%,400 MA.,58OHM,SM"
P900	NOTPLACED	64AM DUMMY PART NUMBER
PCB	8485271E01	PCB RF 450-488 MHZ 1-6-1 HDI LAYERS
Q1	4813821A47	TSTR P-CH HDTMOS 20V
Q107	5185633C51	MODULE RING TRANSISTOR PWR FET
Q108	4805218N11	XISTOR SOT RH BST82
Q2	4880048M01	TSTR NPN DIG 47K/47K
Q201	4880048M01	TSTR NPN DIG 47K/47K
Q210	4805218N11	XISTOR SOT RH BST82
Q211	4805793Y01	TRANS MINI SOT NPN LOW NOISE
Q214	4805218N11	XISTOR SOT RH BST82
Q215	4805793Y01	TRANS MINI SOT NPN LOW NOISE
Q301	4805921T11	XSTR DUAL PNP
Q430	4805585Q19	TRANSISTOR
Q501	4805128M19	TSTR SOT23 MMBTA13 RH
Q502	4805218N63	RF TRANS SOT 323 BFO67W
Q702	4813821A47	TSTR P-CH HDTMOS 20V

Ref. Des.	Motorola Part Number	Description
Q703	4880048M01	TSTR NPN DIG 47K/47K
R1	0662057N23	RES. CHIP 100K 5% 20X40
R10	0662057N06	RES. CHIP 20K 5% 20X40
R101	0662057N16	RES. CHIP 51K 5% 20X40
R102	0662057M50	RES. CHIP 100 5% 20X40
R103	0662057M58	RES. CHIP 220 5% 20X40
R104	0662057M50	RES. CHIP 100 5% 20X40
R105	0662057N05	RES. CHIP 18K 5% 20X40
R106	0662057N13	RES. CHIP 39K 5% 20X40
R107	0662057M90	RES. CHIP 4700 5% 20X40
R108	0662057N01	RES CHIP 12K 5% 20X40
R109	0662057M50	RES. CHIP 100 5% 20X40
R11	0662057N17	RES. CHIP 56K 5% 20X40
R110	0662057M50	RES. CHIP 100 5% 20X40
R111	0662057N23	RES. CHIP 100K 5% 20X40
R117	0662057M26	RES. CHIP 10 5% 20X40
R118	0662057M50	RES. CHIP 100 5% 20X40
R119	0662057M50	RES. CHIP 100 5% 20X40
R120	0662057M50	RES. CHIP 100 5% 20X40
R121	0662057M50	RES. CHIP 100 5% 20X40
R129	0662057M90	RES. CHIP 4700 5% 20X40
R130	0662057N13	RES. CHIP 39K 5% 20X40
R2	NOTPLACED	64AM DUMMY PART NUMBER
R201	0662057N11	RES. CHIP 33K 5% 20X40
R202	0662057M81	RES. CHIP 2000 5% 20X40
R204	0662057N13	RES. CHIP 39K 5% 20X40
R205	0662057N13	RES. CHIP 39K 5% 20X40
R207	0662057M48	RES. CHIP 82 5% 20X40
R208	0662057N11	RES. CHIP 33K 5% 20X40
R209	0662057N11	RES. CHIP 33K 5% 20X40
R210	0662057M64	RES. CHIP 390 5% 20X40
R211	0662057M74	RES. CHIP 1000 5% 20X40
R212	0662057M52	RES. CHIP 120 5% 20X40
R213	0662057M98	RES. CHIP 10K 5% 20X40
R214	0662057M74	RES. CHIP 1000 5% 20X40
R215	0662057M98	RES. CHIP 10K 5% 20X40
R216	0662057M96	RES. CHIP 8200 5% 20X40

Ref. Des.	Motorola Part Number	Description
R217	0662057M76	RES. CHIP 1200 5% 20X40
R218	0662057N11	RES. CHIP 33K 5% 20X40
R219	0662057M62	RES. CHIP 330 5% 20X40
R220	NOTPLACED	64AM DUMMY PART NUMBER
R221	0662057M98	RES. CHIP 10K 5% 20X40
R301	0662057N10	RES. CHIP 30K 5% 20X40
R303	0662057M34	RES. CHIP 22 5% 20X40
R304	0662057M58	RES. CHIP 220 5% 20X40
R306	0662057N10	RES. CHIP 30K 5% 20X40
R308	0662057M35	RES CHIP 24 5% 20X40
R309	0662057M58	RES. CHIP 220 5% 20X40
R310	0662057N16	RES. CHIP 51K 5% 20X40
R311	0662057M38	RES. CHIP 33 5% 20X40
R312	0662057M58	RES. CHIP 220 5% 20X40
R313	0662057M32	RES. CHIP 18 5% 20X40
R314	0662057M61	RES. CHIP 300 5% 20X40
R315	0662057M61	RES. CHIP 300 5% 20X40
R316	0662057M37	20X40 30 OMH 5% CHIP RESISTOR
R317	0662057M43	RES. CHIP 51 5% 20X40
R318	0662057N33	RES CHIP 270K 5% 20X40
R319	0662057M74	RES. CHIP 1000 5% 20X40
R320	0662057M98	RES. CHIP 10K 5% 20X40
R4	0662057N23	RES. CHIP 100K 5% 20X40
R430	0662057M59	RES CHIP 240 5% 20X40
R431	0662057M82	RES. CHIP 2200 5% 20X40
R432	0662057M82	RES. CHIP 2200 5% 20X40
R433	0662057M94	RES. CHIP 6800 5% 20X40
R434	0662057M72	RES. CHIP 820 5% 20X40
R440	0662057M56	RES. CHIP 180 5% 20X40
R470	0662057M59	RES CHIP 240 5% 20X40
R471	0662057M48	RES. CHIP 82 5% 20X40
R501	0662057N23	RES. CHIP 100K 5% 20X40
R502	0662057M56	RES. CHIP 180 5% 20X40
R503	0662057M98	RES. CHIP 10K 5% 20X40
R504	0662057M98	RES. CHIP 10K 5% 20X40
R506	0662057M98	RES. CHIP 10K 5% 20X40
R508	0662057M62	RES. CHIP 330 5% 20X40

Ref. Des.	Motorola Part Number	Description
R509	0662057M42	RES. CHIP 47 5% 20X40
R510	0662057N23	RES. CHIP 100K 5% 20X40
R511	0662057N23	RES. CHIP 100K 5% 20X40
R512	0662057M98	RES. CHIP 10K 5% 20X40
R513	0662057M98	RES. CHIP 10K 5% 20X40
R514	0662057M64	RES. CHIP 390 5% 20X40
R551	0662057M77	RES. CHIP 1300 5% 20X40
R552	0662057M01	RES. CHIP 0 5% 20X40
R560	0662057N23	RES. CHIP 100K 5% 20X40
R561	0662057M74	RES. CHIP 1000 5% 20X40
R6	0662057M98	RES. CHIP 10K 5% 20X40
R7	0662057M98	RES. CHIP 10K 5% 20X40
R701	0662057A39	CHIP RES 390 OHMS 5%
R703	0662057A90	CHIP RES 51K OHMS 5%
R704	0662057A97	CHIP RES 100K OHMS 5%
R705	0662057A44	CHIP RES 620 OHMS 5%
R709	0662057N16	RES. CHIP 51K 5% 20X40
R8	0662057M50	RES. CHIP 100 5% 20X40
SH201	2685787B01	SHLD FRAC-N
SH202	2685787B01	SHLD FRAC-N
SH301	2685279E01	SHIELD VCO
SH302	2685282E01	SHIELD ABACUS FRONT
SH401	2685242D01	SHLD FILTER
SH402	2685242D01	SHLD FILTER
SH403	2680624Z01	SHIELD MIXER DIODE
SH501	2685281E01	SHIELD ABACUS BACK
SH520	2685282E01	SHIELD ABACUS FRONT
SH701	2685308E01	SHEILD
SH702	2685308E01	SHEILD
T471	2580541Z02	BALUN TRANSFORMER (NEW)
T472	2580541Z02	BALUN TRANSFORMER (NEW)
T473	2505515V07	XFMR JEDI MIXER 25:1
TR201	2460591D30	COIL AIR WOUND INDUC 17.76
TR202	2460591E66	COIL AIR WOUND INDUC 26.25
U1	5185353D13	IC MINI SO-8 HI PRECISION REG 5V

Ref. Des.	Motorola Part Number	Description
U101	5185633C23	MODULE DIRECT COUPLER
U102	5185130C65	IC VHF/UHF/800 MHZ LD MOS DRIVER
U103	5185963A15	IC TEMPERATURE SENSOR 1M50C
U104	5185765B26	IC PWR CTRL IN MOS20
U2	5185353D14	IC SOT23-5 HI PRECISION REG 3V
U201	5185956E66	"IC,OP AMP,1PER PKG,LMH6723,IC"
U202	5185963A27	IC TESTED AT25016 48 PIN GFP
U203	5185368C83	IC 12 BIT DAC
U250	5105750U54	IC PKG DIE VCO BUFFER
U3	5185353D14	IC SOT23-5 HI PRECISION REG 3V
U4	5105462G78	IC EEPROM 16K SPEI CMOS
U401	5185130C83	IC 15DB DIGITAL ATTENUATOR SOT25 PKG
U403	5185143E12	IC INVERTER DUAL SC70
U470	5185130C91	IC MIXER RF SOIC 10
U500	5185963A85	IC-ABACUS III-LP
U502	NOTPLACED	64AM DUMMY PART NUMBER
VR1	4813830A33	DIODE 20V 5% 225MW MMBZ5250B_
VR2	4805656W45	DIODE TRANSIENT VOLTAGE SUPPRESSOR
Y200	4802245J68	"OSC, REF 16.8 MHZ 1.5 PPM"

12.2 VOCON Board

Figure 12-11. NCN6186_ VOCON Board Overall Circuit Schematic—Sheet 1 of 2

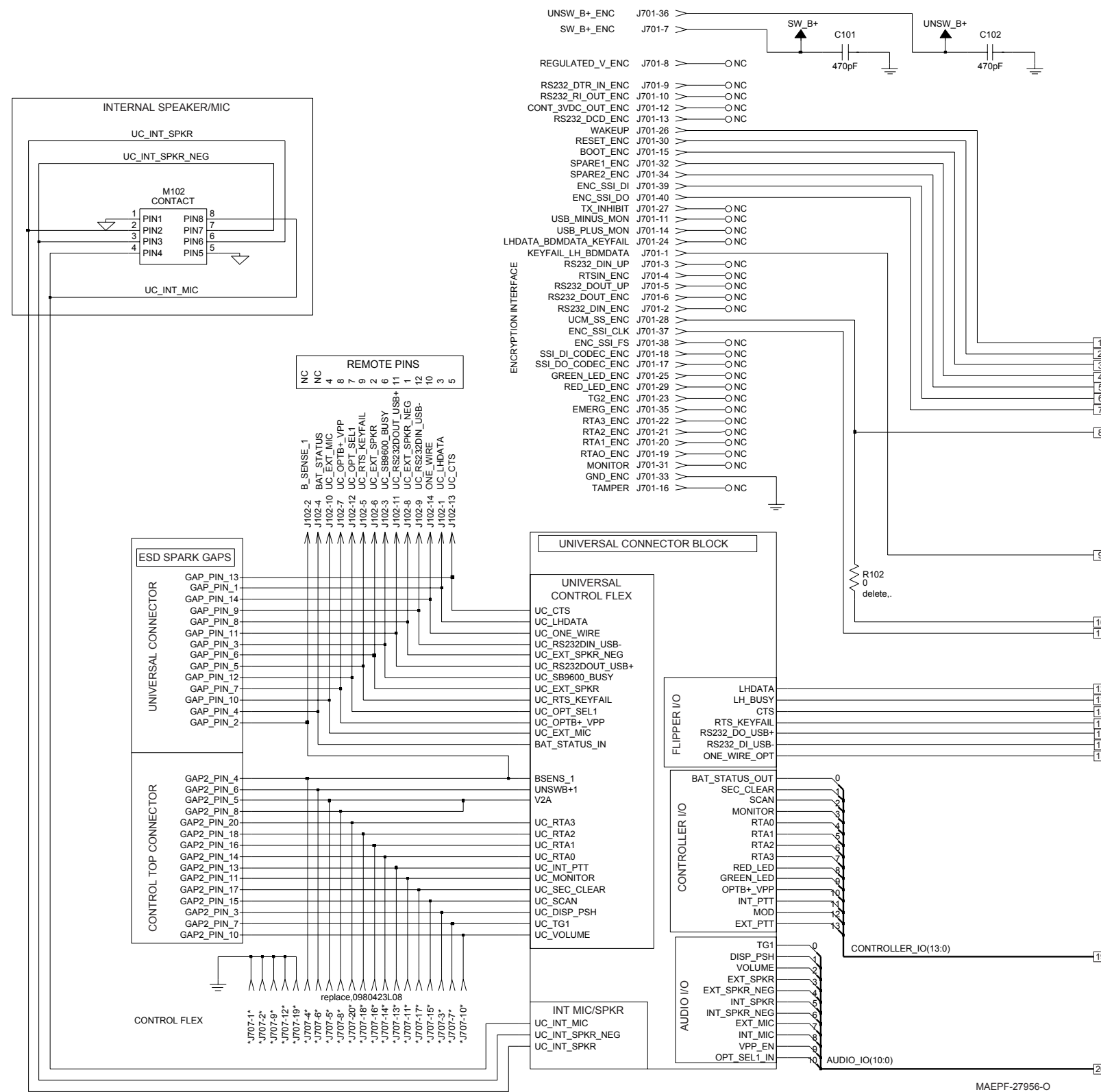


Figure 12-12. NCN6186_ VOCON Board Overall Circuit Schematic—Sheet 2 of 2

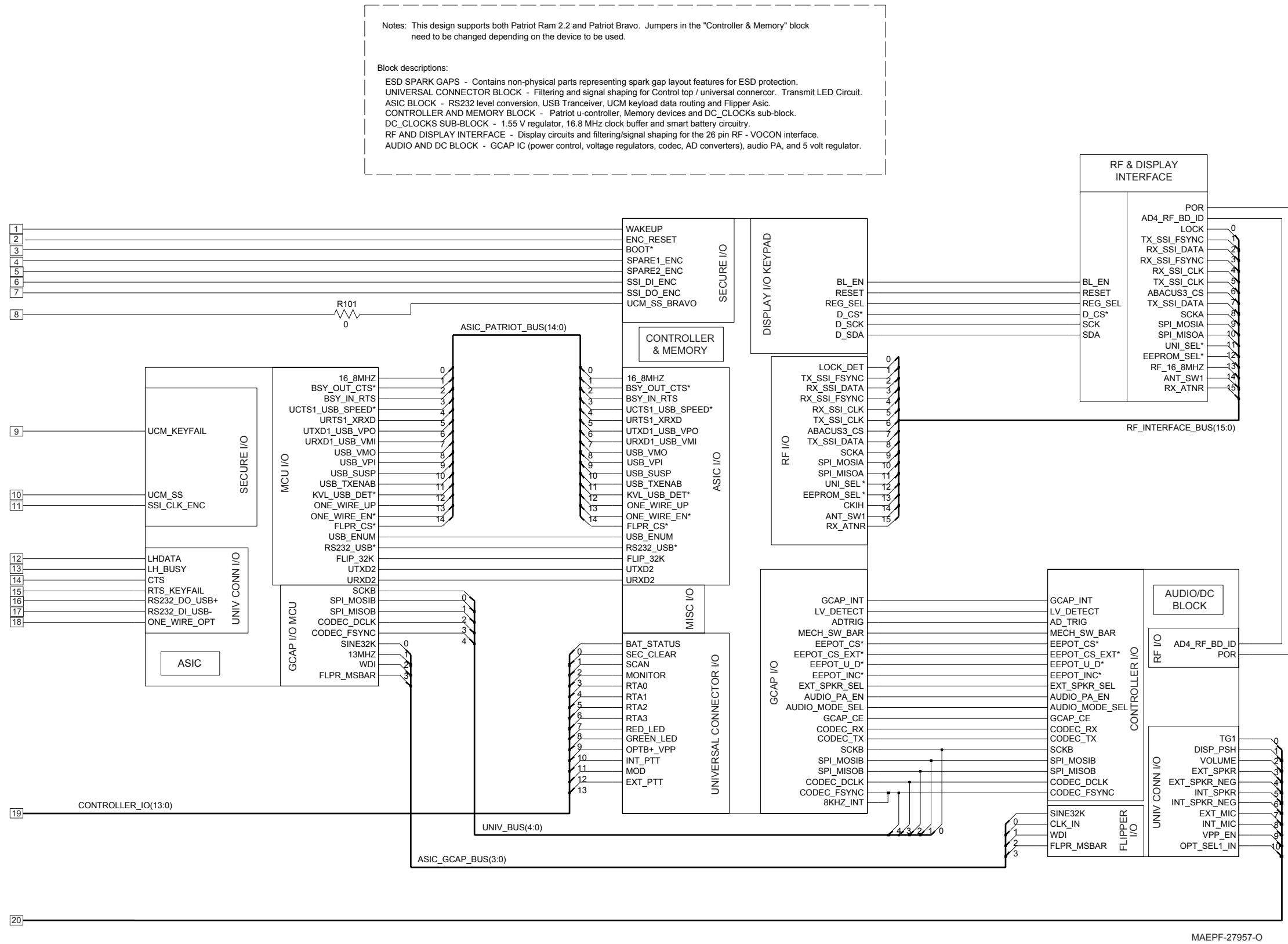


Figure 12-13. NCN6186_ VOCON Universal Connector Circuit

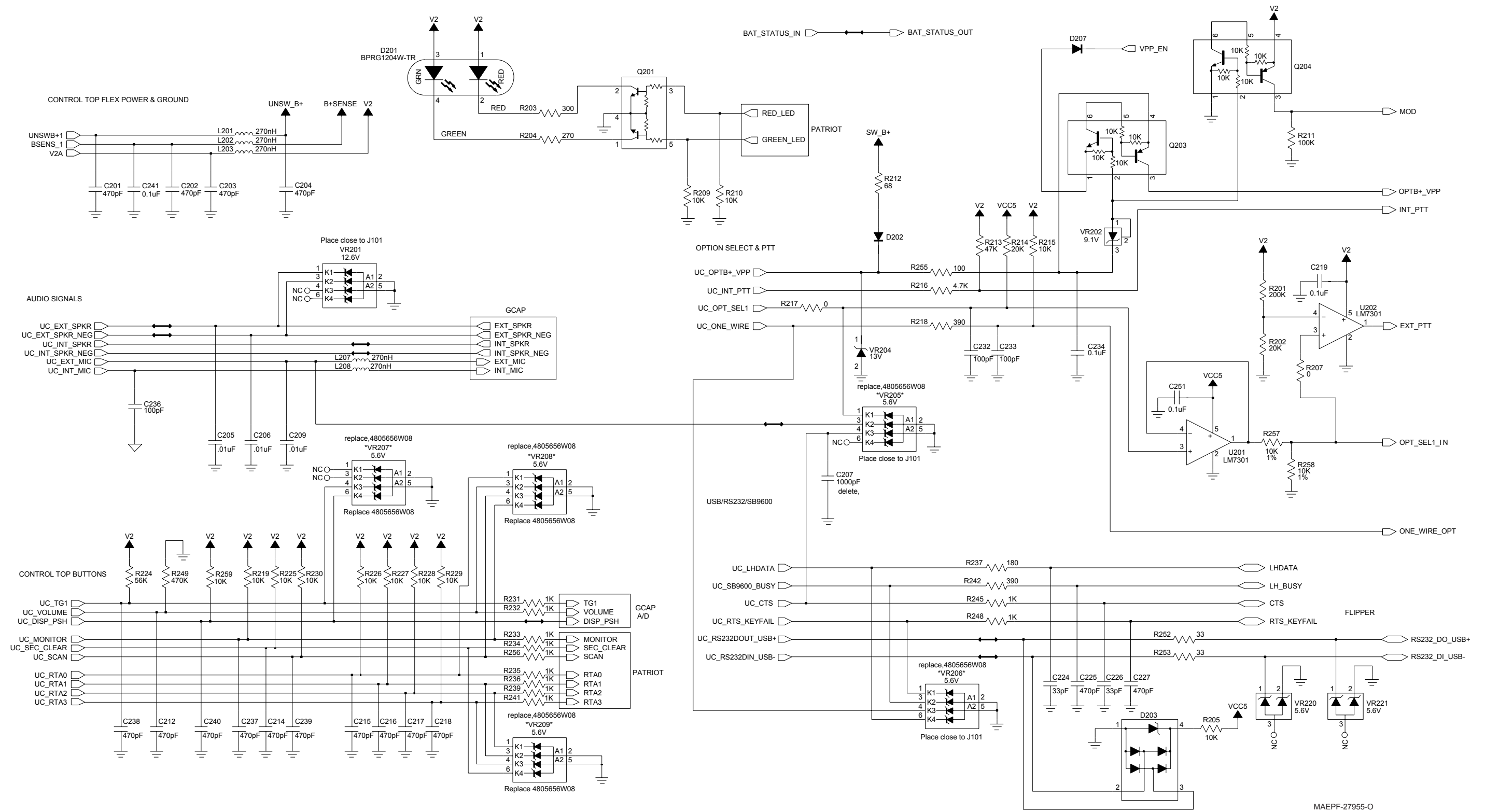


Figure 12-14. NCN6186_ VOCON Flipper Circuit

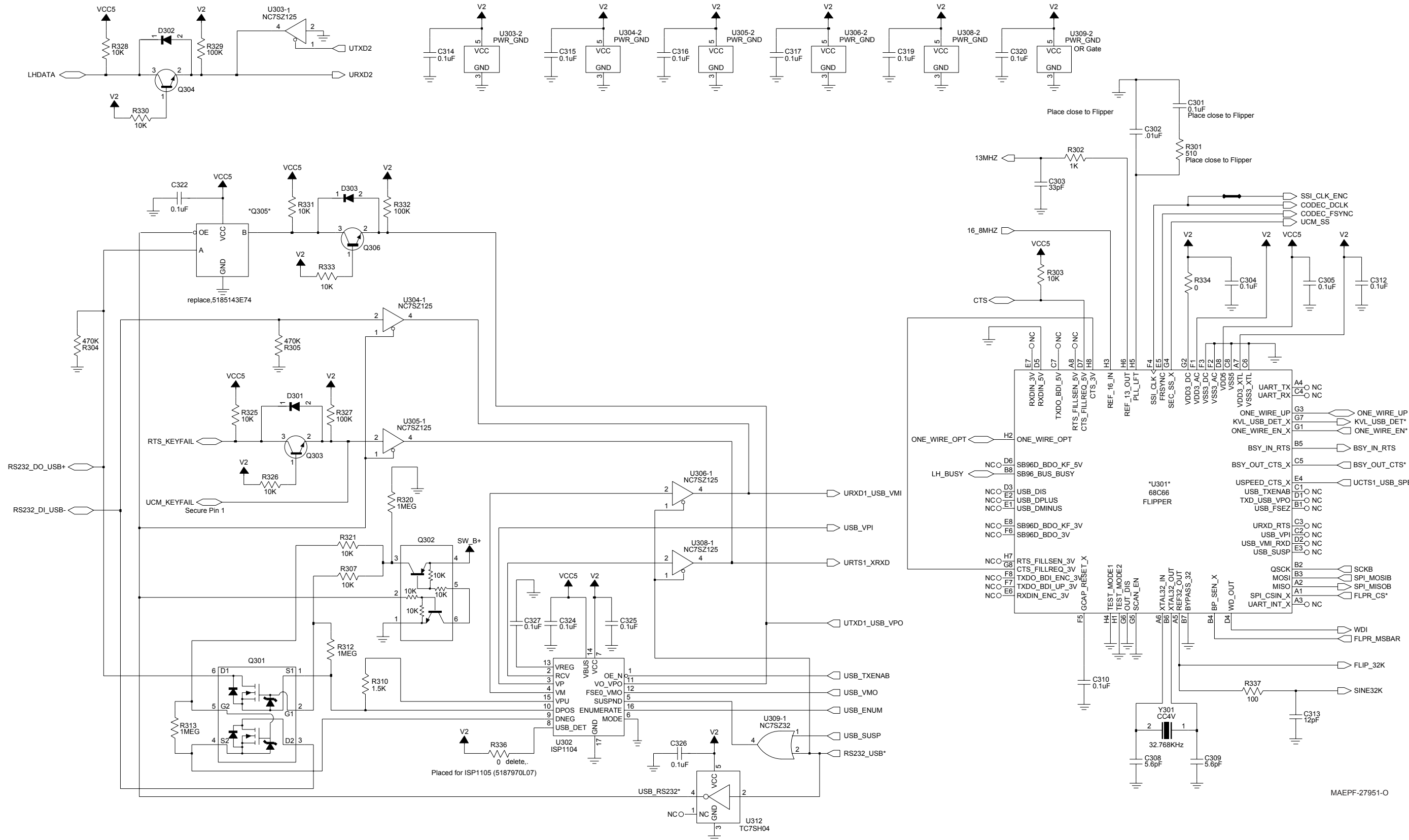
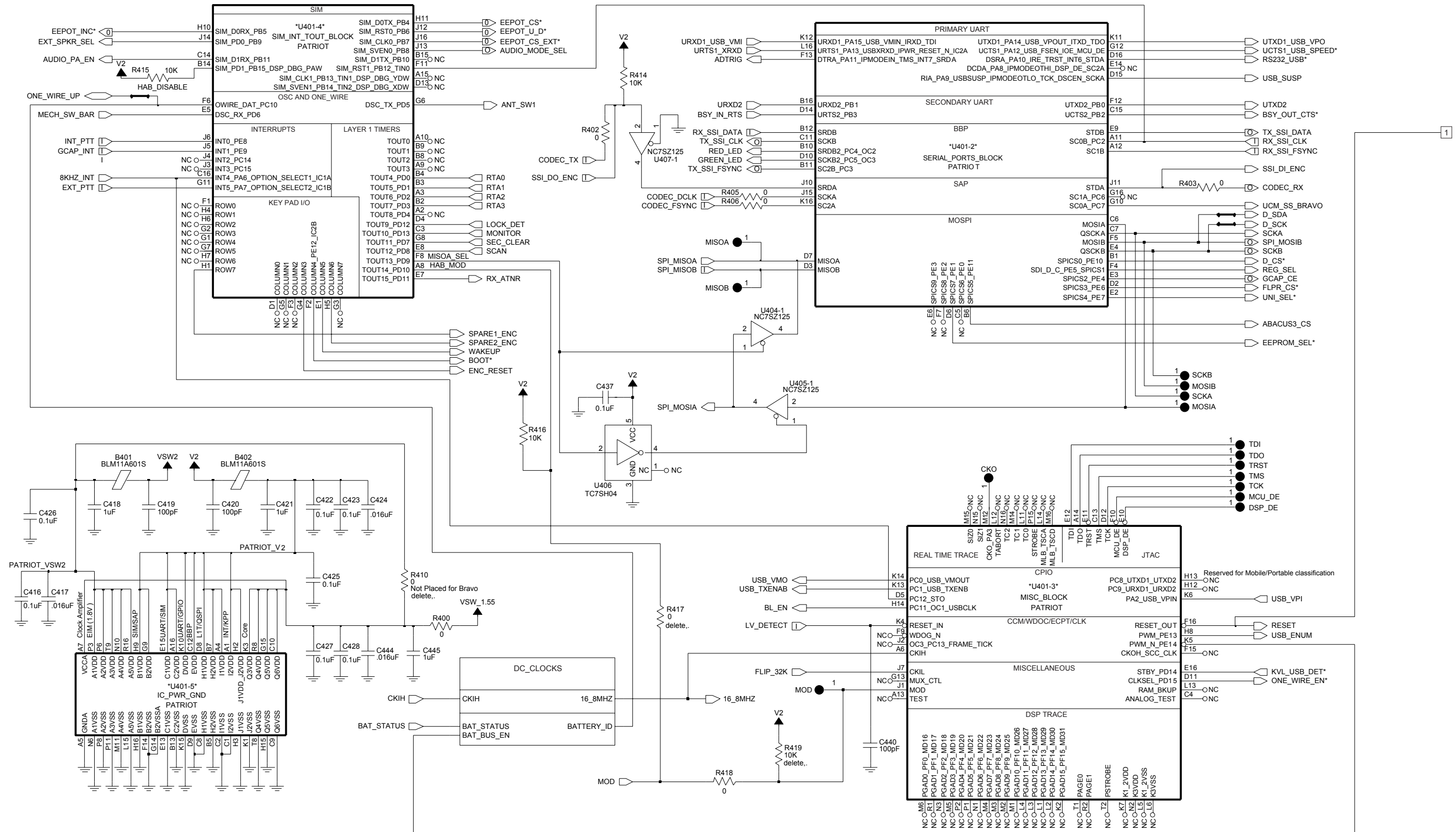


Figure 12-15. NCN6186_VOCON Controller and Memory Circuits—Sheet 1 of 2



MAEPF-27952-0

Figure 12-16. NCN6186_VOCON Controller and Memory Circuits—Sheet 2 of 2

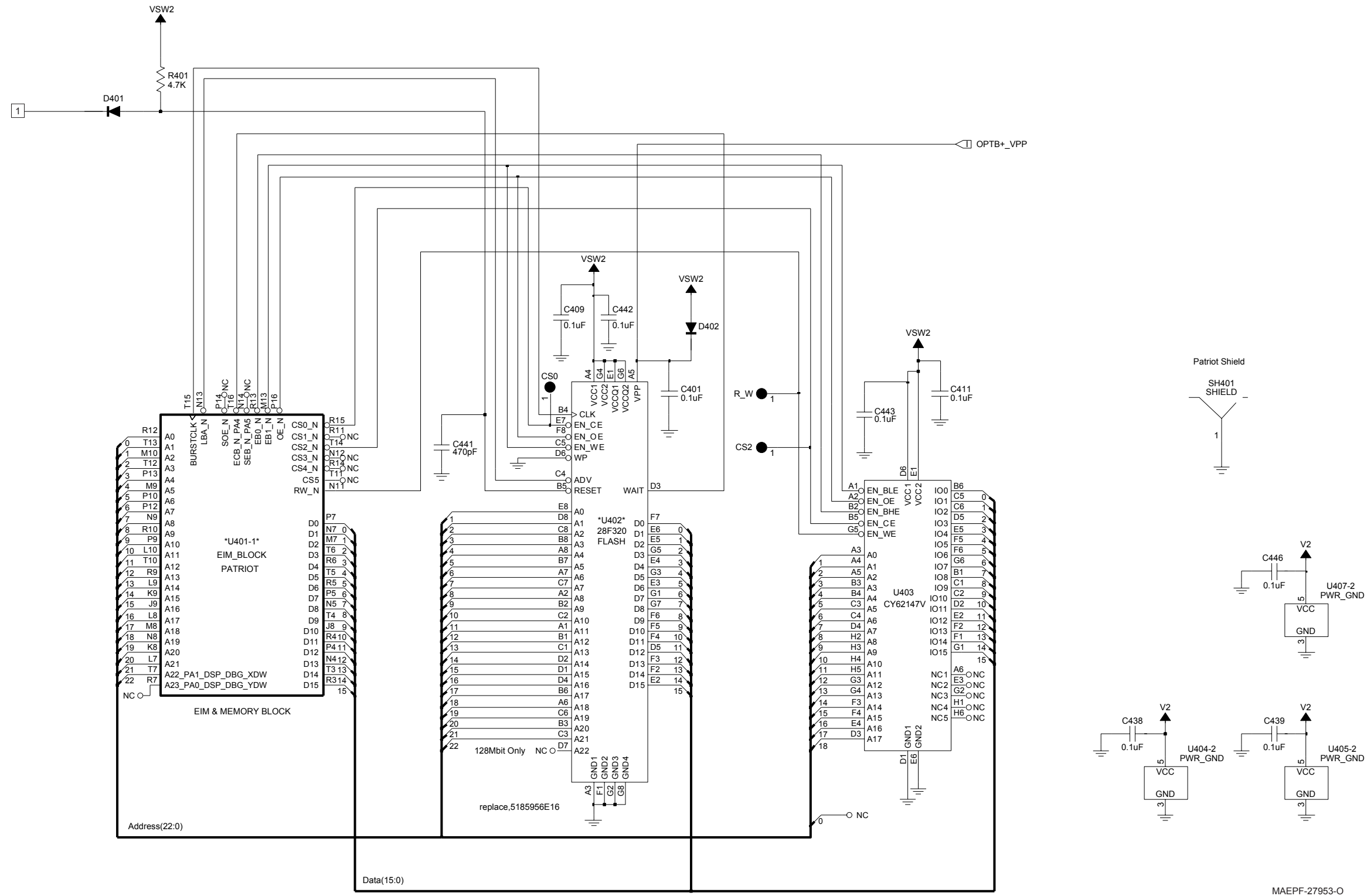
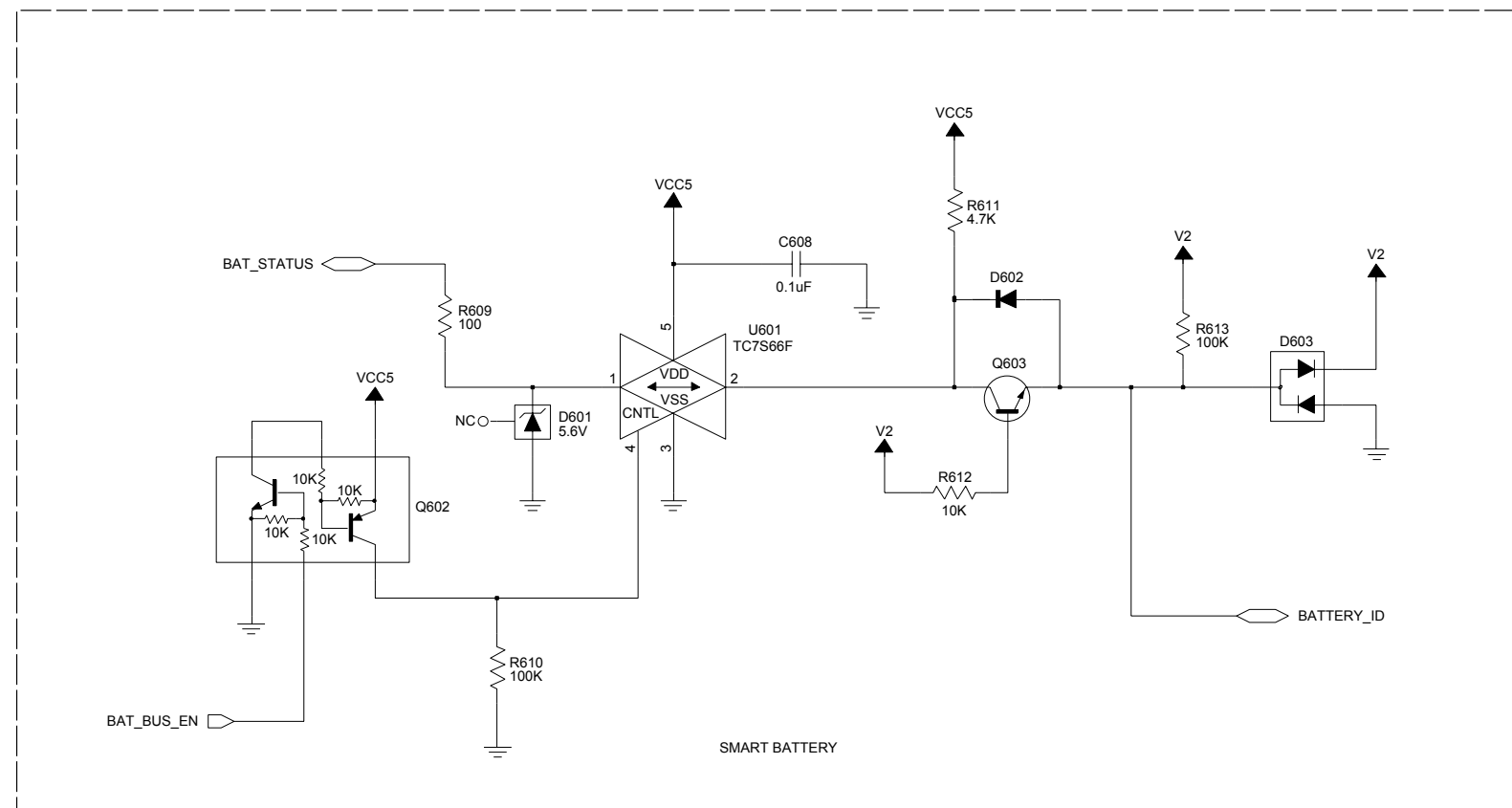
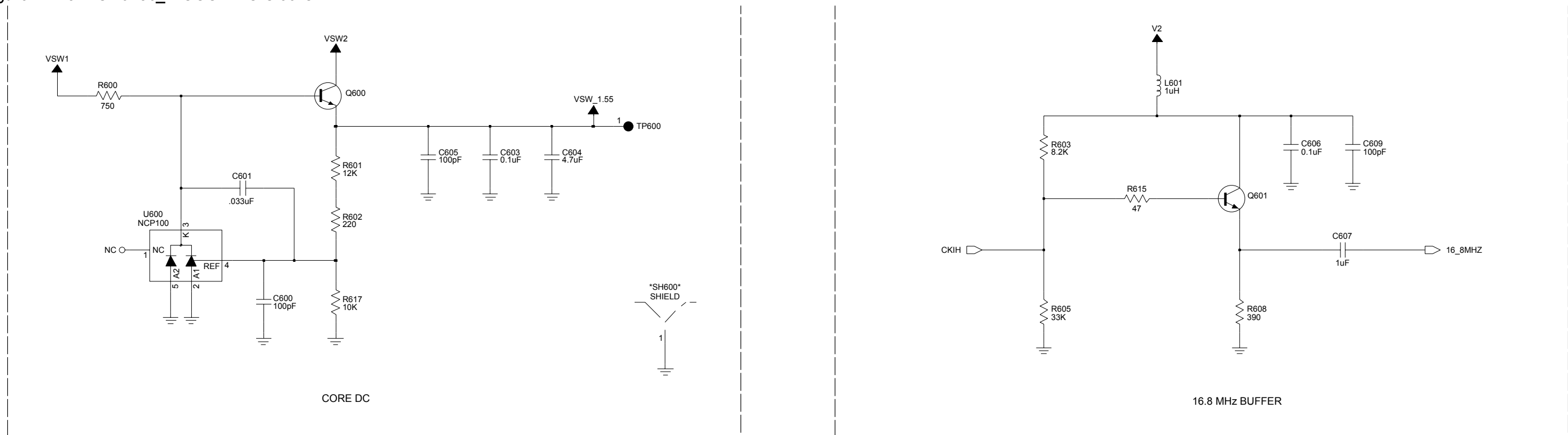


Figure 12-18. NCN6186_ VOCON DC Clocks



MAEPF-27949-O

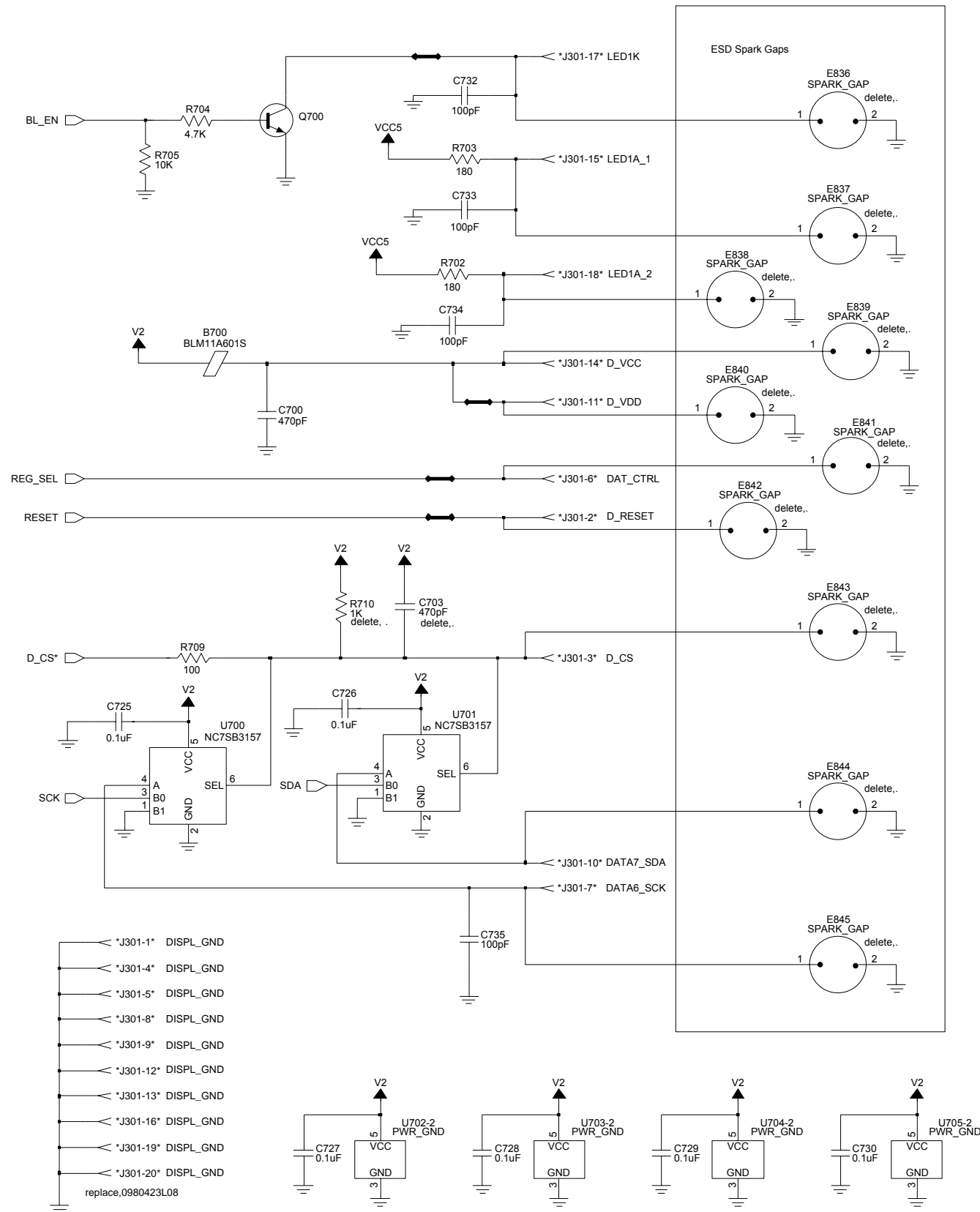
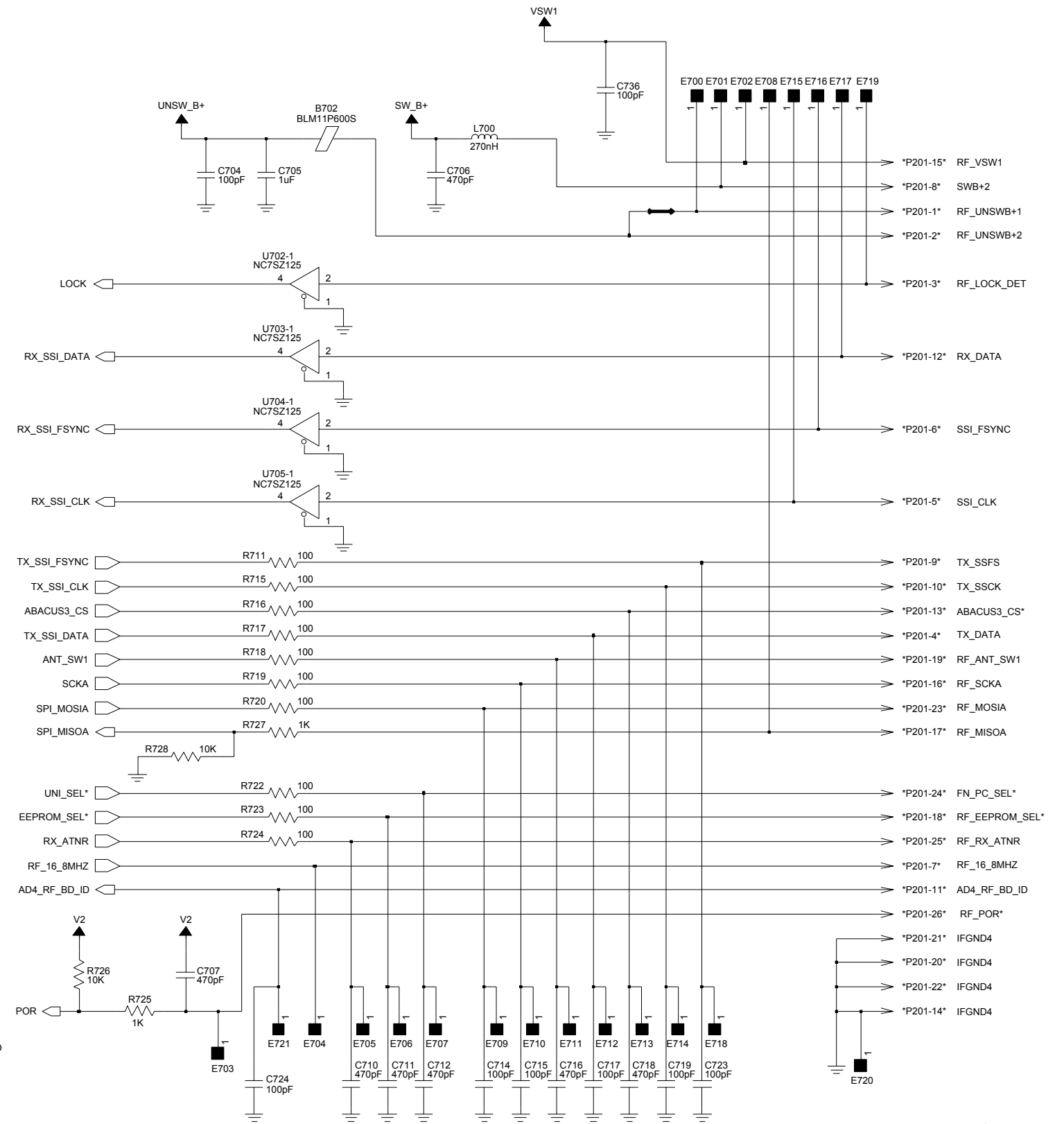


Figure 12-19. NCN6186_VOCON Display-RF Interface

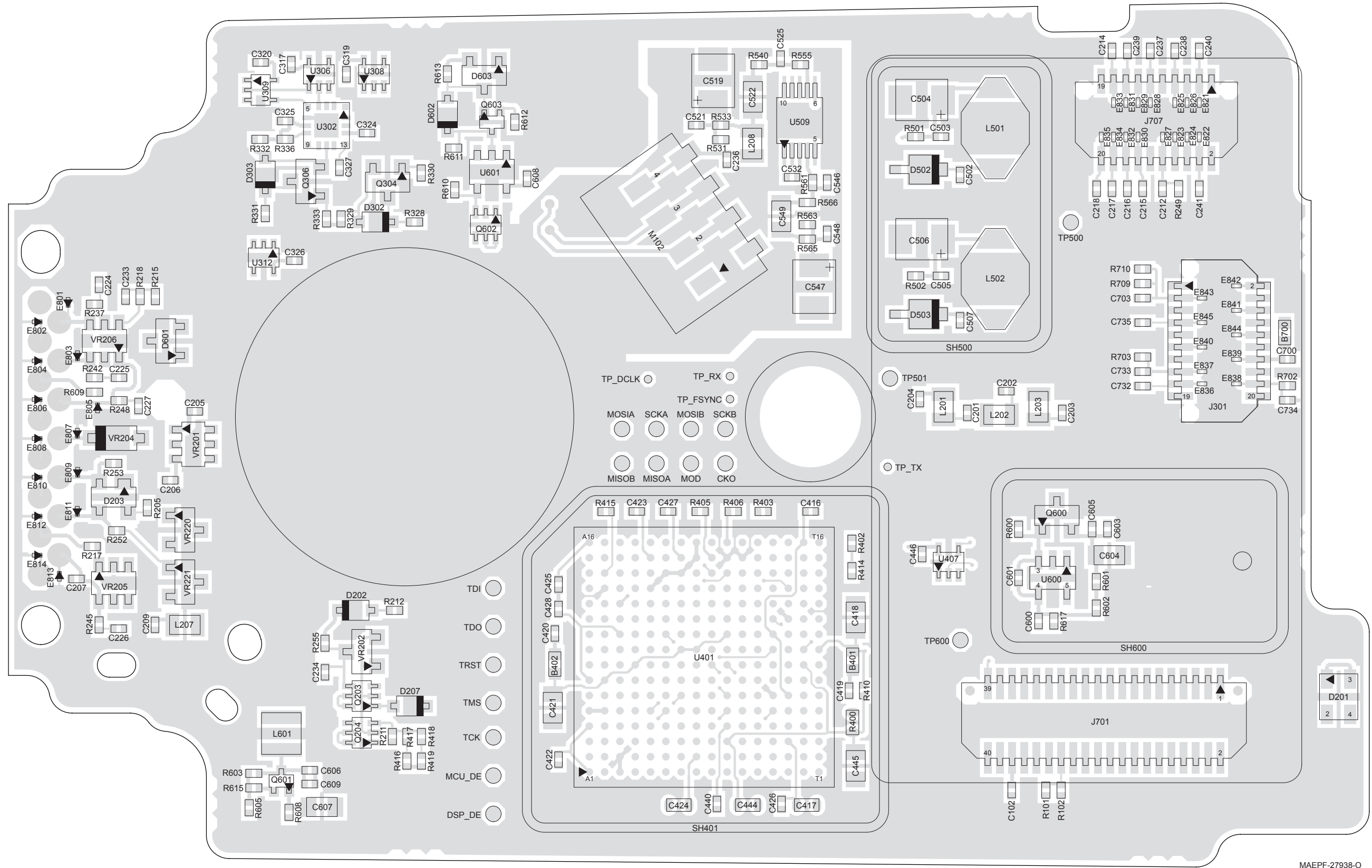


MAEPF-27950-0

Figure 12-20. NCN6186_ VOCON Spark Gaps

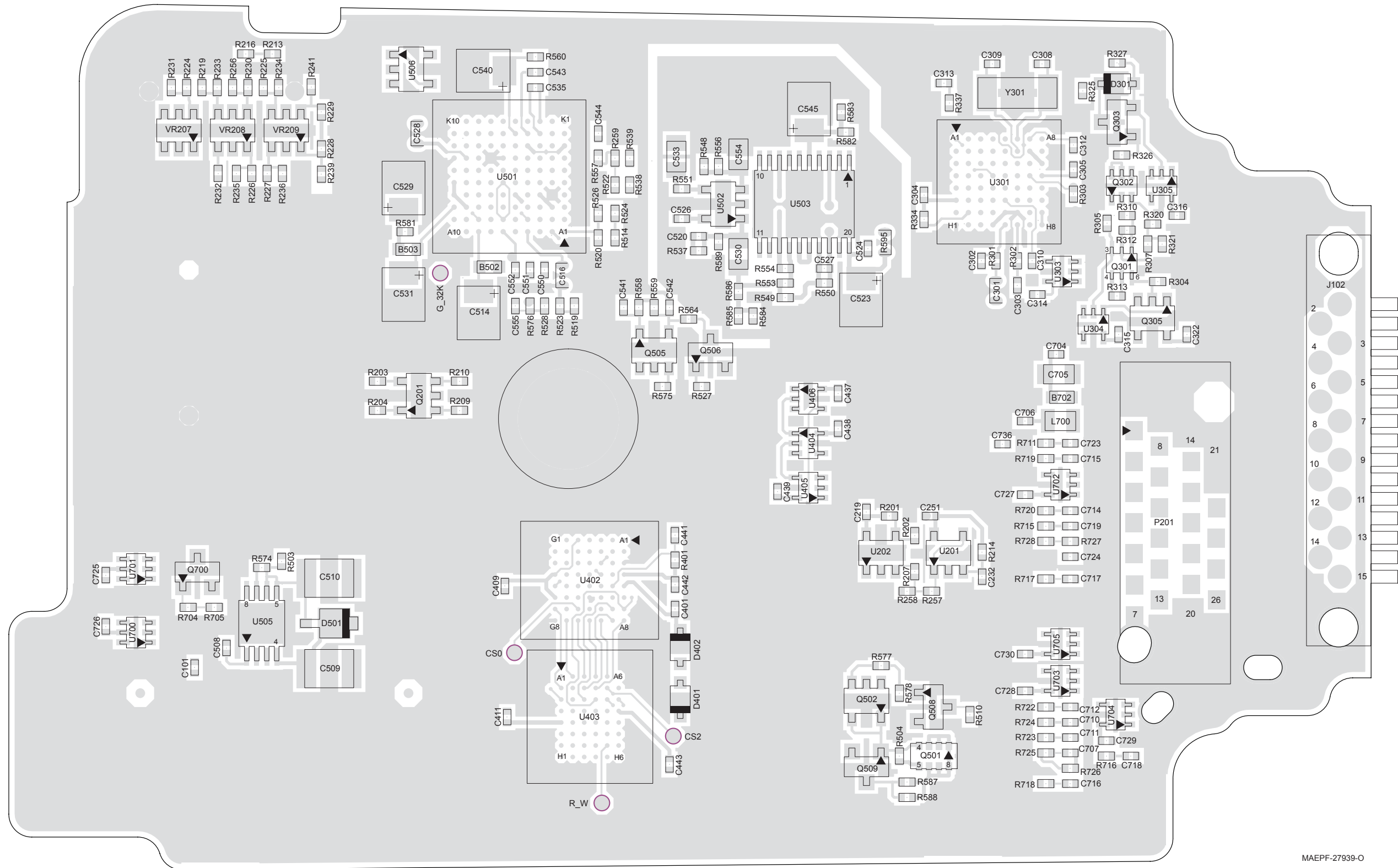


Figure 12-21. NCN6186_ VOCON Board Layout—Side 1



MAEPF-27938-O

Figure 12-22. NCN6186_ VOCON Board Layout—Side 2



MAEPF-27939-O

NCN6186_VOCON Board Parts List

Ref. Des.	Motorola Part Number	Description
B401	2480574F01	IND FERRITE CHIP 600 OHM 0603
B402	2480574F01	IND FERRITE CHIP 600 OHM 0603
B502	2480574F01	IND FERRITE CHIP 600 OHM 0603
B503	2480574F01	IND FERRITE CHIP 600 OHM 0603
B700	2480574F01	IND FERRITE CHIP 600 OHM 0603
B702	2462586G33	INDUCTOR CHIP FERRITE BEADS
C101	2113743L09	CAP CHIP 470 PF 10% X7R
C102	2113743L09	CAP CHIP 470 PF 10% X7R
C201	2113743L09	CAP CHIP 470 PF 10% X7R
C202	2113743L09	CAP CHIP 470 PF 10% X7R
C203	2113743L09	CAP CHIP 470 PF 10% X7R
C204	2113743L09	CAP CHIP 470 PF 10% X7R
C205	2113743L41	CAP CHIP 10000 PF 10% X7R
C206	2113743L41	CAP CHIP 10000 PF 10% X7R
C207	NOTPLACED	64AM DUMMY PART NUMBER
C209	2113743L41	CAP CHIP 10000 PF 10% X7R
C212	2113743L09	CAP CHIP 470 PF 10% X7R
C214	2113743L09	CAP CHIP 470 PF 10% X7R
C215	2113743L09	CAP CHIP 470 PF 10% X7R
C216	2113743L09	CAP CHIP 470 PF 10% X7R
C217	2113743L09	CAP CHIP 470 PF 10% X7R
C218	2113743L09	CAP CHIP 470 PF 10% X7R
C219	2113743M24	CAP CHIP 100000 PF +80-20% Y5V
C224	2113743N38	CAP CHIP 33.0 PF 5% COG
C225	2113743L09	CAP CHIP 470 PF 10% X7R
C226	2113743N38	CAP CHIP 33.0 PF 5% COG
C227	2113743L09	CAP CHIP 470 PF 10% X7R
C232	2113743N50	CAP CHIP 100 PF 5% COG
C233	2113743N50	CAP CHIP 100 PF 5% COG
C234	2113743M24	CAP CHIP 100000 PF +80-20% Y5V
C236	2113743N50	CAP CHIP 100 PF 5% COG

Ref. Des.	Motorola Part Number	Description
C237	2113743L09	CAP CHIP 470 PF 10% X7R
C238	2113743L09	CAP CHIP 470 PF 10% X7R
C239	2113743L09	CAP CHIP 470 PF 10% X7R
C240	2113743L09	CAP CHIP 470 PF 10% X7R
C241	2113743M24	CAP CHIP 100000 PF +80-20% Y5V
C251	2113743M24	CAP CHIP 100000 PF +80-20% Y5V
C301	2113743E20	CAP CHIP .10 UF 10%
C302	2113743L41	CAP CHIP 10000 PF 10% X7R
C303	2113743N38	CAP CHIP 33.0 PF 5% COG
C304	2113743M24	CAP CHIP 100000 PF +80-20% Y5V
C305	2113743M24	CAP CHIP 100000 PF +80-20% Y5V
C308	2113743N20	CAP CHIP 5.6 PF + .5PF COG
C309	2113743N20	CAP CHIP 5.6 PF + .5PF COG
C310	2113743M24	CAP CHIP 100000 PF +80-20% Y5V
C312	2113743M24	CAP CHIP 100000 PF +80-20% Y5V
C313	2113743N28	CAP CHIP 12.0 PF 5% COG
C314	2113743M24	CAP CHIP 100000 PF +80-20% Y5V
C315	2113743M24	CAP CHIP 100000 PF +80-20% Y5V
C316	2113743M24	CAP CHIP 100000 PF +80-20% Y5V
C317	2113743M24	CAP CHIP 100000 PF +80-20% Y5V
C319	2113743M24	CAP CHIP 100000 PF +80-20% Y5V
C320	2113743M24	CAP CHIP 100000 PF +80-20% Y5V
C322	2113743M24	CAP CHIP 100000 PF +80-20% Y5V
C324	2113743M24	CAP CHIP 100000 PF +80-20% Y5V
C325	2113743M24	CAP CHIP 100000 PF +80-20% Y5V
C326	2113743M24	CAP CHIP 100000 PF +80-20% Y5V

Ref. Des.	Motorola Part Number	Description
C327	2113743M24	CAP CHIP 100000 PF +80-20% Y5V
C401	2113743M24	CAP CHIP 100000 PF +80-20% Y5V
C409	2113743M24	CAP CHIP 100000 PF +80-20% Y5V
C411	2113743M24	CAP CHIP 100000 PF +80-20% Y5V
C416	2113743M24	CAP CHIP 100000 PF +80-20% Y5V
C417	2113743E04	CER CHIP CAP .016UF
C418	2113743A31	CAP CHIP 1.0 UF 10% X7R
C419	2113743N50	CAP CHIP 100 PF 5% COG
C420	2113743N50	CAP CHIP 100 PF 5% COG
C421	2113743A31	CAP CHIP 1.0 UF 10% X7R
C422	2113743M24	CAP CHIP 100000 PF +80-20% Y5V
C423	2113743M24	CAP CHIP 100000 PF +80-20% Y5V
C424	2113743E04	CER CHIP CAP .016UF
C425	2113743M24	CAP CHIP 100000 PF +80-20% Y5V
C426	2113743M24	CAP CHIP 100000 PF +80-20% Y5V
C427	2113743M24	CAP CHIP 100000 PF +80-20% Y5V
C428	2113743M24	CAP CHIP 100000 PF +80-20% Y5V
C437	2113743M24	CAP CHIP 100000 PF +80-20% Y5V
C438	2113743M24	CAP CHIP 100000 PF +80-20% Y5V
C439	2113743M24	CAP CHIP 100000 PF +80-20% Y5V
C440	2113743N50	CAP CHIP 100 PF 5% COG
C441	2113743L09	CAP CHIP 470 PF 10% X7R
C442	2113743M24	CAP CHIP 100000 PF +80-20% Y5V
C443	2113743M24	CAP CHIP 100000 PF +80-20% Y5V
C444	2113743E04	CER CHIP CAP .016UF
C445	2113743A31	CAP CHIP 1.0 UF 10% X7R

Ref. Des.	Motorola Part Number	Description
C446	2113743M24	CAP CHIP 100000 PF +80-20% Y5V
C502	2113743N50	CAP CHIP 100 PF 5% COG
C503	2113743N50	CAP CHIP 100 PF 5% COG
C504	2311049C52	CAP TANT CHIP 33UF 10% 10V
C505	2113743N50	CAP CHIP 100 PF 5% COG
C506	2311049C52	CAP TANT CHIP 33UF 10% 10V
C507	2113743N50	CAP CHIP 100 PF 5% COG
C508	2113743L41	CAP CHIP 10000 PF 10% X7R
C509	2113743T19	CAP 10UF 16V CER 3225 X5R
C510	2113743T19	CAP 10UF 16V CER 3225 X5R
C514	2311049A57	CAP TANT CHIP A/P 10UF 10% 16V
C516	2113743E11	CAP CHIP .039 UF 10% X7R
C519	2311049A57	CAP TANT CHIP A/P 10UF 10% 16V
C520	2113743L05	CAP CHIP 330 PF 10% X7R
C521	2113743N50	CAP CHIP 100 PF 5% COG
C522	2113743A31	CAP CHIP 1.0 UF 10% X7R
C523	2311049A57	CAP TANT CHIP A/P 10UF 10% 16V
C524	2113743M24	CAP CHIP 100000 PF +80-20% Y5V
C525	2113743N50	CAP CHIP 100 PF 5% COG
C526	2113743M24	CAP CHIP 100000 PF +80-20% Y5V
C527	NOTPLACED	64AM DUMMY PART NUMBER
C528	2113743E11	CAP CHIP .039 UF 10% X7R
C529	2311049A57	CAP TANT CHIP A/P 10UF 10% 16V
C530	2113743A19	CAP CHIP .100 UF 10% X7R
C531	2311049A57	CAP TANT CHIP A/P 10UF 10% 16V
C532	2113743M24	CAP CHIP 100000 PF +80-20% Y5V
C533	2113743A31	CAP CHIP 1.0 UF 10% X7R
C535	2113743M24	CAP CHIP 100000 PF +80-20% Y5V
C540	2311049A57	CAP TANT CHIP A/P 10UF 10% 16V

Ref. Des.	Motorola Part Number	Description
C541	2113743M24	CAP CHIP 100000 PF +80-20% Y5V
C542	2113743M24	CAP CHIP 100000 PF +80-20% Y5V
C543	2113743M24	CAP CHIP 100000 PF +80-20% Y5V
C544	2113743M24	CAP CHIP 100000 PF +80-20% Y5V
C545	2311049A57	CAP TANT CHIP A/P 10UF 10% 16V
C546	2113743N50	CAP CHIP 100 PF 5% COG
C547	2311049A57	CAP TANT CHIP A/P 10UF 10% 16V
C548	2113743N50	CAP CHIP 100 PF 5% COG
C549	2113743A31	CAP CHIP 1.0 UF 10% X7R
C550	2113743M24	CAP CHIP 100000 PF +80-20% Y5V
C551	2113743M24	CAP CHIP 100000 PF +80-20% Y5V
C552	2113743M24	CAP CHIP 100000 PF +80-20% Y5V
C554	2113743A31	CAP CHIP 1.0 UF 10% X7R
C555	2113743M24	CAP CHIP 100000 PF +80-20% Y5V
C600	2113743N50	CAP CHIP 100 PF 5% COG
C601	2113743L50	CAP CHIP 33000 PF 10%
C603	2113743M24	CAP CHIP 100000 PF +80-20% Y5V
C604	2113928C04	CAP CER CHIP 4.7UF 6.3V10%0805
C605	2113743N50	CAP CHIP 100 PF 5% COG
C606	2113743M24	CAP CHIP 100000 PF +80-20% Y5V
C607	2113928E01	CAP CER CHIP 1.0 UF 10 % 10V
C608	2113743M24	CAP CHIP 100000 PF +80-20% Y5V
C609	2113743N50	CAP CHIP 100 PF 5% COG
C700	2113743L09	CAP CHIP 470 PF 10% X7R
C703	NOTPLACED	64AM DUMMY PART NUMBER
C704	2113743N50	CAP CHIP 100 PF 5% COG
C705	2113743A31	CAP CHIP 1.0 UF 10% X7R
C706	2113743L09	CAP CHIP 470 PF 10% X7R

Ref. Des.	Motorola Part Number	Description
C707	2113743L09	CAP CHIP 470 PF 10% X7R
C710	2113743L09	CAP CHIP 470 PF 10% X7R
C711	2113743L09	CAP CHIP 470 PF 10% X7R
C712	2113743L09	CAP CHIP 470 PF 10% X7R
C714	2113743N50	CAP CHIP 100 PF 5% COG
C715	2113743N50	CAP CHIP 100 PF 5% COG
C716	2113743L09	CAP CHIP 470 PF 10% X7R
C717	2113743N50	CAP CHIP 100 PF 5% COG
C718	2113743L09	CAP CHIP 470 PF 10% X7R
C719	2113743N50	CAP CHIP 100 PF 5% COG
C723	2113743N50	CAP CHIP 100 PF 5% COG
C724	2113743N50	CAP CHIP 100 PF 5% COG
C725	2113743M24	CAP CHIP 100000 PF +80-20% Y5V
C726	2113743M24	CAP CHIP 100000 PF +80-20% Y5V
C727	2113743M24	CAP CHIP 100000 PF +80-20% Y5V
C728	2113743M24	CAP CHIP 100000 PF +80-20% Y5V
C729	2113743M24	CAP CHIP 100000 PF +80-20% Y5V
C730	2113743M24	CAP CHIP 100000 PF +80-20% Y5V
C732	2113743N50	CAP CHIP 100 PF 5% COG
C733	2113743N50	CAP CHIP 100 PF 5% COG
C734	2113743N50	CAP CHIP 100 PF 5% COG
C735	2113743N50	CAP CHIP 100 PF 5% COG
C736	2113743N50	CAP CHIP 100 PF 5% COG
D201	4805729G99	LED STANLEY BICOLOR RED-GREEN LED
D202	4805656W37	TSTR BAT54HT1
D203	4802021P15	ZENER SR05
D207	4805656W37	TSTR BAT54HT1
D301	4805656W37	TSTR BAT54HT1
D302	4805656W37	TSTR BAT54HT1
D303	4805656W37	TSTR BAT54HT1
D401	4805656W37	TSTR BAT54HT1
D402	4805656W37	TSTR BAT54HT1
D501	4813833A20	DIODE SCHOTTKY 1A 40V PWRMITE

Ref. Des.	Motorola Part Number	Description
D502	4813833A20	DIODE SCHOTTKY 1A 40V PWRMITE
D503	4813833A20	DIODE SCHOTTKY 1A 40V PWRMITE
D601	4813830A15	DIODE 5.6V 5% 225MW MMBZ5232B_
D602	4805656W37	TSTR BAT54HT1
D603	4805129M06	DIODE MMBD7000
J102	2802624J02	CONNECTOR, COMPRESSION SPRING
J301	0980423L08	CONN, STACKING, F, 20, 2ROWS, 8MMPITC
J701	0980423L02	CONN 40 POS PAK-8
J707	0980423L08	CONN, STACKING, F, 20, 2ROWS, 8MMPITC
L201	2404574Z14	IND CHIP WW 270NH 2% 2012 SMD
L202	2404574Z14	IND CHIP WW 270NH 2% 2012 SMD
L203	2404574Z14	IND CHIP WW 270NH 2% 2012 SMD
L207	2404574Z14	IND CHIP WW 270NH 2% 2012 SMD
L208	2404574Z14	IND CHIP WW 270NH 2% 2012 SMD
L501	2486085A06	COIL 47UH SMT POWER INDUCTOR
L502	2486085A06	COIL 47UH SMT POWER INDUCTOR
L601	2462587N68	CHIP IND 1000 NH 5%
L700	2404574Z14	IND CHIP WW 270NH 2% 2012 SMD
M102	3987522K04	CONN, CONTACT BLOCK BATT
PCB	8485270E01	BD CKT VOCON
Q201	4805921T09	XSTR DUAL ROHM FMG8
Q203	4805723X03	TRANS DUAL NPN-PNP UMD3N ROHM
Q204	4805723X03	TRANS DUAL NPN-PNP UMD3N ROHM
Q301	4809579E35	TSTR FET DUAL N-CHAN FDG3601N
Q302	4805723X03	TRANS DUAL NPN-PNP UMD3N ROHM

Ref. Des.	Motorola Part Number	Description
Q303	4813824A10	TSTR NPN 40V .2A GEN PURP
Q304	4813824A10	TSTR NPN 40V .2A GEN PURP
Q305	5185143E74	IC SINGLE FET BUS SWITCH
Q306	4813824A10	TSTR NPN 40V .2A GEN PURP
Q501	4885844C01	XSTR FET
Q502	4805921T09	XSTR DUAL ROHM FMG8
Q505	4805921T09	XSTR DUAL ROHM FMG8
Q506	4813824A10	TSTR NPN 40V .2A GEN PURP
Q508	4813824A10	TSTR NPN 40V .2A GEN PURP
Q509	4805218N11	XISTOR SOT RH BST82
Q600	4813824A13	XSTR NPN 80V .5A DRIVER B=50
Q601	4805793Y01	TRANS MINI SOT NPN LOW NOISE
Q602	4805723X03	TRANS DUAL NPN-PNP UMD3N ROHM
Q603	4805793Y01	TRANS MINI SOT NPN LOW NOISE
Q700	4813824A10	TSTR NPN 40V .2A GEN PURP
R101	0662057M01	RES. CHIP 0 5% 20X40
R102	NOTPLACED	64AM DUMMY PART NUMBER
R201	0662057V35	RES CHIP 200K 1% 1/16W
R202	0662057N06	RES. CHIP 20K 5% 20X40
R203	0662057M61	RES. CHIP 300 5% 20X40
R204	0662057M60	RES. CHIP 270 5% 20X40
R205	0662057M98	RES. CHIP 10K 5% 20X40
R207	0662057M01	RES. CHIP 0 5% 20X40
R209	0662057M98	RES. CHIP 10K 5% 20X40
R210	0662057M98	RES. CHIP 10K 5% 20X40
R211	0662057N23	RES. CHIP 100K 5% 20X40
R212	0662057M46	RES. CHIP 68 5% 20X40
R213	0662057N15	RES. CHIP 47K 5% 20X40
R214	0662057N06	RES. CHIP 20K 5% 20X40
R215	0662057M98	RES. CHIP 10K 5% 20X40
R216	0662057M90	RES. CHIP 4700 5% 20X40

Ref. Des.	Motorola Part Number	Description
R217	0662057M01	RES. CHIP 0 5% 20X40
R218	0662057M64	RES. CHIP 390 5% 20X40
R219	0662057M98	RES. CHIP 10K 5% 20X40
R224	0662057N17	RES. CHIP 56K 5% 20X40
R225	0662057M98	RES. CHIP 10K 5% 20X40
R226	0662057M98	RES. CHIP 10K 5% 20X40
R227	0662057M98	RES. CHIP 10K 5% 20X40
R228	0662057M98	RES. CHIP 10K 5% 20X40
R229	0662057M98	RES. CHIP 10K 5% 20X40
R230	0662057M98	RES. CHIP 10K 5% 20X40
R231	0662057M74	RES. CHIP 1000 5% 20X40
R232	0662057M74	RES. CHIP 1000 5% 20X40
R233	0662057M74	RES. CHIP 1000 5% 20X40
R234	0662057M74	RES. CHIP 1000 5% 20X40
R235	0662057M74	RES. CHIP 1000 5% 20X40
R236	0662057M74	RES. CHIP 1000 5% 20X40
R237	0662057M56	RES. CHIP 180 5% 20X40
R239	0662057M74	RES. CHIP 1000 5% 20X40
R241	0662057M74	RES. CHIP 1000 5% 20X40
R242	0662057M64	RES. CHIP 390 5% 20X40
R245	0662057M74	RES. CHIP 1000 5% 20X40
R248	0662057M74	RES. CHIP 1000 5% 20X40
R249	0662057N39	RES. CHIP 470K 5% 20X40
R252	0662057M38	RES. CHIP 33 5% 20X40
R253	0662057M38	RES. CHIP 33 5% 20X40
R255	0662057M50	RES. CHIP 100 5% 20X40
R256	0662057M74	RES. CHIP 1000 5% 20X40
R257	0662057V02	RES CHIP 10K 1% 1/16W
R258	0662057V02	RES CHIP 10K 1% 1/16W
R259	0662057M98	RES. CHIP 10K 5% 20X40
R301	0662057M67	RES. CHIP 510 5% 20X40
R302	0662057M74	RES. CHIP 1000 5% 20X40
R303	0662057M98	RES. CHIP 10K 5% 20X40
R304	0662057N39	RES. CHIP 470K 5% 20X40
R305	0662057N39	RES. CHIP 470K 5% 20X40
R307	0662057M98	RES. CHIP 10K 5% 20X40
R310	0662057M78	RES. CHIP 1500 5% 20X40
R312	0662057N47	RES. CHIP 1.0 MEG 5% 20X40

Ref. Des.	Motorola Part Number	Description
R313	0662057N47	RES. CHIP 1.0 MEG 5% 20X40
R320	0662057N47	RES. CHIP 1.0 MEG 5% 20X40
R321	0662057M98	RES. CHIP 10K 5% 20X40
R325	0662057M98	RES. CHIP 10K 5% 20X40
R326	0662057M98	RES. CHIP 10K 5% 20X40
R327	0662057N23	RES. CHIP 100K 5% 20X40
R328	0662057M98	RES. CHIP 10K 5% 20X40
R329	0662057N23	RES. CHIP 100K 5% 20X40
R330	0662057M98	RES. CHIP 10K 5% 20X40
R331	0662057M98	RES. CHIP 10K 5% 20X40
R332	0662057N23	RES. CHIP 100K 5% 20X40
R333	0662057M98	RES. CHIP 10K 5% 20X40
R334	0662057M01	RES. CHIP 0 5% 20X40
R336	NOTPLACED	64AM DUMMY PART NUMBER
R337	0662057M50	RES. CHIP 100 5% 20X40
R400	0662057B47	CHIP RES 0 OHMS +/-0.50 OHMS
R401	0662057M90	RES. CHIP 4700 5% 20X40
R402	0662057M01	RES. CHIP 0 5% 20X40
R403	0662057M01	RES. CHIP 0 5% 20X40
R405	0662057M01	RES. CHIP 0 5% 20X40
R406	0662057M01	RES. CHIP 0 5% 20X40
R410	NOTPLACED	64AM DUMMY PART NUMBER
R414	0662057M98	RES. CHIP 10K 5% 20X40
R415	0662057M98	RES. CHIP 10K 5% 20X40
R416	0662057M98	RES. CHIP 10K 5% 20X40
R417	NOTPLACED	64AM DUMMY PART NUMBER
R418	0662057M01	RES. CHIP 0 5% 20X40
R419	NOTPLACED	64AM DUMMY PART NUMBER
R501	0662057M01	RES. CHIP 0 5% 20X40
R502	0662057M01	RES. CHIP 0 5% 20X40
R503	0662057M01	RES. CHIP 0 5% 20X40
R504	0662057N06	RES. CHIP 20K 5% 20X40
R510	0662057M98	RES. CHIP 10K 5% 20X40
R514	0662057N06	RES. CHIP 20K 5% 20X40
R519	0662057M98	RES. CHIP 10K 5% 20X40
R520	0662057U84	RES CHIP 2K 1% 1/16W
R522	0662057N15	RES. CHIP 47K 5% 20X40

Ref. Des.	Motorola Part Number	Description
R523	0662057N15	RES. CHIP 47K 5% 20X40
R524	0662057M94	RES. CHIP 6800 5% 20X40
R526	0662057V02	RES CHIP 10K 1% 1/16W
R527	0662057M74	RES. CHIP 1000 5% 20X40
R528	0662057M74	RES. CHIP 1000 5% 20X40
R531	0662057M64	RES. CHIP 390 5% 20X40
R533	0662057M82	RES. CHIP 2200 5% 20X40
R537	0662057N10	RES. CHIP 30K 5% 20X40
R538	0662057M01	RES. CHIP 0 5% 20X40
R539	0662057M01	RES. CHIP 0 5% 20X40
R540	0662057M95	RES. CHIP 7500 5% 20X40
R548	0662057N06	RES. CHIP 20K 5% 20X40
R549	0662057M96	RES. CHIP 8200 5% 20X40
R550	0662057V25	RES CHIP 82K 1% 1/16
R551	0662057N06	RES. CHIP 20K 5% 20X40
R553	0662057M96	RES. CHIP 8200 5% 20X40
R554	0662057V25	RES CHIP 82K 1% 1/16
R555	0662057M74	RES. CHIP 1000 5% 20X40
R556	0662057N06	RES. CHIP 20K 5% 20X40
R557	0662057M98	RES. CHIP 10K 5% 20X40
R558	0662057M94	RES. CHIP 6800 5% 20X40
R559	0662057M98	RES. CHIP 10K 5% 20X40
R560	0662057M01	RES. CHIP 0 5% 20X40
R561	0662057M74	RES. CHIP 1000 5% 20X40
R563	0662057M64	RES. CHIP 390 5% 20X40
R564	0662057M98	RES. CHIP 10K 5% 20X40
R565	0662057M82	RES. CHIP 2200 5% 20X40
R566	0662057M95	RES. CHIP 7500 5% 20X40
R574	0662057N23	RES. CHIP 100K 5% 20X40
R575	0662057M98	RES. CHIP 10K 5% 20X40
R576	0662057N23	RES. CHIP 100K 5% 20X40
R577	0662057N15	RES. CHIP 47K 5% 20X40
R578	0662057N15	RES. CHIP 47K 5% 20X40
R581	0662057M10	RES CHIP 2.2 5% 20X40
R582	0662057M90	RES. CHIP 4700 5% 20X40
R583	0662057M90	RES. CHIP 4700 5% 20X40
R584	0662057M98	RES. CHIP 10K 5% 20X40
R585	0662057M98	RES. CHIP 10K 5% 20X40

Ref. Des.	Motorola Part Number	Description
R586	0662057N39	RES. CHIP 470K 5% 20X40
R587	0662057M34	RES. CHIP 22 5% 20X40
R588	0662057M34	RES. CHIP 22 5% 20X40
R589	0662057M98	RES. CHIP 10K 5% 20X40
R595	0662057B47	CHIP RES 0 OHMS +/-0.50 OHMS
R600	0662057M71	RES CHIP 750 5% 20X40
R601	0662057V04	RES CHIP 12K 1% 1/16W
R602	0662057U60	RES CHIP 220 1% 1/16w
R603	0662057M96	RES. CHIP 8200 5% 20X40
R605	0662057N11	RES. CHIP 33K 5% 20X40
R608	0662057M64	RES. CHIP 390 5% 20X40
R609	0662057M50	RES. CHIP 100 5% 20X40
R610	0662057N23	RES. CHIP 100K 5% 20X40
R611	0662057M90	RES. CHIP 4700 5% 20X40
R612	0662057M98	RES. CHIP 10K 5% 20X40
R613	0662057N23	RES. CHIP 100K 5% 20X40
R615	0662057M42	RES. CHIP 47 5% 20X40
R617	0662057V02	RES CHIP 10K 1% 1/16W
R702	0662057M56	RES. CHIP 180 5% 20X40
R703	0662057M56	RES. CHIP 180 5% 20X40
R704	0662057M90	RES. CHIP 4700 5% 20X40
R705	0662057M98	RES. CHIP 10K 5% 20X40
R709	0662057M50	RES. CHIP 100 5% 20X40
R710	NOTPLACED	64AM DUMMY PART NUMBER
R711	0662057M50	RES. CHIP 100 5% 20X40
R715	0662057M50	RES. CHIP 100 5% 20X40
R716	0662057M50	RES. CHIP 100 5% 20X40
R717	0662057M50	RES. CHIP 100 5% 20X40
R718	0662057M50	RES. CHIP 100 5% 20X40
R719	0662057M50	RES. CHIP 100 5% 20X40
R720	0662057M50	RES. CHIP 100 5% 20X40
R722	0662057M50	RES. CHIP 100 5% 20X40
R723	0662057M50	RES. CHIP 100 5% 20X40
R724	0662057M50	RES. CHIP 100 5% 20X40
R725	0662057M74	RES. CHIP 1000 5% 20X40
R726	0662057M98	RES. CHIP 10K 5% 20X40
R727	0662057M74	RES. CHIP 1000 5% 20X40

Ref. Des.	Motorola Part Number	Description
R728	0662057M98	RES. CHIP 10K 5% 20X40
SH401	2685752E01	SHIELD SUB PATRIOT
SH500	2685533E01	SHEILD
SH600	NOTPLACED	64AM DUMMY PART NUMBER
U201	5109731C15	IC OP AMP SNGL OPA237 SOT23
U202	5109731C15	IC OP AMP SNGL OPA237 SOT23
U301	5185368C66	IC CUSTOM FLIPPER
U302	5187970L15	IC USB TRANS FULL-SPEED
U303	5109522E53	IC SNGL BUF NC7S125P5X SC70
U304	5109522E53	IC SNGL BUF NC7S125P5X SC70
U305	5109522E53	IC SNGL BUF NC7S125P5X SC70
U306	5109522E53	IC SNGL BUF NC7S125P5X SC70
U308	5109522E53	IC SNGL BUF NC7S125P5X SC70
U309	5185368C12	IC 1.8V SN LOGIC GATE
U312	5105492X03	IC SNG HI SPD L-MOS NOT GATE
U401	5185956E51	IC PATRIOT BRAVO 1.0.2
U402	5185956E16	IC FLASH 32MB 1.8V 60NS
U403	5185130C38	IC SRAM 4MG
U404	5109522E53	IC SNGL BUF NC7S125P5X SC70
U405	5109522E53	IC SNGL BUF NC7S125P5X SC70
U406	5105492X03	IC SNG HI SPD L-MOS NOT GATE
U407	5109522E53	IC SNGL BUF NC7S125P5X SC70
U501	5109879E58	IC, COMP, AUDIO AND POWER MANAGEMENT
U502	5109731C15	IC OP AMP SNGL OPA237 SOT23
U503	5102463J44	AUDIO AMPLIFIER TDA8547TS
U505	5185353D13	IC MINI SO-8 HI PRECISION REG 5V

Ref. Des.	Motorola Part Number	Description
U506	5109731C15	IC OP AMP SNGL OPA237 SOT23
U509	5185353D35	IC DUAL EEPOT 256 TAP
U600	5113816A73	IC ADJST 1.7% TOL SHUNT REG 20MA
U601	5105492X92	IC CMOS BILATERAL SWITCH
U700	5109817F62	IC SPDT SWITCH/ MULTIPLEXER
U701	5109817F62	IC SPDT SWITCH/ MULTIPLEXER
U702	5109522E53	IC SNGL BUF NC7S125P5X SC70
U703	5109522E53	IC SNGL BUF NC7S125P5X SC70
U704	5109522E53	IC SNGL BUF NC7S125P5X SC70
U705	5109522E53	IC SNGL BUF NC7S125P5X SC70
VR201	4813832C72	TRANS SUP QUAD 12V
VR202	4813830A22	DIODE 9.1V 5% 225MW MMBZ5239B_
VR204	4813830C26	DIODE 13V 'H3' MMSZ5243BT1
VR205	4805656W08	DIODE ZENER QUAD
VR206	4805656W08	DIODE ZENER QUAD
VR207	4805656W08	DIODE ZENER QUAD
VR208	4805656W08	DIODE ZENER QUAD
VR209	4805656W08	DIODE ZENER QUAD
VR220	4805656W03	DIODE DUAL 5.6V ZENER
VR221	4805656W03	DIODE DUAL 5.6V ZENER
Y301	4809995L05	XTAL QUARTZ 32.768KHZ CC4V-T1

12.3 Control Flex

Figure 12-23. Control Flex Overall Circuit Schematic

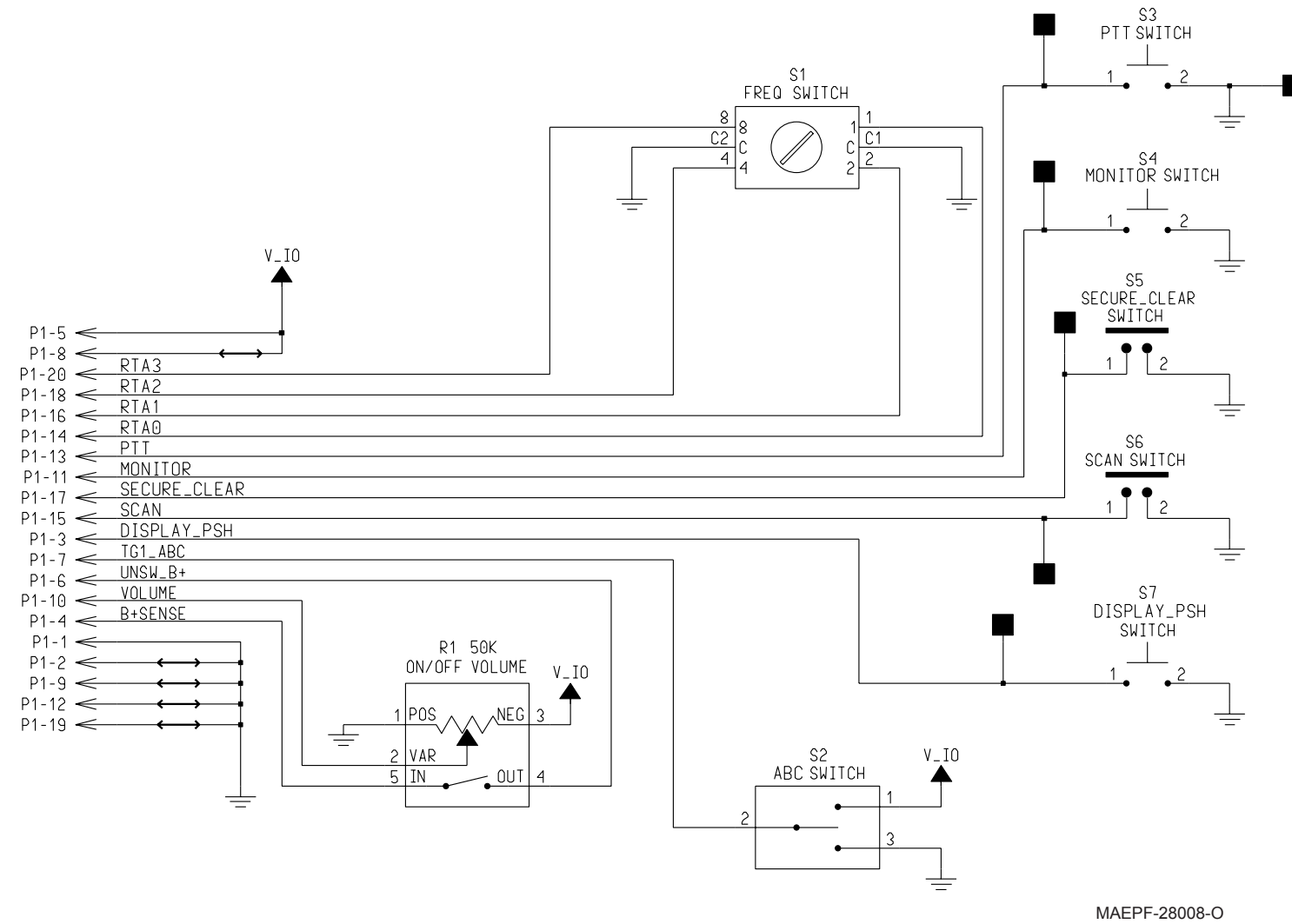
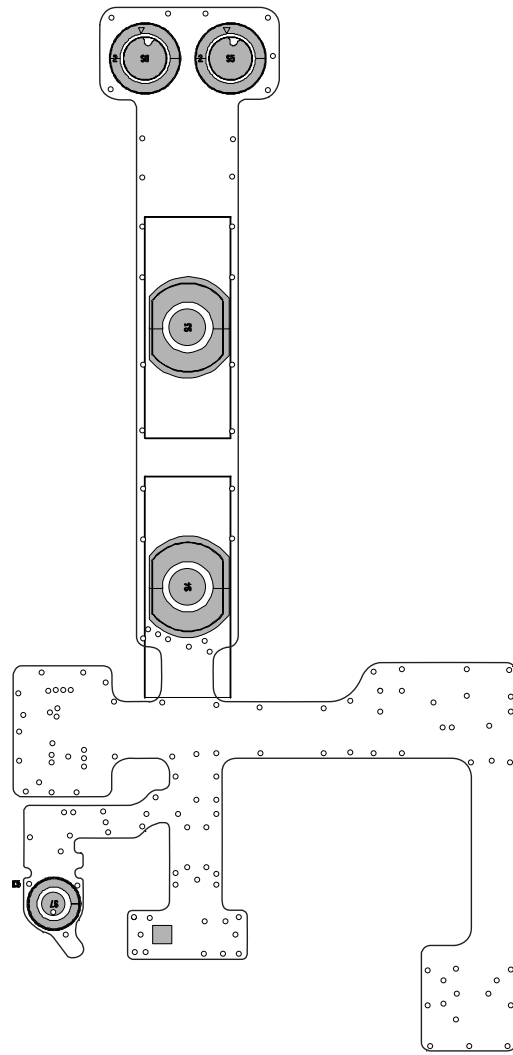
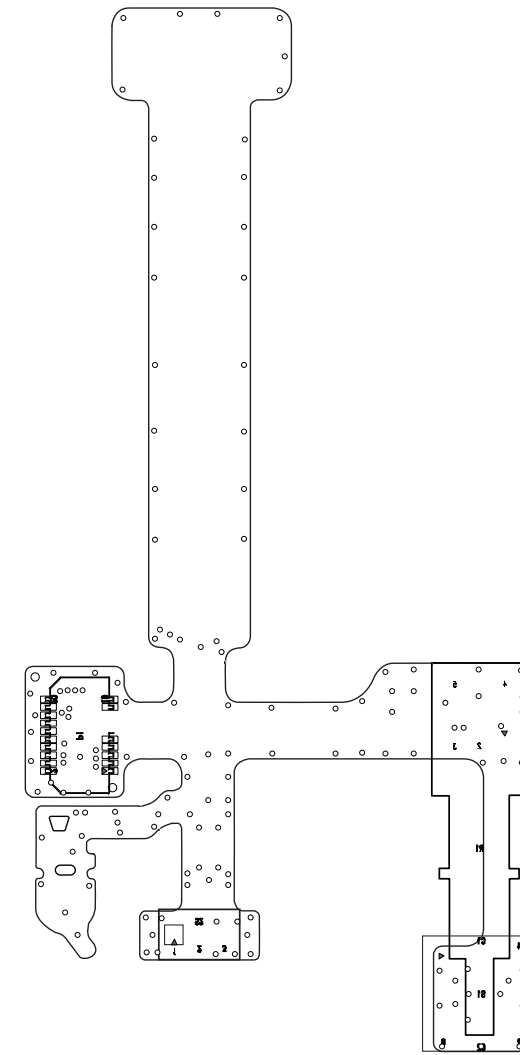


Figure 12-24. Control Flex Board Layout—Side 1



MAEPF-28009-O

Figure 12-25. Control Flex Board Layout—Side 2



MAEPF-28007-O

12.4 Universal Flex

Figure 12-26. Universal Flex Overall Circuit Schematic

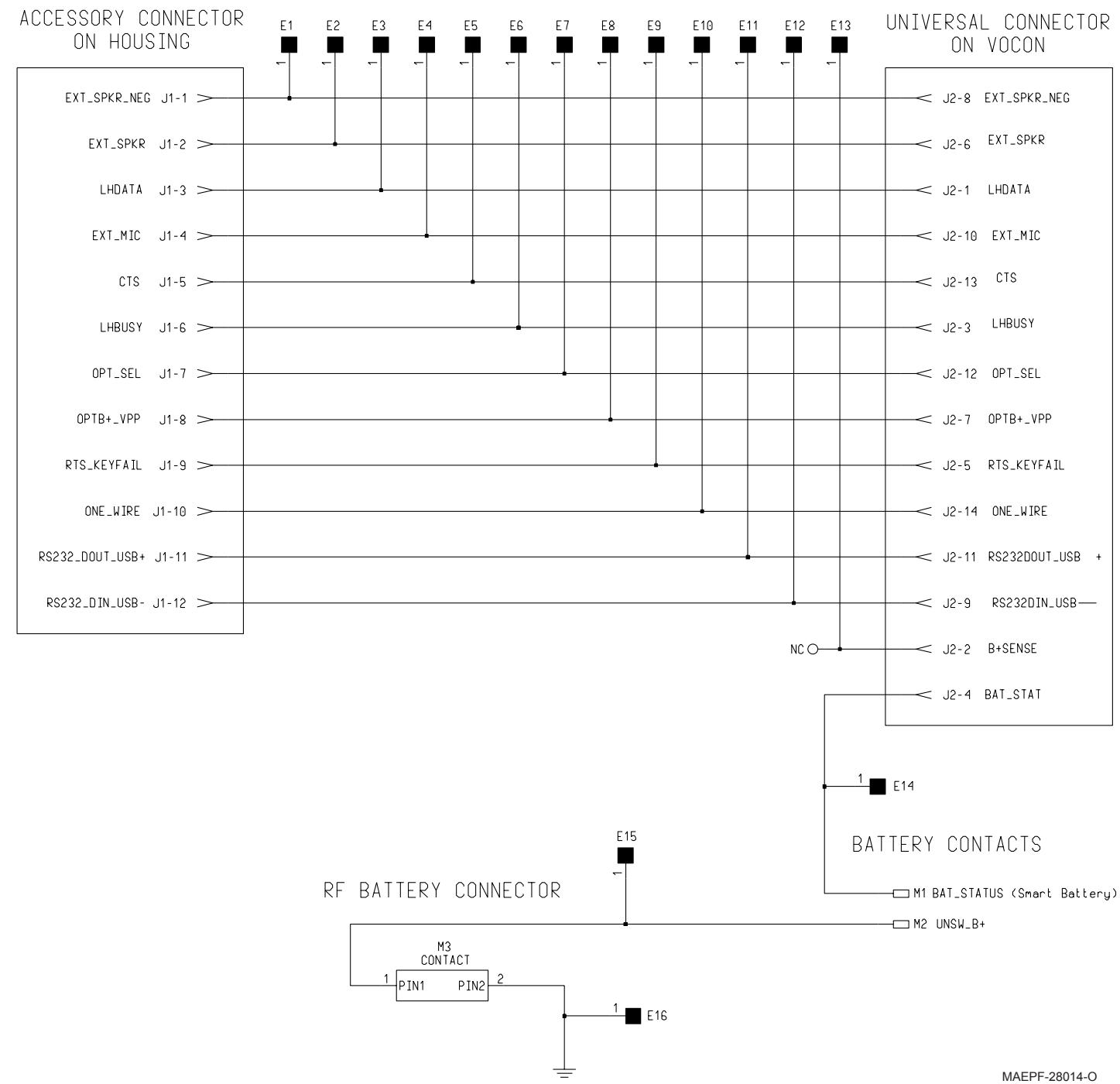


Figure 12-27. Universal Flex Board Layout—Side 1

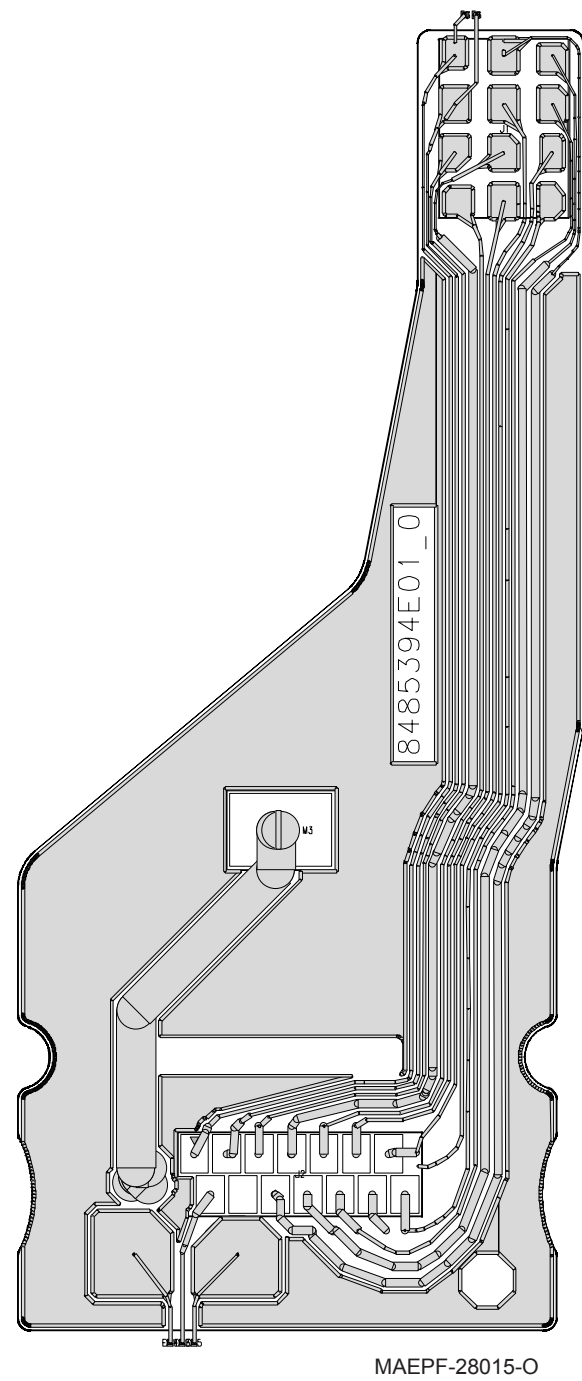
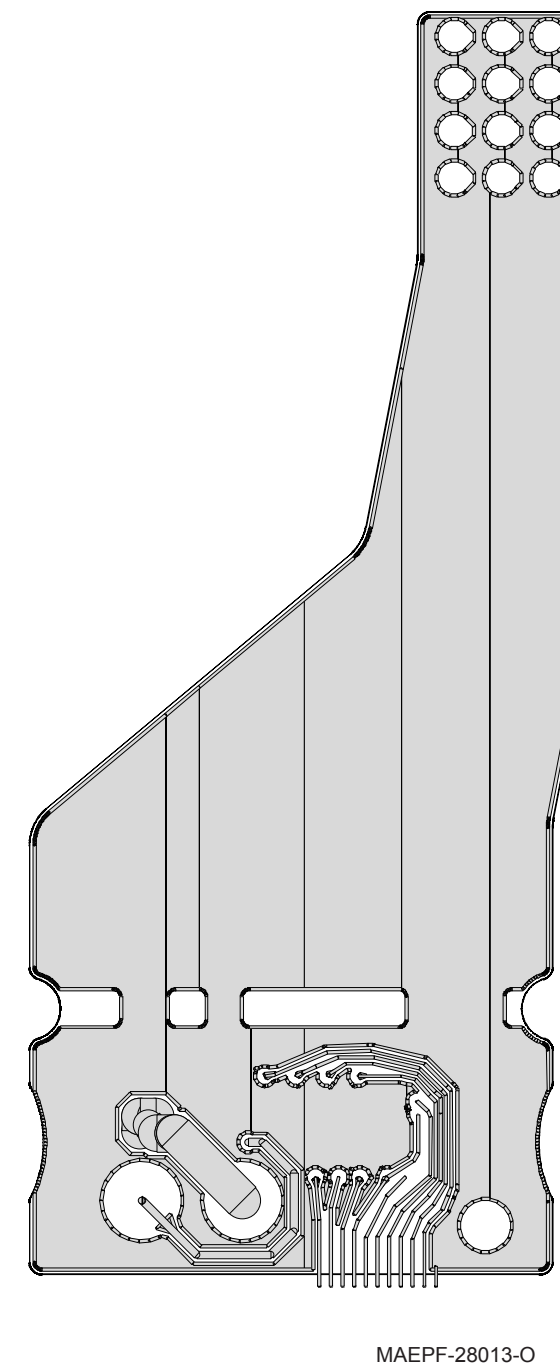
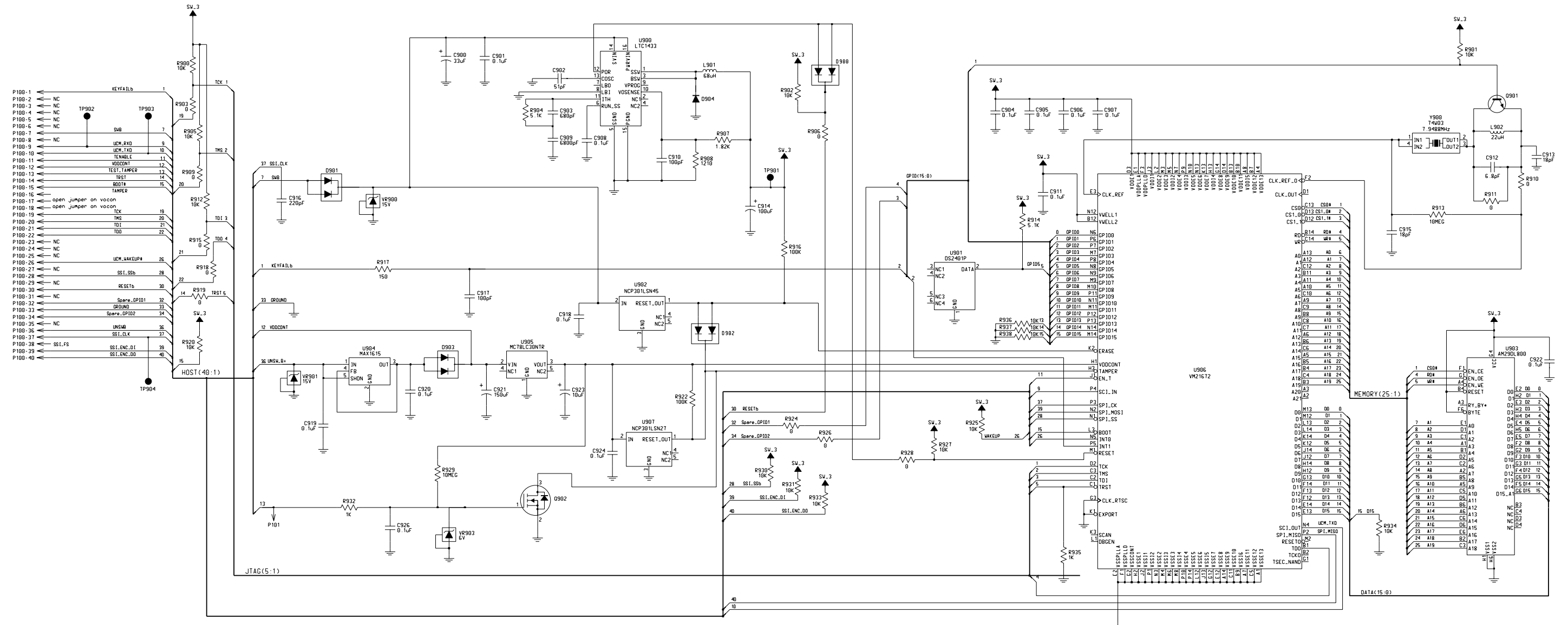


Figure 12-28. Universal Flex Board Layout—Side 2



12.5 UCM

Figure 12-29. UCM Flex Overall Circuit Schematic



MAEPF-28011-O

Figure 12-30. UCM Board Layout—Side 1

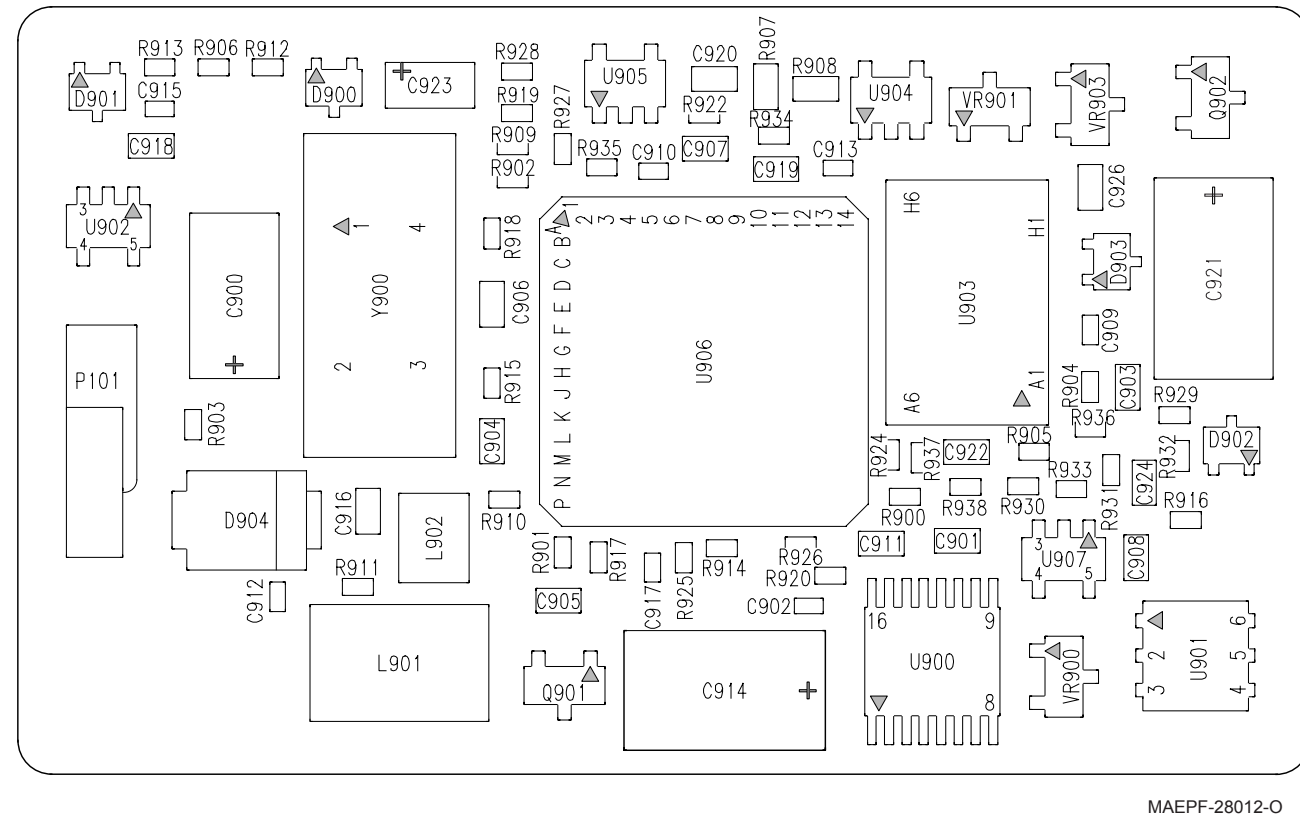
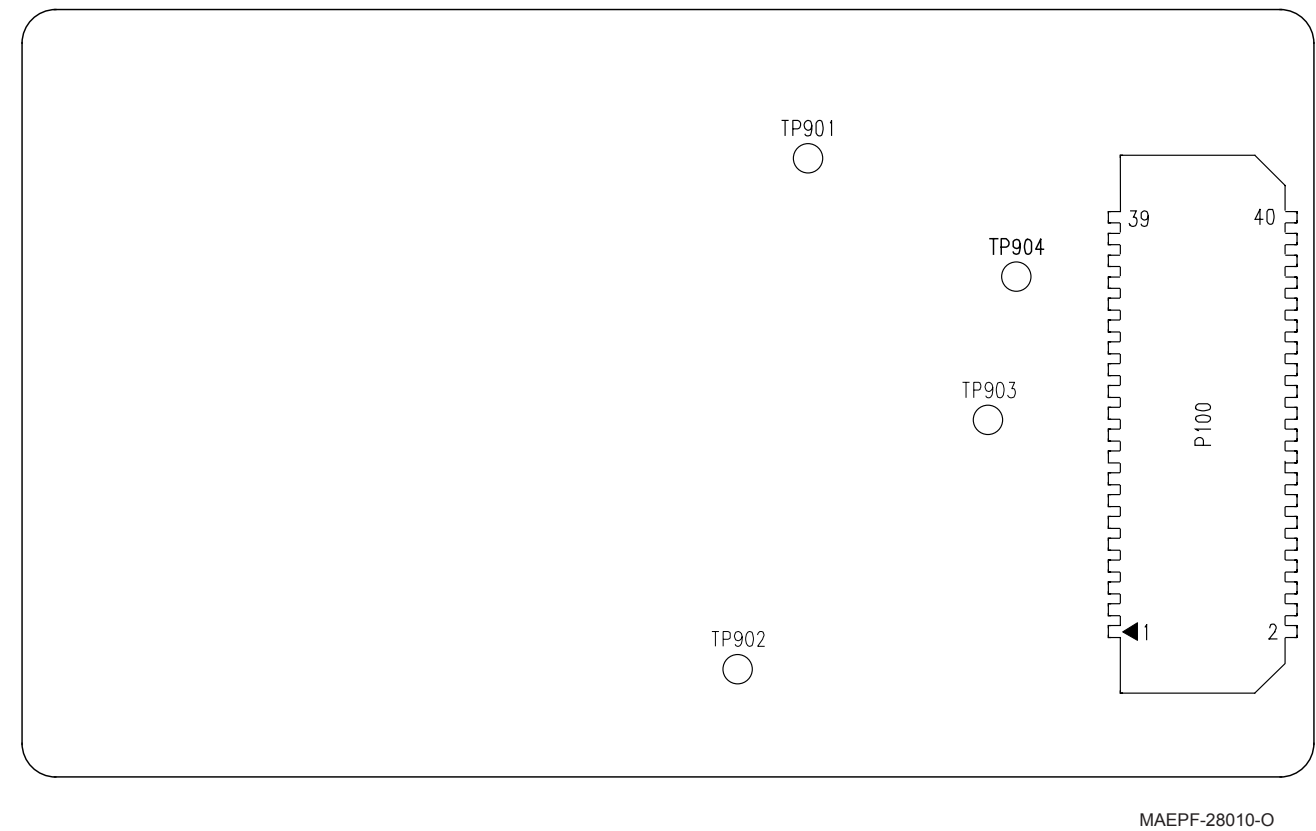


Figure 12-31. UCM Board Layout—Side 2



Appendix A Accessories

Motorola provides the following approved optional accessories to improve the productivity of the SSE 5000 portable radio.

A.1 Antennas

NAE6132	UHF (for PSM NMN6129)
NAE6440	UHF whip

A.2 Batteries

HNN9033*	impres™ NiCd (2000 mAh)
HNN9034*	impres™ NiCd FM (2000 mAh)
HNN9034_SP01*	impres™ NiCd FM (2000 mAh), engraved (NYPD)
NTN4595	Premium NiCd (1800 mAh, 7.5 V)
NTN4596	Premium NiCd FM (1800 mAh, 7.5 V)
NTN4992	Premium NiCd FM (1800 mAh, 7.5 V) (HazMat)
NTN4992_SP01	Premium NiCd FM (1800 mAh, 7.5 V) (HazMat), engraved (NYPD)

* B versions of batteries or higher only

A.3 Carrying Accessories

4205633T01	Belt loop (used with carry case NTN5644_SP01)
NNTN4709	Belt clip
NTN5574_SP02	T-strap (6 in.) with hard snap and dual fasteners (used with carry case NTN5644_SP01)
NTN5644_SP01	Carry case, leather

A.4 Chargers and Charger Accessories

NLN7697	Wall mount kit
RLN5382	Individual retrofit charger display module (CDM)
WPLN4108	impres™ 6-bay multi-unit, 110 V
WPLN4111	impres™ single-unit, 110 V
WPLN4130	impres™ 6-bay multi-unit, 110 V, with display

A.5 Dust Cover

NTN7061	Dust cover for universal accessory connector
---------	--

A.6 Keyload Accessories

TKN8506	KVL 3000 keyloader cable
---------	--------------------------

A.7 Microphones and Microphone Accessories

NMN6129	Public Safety Mic (PSM)
NMN6158	Back swivel PSM clip
NMN6225	Remote speaker mic (RSM)

A.8 Programming Cables

RKN4121	USB cable
RKN4122	RS232 cable

A.9 Surveillance Accessories

NTN5664	Surveillance kit/keyloader adapter
ZMN6032	Surveillance kit (mic and PTT), 2-wire
ZMN6038	Surveillance kit (mic and PTT), 2-wire (extra loud)

Appendix B Replacement Parts Ordering

B.1 Basic Ordering Information

When ordering replacement parts or equipment information, the complete identification number should be included. This applies to all components, kits, and chassis. If the component part number is not known, the order should include the number of the chassis or kit of which it is a part, and sufficient description of the desired component to identify it.

Crystal orders should specify the crystal type number, crystal and carrier frequency, and the model number in which the part is used.

B.2 Transceiver Board and VOCON Board Ordering Information

When ordering a replacement transceiver board or VOCON board, refer to the applicable model chart in the front of this manual, read the transceiver board or VOCON board note, and include the proper information with your order.

B.3 Motorola Online

Motorola Online users can access our online catalog at

<https://www.motorola.com/businessonline>

To register for online access:

- Domestic customers: please call 800-814-0601 (U.S. and Canada).
- International customers: please go to <https://www.motorola.com/businessonline> and click on "Sign Up Now."

B.4 Mail Orders

Send written orders to the following addresses:

**United States and Canada Orders
(except for U.S. Federal
Government orders):**

Motorola Inc.
Radio Products and
Services Division*
Attention: Order Processing
2200 Galvin Drive
Elgin, IL 60123
U.S.A.

U.S. Federal Government Orders:

Motorola Inc.
U.S. Federal Government
Markets Division
Attention: Order Processing
7230 Parkway Drive
Landover, MD 21076
U.S.A.

International Orders:

Motorola Inc.
Radio Products and
Services Division*
Attention: International
Order Processing
2200 Galvin Drive
Elgin, IL 60123
U.S.A.

B.5 Telephone Orders

Radio Products and Services Division*
(United States and Canada)
7:00 AM to 7:00 PM (Central Standard Time)
Monday through Friday (Chicago, U.S.A.)
1-800-422-4210
1-847-538-8023 (International Orders)

U.S. Federal Government Markets Division (USFGMD)
1-800-826-1913 Federal Government Parts - Credit Cards Only
8:30 AM to 5:00 PM (Eastern Standard Time)

B.6 Fax Orders

Radio Products and Services Division*
(United States and Canada)
1-800-622-6210
1-847-576-3023 (International)

USFGMD
(Federal Government Orders)
1-800-526-8641 (For Parts and Equipment Purchase Orders)

B.7 Parts Identification

Radio Products and Services Division*
(United States and Canada)
1-800-422-4210, menu 3

B.8 Product Customer Service

Customer Response Center
(Non-technical Issues)
1-800-247-2346
FAX:1-800-247-2347

*The Radio Products and Services Division (RPSD) was formerly known as the Customer Care and Services Division (CCSD) and/or the Accessories and Aftermarket Division (AAD).

Glossary

This glossary contains an alphabetical listing of terms and their definitions that are applicable to portable and mobile subscriber radio products.

Term	Definition
A/D	<i>See analog-to-digital conversion.</i>
Abacus IC	A custom integrated circuit providing a digital receiver intermediate frequency (IF) backend.
ADC	<i>See analog-to-digital converter.</i>
ALC	<i>See automatic level control.</i>
analog	Refers to a continuously variable signal or a circuit or device designed to handle such signals. <i>See also digital.</i>
analog-to-digital conversion	Conversion of an instantaneous dc voltage level to a corresponding digital value. <i>See also D/A.</i>
analog-to-digital converter	A device that converts analog signals into digital data. <i>See also DAC.</i>
antenna	Any structure or device used to collect or radiate electromagnetic waves.
automatic level control	A circuit in the transmit RF path that controls RF power amplifier output, provides leveling over frequency and voltage, and protects against high VSWR.
band	Frequencies allowed for a specific purpose.
BBP	<i>See baseband interface port.</i>
baseband interface port	Synchronous serial interface to the transceiver board used to transfer transmit and receive audio data.
BGA	<i>See ball grid array.</i>
ball grid array	A type of IC package characterized by solder balls arranged in a grid that are located on the underside of the package.
clear to send	A handshaking signal (used in communication links, especially RS232) used by a transmitter to indicate to a receiver that transmission may proceed. Generated in response to a request-to-send signal. <i>See also request to send.</i>
CODEC	<i>See coder/decoder.</i>

Term	Definition
codeplug	Firmware that contains the unique personality for a system or device. A codeplug is programmable and allows changes to system and unit parameters. <i>See also firmware.</i>
coder/decoder	A device that encodes or decodes a signal.
CPS	<i>See Customer Programming Software.</i>
CTS	<i>See clear to send.</i>
Customer Programming Software	Software with a graphical user interface containing the feature set of a radio. <i>See also RSS.</i>
D/A	<i>See digital-to-analog conversion.</i>
DAC	<i>See digital-to-analog converter.</i>
debounce time	An amount of time (which is set using a hardware device or software) that ensures that only a single signal will be acted upon for a single opening or closing of a contact.
deemphasis	In an FM transmission, the process of restoring the amplitude-versus-frequency characteristics of the signal.
default	A pre-defined set of parameters.
deviation	The difference, usually the absolute difference, between a number and the mean of a set of numbers, or between a forecast value and the actual value.
digital	Refers to data that is stored or transmitted as a sequence of discrete symbols from a finite set; most commonly this means binary data represented using electronic or electromagnetic signals. <i>See also analog.</i>
digital-to-analog conversion	Conversion of a digital signal to a voltage that is proportional to the input value. <i>See also A/D.</i>
digital-to-analog converter	A device that converts digital data into analog signals. <i>See also ADC.</i>
digital signal processor	A microcontroller specifically designed for performing the mathematics involved in manipulating analog information, such as sound, that has been converted into a digital form. DSP also implies the use of a data compression technique.
digital signal processor code	Object code executed by the Digital Signal Processor in a subscriber radio. The DSP is responsible for computation-intensive tasks, such as decoding ASTRO signaling.
DSP	<i>See digital signal processor.</i>
DSP code	<i>See digital signal processor code.</i>

Term	Definition
DTMF	<i>See dual tone multi-frequency.</i>
dual tone multi-frequency	The system used by touch-tone telephones. DTMF assigns a specific frequency, or tone, to each key so that it can easily be identified by a microprocessor.
EEPROM	<i>See Electrically Erasable Programmable Read-Only Memory.</i>
effective radiated power	The power supplied to an antenna multiplied by the antenna gain in a given direction. ERP is usually calculated by multiplying the measured transmitter output power by the specified antenna system gain, relative to a half-wave dipole, in the direction of interest.
EIA	Electronic Industries Association
Electrically Erasable Programmable Read-Only Memory	A special type of PROM that can be erased by exposing it to an electrical charge. An EEPROM retains its contents even when the power is turned off.
electronic potentiometer	A digital potentiometer that is electrically programmable.
EPOT	<i>See electronic potentiometer.</i>
ERP	<i>See effective radiated power.</i>
FCC	Federal Communications Commission.
firmware	Code executed by an embedded processor such as the Host or DSP in a subscriber radio. This type of code is typically resident in non-volatile memory and as such is more difficult to change than code executed from RAM.
FGU	<i>See frequency generation unit.</i>
flash	A non-volatile memory device similar to an EEPROM. Flash memory can be erased and reprogrammed in blocks instead of one byte at a time.
FLASHcode	A 13-digit code which uniquely identifies the System Software Package and Software Revenue Options that are enabled in a particular subscriber radio. FLASHcodes are only applicable for radios which are upgradeable through the FLASHport process.
FLASHport	A Motorola term that describes the ability of a radio to change memory. Every FLASHport radio contains a FLASHport memory chip that can be software written and rewritten to, again and again.
FMR	<i>See Florida Manual Revision.</i>
Florida Manual Revision	A publication that provides supplemental information for its parent publication before it is revised and reissued.

Term	Definition
frequency	Number of times a complete electromagnetic-wave cycle occurs in a fixed unit of time (usually one second).
frequency generation unit	This unit generates ultra-stable, low-phase noise master clock and other derived synchronization clocks that are distributed throughout the communication network.
General-Purpose Input/Output	Pins whose function is programmable.
GPIO	<i>See General-Purpose Input/Output.</i>
ground	In an electrical circuit, a common return path that (a) may not necessarily be connected to earth and (b) is the zero-voltage reference level for the equipment or system.
ground plane	An electrically conductive surface that serves as the near-field reflection point for an antenna.
host code	Object code executed by the host processor in a subscriber radio. The host is responsible for control-oriented tasks such as decoding and responding to user inputs.
IC	<i>See integrated circuit.</i>
IF	Intermediate Frequency.
impedance	The total opposition, including both resistance and reactance, that a circuit offers to the flow of alternating current (AC) or any other varying current at a particular frequency.
inbound signaling word	Data transmitted on the control channel from a subscriber unit to the central control unit.
integrated circuit	An assembly of interconnected components on a small semiconductor chip, usually made of silicon. One chip can contain millions of microscopic components and perform many functions.
ISW	<i>See inbound signaling word.</i>
key-variable loader	A device used to load encryption keys into a radio.
kHz	<i>See kilohertz.</i>
kilohertz	One thousand cycles per second. Used especially as a radio-frequency unit.
KVL	<i>See key-variable loader.</i>
LCD	<i>See liquid-crystal display.</i>
LED	<i>See LED.</i>
light emitting diode	An electronic device that lights up when electricity is passed through it.

Term	Definition
liquid-crystal display	An LCD uses two sheets of polarizing material with a liquid-crystal solution between them. An electric current passed through the liquid causes the crystals to align so that light cannot pass through them.
LO	<i>See local oscillator.</i>
local oscillator	A device used to generate a signal that is combined with another signal in order to mix the second signal to a different frequency.
low-speed handshake	150-baud digital data sent to the radio during trunked operation while receiving audio.
LSH	<i>See low-speed handshake.</i>
Master In Slave Out	SPI data line from a peripheral to the MCU.
Master Out Slave In	SPI data line from the MCU to a peripheral.
MCU	<i>See microcontroller unit.</i>
MDC	Motorola Digital Communications.
MHz	<i>See Megahertz.</i>
Megahertz	One million cycles per second. Used especially as a radio-frequency unit.
microcontroller unit	Also written as μC . A microprocessor that contains RAM and ROM components, as well as communications and programming components and peripherals.
MISO	<i>See Master In Slave Out.</i>
MOSFET	Metal-Oxide-Silicon Field Effect Transistor
MOSI	<i>See Master Out Slave In.</i>
multiplexer	An electronic device that combines several signals for transmission on some shared medium (e.g., a telephone wire).
MUX	<i>See multiplexer.</i>
NiCd	Nickel-cadmium.
NiMH	Nickel-metal-hydride.
ohm	A unit of electrical resistance.
OMPAC	<i>See over-molded pad-array carrier.</i>
open architecture	A controller configuration that utilizes a microprocessor with extended ROM, RAM, and EEPROM.
oscillator	An electronic device that produces alternating electric current and commonly employs tuned circuits and amplifying components.

Term	Definition
OSW	<i>See outbound signaling word.</i>
OTAR	<i>See over-the-air rekeying.</i>
outbound signaling word	Data transmitted on the control channel from the central controller to the subscriber unit.
over-molded pad-array carrier	A Motorola custom IC package, distinguished by the presence of solder balls on the bottom pads.
over-the-air rekeying	Allows the dispatcher to remotely reprogram the encryption keys in the radio.
PA	Power amplifier.
paging	One-way communication that alerts the receiver to retrieve a message.
PC Board	Printed Circuit Board. Also referred to as a PCB.
phase-locked loop	A circuit in which an oscillator is kept in phase with a reference, usually after passing through a frequency divider.
pigtail	A short length of electrical conductor permanently affixed to a component, used to connect the component to another conductor.
pinout	A description of the purpose of each pin in a multi-pin hardware connection interface.
PL	<i>See private-line tone squelch.</i>
PLL	<i>See phase-locked loop.</i>
polarity	The positive or negative state in which a body reacts to a magnetic, electric, or other field.
private-line tone squelch	A continuous sub-audible tone that is transmitted along with the carrier.
Programmable Read-Only Memory	A memory chip on which data can be written only once. Once data has been written onto a PROM, it remains there forever.
PROM	<i>See Programmable Read-Only Memory.</i>
PTT	<i>See Push-to-Talk.</i>
Push-to-Talk	The switch or button usually located on the left side of the radio which, when pressed, causes the radio to transmit. When the PTT is released, the unit returns to receive operation.
radio frequency	The portion of the electromagnetic spectrum between audio sound and infrared light (approximately 10 kHz to 10 GHz).
radio frequency power amplifier	Amplifier having one or more active devices to amplify radio signals.

Term	Definition
Radio Service Software	DOS-based software containing the feature set of a radio. <i>See also CPS.</i>
random access memory	A type of computer memory that can be accessed randomly; that is, any byte of memory can be accessed without touching the preceding bytes.
RAM	<i>See random access memory.</i>
read-only memory	A type of computer memory on which data has been prerecorded. Once data has been written onto a ROM chip, it cannot be removed and can only be read.
receiver	Electronic device that amplifies RF signals. A receiver separates the audio signal from the RF carrier, amplifies it, and converts it back to the original sound waves.
registers	Short-term data-storage circuits within the microcontroller unit or programmable logic IC.
repeater	Remote transmit/receive facility that re-transmits received signals in order to improve communications range and coverage (conventional operation).
repeater/talkaround	A conventional radio feature that permits communication through a receive/transmit facility, which re-transmits received signals in order to improve communication range and coverage.
request to send	A handshaking signal (used in communication links, especially RS232) to indicate that data is ready for transmission. <i>See also clear to send.</i>
RESET	Reset line: an input to the microcontroller that restarts execution.
RF	<i>See radio frequency.</i>
RF PA	<i>See radio frequency power amplifier.</i>
ROM	<i>See read-only memory.</i>
RPCIC	Regulator/power control IC.
RPT/TA	<i>See repeater/talkaround.</i>
RS232	A common interface standard for data communication equipment.
RSS	<i>See Radio Service Software.</i>
RTS	<i>See request to send.</i>
RX	Receive.
RX DATA	Recovered digital data line.
SAP	<i>See Serial Audio CODEC Port.</i>

Term	Definition
Serial Audio CODEC Port	SSI to and from the GCAP II IC CODEC used to transfer transmit and receive audio data.
Serial Peripheral Interface	How the microcontroller communicates to modules and ICs through the CLOCK and DATA lines.
serial port	A hardware interface on a radio that transmits data one bit at a time.
sideband	The band of frequencies on either side of the carrier frequency, produced by modulation of a carrier wave.
signal	An electrically transmitted electromagnetic wave.
Signal Qualifier mode	An operating mode in which the radio is muted, but still continues to analyze receive data to determine RX signal type.
softpot	<i>See software potentiometer.</i>
software	Computer programs, procedures, rules, documentation, and data pertaining to the operation of a system.
software potentiometer	A computer-adjustable electronic attenuator.
spectrum	Frequency range within which radiation has specific characteristics.
SPI	<i>See Serial Peripheral Interface.</i>
squelch	Muting of audio circuits when received signal levels fall below a pre-determined value. With carrier squelch, all channel activity that exceeds the radio's preset squelch level can be heard.
SRAM	<i>See static RAM.</i>
SSI	<i>See Synchronous Serial Interface.</i>
Standby mode	An operating mode in which the radio is muted but still continues to monitor data.
static RAM	A type of memory used for volatile, program/data memory that does not need to be refreshed.
station	One or more transmitters or receivers, including the accessory equipment, necessary at one location for carrying on radio communication services.
Synchronous Serial Interface	DSP interface to peripherals that consists of a clock signal line, a frame synchronization signal line, and a data line.
system central controllers	Main control unit of the trunked dispatch system; handles ISW and OSW messages to and from subscriber units (<i>See ISW and OSW</i>).
system select	The act of selecting the desired operating system with the system-select switch (also, the name given to this switch).

Term	Definition
termination	An impedance, often resistive, that is connected to a radio as a dummy load, for test purposes.
thin small-outline package	A type of dynamic random-access memory (DRAM) package that is commonly used in memory applications.
time-out timer	A timer that limits the length of a transmission.
TOT	<i>See time-out timer.</i>
transceiver	Transmitter-receiver. A device that both transmits and receives analog or digital signals. Also abbreviated as XCVR.
transmitter	Electronic equipment that generates and amplifies an RF carrier signal, modulates the signal, and then radiates it into space.
TSOP	<i>See thin small-outline package.</i>
TX	Transmit.
UART	<i>See also Universal Asynchronous Receiver Transmitter.</i>
UHF	Ultra-High Frequency.
Universal Asynchronous Receiver Transmitter	A microchip with programming that controls a computer's interface to its attached serial devices.
Universal Serial Bus	An external bus standard that supports data transfer rates of 12 Mbps.
USB	<i>See Universal Serial Bus.</i>
VCO	<i>See voltage-controlled oscillator.</i>
VHF	Very-High Frequency.
VOCON	<i>See vocoder/controller.</i>
vocoder	An electronic device for synthesizing speech by implementing a compression algorithm particular to voice. <i>See also voice encoder.</i>
vocoder/controller	A PC board that contains a radio's microcontroller, DSP, memory, audio and power functions, and interface support circuitry.
voice encoder	The DSP-based system for digitally processing analog signals, and includes the capabilities of performing voice compression algorithms or voice encoding. <i>See also vocoder.</i>
voltage	The electric pressure between two points, which is capable of producing current flow when there is a closed circuit between the two points.
voltage-controlled oscillator	An oscillator in which the frequency of oscillation can be varied by changing a control voltage.
XCVR	<i>See transceiver.</i>

Notes

Index

A

accessories
 antennas A-1
 batteries A-1
 carry A-1
 chargers A-1
 dust cover A-1
 keyload A-2
 microphone accessories A-2
 microphones A-2
 programming cables A-2
 surveillance A-2
 alignment, tuner
 introduction 5-1
 main menu 5-2
 radio information screen 5-2
 reference oscillator 5-3
 softpot use 5-3
 test setup 5-1
 transmit deviation balance 5-7
 transmit deviation limit 5-8
 transmit power 5-4
 transmitter test pattern 5-9
 analog mode
 receiving 2-2
 transmitting 2-3
 antenna
 attaching 7-6
 removing 7-6
 antennas, types A-1
 audio and power supply IC theory of operation 2-24
 audio power amplifier theory of operation 2-24

B

battery
 attaching 7-7
 removing 7-7
 types A-1
 types and capacities 2-4
 belt clip
 attaching 7-7
 removing 7-8
 block diagram
 power distribution 2-4
 board overlays
 transceiver (RF) board 12-10

C

carry case
 assembly 7-9
 channel select knob
 installing 7-11
 removing 7-11
 charts, troubleshooting
 button test 9-13
 channel/zone select error 9-12

DC supply failure 9-5
 display failure 9-8
 keyload failure 9-28
 list 9-1
 main 9-2
 power-up failure 9-3
 secure hardware failure 9-29
 top/side button test 9-14
 VCO Tx/Rx unlock 9-15
 VOCON
 Rx audio 9-18
 Rx RF 9-20
 Tx audio 9-16
 Tx RF 9-25
 volume set error 9-11
 chassis and housing assemblies
 joining 7-16
 separating 7-12
 chassis assembly
 disassembling 7-12
 reassembling 7-16
 cleaning external plastic surfaces 7-1
 control top
 disassembling 7-13
 reassembling 7-15
 control top and keypad test mode 4-5

D

digital signal processor (DSP) theory of operation 2-21
 digital support IC theory of operation 2-26
 disassembly/reassembly
 antenna
 attaching 7-6
 removing 7-6
 battery
 attaching 7-7
 removing 7-7
 belt clip
 attaching 7-7
 removing 7-8
 carry case 7-9
 channel select knob
 installing 7-11
 removing 7-11
 chassis assembly
 disassembling 7-12
 reassembling 7-16
 control top
 disassembling 7-13
 reassembling 7-15
 introduction 7-1
 universal connector dust cover
 attaching 7-10
 removing 7-10
 volume knob 7-11
 installing 7-12
 removing 7-11

E

encryption
 troubleshooting chart 8-4

error codes
 operational 8-3
 power-up 8-2
 exploded view 7-3

F

field programming equipment 3-6
 FLASHport 1-1
 frequency generation unit theory of operation 2-16

G

GCAP II IC U501
 power routing 2-5
 global control audio and power II IC 501 *See GCAP II IC U501*

H

handling precautions 7-2

K

key, encryption
 loading 6-1
 knob
 channel select
 installing 7-11
 removing 7-11
 volume
 installing 7-12
 removing 7-11

L

loading an encryption key 6-1

M

maintenance
 cleaning 7-1
 inspection 7-1
 manual
 notations 1-5
 MCU theory of operation 2-20
 model chart
 numbering system 1-2
 model numbering system, radio 1-2

N

notations
 manual 1-5
 warning, caution, and danger 1-5

O

ordering replacement parts B-1

P

parts, ordering replacement B-1
 performance checks
 receiver 4-6
 test setup 4-1
 transmitter 4-7
 power distribution
 block diagram 2-4
 radio 2-4
 transceiver board 2-5
 VOCON board 2-5
 power-up error codes 8-2
 precautions, handling 7-2

R

radio
 alignment 5-1
 control top and keypad test mode 4-5
 disassembling
 chassis assembly 7-12
 control top 7-13
 separating chassis and housing assemblies 7-12
 entering test mode 4-2
 exploded view 7-3
 FLASHport feature 1-1
 information screen 5-2
 model numbering system 1-2
 physical features 1-1
 power distribution 2-4
 reassembling
 chassis assembly 7-16
 control top 7-15
 joining chassis and housing assemblies 7-16
 RF test mode 4-4
 test environments 4-4
 test frequencies 4-4
 test mode 4-2
 test environments 4-4
 test frequencies 4-4
 receiver
 performance checks 4-6
 troubleshooting 8-3
 receiver back-end theory of operation 2-10
 receiver front-end theory of operation 2-9
 receiving
 analog mode 2-2
 reference oscillator alignment 5-3
 replacement parts, ordering B-1
 RF test mode
 radio 4-4

S

schematics
 transceiver (RF) board 12-2
 service aids 3-3
 signal tracing, troubleshooting 8-1
 softpot 5-3
 specifications
 UHF radios 1-4
 standard supply voltages 8-1

surveillance accessories
 earpieces A-2
 system clocks
 troubleshooting 8-1

T

test equipment
 recommended 3-1
 test mode, entering
 radios 4-2
 test setup
 alignment 5-1
 performance checks 4-1
 tests
 receiver
 performance checks 4-6
 transmitter
 performance checks 4-7
 theory of operation
 first IF frequencies 2-9
 frequency generation unit 2-16
 local oscillator frequencies 2-9
 major assemblies 2-1
 mode 2-2
 overview 2-1
 receiver back-end 2-10
 receiver front-end 2-9
 transceiver (XCVR) board 2-7
 VOCON board
 audio and power supply IC 2-24
 audio power amplifier 2-24
 components 2-17
 digital support IC 2-26
 DSP 2-21
 MCU 2-20
 transceiver
 board overlays 12-10
 power distribution diagram 2-5
 schematics 12-2
 voltage regulators 2-5
 transceiver board theory of operation 2-7
 transmit deviation
 balance alignment 5-7
 limit alignment 5-8
 transmit power alignment 5-4
 transmitter
 performance checks 4-7
 test pattern 5-9
 troubleshooting 8-4
 transmitting
 analog mode 2-3
 troubleshooting
 button test 9-13
 channel/zone select error 9-12
 charts listing 9-1
 DC supply failure 9-5
 display failure 9-8
 encryption problems 8-4
 introduction 8-1
 keyload failure 9-28
 main chart 9-2
 operational error codes 8-3
 power-up error codes 8-2

power-up failure 9-3
 receiver problem chart 8-3
 secure hardware failure 9-29
 signal tracing 8-1
 standard supply voltages 8-1
 system clocks 8-1
 top/side button test 9-14
 transmitter problem chart 8-4
 VCO Tx/Rx unlock 9-15
 VOCON
 Rx audio 9-18
 Rx RF 9-20
 Tx audio 9-16
 Tx RF 9-25
 voltage measurement 8-1
 volume set error 9-11
 troubleshooting waveforms
 13 MHz clock 11-2
 16.8 MHz buffer input and output 11-3
 32.768 kHz clock outputs 11-4
 list 11-1
 receive baseband interface port (BBP) 11-7
 RX serial audio port (SAP) 11-6
 SPI B data 11-5
 transmit baseband interface port (BBP) 11-8
 tuner
 introduction 5-1
 main menu 5-2
 radio information screen 5-2
 reference oscillator alignment 5-3
 test setup 5-1
 transmit deviation balance alignment 5-7
 transmit deviation limit alignment 5-8
 transmit power alignment 5-4
 transmitter test pattern 5-9

U

universal connector dust cover
 attaching 7-10
 removing 7-10

V

view, exploded 7-3
 VOCON board
 audio and power supply IC theory of operation 2-24
 audio power amplifier theory of operation 2-24
 digital support IC theory of operation 2-26
 DSP theory of operation 2-21
 MCU theory of operation 2-20
 power distribution 2-5
 theory of operation 2-17
 voltage
 measurement, troubleshooting 8-1
 regulators, transceiver 2-5
 voltages, standard supply 8-1
 volume knob
 installing 7-12
 removing 7-11

W

- warning, caution, and danger notations 1-5
- warranty, commercial xi
- waveforms, troubleshooting
 - 13 MHz clock 11-2
 - 16.8 MHz buffer input and output 11-3
 - 32.768 kHz clock outputs 11-4
 - list 11-1
 - receive baseband interface port (BBP) 11-7
 - RX serial audio port (SAP) 11-6
 - SPI B data 11-5
 - transmit baseband interface port (BBP) 11-8



Motorola, Inc.
8000 West Sunrise Boulevard
Ft. Lauderdale, FL 33322

MOTOROLA, the Stylized M logo, and FLASHport
are registered in the US Patent & Trademark Office.
All other product or service names are the property of their
respective owners. © Motorola, Inc. 2005.
All rights reserved. Printed in U.S.A.



6881094C12-A

Free Manuals Download Website

<http://myh66.com>

<http://usermanuals.us>

<http://www.somanuals.com>

<http://www.4manuals.cc>

<http://www.manual-lib.com>

<http://www.404manual.com>

<http://www.luxmanual.com>

<http://aubethermostatmanual.com>

Golf course search by state

<http://golfingnear.com>

Email search by domain

<http://emailbydomain.com>

Auto manuals search

<http://auto.somanuals.com>

TV manuals search

<http://tv.somanuals.com>