

SG4-DRT-2X

Installation Sheet 509978-001

The Motorola® Digital Return Transmitter (SG4-DRT-2X) implements Time Division Multiplexing (TDM) to convert two, independent 5 to 65 MHz analog RF return-path signals, into one digital optical signal within SG4000 optical nodes. This digital optical signal with 10-bit resolution and 3.125 Gbps rate is suitable for optical transmission on the International Telecommunications Union (ITU) grid to the GX2-DRR-2X Digital Return Receiver (DRR) where the original analog return-path signals are recreated.

The transmitter is configured with an 8 dBm digital Distributed Feedback (DFBT) laser that is thermally stabilized to minimize wavelength drift. Multiple ITU wavelengths are available depending on specific link requirements. The specific ITU channel and frequency are stamped on the label on each transmitter and are identified in the subsection SG4-DRT-2X Models at the end of this document.

The SG4-DRT-2X transmitter features high-speed digital technology to achieve reliable return path communications at greater distances. The system is completely scalable and can be expanded from a single transmitter/receiver to groups of 4, 8, 16, 32, or 40 wavelengths over a single fiber with the use of muxing and demuxing equipment. The system is compatible with Motorola low-noise optical amplifiers (EDFAs), enabling network designs that cover large geographical areas. Without amplification, the SG4-DRT-2X Dense Wave Division Multiplexing (DWDM) digital return system is capable of achieving a link loss budget of 26 dB.

The system achieves superior noise power ratio (NPR) and dynamic range (DR) performance in return path communications. The SG4-DRT-2X system is HMS compliant and features an enable/fault LED to report local status information. The SG4-DRT-2X comes standard with SC/APC optical connectors; E2000 adapters are optional.

To facilitate easy upgrades, the double-wide SG4-DRT-2X module has the same set-up levels as the analog return transmitters and can accomplish any two-transmitter configuration using only a single fiber.

Figure 1 illustrates a block diagram of the SG4-DRT-2X:

Figure 1
SG4-DRT-2X block diagram

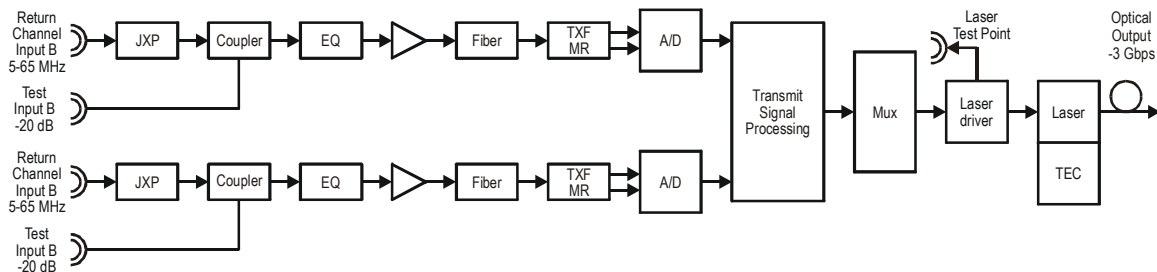

Figure 2 illustrates the SG4-DRT-2X with the cover on (left) and cover off (right):

Figure 2
SG4-DRT-2X transmitter

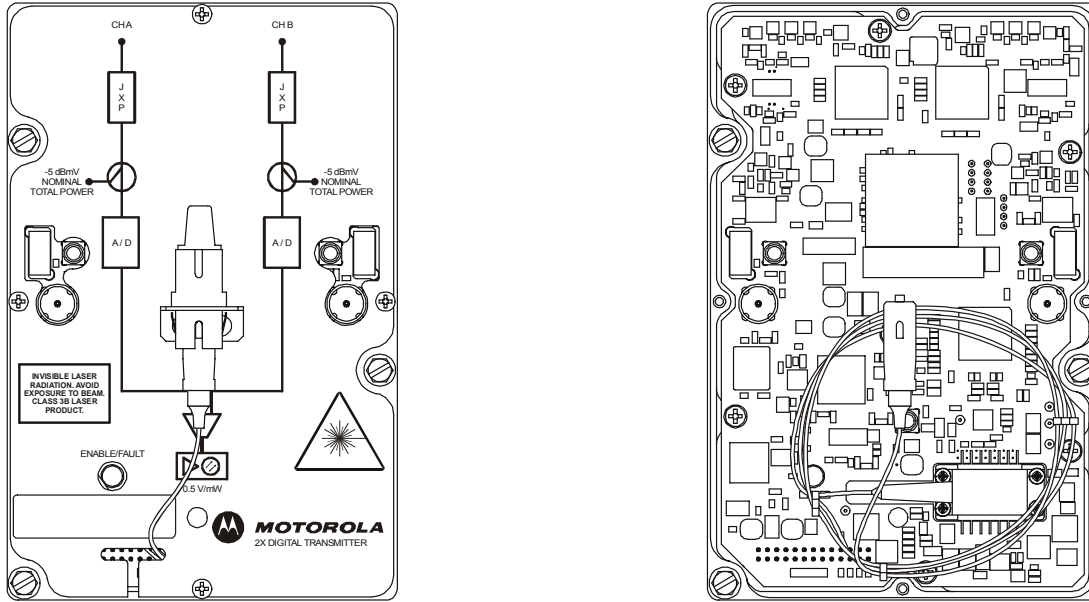

Figure 3 illustrates the user-interface features of the SG4-DRT-2X:

Figure 3
User features

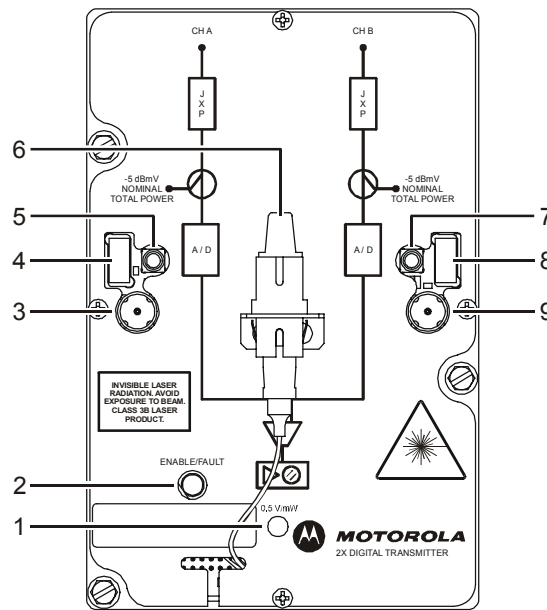

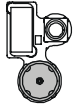
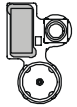

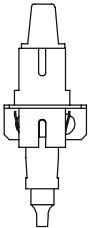

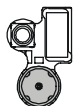

Table 1 identifies and provides information on the user-interface features of the SG4-DRT-2X:

Key	Feature	Description
1		This test point enables monitoring of the optical output level of the module. The nominal scale factor is 0.5 V/mW. Note that the optical power test point does not track changes in optical power due to the laser tracking error.
2		A red LED (FAULT) indicates that the laser output power is below normal limits. Because the laser output requires a short period of time to stabilize, it is normal for the LED not to illuminate for approximately 10 seconds. Note that the module must be enabled for the fault indicator to function. A green LED (ENABLE) provides visual indication of the transmitter's enable status.
3		CH A RF input test point (–5 dBmV nominal total power)
4		CH A JXP attenuator location. Used to adjust –5 dBmV nominal total power reading at CH A test point.
5		This MCX connector provides the SG4-DRT-2X with CH A RF input through a cable connection from the configuration board in an SG4000.
6		Optical bulkhead with SC/APC type connector that provides output from the SG4-DRT-2X
7		This MCX connector provides the SG4-DRT-2X with CH B RF input through a cable connection from the configuration board in an SG4000.
8		CH B JXP attenuator location. Used to adjust –5 dBmV nominal total power reading at CH B test point.
9		CH B RF input test point (–5 dBmV nominal total power)

Installing the SG4-DRT-2X in the SG4000 Node

The SG4000 carries each RF return path individually to the lid configuration boards and typically no adjustments to the RF modules in the housing base are necessary.

Before you install the SG4-DRT-2X in the SG4000, ensure that you have the return configuration boards for the specific application. Simply stated, the SG4-DRT behaves as two analog transmitters. A single SG4-DRT-2X transmitter supports the split return configuration. (Note: A single SG-DRT-2X also accommodates combined and combined redundant configurations, but these applications are not covered in this Installation Sheet). You may place a single transmitter in optics slots 3 and 4 *or* 5 and 6 in the SG4000 lid. Dual SG4-DRT-2X transmitters support split return redundant and segmented configurations. The dual transmitters occupy slots 3 and 4 *and* 5 and 6 in the SG4000 lid.

The SG4-DRT-2X transmitter design enables you to install it while the node is in service. The module's flat bottom provides an excellent thermal transfer surface and has locating holes that align with guide pins in the lid of the node.

To install the SG4-DRT-2X:

- 1 If present, remove any analog transmitter that occupies lid optics slots 3 and 4, and/or 5 and 6 in the SG4000 lid as illustrated in Figure 3, and then install the double-wide SG4-DRT-2X:

Figure 4
SG4000 lid with two analog transmitters

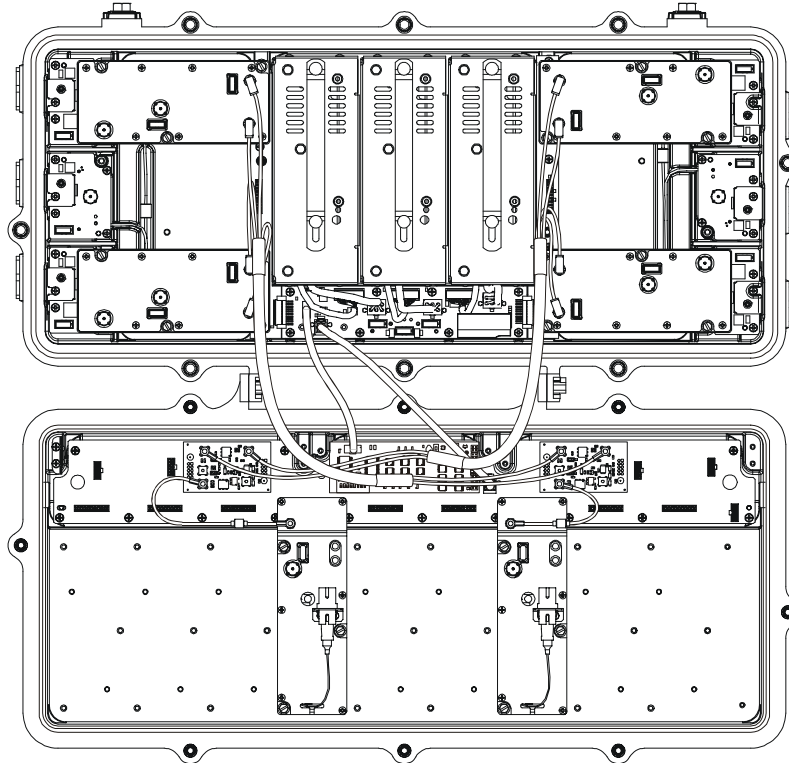

- 2 Position the SG2-DRT-2X module in the appropriate slot and press gently on the casting until it is fully seated.

- 3 Tighten the three 1/4 inch mounting bolts to 8 – 12 in/lbs to secure the module in the SG4000 lid.
- 4 Repeat as required for a second SG4-DRT-2X.

Figure 5 illustrates a properly installed and cabled SG4-DRT-2X:

Figure 5
SG4-DRT-2X installed in SG4000

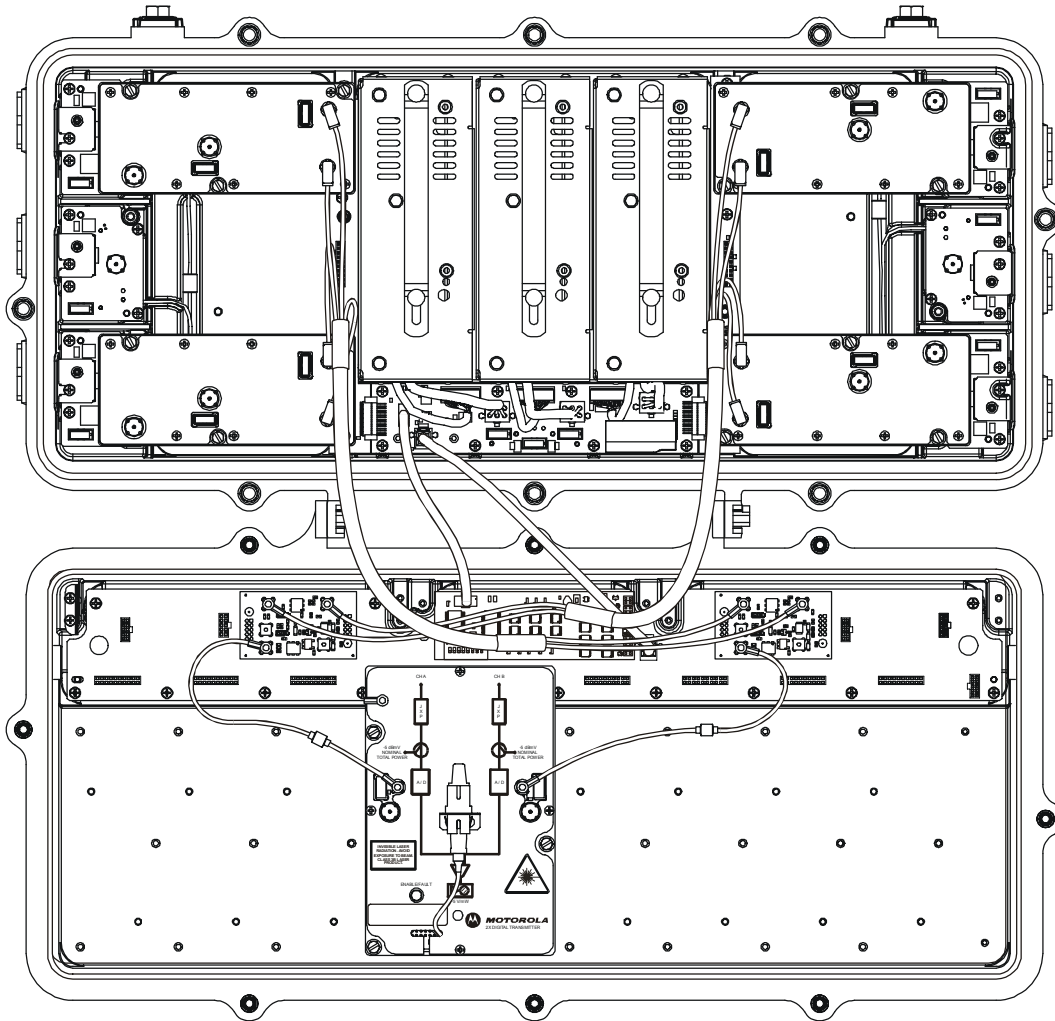

Split Return

In the split return configuration, each pair of RF returns is applied to a separate 2X redundant return configuration board. In a typical installation, the RF modules in Ports 1 and 3 are connected to the 2X redundant return board in return configuration location 2. The RF modules in Ports 4 and 6 are connected to the 2X redundant return configuration board in configuration location 3. The 2X redundant return configuration board, in location 2, directs RF to CH B of the SG4-DRT-2X. The 2X redundant return configuration board, in location 3, directs RF to CH A of the SG4-DRT-2X. The same configuration board is used in the split redundant return configuration explained in the next subsection.

Figure 6 illustrates the split return configuration:

Figure 6
Split return configuration

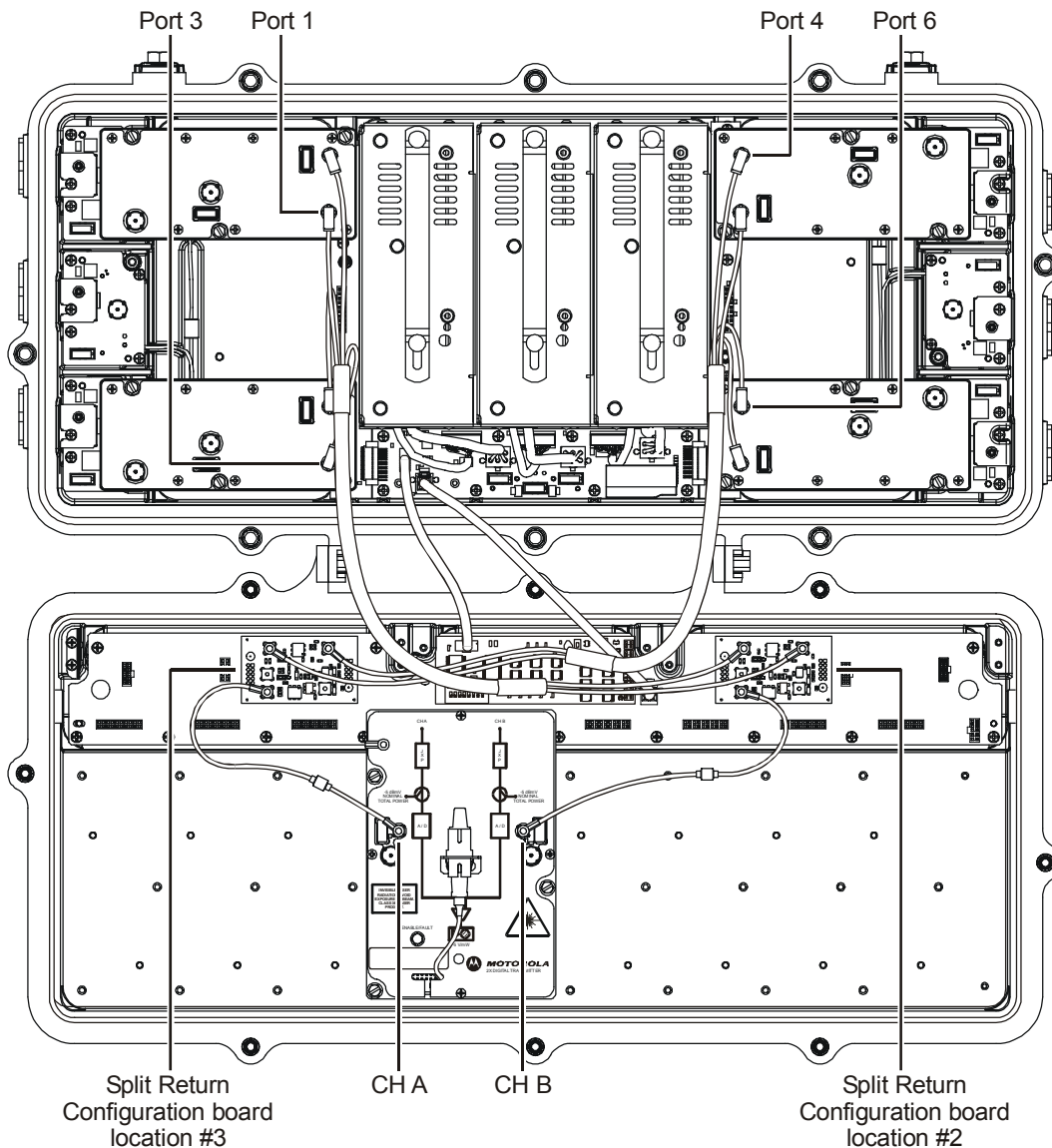

Figure 7 illustrates the 2X redundant return configuration board. Jumpers J5 and J6 are shown in the normal default position. Jumper J6 enables/disables signal flow to output connector J8 (Tx2). Jumper J5 terminates input connector J3 (IN2) when only a single RF input is used.

Figure 7
2X redundant return configuration board

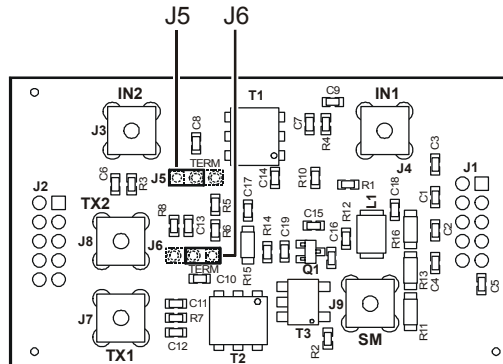
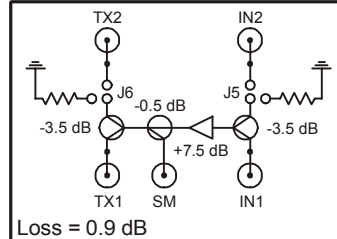

Figure 8 illustrates the signal flow through the 2X redundant return board:

Figure 8
2X redundant return board- signal flow



To set up the split return option:

- 1 Confirm that the SG4-DRT-2X is installed in lid optics slots 3 and 4, or 5 and 6.
- 2 Confirm that a 2X redundant return board is installed in lid return configuration board locations 2 and 3 as illustrated in Figure 5.
- 3 Position J6 in the right-most position to terminate the output to transmitter two.
- 4 Connect an RF cable from the 2X redundant return board, in lid return configuration board location 2, to CH B of the SG4-DRT-2X .
- 5 Connect an RF cable from the 2X redundant return board, in lid return configuration board location 3, to CH A of the SG4-DRT-2X.

The RF cables should be approximately eight inches long and have red boots on the connector signifying the return path.

- 6 If necessary, connect the appropriate return RF cables from the SG4-RF modules to each 2X redundant board.

- 7 Ensure that the PIC cable is properly connected to the lid and power distribution board in the housing base.
- 8 Route and connect the fiber service cable.
- 9 Apply power to the node. Allow five to ten seconds for the system self-diagnosis to complete.
- 10 Verify that the green LED (ENABLE), located on the top panel of the SG4-DRT-2X is illuminated to confirm enable status.
- 11 Measure the RF power at each channels' test point on the top of the SG4-DRT-2X.

The test point is a -20 dB test point located after the JXP pad location and indicates the level into the transmitter.

- 12 Place the proper JXP pad into each channels' pad facility to achieve the nominal total power level at the test point of -5 dBmV.
- 13 Review return path system levels.

The SG4-DRT-2X is configured to drive the laser to the recommended level ($+15$ dBmV) when the total combined power at the housing ports connected to the split return board is approximately ($+28$ dBmV).

- 14 Measure the optical power level at the dc test point using a multimeter. The scaled voltage at this test point is 0.5 V/mW.

Split Redundant Return

In the split redundant return configuration, each pair of RF returns is applied to a separate 2X redundant return configuration board. In a typical installation, the RF module in Ports 1 and 3 are connected to the 2X redundant return board in configuration location 2. The RF modules in Ports 4 and 6 are connected to the 2X redundant return board in configuration location 3. Both outputs of each 2X redundant board go to the same RF input channel on two different SG4-DRT-2X transmitters located in lid optics slots 3 and 4, and 5 and 6.

Figure 9 illustrates the split redundant return configuration:

Figure 9
Split redundant return configuration

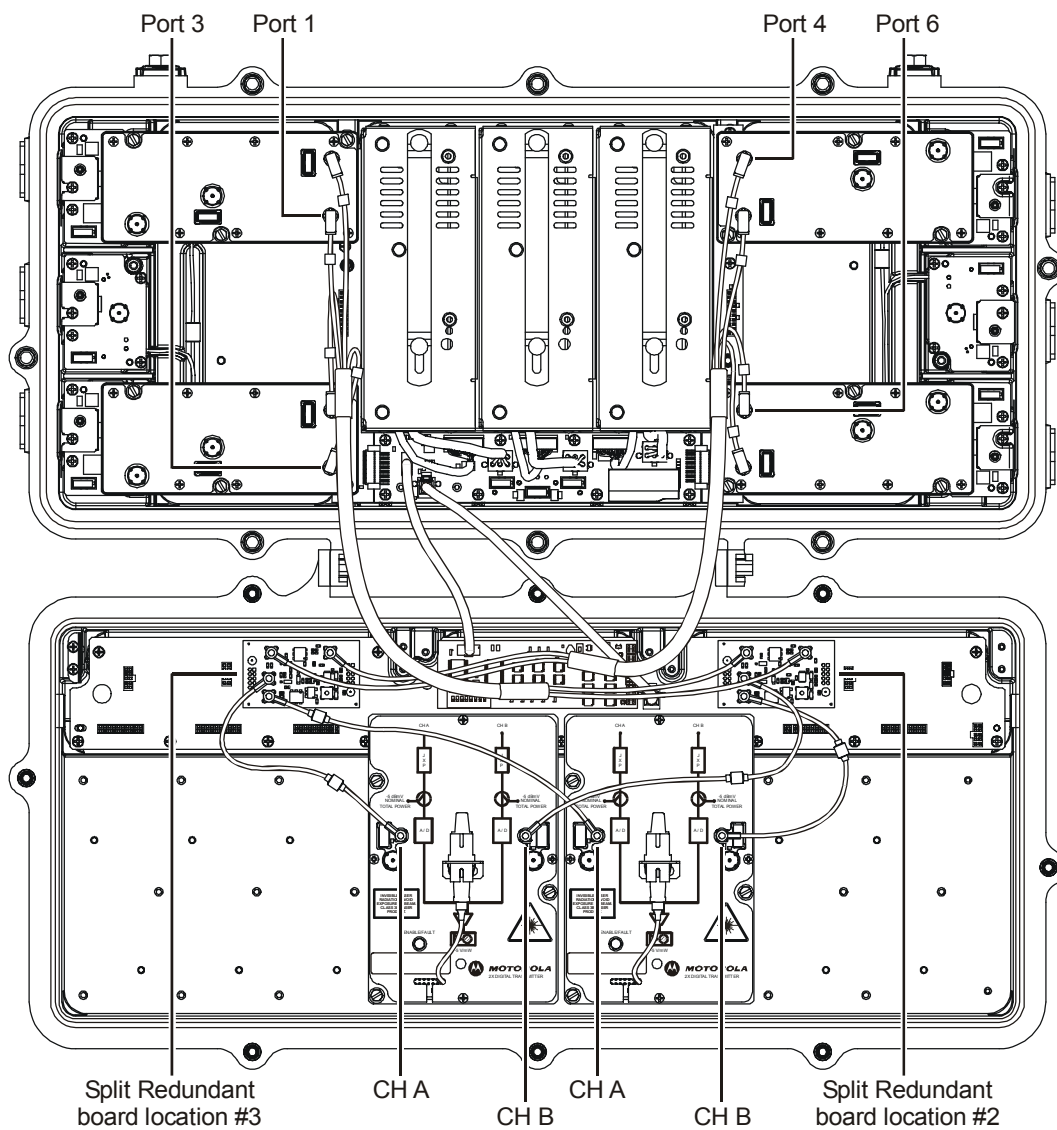

Figure 10 illustrates the plug-in board required for the 2X redundant return option. Jumpers J5 and J6 are shown in the correct position. Jumper J6 enables signal flow to output connector J8 (Tx2) when in the left-most position. Jumper J5 terminates input connector J3 (IN2) when only a single RF input is used.

Figure 10
2X redundant return board

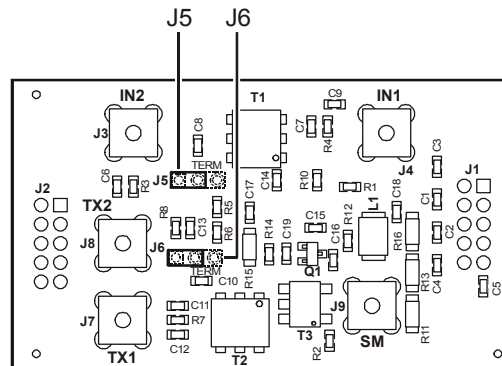
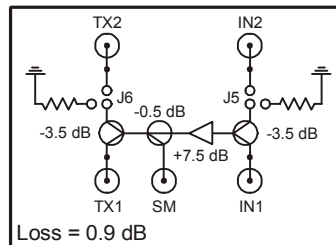

Figure 11 illustrates the signal flow through the 2X redundant return board:

Figure 11
2X redundant return – signal flow



To set up the split redundant return option:

- 1 Confirm that SG4-DRT-2X transmitters are installed in lid optics slots 3 and 4, and 5 and 6.
- 2 Confirm that a 2X redundant return board is installed in return configuration locations 2 and 3 as illustrated in Figure 8.
- 3 Position J6 in the left-most position on each configuration board to enable the output to Tx2.
- 4 Connect an RF cable from connector TX1 on the 2X redundant return board in configuration location 2 to CH B of the transmitter in lid optics slots 3 and 4.
- 5 Connect a second RF cable from connector TX2 on the 2X redundant return board in configuration location 2 to CH B of the transmitter in lid optics slots 5 and 6.
- 6 Connect an RF cable from connector TX1 on the 2X return redundant board in configuration location 3 to CH A of the transmitter in lid optics slots 3 and 4.
- 7 Connect a second RF cable from connector TX2 on the 2X return redundant board in configuration location 3 to CH A of the transmitter in lid optics slots 5 and 6.

The RF cable should be approximately eight inches long and have red boots on the connector signifying the return path.

- 8 If necessary, connect the appropriate return RF cables from the SG4-RF modules to each 2X redundant return board.
- 9 Ensure that the PIC cable is properly connected to the lid and power distribution board in the housing base.
- 10 Route and connect the fiber service cable.
- 11 Apply power to the node. Allow five to ten seconds for the system self-diagnosis to complete.
- 12 Verify that the green LED (ENABLE), located on the top panel of each SG4-DRT-2X is illuminated to confirm enable status.

- 11 Measure the RF power at each channels test point on the top of each SG4-DRT-2X.

The test point is a -20 dB test point located after the JXP pad location and indicates the level into the SG4-DRT-2X.

- 12 Place the proper JXP pad into each SG4-DRT-2X pad facility to achieve the nominal total power level at the test point of -5 dBmV.
- 13 Review return path system levels.

The SG4-DRT-2X is configured to drive the laser to the recommended level (+15 dBmV) when the total combined power at the housing ports connected to the 2X redundant return board is approximately +28 dBmV.

- 14 Measure the optical power level at the dc test point using a multimeter. The scaled voltage at this test point is 0.5V/mW.

Segmented Return

In the segmented return configuration each RF return is applied to an individual RF input on two SG4-DRT-2X transmitters. Two segmented return boards are required. The segmented return boards contain two independent RF paths. In a typical installation, the RF modules in Ports 1 and 3 are connected to the segmented return board in return configuration location 2. The RF modules in Ports 4 and 6 are connected to the segmented return board in return configuration location 3. The segmented return board installed in return configuration location 2 directs RF to channels A and B on the SG4-DRT-2X located in lid optics slots 3 and 4. The segmented return board in return configuration location 3 directs RF to channels A and B on the SG4-DRT-2X located in lid optics slots 5 and 6.

Figure 12 illustrates the segmented return configuration:

Figure 12
Segmented return configuration

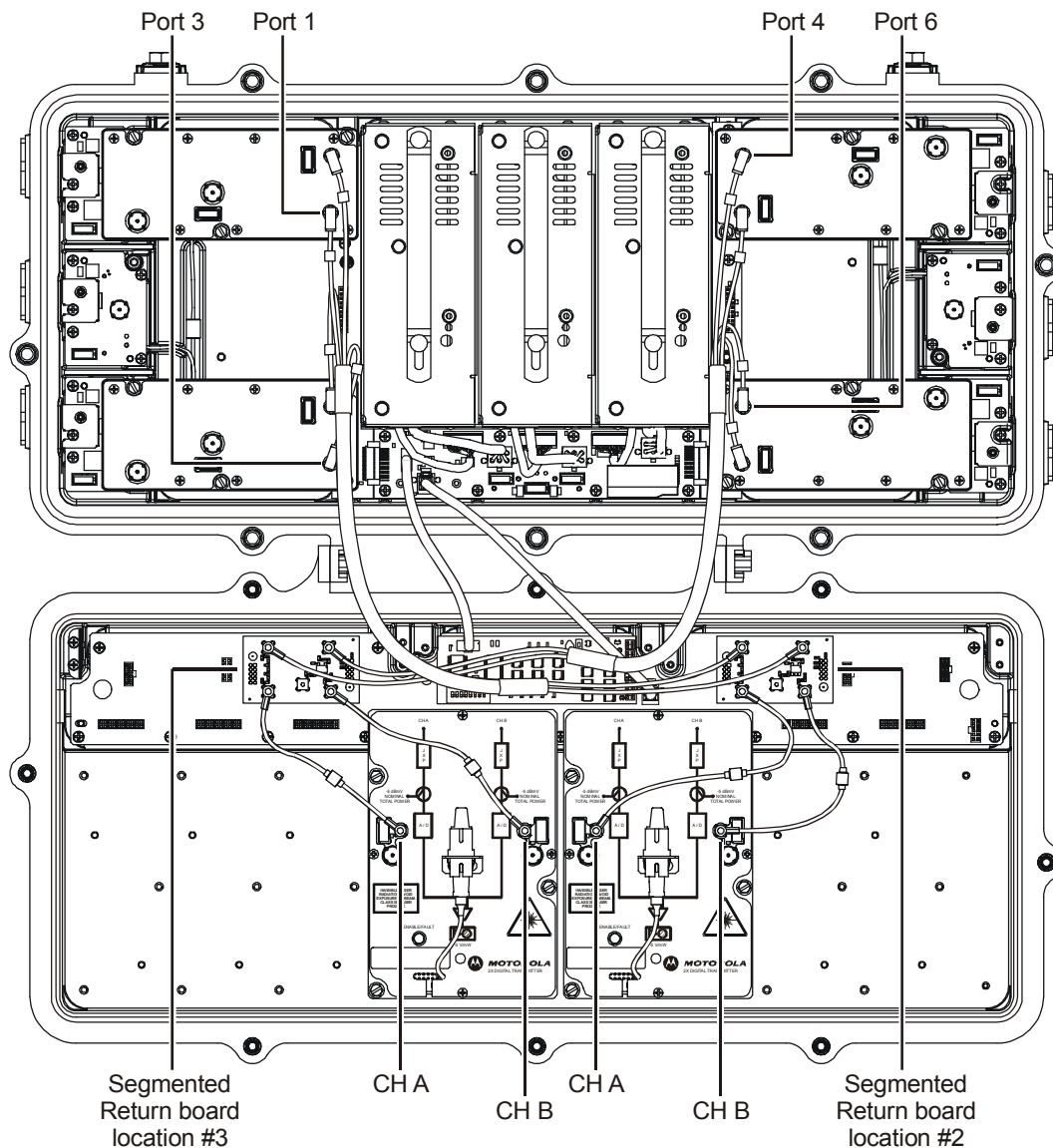

Figure 13 illustrates the segmented return plug-in board.

Figure 13
Segmented return board

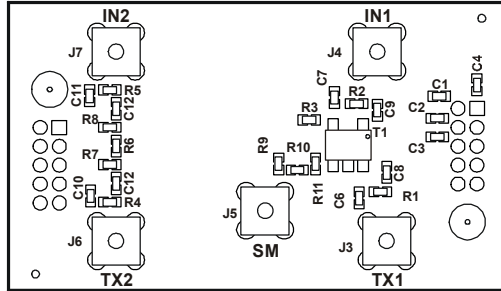
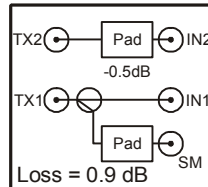

Figure 14 illustrates the signal flow through the segmented return board:

Figure 14
Segmented return board – signal flow



To set up the segmented return option:

- 1 Confirm that dual SG4-DRT-2X return transmitters are installed in lid optics slots 3 and 4 and 5 and 6.
- 2 Confirm that a segmented return board is installed in the return configuration locations 2 and 3 as illustrated in Figure 11.
- 3 Connect an RF cable from connector TX1 on the segmented return board in configuration location 2 to CH B of the SG4-DRT-2X in lid optics slots 3 and 4.
- 4 Connect an RF cable from connector TX2 on the segmented return board in configuration location 2 to CH A of the SG4-DRT-2X in lid optics slots 3 and 4.
- 5 Connect an RF cable from connector TX1 on the segmented return board in configuration location 3 to CH B of the SG4-DRT-2X in lid optics slots 5 and 6.
- 6 Connect an RF cable from connector TX2 on the segmented return board in configuration location 3 to CH A of the SG4-DRT-2X in lid optics slots 5 and 6.

The RF cable should be approximately eight inches long and have red boots on the connector signifying the return path.

- 7 If necessary, connect the appropriate return RF cables from the SG4-RF modules to each segmented return board.
- 8 Ensure that the PIC cable is properly connected to the lid and power distribution board in the housing base.

- 9 Route and connect the fiber service cable.
- 10 Apply power to the node. Allow five to ten seconds for the system self-diagnosis to complete.
- 11 Verify that the green LED (ENABLE), located on the top panel of each SG4-DRT-2X, is illuminated to confirm enable status.
- 12 Measure the RF power at each channels test point on the top of each SG4-DRT-2X.

The test point is a -20 dB test point located after the JXP pad location and indicates the level into the SG4-DRT-2X.
- 13 Place the proper JXP pad into each channels pad facility to achieve the nominal total power level at the test point of -5 dBmV.
- 14 Review return-path system levels.

The SG4-DRT-2X is configured to drive the laser to the recommended level ($+15$ dBmV) when the total combined power at the housing ports connected to each leg of the segmented return board is approximately $+28$ dBmV.
- 15 Measure the optical power level at the dc test point using a multimeter. The scaled voltage at this test point is 0.5 V/mW.
- 16 Secure all cables and fibers.
- 17 Close the housing and use a torque wrench to progressively tighten the housing bolts to a final torque of 12 ft-lbs. in the sequence stamped on the housing lid.

For more specific information regarding return path setup procedures, refer to the supplemental document *Return Path Level Selection, Setup, and Alignment Procedure*.

Specifications

Specifications are valid over the given bandpass and operating temperature range of -40°F to $+140^{\circ}\text{F}$ (-40°C to $+60^{\circ}\text{C}$). Specifications are stated typical unless otherwise noted, and are subject to change. Refer to the Motorola BCS web site or contact your account representative for the latest specifications.

Parameter	Specification
Wavelengths	See the following table (SG4-DRT-2X Models)
Wavelength stability	± 0.1 nm maximum
RF bandwidth	5 MHz to 65 MHz
Number of input channels	2
Input level	15 dBmV total power
Input impedance	75 ohms
Input return loss	>16 dB
Output power	8 dBm
Noise Power Ratio (dB over dynamic range)	40/13 dB, typical 25°C , 100 km fiber
Power input	+24 Vdc
Power consumption	15 W maximum
Operating temperature range	-40 to $+75^{\circ}\text{C}$
Dimensions	3.5" (H) \times 2" (W) \times 6" (D)
Weight	1.8 lbs

SG4-DRT-2X Models

Model	Wavelength (nm)	Model	Wavelength (nm)
SG4-DRT-2X-CH20	1561.65	SG4-DRT-2X-CH40	1545.32
SG4-DRT-2X-CH21	1560.61	SG4-DRT-2X-CH41	1544.53
SG4-DRT-2X-CH22	1559.79	SG4-DRT-2X-CH42	1543.73
SG4-DRT-2X-CH23	1558.98	SG4-DRT-2X-CH43	1542.94
SG4-DRT-2X-CH24	1558.17	SG4-DRT-2X-CH44	1542.14
SG4-DRT-2X-CH25	1557.36	SG4-DRT-2X-CH45	1541.35
SG4-DRT-2X-CH26	1556.56	SG4-DRT-2X-CH46	1540.56
SG4-DRT-2X-CH27	1555.75	SG4-DRT-2X-CH47	1539.77
SG4-DRT-2X-CH28	1554.94	SG4-DRT-2X-CH48	1538.98
SG4-DRT-2X-CH29	1554.13	SG4-DRT-2X-CH49	1538.19
SG4-DRT-2X-CH30	1553.33	SG4-DRT-2X-CH50	1537.40
SG4-DRT-2X-CH31	1552.52	SG4-DRT-2X-CH51	1536.61
SG4-DRT-2X-CH32	1551.72	SG4-DRT-2X-CH52	1535.82
SG4-DRT-2X-CH33	1550.92	SG4-DRT-2X-CH53	1535.04
SG4-DRT-2X-CH34	1550.12	SG4-DRT-2X-CH54	1534.25
SG4-DRT-2X-CH35	1549.32	SG4-DRT-2X-CH55	1533.47
SG4-DRT-2X-CH36	1548.51	SG4-DRT-2X-CH56	1532.68
SG4-DRT-2X-CH37	1547.72	SG4-DRT-2X-CH57	1531.90
SG4-DRT-2X-CH38	1546.92	SG4-DRT-2X-CH58	1531.12
SG4-DRT-2X-CH39	1546.12	SG4-DRT-2X-CH59	1530.33
		SG4-DRT-2X-CH60	1529.55

If You Need Help

If you need assistance while working with the SG4-DRT-2X, contact the Motorola Technical Response Center (TRC):

- Inside the U.S.: 1-888-944-HELP (1-888-944-4357)
- Outside the U.S.: **215-323-0044**
- Motorola Online: <http://businessonline.motorola.com>

The TRC is open from 8:00 AM to 7:00 PM Eastern Time, Monday through Friday and 10:00 AM to 5:00 PM Eastern Time, Saturday. When the TRC is closed, emergency service *only* is available on a call-back basis. Motorola Online offers a searchable solutions database, technical documentation, and low priority issue creation/tracking 24 hours per day, 7 days per week.

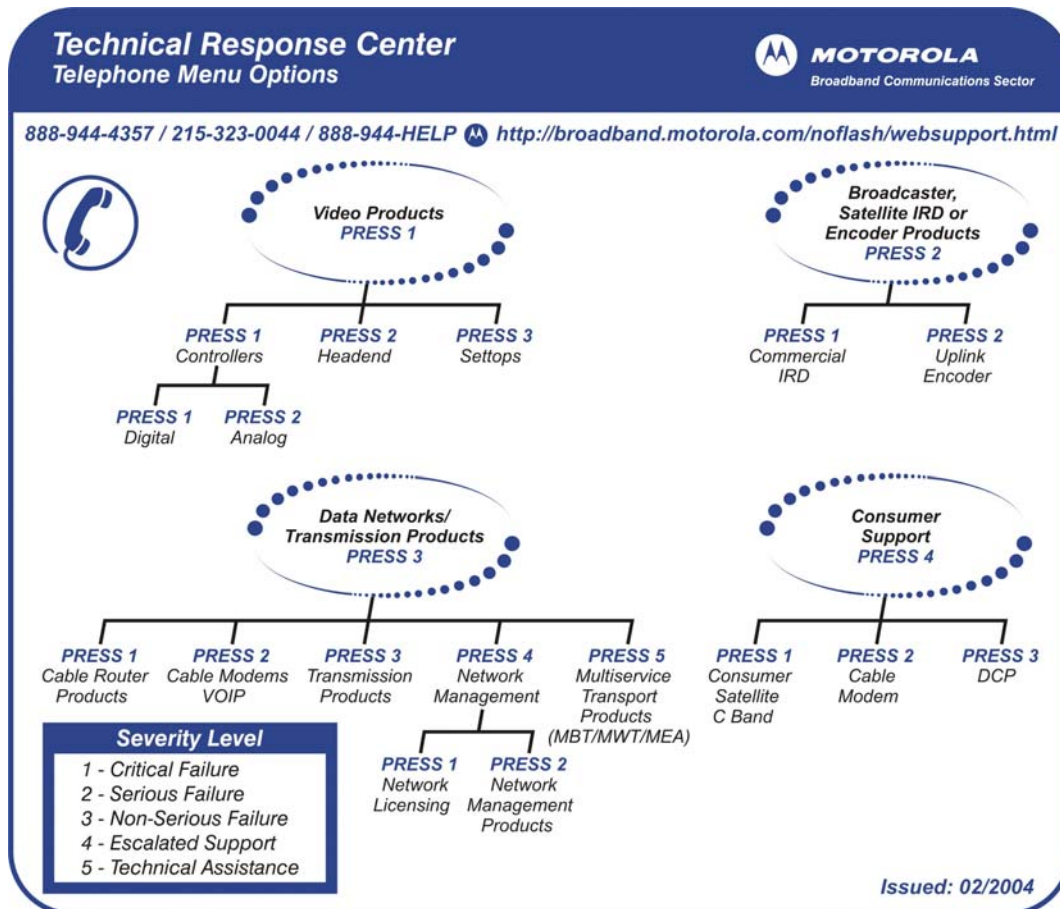

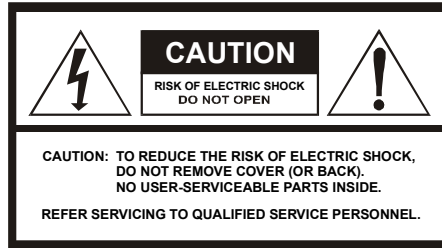

Caution

These servicing instructions are for use by qualified personnel only. To reduce the risk of electrical shock, do not perform any servicing other than that contained in the Installation and Troubleshooting Instructions unless you are qualified to do so. Refer all servicing to qualified service personnel.

Special Symbols That Might Appear on the Equipment

	<p>This is a class 1 product that contains a class IIIb laser and is intended for operation in a closed environment with fiber attached. Do not look into the optical connector of the transmitter with power applied. Laser output is invisible, and eye damage can result. Do not defeat safety features that prevent looking into optical connector.</p>
	<p>This product contains a class IIIb laser and is intended for operation in a closed environment with fiber attached. Do not look into the optical connector of the transmitter with power applied. Laser output is invisible, and eye damage can result. Do not defeat safety features that prevent looking into optical connector.</p>
	<p>For continued protection against fire, replace all fuses only with fuses having the same electrical ratings marked at the location of the fuse.</p>

MOTOROLA, the Stylized M Logo, and STARLINE are registered in the US Patent & Trademark Office. All other product or service names are the property of their respective owners. © Motorola, Inc. 2004.

<p>509978-001 8/04</p>	<p>All rights reserved. No part of the contents of this manual may be reproduced or transmitted in any form or by any means without the written permission of the publisher.</p>
----------------------------	--

Free Manuals Download Website

<http://myh66.com>

<http://usermanuals.us>

<http://www.somanuals.com>

<http://www.4manuals.cc>

<http://www.manual-lib.com>

<http://www.404manual.com>

<http://www.luxmanual.com>

<http://aubethermostatmanual.com>

Golf course search by state

<http://golfingnear.com>

Email search by domain

<http://emailbydomain.com>

Auto manuals search

<http://auto.somanuals.com>

TV manuals search

<http://tv.somanuals.com>