



Digital Users Manual

This manual describes the Cox Interactive Program Guide with Motorola's Digital Converter Terminal (DCT) and remote control.

Your remote control may be slightly different. Although general functionality is the same, you may wish to refer to the instructions that came with your remote control rather than the ones described within this manual.

Important Tips for Safe Operation

Don't move your DCT

Your Cox Digital Converter Terminal (DCT) is really a computer that communicates with our network. It is set up to operate from only one cable outlet in your home. If you move your DCT, it is possible that it will not work properly in its new location. If you must move your settop equipment for any reason, please contact Cox Customer Service at the number provided at the front of this guide for instructions.

Read and retain your User Manual

Read all of the instructions before you operate this equipment. Give particular attention to the safety precautions. You'll find your Cox Digital Cable User Manual is a user-friendly reference for any questions you may have.

Safeguard your equipment

Avoid personal injury and damage to your equipment. Place all electronic equipment on a stable surface that is sturdy enough to support the size and weight of your equipment. Be sure your equipment is always located close enough to an electrical outlet to accommodate the length of the power cord.

▲ **CAUTION:** An overextended cord can cause wires to fray and fail.

▲ **CAUTION:** An unstable surface can cause equipment to fall.

Keep your equipment clean

Dust can interfere with the performance of electronic equipment; and so can cleaning supplies! Do not use a liquid cleaner or an aerosol cleaner directly on the surfaces. Use a damp cloth to clean this equipment.

▲ **CAUTION:** Be sure to unplug all equipment from the electrical outlet before cleaning.

▲ **CAUTION:** Dust removers, or any magnetic/static cleaning device may harm your equipment.

Avoid contact with liquid or moisture

Placing your equipment on a wet surface or placing wet objects, such as plants or beverages, on top of your equipment can cause electrical damage.

Introducing Cox Interactive Program GuideSM

The Cox Interactive Program Guide (IPG) provides you with the following features:

- **Channel Banner**

This is a graphic that displays at the bottom of your TV screen. It shows program information for the currently tuned program. You can “browse” with the channel banner to display program information for programs and channels other than the one you are tuned to.

- **Program Guide**

The Program Guide shows what’s on TV. You can also use it to tune to programs, to set timers, purchase Pay-Per-View (PPV) programs and access On Demand programming.

- **Settings Menu**

The Settings Menu allows you to set many Cox Interactive Program Guide preferences, such as Parental Control, cable settop preferences, favorite channels, and skipped channels.

- **Parental Control**

Parental Control allows you to restrict the channels, ratings, and time periods your household members can watch.

- **Cox iN DEMAND (Pay-Per-View)**

Pay-Per-View allows you to purchase Pay-Per-View programs and to set a PIN number to restrict who can purchase.

- **On Demand**

With On Demand, exclusively on Cox Digital Cable, you have 100’s of programs to choose from. Start them whenever you want and enjoy pause, rewind and fast-forward functionality through your remote. And when you subscribe to HBO, Cinemax or Starz get free unlimited access to their library of On Demand programming. Plus you can also access exclusive Local On Demand programming or rent box office hits with Movies On Demand. With On Demand there is always something on.

About this manual

This manual helps you to start using the Cox Interactive Program Guide by including the instructions for the following:

- Using the remote control to turn on/off the TV, VCR, and cable settop, and displaying the channel banner.
- Using the Program Guide, including displaying it, navigating in it, and searching program information by theme and title.
- Specifying menu settings, such as Favorite and Skipped channels, Parental Control settings, and receiver preferences.
- Setting up Parental Control, including changing the PIN, specifying which channels, ratings, and time periods you want locked, and activating Parental Control.
- Purchasing and canceling Pay-Per-View programs. You can also set purchasing up so that household members must enter the PIN before they can purchase programs.

DCT 2000 front panel

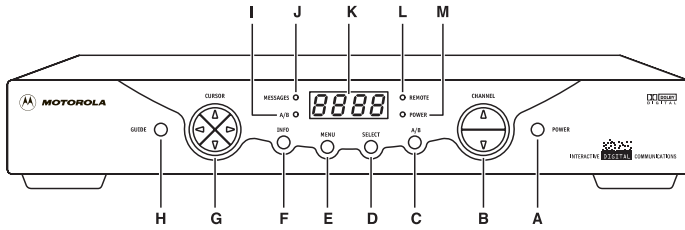

Your receiver terminal may vary.

Key	Function
A	Turns terminal on/off
B	Changes channel up or down
C	When enabled, this switches an add-on module from one function to another function
D	Selects function options and Pay-Per-View events and tunes channels from the electronic Program Guide
E	Displays Main Menu
F	Displays current channel and program information
G	Moves the cursor in Menu and Program Guide screens
H	Displays the Interactive Program Guide
I	Lights if optional switch is activated
J	Lights to indicate that a message is present*
K	Normally displays current channel number or time; in the diagnostic mode, displays diagnostic codes
L	Flashes when an error-free signal is received from the remote control
M	Lights when unit is on

*Option may not be available in your area.

DCT 2500 front panel

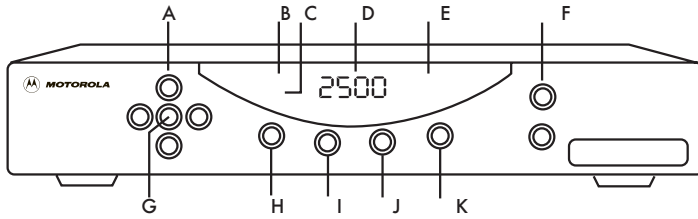

Your receiver terminal may vary.

Key	Function
A	Moves the cursor in menus and electronic program guide screens
B	Lights to indicate that a message is present
C	Lights when the unit is turned on
D	Displays current channel number or time of day
E	Flashes when a signal is received from the remote control
F	Changes the channel up and down
G	Selects menu options, Pay-Per-View (PPV) events, and tunes channels from the electronic program guide
H	Turns the DCT2500 on and off
I	Displays the main menu
J	Displays current channel and program information
K	Displays the electronic program guide

Getting Started

This section describes how to use the remote control to turn on the TV, receiver and VCR, as well as display and use the channel banner and Program Guide.

About the remote control

Your Cox Digital Cable smart remote allows you to control not only your receiver, but also your TV, VCR and audio component. For information on programming your remote, please refer to the user manual that you received with your remote. Simply press the button on your remote for the component you want to use, then whatever function keys you desire. The remote will “remember” which component you want to operate until you tell it differently.

For example, if you want to turn the VCR on and play a tape, simply press the VCR button on the remote, then the power button, then use the remote keys to control the VCR. (Remember that many of the VCR function keys—like Play, Stop, Rewind—may be hidden under a sliding compartment in some models.) When you’re done using the VCR and want to return to watching Cox Digital Cable, simply press the CABLE button on the remote and return to normal use. (Always remember to point the remote at the receiver if you are using it to control Cox Digital Cable.)

Your remote may vary slightly, but basic functionality is the same. See the following remote control diagrams on page 10 to reference the remote model that you have.

Basic Operations

Turning on the TV, receiver, and VCR

To turn on the TV

- Press the **TV** button, then the **POWER** button. The TV turns on.

To turn on receiver

- Press the **CABLE** button, then the **POWER** button. The receiver turns on.

To turn on the VCR

- Press the **VCR** button, then the **POWER** button. The VCR turns on.

Changing channels

- If you know the channel number, enter the number using the numbered buttons. Press the **SELECT** button for immediate tuning.
- To go one channel up from the current channel, press **CH +** or the top **CHANNEL** button.
- To go one channel down from the current channel, press **CH -** or the bottom **CHANNEL** button.
- To see the previously tuned channel press the **LAST** button.
- To see the next channel that you specified as a favorite channel, press the **FAV** button. For more information, refer to Choosing Menu Settings on page 18.

Adjusting the volume level

- To increase the volume, press **VOL +** or the top **VOL** button.
- To decrease the volume, press **VOL -** or the bottom **VOL** button.
- To turn the volume off completely, press the **MUTE** button.
- To restore the volume and continue listening to the program, press the **MUTE** button again.

General Setup



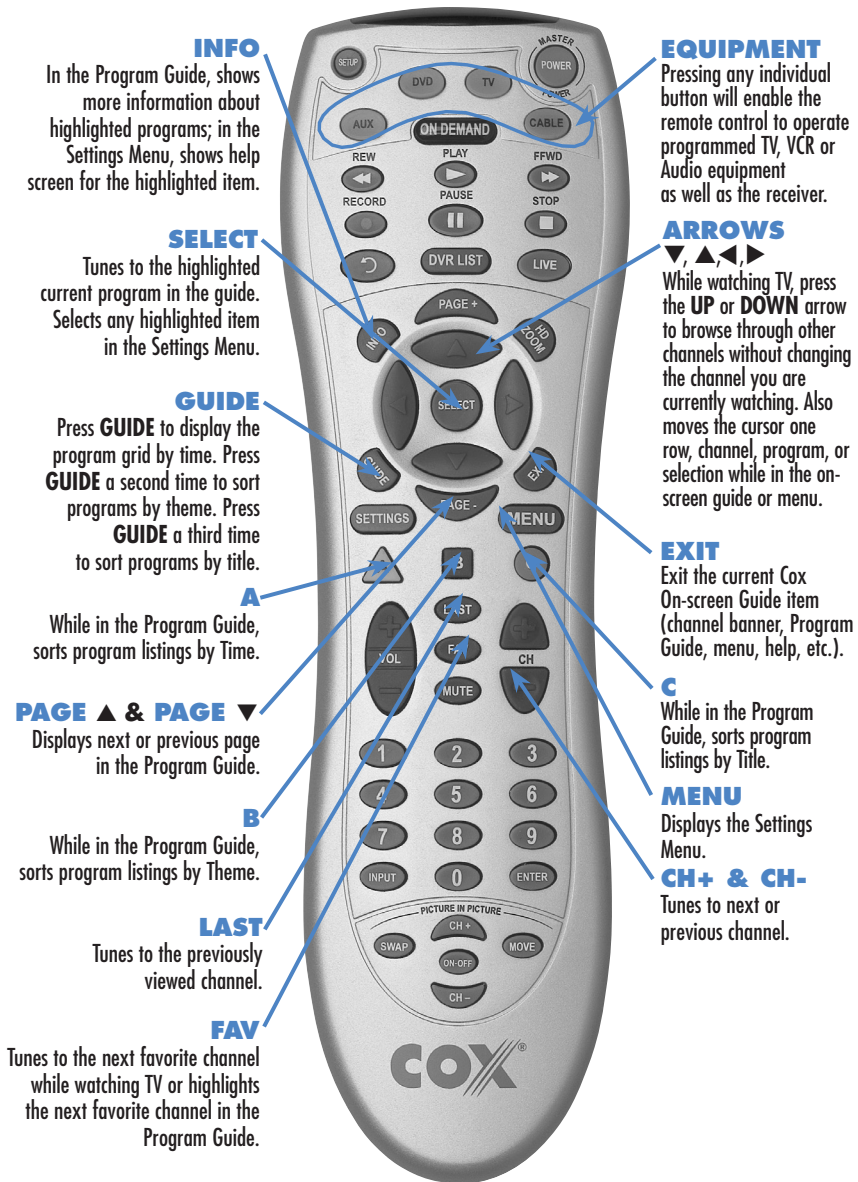





Remote A (Universal)



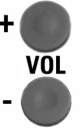



General Setup

The table below lists some additional remote control buttons with a description of each.

Press this button To

-  Turn the selected device on or off
-  Turn the volume off or on
-  Adjust the volume - press "+" to increase the volume level; press "-" to decrease the volume level
-  Bypass the receiver to tune directly on the TV
-  View Program Guide information for the previous day, where available
-  View Program Guide information one day ahead
-  Activate VCR's TV/VCR switch
-  Rewinds in VCR/DVD Mode or On Demand* programs. Jumps to previous day in Program Guide.

Press this button To

-  Plays in VCR/DVD Mode or On Demand* programs.
-  Fast Forwards in VCR/DVD Mode or On Demand* programs. Advances 24 hours forward in Program Guide.
-  Records in VCR Mode.
-  Stops in VCR/DVD Mode or On Demand* programs.
-  Pauses in VCR/DVD Mode or On Demand* programs.

Using the Program Guide

The Cox Interactive Program Guide_{sm} (IPG) gives you an overview of what is playing on different channels during the day. From the Program Guide, you can get information about programs, tune to a program, set timers, and purchase programs. The figure below shows the Program Guide.

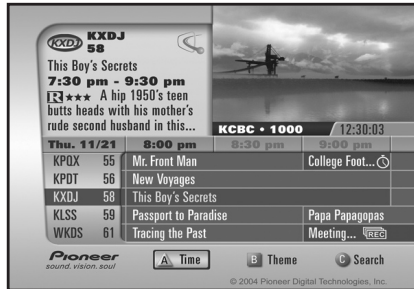

Actual programming may vary.

The Program Guide shows you:

- The station call letters and channel number of the currently highlighted program.
- The title, start and end time, rating, a brief description of the currently highlighted program, and symbols if appropriate. For symbols, refer to page 20.
- The time grid or a list of programs by theme or title.

Displaying the Program Guide

1. Press the **GUIDE** button. The Program Guide shows the time grid. The currently tuned program is highlighted in the time grid.

Note: To display information in the Program Guide for a day ahead, press the **DAY+** or **FAST FORWARD** button. To display information for the previous day, press the **DAY-** or **REWIND** button. These features are not available in all areas.

Using the Program Guide

Tuning to a program from the Program Guide

1. In the Program Guide, press the arrow buttons to highlight the program you want to tune to, or press the numbered buttons to enter the channel number. This highlights the current program for that channel.
2. Press the **SELECT** button to tune to the program. The Program Guide disappears and the selected program appears.

Note: If the program you selected is a future program, you will see a message asking if you want to set a timer. Press the button indicated if you wish to choose this option.

3. Press **GUIDE** to return to the Program Guide.

Viewing more information about a program

You can use the Program Guide to get additional information about a program.

1. In the Program Guide, press the arrow buttons to highlight the program for which you want more information.
2. Press the **INFO** button. The Cox Program Guide displays an extended description of the selected program.
3. To exit the extended description, press the **EXIT** button.

The screen below shows an example of additional information in the Program Guide.

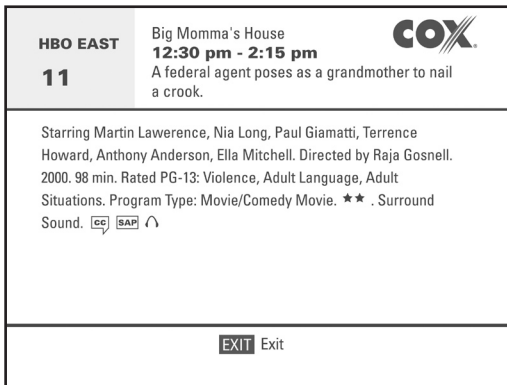

Actual programming may vary.

Using the Program Guide

Displaying the Program Guide by Theme

1. In the Program Guide, press the **GUIDE** button multiple times until **THEME** is highlighted at the bottom of the screen. A list of themes appears for you to select from.
2. Press the **UP** or **DOWN** arrow button to scroll through the list of themes. For each theme highlighted, the Program Guide displays all available programs for that theme in the column on the right.
3. Press the **RIGHT** arrow button. Then press the **UP** or **DOWN** button to scroll through the list.

Displaying the Program Guide by Title

1. In the Program Guide, press the **GUIDE** button multiple times until **TITLE** is highlighted. An alphabetical list of letters appears.
2. Press the **UP** or **DOWN** arrow button to highlight the first letter of the program title for which you want to view information. For each letter highlighted at the bottom screen, the Program Guide displays all available programs for that letter in the column on the right.
3. Press the **RIGHT** arrow button. Then press the **UP** or **DOWN** button to scroll through the list.

Exiting the Program Guide

1. To exit the Program Guide, press the **EXIT** button.

Using the Program Guide

Displaying and browsing with the channel banner

The Cox Interactive Program Guide_{sm} includes a channel banner to provide quick access to information about the program title and the program's start and end times. The figure below shows the channel banner.



Actual programming may vary.

The channel banner shows the following information:

- The channel number and call letters
- The program title, start time, and end time
- The current time
- Program Guide symbols where appropriate (for example, the star symbol for a favorite channel)

You can browse program title and time information with the channel banner. This allows you to continue watching the current program while checking program information for other channels and other times.

The following procedure describes how to display and browse the channel banner.

Note: The channel banner automatically displays when you change channels.

Using the Program Guide

To display the channel banner

1. While watching a program, press the **INFO** button. The channel banner displays.
2. To browse other channel programming info, such as program titles and times, use the arrow buttons as shown below.
 - ▲ View programming info for next channel up from what is on channel banner.
 - ▼ View programming info for next channel down from what is on channel banner.
 - ▶ View info on next program scheduled from what is on channel banner.
 - ◀ View info on prior program scheduled from what is on channel banner.
3. To tune to a channel shown in the channel banner, press the **SELECT** button.

Setting a timer to tune to a future program

1. Press **GUIDE**.
2. Use **UP**, **DOWN** and **RIGHT** buttons to highlight a future program.
3. Press **SELECT**. If the PIN is required for purchasing or if Parental Control is selected for this program, a screen appears asking you for the PIN. Enter PIN.
4. Press **SELECT** again to set the timer. The selected program background will turn red in the guide. You can check all pre-selected programs in the Settings Menu under Timer Review.

Note: If you currently purchased a PPV movie, you cannot set a timer during this movie.

Note: You can only set one timer per time frame. Time frames cannot overlap.

Using the Program Guide

Understanding the Cox Interactive Program Guide symbols

There are several symbols that you may see in the on-screen guide, for example, a star in the Settings Menu. The table below describes each symbol.

This symbol Indicates



A program locked by channel, rating, or time period with Parental Control currently locked



A program locked by channel, rating, or time period with Parental Control currently unlocked



A channel marked as a favorite channel



A channel marked as a skipped channel

This symbol Indicates



A program with stereo sound



A program with closed caption information (subtitles for hearing-impaired viewers)



A program with secondary audio; viewers can choose to hear audio in another language



A program that has been purchased



A program with a timer

Choosing Menu Settings

The on-screen guide provides a Settings Menu to help you tailor the Cox Interactive Program Guide to your needs. The figure below shows the Settings Menu.

Displaying the Settings Menu

1. Press the **MENU** button. The Settings Menu displays.

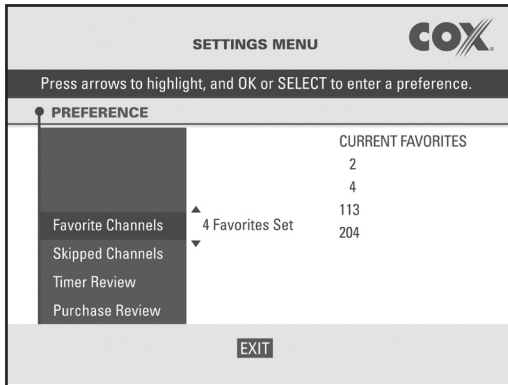

Choosing menu settings

1. In the Settings Menu, press the **UP** or **DOWN** arrow button to highlight the preference you want to specify.
2. Press the **RIGHT** arrow button. The settings for the selection appear in a column to the right.

Note: If you have selected a setting limited by Parental Control, refer to page 26.

3. Press the **UP** or **DOWN** arrow button to select the setting you want to specify. For multiple columns, press the **RIGHT** or **LEFT** arrow button to access the settings menu columns.
4. Press the **SELECT** button to select the setting.

The table on the next page shows all the Settings Menu preferences you can specify and gives a brief description of each preference.

Choosing Menu Settings

This preference	Lets you	This preference	Lets you
Favorite Channels	Specify channels as favorites; you can tune to them with the FAV button	Parental Control: Lock Ratings	Specify the program ratings you want to lock when Parental Control is on
Skipped Channels	Specify channels that you want to skip while tuning with the CH (+/-) button	Parental Control: Lock channels	Specify the channels you want to lock when Parental Control is on
Timer Review	Review and cancel pending timers and PPV purchases	Parental Control: Lock time	Specify a time period to lock when Parental Control is on
Purchase Review	Review and cancel PPV purchases	Audio	Specify the receiver's audio modes such as a language, the volume level, sound options and compression levels
Parental Control: Change PIN	Change the number for the PIN you use for Parental Control and purchasing	Clock Options	Specify whether the receiver LED displays the time, the current channel, or channel numbers while you are tuning
Parental Control: Purchasing	Specify whether you want to require household members to enter the PIN to purchase programs	AC Outlet Use	Specify the power settings for the receiver's AC outlet
Parental Control: Locking	Specify whether you want to turn Parental Control locking on/off or off temporarily.		

Choosing Menu Settings

Getting help for menu preferences

1. Press **MENU**
2. Press the **UP** or **DOWN** arrow button to highlight the preference for which you want help.
3. Press the **INFO** button. A message shows a description of the preference.
4. To exit the help screen, press the **EXIT** button.

Exiting the Settings Menu

1. Press the **EXIT** button. The Settings Menu disappears and you return to the channel you were watching.

How to use Language Settings

Use this feature to select the language you want to use for channels over 100 (digital channels) that support more than one language for audio. The default language is English.

1. Press the **MENU** button. The Settings Menu appears.
2. Press the **UP** or **DOWN** arrow button to highlight the Settop Audio preference.
3. Press the **RIGHT** arrow button and the Language Option appears.
4. Press the **RIGHT** arrow button and the language settings that are available appear.
5. Using the **UP** or **DOWN** arrows, highlight the language that you want.
6. Press **SELECT**.
7. Press **EXIT**. This sets the Language Setting.

Note: For channels below 100 (analog channels), SAP is only available through your TV. To set Second Audio Language on analog channels, please follow the instructions provided by the manufacturer of your TV.

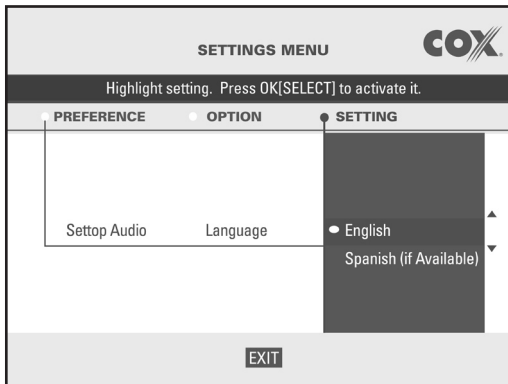

Using Parental Control

The Cox Interactive Program Guidesm provides you with Parental Control so you can restrict PPV purchasing and viewing of specific channels, ratings and programs during a certain time period.

If you tune to a locked program when Parental Control is on, a screen appears informing you that the program is locked. Only those household members who know the PIN can turn Parental Control off and view locked channels or programs.

To set up Parental Control, you will need to:

1. Set up your PIN.
2. Specify channels, ratings and time periods you want to lock.
3. Lock Parental Control. *If you do not lock Parental Control, all channels, ratings and times are available to all household members.* For more information on activating Parental Control, refer to page 28.

Setting up Parental Control

When you set up Parental Control you can specify what channels, rating, or time periods you want to lock. This section describes how to do this.

You need to know your PIN to be able to set up Parental Control. If you forget your PIN, call Cox Customer Service at the number provided at the front of this guide. If you receive a new PIN number your favorite channels and other Setting preferences may need to be reset.

Note: Items that are currently selected for Parental Control locking show a locked or unlocked symbol in the Settings menu. For descriptions of these symbols, refer to page 20.

Set up your PIN

1. Press **MENU**. The Settings Menu displays.
2. Press the **UP** or **DOWN** arrow to highlight the Parental Control preference.
3. Press the **RIGHT** arrow button. The PIN entry screen appears.
4. Enter four digit PIN.
5. Enter your PIN again. (If you make a mistake while entering your PIN, press the **LEFT** arrow button to clear your entry.)
6. Your PIN is now set. Press **EXIT** to resume watching TV.

Using Parental Control

Specify channels and ratings

1. Press the **MENU** button. The Settings Menu appears.
2. Press the **UP** or **DOWN** arrow to highlight the Parental Control preference.
3. Press the **RIGHT** arrow button. The following message appears:

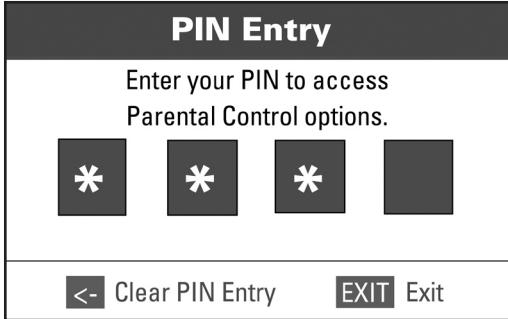

PIN Entry

Enter your PIN to access Parental Control options.

* * * *

<- Clear PIN Entry EXIT Exit

4. Press the numbered buttons to enter the four numbers of your PIN. You now see the Option column.
5. Press the **UP** or **DOWN** arrow button to highlight the Lock Channels or Lock Ratings option.
6. Press the **RIGHT** arrow button. A list of channels or ratings appears.

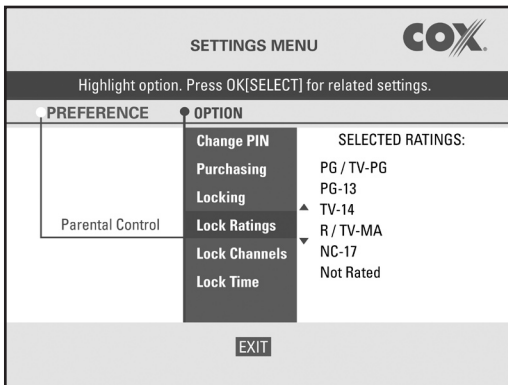

SETTINGS MENU COX

Highlight option. Press OK[SELECT] for related settings.

PREFERENCE	OPTION	SELECTED RATINGS:
Parental Control	Change PIN	PG / TV-PG
	Purchasing	PG-13
	Locking	TV-14
	Lock Ratings	R / TV-MA
	Lock Channels	NC-17
	Lock Time	Not Rated

EXIT

Channels or ratings that are currently selected for locking have a locked or unlocked symbol.

Using Parental Control

7. To lock all channels, select the Lock All option at the top of the channel list.
8. To unlock all channels or ratings, select the Clear All option at the top of the channel list.
9. To lock specific channels or ratings, press the **UP** or **DOWN** arrow button to highlight the channel or rating you want to lock.
10. To lock the highlighted channel or rating press the **SELECT** button.
11. To lock additional items, return to step 9. To unlock this item, press **SELECT** again.
12. To exit the Settings Menu, press the **EXIT** button.
13. To activate Parental Control, refer to page 29.

Specify a time period

1. Press the **MENU** button. The Settings Menu appears.
2. Press the **UP** or **DOWN** arrow button to highlight the Parental Control preference.
3. Press the **RIGHT** arrow button. The following message appears:

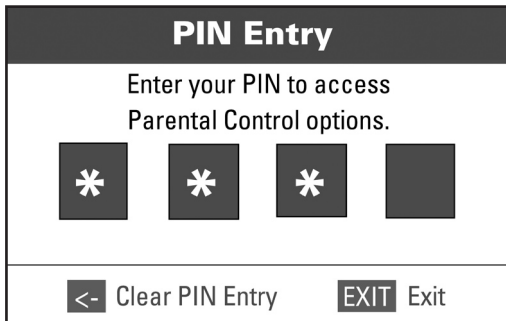

4. Press the numbered buttons to enter the four numbers of your PIN. You now see the Option column.
5. Press the **DOWN** arrow button to highlight the Lock Time option.

Using Parental Control

6. Press the **RIGHT** arrow button. The Start Time menu appears.

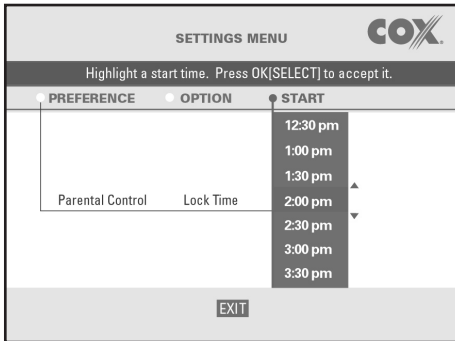

7. To lock a 24-hour period, select the Lock All option.
8. To delete the current time lock, select the Clear All option.
9. To specify the time period to lock, press the **UP** or **DOWN** arrow button to highlight the hour and minutes when you want the locked time period to begin.
10. Press the **SELECT** button to set the start time. The End Time menu appears.
11. Press the **UP** or **DOWN** arrow button to highlight the hour and minutes when you want the locked time period to end.
12. Press the **SELECT** button to set the end time.
13. To exit the Settings Menu, press the **EXIT** button.
14. To lock Parental Control, continue with the section below.

Activating Parental Control

Before you activate Parental Control, you must have specified which channels, ratings, or time period you want to lock.

Using Parental Control

To activate Parental Control

1. Press the **MENU** button. The Settings Menu appears.
2. Press the **UP** or **DOWN** arrow button to highlight the Parental Control preference.
3. Press the **RIGHT** arrow button. The following message appears:

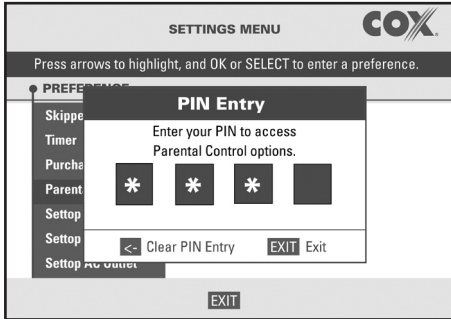

4. Press the numbered buttons to enter the four numbers of your PIN. You now see the Option column.
5. Press the **UP** or **DOWN** arrow button to highlight the Locking option.
6. Press the **RIGHT** arrow button to move to the Setting column.

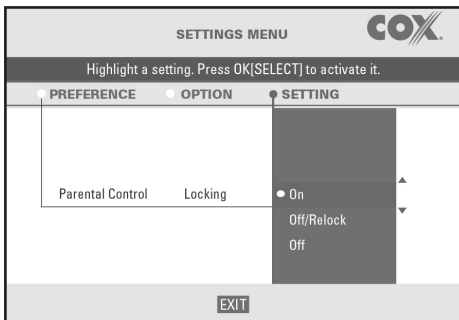

7. Press the **UP** or **DOWN** arrow button to highlight the On option.
8. Press the **SELECT** button. This locks Parental Control. All channels, ratings, and time periods selected for locking are now locked.
9. To exit the Settings Menu, Press the **EXIT** button.

Using Parental Control

Deactivating Parental Control

You can unlock Parental Control permanently or temporarily. When you unlock Parental Control temporarily, it relocks automatically when you turn the settop off and then turn it back on.

Note: If you tune to a locked channel, a pop-up message appears. You then have the option to enter your PIN and unlock all locks.

To unlock Parental Control from the Settings Menu

1. Press the **MENU** button. The Settings Menu appears.
2. Press the **UP** or **DOWN** arrow to highlight the Parental Control preference.
3. Press the **RIGHT** arrow button. The following message appears:

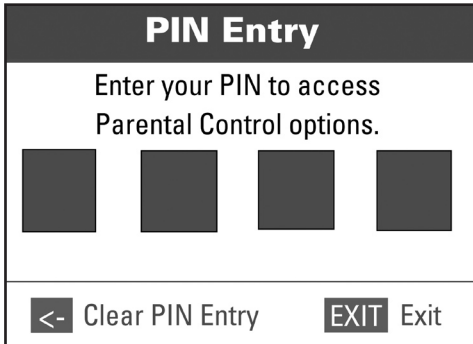

PIN Entry

Enter your PIN to access
Parental Control options.

■ ■ ■ ■

<- Clear PIN Entry EXIT Exit

4. Press the numbered buttons to enter the four numbers of your PIN. You now see the Option column.
5. Press the **UP** or **DOWN** arrow button to highlight the Locking option.
6. Press the **RIGHT** arrow button to move to the Setting column.

Using Parental Control

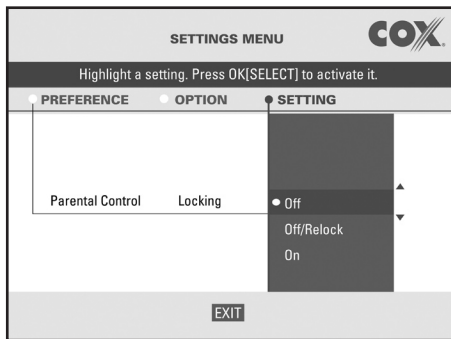

7. Press the **UP** or **DOWN** arrow button to highlight the Off or Off/Relock option.

When you select the Off/Relock option, Parental Control unlocks, but relocks automatically when you turn the settop off and then back on. To relock Parental Control manually, refer to "Activating Parental Control" on page 25.

8. Press the **SELECT** button.
9. Parental Control is now unlocked. To exit the Settings Menu, press the **EXIT** button.

Changing your PIN

1. Press the **MENU** button. The Settings Menu appears.
2. Press the **UP** or **DOWN** arrow to highlight the Parental Control preference.
3. Press the **RIGHT** arrow button. The following message appears:

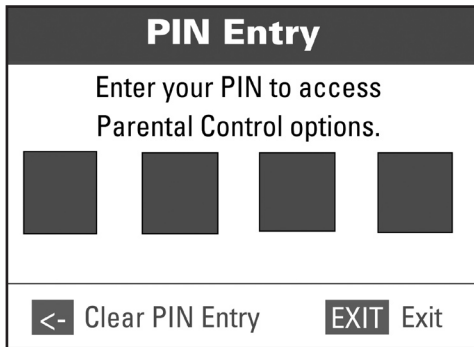

PIN Entry

Enter your PIN to access
Parental Control options.

■ ■ ■ ■

<- Clear PIN Entry **EXIT** Exit

4. Press the numbered buttons to enter the four numbers of your new PIN.
5. Press the numbered buttons to enter the four numbers of your new PIN again.
6. Press the **EXIT** button to accept the message and return to the Settings menu.

ON DEMAND

On Demand is here

Now you can rent movies right from your TV and control them like a VCR. No more late fees. No more hassles with the video store. With On Demand you can:

- Choose from hundreds of movies right from your TV
- Pick from new releases, old favorites, children's videos, and more. On Demand will deliver the movie right to your TV.
- Easily find movie titles, and get detailed program information.
- On Demand movies are in digital quality picture and sound.
- Start them whenever you want
- Pause, fast-forward and rewind – without a VCR
- Watch them again and again for 24 hours
- Free access with Cox Digital Cable
- Unlimited access to HBO On Demand, Cinemax On Demand, and STARZ! On Demand when you subscribe to the corresponding premium channel.

You decide what's on TV

Since you have Cox Digital Cable, you not only have access to up to 250 channels of great entertainment, you also have hundreds of movie choices with On Demand - including new releases, action-adventure, comedy, drama and more.

Best of all, you get free access with Cox Digital Cable

All you have to do is tune to channel 998 and order your On Demand event today!



On Demand Instructions

1. TO GET STARTED

- Go to channel 998 and select a category.

2. SELECT A PROGRAM

Using the UP/DOWN arrow keys:

- Choose a category and press SELECT.
- Choose a program and press SELECT.
- Synopsis, rating, run time and price will appear.
- Press SELECT on BUY NOW.

Additional fees may apply from the movies On Demand category.

3. CONFIRM YOUR SELECTION

- Press SELECT to VIEW NOW, the program will start automatically.

4. RESUME VIEWING

- From the MAIN MENU choose the previously viewed category (i.e. HBO On Demand).
- Select RESUME VIEWING
- Choose the title to resume viewing and press SELECT.
- To begin where you left off, press the UP arrow on your remote.

5. TO EXIT

- Press the EXIT button on your remote.
- Press GUIDE, then select your new channel.

REMOTE FUNCTIONS

PLAY - Up Arrow
STOP - Down Arrow
FAST FORWARD - Right Arrow
REWIND - Left Arrow
PAUSE - Select Button

Requiring the PIN for purchasing

You can specify whether you want PPV purchasing restricted by the PIN. If you choose to require the PIN, household members must enter the PIN before they can purchase a program. It does not matter whether Parental Control is on or off. If you do not require a PIN, anyone can purchase programs.

To require the PIN for purchasing

1. Press the **MENU** button. The Settings Menu appears.
2. Press the **UP** or **DOWN** arrow to highlight the Parental Control preference.

Purchasing Cox iN DEMAND

The Cox Interactive Program Guide_{sm} gives you the flexibility to purchase Cox iN DEMAND Pay-Per-View (PPV) programs in two different ways:

- Purchase PPV programs by channel
- Purchase future programs from the Program Guide

Purchasing programs from Cox iN DEMAND (Pay-Per-View) channels

You can purchase programs directly from PPV channels. An example of a PPV channel is shown below.

Channel 501	
Pay Per View	
Crocodile Dundee in Los Angeles	
5:30 pm - 7:30 pm	
The Aussie adventurer mixes it up with smugglers in L.A.	
Crocodile Dundee in Los Angeles. Starring paul hoga, Linda Kozlowski. Directed by Simon Wincer. From USA/Australia. 2001.	
92 min. Rated PG: Violence. Adult Language. Program Type: Movie/Comedy. ** . Surround Sound. [CC] [SAP] ↵	
Buy until 5:47 pm	\$3.95
[MENU] Purchase Review	[SELECT] Buy

To purchase PPV programs by channel

1. While watching TV, press **PPV**.
2. Press **GUIDE**, PPV listings appear.
3. Press **DOWN**, **UP** or **RIGHT** to highlight the PPV program you want to purchase.
4. Press **SELECT** to choose the highlighted program.

Note: You can order a movie until 15 minutes after the start time, then the next start time will appear. If it is past the ordering window, the next movie on this channel will automatically be selected. You will need to verify that the next movie is one you want to purchase.

Purchasing Cox iN DEMAND

5. Press **SELECT** to purchase the program. (If you enabled the PIN for purchasing, a screen appears asking you for your PIN. Enter your four-digit PIN.)
6. Press **SELECT** again to confirm your purchase. You are now confirmed for the purchase and will automatically tune to the purchased program when it becomes available.

Purchasing future Cox iN DEMAND Pay-Per-View (PPV) programs from the Program Guide

1. Press the **GUIDE** button. The Program Guide displays. The current program is highlighted in the time grid.
2. Press the **UP**, **DOWN** or **RIGHT** arrow button to highlight the future PPV program you want to purchase.
3. Press the **SELECT** button. You see a screen asking you to buy the PPV program.
4. Press the **SELECT** button to purchase the program. (If you enabled the PIN for purchasing, a screen appears asking you for your PIN. Enter your four-digit PIN).
5. Press the **SELECT** button again to confirm your purchase. You are now confirmed for the purchase and will automatically tune to the purchased program when it becomes available.

**Note: If you have purchased a PPV program, you must cancel it before the start time if you don't want to be charged. See page 36 for how to cancel a PPV.*

Requiring the PIN for purchasing

You can specify whether you want PPV purchasing restricted by the PIN. If you choose to require the PIN, household members must enter the PIN before they can purchase a program. It does not matter whether Parental Control is on or off. If you do not require a PIN, anyone can purchase programs.

To require the PIN for purchasing

1. Press the **MENU** button. The Settings Menu appears.
2. Press the **UP** or **DOWN** arrow to highlight the Parental Control preference.

Purchasing Cox iN DEMAND

3. Press the **RIGHT** arrow button. The following message appears:

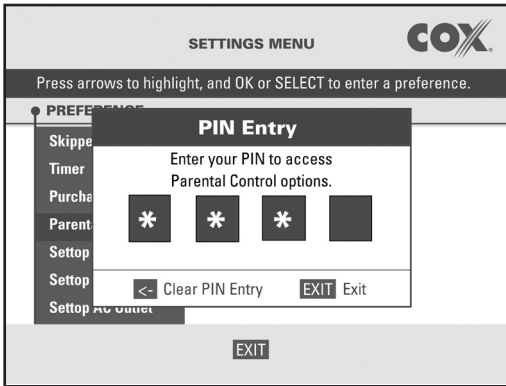

4. Press the numbered buttons to enter the four numbers of your PIN. You now see the Option column.
5. Press the **UP** or **DOWN** arrow button to highlight the Purchasing option.
6. Press the **RIGHT** arrow button to move to the Setting column.

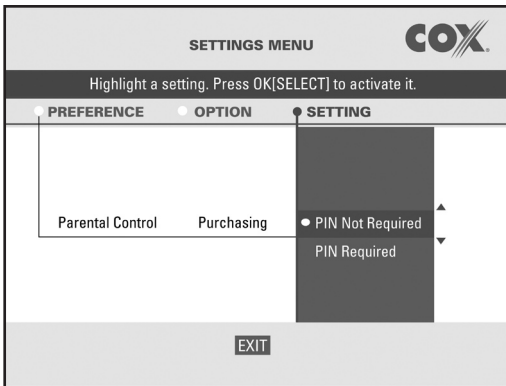

7. Press the **UP** or **DOWN** arrow button to highlight the PIN Required option.
8. Press the **SELECT** button. Household members now must enter the PIN before they can purchase a program.
9. To exit the Settings Menu, press the **EXIT** button.

Purchasing Cox IN DEMAND

Canceling purchases

You can cancel a purchased program when the program has not started yet and when the purchase allows cancellation.

To cancel purchases

1. Press the menu button. The settings menu displays.
2. Press the **UP** or **DOWN** arrow button to highlight the Purchase Review preference.
3. Press the **RIGHT** arrow button. A list, similar to the one below, appears showing your PPV purchases.

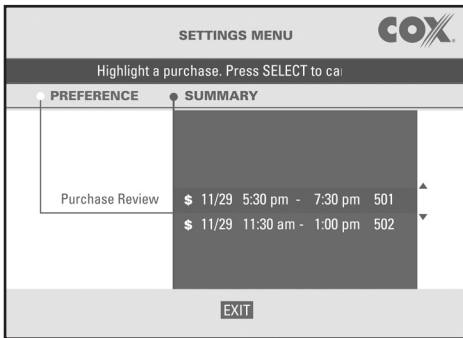

4. Press the **UP** or **DOWN** arrow button to highlight the program you want to cancel.

The status bar at the top shows whether you can cancel a purchase.

Purchasing Cox iN DEMAND

5. Press the **SELECT** button to cancel the purchase. The following screen appears:

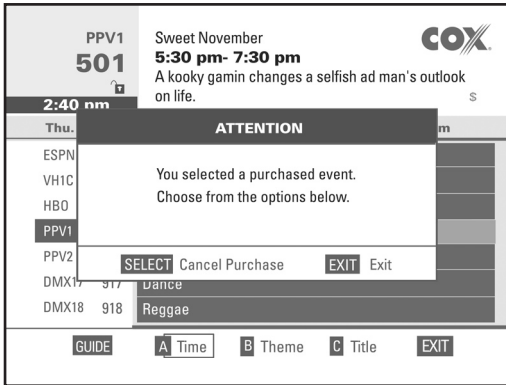

*Note: You may get a message that you cannot cancel the purchase. Press the **SELECT** button to accept the message.*

6. Press the **SELECT** button to cancel the purchase. You return to the Settings menu.

Troubleshooting

The following list includes common situations that might prevent the full enjoyment of your Cox Digital Cable. If you're still experiencing difficulties after trying these remedies, please call Cox Customer Service at the number provided at the front of this guide.

Damage that requires service

If your equipment has damage that requires service, unplug your equipment from the electrical outlet. Call Cox Customer Service when any of the following occurs:

- There is damage to the power cord or plug.
- Liquid enters the equipment.
- A heavy object falls on the equipment.
- There is exposure to rain or water.
- Operation is not normal (instructions in this book describe the proper operation).
- If the equipment is dropped, or if the cabinet of this equipment is damaged.
- If this equipment exhibits a distinct change in performance.

To schedule a repair appointment, contact Cox Customer Service at the number provided at the front of this guide.

No picture/distorted picture

- Plug your television and the settop into an electrical outlet.
- Make sure all cables are properly connected, and that all connections are tight.
- Make sure the TV power is turned on.
- If your system includes a VCR and/or stereo, make sure they are properly connected to the settop.
- Make sure your TV is tuned to the proper input channel (3 or 4).
- Make sure Parental Control is OFF. See page 27.

Troubleshooting

TV will not turn on when TV is plugged into settop.

If you have selected **AC OUTLET: OFF**, your television will not come on until the setting is changed in the preferences section of the Settings Menu. To access your television, you must:

- Unplug your television from the receiver.
- Plug your television into a wall outlet and, using the power button on the television controls, turn the power ON.
- Using your Cox Digital Remote, press **MENU** to return to the Settings Menu.
- Use the right arrow button to highlight AC Outlet.
- Use the up and down arrow buttons and select **ON WITH receiver**. Press **SELECT**, then press **EXIT**.
- Turn the receiver OFF and plug the TV into the receiver.
- Press the **CABLE** or **TV** button, then the **POWER** button, to turn your television ON and OFF.
- Be sure your television is tuned to channel 3 or 4, and that the receiver is on by checking the power light on the right side of your receiver screen. If the cable box is not on, press **CABLE** or **TV** and then press **POWER** to turn on the receiver.

No sound

- Properly plug your television and receiver into an electrical outlet.
- Verify that the **MUTE** button is not in use.
- Make sure all cables are properly connected.
- Make sure the TV power is turned ON.
- Your equipment includes a VCR and may include a stereo. Make sure they are properly connected to the receiver.
- Make sure your TV is tuned to the proper output channel (3 or 4).
- Make sure the volume is turned up.
- If the problem is with channels below 100, check the SAP setting on your television, referring to the handbook provided by the manufacturer of your TV.
- For channels above 100, check the Language Preference setting in the Settings Menu.

Troubleshooting

No color

- Make sure the current TV program is broadcast in color.
- Adjust the color controls on your television.

Remote control does not work

- Verify that the batteries are working by pressing the power button to see if the red light at the top of the remote turns on. If it does not, replace the batteries.
- Point the remote control directly at the receiver when changing channels.
- Make sure you properly programmed the remote control, refer to the guide you received with your remote.
- If you purchased new equipment, refer to the guide you received from the manufacturer to re-program your remote.

Settop does not power on

- Make sure the receiver is properly plugged into an electrical outlet.
- Make sure all cables are properly connected.
- If the electrical outlet is controlled by a wall switch, make sure the switch is in the ON position.

Connecting the DCT

Audio/Video Connections

Before you begin to hook up your DCT, review the following:

- For basic cable connections, use 75-ohm coaxial cables equipped with F-type connectors. You can find coaxial cables in your local electronics store.
- For audio or video outputs, use cables equipped with RCA and S-Video type connectors.
- If you are connecting the coaxial TO TV/VCR connector on the DCT to the coaxial CABLE / ANTENNA IN connector on the TV, you must tune your TV to channel 3 or 4.
- Disconnect power from the DCT before connecting or changing cable connections.
- Do not place anything on top of the DCT, especially other home video components.

Connecting the DCT

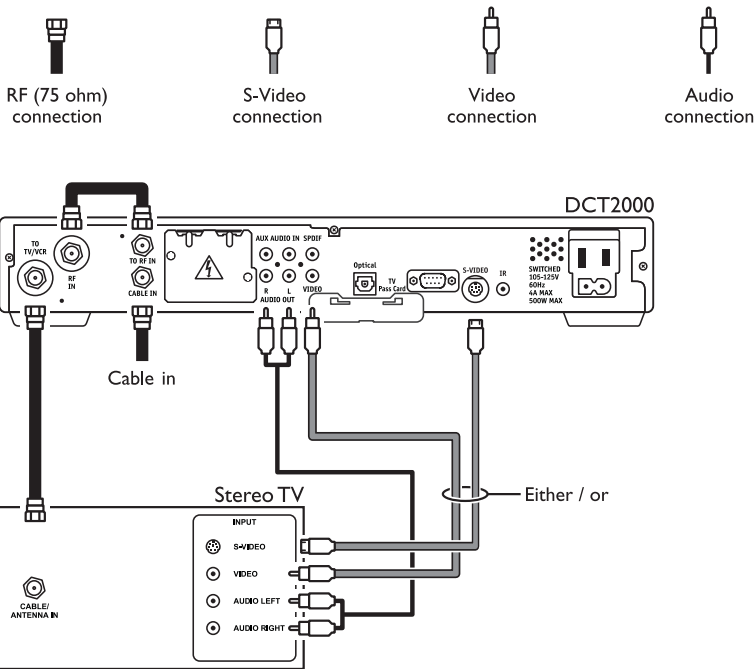





Connecting a Stereo TV:

1. Connect an RF coaxial cable between the cable wall outlet and the CABLE IN connector on the DCT.
2. Connect the RF coaxial cable, supplied with the DCT, between the RF IN and TO RF IN connectors on the DCT.
3. Connect a RF coaxial cable between the TO TV / VCR connector on the DCT and the CABLE / ANTENNA IN connector on the TV.
4. Connect a stereo audio cable between the AUDIO R and L connectors on the DCT and the AUDIO LEFT and AUDIO RIGHT connectors on the stereo TV.
5. Connect a video cable between the VIDEO connector on the DCT and the VIDEO connector on the TV.
OR Connect a S-video cable between the S-VIDEO connector on the DCT and the S-VIDEO connector on the stereo TV.

Connecting the DCT

Connecting Your DCT

-  RF (75 ohm) connection
-  S-Video connection
-  Video connection
-  Audio connection

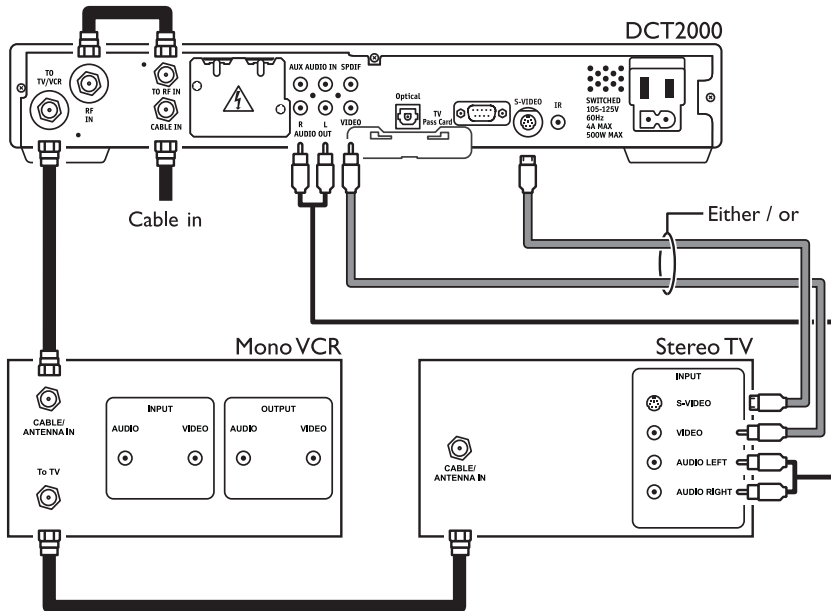

Connecting the DCT

Connecting a Stereo TV and Mono VCR

1. Connect an RF coaxial cable between the cable wall outlet and the CABLE IN connector on the DCT.
2. Connect the RF coaxial cable, supplied with the DCT, between the RF IN and TO RF IN connectors on the DCT.
3. Connect a RF coaxial cable between the TO TV / VCR connector on the DCT and the CABLE / ANTENNA IN connector on the mono VCR.
4. Connect a RF coaxial cable between the To TV connector on the mono VCR and the CABLE / ANTENNA IN connector on the stereo TV.
5. Connect a stereo audio cable between the AUDIO OUT R and L connectors on the DCT and the INPUT AUDIO RIGHT and LEFT connectors on the stereo TV.
6. Connect a video cable between the VIDEO connector on the DCT and the INPUT VIDEO connector on the stereo TV.
OR Connect a S-video cable between the S-VIDEO connector on the DCT and the INPUT S-VIDEO connector on the stereo TV.

Connecting the DCT

Connecting Your DCT

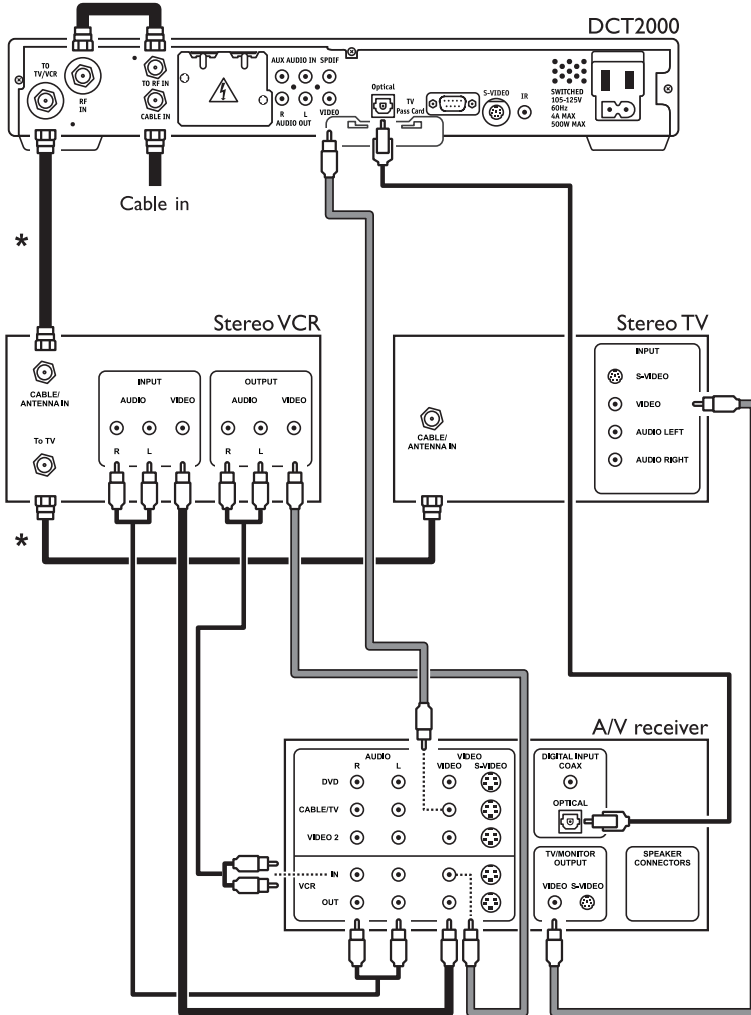

Connecting the DCT

Connecting Dolby® 5.1, TV, VCR and A/V Receiver

1. Connect an RF cable between the cable wall outlet and the CABLE IN connector on the DCT.
2. Connect the RF coaxial cable, supplied with the DCT, between the RF IN and TO RF IN connectors on the DCT.
3. Connect an optical audio cable between the OPTICAL connector on the DCT2000 and the OPTICAL connector on the A / V receiver.
4. Connect a stereo audio cable between the VCR AUDIO OUT R and L connectors on the A / V receiver and the INPUT AUDIO R and L connectors on the stereo VCR.
5. Connect a video cable between the VIDEO connector on the DCT and the CABLE / TV VIDEO connector on the A / V receiver.
6. Connect a stereo audio cable between the OUTPUT AUDIO R and L connectors on the stereo VCR and the AUDIO VCR IN R and L connectors on the A/V receiver.
7. Connect a video cable between the INPUT VIDEO connector on the stereo VCR and the VIDEO VCR OUT connector on the A / V receiver.
8. Connect a video cable between the OUTPUT VIDEO connector on the stereo VCR and the VIDEO VCR IN connector on the A / V receiver.
9. Connect a video cable between the INPUT VIDEO connector on the stereo TV and the TV / MONITOR OUTPUT VIDEO connector on the A / V receiver.

Cable connections marked with an * are optional. These connections allow the use of the DCT and TV without powering-on the VCR and A/V Receiver.

The optional connections are:

- Connect a RF coaxial cable between the TO TV / VCR connector on the DCT and the CABLE / ANTENNA IN connector on the stereo VCR.
- Connect a RF coaxial cable between the To TV connector on the stereo VCR and the CABLE / ANTENNA IN connector on the stereo TV.

When using the Dolby® 5.1 optical output, the SPDIF and left / right baseband audio connections to the A / V receiver are not used.

Notices

Copyright © 2005 by Cox Communications, Inc.

Printed in the United States of America. All rights reserved. No parts of this publication shall be reproduced, stored in a retrieval system, or transmitted by any means, electronic, mechanical, photocopy, recording, or otherwise, without the written permission from the publisher.

Cox Communications, Inc. assumes no liability nor responsibility for the use of any content, materials, or techniques included in this book.

Trademarks, brand names and products mentioned in this book are the property of their respective owners. All such references are used strictly in an editorial fashion with no intent to convey any affiliation with the name or the product's rightful owner.

The Cox Interactive Program Guide is a customized version of the Pioneer PASSPORT DCT. Pioneer and the Pioneer logo are registered trademarks of the Pioneer Electronic Corporation. PASSPORT DCT and the PASSPORT DCT logo are trademarks of Pioneer Digital Technologies, Inc. All other product names mentioned in this publication are trademarks of their respective owners.

Cox is a registered trademark of Cox Communications, Inc.

Free Manuals Download Website

<http://myh66.com>

<http://usermanuals.us>

<http://www.somanuals.com>

<http://www.4manuals.cc>

<http://www.manual-lib.com>

<http://www.404manual.com>

<http://www.luxmanual.com>

<http://aubethermostatmanual.com>

Golf course search by state

<http://golfingnear.com>

Email search by domain

<http://emailbydomain.com>

Auto manuals search

<http://auto.somanuals.com>

TV manuals search

<http://tv.somanuals.com>