

**RAMPAGE**  
BY AUDIOVOX™

**OWNER'S MANUAL  
AND  
INSTALLATION GUIDE**

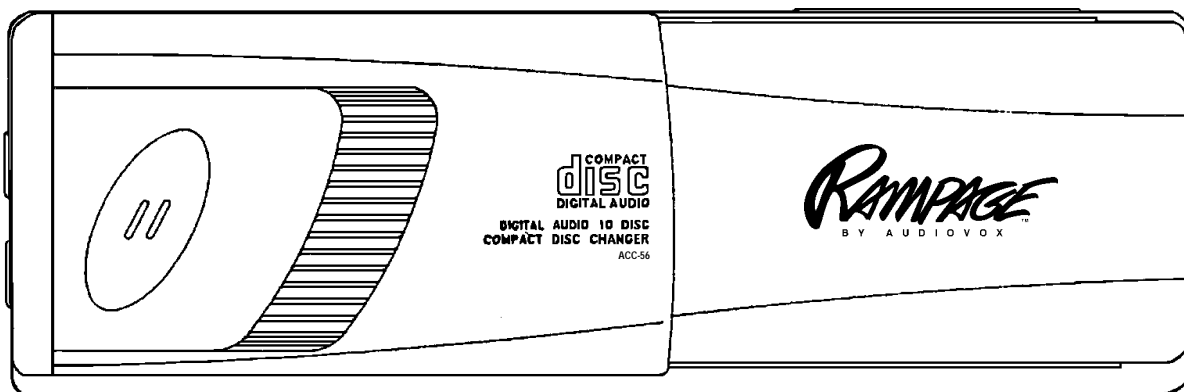

**MODEL ACC-56  
REMOTE-CONTROL  
RF MODULATED  
10-DISC CD CHANGER**



# INTRODUCTION

Congratulations on your purchase of the *RAMPAGE ACC-56 REMOTE-CONTROL 10-DISC CD CHANGER*. This system allows you to easily upgrade your vehicles existing audio system to include a quality CD entertainment function. Once installed, this system utilizes an unused FM frequency on the vehicles existing audio system to play audio through the vehicles existing stereo speaker system - there's nothing else to add or replace. Best of all, the CD Changer is easy to install. There are only three wires to connect and four simple plug-in cables. Just follow the simple step-by-step instructions that follow.

# FEATURES

- Remote mount changer holds up to 10 compact discs
- Remote control with backlit LCD panel, displays disc number, track number and function
- Remote controls include forward and reverse track and disc search, track and disc scan, shuffle and repeat play plus high speed audible cue and review search
- Advanced technology includes 8x oversampling digital filter and twin 1-bit digital/analog converters
- The special design allows horizontal, vertical or 45-degree mounting.

# TOLL-FREE ASSISTANCE

The installation and connections are so simple we doubt you'll need our help, but if you do, we're here to help you. Just call our toll-free assistance line at **1-800-645-4994** during the days/hours shown.

DAY	TIME ZONE			
	PACIFIC	MOUNTAIN	CENTRAL	EASTERN
MON. - FRI.	5:30AM - 4PM	6:30AM - 5PM	7:30AM - 6PM	8:30AM - 7PM
SATURDAY	6AM - 2PM	7AM - 3PM	8AM - 4PM	9AM - 5PM

# INDEX

Introduction and Contents	Page 2	Mounting the Remote Control	Page 12
Packing List	Page 3	Remote Control Operating Instructions	Page 13
Before Installing the Unit	Page 4	Hints for Correct and Safe Operation	Page 15
Where to Install the Changer	Page 5	Handling the Discs	Page 15
Installation	Page 6	Use of the CD Magazine	Page 16
Overall Wiring View	Page 9	CD Changer Operating Instructions	Page 17
Wiring the CD Changer	Page 10	Specifications	Page 17
Wiring the FM Modulator	Page 10	Troubleshooting	Page 18

# PACKING LIST

## MAIN UNIT

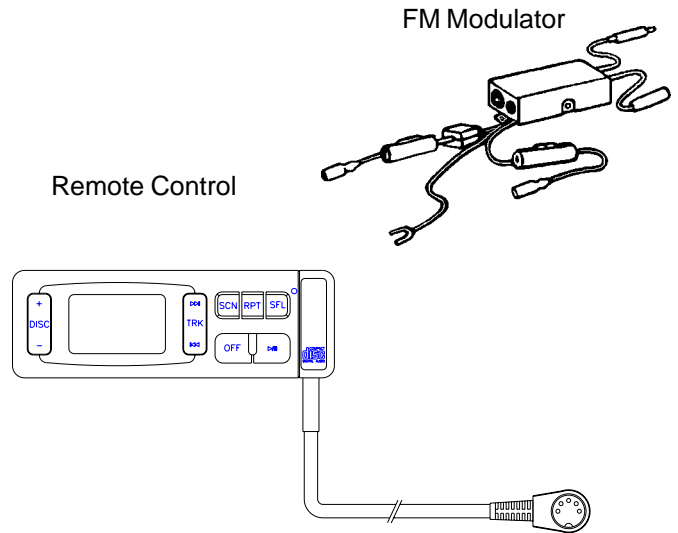
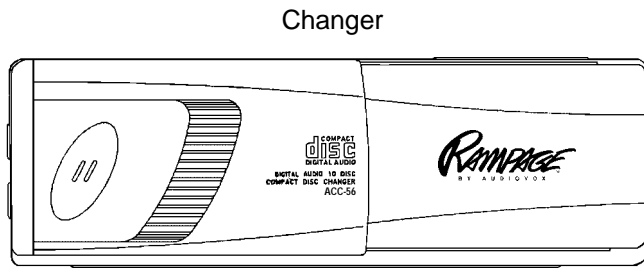

## INSTALLATION PARTS

Bracket (L)

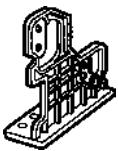

1 pc.

Bracket (R)

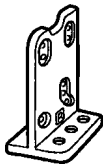

1 pc.

Hexagonal bolt with washer  
(M5 x 10)



7 pcs.

Screw (C)  
Phillips Head Self-Tapping  
Screw  
(M3x12)



2 pcs.

5 Meter Din Cable

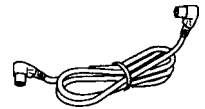

1 pc.

Self-tapping screw  
(M5 x 12)



4 pcs.

Seals (A)

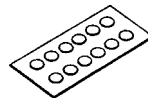

1 pc.

Seals (B)

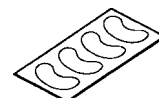

1 pc.

## OTHER ACCESSORIES

CD Magazine (P/N ACC-56MAZ)

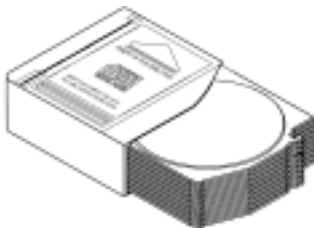

1 pc.

Index label sheet

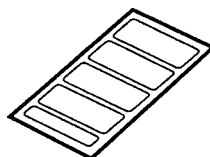

1 pc.

Owner's Manual  
and Installation Guide

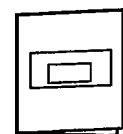

1 pc.

# BEFORE INSTALLING THE UNIT

## Transport Lock Screws

The mechanism in the CD changer is "locked" into place during shipment by three transport lock screws. Be sure to remove the screws prior to installation.

### ● Caution ●

After removing the transport lock screws, place the supplied seals (A) over the screw holes. These seals are used to keep dust out of the unit, which could cause a malfunction.

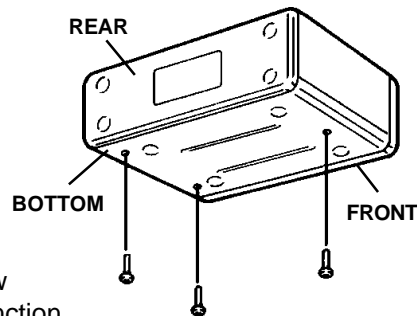

TRANSPORT LOCK SCREWS  
(2 RIGHT SIDE, 1 LEFT SIDE)

## Installation and Wiring Precautions

- 1 To prevent a short-circuit,
  - Be sure to turn off the ignition and remove the negative (-) battery cable, prior to installation.
  - Connect power wires last.

**NOTE:** If the changer is to be installed in a car that is equipped with an on-board drive or navigation computer, do not disconnect the battery cable. If the cable is disconnected, the computer memory may be lost. Under these conditions, use extra caution during installation not to cause a short circuit.

- 2 Do not install the unit in the following locations.
  - Locations exposed to direct sunlight.
  - Where hot air is discharged from the car heater.
  - In areas subject to extreme temperatures.



- 3 Incorrect installation can cause the disc to "skip" when playing. Be sure Mount the unit firmly in place, using the supplied brackets and screws.

- 4
  - Be sure to use the supplied screws.
  - Be careful not to snag any wires when tightening screws.
  - Do not use any of the screws that are part of the brake or steering system, to install the unit.
  - Be careful not to damage the car wiring.

- 5
  - This unit cannot be installed on its side, end, or upside down. Installation in such positions will cause malfunctioning of the mechanism.

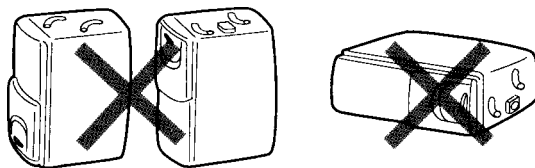

## ADDITIONAL 10-DISC MAGAZINES

Additional CD Magazines are available as an accessory item (Part No. ACC-56MAZ). Visit the store where your ACC-56 was purchased or, contact Audiovox directly for pricing and shipping information (1-800-645-4994). All checks or money orders are to be made payable to Audiovox Electronics Corp. **NOTE:** Never send Cash when ordering.

Audiovox Electronics Corp.  
150 Marcus Blvd.  
Hauppauge, N.Y. 11788  
Attn: *Parts Department*

**NOTE:** New York residents, please include applicable sales tax.

## WHERE TO INSTALL THE CHANGER

A few of the many mounting possibilities are shown below. The following precautions must be considered when selecting the mounting location.

Installation Cautions and Warnings:

1. Fuel Tank - **WARNING!** Never install above your fuel tank as the holes you must drill may pierce the tank or the fuel lines. Also check for other obstructions such as wires, etc.
2. Excessive Heat - Avoid areas exposed to direct sunlight (on top of rear package shelf) or next to your car heater's output ducts.
3. Ease of Use - Make certain the changer is easily accessible for loading and unloading the CD magazine.
4. Distance - The data cable that joins the changer to the FM module is 15 feet long. **Do not** exceed this length.
5. If mounting to a plastic surface, do not use the self-tapping screws provided. Use the bolts and hex nuts provided for a more secure installation.

**IMPORTANT:** Failure to properly secure the CD changer is the most common cause of all "skipping" and related CD play problems. Changer must be mounted as explained on the following pages.

### TRUNK MOUNTING (SEDANS)

This is usually the easiest location to use as there is ample space available. Check that you do not interfere with the removal of your spare tire, etc. Observe caution on fuel tank stated above. The only negative aspect is the need to route the wiring from the trunk to your car dashboard.

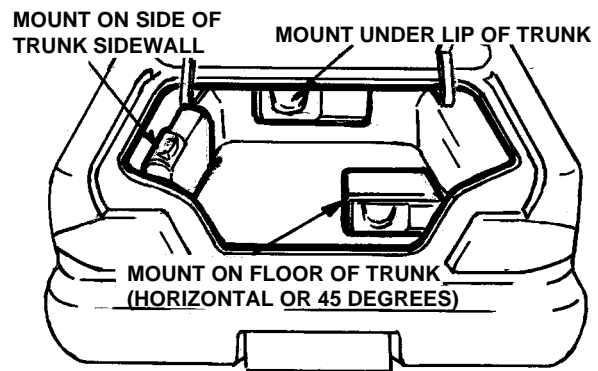

### HATCHBACKS, WAGONS & VANS

A simple investigation of the areas shown will often provide several possibilities. Observe caution on fuel tank stated above and make sure the unit is protected from cargo, passenger entry and exit, etc.

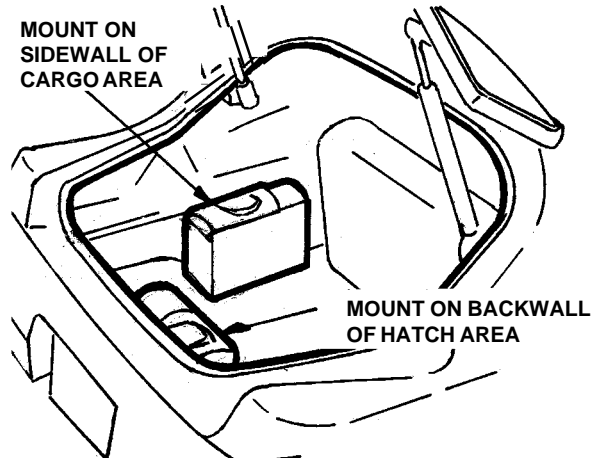

### UNDER PASSENGER'S FRONT SEAT/BEHIND SEAT

If sufficient space and easy access exist, the area under the passenger's front seat is ideal, and will also allow easy wiring access. However, you may need to temporarily remove the seat for ease of installation. The area behind either the passenger's or driver's seat on pickup trucks is another ideal location.

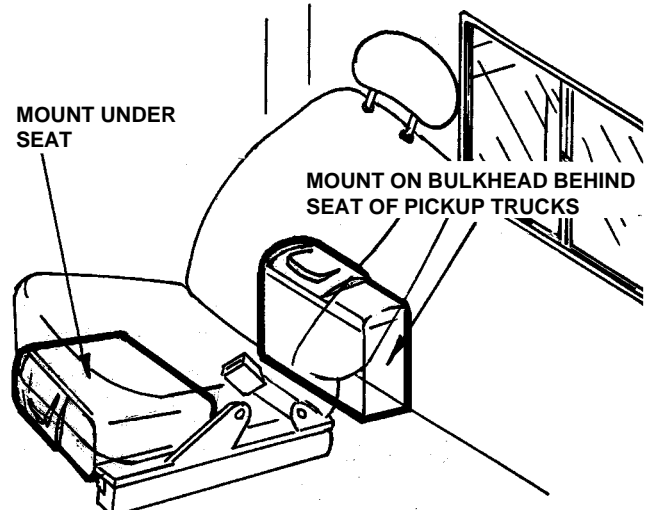

# INSTALLATION

The ACC-56 changer is designed for horizontal (flat), vertical (upright) or 45-degree mounting. It must never be mounted upside-down or on either one of its sides as explained previously. The position of the built-in anti-vibration springs (left and right side), must correspond to the mounting position chosen. If the springs are not set correctly for the type of installation chosen, the anti-vibration compensation will not be effective and vibration may cause the disc to skip.

## CAUTION

After setting the built-in anti-vibration springs, place the supplied Seals (B) over the holes. These seals are used to keep dust, which could cause a malfunction, out of the unit.

### HORIZONTAL INSTALLATION

Set the 4 anti-vibration springs to position "H".

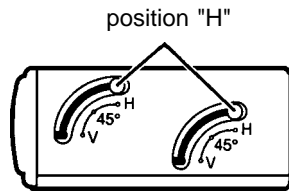

### VERTICAL INSTALLATION

Set the 4 anti-vibration springs to position "V".

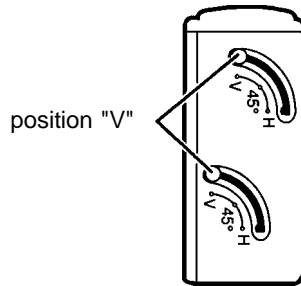

### 45° ANGLE INSTALLATION

Set the 4 anti-vibration springs to position "45°".

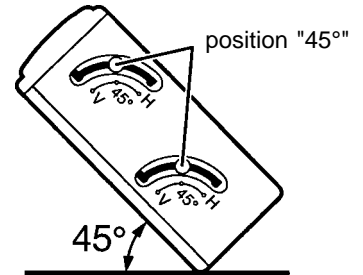

## PROCEDURE FOR HORIZONTAL INSTALLATION

- 1 Attach bracket (L) and bracket (R) to each side of the unit, using the hexagonal bolts with washer base (M5 x 8).

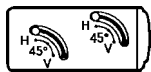

Anti-vibration springs position

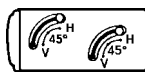

**NOTE:** Use seals (A) to cover unused mounting holes on sides of unit.

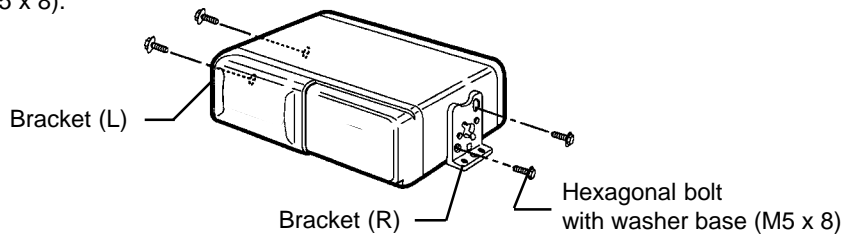

- 2 Determine the mounting location, and drill four mounting holes.

Never mount the unit near the fuel tank.

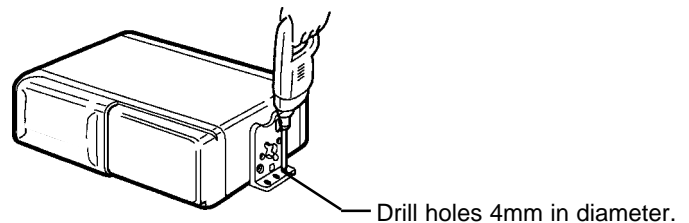

- 3 Secure the unit in place, using four self-tapping screws (M5 x 12). Use RTV (silicone sealer) on screw threads or around the holes to prevent moisture intrusion.

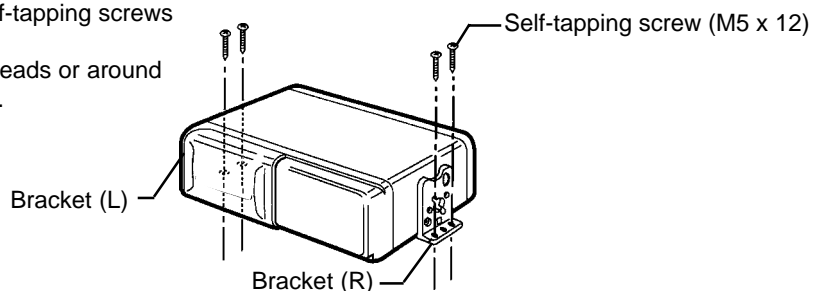

# PROCEDURE FOR VERTICAL INSTALLATION

**NOTE:**

If the anti-vibration spring position has been changed and verified for vertical mounting (as shown on page 6), start with step 2.

**1** Set the 4 anti-vibration springs to position "V".

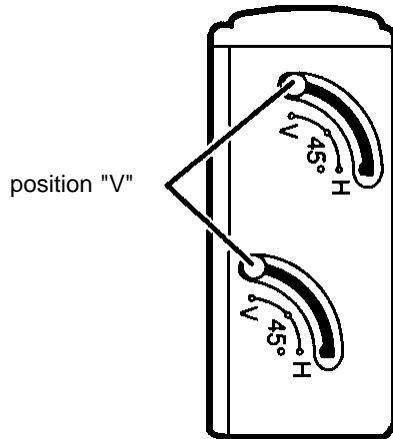

**2** Attach bracket (L) and bracket (R) to each side of the unit, using the hexagonal bolts with washer base (M5 x 8).

**NOTE:** Use seals (A) to cover unused mounting holes on sides of unit.

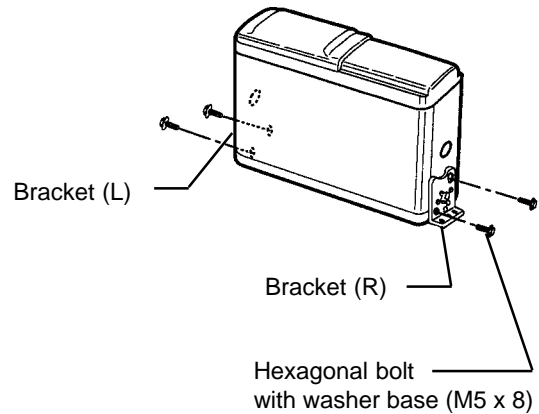

**3** Determine the mounting location, and drill four mounting holes.

Never mount the unit near the fuel tank.

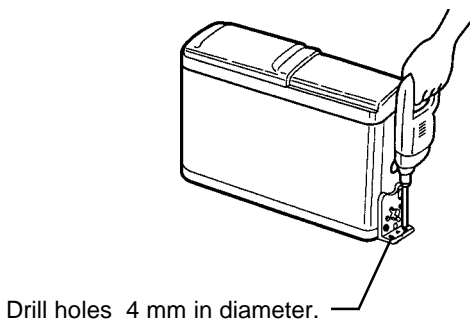

**4** Mount the unit in place, using four self-tapping screws (M5 x 12).

Use RTV (silicone sealer) on screw threads or around the holes to prevent moisture intrusion.

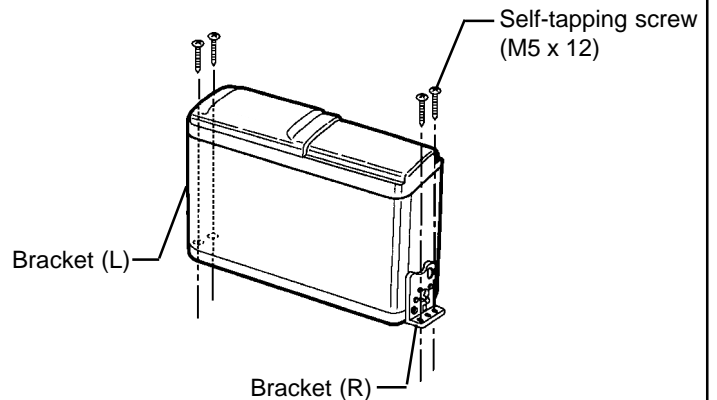

# PROCEDURE FOR 45° ANGLE INSTALLATION

**NOTE:**

If the anti-vibration spring position has been changed and verified for 45° angle mounting (as shown on page 6), start with step 2.

**1** Set the 4 anti-vibration springs to position "45°".

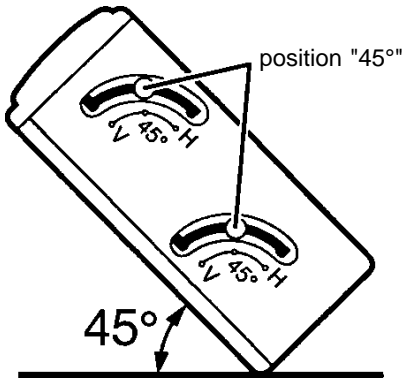

**2** Attach bracket (L) and bracket (R) to each side of the unit, using the hexagonal bolts with washer base (M5 x 8).

**NOTE:** Use seals (A) to cover unused mounting holes on sides of unit.

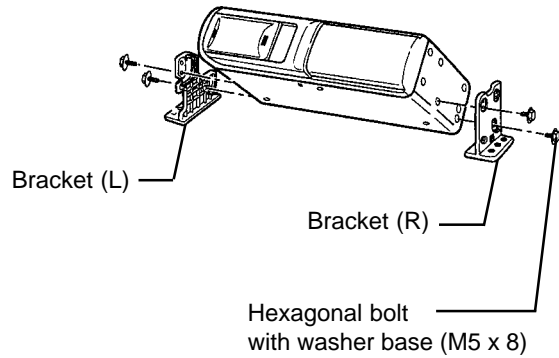

**3** Determine the mounting location, and drill four mounting holes.

Never mount the unit near the fuel tank.

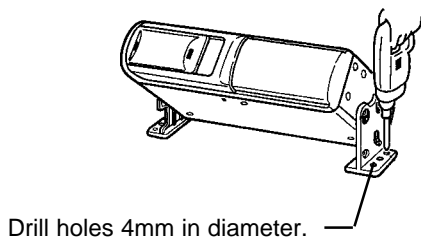

**4** Mount the unit in place, using four self-tapping screws (M5 x 12).

Use RTV (silicone sealer) on screw threads or around the holes to prevent moisture intrusion.

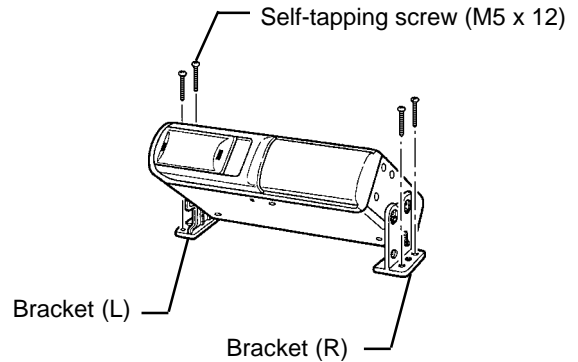



# OVERALL WIRING VIEW

This page is provided to give you a quick look at the entire wiring of the ACC-56. Use it to plan your wire routing paths and possible connection points. Detailed wiring is explained in the following pages.

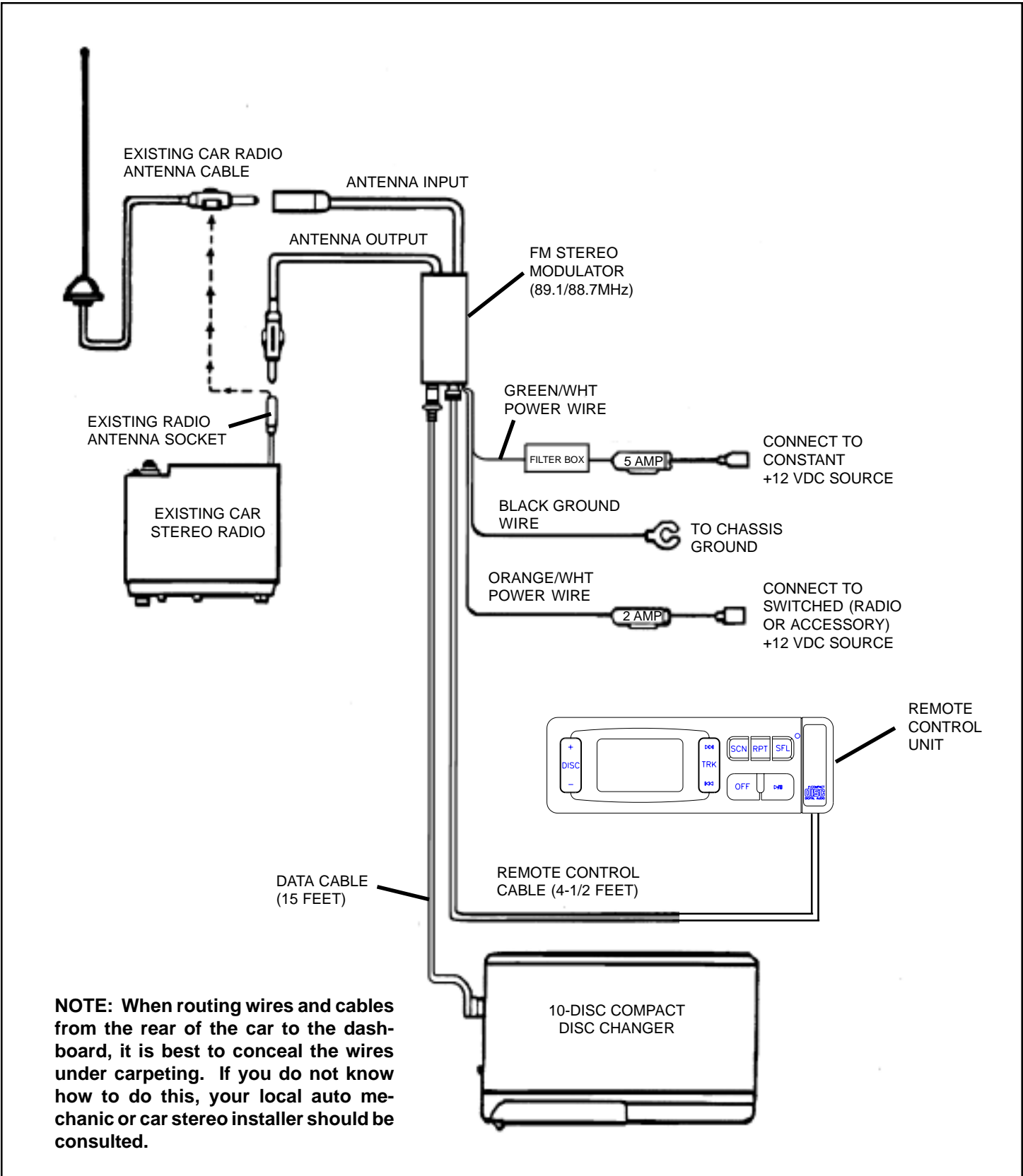

# WIRING THE CD CHANGER

## DATA CABLE

The 15 foot data cable connects the changer to the FM module. First connect the end of the data cable labelled "TO CD CHANGER" to the 8-pin socket on the left side of the changer. Route the other end of the cable up to the car's dashboard area near your existing car radio and plug the data cable into the 8-pin mating socket on the end of the FM modulator.

## WIRING THE FM MODULATOR

The FM modulator should be positioned near your existing car stereo and the 15 foot data cable should be connected to it. Make the following connections to the FM modulator:

### ORANGE WITH WHITE STRIPE WIRE

Attached to the FM modulator is a 3-foot ACC Power wire (orange with white stripe). This is to be connected to a + 12 volt circuit that is only live when the ignition is on. The best connection point is at the car's fuse block at the "RADIO" or "ACCESSORY" identified terminals.

### GREEN WITH WHITE STRIPE POWER WIRE

The 3 foot +12 Constant Power wire (green with white stripe) must be connected to a live 12 volt wire in the vehicle. You will have to check the wire you connect it to and make certain it is always live, even when the car's ignition is turned off. If none is found, route the wire to the car's fuse block and connect it to a live circuit there.

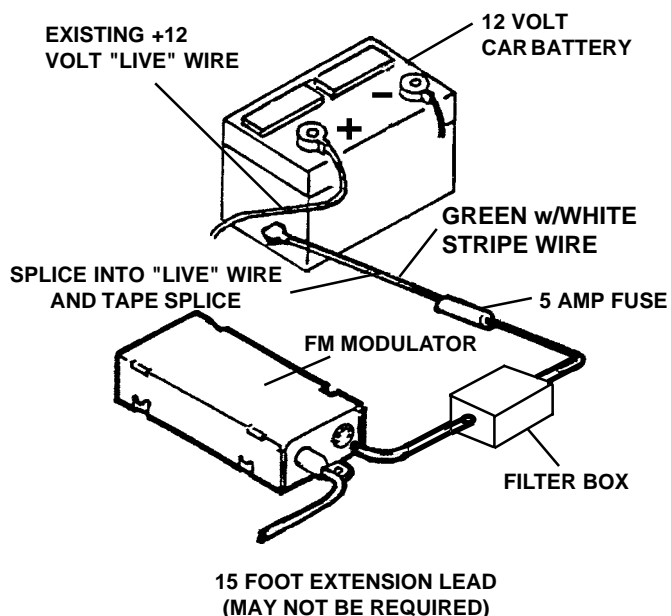
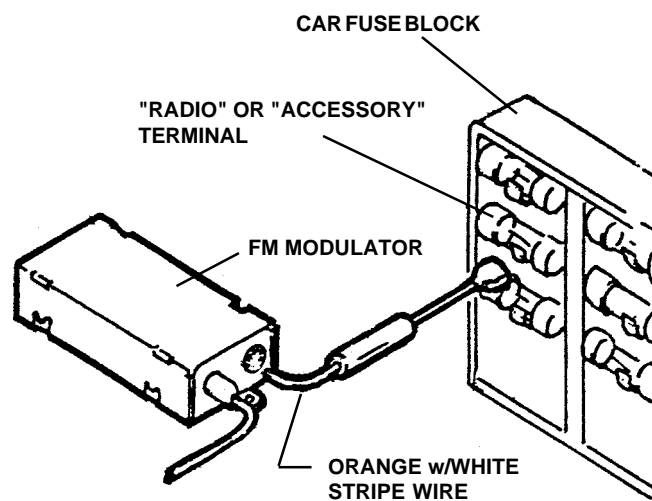
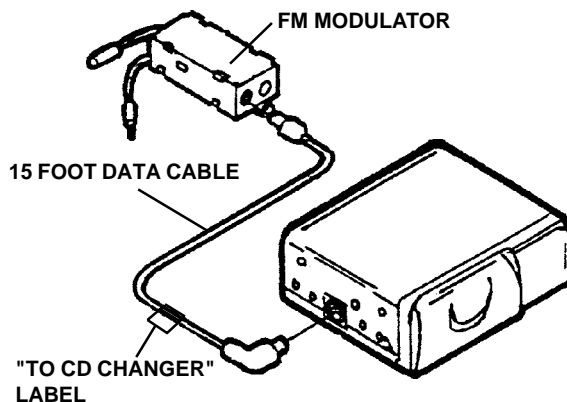

# WIRING THE FM MODULATOR (con't.)

## BLACK GROUND WIRE

The 3 foot Ground wire (black) attached to the FM modulator must be secured to a grounded metal part of the car's chassis. If you cannot find an existing bolt or screw to fasten it to, you must drill a hole in the metal and secure it with a screw. To insure a good ground, remove any paint or grease where the wire will connect.

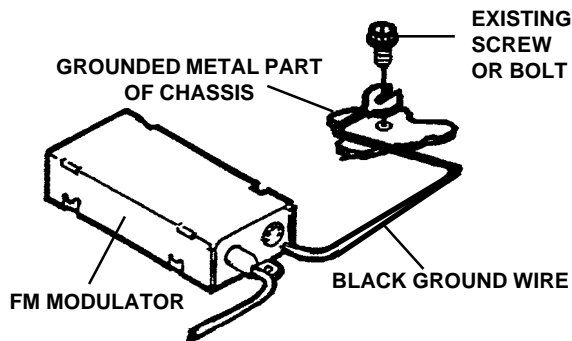

## CAR ANTENNA INPUT

Locate your existing car radio antenna cable. This is normally a black cable about as thick as a pencil and will be plugged into a socket on the rear of your car radio. Unplug this antenna lead and plug it into the mating female socket on the FM modulator.

**IMPORTANT** - Some Import cars have a special dual antenna called "DIVERSITY ANTENNA". If your car has this type of antenna system, you will find the antenna cable will not fit the socket on the FM modulator. Use of the ACC-56 with "DIVERSITY ANTENNA" is not recommended. You may also find some late model GM cars have an antenna plug that is too small to mate with the FM modulator. If this is found, call Audiovox's Toll-Free Assistance for a special adapter (1-800-645-4994). This adapter can also be purchased at any car stereo installation center.

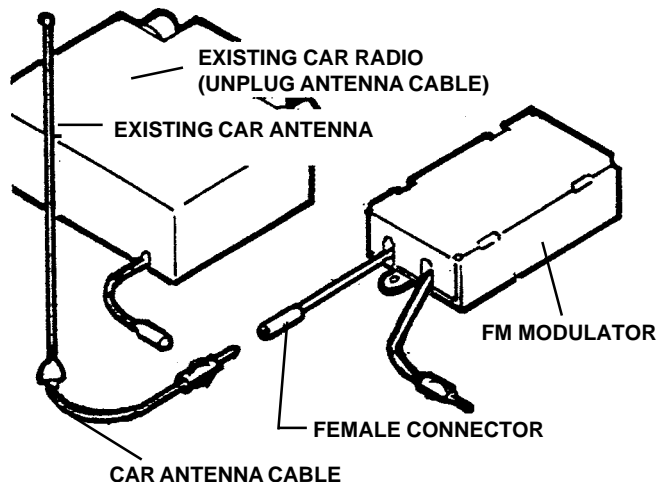

## RADIO ANTENNA OUTPUT

Attached to the FM modulator is a male antenna plug. Simply plug this into the socket on the car radio from which you just removed the car antenna cable.

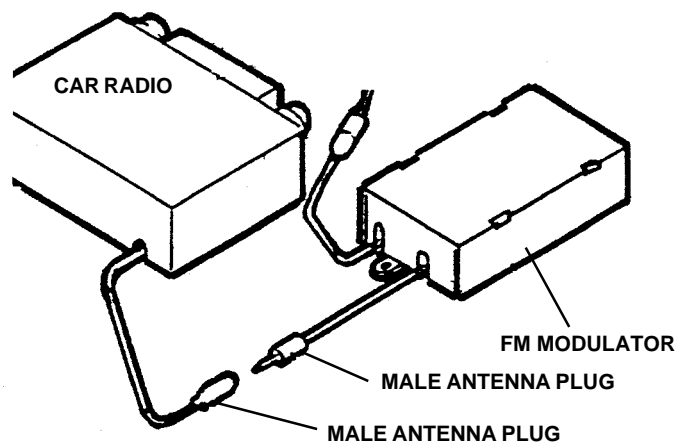

## REMOTE CONTROL CABLE

Attached to your remote control is a cable that plugs into the remaining 5-pin socket on the end of the FM modulator. Position the remote control near the area you will permanently mount it and route the cable to the FM modulator. Plug the cable into the FM modulator.

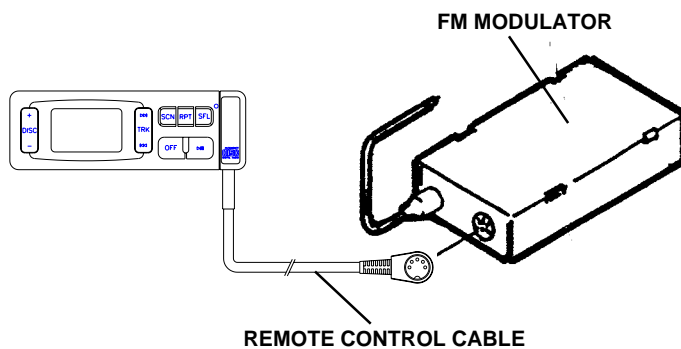

## MOUNTING THE REMOTE CONTROL

On the back of the remote control you will find an adhesive backed "Velcro" pad. Select the desired mounting area on your car dashboard that will allow ease of use and full visibility of the LCD display. Peel off the protective paper on the adhesive pad. Make certain the dash area is clean of all wax, grease, etc., and press the remote control in place. Allow a 1/2 hour for the adhesive to secure, then you will find the Velcro pads will allow you to remove the remote control for hand-held use if desired and replace it as often as needed.

## MOUNTING THE FM MODULATOR

There are two mounting tabs on the FM modulator. It can be secured by two methods. Use two screws "C" and drill two 3/32" holes or use electricians tape or twist ties (not provided).

## ADJUSTMENT OF FM MODULATOR TUNING

To operate your ACC-56, your car radio must be first tuned to the FM band at 89.1MHz. If you find interference on this frequency, you can change the output frequency from the FM module to 88.7 MHz., by moving the slide switch on the FM modulator to the 88.7 MHz. position. You will then have to tune your radio to 88.7 MHz instead of 89.1 MHz, when using your CD changer.

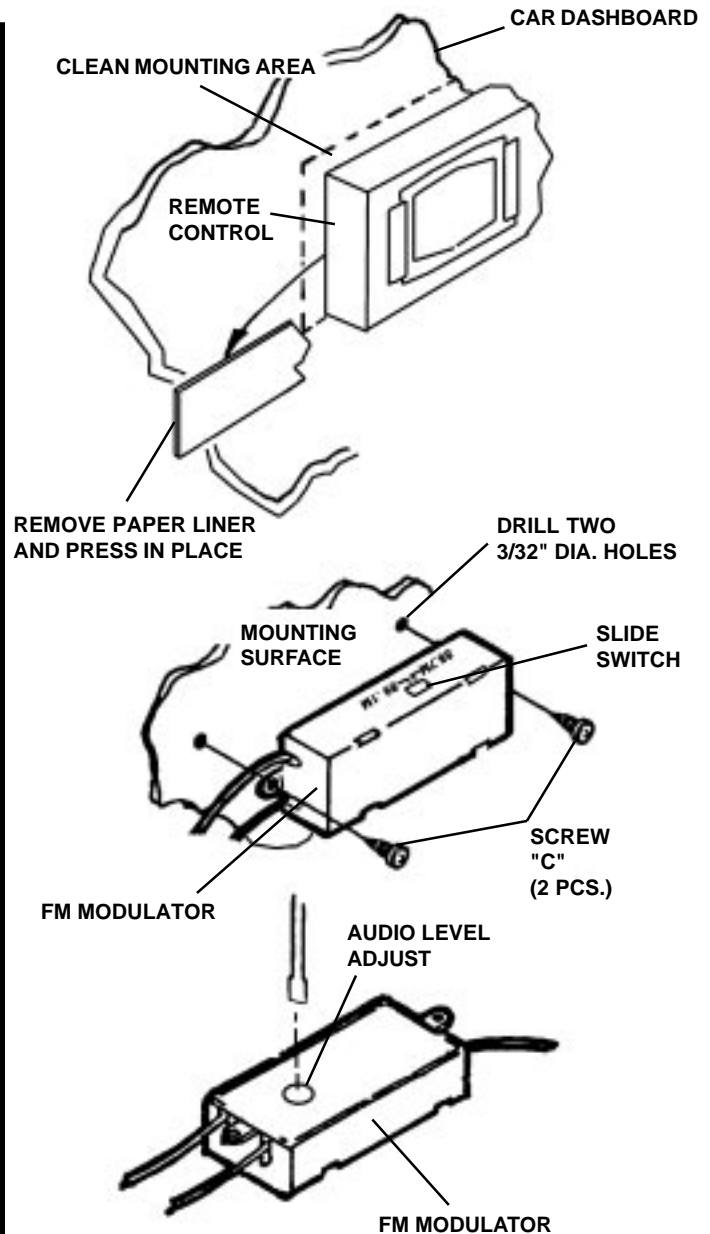

# REMOTE CONTROL OPERATING INSTRUCTIONS

Upon inserting a loaded CD magazine into the changer, the unit will begin automatically checking the magazine for the number of discs loaded and their locations. This will occur even if the vehicle's ignition is turned off. This process will take approximately 45 seconds. During this time, the remote control function will be inoperative.

## CONTROLS

- ① LCD Display
- ② Track/Disc Scan (SCN)
- ③ Track/Disc Repeat (RPT)
- ④ Track/Disc Shuffle (SFL)
- ⑤ Reset Button
- ⑥ Play/Pause (▶/||)
- ⑦ Power Off Switch (OFF)
- ⑧ Track (TRK) Select (◀▶)
- ⑨ Track (TRK) Search (◀▶▶)
- ⑩ Disc Select (+/-)

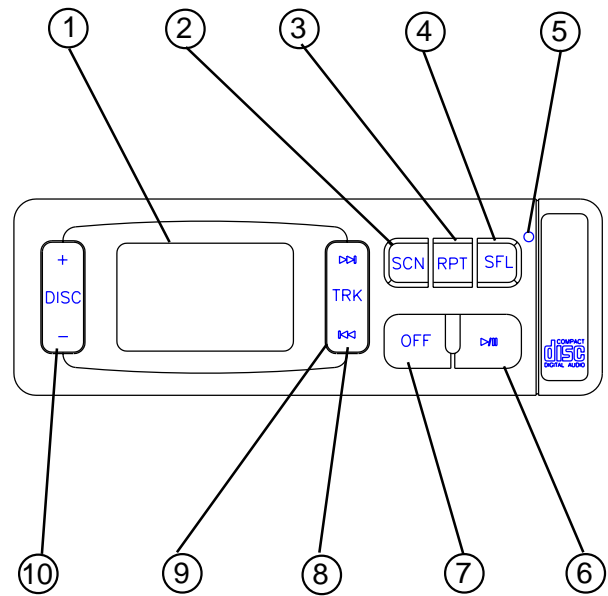

## PREPARING FOR OPERATION

1. Load CD magazine ⑪ and insert into changer as described on page 16.
2. Turn on your car ignition and your car stereo ⑫ and select "FM" band ⑬.
3. Tune to 89.1 on the FM band ⑭ unless you set the selection switch on the FM module to 88.7; then tune to 88.7 on the FM band.

**NOTE:** You may find that it will be easier to use one of your presets specifically for CD operation.

4. Press the Reset button ⑮ on the remote control using a pencil tip or other thin pointed instrument.

**NOTE:** This is only required the First Time you use the Changer.

5. Turn on the CD changer by pressing the Play/Pause button ⑯. The LCD panel ⑰ will illuminate and disc number 1 will begin play.
6. Adjust your car radio's volume, balance and tone controls for desired sound.
7. When the last track on disc 1 has played, the unit will automatically advance to the next disc in sequence and begin playing. This will continue until all discs have been played at which time the unit will begin playing disc number 1 again.

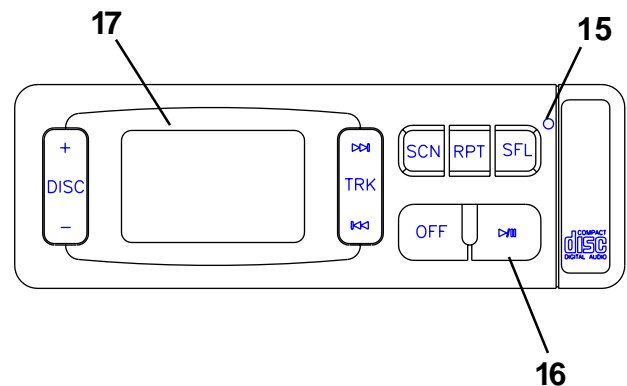
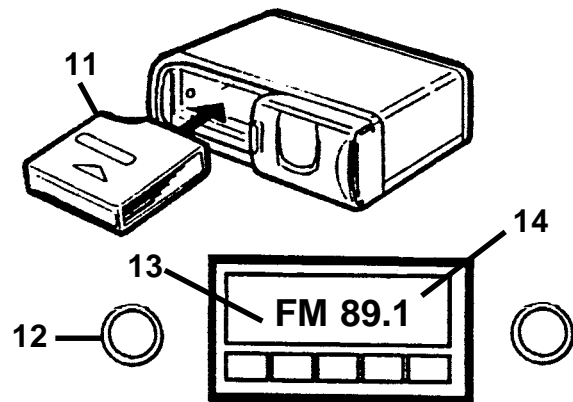

## USE OF CONTROLS

### ① LCD DISPLAY

The LCD Display Panel will illuminate when the CD changer is operating. Different symbols will appear depending on the function and operation in use. Each functional display is explained in the following paragraphs.

### ② TRACK/DISC SCAN (SCN)

When the Scan button is pressed, the indication **SCN** will appear on the LCD panel and the first 10 seconds of each track on the disc will be played in order. When a desired track is reached, press the Scan button again and play of that track will continue (**SCN** will disappear from the display). Scan mode will be cancelled by activating any other function (Repeat, Shuffle, Disc Select, Track Select, or Track Search).

When the Scan button is pressed and held for longer than 2 seconds, the **SCN** and **DISC** indications will appear on the LCD panel and the first 10 seconds of the first track of each disc in the magazine will be played. When a desired disc is reached, press the Scan button again and play of that disc will continue (**SCN** and **DISC** will disappear from the display). Disc Scan mode will also be cancelled by activating any other function (Repeat, Shuffle, Disc Select, Track Select, or Track Search).

### ③ TRACK/DISC REPEAT (RPT)

When the Repeat button is pressed, the indication **RPT** will appear on the LCD panel and play of the selected track will be continuously repeated until the Repeat mode is cancelled by pressing the Repeat button again or by activating the Scan 9 or Shuffle 7 functions.

When the Repeat button is pressed and held longer than 2 seconds, the **RPT** and **DISC** indications will appear on the LCD panel and play of the selected disc will be continually repeated until the Disc Repeat mode is cancelled by pressing the Repeat button again or by activating the Scan 9 or Shuffle 7 functions.

### ④ TRACK/DISC SHUFFLE (SHF)

When the Shuffle button is pressed, the indication **SHF** will appear on the LCD panel and the tracks on the disc will be played in a random, shuffled order. The Track Skip 5 function will also select tracks in the shuffled order instead of the normal progression. The Track Shuffle mode can be cancelled by pressing the Shuffle again, or by activating the Scan 9 or Repeat 8 functions.

When the Shuffle button is pressed and held longer than 2 seconds, the **SHF** and **DISC** indications will appear on the LCD panel and the discs in the magazine will be played in a random shuffled order, as well as the tracks on each disc. When all the tracks on the selected disc have been played, the next disc will be selected in shuffled order and its tracks will be played in shuffled order. The Disc Shuffle mode can be cancelled by pressing the Shuffle button again, or by activating the Scan 9 or Repeat 8 functions.

### ⑤ RESET BUTTON

A reset button is located on the front panel of the remote control which must be activated with a pen or other thin object as it is recessed to prevent accidental engagement. The reset circuitry

is provided to protect the unit's microprocessor and laser pickup system and should only be activated under the following circumstances:

1. Initial installation after all wiring is completed (this must be done).
2. If abnormal disc operation is encountered, the reset button may be pressed to clear the system and return to normal operation.

**IMPORTANT:** Use of the Reset button on the CD Changer will cause the CD magazine to be automatically ejected. Make certain changer door is fully opened prior to using Reset.

### ⑥ PLAY/PAUSE (▶ /||) BUTTON

Pressing this button turns on the CD changer, illuminates the LCD panel and begins play of disc #1 if a new CD magazine has been loaded into the changer. If a magazine was already in the changer, play will resume from the track on the disc previously in play. Play of the disc is shown by the indication ▶ and the rotating disc symbol on the LCD panel. Pressing the button again will temporarily stop play of the disc. The pause indication || will appear on the LCD panel and the disc symbol will stop rotating and flash instead. Press the button again to resume play of the disc.

**NOTE:** If left in the PAUSE mode for 5 minutes, the unit will automatically shut off.

### ⑦ POWER OFF SWITCH (OFF)

Press this switch to turn the CD changer off and return to normal FM reception.

### ⑧ TRACK SELECT (◀◀ ▶▶)

The Track Select function is used to quickly access the beginning of a particular track. Press Forward Track Select (▶▶) or Backward Track Select (◀◀) to locate the desired track as shown by the track number indication on the LCD panel.

### ⑨ TRACK SEARCH (◀◀ ▶▶)

High-speed audible search to any section of the disc can be made by the search functions. Press and hold the ▶▶ button to advance quickly in the forward direction or press and hold the ◀◀ button to advance rapidly in the backward direction. During search operation, the rotation disc symbol will turn faster and the appropriate symbol ◀◀ or ▶▶ will flash on the LCD panel. When the forward search ▶▶ button is held down and end of the last track is reached, or the backward search ◀◀ is held down and the unit reaches the beginning of the first track on the disc, the unit will enter the Pause mode until the button is released.

### ⑩ DISC +/- SELECT BUTTON

Press the DISC select button to select the desired disc for play as shown on the LCD panel. The unit will automatically load the selected disc and begin play. To advance to a higher number disc, press the + side of the button. To return to a lower number, press the - side.

**CAUTION:** When the CD magazine is ejected by the use of the Reset button, whichever disc was in play prior to pressing Reset will be left in the play position in the changer. It is critical that before reinserting the CD magazine, you must **REMOVE ALL DISCS** from it. After you have inserted the empty CD magazine, press EJECT on the changer and the "in play" disc will be loaded into the empty magazine. You may then remove the magazine and reload as many discs as desired.

**WARNING:** Avoid use of Reset button after initial use unless you have a definite abnormal disc operation. Use the EJECT button on the changer to remove the CD magazine for normal operation.

## ***HINTS FOR CORRECT AND SAFE OPERATION***

This CD Changer is designed to be operated only on 12 volt DC negative ground systems. The unit cannot be used on 24 volt or positive ground systems.

### **TEMPERATURE**

The unit may not operate correctly in extremely hot or cold temperatures. It is equipped with a built-in thermal protection circuit which will stop operation of the unit when the temperature reaches the preset level. If this should happen, the unit will resume operation when the vehicle returns to a normal temperature range.

Remove the magazine from the unit when it is not being used during hot weather. If the discs are left in an extremely hot car they may warp. If the CD changer is not used for long periods of time, remove the compact discs from the magazine, and store them in their cases.

### **CONDENSATION**

Moisture can condense on the laser lens of the CD changer during rainy and humid days, or right after the heater is turned on in the car (if the changer is mounted in the passenger compartment). If this should happen the unit will not operate correctly. To remedy the situation, remove the discs from the unit and wait approximately one hour. During this time the moisture will evaporate and the unit will operate normally.

### **INTERRUPTIONS IN SOUND (Skipping)**

The sound from the unit may "skip" and be interrupted if the anti-vibration springs are not set correctly, if the changer is mounted on-end or upside-down, or when travelling on very rough road surfaces. If this should occur, check for errors made during installation or wait for the road surface to improve.

### **3" (8cm) CD-SINGLES**

This unit is not designed to play 3" (8cm) CD-Single discs. Inserting a 3" disc into the magazine, either with or without a 3" disc adaptor, can damage the changer and the disc. Such damage will not be covered by the Warranty on this product.

## ***HANDLING THE DISCS***

Dirt, dust, scratches and warpage cause sound skips during playback and a deterioration of sound quality. To take proper care of your discs:



1. Use compact discs that have the  logo.
2. Fingerprints and dust should be carefully wiped off the disc's signal surface (glossy side) with a soft cloth. Unlike conventional records, the compact disc has no grooves to collect dust and microscopic debris, so gently wiping with a soft cloth should remove most particles. Wipe in a straight motion from the inside to the outside of the disc. Small dust particles or light stains will have absolutely no effect on reproduction quality.
3. Never use such chemicals as record sprays, antistatic sprays or fluids, benzine or thinner to clean compact discs. Such chemicals could irreparably damage the disc's plastic surface.
4. Discs should be put back in their cases after use to avoid serious scratches that could cause the sound to skip.
5. Do not expose discs to direct sunlight, high humidity, or high temperatures for extended periods of time. Long exposure to high temperatures can warp the disc.
6. Do not stick paper, labels, or tape on the disc surface.
7. Do not write with any type of pen, pencil, or marker on the disc surface.
8. To minimize fingerprints and smudges on the signal surface, always try to hold the discs by their outer edge and center hole.

# USE OF THE CD MAGAZINE

## LOADING DISCS INTO THE MAGAZINE

This CD Changer uses a specially-designed magazine to hold up to 10 compact discs. To load discs into the magazine, grip the tab on the magazine tray into which you will be loading a disc and pull it out gently as shown in Figure 1. Pull out only one tray at a time. Insert a disc into the tray with the label side down (play surface facing up) as shown in Figure 2. Push the tray back into the magazine as shown in Figure 3. Load discs into the remaining 9 trays in a similar manner.

## REMOVING DISCS FROM THE MAGAZINE

To remove a disc from the magazine, pull out the tray of the disc to be removed, lift out the disc, and push the tray back into the magazine.

## NOTES:

- Avoid touching the playing side of the disc.
- Only one disc can be inserted into each tray of the magazine. Do not try to insert more than one disc into each tray as damage to the discs and magazine may occur.
- This changer is not designed to play 3" CD-Single discs (8cm). Inserting a 3" disc into the magazine, either with or without a 3" disc adaptor, can damage the changer and the disc. Such damage will not be covered by the Warranty on this product.
- Additional CD magazines are available as accessory item part number **ACC-56MAZ** from your Audiovox dealer, or you may contact us directly at:

## LOADING THE MAGAZINE INTO THE CHANGER

Completely slide the door on the changer to the right as shown in Figure 4. Making sure the top of the magazine is facing upward, gently insert it into the unit until it clicks into place, as shown in Figure 5. Slide the door of the changer fully closed and the unit is ready for operation.

## REMOVING THE MAGAZINE FROM THE CHANGER

The magazine can be removed from the changer using one of two methods as outlined below in steps 1 and 2.

**NOTE:** Be sure to keep the door on the changer closed at all times when not loading or removing the magazine. Leaving the door open could allow dust, dirt and moisture to enter the changer which could cause the unit to malfunction.

1. During normal operation with power applied, slide open the door on the changer and press the eject button as shown in Figure 6. The magazine will eject and can be removed.
2. If the magazine will not eject in a normal manner, remove power by disconnecting the DIN cable from the changer.
  - a. Slide open the magazine door. On the bottom left rear of the changer, as shown in Figure 5, peel off the tape covering the access hole; insert a thin-bladed screwdriver into the access hole and engage the mechanical release arm.
  - b. Lightly leverage the blade to the right and the magazine will disengage and be ejected.

Fig. 1

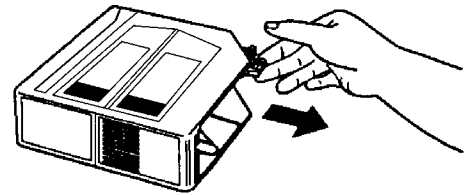

Fig. 2



Fig. 3

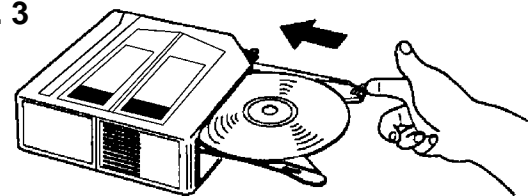

Fig. 4

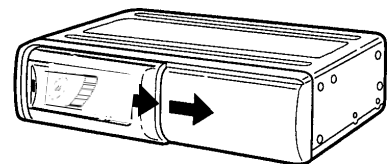

Fig. 5

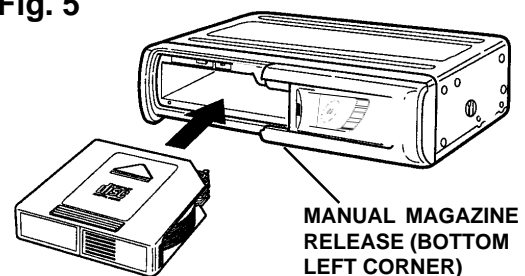
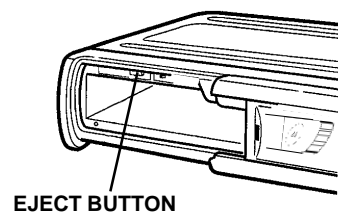

Fig. 6





## **CD CHANGER OPERATING INSTRUCTIONS**

This CD Changer is designed to operate through a compatible Audiovox car stereo which incorporates the controls and display functions or through the FM section of any car stereo. Please check with your Audiovox stereo specialist for recommendations of the models that will work with this changer. The specific operating instructions for the changer will be contained within the Owner's Manual of the compatible unit.

### **SPECIFICATIONS:**

#### **Changer:**

Frequency Response:	5 - 20,000 Hz $\pm$ 1dB
Distortion:	0.008% @ 1kHz
Dynamic Range:	95 dB
Signal-to-Noise Ratio:	95 dB
Channel Separation:	70 dB @ 1kHz
Wow & Flutter:	below measurable limits
Dimensions:	9-5/8" W x 3-3/8" H x 6-7/8" D 245 mm x 85 mm x 174 mm
Operating Voltage:	12 Volts DC, negative ground
Current Drain:	800mA (Playback/loading/ejecting)

#### **FM Modulator:**

Output Frequency: 88.7/89.1 MHz (Switchable)

#### **Accessories Supplied:**

10-disc magazine, P/N ACC-56MAZ  
Mounting hardware (1set)  
Connecting cable (1ea.)

# TROUBLESHOOTING

An error made in operation or during installation of this product may be mistaken for a system malfunction. Please perform the checks described below before contacting your dealer or service facility.

Symptom	Possible Cause	Remedy
No power	Blown fuse	Check fuses in vehicle fuse box and changer system. Replace as necessary with fuse of same type and rating as original. If fuse blows again, consult with service facility.
	Incorrect connection	Check all wiring and correct as necessary.
Magazine cannot be installed	Magazine is inserted in wrong direction.	Insert magazine in proper direction.
CD is not played	Disc is loaded incorrectly in magazine.	Load disc correctly in the magazine.
Noise, skipping, or intermittent sound during playback.	Scratches on disc or warped disc	Check sound on another disc. If sound from second disc is OK, first disc is defective.
	Extremely dirty disc	Clean disc
	Transit screws still in place	Remove the transit screws from sides of the unit.
	Mounting angle adjustment is not correct.	Set the mounting angle adjustment to the correct position as per the installation instructions.

## 12 MONTH LIMITED WARRANTY

AUDIOVOX CORPORATION (the Company) warrants to the original retail purchaser of this product that should this product or any part thereof, under normal use and conditions, be proven defective in material or workmanship within 12 months from the date of original purchase, such defect(s) will be repaired or replaced with new or reconditioned product (at the Company's option) without charge for parts and repair labor.

To obtain repair or replacement within the terms of this Warranty, the product is to be delivered with proof of warranty coverage (e.g. dated bill of sale), specification of defect(s), transportation prepaid, to the warranty center at the address shown below.

This Warranty does not extend to the elimination of car static or motor noise, to correction of antenna problems, to costs incurred for installation, removal, or reinstallation of the product, or damage to tapes, compact discs, speakers, accessories, or vehicle electrical systems.

This Warranty does not apply to any product or part thereof which, in the opinion of the Company, has suffered or been damaged through alteration, improper installation, mishandling, misuse, neglect, accident, or by removal or defacement of the factory serial number/bar code label(s). THE EXTENT OF THE COMPANY'S LIABILITY UNDER THIS WARRANTY IS LIMITED TO THE REPAIR OR REPLACEMENT PROVIDED ABOVE AND, IN NO EVENT, SHALL THE COMPANY'S LIABILITY EXCEED THE PURCHASE PRICE PAID BY PURCHASER FOR THE PRODUCT.

This Warranty is in lieu of all other express warranties or liabilities. ANY IMPLIED WARRANTIES, INCLUDING ANY IMPLIED WARRANTY OF MERCHANTABILITY, SHALL BE LIMITED TO THE DURATION OF THIS WRITTEN WARRANTY. ANY ACTION FOR BREACH OF ANY WARRANTY HEREUNDER INCLUDING ANY IMPLIED WARRANTY OF MERCHANTABILITY MUST BE BROUGHT WITHIN A PERIOD OF 30 MONTHS FROM DATE OF ORIGINAL PURCHASE. IN NO CASE SHALL THE COMPANY BE LIABLE FOR ANY CONSEQUENTIAL OR INCIDENTAL DAMAGES FOR BREACH OF THIS OR ANY OTHER WARRANTY, EXPRESS OR IMPLIED, WHATSOEVER. No person or representative is authorized to assume for the Company any liability other than expressed herein in connection with the sale of this product.

Some states do not allow limitations on how long an implied warranty lasts or the exclusion or limitation of incidental or consequential damage so the above limitations or exclusions may not apply to you. This Warranty gives you specific legal rights and you may also have other rights which vary from state to state.

**U.S.A. :** AUDIOVOX ELECTRONICS CORPORATION, 150 MARCUS BLVD., HAUPPAUGE, NEW YORK 11788  
• 1-800-645-4994

**CANADA:** CALL 1-800-645-4994 FOR LOCATION OF WARRANTY STATION SERVING YOUR AREA

128-4270E

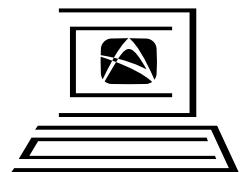

For Customer Service  
Visit Our Website At  
**[www.audiovox.com](http://www.audiovox.com)**  
Product Information, Photos,  
FAQ's, Owner's Manuals

## Free Manuals Download Website

<http://myh66.com>

<http://usermanuals.us>

<http://www.somanuals.com>

<http://www.4manuals.cc>

<http://www.manual-lib.com>

<http://www.404manual.com>

<http://www.luxmanual.com>

<http://aubethermostatmanual.com>

Golf course search by state

<http://golfingnear.com>

Email search by domain

<http://emailbydomain.com>

Auto manuals search

<http://auto.somanuals.com>

TV manuals search

<http://tv.somanuals.com>