



OWNER'S MANUAL AND INSTALLATION GUIDE

AV-455

DETACHABLE FRONT PANEL
ELECTRONICALLY-TUNED AM/FM/MPX RADIO
WITH AUTO-REVERSE CASSETTE PLAYER
AND QUARTZ CLOCK

INSTALLATION INSTRUCTIONS

This unit is designed for installation in cars, trucks, and vans with an existing radio opening. In many cases, a special installation kit will be required to mount the radio to the dashboard. These kits are available at electronics supply stores and car stereo specialist shops. Always check the kit application before purchasing to make sure the kit works with your vehicle. If you need a kit but cannot find it available, call our toll-free "HELP" line at 1-800-645-4994.

UNIVERSAL INSTALLATION PROCEDURE USING MOUNTING SLEEVE

1. Remove the detachable front panel if it is attached to the chassis by pushing the "Release" button. Slide the mounting sleeve off of the chassis. If it is locked into position, use the removal tools (supplied) to disengage it.
2. Check the dashboard opening size by sliding the mounting sleeve into it. If the opening is not large enough, carefully cut or file as necessary until the sleeve easily slides into the opening. Do not force the sleeve into the opening or cause it to bend or bow. Check that there will be sufficient space behind the dashboard for the radio chassis.
3. Locate the series of bend tabs along the top, bottom, and sides of the mounting sleeve. With the sleeve fully inserted into the dashboard opening, bend as many of the tabs outward as necessary so that the sleeve is firmly secured to the dashboard.
4. Place the radio in front of the dashboard opening so that the wiring can be brought through the mounting sleeve. Follow the wiring diagram carefully and make certain all connections of the wiring harness are secure and insulated with wire nuts or electrical tape to insure proper operation of the unit. After completing the wiring connections, attach the front panel and turn the unit on to confirm operation (ignition switch must be "on"). If unit does not operate, re-check all wiring until problem is corrected. Once proper operation is achieved, turn off the ignition switch and proceed with final mounting of the chassis.
5. Carefully slide the radio into the mounting sleeve making sure it is right-side-up until it is fully seated and the spring clips lock it into place.
6. Attach one end of the perforated support strap (supplied) to the screw stud on the rear of the chassis using the hex nut provided. Fasten the other end of the perforated strap to a secure part of the dashboard either above or below the radio using the screw and hex nut provided. Bend the strap to position it as necessary.
CAUTION: The rear of the radio must be supported with the strap to prevent damage to the dashboard from the weight of the radio or improper operation due to vibration.
7. Re-attach the front panel to the chassis and test radio operation by referring to the Operating Instructions for the unit.

INSTALLATION USING KITS

1. If your vehicle requires the use of an installation kit to mount this radio, follow the instructions included with the installation kit to attach the radio to the mounting plate supplied with the kit.
2. Wire and test the radio as described in Step 4 above.
3. Install the radio/mounting plate assembly to the sub-dashboard according to the instructions of the installation kit.
4. Attach the support strap to the radio and dashboard as described in Step 6 above.
5. Replace the dashboard trim panel.

ISO INSTALLATION PROCEDURE

This unit has threaded holes in the chassis side panels which may be used with the original factory mounting brackets of some Toyota, Nissan, Mitsubishi, Isuzu, Hyundai and Honda vehicles to mount the radio to the dashboard. Please consult with your local car stereo specialist shop for assistance on this type of installation.

1. Remove the existing factory radio from its dashboard or center console mounting. Save all hardware and brackets as they will be used to mount the new radio.
2. Carefully un-snap the plastic frame from the front of the new radio chassis. Remove and discard the frame.
3. Remove the factory mounting brackets and hardware from the existing radio and attach them to the new radio.

CAUTION: DO NOT EXCEED M5 X 8 MM MAXIMUM SCREW SIZE.

LONGER SCREWS MAY TOUCH AND DAMAGE COMPONENTS INSIDE THE CHASSIS.

4. Wire the new radio to the vehicle as per step 4 above.
5. Mount the new radio assembly to the dashboard or center console using the reverse procedure of step 1.

Toll-Free Installation Assistance

The installation and wiring connections for this unit are so simple, we doubt you'll need our help, but, if you do, we're here to help you. Just call our toll-free telephone assistance line at **1-800-645-4994** during the days and hours shown (U.S.A. and Canada only).

DAY	TIME ZONE			
	PACIFIC	MOUNTAIN	CENTRAL	EASTERN
MON.-FRI.	5:30AM - 4PM	6:30AM - 5PM	7:30AM - 6PM	8:30AM - 7PM
SATURDAY	6AM - 2PM	7AM - 3PM	8AM - 4PM	9AM - 5PM

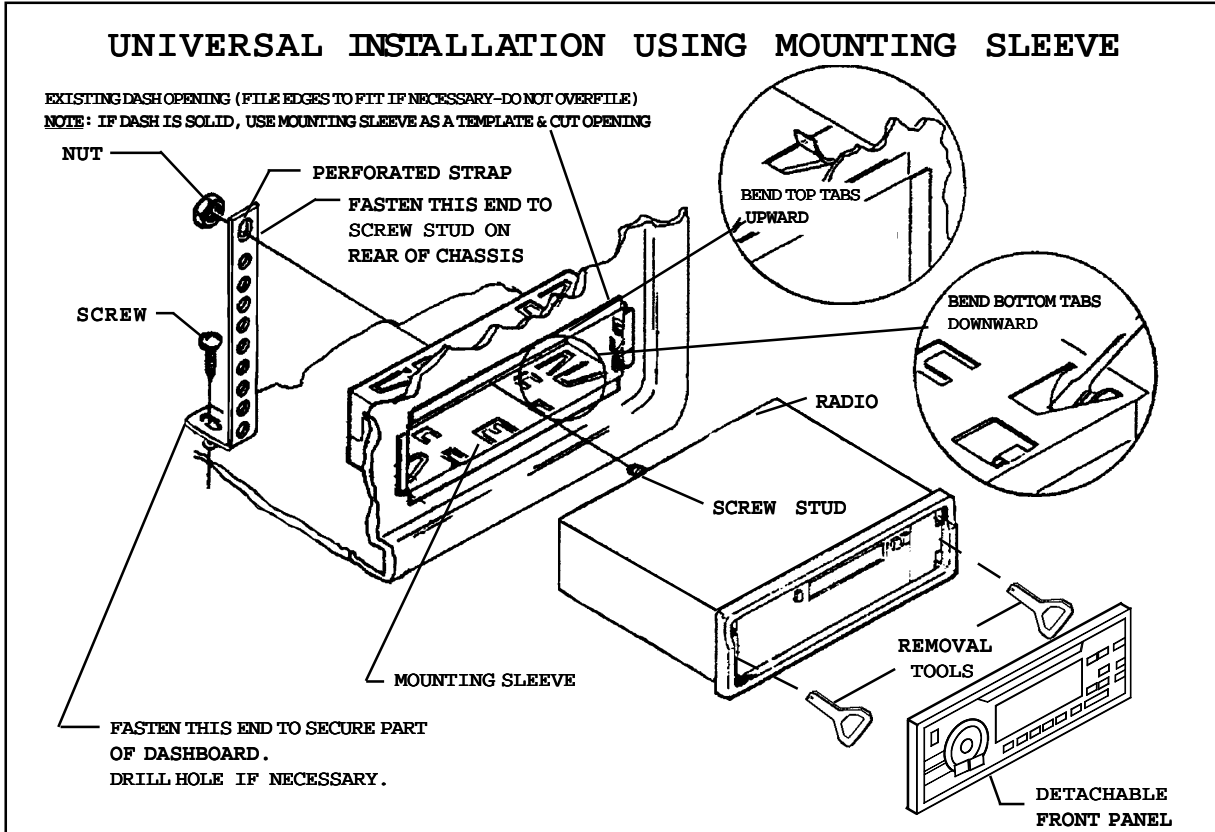

ISO INSTALLATION

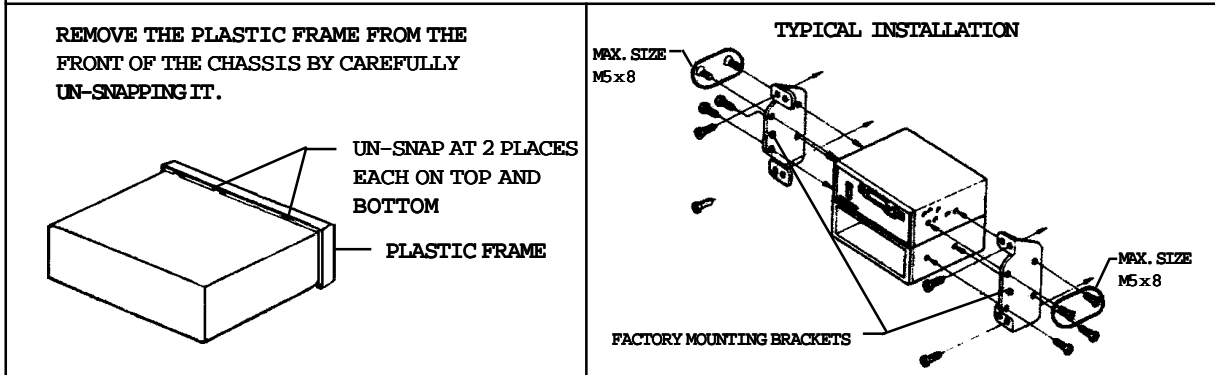

RADIO WIRING

REFER TO PAGE 4 FOR SPEAKER WIRING

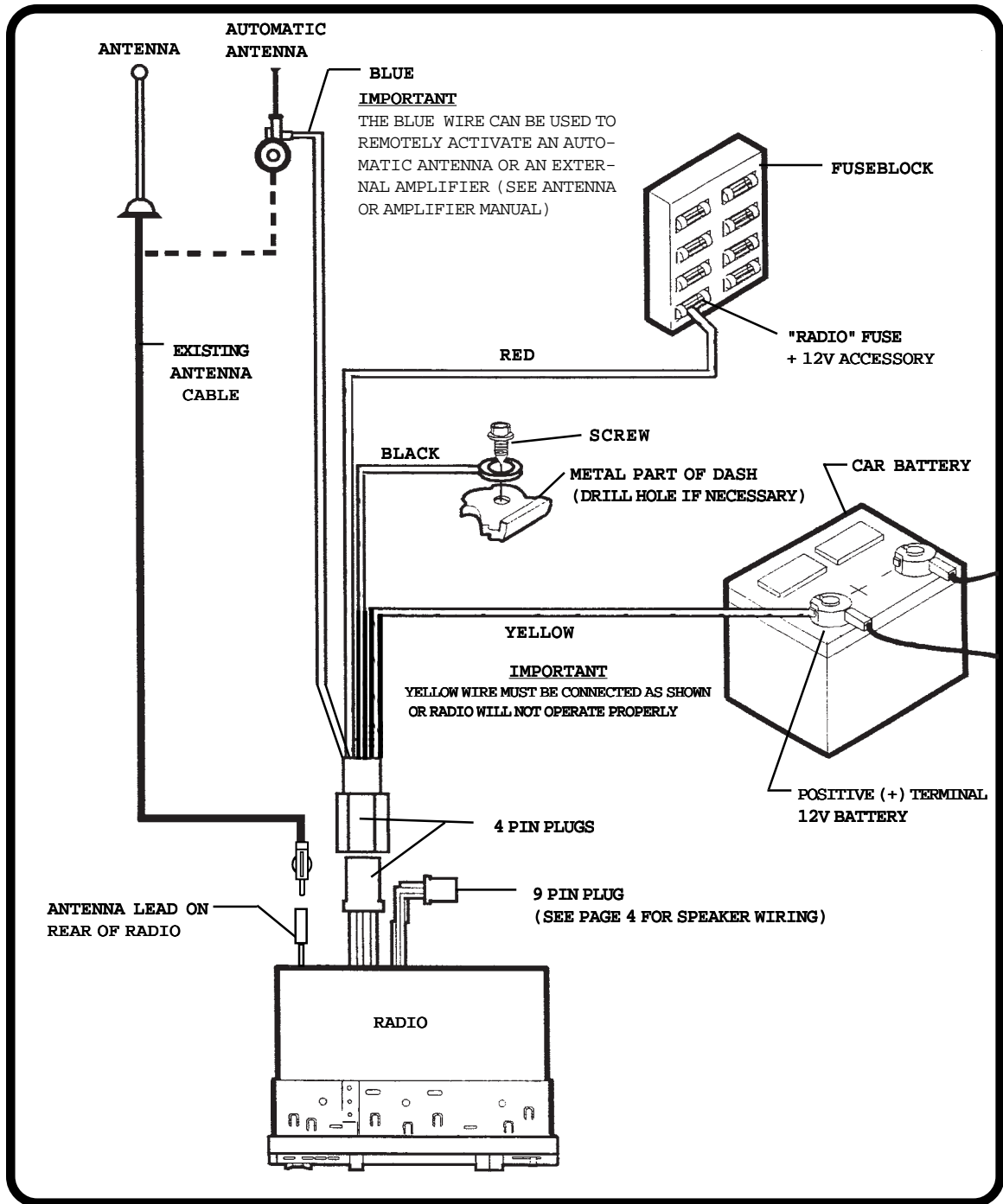

SPEAKER WIRING

REFER TO PAGE 3
FOR RADIO WIRING

WARNING!

- ¹ THE AMPLIFIERS IN THIS RADIO ARE **ONLY** DESIGNED FOR USE WITH 4 SPEAKERS.
- ¹ **NEVER** COMBINE (BRIDGE) OUTPUTS FOR USE WITH 2 SPEAKERS.
- ¹ **NEVER** GROUND NEGATIVE SPEAKER LEADS TO CHASSIS GROUND.
- ¹ FAILURE TO WIRE EXACTLY AS SHOWN BELOW MAY CAUSE ELECTRICAL DAMAGE TO THE RADIO.

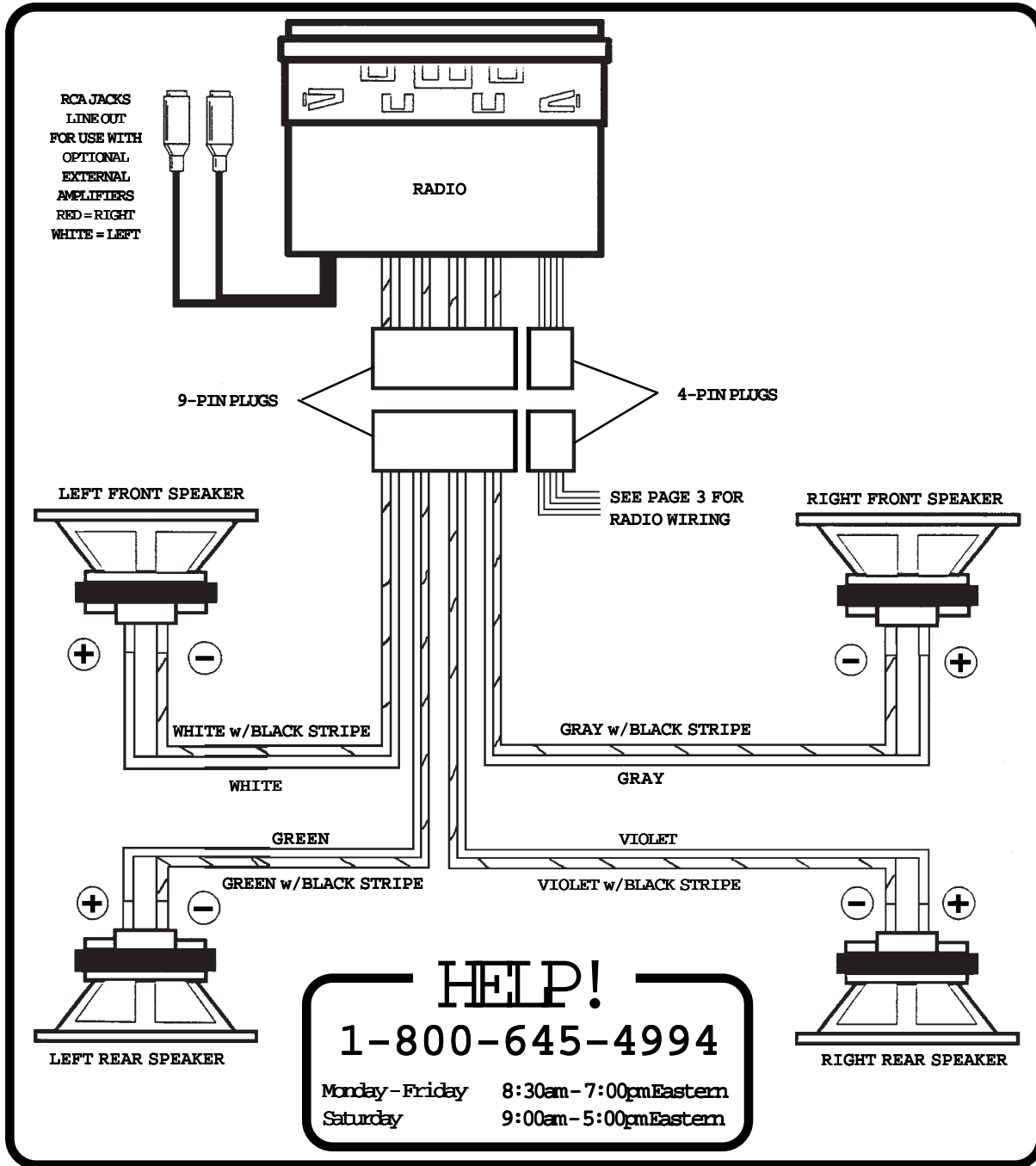

OPERATING INSTRUCTIONS

**ON-OFF POWER BUTTON**

Press this button to turn the unit on ("P ON" will briefly appear on the display panel) or off.

**VOLUME/LEVEL CONTROL**

To increase the volume level, turn the knob clockwise. The volume will increase and the level will be shown on the display panel from a minimum of "VOL 00" to a maximum of "VOL 63". To decrease the volume level, turn the knob counter-clockwise. The display will automatically return to the normal indication 5 seconds after the last volume adjustment or when another function is activated. This control is also used in conjunction with the Select button to adjust the bass, treble, balance, and fader levels as described in , , and .

**SELECT BUTTON**

This button is used to select the audio function (bass, treble, balance, or fade) to be adjusted using the Level control . Pressing the Select button once will set the unit for volume adjustment ("VOL" will appear on the display panel). Pressing the button additional times will select bass adjustment ("BAS" on the display), treble ("TRE"), balance ("BA"), or fader ("FA"). The display will automatically return to the normal indication 5 seconds after the last adjustment or when another function is activated.

**BASS CONTROL**

To adjust the bass level, first select the Bass mode by pressing the Select button so the "BAS" indication appears on the display panel. Within 5 seconds of choosing the Bass mode, turn the Level control counter-clockwise to decrease the bass response or clockwise to increase it as desired. The level will be shown on the display panel from a minimum "BAS-06" to a maximum of "BAS+06" ("BAS 00" indicates flat response). The display will automatically return to the normal indication 5 seconds after the last adjustment or when another function is activated.

**TREBLE CONTROL**

To adjust the treble level, first select the Treble mode by pressing the Select button so the "TRE" indication appears on the display panel. Within 5 seconds of choosing the Treble mode, turn the Level control counter-clockwise to decrease the treble response or clockwise to increase it as desired. The level will be shown on the display panel from a minimum "TRE-06" to a maximum of "TRE+06" ("TRE 00" indicates flat response). The display will automatically return to the normal indication 5 seconds after the last adjustment or when another function is activated.



LEFT/RIGHT BALANCE CONTROL

To adjust the left-right speaker balance, first select the Balance mode by pressing the Select button so the "BA" indication appears on the display panel. Within 5 seconds of choosing the Balance mode, turn the Level control counter-clockwise to adjust the stereo balance to the left channel speakers or clockwise to adjust it to the right channel speakers. The balance position will be shown on the display panel from "BA L31" (full left) to "BA R31" (full right). When the volume level between the left and right speakers is equal, "BA 00" will be shown on the display panel. The display will automatically return to the normal indication 5 seconds after the last adjustment or when another function is activated.



FRONT/REAR FADER CONTROL

To adjust the front-rear speaker balance, first select the Fader mode by pressing the Select button so the "FA" indication appears on the display panel. Within 5 seconds of choosing the Fader mode, turn the Level control counter-clockwise to adjust the front-rear speaker balance to the rear speakers or clockwise to adjust it to the front speakers. The fader position will be shown on the display panel from "FA R31" (full rear) to "FA F31" (full front). When the level between the front and rear speakers is equal, "FA 00" will be shown on the display panel. The display will automatically return to the normal indication 5 seconds after the last adjustment or when another function is activated.



AUDIO EQUALIZER SELECTOR (EQ)

The Audio Equalizer feature adjusts the frequency response, allowing you to tailor the sound reproduction to 3 different acoustic settings. Each press of the button will select a different effect (**ROCK** , **CLAS** or **POP**) as shown by the indication on the display panel. Pressing the button again will restore normal stereo reproduction (**FLAT** indication on the display panel).



LOUDNESS CONTOUR (LOUD)

When listening to music at low volume levels, this feature will boost the bass and treble ranges to compensate for the characteristics of human hearing. Press the button momentarily to activate this feature and the indication "LOUD" will appear on the display panel. Pressing the button again momentarily will deactivate the feature (the "LOUD" indication will disappear from the display panel).



AUDIO MUTE SELECTOR (MUTE)

Press this button momentarily to mute the volume from the system ("MUTE" will flash on the display panel). Pressing the button again or adjusting the Volume control will return to the volume level setting in use before the Mute function was activated.



**AM/FM BAND SELECTOR (BAND)
RADIO MODE SELECTOR**

Each time this button is pressed, the radio band is changed. The indications "AM", "FM", "FMII" or "FMIII" will appear in the display panel according to your selection.

During cassette play, pressing this button will return to radio operation.



**MANUAL UP/DOWN TUNING (/)
AUTOMATIC SEEK TUNING (SEEK)**

To manually select a radio station, momentarily press the Up Tuning () side of the button to advance the unit one digit higher or the Down Tuning () side of the button to tune downward.

Pressing either side of the button for longer than 0.5 seconds will activate the Automatic Seek Tuning function. The radio will seek the next station in the selected direction and stop at that frequency. The Seek function can be stopped by pressing the button again or activating any other tuning function.



LOCAL/DISTANT SELECTOR (LO/DX)

This feature is used to select the strength of the signals at which the radio will stop during Automatic Seek Tuning. Pressing the button will select the Local setting ("LOC" will appear on the display panel) and only strong (local) stations will be received. Pressing the button again will select the Distant setting ("LOC" will disappear from the display panel) and the radio will stop at a wider range of signals, including weaker (more distant) stations.



FM MONO/STEREO SELECTOR (MONO)

During FM radio operation, this button is used to select mono or stereo reception of the broadcast signal. Under normal reception conditions, the unit should be left in the stereo mode as indicated by the "ST" on the display panel and the symbol when tuned to an FM stereo signal. If the stereo signal is too noisy for comfortable listening, press the FM Mono/Stereo Selector button to switch to mono reception (the "ST" and indications will disappear

from the display panel). To return to stereo reception mode, press the button again so that the "ST" indication appears on the display panel.



PRE-SET SCAN (PS)

AUTO-STORE TUNING (AS)

Press this button momentarily to scan the stations pre-set into the memories of the band in use. The unit will stop at each pre-set station for 5 seconds before continuing to the next pre-set station (the pre-set number on the display panel will flash during Pre-Set Scan operation). Press the button again momentarily to stop Pre-Set Scan operation and remain on the selected frequency.

Pressing and holding the button for longer than 2 seconds will activate the Auto-Store Tuning feature ("A/T" will appear on the display panel) which will automatically scan and enter up to 6 stations into the pre-set memories on the band in use. After entering the stations into the memories, the unit will automatically stop at each station for 5 seconds so each can be heard. If you have already set the pre-set memories to your favorite stations, activating the Auto-Store Tuning feature will erase those stations and enter the new ones. This feature is most useful when travelling in a new area where you are not familiar with the local stations.



STATION PRE-SET MEMORIES

To set any of the 6 pre-set memories in each band, use the following procedure:

1. Turn the radio on and select the desired band.
2. Select the first station to be pre-set using the Manual Up/Down or Automatic Seek Tuning Controls .
3. Press the pre-set button to be set and continue to hold it in for approximately 2 seconds. The pre-set number will appear on the display panel indicating that the station is now set into that pre-set memory position. The station can now be recalled at any time by pressing that button.
4. Repeat the above procedure for the remaining 5 pre-sets on that band and for the other 4 bands on the unit.



LIQUID CRYSTAL DISPLAY PANEL

The Liquid Crystal Display (LCD) panel displays the frequency, time, and activated functions.

NOTE: It is a characteristic of LCD panels that, if subjected to cold temperatures for an extended period of time, they may take longer to illuminate than under normal conditions. In addition, the

visibility of the numbers on the LCD may slightly decrease. The LCD read-out will return to normal



when the temperature increases to a normal range.

SPECTRUM ANALYZER DISPLAY

The Spectrum Analyzer Display feature incorporated in this unit breaks down the audio frequency spectrum into 5 bands and provides a visual indication of the amount of audio signal within each of these bands. The number of illuminated bars (1 to 10) shows the instantaneous signal level in the band around the indicated frequencies (105Hz., 340Hz., 1KHz., 3.4KHz., and 10.5KHz.).



CASSETTE DOOR

To access the cassette door, press the Front Panel Release button  so that the panel drops to its lowered position. Hold the cassette with the exposed tape edge to the right and insert it fully into the cassette door until the cassette is engaged and begins playing ("TAPE" will appear on the display panel). When the cassette reaches the end on the side of the tape being played, the unit will automatically change direction of play as shown by the arrow indications on the display panel.

NOTE: Observe cassette operation cautions in Care and Maintenance section of this manual.





FAST-FORWARD/REWIND BUTTONS

(▶▶ / ◀◀)

These buttons cause the tape to move rapidly in the direction indicated by the arrows. For example, if the ▶▶ button is pushed when the tape is moving from left to right (▶ on the display panel), the tape will fast-forward. If the button is pressed while the tape is moving from right to left (◀ on the display panel), the tape will rewind. To stop fast tape movement, lightly push the opposite button. If the tape is allowed to fast-forward or rewind all the way to the end, play will automatically begin again from that point.



PROGRAM SELECTOR

To manually reverse tape direction and play the other side (program) of the cassette, lightly push both the Fast-Forward and Rewind buttons  and  at the same time. The change of direction will be shown by the arrows on the display panel.



EJECT BUTTON (▲)

Tape playback is stopped and the cassette is ejected by pressing this button located behind the front panel, next to the tape door. Radio operation will automatically

resume when the cassette is ejected.

NOTE: Never leave a cassette engaged in the player when not in use. Doing so can cause damage to the cassette and/or mechanism of the unit.

Always press the eject button and remove the cassette before removing the detachable front panel.



TAPE MODE SELECTOR (TAPE)

During radio operation, press this button to change to tape play if a cassette is already loaded in the unit (TAPE IN is shown on the display panel to indicate that a tape is loaded).



TIME/FREQUENCY SELECTOR (T/F)

Press this button to call the time display on the incorporated quartz clock. The display will return to the normal indication (radio frequency or "TAPE") after 5 seconds.



THEFT-DETERRENT L.E.D.

Located on the chassis behind the front panel, a light-emitting diode (L.E.D.) will flash when the panel is removed. The flashing light serves as a visual warning to the would-be thief that the unit has been disabled by removal of the front panel.



RE-SET BUTTON

A Re-Set button is located on the front of the chassis (front panel must be removed to access the button). The re-set circuitry is provided to protect the microprocessor circuitry and should only be activated under the following circumstances as it will erase the time and pre-set memories.

1. Upon initial installation after all wiring is completed.
2. If there is a malfunction of any of the switches on the unit, pressing the Re-Set button may clear the system and return to normal operation.





FRONT PANEL RELEASE BUTTON (OPEN)

This button is used to release the mechanism that holds the front panel to the chassis. To detach the front panel, press the button so that the panel drops to the lowered position. Grasp the panel at the middle and pull it off of the chassis. After removing the panel, push the metal plate back up to the vertical position. To re-attach the panel, press it straight onto the chassis until the mechanism locks it into place.

NOTES ON USE OF FRONT PANEL

1. Make sure the front panel is right-side-up when attaching it to the chassis as it cannot be attached when up-side down.
2. Do not press very hard on the front panel when attaching it to the chassis. No more than light to moderate pressure should be needed.
3. When attaching the front panel, make sure it is centered in the chassis frame and is pressed straight into position.
4. When taking the front panel with you, please use the supplied carrying case to protect the panel from dirt and damage. Make sure there is no dust or dirt on the electrical terminals on the back of the panel as this could cause intermittent operation or other malfunctions.

SETTING THE CLOCK

1. Switch the vehicle ignition and radio "on".
2. Momentarily press the Time/Frequency Selector button  so that the time is shown on the display panel.
3. Within 5 seconds (while the time still appears on the display), press and hold the Time/Frequency Selector and the Down Tuning () button to adjust the hours or the Up Tuning () button to adjust the minutes to the correct time.
4. When the correct time is set, release the Time/Frequency Selector. After five seconds the display will return to the normal indication.

SPECIFICATIONS

Size:	7" W x 2" H x 6" D 178 mm x 50 mm x 150 mm
Operating Voltage:	12 volts DC, negative ground
Output Power:	100 watts maximum (25 watts x 4 channels)
Output Wiring:	Floating-ground type designed for 4 speaker use. The amplifiers in this unit are NOT designed for use with 2 speakers. RCA pre-amp level outputs.
Output Impedance:	Compatible with 4 - 8 ohm speakers
Pre-Amp Output:	500 mv.
Tuning Range:	AM: 530 - 1,710 KHz. (10 KHz. step) FM: 87.5 - 107.9 MHz. (200 KHz. step)
Sensitivity:	AM: 20 uv. FM: 1.5 uv.
FM Stereo Separation:	30 dB
Tape Frequency Response:	50-10,000 Hz.
Tape S/N Ratio:	50 dB
Wow & Flutter:	0.15% WRMS

*Specifications are subject to change without notice.

CARE AND MAINTENANCE

The radio portion of your new sound system does not require any maintenance. We recommend you keep this manual for future reference on how to set the clock and for general reference of the many features found in this unit.

As with any cassette player, the cassette section of this sound system does require a minimum of maintenance to keep it in good working condition. The following simple care and maintenance suggestions should be followed to prevent malfunctions of the cassette system.

Cassette Care:

1. Purchase a cassette cleaning kit from your local retail store. Use it! At least every 20 to 30 hours of operation you must clean the cassette mechanism. A dirty cassette player will have a poor sound.
2. Do not use cassettes that exceed 45 minutes of play on each side.
3. Do not insert a cassette that appears to be broken, twisted or dirty or with loose or torn labels on it.
4. Always keep your cassettes away from direct sunlight or exposure to sub-freezing conditions. If a cassette is cold, allow it to warm up before use.
5. Do not keep a cassette in the player when not in use.
6. Before inserting a cassette in the player, check that the tape is tightly wound on the reels. Take up any excess slack using a pencil to turn the drive hub in the cassette (see diagram).

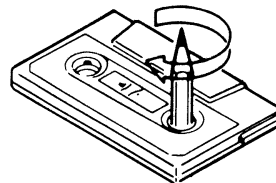

TROUBLESHOOTING

PROBLEM	PROBABLE CAUSE	CHECK FOLLOWING
Unit completely inoperative no lights, no sound	Incorrect power connection	Red wire to +12V ACC. and Yellow wire to +12V battery
	Blown fuse	Check fuses in wires listed above and check car fuse block
Unit will not keep time or radio station memory	Incorrect power connection	Yellow wire is not connected to a "live" +12V battery source
	Blown fuse	Check fuse in Yellow wire and at car's fuse block
Noise on both radio and tape	Poor ground	Check Black wire for proper grounding
	Dirty or corroded battery posts	Clean and tighten connection
	Problem also existed with previous radio you removed	Consult your local garage mechanic-car may need tune-up or noise filter
Noise on radio only	Antenna	Check that antenna base is grounded. Test with antenna disconnected. If noise goes away, replace antenna
Poor FM reception and almost no AM reception	Antenna	Replace antenna and antenna cable
Poor FM reception and good AM reception	FM Local-Distant switch	Check if unit has a Local-Distant switch and set to "Distant" position.
No sound on one speaker (both radio and tape)	Wiring	Check speaker wiring
	Speaker	Test with good speaker
	Radio Operation	Check balance and fader controls
Poor sound on tape only (after one month or more of tape usage)	Dirty tape mechanism	Clean tape head and mechanism
Poor sound - new unit	For radios with 40 watts or more output power	Check rating of speakers for sufficient power capacity
		Check that speakers are in good condition
		Check that none of the speaker wires are grounded
	For all radios	Check speaker wiring

12 MONTH LIMITED WARRANTY

AUDIOVOX CORPORATION (the Company) warrants to the original retail purchaser of this product that should this product or any part thereof, under normal use and conditions, be proven defective in material or workmanship within 12 months from the date of original purchase, such defect(s) will be repaired or replaced with new or reconditioned product (at the Company's option) without charge for parts and repair labor.

To obtain repair or replacement within the terms of this Warranty, the product is to be delivered with proof of warranty coverage (e.g. dated bill of sale), specification of defect(s), transportation prepaid, to the warranty center at the address shown below.

This Warranty does not extend to the elimination of car static or motor noise, to correction of antenna problems, to costs incurred for installation, removal, or reinstallation of the product, or damage to tapes, compact discs, speakers, accessories, or vehicle electrical systems.

This Warranty does not apply to any product or part thereof which, in the opinion of the Company, has suffered or been damaged through alteration, improper installation, mishandling, misuse, neglect, accident, or by removal or defacement of the factory serial number/bar code label(s). THE EXTENT OF THE COMPANY'S LIABILITY UNDER THIS WARRANTY IS LIMITED TO THE REPAIR OR REPLACEMENT PROVIDED ABOVE AND, IN NO EVENT, SHALL THE COMPANY'S LIABILITY EXCEED THE PURCHASE PRICE PAID BY PURCHASER FOR THE PRODUCT.

This Warranty is in lieu of all other express warranties or liabilities. ANY IMPLIED WARRANTIES, INCLUDING ANY IMPLIED WARRANTY OF MERCHANTABILITY, SHALL BE LIMITED TO THE DURATION OF THIS WRITTEN WARRANTY. ANY ACTION FOR BREACH OF ANY WARRANTY HEREUNDER INCLUDING ANY IMPLIED WARRANTY OF MERCHANTABILITY MUST BE BROUGHT WITHIN A PERIOD OF 30 MONTHS FROM DATE OF ORIGINAL PURCHASE. IN NO CASE SHALL THE COMPANY BE LIABLE FOR ANY CONSEQUENTIAL OR INCIDENTAL DAMAGES FOR BREACH OF THIS OR ANY OTHER WARRANTY, EXPRESS OR IMPLIED, WHATSOEVER. No person or representative is authorized to assume for the Company any liability other than expressed herein in connection with the sale of this product.

Some states do not allow limitations on how long an implied warranty lasts or the exclusion or limitation of incidental or consequential damage so the above limitations or exclusions may not apply to you. This Warranty gives you specific legal rights and you may also have other rights which vary from state to state.

U.S.A. : AUDIOVOX CORPORATION, 150 MARCUS BLVD., HAUPPAUGE, NEW YORK 11788 1 1-800-645-4994

CANADA: CALL 1-800-645-4994 FOR LOCATION OF WARRANTY STATION SERVING YOUR AREA

128-4270E

Free Manuals Download Website

<http://myh66.com>

<http://usermanuals.us>

<http://www.somanuals.com>

<http://www.4manuals.cc>

<http://www.manual-lib.com>

<http://www.404manual.com>

<http://www.luxmanual.com>

<http://aubethermostatmanual.com>

Golf course search by state

<http://golfingnear.com>

Email search by domain

<http://emailbydomain.com>

Auto manuals search

<http://auto.somanuals.com>

TV manuals search

<http://tv.somanuals.com>