



AUDIOVOX[®]
ELECTRONICS CORP.

6 COMPACT DISC AUTO CHANGER

MODEL : PAV-6CDP
OWNER' S MANUAL

FEATURES

- * Tracks from 6 CDs stored in the disc magazine can be selected and played.
- * Horizontal, vertical, angled and suspended installation.

PRECAUTIONS

- * Do not install the unit in a location where it may be subjected to :
 - direct sun or other forms of excessive temperature.
 - excessive heat.
 - fluid, rain or moisture.
 - excessive dirt or dust.
 - excessive vibration.
- * This unit is designed to be operated on a 13.8 volt DC negative ground electrical system only.

Notes on CDs

- * A defective or soiled disc stored in the disc magazine can cause sound to drop out during play.
- * Always handle a disc by holding its inner and outer edges.
- * Do not touch the surface of the unlabeled side of the disc.

- * Do not stick paper or tape etc. onto a disc.

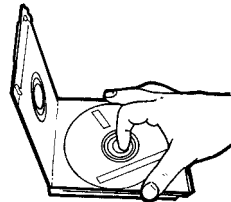

PRECAUTIONS

- * Do not expose the discs to direct sunlight or excessive heat.

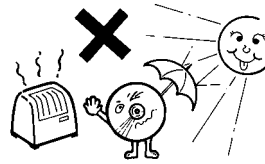

- * Clean the discs before inserting them into the disc magazine.
Always clean a disc from center outward with a cleaning cloth.

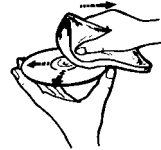

- * Never use solvents such as benzene or alcohol to clean a disc.
- * You cannot play an 8cm(3 inch) CD even with the specially designed adapter.

Notes on the disc magazine

- * Do not leave the disc magazine in a place subject to excessive temperature or humidity.
- * Do not insert more than one disc per slot.
- * Do not drop the disc magazine.

HOW TO USE COMPACT DISC MAGAZINE

1. * Pull out the slot by pulling the part **A** with finger.

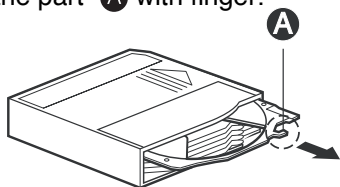

- * With the label side up, insert a CD all the way

Label side
facing upward

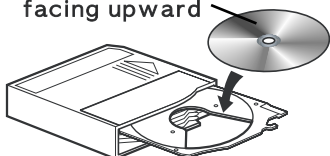

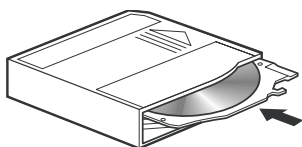

6 discs, one in each slot

- * Push slot and close it.

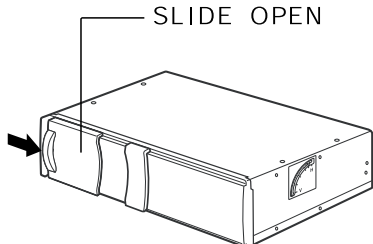

2. SLIDE OPEN



3. Insert the magazine firmly (which has been taken out of the unit) with the  mark visible on the top side.

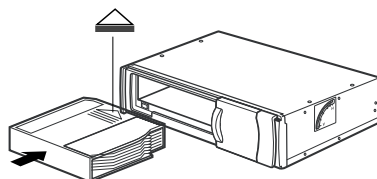

Disc magazine

To remove

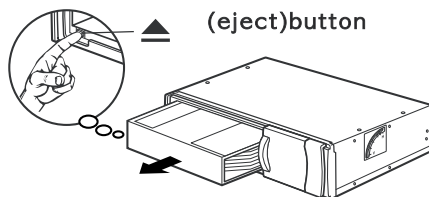





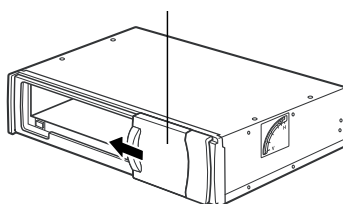

- * Press the eject button and pull out the disc magazine.

4. SLIDE CLOSE

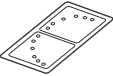

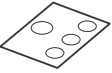
INSTALLATION

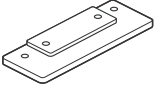
Supplied mounting kit

<p>① BRACKET X 2</p> 	<p>② Double-sided tape X 1</p> 	<p>③ TAPPING SCREW X 4</p> 	<p>④ Adhesive label X 1</p> 
<p>⑤ WASHER SCREW X 4</p> 	<p>⑥ PLATE BRACKET</p> 	<p>⑦ BOLT X 4</p> 	<p>⑧ NUT X 4</p> 

Precautions

Select the mounting location very carefully by referring to the following points

- * Make sure that there is not a fuel tank, wiring or piping on the other side of the mounting surface.
- * Make sure that the installation of the unit will not hinder the movement of the trunk lid or interfere with the spare tire etc.
- * Use only the supplied mounting kit for a safe and proper installation.

INSTALLATIONS

Removing the transport screws

Find the 3 transport screws at the bottom of the unit, which lock the unit's mechanism during transport. Remove these screws before installation and attach the supplied adhesive labels ④ over the holes. Retain these screws and replace them in the original positions if the unit is transported for service or maintenance.

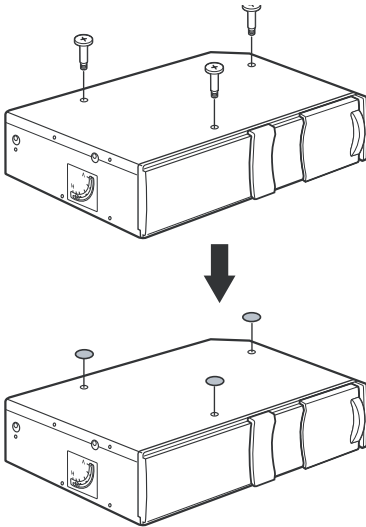

Installing the unit

Mounting angle setting lever
Be sure to adjust Mounting Angle Setting Lever(A) to appropriate angle; 0° for horizontal, 22.5° angle, 45° angle, 67.5 angle, 80° angle, or 90° for vertical.

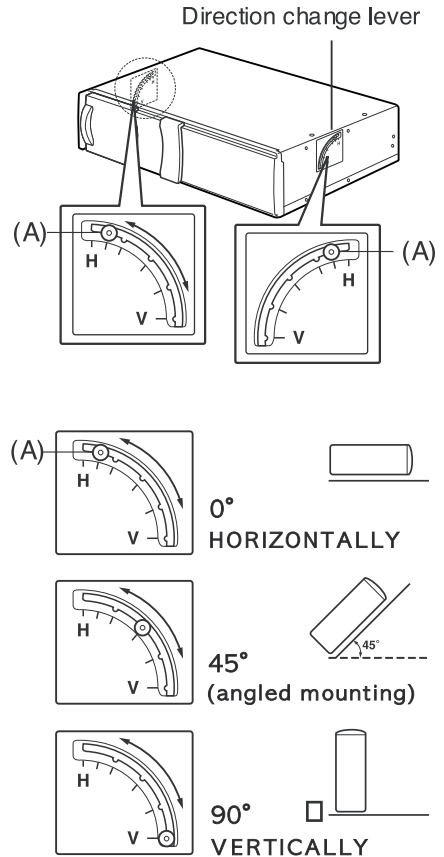

INSTALLATIONS

After adjustment, be sure to attach the Double side Tape .

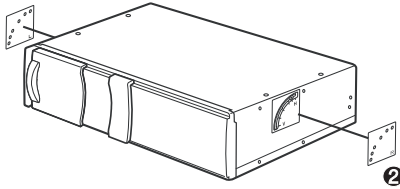

Note

Do the same procedure on the other side of the unit.

Horizontal installation

Construction

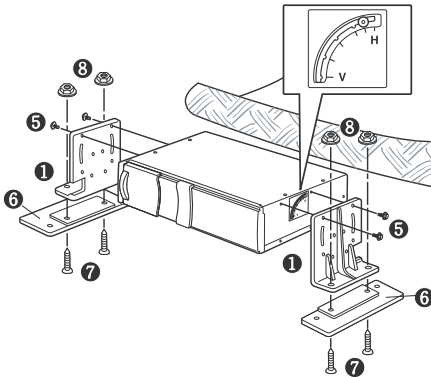

Removing temporarily

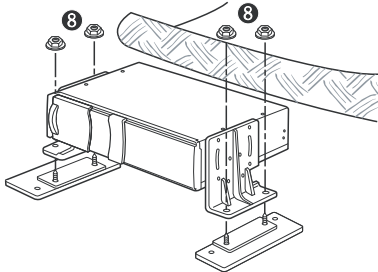

Making holes on the carpet

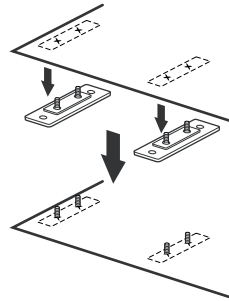

Completion

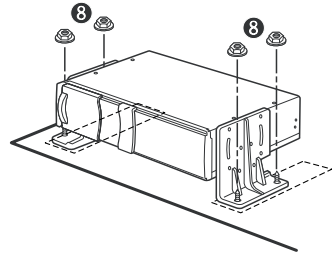

Note

About parts numbers ① ② ⑤ ⑥ ⑦ ⑧, refer to page 4. **angled installation**

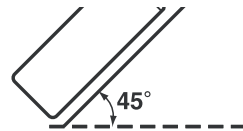

Be sure to turn the mounting angle setting dial to the 45° position.

INSTALLATIONS

Vertical installation

1. Construction

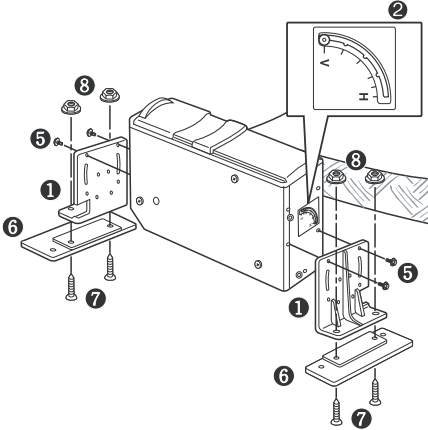

2. Removing temporarily

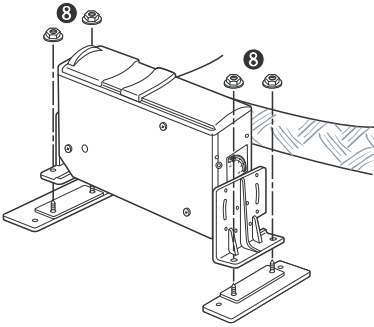

3. Making holes on the carpet

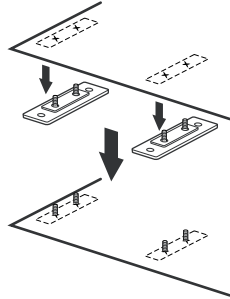

4. Completion

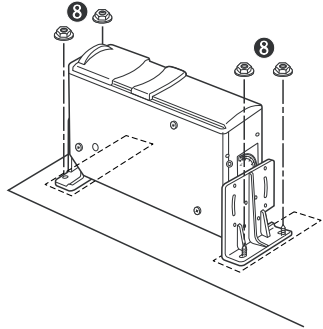

Note

About parts numbers ① ② ⑤ ⑥ ⑦ ⑧, refer to page 4.

INSTALLATIONS

Suspended installation

When installing the unit in the trunk under the rear window shelf, observe the following.

- Make sure that the unit is suspended horizontally.
- Select the mounting location carefully so that the unit does not hinder the movement of the torsion bars of the trunk lid.
- Make sure that there is nothing on the other side of the mounting location before drilling the holes.
- Select the correct size screw to avoid damaging the vehicle rear deck.

1. Construction

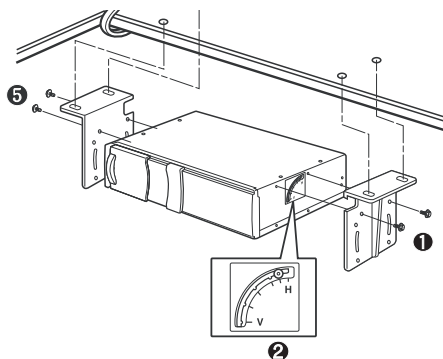

2. Making holes

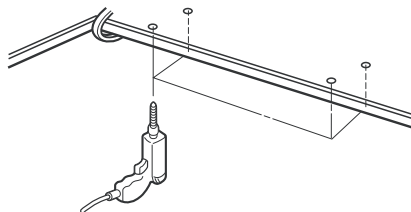

3. Completion

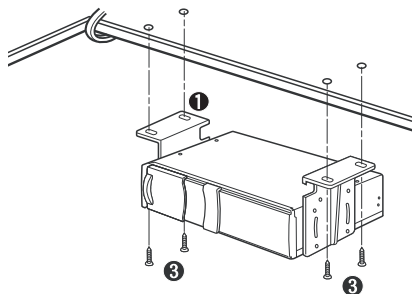

Note

About parts numbers ① ② ⑤, refer to page 4.

CONNECTIONS

When connecting, run the supplied connecting cable and connect to Audiovox model PAV-9 as illustrated here.

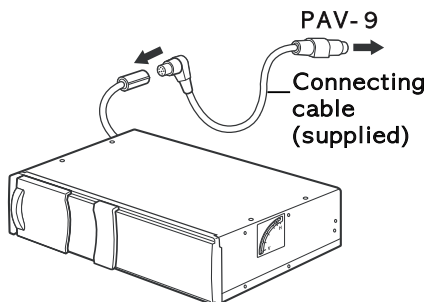

Caution

Make sure to disconnect the ground wire terminal of the car battery before making a connection in order to prevent short circuiting.

Note

Use only the supplied connecting cable. For complete operation instructions, refer to pages 18,19 and 20 in the PAV-9 owner's manual.

SPECIFICATIONS

General

System	6 CD Change system
Usable Disc	Compact disc (12cm)
Power Source	DC 13.8V Negative ground
Weight	1.9kg (4.2 lbs)
Dimensions(W×H×D)	254 × 63 × 157mm (10" × 2.5" × 6.2")
Frequency Response	20~20kHz
S/N Ratio	90dB
Channel Separation	70dB
T.H.D	0.03dB
Output Power	700 mV

Note

The design features and/or specifications are subject to change without notice.



12 MONTH LIMITED WARRANTY

Applies to Audiovox Video products

AUDIOVOX ELECTRONICS CORPORATION (the Company) warrants to the original retail purchaser of this product that should this product or any part thereof, under normal use and conditions, be proven defective in material or workmanship within 12 months from the date of original purchase, such defect(s) will be repaired or replaced with reconditioned product (at the Company's option) without charge for parts and repair labor.

To obtain repair or replacement within the terms of this Warranty, the product is to be delivered with proof of warranty coverage (e.g. dated bill of sale), specification of defect(s), transportation prepaid, to the Company at the address shown below.

This Warranty does not extend to the elimination of externally generated static or noise, to correction of antenna problems, to costs incurred for installation, removal or reinstallation of the product, or to damage to tapes, discs, speakers, accessories, or electrical systems.

This Warranty does not apply to any product or part thereof which, in the opinion of the Company, has suffered or been damaged through alteration, improper installation, mishandling, misuse, neglect, accident, or by removal or defacement of the factory serial number/bar code label (s). THE EXTENT OF THE COMPANY'S LIABILITY UNDER THIS WARRANTY IS LIMITED TO THE REPAIR OR REPLACEMENT PROVIDED ABOVE AND, IN NO EVENT, SHALL THE COMPANY'S LIABILITY EXCEED THE PURCHASE PRICE PAID BY PURCHASER FOR THE PRODUCT.

This Warranty is in lieu of all other express warranties or liabilities. ANY IMPLIED WARRANTIES, INCLUDING ANY IMPLIED WARRANTY OF MERCHANTABILITY, SHALL BE LIMITED TO THE DURATION OF THIS WRITTEN WARRANTY. ANY ACTION FOR BREACH OF ANY WARRANTY HEREUNDER INCLUDING ANY IMPLIED WARRANTY OF MERCHANTABILITY MUST BE BROUGHT WITHIN A PERIOD OF 30 MONTHS FROM DATE OF ORIGINAL PURCHASE. IN NO CASE SHALL THE COMPANY BE LIABLE FOR ANY CONSEQUENTIAL OR INCIDENTAL DAMAGES FOR BREACH OF THIS OR ANY OTHER WARRANTY, EXPRESS OR IMPLIED, WHATSOEVER. No person or representative is authorized to assume for the Company any liability other than expressed herein in connection within the sale of this product.

Some states do not allow limitations on how long an implied warranty lasts or the exclusion or limitation of incidental or consequential damage so the above limitations or exclusions may not apply to you. This Warranty gives you specific legal rights and you may also have other rights, which vary from state to states.

U.S.A : AUDIOVOX ELECTRONICS CORP, 150 MARCUS BLVD., HAUPPAUGE, NEW YORK 11788 *1-800-645-4994

CANADA : CALL 1-800-645-4994 FOR LOCATION OF WARRANTY STATION SERVING YOUR AREA.

Free Manuals Download Website

<http://myh66.com>

<http://usermanuals.us>

<http://www.somanuals.com>

<http://www.4manuals.cc>

<http://www.manual-lib.com>

<http://www.404manual.com>

<http://www.luxmanual.com>

<http://aubethermostatmanual.com>

Golf course search by state

<http://golfingnear.com>

Email search by domain

<http://emailbydomain.com>

Auto manuals search

<http://auto.somanuals.com>

TV manuals search

<http://tv.somanuals.com>