

**Pioneer** *sound.vision.soul*

COMPACT DISC PLAYER

# CDJ-1000MK2

Operating Instructions

COMPACT  
disc  
DIGITAL AUDIO

COMPACT  
disc  
DIGITAL AUDIO  
TEXT

# IMPORTANT



The lightning flash with arrowhead symbol, within an equilateral triangle, is intended to alert the user to the presence of uninsulated "dangerous voltage" within the product's enclosure that may be of sufficient magnitude to constitute a risk of electric shock to persons.



**CAUTION:**  
TO PREVENT THE RISK OF ELECTRIC SHOCK, DO NOT REMOVE COVER (OR BACK). NO USER-SERVICEABLE PARTS INSIDE. REFER SERVICING TO QUALIFIED SERVICE PERSONNEL.



The exclamation point within an equilateral triangle is intended to alert the user to the presence of important operating and maintenance (servicing) instructions in the literature accompanying the appliance.

**NOTE: THE NO USER-SERVICEABLE PARTS COMPARTMENT WARNING IS LOCATED ON THE APPLIANCE BOTTOM.**

# IMPORTANT SAFETY INSTRUCTIONS

H003 En

**READ INSTRUCTIONS** — All the safety and operating instructions should be read before the product is operated.

**RETAIN INSTRUCTIONS** — The safety and operating instructions should be retained for future reference.

**HEED WARNINGS** — All warnings on the product and in the operating instructions should be adhered to.

**FOLLOW INSTRUCTIONS** — All operating and use instructions should be followed.

**CLEANING** — Unplug this product from the wall outlet before cleaning. The product should be cleaned only with a polishing cloth or a soft dry cloth. Never clean with furniture wax, benzene, insecticides or other volatile liquids since they may corrode the cabinet.

**ATTACHMENTS** — Do not use attachments not recommended by the product manufacturer as they may cause hazards.

**WATER AND MOISTURE** — Do not use this product near water — for example, near a bathtub, wash bowl, kitchen sink, or laundry tub; in a wet basement; or near a swimming pool; and the like.

**ACCESSORIES** — Do not place this product on an unstable cart, stand, tripod, bracket, or table. The product may fall, causing serious injury to a child or adult, and serious damage to the product. Use only with a cart, stand, tripod, bracket, or table recommended by the manufacturer, or sold with the product. Any mounting of the product should follow the manufacturer's instructions, and should use a mounting accessory recommended by the manufacturer.

**CART** — A product and cart combination should be moved with care. Quick stops, excessive force, and uneven surfaces may cause the product and cart combination to overturn.



**VENTILATION** — Slots and openings in the cabinet are provided for ventilation and to ensure reliable operation of the product and to protect it from overheating, and these openings must not be blocked or covered. The openings should never be blocked by placing the product on a bed, sofa, rug, or other similar surface. This product should not be placed in a built-in installation such as a bookcase or rack unless proper ventilation is provided or the manufacturer's instructions have been adhered to.

**POWER SOURCES** — This product should be operated only from the type of power source indicated on the marking label. If you are not sure of the type of power supply to your home, consult your product dealer or local power company.

**LOCATION** — The appliance should be installed in a stable location.

**NONUSE PERIODS** — The power cord of the appliance should be unplugged from the outlet when left unused for a long period of time.

## GROUNDING OR POLARIZATION

- If this product is equipped with a polarized alternating current line plug (a plug having one blade wider than the other), it will fit into the outlet only one way. This is a safety feature. If you are unable to insert the plug fully into the outlet, try reversing the plug. If the plug should still fail to fit, contact your electrician to replace your obsolete outlet. Do not defeat the safety purpose of the polarized plug.

- If this product is equipped with a three-wire grounding type plug, a plug having a third (grounding) pin, it will only fit into a grounding type power outlet. This is a safety feature. If you are unable to insert the plug into the outlet, contact your electrician to replace your obsolete outlet. Do not defeat the safety purpose of the grounding type plug.

**POWER-CORD PROTECTION** — Power-supply cords should be routed so that they are not likely to be walked on or pinched by items placed upon or against them, paying particular attention to cords at plugs, convenience receptacles, and the point where they exit from the product.

**OUTDOOR ANTENNA GROUNDING** — If an outside antenna or cable system is connected to the product, be sure the antenna or cable system is grounded so as to provide some protection against voltage surges and built-up static charges. Article 810 of the National Electrical Code, ANSI/NFPA 70, provides information with regard to proper grounding of the mast and supporting structure, grounding of the lead-in wire to an antenna discharge unit, size of grounding conductors, location of antenna-discharge unit, connection to grounding electrodes, and requirements for the grounding electrode. See Figure A.

**LIGHTNING** — For added protection for this product during a lightning storm, or when it is left unattended and unused for long periods of time, unplug it from the wall outlet and disconnect the antenna or cable system. This will prevent damage to the product due to lightning and power-line surges.

**POWER LINES** — An outside antenna system should not be located in the vicinity of overhead power lines or other electric light or power circuits, or where it can fall into such power lines or circuits. When installing an outside antenna system, extreme care should be taken to keep from touching such power lines or circuits as contact with them might be fatal.

**OVERLOADING** — Do not overload wall outlets, extension cords, or integral convenience receptacles as this can result in a risk of fire or electric shock.

**OBJECT AND LIQUID ENTRY** — Never push objects of any kind into this product through openings as they may touch dangerous voltage points or short-out parts that could result in a fire or electric shock. Never spill liquid of any kind on the product.

**SERVICING** — Do not attempt to service this product yourself as opening or removing covers may expose you to dangerous voltage or other hazards. Refer all servicing to qualified service personnel.

**DAMAGE REQUIRING SERVICE** — Unplug this product from the wall outlet and refer servicing to qualified service personnel under the following conditions:

- When the power-supply cord or plug is damaged.
- If liquid has been spilled, or objects have fallen into the product.
- If the product has been exposed to rain or water.
- If the product does not operate normally by following the operating instructions. Adjust only those controls that are covered by the operating instructions as an improper adjustment of other controls may result in damage and will often require extensive work by a qualified technician to restore the product to its normal operation.
- If the product has been dropped or damaged in any way.
- When the product exhibits a distinct change in performance — this indicates a need for service.

**REPLACEMENT PARTS** — When replacement parts are required, be sure the service technician has used replacement parts specified by the manufacturer or have the same characteristics as the original part. Unauthorized substitutions may result in fire, electric shock, or other hazards.

**SAFETY CHECK** — Upon completion of any service or repairs to this product, ask the service technician to perform safety checks to determine that the product is in proper operating condition.

**WALL OR CEILING MOUNTING** — The product should not be mounted to a wall or ceiling.

**HEAT** — The product should be situated away from heat sources such as radiators, heat registers, stoves, or other products (including amplifiers) that produce heat.

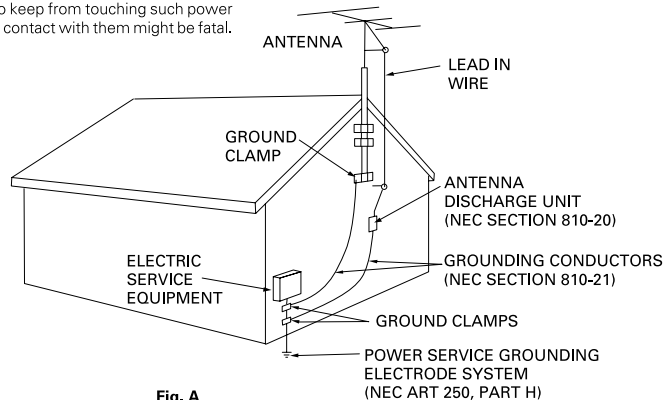

Fig. A

NEC — NATIONAL ELECTRICAL CODE

**WARNING:** THE APPARATUS IS NOT WATERPROOFS, TO PREVENT FIRE OR SHOCK HAZARD, DO NOT EXPOSE THIS APPARATUS TO RAIN OR MOISTURE AND DO NOT PUT ANY WATER SOURCE NEAR THIS APPARATUS, SUCH AS VASE, FLOWER POT, COSMETICS CONTAINER AND MEDICINE BOTTLE ETC.

H001BEn

**[For U.S. model]**

**IMPORTANT NOTICE**

H006AEn

The serial number for this equipment is located in the rear panel. Please write this serial number on your enclosed warranty card and keep it in a secure area. This is for your security.

**[For Canadian model]**

**CAUTION:** TO PREVENT ELECTRIC SHOCK, DO NOT USE THIS (POLARIZED) PLUG WITH AN EXTENSION CORD, RECEPTACLE OR OTHER OUTLET UNLESS THE BLADES CAN BE FULLY INSERTED TO PREVENT BLADE EXPOSURE.

**ATTENTION:** POUR PREVENIR LES CHOCS ELECTRIQUES NE PAS UTILISER CETTE FICHE POLARISEE AVEC UN PROLONGATEUR UNE PRISE DE COURANT OU UNE AUTRE SORTIE DE COURANT, SAUF SI LES LAMES PEUVENT ETRE INSEREES A FOND SANS EN LAISSER AUCUNE PARTIE A DECOUVERT.

H007A2L

**[For Canadian model]**

This Class B digital apparatus complies with Canadian ICES-003.

**[Pour le modèle Canadien]**

Cet appareil numérique de la classe B est conforme à la norme NMB-003 du Canada.

H009 2L

**CAUTION:**

This product satisfies FCC regulations when shielded cables and connectors are used to connect the unit to other equipment. To prevent electromagnetic interference with electric appliances such as radios and televisions, use shielded cables and connectors for connections.

H012 En

**POWER-CORD CAUTION**

S002 En

Handle the power cord by the plug. Do not pull out the plug by tugging the cord and never touch the power cord when your hands are wet as this could cause a short circuit or electric shock. Do not place the unit, a piece of furniture, etc., on the power cord, or pinch the cord. Never make a knot in the cord or tie it with other cords. The power cords should be routed such that they are not likely to be stepped on. A damaged power cord can cause a fire or give you an electrical shock. Check the power cord once in a while. When you find it damaged, ask your nearest PIONEER authorized service center or your dealer for a replacement.

**NOTE:** This equipment has been tested and found to comply with the limits for a Class B digital device, pursuant to Part 15 of the FCC Rules. These limits are designed to provide reasonable protection against harmful interference in a residential installation. This equipment generates, uses, and can radiate radio frequency energy and, if not installed and used in accordance with the instructions, may cause harmful interference to radio communications. However, there is no guarantee that interference will not occur in a particular installation. If this equipment does cause harmful interference to radio or television reception, which can be determined by turning the equipment off and on, the user is encouraged to try to correct the interference by one or more of the following measures:

- Reorient or relocate the receiving antenna.
- Increase the separation between the equipment and receiver.
- Connect the equipment into an outlet on a circuit different from that to which the receiver is connected.
- Consult the dealer or an experienced radio/TV technician for help.

H010 En

**Information to User**

H011 En

Alteration or modifications carried out without appropriate authorization may invalidate the user's right to operate the equipment.

**CAUTION :** USE OF CONTROLS OR ADJUSTMENTS OR PERFORMANCE OF PROCEDURES OTHER THAN THOSE SPECIFIED HEREIN MAY RESULT IN HAZARDOUS RADIATION EXPOSURE.

**CAUTION :** THE USE OF OPTICAL INSTRUMENTS WITH THIS PRODUCT WILL INCREASE EYE HAZARD.

H013 En

**WARNING:**

Handling the cord on this product or cords associated with accessories sold with the product will expose you to lead, a chemical known to the State of California and other governmental entities to cause cancer and birth defects or other reproductive harm.

***Wash hands after handling***

Thank you for buying this Pioneer product.

Please read through these operating instructions so you will know how to operate your model properly. After you have finished reading the instructions, put them away in a safe place for future reference.

In some countries or regions, the shape of the power plug and power outlet may sometimes differ from that shown in the explanatory drawings. However the method of connecting and operating the unit is the same.

K015 En

## CONTENTS

<b>CAUTIONS REGARDING HANDLING</b> .....	4
<b>FEATURES</b> .....	6
<b>CONNECTIONS</b> .....	7
<b>PANEL FACILITIES</b> .....	9
Top Panel .....	9
Display .....	10
Jog Dial Display .....	10
<b>DISC LOADING / UNLOADING</b> .....	11
<b>DJ PLAYER OPERATION</b> .....	11
Auto Cueing .....	11
Starting Playback .....	11
Stopping Playback .....	12
To Pause Play .....	12
Track Cueing .....	12
Fast-Forward / Fast-Reverse .....	12
Cue Point Settings .....	12
Changing Playback Speed .....	13
Applying Master Tempo .....	13
Jog Dial Functions .....	13
Mixing Different Tracks .....	13
<b>ADVANCED OPERATIONS</b> .....	14
Scratch Play .....	14
How to Spin .....	14
How to Brake .....	14
Hot Cue .....	14
Loop Playback .....	14
Reversing Playback .....	15
Fader Start Playback .....	15
Relay Play Using Two Players .....	15
Wave Display .....	15
About the CD TEXT .....	15
<b>USING CUE POINTS / LOOP POINTS MEMORY</b> .....	16
Using Internal Memory .....	16
Using a Multimedia Card .....	16
Copying MMC Data .....	17
Copying Data in the Internal Memory .....	17
<b>TROUBLESHOOTING</b> .....	18
<b>SPECIFICATIONS</b> .....	Back cover

## BEFORE OPERATIONS

### CAUTIONS REGARDING HANDLING

#### Location

**Install the player in a well-ventilated location where it will not be exposed to high temperatures or humidity.**

Do not install the player in a location which is exposed to direct sunlight, or near stoves or radiators. Excessive heat can adversely affect the cabinet and internal components. Installation of the player in a damp or dusty environment may also result in a malfunction and can be hazardous. Avoid installation near cookers etc., where the player may be exposed to oily smoke, steam or heat.

#### Installation guidelines

- Placing and using the compact disc player for long periods on heat-generating sources such as amplifiers or near spotlights, etc. will affect product performance. Avoid placing the player on heat-generating sources.
- Install this compact disc player as far as possible away from tuners and TV sets. A compact disc player installed in close proximity to such equipment may cause noise or degradation of the picture.
- Noise may be noticeable when an indoor antenna is used. In such cases, make use of an outdoor antenna or turn off power to the compact disc player.
- When the unit is used in a loud-sound environment, e.g., near a speaker, sound skip may occur. Install the unit away from the speaker or reduce the listening volume.
- Place this unit on a level surface and a stable platform.
- Be sure the player, including its audio and power supply cords, does not touch vibrating materials. Any cause of vibration other than the insulators may cause the disc to skip. Take special care when using the player while it is installed in a carrying case.

- **Please be sure to leave a space to allow for heat radiation.**

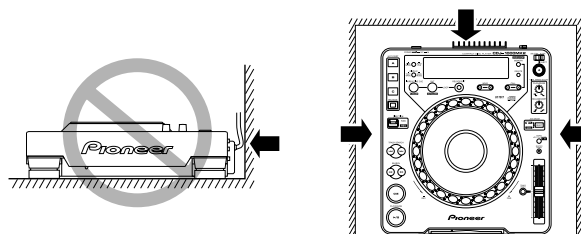

Do not place on or against vibrating materials!

#### About the Carrying Case

Since the upper surface of the jog dial incorporates a switch mechanism, do not allow pressure to be applied to the jog dial when placing the unit in the carrying case.

#### Cleaning the player

To clean the PLAYER wipe with a polishing or a soft, dry cloth. For stubborn dirt, moisten a soft cloth with a weak solution of neutral detergent (diluted in five to six parts water), wring the cloth well, and wipe away the dirt. Use a dry cloth to wipe the surface dry. Do not use volatile liquids such as benzene or thinner which will damage the unit.

#### CD lens cleaner

The player's pickup lens should not become dirty in normal use. If for some reason, the lens becomes soiled and malfunctions, contact your nearest PIONEER authorized service center. Lens cleaners for CD players are commercially available, but special care should be exercised in their use as some may cause damage to the lens.

**Storing discs**

- Discs are made of the same kinds of plastic used for conventional analog audio records. Be careful not to allow discs to warp. Always store discs in their cases vertically, avoiding locations with high heat, humidity, or extremely low temperatures. Avoid leaving discs in cars; the interior of a car in direct sunlight can become extremely hot.
- Always read and abide by the precautionary notes listed on disc labels.

**Condensation**

When this unit is brought into a warm room from previously cold surroundings or when the room temperature rises sharply, condensation may form inside the unit and impair its performance. In such cases, allow the unit to stand for about an hour or raise the room temperature gradually.

**Cleaning and handling compact discs**

- The presence of fingerprints or smudges on the surface of the disc will not directly affect the recorded signals, but, depending on the degree of contamination, the brightness of the light reflected from the signal surfaces may be reduced causing degradation of sound quality. Always keep your discs clean by wiping them gently with a soft cloth from the inner edge toward the outer edge.



- If a disc becomes very dirty, dampen a soft cloth with water, (be sure to wring it out well) and wipe the away dirt gently. Remove any water drops with another soft, dry cloth.
- Do not use record cleaning sprays or anti-static agents on discs. Never clean discs with benzene, thinner, or other volatile solvents or damage to the disc surface may result.

- With this player, use only those discs which display the mark shown right (Optical audio digital discs).
- SACD hybrid discs cannot be played.



- When holding discs, do not touch their signal surfaces. Hold by the edges, or by one edge and the center hole.
- Do not affix gummed labels or tape to the disc surface. Also, do not scratch or damage the label.
- Discs rotate at high speeds inside the player. Do not use damaged, cracked or warped discs.

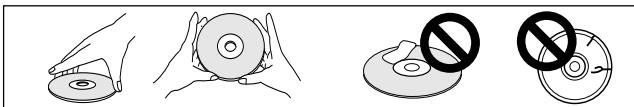

**Do not play a CD with a special shape**

Do not play a CD having other shape than a circular disc, such as heart shaped disc. Otherwise malfunction may occur.



**FORCED DISC EJECTION**

If the eject button does not function or the disc cannot be removed, pushing the pin provided into the forced ejection hole on the front panel will enable the disc to be removed.

When performing forced ejection, be sure to follow the precautions below.

- ① Be sure to turn OFF the power of the CD player, and check that the disc has stopped rotating. It takes about 60 seconds for the disc to stop rotating after the power has been turned OFF.

**If forced ejection is performed while the disc is rotating;**

- As the disc will be ejected outside the CD player rotating, it may hit your finger and cause injuries.
- As the disc will be rotating with the clamp unstable, it may be scratched.

**For the above reasons, never attempt to eject the disc forcibly while it is rotating.**

- ② Always use the pin provided (Do not use other objects). **The provided pin is found in a groove in the bottom surface of the player.**

When the provided forced eject pin is inserted fully into the forced eject hole on the front panel, the loaded disc is ejected about 5-10 mm from the loading slot, making it possible to remove it by hand.

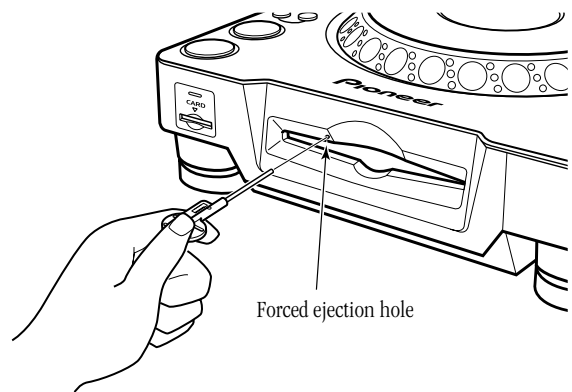

### FEATURES

The CDJ-1000MK2 compact disc player is designed for use by DJs providing all the functions and performance required in disco clubs while offering performance, sound quality and functionality superior to any analog player.

#### JOG DIAL

**The large 206 mm diameter Jog dial enables better handling than an analog turntable.**

#### PITCH BEND

This function changes the music tempo depending on direction of Jog dial rotation and speed of movement.

#### SCRATCH PLAY

In the **VINYL** mode when the surface of the Jog dial is pressed playback is discontinued and then continues according to the direction and speed the dial is rotated. You can also adjust the startup when the Jog dial is touched and released to create new DJ techniques.

#### FRAME SEARCH

Moves the disc from pause position in frame increments (1/75 sec) when the Jog dial is rotated in pause mode.

#### SUPER FAST SEARCH

You can search the disc faster than normal search or track search by holding down a **MANUAL SEARCH** button or **TRACK SEARCH** button as you turn the Jog dial.

#### ON JOG DISPLAY

The center of the jog dial displays information regarding disc status, cue point position, sound memory status, Jog dial touch-detection, and **VINYL** mode.

#### WAVE DISPLAY

This display makes it possible to find the breakpoint between tracks in advance and use it as mix point or end point in the same way as you can on an analog record by checking the position of the needle in the groove.

#### CUE/LOOP MEMORY

This unit can store cue points of each disc in internal memory or on a Multimedia Card (MMC) (sold separately) that can be recalled for each disc.

#### HOT CUE

Provides instant start from any of three pre-selected hot cue points (A, B or C).

#### REVERSE PLAY

Set the **DIRECTION** switch to its forward position ([REV] position) to play the music backwards.

#### TEMPO CONTROL

**100 mm high-precision slider coupled** with a 0.02% increment digital display (within a  $\pm 6\%$  range) allows exact control of speed to make tempo adjustments easy and accurate.

#### TEMPO CONTROL RANGE

The maximum variable range can be set to four variable ranges:  $\pm 6\%$ ,  $\pm 10\%$ ,  $\pm 16\%$  and  $\pm 100\%$  (WIDE) to facilitate adjustment.

#### TEMPO CONTROL RESET

Resets the tempo to 0% regardless of slider position.

#### MASTER TEMPO

Changes music tempo without changing pitch.

#### CUE

##### BACK CUE

After storing the Cue point in memory, press the **CUE** button while playing the unit to go back to the Cue point and start over.

##### AUTO CUE

Auto cue automatically locates the song's start point even if it differs from the track's frame, allowing the player to start instantly at a press of the **PLAY** button.

##### CUE POINT SAMPLER

The sound from the memorized cue point can be reproduced by one touch, which can be used as the start point check and the sampler.

#### REAL TIME SEAMLESS LOOP

This function simplifies setting and releasing loops. This function lets you set a loop while you are playing a track. A loop can also be set at the end of the track so that the track does not stop. In addition, an **ADJUST** mode has been added to enable one-touch adjustments to Loop-in and Loop-out points and facilitate loop operation.

#### RELOOP

**Allows you to replay a loop any number of times.**

Press the **RELOOP** button after releasing loop play to return to the loop start point. Clever use of on and off in combination with the rhythm make it possible to create new sound effects.

#### PLAYING ADDRESS

This bar graph provides a visual representation of track playback progress that enables you to see current playback position just like you can on an analog record by checking needle position. The length of the bar shows current position and a flashing bar provides advance notice of track end.

#### SLOT IN

Discs are loaded directly without opening doors or trays, making track selection that much faster.

#### FADER START

Quick start and back cue can be performed using the fader function on DJ mixers DJM-500, DJM-600, DJM-300 and DJM-3000 (all mixers are sold separately).

#### MULTI READ

CD-R, CD-RW discs can be replayed. (However, due to certain special characteristics of some discs, recorders as well as dirty or damaged discs, some discs may not replay properly.)

#### CD TEXT

CD TEXT informations are displayed if the CD includes the CD TEXT information.

## CONNECTIONS

- Before making or changing the connections, switch off the power and disconnect the power cord from the AC outlet.

### 1. Connecting to a DJ mixer (DJM-600, DJM-300, DJM-500, DJM-3000) (sound output and control terminal connection)

Use the supplied audio cables. Connect the white plug to the L (left) terminal and the red plug to the R (right) terminal.  
Connect the supplied control cord to enable control of the unit from the mixer to allow fader start play and back cue.

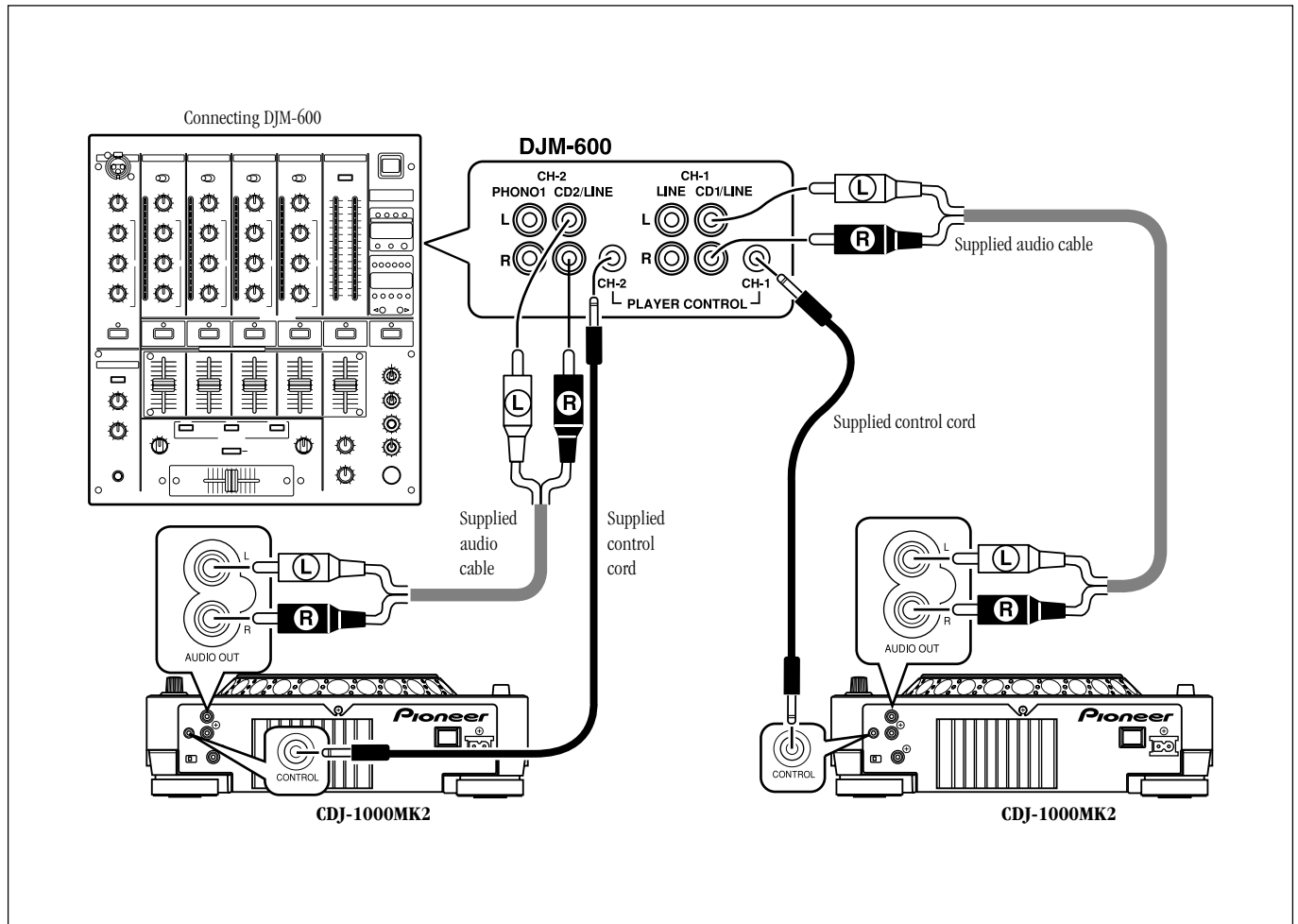

- Connections for the DJM-300 and DJM-500 are similar; use the supplied audio cables to connect the mixer's CD1 jacks to Player A, and CD2 jacks to Player B. When using the DJM-3000, Player A is connected to LINE 1 of CH-1, and Player B is connected to LINE 3 of CH-2.

### 2. Connecting control cord to allow relay play

Alternate playback can be automatically performed when the CONTROL terminals of two units are connected with the supplied control cord. ⇐ P.15

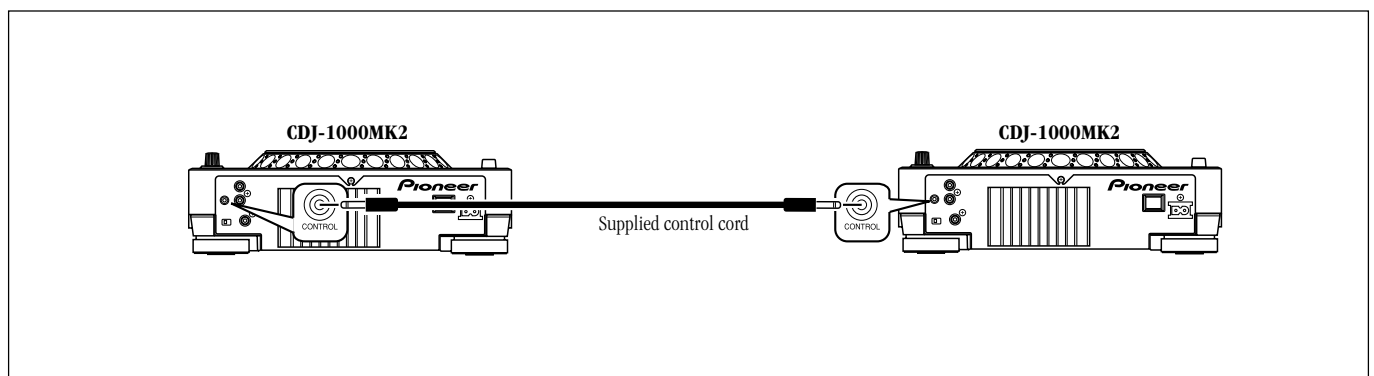

## BEFORE OPERATIONS: CONNECTIONS

### 3. Connecting to other devices

#### (A) Connecting to other mixers

Connect the **AUDIO OUT** terminal on the unit with the Line In terminal or AUX terminal on the mixer.  
(Do not use the Phono terminal. Otherwise the sound will become distorted and prevent normal playback.)

#### (B) Connecting to a stereo amplifier (when not using a DJ mixer)

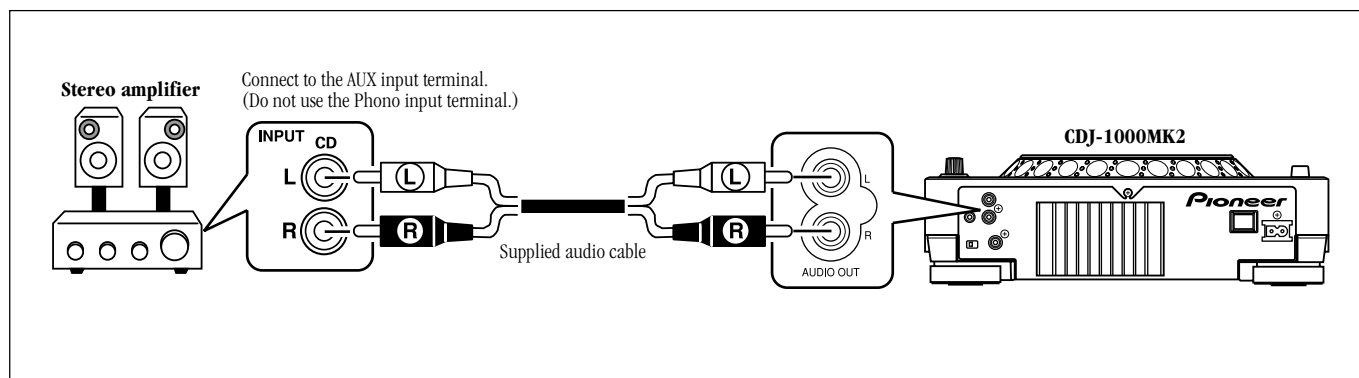

#### (C) Connecting to a component with a digital input terminal

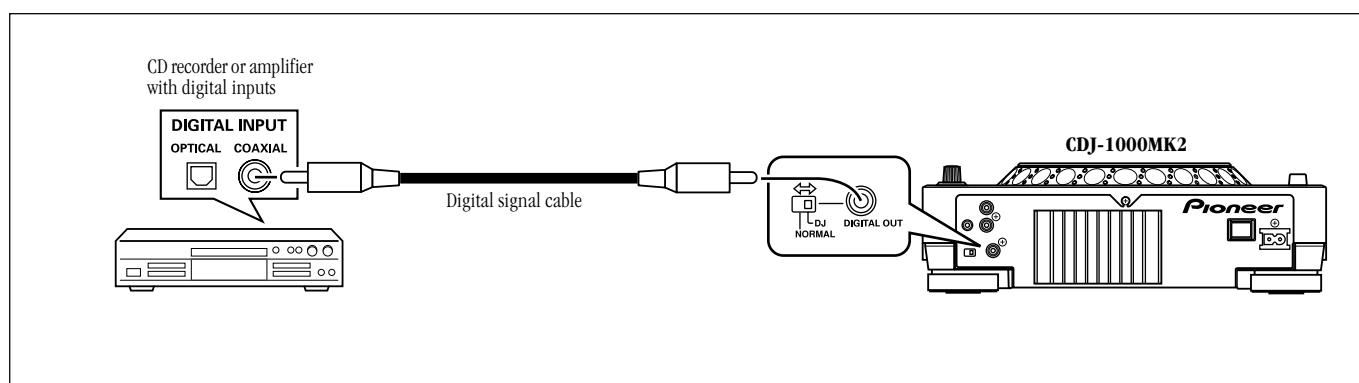

### ■ Setting the DIGITAL OUT Mode Switch (rear panel)

When the unit is used normally as a DJ CD Player, this switch should be set to DJ.

#### When set to DJ:

- The **DIGITAL OUT** connector outputs only audio data without sub-codes. The mode, however, is fixed at 44.1 kHz. Recording and other functions may be limited, depending on the type of CD recorder or other component connected. For details, consult the operating instructions for the component concerned.
- When **DIGITAL OUT** mode switch is first set to DJ, the display initially shows "**D-OUT**" then changes to "**DJ**."

#### When set to NORMAL:

- The **DIGITAL OUT** connector outputs digital data including sub-codes, but the unit's DJ functions are seriously restricted. (P. 9)
- When the **DIGITAL OUT** mode switch is set to NORMAL, the display initially shows "**D-OUT**" then changes to "**NORMAL**."
- If an unsupported operation is attempted, the display will first show "**D-OUT**" then change to display the "**NORMAL**" message.
- If the **DIGITAL OUT** mode switch has been set to NORMAL when the unit's power is switched on, the display will initially show "**D-OUT**," then change to display the "**NORMAL**" message.

#### NOTE:

When the **DIGITAL OUT** mode switch is set to NORMAL, the DJ functions (cue, loop, reloop, tempo adjust, hot cue, Jog dial and reverse playback) do not work. And the muted pause mode is used instead of the audible pause mode.

### 4. Connecting the power cord

When all connections have been made, connect the power cord to the AC inlet on the rear panel of the player and connect the power plug to an AC wall outlet or to a power receptacle on the rear panel of the amplifier.



## PANEL FACILITIES

## Top Panel

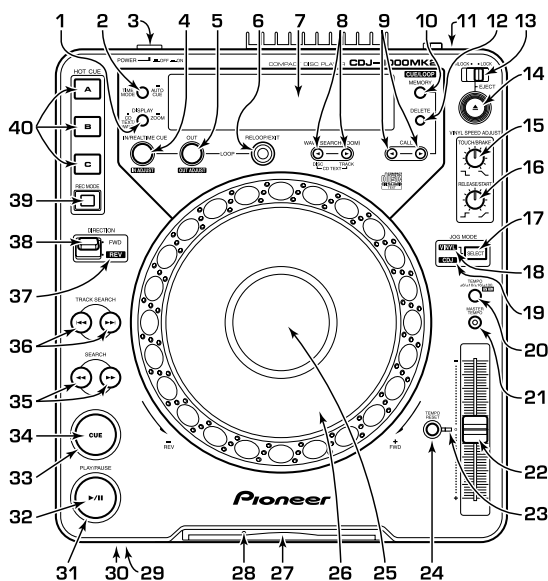

- 1 DISPLAY CD TEXT/WAVE (ZOOM) button (\*)**  
Each press of this button toggles the display between WAVE display and CD-TEXT disc/track title display. When the button is held down for 1 second or longer, the WAVE display cycles between the 1 track full-scale and 2x zoom scale.
- 2 TIME MODE/AUTO CUE button (\*)**  
**TIME MODE:**  
Each time this button is pressed, the time display changes between elapsed playback time and remaining playback time (REMAIN) of each track.
  - The **TIME MODE** is stored in memory and persists even when the power is turned off.**AUTO CUE:**  
Hold down this key for 1 second or longer to toggle between **AUTO CUE** on and off. ☞ P.11
  - **AUTO CUE** on/off status is stored in memory and persists even when the power is turned off.
- 3 POWER switch OFF /ON**   
This switch is located on the rear panel of the unit.
- 4 LOOP IN/REALTIME CUE/IN ADJUST button/indicator (\*)**  
Real-time cue ☞ P. 13  
Enter loop in point ☞ P. 14  
Loop in point adjust ☞ P. 14
- 5 LOOP OUT/OUT ADJUST button/indicator (\*)**  
Enter loop out point ☞ P. 14  
Loop out point adjust ☞ P. 14
- 6 RELOOP/EXIT button (\*) ☞ P. 15**
- 7 Display ☞ P. 10 .... 51–69**
- 8 WAVE SEARCH (ZOOM)/CD TEXT buttons (◀, ▶) (\*) ☞ P. 15**  
This button moves the displayed area when WAVE is in zoom display mode. In the TEXT display mode, pressing the ◀ button will display the disc title and pressing the ▶ button will display the track title.
- 9 CUE/LOOP CALL buttons (◀, ▶) (\*) ☞ P. 16**  
Calls Cue points and Loop points stored in internal memory or external memory (when a memory card is inserted). (When a memory card is inserted, the external memory takes precedence.)
- 10 CUE/LOOP MEMORY button (\*) ☞ P. 16**  
Stores Cue points and Loop points in internal memory or external memory (when a memory card is inserted). (When a memory card is inserted, the external memory takes precedence.)
- 11 DIGITAL OUT mode switch (DJ/NORMAL) ☞ P. 8**  
This switch is located on the unit's rear panel.  
When set to DJ, the DIGITAL OUT connector outputs audio data alone. When set to NORMAL, digital data (including sub-codes) is output, but the unit's DJ functions are not supported (operation buttons marked with the asterisk (\*) are disabled). No sound will be produced in the Pause mode.
- 12 CUE/LOOP DELETE button (\*) ☞ P. 16, 17**  
Deletes Cue points or Loop points stored in internal memory or external memory (when memory card is inserted). (When a memory card is inserted, the external memory takes precedence.)
- 13 EJECT UNLOCK/LOCK switch**  
**UNLOCK:** In this mode the disc can be ejected even during playback.  
**LOCK:** In this mode, the disc cannot be ejected during playback. The disc can be ejected when in pause mode.
- 14 EJECT button (▲)**  
When this button is pressed the disc is ejected through the disc insertion slot when it stops rotating. When the **EJECT UNLOCK/LOCK** switch is set to [LOCK] position, the disc can only be ejected when in pause mode.
- 15 VINYL SPEED ADJUST TOUCH/BRAKE dial (\*)**  
When the **JOG MODE SELECT** button is set to [VINYL] position, you can use this dial to adjust the speed by which the playback stops when the surface of the Jog dial is pressed.  
Playback stops faster as the dial is turned counterclockwise and stops slower as the dial is turned clockwise.
- 16 VINYL SPEED ADJUST RELEASE/START dial (\*)**  
When the **JOG MODE SELECT** button is set to [VINYL] position, you can use this dial to adjust the speed by which playback starts after you take your hand off the surface of the Jog dial. Playback starts normal speed faster as the dial is turned counterclockwise and takes longer time to return to normal speed when turned clockwise.
- 17 JOG MODE SELECT button (\*)**  
**VINYL mode:** when the surface of the Jog dial is pressed during playback, playback stops and if the dial is rotated, music is output according to the speed the dial is turned.
  - The **JOG MODE** is stored in memory and remains in memory even if the power is turned off.**CDJ mode:** above operation is not performed even when the Jog dial surface is pressed.
- 18 VINYL indicator (\*)**  
This indicator lights when the **JOG MODE** is in VINYL mode.
- 19 CDJ indicator (\*)**  
This indicator lights when the **JOG MODE** is in CDJ mode.
- 20 TEMPO Control Range button ±6/±10/±16/±100 WIDE (\*)**  
Each time the button is pressed, the range changes (±6%/±10%/±16%/±100%).
- 21 MASTER TEMPO button/indicator (\*) ☞ P.13**  
Each press of the button turns the master tempo function on or off.
- 22 Tempo Control knob (\*)**  
Slide the knob towards you (+) to increase the tempo and slide it away from you (–) to decrease it.
- 23 Tempo Reset indicator (\*)**  
Shows that the tempo has been reset to [0] (normal tempo) regardless of the position of the **Tempo Control** knob.
- 24 TEMPO RESET button (\*)**  
Resets the tempo to [0] (normal tempo) regardless of the position of the **Tempo Control** knob. Press button once more to release it.
- 25 Jog Dial Display ☞ P.10 .... 81–85**
- 26 Jog dial (+FWD/–REV) (\*) ☞ P.13**
- 27 Disc Loading Slot ☞ P.11**

## BEFORE OPERATIONS: PANEL FACILITIES

### 28 Force Ejection Hole P.5

### 29 Memory Card Loading Slot P.16

### 30 Memory Card indicator P.16

Lights when the MMC card is being accessed.

- Do not remove the card or turn off the power when this lamp is on.

### 31 Play/Pause indicator

Lights during play and flashes during pause.

### 32 PLAY/PAUSE button P.11

### 33 CUE indicator (\*) P.12

Lights when a Cue point is set and a search is not being performed. Flashes in pause mode.

### 34 CUE button (\*)

Cue point settings  P.12

Cue point sampler  P.13

Back cue  P.13

### 35 SEARCH button (, ) P.12

### 36 TRACK SEARCH button (, ) P.12

### 37 Reverse indicator (REV) (\*)

Lights when the DIRECTION FWD/REV switch is set to reverse.

### 38 DIRECTION FWD/REV switch (\*)

Plays tracks backwards when set to the [REV] position (forward position).

### 39 HOT CUE REC MODE button (\*) P.14

Switches HOT CUE button function (REC/CALL).

- It is set to call when the power is turned on.

### 40 HOT CUE A, B, C button/indicator P.14

It is set to hot cue point recording mode when A, B and C light in red.

It is set to call mode when A, B and C light in green. When the button is pressed, playback starts from the hot cue point. It is off when no hot cue point has been recorded.

## Display

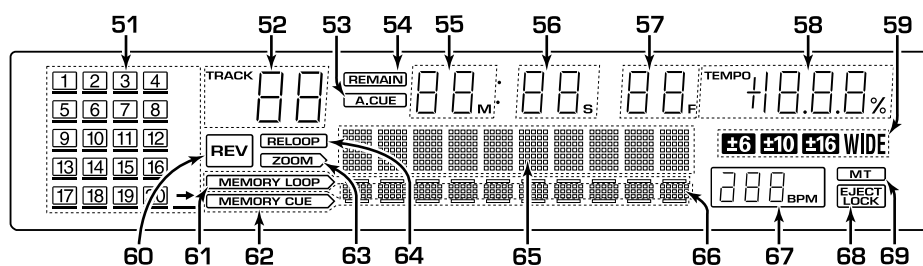

### 51 Calendar display ( - , )

TRACK numbers beyond the current track lights. When the next track is 21 or beyond,  lights. When Cue points or loops are stored, an underscore lights in the corresponding TRACK numbers.

### 52 TRACK Number indicator

Displays TRACK numbers.

### 53 Auto Cue indicator (A. CUE)

Lights when auto cue is on.

### 54 REMAIN indicator

Indicates that track remaining time is being displayed.

### 55 Time display (min) (M)

### 56 Time display (sec) (S)

### 57 Frame display (F)

One second is 75 frames.

### 58 Playback Tempo display (TEMPO)

Indicates the rate of change in the playback tempo.

### 59 Tempo Adjustment Range indicator (±6, ±10, ±16, WIDE)

Indicates the variable range of the Tempo Control knob selected with the TEMPO Control Range button. When ±100% is selected, the WIDE indicator appears in the display.

### 60 Reverse indicator (REV)

Indicates that the DIRECTION FWD/REV switch is set to reverse ([REV] position).

### 61 MEMORY LOOP indicator

Displays the selected track loop memory position above the playback address display (10 points). Even when there may be several memory points in the same block, only one lights.

### 62 MEMORY CUE indicator

Displays the selected cue memory positions under the playback address display (10 points). Even when there may be several memory points in the same block, only one lights.

### 63 ZOOM indicator

Indicates that WAVE is indicated in zoom mode.

### 64 RELOOP indicator

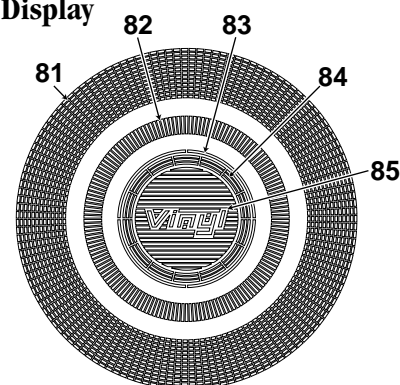

Lights when the unit is in reloop standby or performing a loop.

## Jog Dial Display



### 65 Wave/Text display

When WAVE is displayed the music level of the current track.

The level is indicated either in 1-track full scale, or zoom when only part of the track is shown. In the zoom mode, the display area is moved using the WAVE SEARCH (ZOOM) buttons (, ).

CD TEXT will be displayed in the TEXT mode.

The contents of the display is the disc title and track title in English up to a maximum of 48 letters which can be scrolled.

### 66 Playback Address display

Indicates elapsed playback time and remaining playback time in an easy to grasp 1-track full scale or 2x zoom scale bar graph.

- The 1-track full scale mode shows elapsed time by lit segments from the left.
- The 1-track full scale mode shows remaining time by unlit segments from the left.
- When the remaining time is 30 seconds or less, the display flashes gently and the flashing becomes faster when there is 15 seconds or less left.
- In the 2x zoom scale mode, only the playback position is lit for the WAVE display.

### 67 BPM Counter

Indicates BPM for the current track.

The BPM counter may sometimes not be able to measure the BPM of a track.

### 68 EJECT LOCK indicator

Lights when the EJECT UNLOCK/LOCK switch is set to the [LOCK] position.

### 69 Master Tempo indicator (MT)

Lights when the master tempo function is on.

### 81 Operation display

Indicates play position in frames 135 frames for one full rotation. Turns during playback and stops during pause.

### 82 Cue point position indicator

Indicates the current cue point position.

### 83 Display the condition of the audio memory

When set in the audio memory display mode the light will flash when recording.

### 84 Jog touch detection indicator

In the VINYL mode, this indicator lights when the surface of the Jog dial is pressed.

### 85 VINYL mode display.

Lights up in the VINYL mode.

## DISC LOADING/UNLOADING

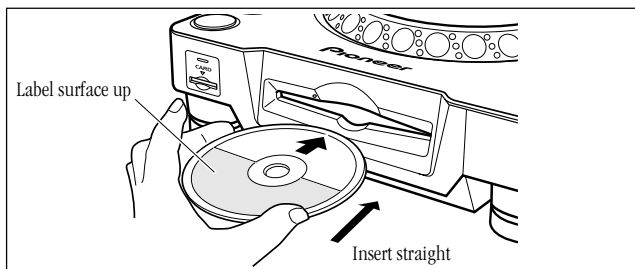

### 1. Set the rear-panel POWER switch to ON.

**Do not force a disc into the unit when the POWER switch is set to OFF as this may damage the disc and the unit.**

### 2. Insert a disc.

- Hold the disc with label surface upwards, and insert into the front panel disc loading slot.
- When playing 8cm discs, be sure to install an adaptor.

**This unit spins at high speed to provide high performance. When playing 8cm discs with an adaptor, for safety reasons the rotation speed is reduced as a result scratch and reverse speeds will be lower.**

- Only one disc can be loaded at a time. Never attempt to load more than one disc at the same time, or attempt to load a second disc when one disc has already been loaded.
- When loading a disc, do not place any twisting force on the disc, or try to force the disc into the slot. Also, do not attempt to interrupt or defeat the motion of the disc when the player begins to draw a disc into the slot or to eject a disc, since damage to the disc or player could occur.

3. The disc can be ejected anytime using the EJECT button (▲) when the EJECT UNLOCK/LOCK switch is set to UNLOCK. When the EJECT UNLOCK/LOCK switch is set to LOCK, press the PLAY/PAUSE button (▶/⏸) during playback, or when a Cue point has been set, press the CUE button (back cue) before pressing the EJECT button (▲) to eject the disc.

- When the EJECT button is pressed, disc rotation stops and the disc is ejected from the loading slot.
- If the disc cannot be ejected with the EJECT button, insert a pin in the forced ejection hole on the front panel of the player. ⇨ P. 5

#### CAUTION:

**Do not attempt to press a disc back into the slot when the [EJECT] indicator appears. Pressing a disc back into the slot while the [EJECT] indicator appears may cause the player to stop. In this case, press the EJECT button again and wait until the [EJECT] indicator goes out before reinserting the disc.**

#### PRECAUTIONS ON PLAYING CD SINGLES (8 cm/3-inch Discs)

- ① When playing CD singles (8 cm/3-inch discs), always use the adapter for 8 cm/3-inch discs. Before loading the disc into the CD player, be sure to check that it is secured properly by the catches of the adapter. If discs have been inserted without the adapter by mistake, remove the disc immediately by pressing the EJECT button. If the disc does not come out with one press, press another time.
- ② Use 8 cm/3-inch disc adapters labeled with the  mark (recommended standard product). Do not use adapters which cause the disc to idle, nor adapters which are bent or curved.

## DJ PLAYER OPERATION

Functions indicated with an asterisk (\*) are disabled when the rear panel DIGITAL OUT mode switch is set to NORMAL.

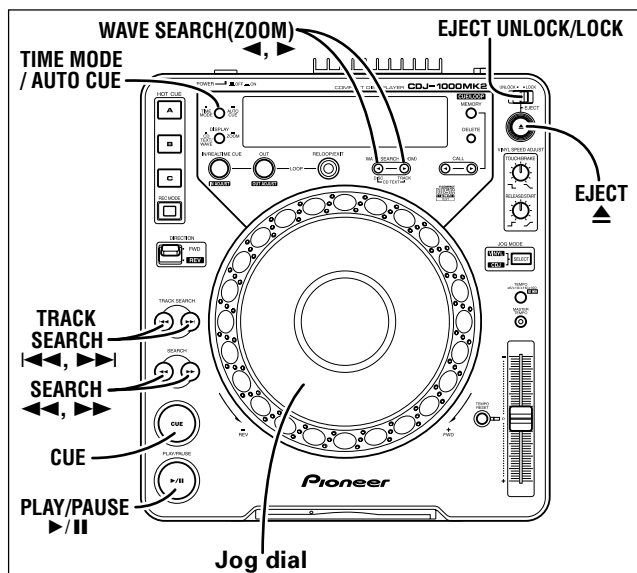

### Auto Cueing (\*)

When a disc is loaded, when track search is performed, and when the track is changed with the JOG MODE set to CDJ, this function operates to automatically set the cue point immediately before the actual start of music. ⇨ P. 12

#### ● Turning auto cueing on and off

Pressing the TIME MODE/AUTO CUE button and holding it down for a second or more causes auto cueing to be alternately turned on and off.

When AUTO CUE is on, the [A. CUE] indicator will be lit up.

- AUTO CUE on/off status is stored in memory and persists even when the power is turned off.

- It can change the Auto Cue level.

#### ■ Changing the Auto Cue level

1. Press the TIME MODE/AUTO CUE button for over 5 seconds.

- The display will indicate [A.CUE-60dB] (in the original state).

2. By -pressing the WAVE SEARCH (ZOOM) button (◀, ▶) you can change the level.

- It can choose from -36dB, -42dB, -48dB, -54dB, -60dB, -66dB, -72dB and -78dB.

- The level change mode can be removed if you press the TIME MODE/AUTO CUE button.

- Even if you turn the power off, the set level will remain in memory.

### Starting Playback

1. Insert a disc in the player.

This unit spins discs at high speeds to provide high performance. As a result, disc loading takes a couple of seconds.

2. If auto cueing is on, press the PLAY/PAUSE button (▶/⏸).

- Press the PLAY/PAUSE button only after the current time lights in the display. The silent portion at the beginning of the displayed track will be skipped and playback will begin instantaneously from the first bars of the track.

Once the first track has been played, the player will automatically search for the beginning of the next track to be played. The cueing indicator [CUE] will light up, the PLAY/PAUSE button [▶/⏸] indicator will flash, and the player will then wait for the PLAY/PAUSE button (▶/⏸) to be pressed before beginning playback of the next track.

## BASIC OPERATION: DJ PLAYER OPERATION

### 3. If auto cueing is off, playback will begin automatically from the first track.

- When auto cueing is off, playback will continue after the first track has been played, with all subsequent tracks being played in sequence.
- When playback of the final track is complete, playback will automatically come to an end.

#### Stopping Playback

Press the **EJECT** button (▲) when the **EJECT UNLOCK/LOCK** switch is set to **UNLOCK**.

When the **EJECT UNLOCK/LOCK** switch is set to **LOCK**, press the **PLAY/PAUSE** button (▶/⏸) during playback, or when a Cue point has been set, press the **CUE** button (back cue) before pressing the **EJECT** button (▲) to eject the disc.

- Playback will stop and the disc will be ejected.
- Note that the CDJ-1000MK2 does not come with a stop button.

#### To Pause Play

During playback, press the **PLAY/PAUSE** button (▶/⏸).

- The **PLAY/PAUSE** button's indicator and **[CUE]** indicator will flash, and play will be paused.
- When the **PLAY/PAUSE** button is pressed again, play will resume and the button indicator will light steadily.
- In the CDJ mode broken sound will still be audible during the standby mode; if you wish to stop all sound, lower the output sound volume on your audio mixer.
- When the unit has not been operated for 80 minutes or more in pause mode, the disc rotation stops automatically. In this instance, playback can be resumed by pressing the **PLAY/PAUSE** button.

#### Track Cueing

##### ■ TRACK SEARCH buttons (◀◀, ▶▶)

Press one of the **TRACK SEARCH** buttons (◀◀, ▶▶).

- Each time the button is pressed, the track is cued in the direction corresponding to the arrow on the button (during playback of one track, to cue playback to the beginning of the preceding track, press the ◀◀ button twice).
- When the button is pressed down and held, cueing is continuous. If the button is held for two seconds or more, the cue speed increases.
- Pressing the ◀◀ button twice at the beginning of the first track, will cause the unit to cue to the very last track.
- When the end of the disc's last track is reached, pressing the ▶▶ button will cue to the first track (track 1).

##### ■ Super-Fast Track Search

Rotate the **Jog dial** while pressing one of the **TRACK SEARCH** buttons (◀◀, ▶▶).

- While holding either one of the buttons depressed, rotate the dial in the direction corresponding to the direction you wish to skip; the unit will enter the high-speed skip mode.
- The direction of skip is in accordance with the direction in which the Jog dial is rotated. (the **TRACK SEARCH** button direction is released.)
- The high-speed skip mode is cancelled when the **TRACK SEARCH** button is released.

#### Fast-Forward / Fast-Reverse

##### ■ Operation using the SEARCH buttons (◀◀, ▶▶)

Press the **SEARCH** buttons (◀◀, ▶▶) during playback.

Press and hold the ▶▶ button to fast forward the disc; press and hold the ◀◀ button to do fast reverse.

##### ■ Super-Fast Search

Rotate the **Jog dial** while pressing one of the **SEARCH** buttons (◀◀, ▶▶)

- Hold down the button while turning the Jog dial in the direction you wish to search to enter fast forward or fast reverse mode.
- The direction of the search is determined by the direction the Jog dial is turned. The direction of the **SEARCH** button is ignored.

- When you stop turning the Jog dial, the unit returns to playback mode.
- Release the **SEARCH** button to exit this mode.

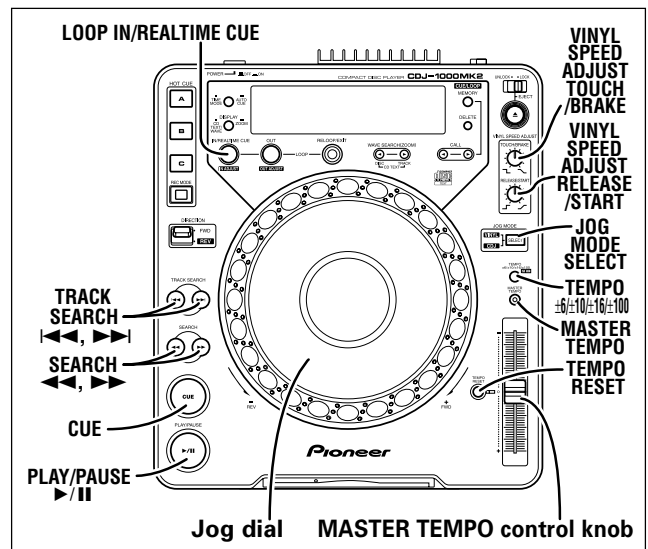

#### Cue Point Settings (\*)

Once a Cue point has been stored in memory, during playback it can be used to place the player in a state where it is ready to begin playback from the cueing position by pressing the **CUE** button.

##### ■ Setting the Cue point in the CDJ mode

1. During playback, press the **PLAY/PAUSE** button (▶/⏸) to pause playback at the point you wish to begin playback.
2. Search for the precise position of the Cue point.
  - Using frame numbers to specify Cue points.  
Cue points may be specified in 1-frame units (where 75 frames are equivalent to 1 second).  
Use the Jog dial or the forward or reverse **SEARCH** button (◀◀, ▶▶) to advance to the desired frame. Rotating the Jog dial once causes the player to advance or rewind 135 frames in the specified direction.
  - Listen to the sound at the current frame to determine the Cue point.  
Turn the Jog dial slowly and then return it to just before the point from which you wish to begin playback. (The cue point thus defined will consist of that point directly after the sound which can be heard during a cueing pause.)
3. Press the **CUE** button when you reach the desired frame number or hear the sound at the point from which you wish to begin cueing.
  - The sound will mute and the time will appear in the display, indicating that the cue point has been stored to memory.
  - Each time a new Cue point is stored to memory, the previous Cue point will be erased.

##### [Amending the Cue point]

1. During playback, press the **CUE** button.
  - This will take you back to the set track position.
2. Press one of the **SEARCH** buttons (◀◀, ▶▶) to set to audible pause mode.
3. In the CDJ mode, to set the Cue point, go through steps 2 and 3 as mentioned above.

##### ■ Setting the Cue point in the VINYL mode

1. During playback, at the point you wish to set as the cue point, either press and hold the surface of the Jog dial, or press the **PLAY/PAUSE** button (▶/⏸) to enter the standby mode.
2. While pressing the surface of the Jog dial, turn back the dial to a point just before the track you wish to play.
3. When the sound is the track you are searching for, press the **CUE** button while you are still pressing the surface of the Jog dial.
  - Cue point memory setting is completed when the current time lights in the display.
  - When a new Cue point is stored in memory the previous setting will be erased.

### [Amending the Cue point]

- 1. During playback, press the CUE button.**
  - This will take you back to the set track position.
- 2. In the VINYL mode, to set the Cue point, go through steps 2 and 3 as mentioned above.**
  - The **SEARCH** buttons (**◀◀**, **▶▶**) can now be used to modify the cue point, in the same way as for the CDJ mode.

#### ■ Real-time cue

**During playback, press the LOOP IN/REALTIME CUE button at the desired Cue point.**

- This point will then be recorded as the new Cue point.

#### ■ Checking cue points (Cue point sampler)

**After specifying a cueing point, press the CUE button.**

- The sound at the specified Cue point will continue to play as long as the **CUE** button is pressed.

#### ■ Returning to a Cue point (Back cue)

- 1. During playback, press the CUE button.**
  - The player will return to the specified Cue point.
- 2. Press the PLAY/PAUSE button (▶/II).**
  - Playback will begin immediately from the specified Cue point.

### Changing Playback Speed (\*)

**Pull the Tempo Control knob towards you.**

Slide the knob towards you (+) to increase the tempo and slide it away from you (-) to decrease it.

- The rate of change in playback speed (tempo) is shown in the display.
- The playback speed can be changed without changing the pitch (⇄ “Applying Master Tempo”).

#### ■ Selecting range of tempo adjustment

**Press the TEMPO ±6/±10/±16/±100 WIDE button.**

Each time the button is pressed the variable range of the **Tempo Control** knob changes as follows: ±6%, ±10%, ±16% and ±100%. You can adjust as follows: at ±6%:0.02%units, at ±10%:0.05%units, at ±16%:0.05%units, at ±100%:0.5%units.

- The set variable range value is indicated in the display. (When ±100% is selected, the **WIDE** indicator appears in the display.)

#### ■ Resetting tempo

**Press the TEMPO RESET button.**

The Tempo Reset indicator lights and the rate of tempo variation is reset to [0] (normal tempo) regardless of **Tempo Control** knob setting.

- One more press of the **TEMPO RESET** button cancels the reset and speed setting made with the **Tempo Control** knob is valid again.

### Applying Master Tempo (\*)

**Press the MASTER TEMPO button during playback.**

The **MASTER TEMPO** button and the [MT] indicator light. The speed (tempo) can now be changed using the **Tempo Control** knob but the pitch (key) does not change.

- Sound quality will be degraded when subjected to digital processing.

### Jog Dial Functions (\*)

- 1. Turning the Jog dial during playback (pitch bending)**  
(When the **JOG MODE SELECT** button is set to **VINYL**, touch the Jog dial side. The Jog dial operates differently when the surface of the Jog dial is pressed.)
  - In proportion to the amount of rotation, the playback speed is accelerated (FWD+) or decelerated (REV-). When in the reverse mode, the playback speed accelerates when the dial is rotated in the REV- direction, and decelerates when rotated in the FWD+ direction.
  - When rotation stops, the disc returns to normal speed.
- 2. Turning Jog dial during playback (scratch play)**  
(See page 14: Scratch Play)
- 3. Turning the Jog dial in pause mode (frame search)**  
(When **JOG MODE** is set to **CDJ**, the unit enters the audible pause mode, and when set to **VINYL**, the unit enters the ordinary muted pause mode (no audible sound); CD sound is played back at a speed corresponding to the speed with which the Jog dial is rotated.)
  - Searches can be performed in 1-frame increments.
  - When the CD is rotated once using the Jog dial, 1.8 seconds (135 frames) of music is played back.
- 4. During playback or turning in the pause condition (Spin)**  
Refer the [How to Spin] advanced operation.

- 5. During playback, rotate the Jog dial while holding the SEARCH button (◀◀, ▶▶) depressed. (Super-fast search)**  
Hold down the button while turning the Jog dial in the direction you wish to search to enter fast forward or fast reverse mode.
- 6. Rotate the Jog dial while holding the TRACK SEARCH button (◀◀, ▶▶) depressed. (Super-fast track search)**  
While holding the **TRACK SEARCH** button (◀◀, ▶▶) depressed, rotate the Jog dial in the direction in which you wish to perform track search; accelerated high-speed track search will begin in accordance with the direction and amount of rotation.

#### NOTE:

*The Jog dial contains a switch.*

*Do not put objects on the Jog dial or apply too much force.*

*Do not put drinks on the Jog dial as it may leak inside the dial and be the cause of a malfunction.*

### Mixing Different Tracks

(Example: Mix track B with currently playing track A from the main speakers.)

- Connect CD1 to the DJ mixer's CH 1, and connect CD 2 to CH 2.
- Raise the TRIM, CHANNEL FADER, and MASTER LEVEL settings appropriately so that sound is produced from CD1.

- 1. Set the DJ Mixer's CROSS FADER slider at its left side (CH 1).**
  - Track A is heard from speakers.
- 2. Load a CD on player CD2.**
- 3. Press the TRACK SEARCH buttons (◀◀, ▶▶) on player CD2 to find and select track B.**
- 4. Set the DJ Mixer's MONITOR SELECTOR button CH 2 to ON.**
- 5. Rotate the DJ Mixer's MONITOR LEVEL so that track B can be heard from the headphones.**
  - Only track A is heard from the main speakers.
- 6. Set cueing for track B on the headphones.**
  - With player CD2 in the playback mode, press the **PLAY/PAUSE** button (▶/II) to hear the point you wish to cue.
    - When the **JOG MODE** is set to **CDJ**, the unit will enter audible pause mode (sound can be heard); when set to **VINYL**, the unit will enter inaudible pause mode (no sound can be heard).
  - Rotate player CD2's Jog dial and search for the track's Cue point (first beat).
  - When you have settled on the Cue point, press the **CUE** button on player CD2.
    - The player's sound will be muted and cueing will be completed.
- 7. Simultaneously press player CD2's PLAY/PAUSE button (▶/II) when track A is heard from the speakers.**
  - Only track A will be heard from the main speakers.
  - Track B will be heard from the headphones.
- 8. Move the TEMPO slider to match the tempo (BPM=Beat Per Minutes) of tracks A and B.**  
Move the TEMPO slider of player CD2 so that the BPM of track B matches those of track A.
  - When the two BPM rates match, the BPM synchronization is complete.
- 9. Press the CUE button on player CD2.**
  - Player CD2 will enter pause mode at the Cue point.
- 10. As soon as track A is heard from the speakers, press the PLAY/PAUSE button (▶/II) on player CD2.**
  - Track B begins playing.
- 11. While checking the sound on the headphones, gradually move the DJ Mixer's CROSS FADER slider from left to right.**
  - The sound of track A from the speakers will steadily become mixed with the sound of track B.
  - When the DJ Mixer's **CROSS FADER** slider has moved all the way to the right side, the sound heard from the speaker will have changed from track A to track B, and the operation is complete.

#### ■ Long mix play

If the BPM rates match, mixing of tracks A and B will sound good even if the **CROSS FADER** slider is in the middle position.

## ADVANCED OPERATIONS

### ■ Fader start play

Using the cross fader start function of the DJM-600, DJM-500, DJM-300 or DJM-3000, step 10 above can be eliminated for even simpler mixing. In addition,

when the **CROSS FADER** slider is returned to its original position, the status returns to that in step 9 (player CD2 at its Cue point), so that you can repeat the same play as many times as you like.

## ADVANCED OPERATIONS

Functions indicated with an asterisk (\*) are disabled when the rear panel **DIGITAL OUT** mode switch is set to **NORMAL**.

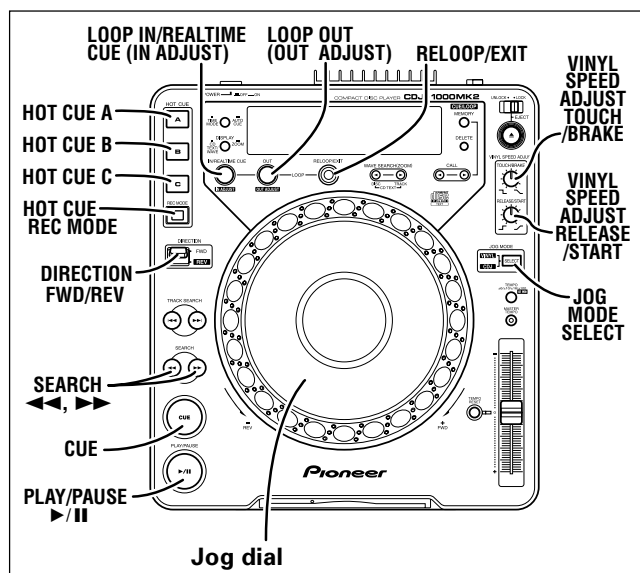

### Scratch Play (\*)

By changing from the **JOG MODE** to **VINYL**, and pressing and rotating the surface of the Jog dial you can replay according to the speed and direction of the Jog dial.

1. Press the **JOG MODE SELECT** button to light the **[VINYL]** indicator.
2. When replaying a CD press the surface of the Jog dial.
  - Playback slows down and stops (the slowdown in speed until the disc stops (response characteristics) can be set separately). By rotating the Jog dial when playback speed is decreasing but not yet stopped all sound will stop halfway through. See Step 3 for playback when rotating the Jog dial.
3. Turn the Jog dial in the direction and at the speed you wish to playback the disc.
  - The CD is played back according to the speed and direction of Jog dial movement.
4. Take your hand off the surface of the Jog dial.
  - The CD spins up or down to return to normal playback mode. (The slowdown or increase in speed until the CD returns to normal playback (response characteristics) can be set separately.)

### ■ Setting the time it takes for playback to slow down and stop when the Jog dial surface is pressed.

Turn the **VINYL SPEED ADJUST TOUCH/BRAKE** knob.

- This knob allows you to adjust the slowdown in speed (response characteristics) until CD playback stops.

### ■ After you have taken your hand off the surface of the Jog dial you can set the time it takes for the speed to return to the original condition of playback.

Turn the **VINYL SPEED ADJUST RELEASE/START** knob.

- This allows you to adjust the slowdown or increase in speed until the CD returns to normal playback (response characteristics).

### How to Spin (\*)

During playback in the **VINYL** mode either press the surface of the Jog dial or press the **PLAY/PAUSE** button (▶/⏸) to cause a pause, then quickly turn the Jog dial, even when released playback will occur according to the speed and direction of the dial.

### How to Brake (\*)

- When you press the **PLAY/PAUSE** button (▶/⏸) in the **VINYL** mode during playback, the **VINYL SPEED ADJUST TOUCH/BRAKE** button will cause a corresponding speed and the sound will stop.
- Upon pressing the **PLAY/PAUSE** button (▶/⏸) again playback will commence and the **VINYL SPEED ADJUST RELEASE/START** button will respond accordingly.

### Hot Cue (\*)

Provides instant start from any of three pre-selected hot cue points (A, B or C).

#### ■ Setting the hot cue point

1. Press the **HOT CUE REC MODE** button to light the **HOT CUE A, B and C** button indicators in red.
  - The pressed button flashes for 2 seconds in red.
  - The setting is automatically stored in the Multimedia Card (MMC). Ⓞ P.17
2. During playback or in pause mode, press the button (A, B or C) where you wish to store a hot cue point.
  - The pressed button flashes for 2 seconds in red.
  - The setting is automatically stored in the Multimedia Card (MMC). Ⓞ P.17

#### ■ Starting hot cue

1. Press the **HOT CUE REC MODE** button to light the **HOT CUE A, B and C** button indicators in green.
  - Buttons that do not store a hot cue point do not light.
2. During playback, in pause mode or cue standby, press the button (A, B or C) where you stored a hot cue point.
  - Playback starts from the stored hot cue point.
  - Loop play is cancelled.
  - Previously recorded hot cue points can be called from a Multimedia Card (MMC) when a CD is inserted. Ⓞ P.17

### Loop Playback (\*)

#### ■ Defining a loop

1. Press the **PLAY/PAUSE** button (▶/⏸) to begin playback.
2. During replay, press the **LOOP IN/REALTIME CUE** button at the loop in point.
  - Note that this operation need not be performed if a prerecorded Cue point is to be used as the start of the loop.
3. During playback, press the **LOOP OUT** button at the point from which you wish to end the loop.
  - Loop playback will begin, with playback looping from the loop start point to the loop end point.

#### ■ Stopping loop playback

During loop playback, press the **RELOOP/EXIT** button.

- Once this has been done, playback will continue in sequence from the loop end point without returning to the loop start point.

#### ■ Changing the loop in point

1. Press the **LOOP IN/REALTIME CUE (IN ADJUST)** button during playback.
  - The time of the in point is shown in the display, the **LOOP IN/REALTIME CUE** button starts to flash rapidly and the **LOOP OUT** button goes off.
2. Press the **SEARCH** button (◀◀, ▶▶) or turn the Jog dial.
  - In a 1 frame unit you can move the loop in point up to ±30 frames.
  - Press the **LOOP IN/REALTIME CUE** button or wait 30 seconds to leave editing mode and return to loop play.

**■ Changing the loop out point**

1. Press the **LOOP OUT (OUT ADJUST)** button in loop play.
  - The time of the out point is shown in the display, the **LOOP OUT** button starts to flash rapidly and the **LOOP IN/REALTIME CUE** button goes off.
2. Press the forward or reverse **SEARCH** button (◀◀, ▶▶) or turn the **Jog dial**.
  - The loop end point will be shifted forward or backward in 1-frame units.
  - The loop out point cannot be moved in front the loop in point.
  - Pressing the **LOOP OUT** button or waiting for 30 seconds or longer will cause the player to exit from update loop input point mode and to resume loop playback.

**■ Returning to loop playback (i.e., relooping)**

After loop playback has been stopped, press the **RELOOP/EXIT** button during playback to return to loop playback.

- The player will return to the currently defined loop start point and begin loop playback again from that point.

**Reversing Playback (\*)**

When the **DIRECTION FWD/REV** switch is set to the **[REV]** position (forward position) the **[REV]** indicator lights.

Tracks are played backwards.

- Due to Jog dial rotation increase and decrease playback speeds are reversed.
- During reverse playback, **CUE/LOOP** cannot be input, and **Re-Loop** and **HOT CUE** points cannot be set.
- Loops that are longer than 15 seconds cannot be played in the reverse mode.
- When performing track search, loop, etc, the audio memory display (Jog Dial Display) may flash and the **Scratch/Reverse** mode operation may not respond for 1-2 seconds.

**Fader Start Playback (\*)**

The supplied control cord may be used to connect the control jack on the **CDJ-1000MK2** to a control jack on a **DJM-600**, **DJM-500**, **DJM-300**, or **DJM-3000** mixer, thus making it possible to exit from cueing standby mode and to start playback immediately by raising the DJ mixer channel fader. The cross fader may also be used to perform fading starts on the player as well. The fader may also be returned to its original position to return the player to the cueing point (i.e., to perform back cueing).

(See page. 7 for instructions on how to connect the player.)

**Relay Play Using Two Players (\*)**

If you connect the terminals of this player with another **CDJ** series **CD** player using the supplied control cord then you will be able to relay play. P. 7.

- Set both player's auto cue function to **ON** (the **[A. CUE]** indicators will light in the displays).
  - Set your audio mixer's fader control to its center position.
1. **Begin playback on the first player.**
  2. **When the currently playing track ends, playback will begin automatically on the standby player.**
  3. **The first player will enter CUE standby mode at the beginning of the next track on its disc.**
    - By repeating this operation, the two players can be used to perform continuous relay play.
    - By loading new discs on the standby player, you can construct a continuous program of whatever tracks you wish.
    - By setting a Cue point on the standby player, you can perform relay to any desired Cue point on the selected track (see page 12: Cue Point Settings).

**NOTE:**

- Relay play may not operate properly if the audio out jacks on the two players are not connected to the same audio mixer.
- If the power to one player is turned off during its playback, the other player may begin playback.
- Fader start and relay play cannot be performed simultaneously, since different control cable connections are required.

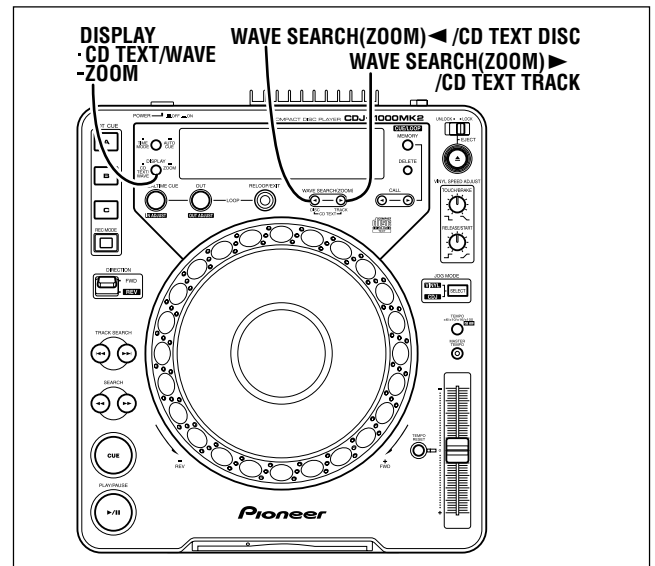

**Wave Display (\*)**

As the low pitch sounds (bass drum etc.) are shown in graph form you can learn of the break part or ending part of the track beforehand.

- When a piece of music changes it take a little while for all the **WAVE** displays to be indicated. If you store the **WAVE** display in a **Multimedia Card (MMC)**, then, from the next time, the **WAVE** display will be indicated immediately. P.17.
- When the low pitch sounds are few the break part may not be indicated on the display.
- When playing back a track with length exceeding 30 minutes, the **WAVE** display may not appear, depending on the speed of playback.

**■ Switch over to the WAVE display mode.**

You can choose between a full scale display of a piece to a double zoom scale display.

Press the **DISPLAY CD TEXT/WAVE (ZOOM)** button for over one second.

- You can switch over alternately from a one piece full scale display to a double zoom scale display.
- In the double zoom scale display mode, if you press the **WAVE SEARCH (ZOOM)** button (◀, ▶), you can shift the display part.

**About the CD TEXT (\*)**

**CDs** which have **CD TEXT** capability will show the disc title/track title up to a maximum of 48 letters and will scroll.

Track titles will be displayed in the **Track Search** mode.

Pressing the **CD TEXT DISC** button ◀ will display the disc title.

Pressing the **CD TEXT TRACK** button ▶ will display the track title.

## USING CUE POINTS/LOOP POINTS MEMORY

This unit can store Cue points and Loop points for each disc in internal or on a Multimedia Card (MMC).

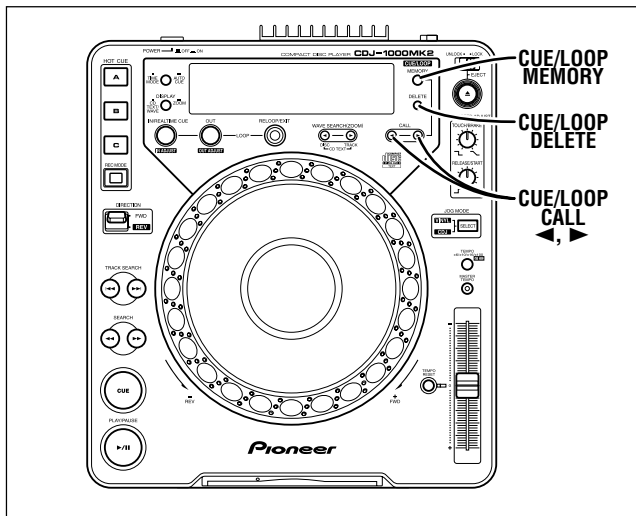

### Using Internal Memory

When a Multimedia Card (MMC) is not inserted in the card slot, the internal memory is used.

The internal memory can store 10 Cue and Loop points per disc and for a total of 100 discs. When the data exceeds 100 discs worth of data, data items are deleted starting from the oldest items.

- It takes 2 points (IN/OUT) for one loop.

#### ■ Storing Cue points

1. Enter Cue points using the **A. CUE** function or the **CUE** button.
2. Press the **CUE/LOOP MEMORY** button in Cue point standby mode (back Cue in play mode).
  - **[MEMORY]** is shown in the display indicating that the Cue point has been stored.
  - The Cue point lights in red in the calendar display and playback address display.

#### ■ Storing Loop points

1. Enter the Loop in/out points to perform loop playback.
2. Press the **CUE/LOOP MEMORY** button during loop playback.
  - **[MEMORY]** is shown in the display indicating that the Loop in/out points have been stored.
  - The Loop in point lights in red in the calendar display and playback address display.

#### ■ Calling stored Cue/Loop points

When Cue/Loop points are stored, the calendar display and the playback address display lights in red.

1. Press the **CUE/LOOP CALL** button.
  - When the **CALL** button (▶) is pressed, Cue/Loop points are called in order from the beginning of the disc and the disc is set to standby at the Cue/Loop in point.
2. Press the **PLAY/PAUSE** button (▶/||).
  - Play or loop play starts.

#### ■ Deleting stored Cue/Loop points

When Cue/Loop points are stored, the calendar display and the playback address display lights in red.

1. Press the **CUE/LOOP CALL** button.
  - When the **CALL** button (▶) is pressed, Cue/Loop points are called in order from the beginning of the disc and the disc is set to standby at the cue or loop in point.
2. Press the **CUE/LOOP DELETE** button when in standby mode at the called point.
  - **[DELETE]** is shown in the display indicating that the Cue/Loop points have been deleted.
  - The Cue/Loop in point indication in the calendar display and the playback address display go off.

### Using a Multimedia Card

When a Multimedia Card is inserted in the card insertion slot, the external memory (MMC) takes precedence. For each disc, 100 CUE/LOOP points, 3 hot start points, and 20 WAVE tracks can be recorded. An 8Mb MMC can record data for 5,000 discs, and a 16Mb MMC can record data for 10,000 discs. Using MMCs with capacity above 16Mb will not result in greater disc data storage, however (maximum data recordable is for 10,000 discs).

- It takes 2 points (IN/OUT) for one loop.

#### ■ Insert Multimedia Cards

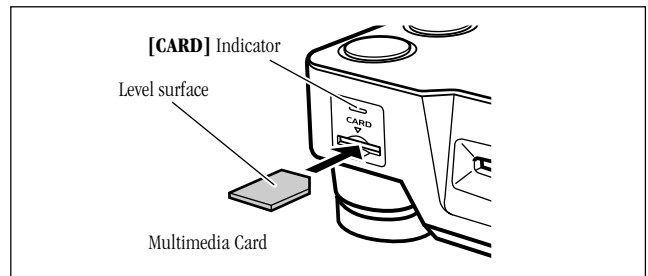

Insert Multimedia Cards horizontally with the flat surface up and the notch facing to the right. Push the card gently into the slot until it is seated.

#### ● Removing Multimedia Cards

Confirm the **[CARD]** indicator is off, press the card in the slot once, wait for it to be ejected and gently pull it out.

#### NOTE:

- The **[CARD]** indicator is on when the card is being accessed. Do not remove the card or turn off the power when this indicator is on. (Otherwise the data may be corrupted.)
- **[MMC I/O Err]** shows when you insert the Multimedia Card, then take the card out and try to insert it once more.
- The Multimedia Card is a precision electronic instrument. Do not bend it, apply force or shock or drop it. Do not use or keep it in a place that is subject to static electricity or electric noise.
- Multimedia cards may be damaged when subjected to shock or static electricity. Care is needed in their handling. It is recommended that periodical copies be made of important data. ☞ P. 17

#### ■ Using a Multimedia Card for the first time

A Multimedia Card that is used for the first time must be formatted.

1. Insert the Multimedia Card (MMC) in the card insertion slot.
  - **[FORMAT?PUSH MEMORY]** is displayed.
2. Press the **MEMORY** button when the disc is to be formatted.
  - **[FORMAT]** is displayed and formatting starts.
  - Remove the card if it is not to be formatted.
  - Formatting a card deletes any data previously recorded on it.



■ **Storing CUE points**

Insert a Multimedia Card in the card insertion slot and perform the same procedure as when the internal memory is used. ⇨ P.16

■ **Storing Loop points**

Insert a Multimedia Card in the card insertion slot and perform the same procedure as when the internal memory is used. ⇨ P.16

■ **Calling stored Cue/Loop points**

Insert a Multimedia Card in the card insertion slot and perform the same procedure as when the internal memory is used. ⇨ P.16

■ **Deleting stored Cue/Loop points**

Insert a Multimedia Card in the card insertion slot and perform the same procedure as when the internal memory is used. ⇨ P.16

■ **Deleting data from a specific disc**

Deleting data from the memory card of a specific disc.

**1. Insert the disc.**

- Insert the disc from which to delete Cue/Loop points etc. from the memory card.

**2. Insert the Multimedia Card (MMC) in the card insertion slot.**

- When Cue and Loop points are stored, the calendar display and the playback address display lights in red.

**3. Hold down the CUE/LOOP DELETE button for 5 seconds or longer.**

- [DISC DELETE? PUSH MEMORY] is displayed on the display.

**4. Press the CUE/LOOP MEMORY button.**

- With [DELETE] shown on the display, that disc's Cue/Loop points etc will be deleted from the memory card.
- All the lights of the calendar display and the Cue/Loop display etc. of the playback positioning display will go out.

■ **Formatting cards**

Formatting deletes all data on the MMC.

**1. Removing the disc.**

**2. Insert the Multimedia Card (MMC) in the card insertion slot.**

**3. Hold down the CUE/LOOP DELETE button for 5 seconds or longer.**

- [FORMAT? PUSH MEMORY] is displayed.

**4. Press the CUE/LOOP MEMORY button.**

- [FORMAT] is displayed and all data on the card is deleted.

■ **Data other than CUE/LOOP stored on MMC**

● **Hot cue points A, B, C**

Hot cue points A, B and C are automatically stored on MMC. When a disc storing hot cue points is inserted, the [A], [B] and [C] indicators light in green. To call stored hot cue points, press the **A**, **B** or **C** button.

The green flashing indicator will light steadily (when the call is made, sound will be interrupted briefly). If call is not needed, press the **HOT CUE REC MODE** button. The indicator will change to red, and you can set the hot cue point. To call the hot cue point, remove and replace the disc or MMC and the **A**, **B** and **C** buttons will blink on and off, at this time it is possible to call.

● **WAVE display**

When a wave display for one track is completed it is automatically stored on the MMC. When the same track is played again, the stored WAVE display is automatically called. Data for items beyond track number 21 are stored on the MMC.

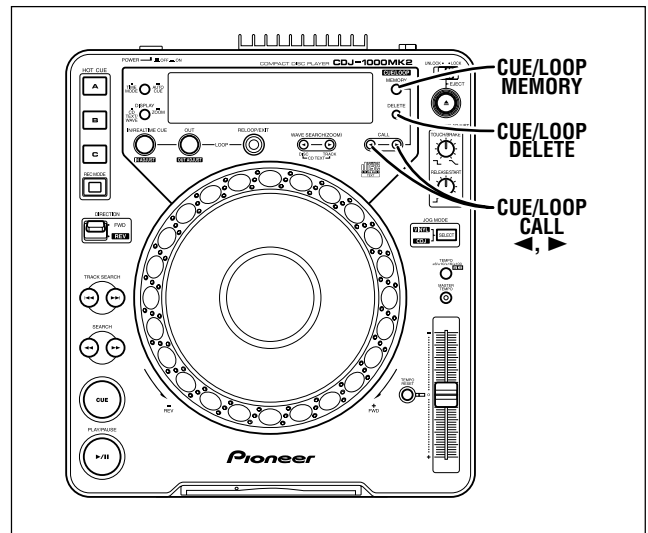

**Copying MMC Data (From One MMC to Another)**

Use the following procedure to copy data on one MMC (CARD A) to another MMC (CARD B).

**1. Remove the disc.**

**2. Remove the card.**

**3. Hold down the CUE/LOOP MEMORY button for 5 seconds or longer.**

- [MMC>MMC(OVERWRITE), CARD A IN] is displayed.

**4. Insert the MMC to copy data from in the card insertion slot.**

- [READING] is displayed.

**5. After a few minutes, [CARD B IN] is displayed. Remove card A and insert the destination card (CARD B) in the insertion slot.**

- [WRITING] is displayed.

**6. After a few minutes [CARD A IN] is displayed.**

**7. Repeat steps 4 to 6 twice for a 8M card and four times for a 16M card to complete the copy operation.**

- [COMPLETE] is displayed when copying is completed.

It is impossible to copy from a card with greater capacity to the receiving card.

**Copying Data in the Internal Memory (Copying from internal memory onto MMC)**

This procedure copies data in internal memory to MMC.

**1. Remove the disc.**

**2. Remove the card.**

**3. Hold down the CUE/LOOP MEMORY button for 5 seconds or longer.**

- [MMC>MMC(OVERWRITE), CARD A IN] is displayed.

**4. Press the CUE/LOOP MEMORY button again.**

- [INT>MMC(OVERWRITE), CARD IN] is displayed.

**5. Insert the destination MMC.**

- [WRITING] is displayed.

- [COMPLETE] is displayed when copying is completed.

\* *If the [Err] message appears in one of the displays, the memory data has not been copied properly. Turn the power to both players OFF and then ON again, and repeat the copying procedure from step 1.*

\* *When copying from MMC to MMC, or from internal memory to MMC, the MMC memory is overwritten; as a result, any data previously recorded in MMC will be completely erased.*

\* *Perform this procedure with the DIGITAL OUT mode set to "DJ".*

## TROUBLESHOOTING

Incorrect operations can be mistaken as malfunctions. If you believe the unit is not operating correctly, consult the chart below. Sometimes incorrect operation may be due to a malfunction in another component. If the problem is not fixed, check the other components used with the player. If the problem still persists, contact your nearest Pioneer authorized service center or dealer for service.

Symptom	Cause	Remedy
Disc doesn't eject even when <b>EJECT</b> button (▲) is pressed.	<ul style="list-style-type: none"> <li>Power plug is disconnected from outlet.</li> <li>The <b>EJECT UNLOCK/LOCK</b> button is set to the [LOCK] position.</li> </ul>	<ul style="list-style-type: none"> <li>Connect plug to wall outlet.</li> <li>Go to pause mode or cue standby mode before pressing the <b>EJECT</b> button (▲).</li> <li>Set the <b>EJECT UNLOCK/LOCK</b> button to the [UNLOCK] position before pressing the <b>EJECT</b> button (▲).</li> </ul>
Play doesn't commence even when the disc is inserted.	<ul style="list-style-type: none"> <li>The auto cue function is set to on.</li> </ul>	<ul style="list-style-type: none"> <li>Hold down the <b>TIME MODE/AUTO CUE</b> button for 1 second or longer to turn off the <b>A. CUE</b> function.</li> </ul>
Playback immediately stops when started. During playback, the player pauses or stops.	<ul style="list-style-type: none"> <li>Disc is loaded upside down.</li> <li>Smudges on the disc, etc.</li> </ul>	<ul style="list-style-type: none"> <li>Load the disc correctly with the label side UP.</li> <li>Clean the smudges from the disc and then play it again.</li> </ul>
No sound is audible.	<ul style="list-style-type: none"> <li>Output cables are connected incorrectly or are loose.</li> <li>Incorrect operation of audio mixer.</li> <li>Pin plugs and/or amplifier terminals are dirty.</li> <li>Player is in pause mode.</li> </ul>	<ul style="list-style-type: none"> <li>Recheck connections. Refer to installation instructions.</li> <li>Check the settings of the audio mixer switches and sound volume controls.</li> <li>Clean away dirt.</li> <li>Press the <b>PLAY/PAUSE</b> button (▶/⏸).</li> </ul>
Sound is distorted, noise is output.	<ul style="list-style-type: none"> <li>Incorrect connections.</li> <li>Pin plugs and/or amplifier terminals are dirty.</li> <li>Interference is being picked up from a TV set.</li> </ul>	<ul style="list-style-type: none"> <li>Connect to audio mixer's LINE INPUT terminals. (Do not connect to MIC terminals.)</li> <li>Clean away dirt.</li> <li>Switch OFF TV set, move player away from TV set or plug the player into a separate outlet.</li> </ul>
With certain discs, loud noise is produced or play stops.	<ul style="list-style-type: none"> <li>Disc has a bad scratch or warp.</li> <li>Disc is extremely dirty.</li> </ul>	<ul style="list-style-type: none"> <li>Replace disc.</li> <li>Clean disc.</li> </ul>
When the auto cue function is set ON, track search is not finished.	<ul style="list-style-type: none"> <li>If the sound muted portion between selections is long, searching time will be long.</li> <li>If the sound muted portion is recorded for about 10 seconds or more, playback will start without the auto cue function.</li> </ul>	<ul style="list-style-type: none"> <li>Press <b>TIME MODE/AUTO CUE</b> button for more than 1 second to set the auto cue function OFF.</li> </ul>
Back cue function cannot be carried out even though the <b>CUE</b> button is pressed in playback mode.	<ul style="list-style-type: none"> <li>The Cue point is not set yet.</li> <li>The <b>DIGITAL OUT</b> mode switch is set to the [NORMAL] position.</li> </ul>	<ul style="list-style-type: none"> <li>Set the Cue point. (See page 12.)</li> <li>The <b>DIGITAL OUT</b> mode switch is set to the [DJ] position.</li> </ul>
Pressing the <b>LOOP OUT</b> button does not start loop play.	<ul style="list-style-type: none"> <li>No Cue points (start points) have been set.</li> <li>The <b>DIGITAL OUT</b> mode switch is set to the [NORMAL] position.</li> </ul>	<ul style="list-style-type: none"> <li>Set a Cue point.</li> <li>The <b>DIGITAL OUT</b> mode switch is set to the [DJ] position.</li> </ul>
The Jog dial does not operate. The Jog dial does not operate as desired.	<ul style="list-style-type: none"> <li>The <b>DIGITAL OUT</b> mode switch is set to the [NORMAL] position.</li> <li>Incorrect <b>JOG MODE [VINYL/CDJ]</b> is set.</li> </ul>	<ul style="list-style-type: none"> <li>The <b>DIGITAL OUT</b> mode switch is set to the [DJ] position.</li> <li>Press the <b>JOG MODE SELECT</b> button to set the desired <b>JOG MODE [VINYL or CDJ]</b>.</li> </ul>
DJ functions do not work.	<ul style="list-style-type: none"> <li>The <b>DIGITAL OUT</b> mode switch is set to the [NORMAL] position.</li> </ul>	<ul style="list-style-type: none"> <li>The <b>DIGITAL OUT</b> mode switch is set to the [DJ] position.</li> </ul>
The picture of the TV screen is fluctuated or FM broadcast is interfered with noise.	<ul style="list-style-type: none"> <li>Interference is being picked up from the CD player.</li> </ul>	<ul style="list-style-type: none"> <li>Turn off <b>POWER</b> switch of the player, or move the player away from the TV or tuner.</li> </ul>
The disc is not rotating when power is ON.	<ul style="list-style-type: none"> <li>The disc rotation stops automatically if no operation has been performed for 80 minutes or more in pause mode</li> <li>When the last track on the disc is over the disc stops rotating.</li> </ul>	<ul style="list-style-type: none"> <li>Playback can be started by pressing the <b>PLAY/PAUSE</b> button (▶/⏸). Press the <b>EJECT</b> button (▲) to eject the disc.</li> </ul>

- Static electricity and other external effects may cause this unit to malfunction. In this case, set the **POWER** switch to OFF, then switch it on again after the disc has come to a complete stop.
- This unit cannot playback unfinalized (partial discs) CD-R or CD-RW discs.
- This component is designed to play 12cm discs and 8cm discs with a commercially available adaptor, eccentrically shaped discs cannot be played since damage or malfunction may result.
- When using an 8cm disc with an adaptor, compared to a 12cm disc, the speed may be slower in the scratch and reverse modes etc. This component rotates at a very high speed to generate high performance, however, in the interest of safety, the speed is lowered when an 8cm disc and adaptor are used. This is NOT a malfunction.
- The BPM value measured by the CDJ-1000MK2 may differ from the BPM value recorded on a CD or from our DJ mixer, but this difference is a result of differences in the BPM value measurement method; not a result of a fault with the player.
- When using CD-R/RW discs, performance may be degraded depending on the quality of the recording.

### About Data Recorded on MultiMedia Cards (MMC)

**Users are responsible for preserving the data on their MultiMedia Cards; it is recommended that users make periodic backups of all important data stored on their cards.**

**It is not the responsibility of PIONEER if the component or MMC malfunctions due to outside interference of static electricity etc. and if data on the MMC is damaged or lost or incidental damage occurs no indemnification will be made.**

### Error message display

When the CDJ-1000MK2 CD player is unable to operate properly, an error code is displayed on the display panel. Check the error code displayed against the following table and take the recommended action to correct the error. If an error code other than any of the error codes listed in the table below is displayed or if the same error code is displayed even after corrective action has been taken, contact your nearest Pioneer Service Station or contact the store from which you purchased your player for assistance.

Error Code	Error Type	Description	Possible cause and recommended action
E-72 01	TOC READ ERROR	Player unable to read TOC data.	Disc is cracked. → Recommended action: replace disc.
E-83 01 E-83 02 E-83 03	PLAYER ERROR	Disc is rotating, but rotation cannot be ascertained. Player unable to play back currently inserted disc.	Disc is soiled or dirty. → Recommended action: clean disc. If other discs play normally, the problem is with the disc itself.
E-91 01	MECHANICAL TIME OUT	Mechanical operation has failed to complete within specified time interval.	Dust or some other form of foreign particles have found their way into disc insertion slot. → Recommended action: remove dust or other foreign particles.

### Cleaning the Jog Dial

To clean the PLAYER wipe with a polishing or a soft, dry cloth. For stubborn dirt, moisten a soft cloth with a weak solution of neutral detergent (diluted in five to six parts water), wring the cloth well, and wipe away the dirt. Use a dry cloth to wipe the surface dry. Applying alcohol, paint thinner, benzene, insecticides, or other stringent substances to the Jog dial may cause the markings or finishing of the dial to peel or become discolored, and the use of any such substances should accordingly be avoided.

Should this product require service in the U.S.A. and you wish to locate the nearest Pioneer Authorized Independent Service Company, or if you wish to purchase replacement parts, operating instructions, service manuals, or accessories, please call the number shown below.

**800 – 782 – 7210**

Please do not ship your product to Pioneer without first calling the Customer Support Division at the above listed number for assistance.

**Pioneer Electronics (USA) Inc.  
Customer Support Division  
P.O. BOX 1760, Long Beach,  
CA 90801-1760, U.S.A.**

For warranty information please see the Limited Warranty sheet included with your product.

Should this product require service in Canada, please contact a Pioneer Canadian Authorized Dealer to locate the nearest Pioneer Authorized Service Company in Canada. Alternatively, please contact the Customer Service Department at the following address:

**Pioneer Electronics of Canada, Inc.  
Customer Satisfaction Department**

**300 Allstate Parkway  
Markham, Ontario L3R 0P2  
(905) 479-4411  
1 (877) 283-5901**

For warranty information please see the Limited Warranty sheet included with your product.

**SPECIFICATIONS**

**1. General**

System ..... Compact disc digital audio system  
 Power requirements ..... AC 120 V, 60 Hz  
 Power consumption ..... 33 W  
 Operating temperature ..... +5 °C – +35 °C  
 Operating humidity ..... 5% – 85%  
 (There should be no condensation of moisture.)  
 Weight ..... 4.2 kg (9.26 lb)  
 Dimensions ..... 320 (W) × 370 (D) × 105 (H) mm  
 12 – 5/8 (W) × 14 – 9/16 (D) × 4 – 1/8 (H) in

**2. Audio section**

Frequency response ..... 4 Hz – 20 kHz  
 Signal-to-noise ratio ..... 115 dB or more (JEITA)  
 Distortion ..... 0.006% (JEITA)

**3. Accessories**

- Operating instructions ..... 1
- Power cord ..... 1
- Audio cable ..... 1
- Control cord ..... 1
- Forced eject pin (housed in a groove in the bottom panel) ..... 1
- Multimedia Card (MMC) (16 MB) ..... 1
- Limited warranty ..... 1

**NOTE:**

*Specifications and design are subject to possible modification without notice.*



*Dear Customer:*

Selecting fine audio equipment such as the unit you've just purchased is only the start of your musical enjoyment. Now it's time to consider how you can maximize the fun and excitement your equipment offers. This manufacturer and the Electronic Industries Association's Consumer Electronics Group want you to get the most out of your equipment by playing it at a safe level. One that lets the sound come through loud and clear without annoying blaring or distortion-and, most importantly, without affecting your sensitive hearing.

Sound can be deceiving. Over time your hearing "comfort level" adapts to higher volumes of sound. So what sounds "normal" can actually be loud and harmful to your hearing. Guard against this by setting your equipment at a safe level BEFORE your hearing adapts.

**To establish a safe level:**

- Start your volume control at a low setting.
- Slowly increase the sound until you can hear it comfortably and clearly, and without distortion.

**Once you have established a comfortable sound level:**

- Set the dial and leave it there.

Taking a minute to do this now will help to prevent hearing damage or loss in the future. After all, we want you listening for a lifetime.

**We Want You Listening For A Lifetime**

Used wisely, your new sound equipment will provide a lifetime of fun and enjoyment. Since hearing damage from loud noise is often undetectable until it is too late, this manufacturer and the Electronic Industries Association's Consumer Electronics Group recommend you avoid prolonged exposure to excessive noise. This list of sound levels is included for your protection.

**Decibel**

Level	Example
30	Quiet library, soft whispers
40	Living room, refrigerator, bedroom away from traffic
50	Light traffic, normal conversation, quiet office
60	Air conditioner at 20 feet, sewing machine
70	Vacuum cleaner, hair dryer, noisy restaurant
80	Average city traffic, garbage disposals, alarm clock at two feet.

**THE FOLLOWING NOISES CAN BE DANGEROUS UNDER CONSTANT EXPOSURE**

90	Subway, motorcycle, truck traffic, lawn mower
100	Garbage truck, chain saw, pneumatic drill
120	Rock band concert in front of speakers, thunderclap
140	Gunshot blast, jet plane
180	Rocket launching pad

Information courtesy of the Deafness Research Foundation.



S001 En

Published by Pioneer Corporation.  
 Copyright © 2003 Pioneer Corporation.  
 All rights reserved.

**PIONEER CORPORATION**

4-1, Meguro 1-Chome, Meguro-ku, Tokyo 153-8654, Japan

**PIONEER ELECTRONICS (USA) INC.**

**Multimedia and Mass Storage Division:** 2265 East 220th Street, Long Beach, CA 90810, U.S.A. TEL: 800-444-OPT1 (6784)

**PIONEER ELECTRONICS OF CANADA, INC.**

**Industrial Products Department:** 300 Allstate Parkway, Markham, Ontario L3R 0P2, Canada TEL: 905-479-4411

## Free Manuals Download Website

<http://myh66.com>

<http://usermanuals.us>

<http://www.somanuals.com>

<http://www.4manuals.cc>

<http://www.manual-lib.com>

<http://www.404manual.com>

<http://www.luxmanual.com>

<http://aubethermostatmanual.com>

Golf course search by state

<http://golfingnear.com>

Email search by domain

<http://emailbydomain.com>

Auto manuals search

<http://auto.somanuals.com>

TV manuals search

<http://tv.somanuals.com>