

TECHNICAL MANUAL (Ver. 2.0)

PLASMA DISPLAY MONITOR: PDP-502MX

TABLE-TOP STAND: PDK-5001

PLASMA DISPLAY CEILING SUSPENSION HARDWARE: PDK-5002

PDP BRACKET: PDK-5005

PLASMA DISPLAY WALL-MOUNT HARDWARE: PDK-5006

CARRIABLE STAND: PDK-5008

SPEAKER SYSTEM: PDP-S03-LR

This manual provides precautions and information for installation, preparation, and handling of the plasma display and its dedicated mounting hardware.

Before installation and preparatory work, choose a safe and appropriate site after thorough consideration of construction, materials used, strength, and surroundings. If adequate safeguards are not in place, immediately halt the installation process and discontinue marketing activities.

CAUTION



Exclamation marks placed within triangles are intended to alert users to the presence of important safety information. Be sure to read instructions indicated by this symbol.

PRECAUTIONS:

- We accept no responsibility for losses resulting from the use of parts other than those supplied by us.
- We guarantee the performance of our products only when they are assembled and adjusted as described in this manual.
- The specifications and external designs shown in this manual are subject to change without notice.

ABOUT MOUNTING/INSTALLATION

- This product is sold under the assumption that installation will be performed by experienced, qualified experts. Refer all mounting and installation work to qualified personnel, or consult the nearest PIONEER dealer for assistance.
- We accept no responsibility for accident or loss resulting from failure to select an appropriate installation site, or for those occurring during assembly, installation, mounting, or operation of this product, or resulting from modifications made to this product, or from natural disasters.

Pioneer

Table of Contents

FEATURES	4
SPECIFICATIONS	
2.1 Specifications	6
2.2 External Dimensions	8
2.3 Controls and Connectors	10
2.4 Pin layout	12
2.5 Remote Control Unit	13
2.6 Remote Control Unit Case	14
INSTALLATION SITE REQUIREMENTS	
3.1 Installation Site Requirements	16
3.2 Installation Conditions	18
3.2.1 Heat dissipation	18
3.2.2 Calculating heat quantity	19
3.2.3 Product mounting holes	19
3.2.4 Mounting surface warping	21
3.3 Installation Procedures	22
3.3.1 Transportation precautions	22
3.3.2 Unpacking	22
3.3.3 Mounting on the attachment stands	23
3.3.4 Re-packing	23
3.3.5 Wiring	24
3.4 Special Installation	26
3.4.1 Mounting to fittings	26
3.4.2 Hanging on the wall	28
3.4.3 Embedding in the wall	30
3.4.4 When the display is put in a box	34
3.4.5 Ceiling suspension (with wires)	36
3.4.6 Hanging on the wall (lengthwise)	38
3.4.7 Place product upright and flush into wall (embedding in the wall)	40
3.4.8 Horizontal connections	44
3.4.9 Multiple	46
HOW TO USE THE STANDARD MOUNTING COMPONENTS	
4.1 Standard Mounting Components Features and Characteristics	47
4.2 Handling the Standard Mounting Components	48
4.2.1 Handling precautions	48
4.2.2 Precautions for installation contractors	48
4.3 Installation of the Attachment Stand	49
4.4 Table-top Stand: PDK-5001	51
4.4.1 Specifications	51
4.4.2 Mount locations for floor-fastening screws	52
4.4.3 Dimensions	52
4.4.4 Assembling the stand	53
4.4.5 Mounting to the main unit	54
4.5 Plasma Display Ceiling Suspension Hardware (one-side type): PDK-5002	55
4.5.1 Specifications	55
4.5.2 External Dimensions	56
4.5.3 Assembling and Installing the mounting hardware and mounting the plasma display	57
4.6 PDP Bracket: PDK-5005	61
4.6.1 Specifications	61
4.6.2 External Dimensions	62
4.6.3 Assembly Procedure	63
4.6.4 An example of use	64
4.7 Tiltable Plasma Display Wall-Mount Hardware: PDK-5006	65
4.7.1 Specifications	65
4.7.2 External Dimensions	66
4.7.3 Assembling the mounting hardware and mounting the plasma display	67
4.8 Carriable Stand: PDK-5008	71
4.8.1 Specifications	71
4.8.2 External Dimensions (with plasma display monitor PDP-502MX mounted)	72
4.8.3 Mounting procedures	73
4.9 Speaker System: PDP-S03-LR	75
4.9.1 Specifications	75
4.9.2 External Dimensions (with plasma display monitor PDP-502MX mounted)	75
4.9.3 Mounting to the main unit	76
4.9.4 Mounting with the plasma display ceiling suspension hardware (PDK-5002)	78
4.9.5 Mounting with PDK-5006 (wall -mounting hardware)	80
BEFORE BEGINNING ADJUSTMENTS	
5.1 Before Beginning Adjustments	83
5.1.1 Operating mode	83
5.1.2 Combination use of remote control unit, operating panel and PC	84
5.1.3 Lists of supported input signals	85
5.1.4 List of adjustable and settable items	88
5.1.5 Last memory	91
5.1.6 Aging	91

5.2 Normal Operating Mode	93
5.2.1 About normal operating mode	93
5.3 Menu Mode	94
5.3.1 About menu mode	94
5.3.2 Example of menu mode operation	95
5.3.3 Settings in menu mode	97
1) Setting power save	97
2) Setting the color system	98
3) Setting the three-dimensional Y/C separator	99
4) Setting HIGH CONTRAST	100
5) Setting up peripheral equipment	101
6) Setting the input signal format	102
7) Setting the clamp position	103
8) ABL ON/OFF	104
9) H / V enhancement tuning	105
5.3.4 Menu layers	106
5.4 Integrator Mode	108
5.4.1 About the integrator mode	108
5.4.2 Example of integrator mode operation	109
5.4.3 Adjustments and settings in the integrator mode	111
1) Adjusting the PICTURE	111
2) Adjusting the WHITE BALANCE	112
3) Adjusting the SCREEN	113
4) Adjusting the side mask	114
5) Setting the color mode	115
6) Setting the mirror mode	116
7) Setting the brightness enhancement at the screen center	117
8) Setting OSD display	118
9) Setting the baud rate	119
10) Setting FULL MASK	120
11) Setting the cooling fan control formula	121
12) Checking the inside temperature	122
13) Checking the accumulated ON time	122
14) Adjusting SUB VOLUME	123
15) Initializing Adjustments (ALL DEFAULT)	125
5.4.4 Menu layers	126
5.4.5 PICTURE and WHITE BALANCE adjustment values memory area tables	128
5.4.6 SCREEN adjustment values area tables	130
5.5 RS-232C Adjustment Mode	131
5.5.1 About the RS-232C adjustment mode	131
5.5.2 Interface	132
5.5.3 ID assignment	133
5.5.4 List of RC-232C commands	134
5.5.5 About the GET commands	136
5.6 Combination Connection	138
5.6.1 Connections	138
5.7 KEY LOCK/UNLOCK	140
5.7.1 Functions	140
5.7.2 How to switch KEY LOCK/UNLOCK	140
5.8 Regarding the problem of images becoming burnt onto the screen	141
OPERATING PRECAUTIONS AND RECOMMENDATIONS	142
6.1 Operating Precautions and recommendations	142
MAINTENANCE AND CLEANING	143

CAUTION

- To prevent injury and material damage, thoroughly read this manual and all labels found on the equipment before attempting to mount, install, move, or adjust the product.
- Do not install the unit outside or in the open air. Doing so will lead to water seepage into the system, resulting in fire or electric shock.
- Be especially careful when working around parts of the system that have sharp edges.
- When performing installation work from a height, take suitable precautions to guard against falling. Set up a barrier around the work site to prevent accidentally dropped objects from injuring persons standing or walking below.
- Keep all foreign objects out of the unit. Do not tamper with the unit, or fire or electric shock may result.
- Observe the following operating environmental limitations:
 - Temperature: 0 to 40°C
 - Humidity: 20 to 80%
- Install the unit only in properly ventilated areas.

Features

Features and Functions of the PDP-502MX Plasma Display

High definition, high contrast

- Through the newly-developed panel that aims for the optimum in luminous efficiency and development of a new drive sequence, we have achieved high contrast and a great improvement in brightness while maintaining high definition.

High quality, clear picture

- By digitalizing the signal processing circuit, we have made possible clear, precise image representation for all types of input signal (PC, video source etc.).
- Large screen with a built-in 8x-density IP converting circuit that results in high-quality video playback. Thanks to High Vision Progressive, the picture is clearer than ever before even with high vision TV signals.
- Designed especially to address the problem of the ghosting noise usually found in plasma displays, the PDP-502MX eliminates all ghosting.

Full XGA display; may also be used with compression as an SXGA/UXGA display

- Built-in 50-inch high-detail 1280x768 pixel (total 980,000 pixels) panel.
- 640 x 400 pixel display; able to display PC signals* at anywhere from full 640 x 480 (VGA) resolution to 1024 x 768 (XGA) resolution; may also be used at 1280 x 1024 (SXGA) resolution or 1600 x 1200 (UXGA) resolution. Full 1280x768 pixel display is also possible if the dedicated video card is used. Also compatible with HDTV signals**.

* SXGA resolution requires display image compression or partial display. UXGA requires display image compression.

** For playback of HDTV signals TV broadcasts, a separate DTV set top box is required.

Free choice of installation layout & slim design

- Highly efficient heat-dissipation design not only makes it possible to operate the display in a wider range of temperatures but also reduces the amount of ambient noise generated. Can be installed in a wide variety of ways and in a wide variety of locations .
- Light and compact design resulting in a large 50-inch display that is the thinnest and lightest of its kind in the industry. (Width: 98 mm; Weight: 40.3 kg.)

Packed full of features that make it ideal for business or public-address use

- Built-in integrator mode that allows more precise adjustment than ever before.
- Equipped with audio amplifier (2W + 2W).
- Equipped with ample I/O terminals (4 picture input systems, 2 picture output systems, 2 audio input systems, 1 audio output system, 1 speaker output system).
- Equipped with special power management system.
- Equipped with RS-232C terminal as an external control interface.
- Equipped with combination terminal that enables a number of display systems to be controlled together from a single PC.
- Equipped with operating mode monitoring system.
- Horizontal/vertical and left/right image rotation which makes it possible to use the display in a wide variety of different types of applications.
- Key-locking security provided to help prevent theft or unauthorized use.
- Color temperature (white balance) switching function is provided for retakes.
- OSD (On Screen Display) ON/OFF Function

- (NOTE 1) Do not make connections to the S terminal and a BNC terminal at the same time. This could cause malfunction or breakage of the device.
- (NOTE 2) The display is preset at the factory to 4800bps. This setting can be changed using either the remote control unit or a PC.
- (NOTE 3) Allow for 500 W ≠ 500VA of consumption per unit.
- (NOTE 4) The correct operating environmental temperature may vary, depending on the installation site. (Refer to Installation Site Requirements.)

INPUT Response Signals

INPUT 1: Composite video signal NTSC, PAL, SECAM, 4.43 NTSC

INPUT 2: Y/C Separate video signal NTSC, PAL, SECAM, 4.43 NTSC

INPUT 3, 4

Video signals supported

Vertical Frequency Fv (Hz)	Horizontal Frequency Fh (kHz)	Signal Format	Remark
50	15.625	Component RGB	
	31.25	Component RGB	
60	15.734	Component RGB	480i(SDTV)
	31.5	Component RGB	480p(SDTV)
	33.75	Component RGB	1080i(HDTV) HDTV signal
	45.0	Component RGB	720p(HDTV)
	67.5	Component RGB	1080p(HDTV)

PC signals supported

Caution : These signals are tested to work correctly. Other signal frequencies than listed may cause undesirable images.

Resolution (Dot x Line)	Vertical Frequency	Horizontal Frequency	Remark
640 x 400	56.4Hz	24.8kHz	NEC PC-9800
	70.1Hz	31.5kHz	NEC PC-9800
640 x 480	60Hz	31.5kHz	(852 x 480) (864 x 480)
	66.7Hz	35.0kHz	Apple Macintosh 13"
	72Hz	37.9kHz	
	75Hz	37.5kHz	
800 x 600	85Hz	43.3kHz	
	56Hz	35.2kHz	
	60Hz	37.9kHz	(1072 x 600)
	72Hz	48.1kHz	
832 x 624	75Hz	46.9kHz	
	85Hz	53.7kHz	
	74.6Hz	49.7kHz	Apple Macintosh 16"
	75Hz	49.7kHz	
1024 x 768	43Hz Interlace	35.5kHz	
	60Hz	48.4kHz	(1376 x 768)
	70Hz	56.5kHz	
	75Hz (74.9Hz)	60.0kHz (60.2kHz)	Figure in brackets are for Apple Macintosh 19"
	85Hz	68.7kHz	

Resolution (Dot x Line)	Vertical Frequency	Horizontal Frequency	Remark
1152 x 864	60Hz	53.7kHz	
	72Hz	64.9kHz	
	75Hz	67.7kHz	
1152 x 870	75.1Hz	68.7kHz	Apple Macintosh 21"
1152 x 900	66.0Hz	61.8kHz	Sun Microsystems LO
	76.0Hz	71.7kHz	Sun Microsystems HI
1280 x 768	56Hz	45.1kHz	
1280 x 960	60Hz	60.0kHz	
1280 x 1024	43Hz Interlace	46.4kHz	
	60Hz	64.0kHz	
	75Hz	80.0kHz	(1600 x 1024)
	85Hz	91.1kHz	
1600 x 1200	60Hz	75.0kHz	
	65Hz	81.3kHz	
	70Hz	87.5kHz	

External Dimensions

2.2 External Dimensions

Weight: 40.3 kg (without attachment stand)

Material: Front: Resin; Rear frame: Resin; Rear cover: Aluminum, Front protector panel: acrylic

Treatment: Front: Paint; Rear frame: Paint; Rear cover: Paint (All paints are Pioneer original colors)

For packaging information, refer to 3.3.2 "Unpacking".

● : Center of gravity

(Unit: mm)

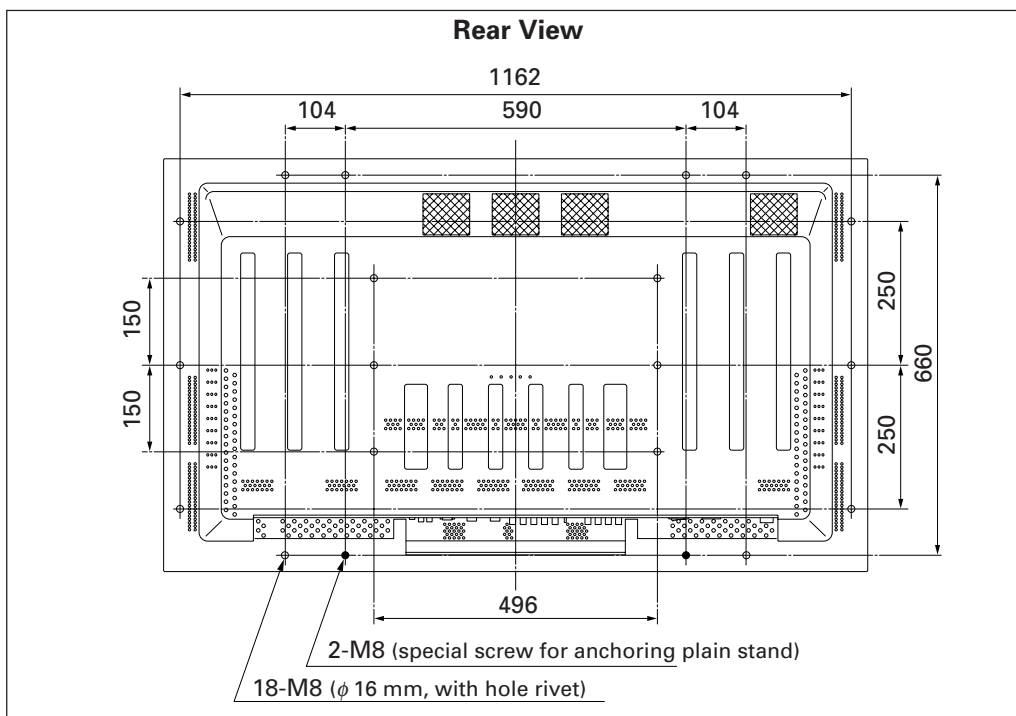
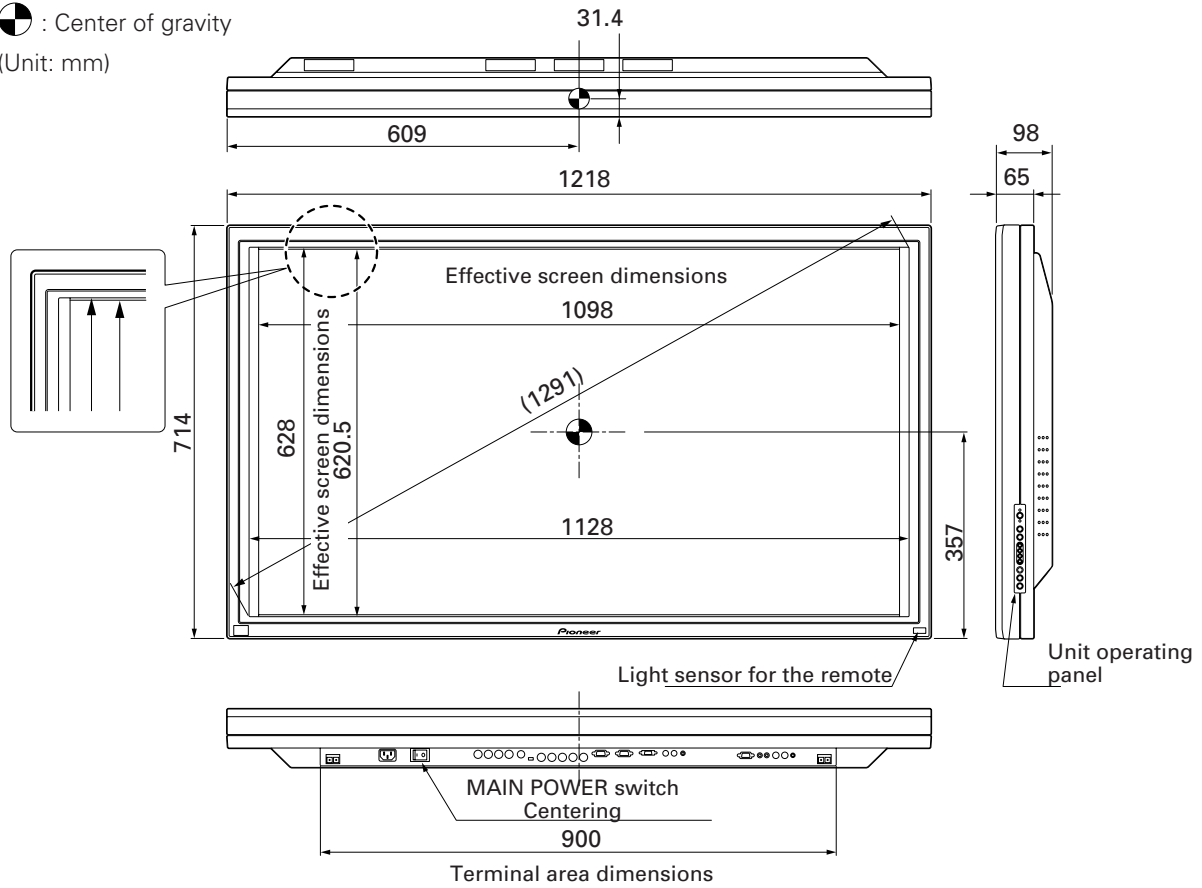

<Light Sensor for the Remote>

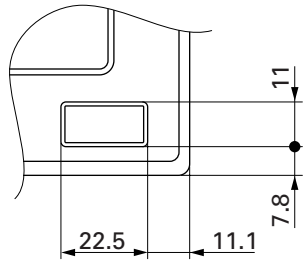

<Main Unit Operation Panel>

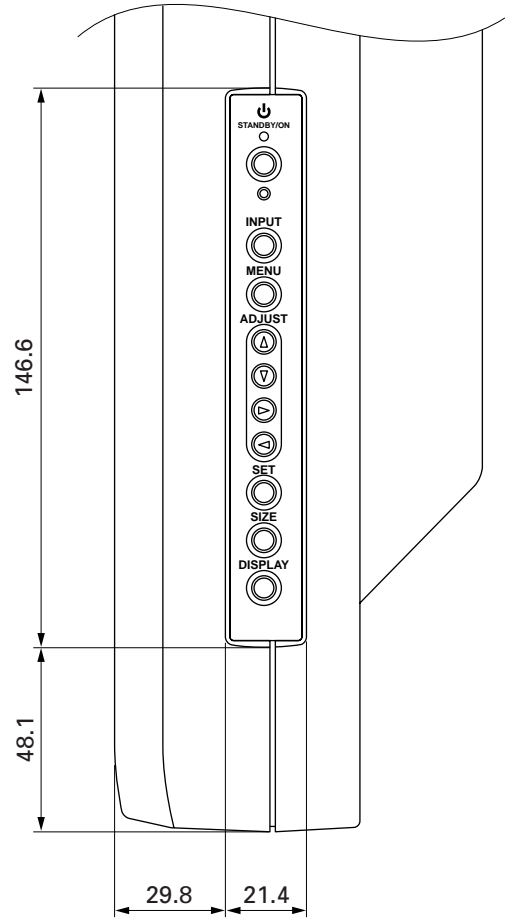

Controls and Connectors

2.3 Controls and Connectors

NOTE

When the optional plasma display speakers are attached, it is not possible to use the operation panel on the display.

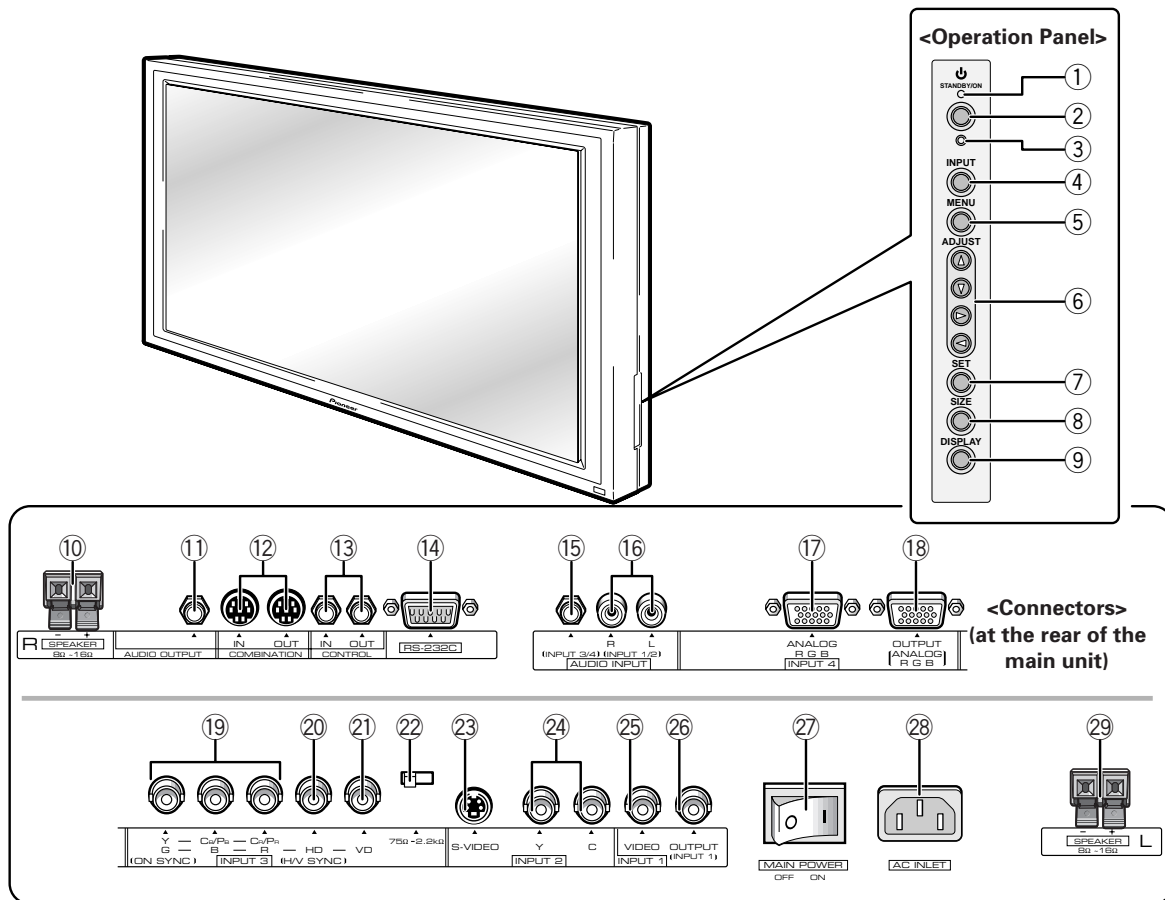

<Main Power Switch Section>

① STANDBY/ON indicator

Red when the display is in standby mode; turns green when the display is operational.

② STANDBY/ON button

Turns main power on or off.

③ KEY LOCK/UNLOCK switch (hidden)

Renders the operation panel and remote operative or inoperative.

④ INPUT button

Used to select inputs.

⑤ MENU button

Used to display the menu screen.

⑥ ADJUST (▲▼▶◀) buttons

Used to move the cursor on the menu screen or to increase/decrease adjustment values.

⑦ SET (select) button

Used to select an adjustment item on the menu screen or to change settings.

⑧ SIZE button

Used to manually change screen size.

⑨ DISPLAY button

Used to view input and settings conditions.

<Terminal Section>

⑩ SPEAKER

Output terminal for a right-hand external speaker. Connected to speakers of 8 to 16 Ω impedance.

⑪ AUDIO OUTPUT (Stereo mini jack)

Used to output the sound from a device connected to the display to a device such as an AV amplifier.

⑫ Combination Input and Output Terminals

Used for simultaneous control of various units.

(Refer to 5.6 "Combination Connection".)

Please use a Mini DIN 6-pin cable (straight, all pins wire bound; this is readily available on the market) as the connector cable.

(NOTE) No ABL linkage function is provided.

These terminals are incompatible with multi-projections such as the RM-V4000V.

When the main power is off, there is no output.

⑬ CONTROL IN/OUT terminals

For connection to Pioneer products that have the  mark. If you connect a CONTROL (If CONTROL connection is carried out) then you can carry out system control of the display.

(NOTE) This product does not support RU-V107 wired remote control units.

⑭ RS 232C terminal

Used to make adjustments from PC. (Conforms to EIA-232-F.)

(Refer to 5.5 RS-232C Adjustment Mode.)

⑮ AUDIO INPUT (Stereo mini jack)

Audio input for use when the picture input uses INPUT 3 or INPUT 4. Connect to the audio output terminal of the device that is connected to INPUT 3 or INPUT 4 of the display.

⑯ AUDIO INPUT

Audio input for use when the image input uses INPUT 1 or INPUT 2. Connect to the audio output terminal of the device that is connected to INPUT 1 or INPUT 2 of the display.

INPUT 4

⑰ INPUT 4 input terminal

Used to input an analog RGB signal or a component picture signal.

(NOTE) Also supports Green on Sync.

This terminal supports Microsoft Plug & Play (VESA DDC 1/2B).

⑱ INPUT 4 output terminal

Signals fed to the INPUT 4 input terminal (⑰) are output from this terminal. No signal is sent when power is switched off, or in standby status.

(NOTE) When connecting this unit, take a total of five other units as the standard number that can be set to receive input from it. However, when inputting/outputting to/from separate sync or composite sync, the source sync level at the end terminal must be 2.2 kΩ, and over 4.8 Vp-p.

INPUT 3

⑲ G(Y)/B(C_B/P_B)/R(C_R/P_R)

Receives signals from RGB or video hardware.

(NOTE) Also supports Green on Sync.

⑳ HD (H/V SYNC)

Receives signals of HD, and H/V Sync.

㉑ VD

Receives a VD signal.

㉒ Sync Signal Impedance switch

Used to switch impedance for items ⑳ and ㉑.

INPUT 2

㉓ S-VIDEO input terminal

㉔ Y/C Separate Video Input terminal

Receives signals from the Y/C separate video.

(Supports S2 output.)

(NOTE) Don't connect the S-jack and the BNC terminal at the same time. Doing so will result in system malfunctions or breakdown.

INPUT 1

㉕ Video Input terminal

Outputs signals received by the video input terminal.

㉖ Video Output terminal

Video input terminal (㉕) are output from this terminal.

Will not output when the power is off or in standby status.

(NOTE) When connecting this unit, take a total of five other units as the standard number that can be set to receive input from it.

㉗ Main Power switch

Turns the main power on or off.

㉘ AC INLET

Using the power cord accessory, connects to the AC power source.

㉙ SPEAKER

Output terminal for a left-hand external speaker.

Connected to speakers of 8 to 16Ω impedance.

Controls and Connectors

2.4 Pin layout

INPUT 4 (Mini D-sub, 15-pin connector; female) pin layout

Note : Standard VGA connector (plug and play supported).

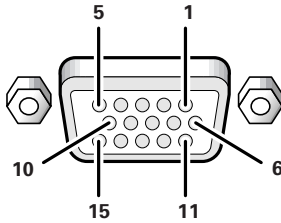

Pin No.	⑰ INPUT4 input terminals	⑱ INPUT4 output terminals
1	R or C _R /P _R	←
2	G or Y	←
3	B or C _B /P _B	←
4	NC (not connected)	←
5	GND	NC (not connected)
6	GND	←
7	GND	←
8	GND	←
9	DDC +5V	NC (not connected)
10	GND	←
11	NC (not connected)	←
12	DDC SDA	NC (not connected)
13	HD or H/V SYNC	←
14	VD	←
15	DDC SCL	NC (not connected)

RS-232C terminal (D-sub 9-pin connector; male) pin layout

Note : Plasma communicates as a DCE derice.

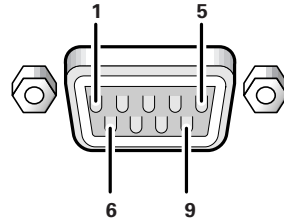

Pin No.	Signal
1	NC (not connected)
2	TxD (Transmit Data)
3	RxD (Receive Data)
4	NC (not connected)
5	GND
6	NC (not connected)
7	NC (not connected)
8	RTS (Request To Send)
9	NC (not connected)

Combination IN/OUT terminal pin layout

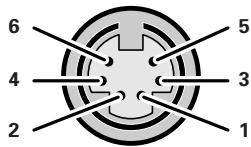

Pin No.	Combination IN	Combination OUT
1	GND	GND
2	Remote control (input)	Remote control (output)
3	TxD (output)	RxD (input)
4	NC (not connected)	NC (not connected)
5	RxD (input)	TxD (output)
6	NC (not connected)	NC (not connected)

2.5 Remote Control Unit

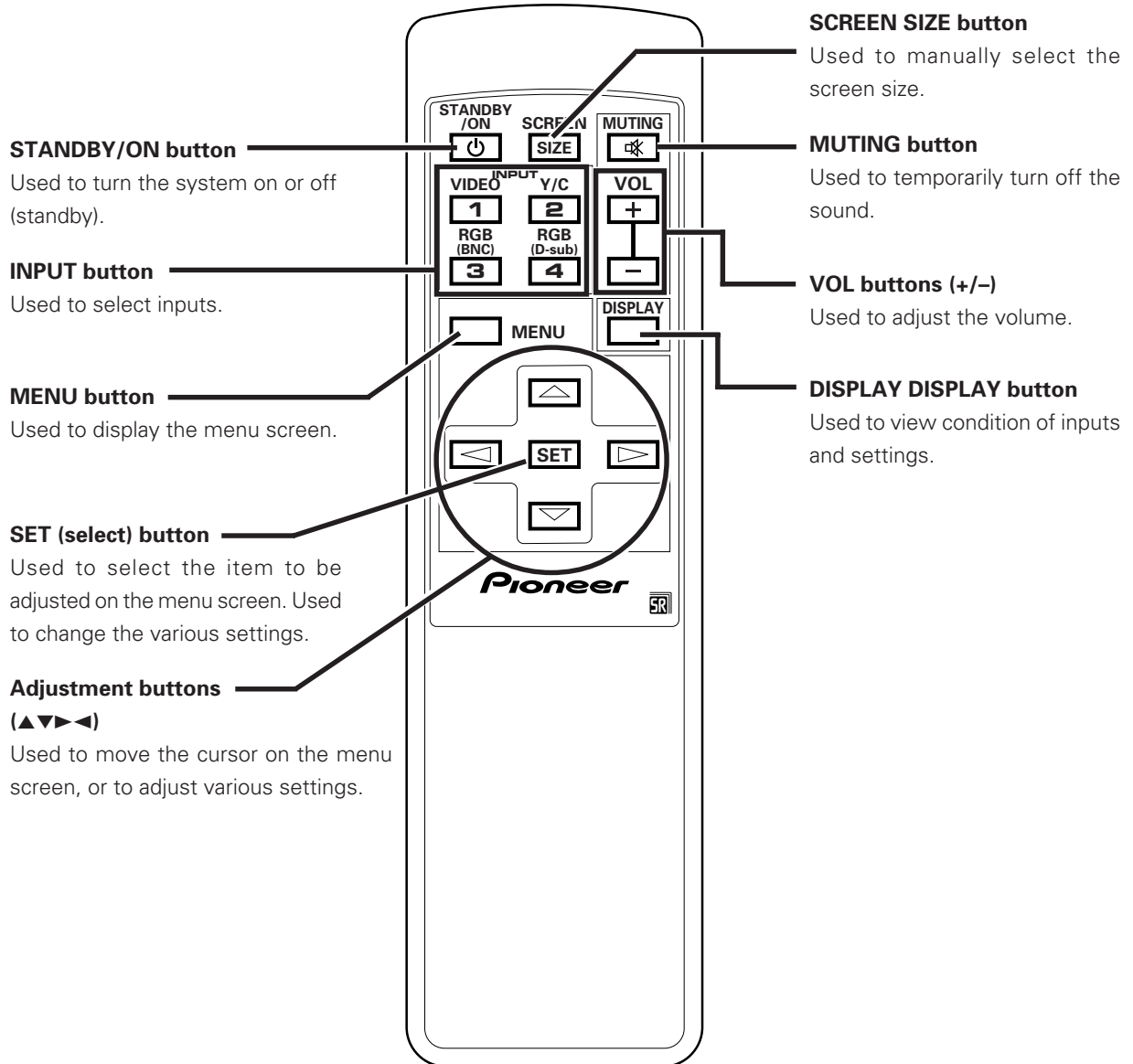

Remote Control Unit Case

2.6 Remote Control Unit Case

Peel the sticker paper off of the lower and upper tape on the rear side of the remote control unit case, and attach it to the rear of the main unit or some other fixed surface, so that it will be available for putting away the remote control unit when it is not in use.

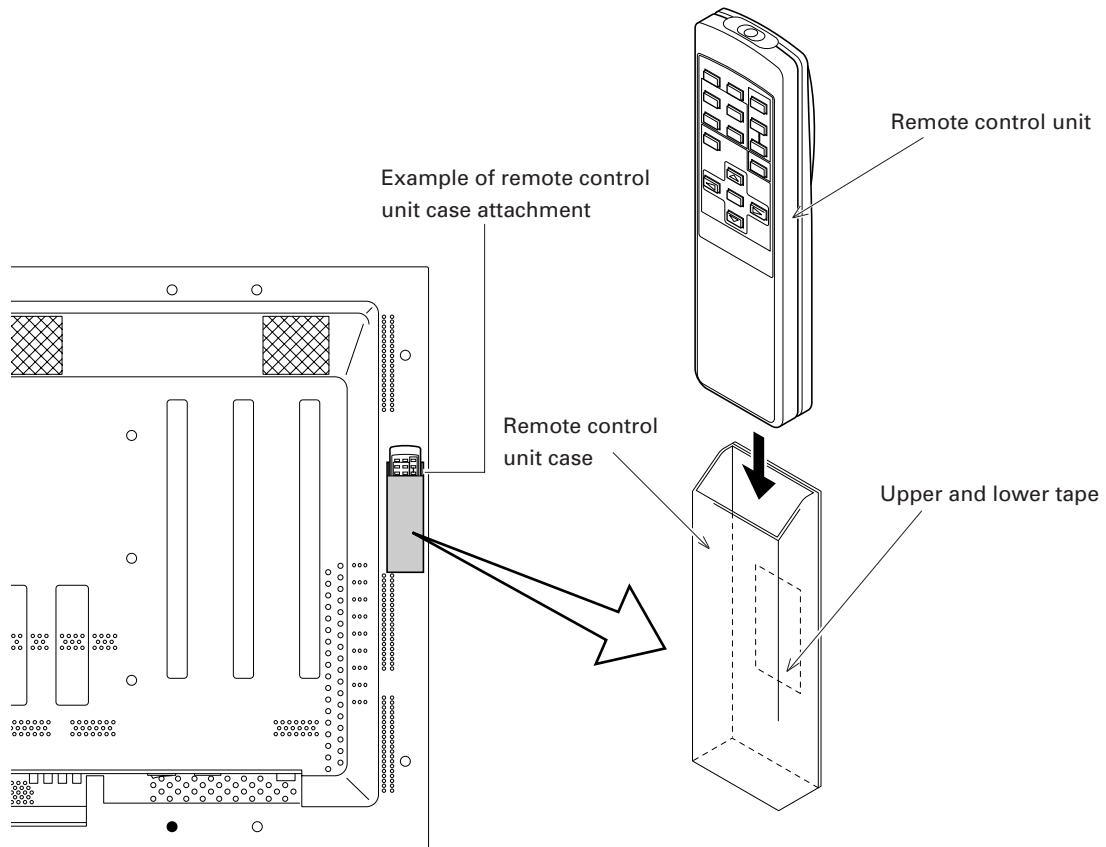

⚠ (NOTE) Do not obstruct the air holes in the remote control unit case.

Installation Site Requirements

3.1 Installation Site Requirements

If the site requires modifications or special preparations for installation of the plasma display or its mounting hardware, obtain permission in advance from the building owner or building authorities. To ensure installations safety, it is also important to determine the strength of the installation site with the help of the original building contractor.

Safety Precautions

1) Structure of the installation site

Make sure you thoroughly understand the structure of the installation site before determining the most suitable installation method. Buildings vary in structure and materials, and the appropriate mounting hardware with differ accordingly. When drilling into walls, always remain aware of the internal electric wiring and pipes.

2) Weight capacity of the installation site

Select a location with a weight capacity sufficient to support the total weight of the display and mounting hardware.

3) Flat, level surfaces

Select a flat, level surface for installation, such that mounting software will be parallel to the surface to which it is affixed.

Install the unit so that the load is evenly distributed along the ceiling or floor, as well as on mounting hardware such as hang bolts.

4) Sufficient work space

Select a location with sufficient space for installation work. The installation work should be conducted by two or more persons.

5) Nearby equipment

If air conditioning ducts or lamps, etc. are located near the installation site, the attendant dust, extreme temperatures, humidity, and condensation may become sources of trouble. Please take sufficient steps to avoid this.

6) Safe locations

Do not install the unit where it may be easily touched or leaned against. Avoid locations subject to high vibration or severe impacts.

7) Lighting conditions

- Consider existing lighting and sunlight angles when creating the installation layout. Extremely bright lighting can reduce the visibility and quality of the display image.
- In extremely bright surroundings, adjusting screen intensity may not result in perceptibly brighter images. Keep in mind that extreme intensity settings can reduce system service life.

8) Installation partially outdoors

The unit is designed for indoor use, and is not suited for open-air use. Installation in locations that are even partially exposed to the elements may lead to malfunctions or breakdown caused by any of the following:

- Water and dust
- Changes in temperature and humidity
- Salt-bearing wind

Direct sunlight upon the display degrades image quality. In installing the display, avoid sites exposed to direct sunlight.

9) Temperature and humidity conditions ⚠

- The installation site should meet the following conditions:
 - Operating temperatures: 0 to 40 °C (largely depending on installation conditions)
 - Operating humidity: 20 to 80 %
 - Storage temperature: -20 to 60 °C
 - Storage humidity: 20 to 90 %
 - Operating atmospheric pressure: 0.8 to 1.1 atm
 - Storage atmospheric pressure: 0.6 to 1.5 atm
- We recommend against installing electronic products such as this unit in locations subject to high humidity. If the unit is to be installed in a location subject to relatively high humidity, observe the following:
 - Failure to install the unit in unacceptable ways may result in non-warranty damages.
 - Make sure the unit is grounded.
 - Do not allow water or other liquids to enter the unit.

10) Prevent condensation

One of the chief sources of problems during the winter is “condensation”. Rapid temperature fluctuations can deposit water vapor inside the unit or on the screen, degrading performance. If condensation occurs, turn the unit off and leave it off for an hour or so. It is also good practice to increase the room temperature gradually. Beware of condensation. Consult Pioneer authorized dealers for assistance.

11) Power requirements ⚠

- This unit functions properly when powered at $\pm 10\%$ of its rated voltage. Characteristics of power lines may effect the voltage output. If any of the following occurs, contact an electrician to inspect the power.
 - Significant voltage drop between the circuit panel and the plasma display
 - Significant changes in voltage when switching the unit power on or off
- When calculating power consumption, allow for 500 W \neq 500 VA of consumption per unit.

(NOTE)

- **The in-rush current upon powering will be approximately 30 A.**

12) Effective remote control distance

This display emits weak infrared radiation. If other products controlled with infrared remote controls are placed nearby, remote control function may be affected. In such cases, move them further away from the display or contact Pioneer authorized dealer for assistance.

Depending on installation conditions, the range of the unit's own remote control may be reduced by infrared radiation emitted by the screen.

The screen's infrared intensity will vary, depending on the image displayed.

Installation Conditions

3.2 Installation Conditions

3.2.1 Heat dissipation

This unit has openings for effective ventilation at locations marked by arrows in the illustration below. **To allow proper dissipation of heat from the unit, avoid blocking or covering any of these openings.**

(Unit : mm)

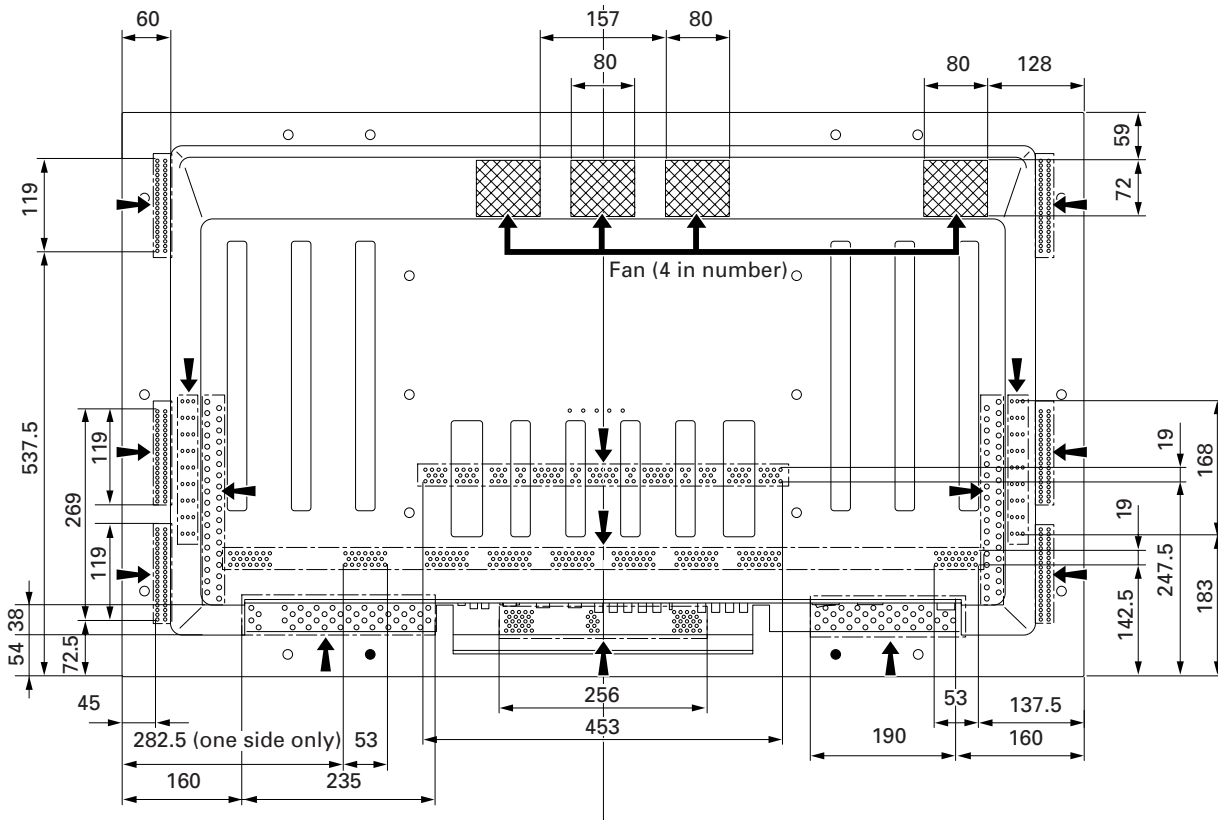

Air flow through the openings: All four fans draw off hot air from the unit. All openings not assisted by fans serve as air inlets. If the unit is hung from or embedded into a wall, special operating temperature limits and other limitations may apply. Refer to 3.4 "Special Installation".

3.2.2 Calculating heat quantity

As a courtesy to our customers, we have included the power formula to calculate the air conditioning needs.

For power consumption, allow for 500 W \neq 500 VA per unit.

Since most of the power consumed is transformed into heat, power consumption may be regarded as roughly equal to generated heat.

① Conversion to calories

$$[W] \times 0.86 = [\text{kcal/h}]$$

$$\text{Heat generated per display: } 500 \text{ W} \times 0.86 = 430 \text{ kcal/h}$$

② Conversion to British Thermal Units

$$[W] \times 3.41 = [\text{BTU/h}]$$

$$\text{Heat generated per unit: } 500 \text{ W} \times 3.41 = 1705 \text{ BTU/h}$$

3.2.3 Product mounting holes

We recommend using mounting hardware available from Pioneer. If you use other mounting hardware items, mount them to the unit using the M8-bolt holes provided in the unit. Remove the hole rivets, depending on the particular mounting hardware used. Tighten the bolts with a torque between 50 and 80 kg/cm. Applying a torque beyond these limits may lead to internal component failure.

- Locations of useable mount holes are shown below. (Caps or plugs can be removed by turning them with a coin or other device.)

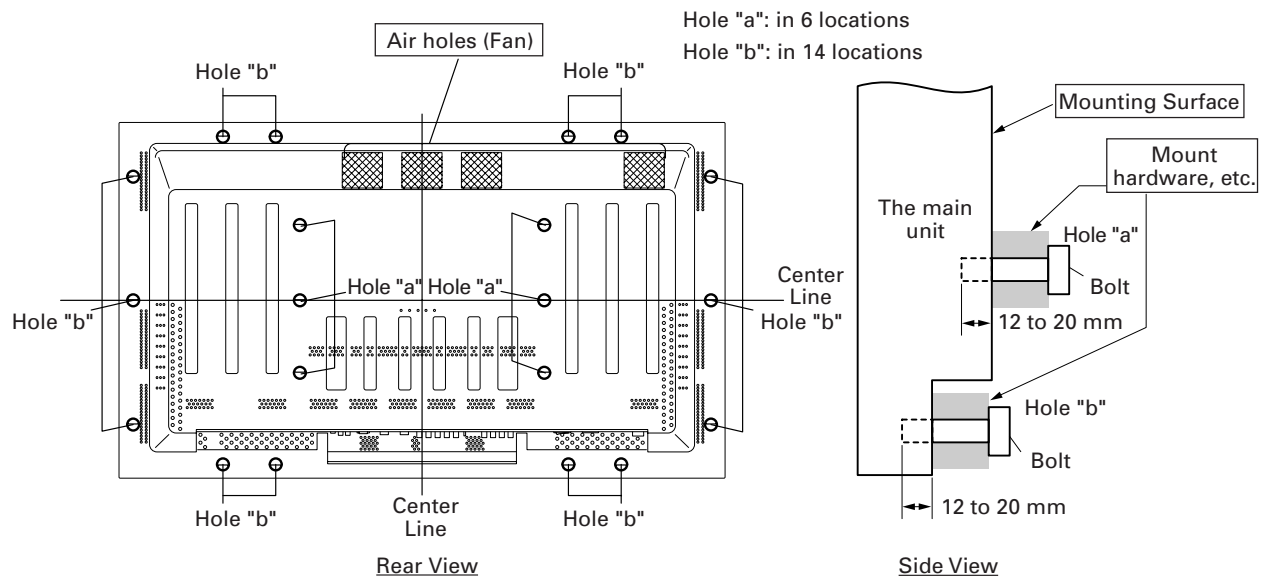

- ⚠ Always use a minimum of 4 mounting holes, evenly distributed on opposite sides of both the horizontal and vertical center lines.
- ⚠ Use bolts that can be driven 12 to 20 mm into holes "a" or "b", as shown in the Side View above.
- ⚠ Do not block or cover air outlets and openings for ventilation on the rear panel.
Take precautions to prevent soiling walls behind the product with exhaust air discharged from the air outlets.
- ⚠ This unit incorporates glass components. Install only on flat surfaces.
- ⚠ Always turn every bolt by hand 2 or 3 times and check to make sure it is straight, then tighten it using a tool.
Do not over tighten bolts.
Do not use loctight or similar bonding products.
- ⚠ Please make sure that you use M8 (P=1.25) bolts. (other types of bolt cannot be used).

Installation Conditions

This unit is designed to be mounted using four bolt holes. For additional safety, we recommend securing it at six to eight points on opposite sides of the horizontal and vertical center lines, as shown in the illustration below. Do not secure the unit at four points arranged in a single row, as shown below.

Methods for securing - Unfavorable examples

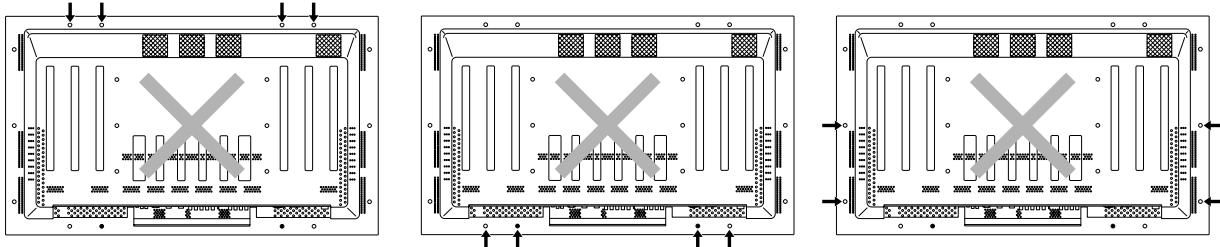

Methods for securing - Favorable examples

A. Secured at eight points

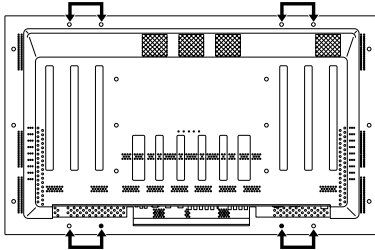

B. Secured at six points

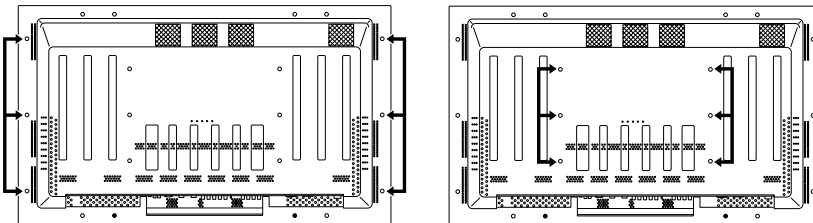

C. Secured at four points (with mounting hardware attached to the sides)

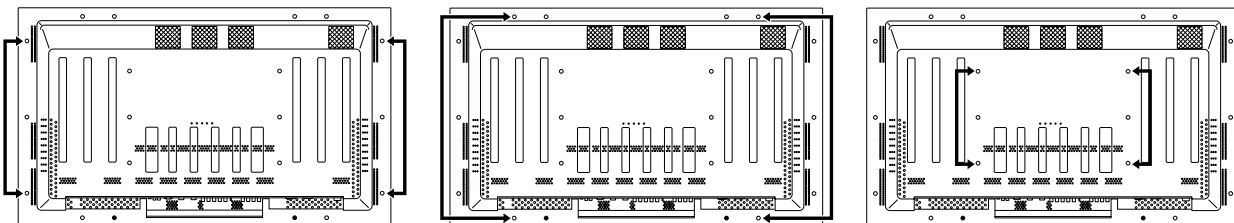

D. Secured at four points (with mounting hardware attached horizontally)

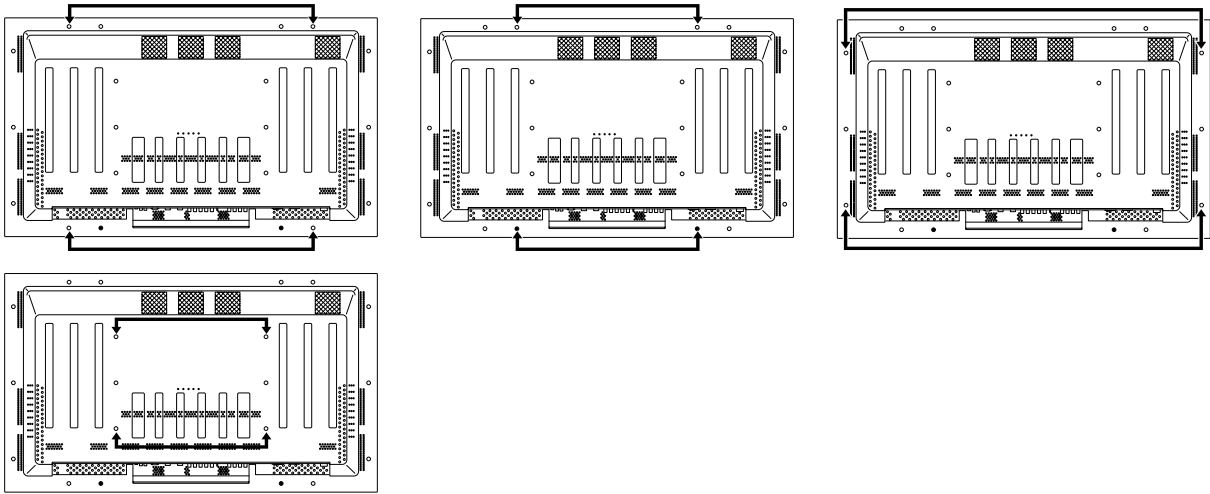

(Take proper precautions to prevent pinching the power cord or signal cables.)

3.2.4 Mounting surface warping

The display section incorporates glass. Before mounting the product, using hardware other than that provided by Pioneer, perform the following to confirm that the display is free from warps exceeding 1 mm*.

* Regarding the 1mm limit
 The frame of the display may have a warp of up to 3mm. If the total warp (the warp of the frame plus the warp of the mount surface) exceeds 4mm then the glass in the display may be put under excessive stress. In order to ensure that the total warp is less than 4mm, you should make sure that the warp of the mount surface is less than 1mm.

- ① Referring to the illustration below, diagonally extend string of maximum ϕ 0.1-mm diameter through the bolt mount openings. Strings thus arranged should be completely free of slack.
- ② Measure the clearance (L) between the strings at their point of intersection.
 Distortion is expressed by: $[Distortion] = L \times 2$.
- ③ If L is found to be 0, pass the strings through the other bolt mount openings and repeat the measurements. Any value of L greater than 0 indicates the presence of distortion. If the measured value in both cases is 0, the distortion is negligible.

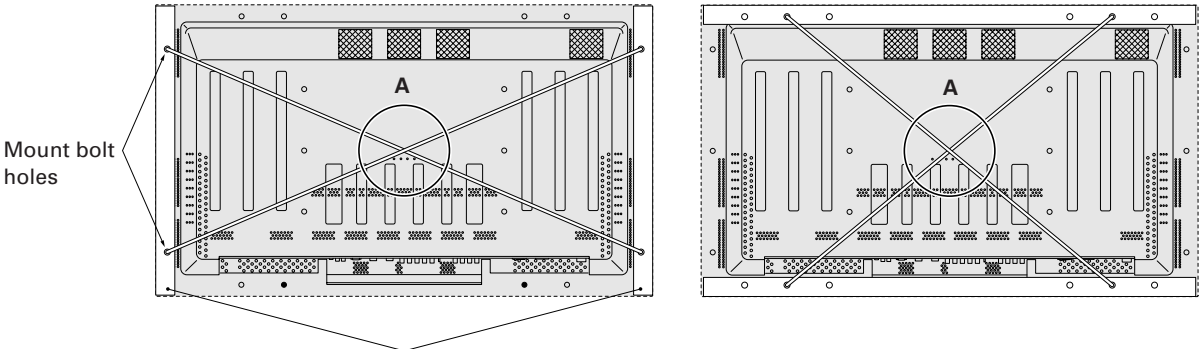

Plasma Display Mount Surface (Mount Brackets)

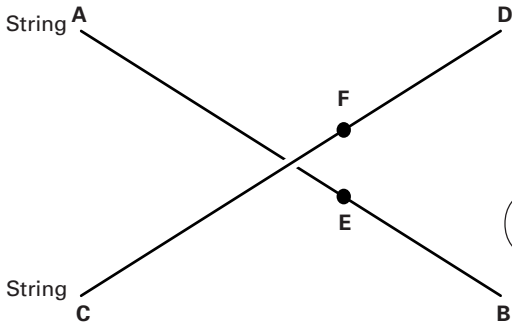

Point E is the center point of string segment A-B.
 Point F is the center point of string segment C-D.
 Clearance between points E and F = L.
 (Points E and F are shown displaced for illustrative purposes.)

Magnified view of section A

Installation Procedures

3.3 Installation Procedures

3.3.1 Transportation precautions

- ① Any transportation of the unopened unit in its packaging should be done by two or more persons. To avoid injury or damage, do not lift the package by its packing bands.
- ② When transporting or storing the unit, always position it vertically - never horizontally. Horizontal transportation or storage invalidates the product warranty
- ③ In transportation or storage of products in original packing, never stack more than three units high. This warning is also indicated on the upper face of the carton.
- ④ For transportation or storage, observe the warnings and instructions on the upper face of the carton.
- ⑤ Plasma display is mode off grass. Please take precautions to prevent it from being damaged.

3.3.2 Unpacking

The original packing material can be re-used to safely ship the Plasma Display. When doing so, it is important to use the material in the same way as when they were originally shipped. Failure to correctly use the material can damage the display.

- 1) Packing specifications: 1341 (W) × 890 (H) × 424 (D), 53 kg

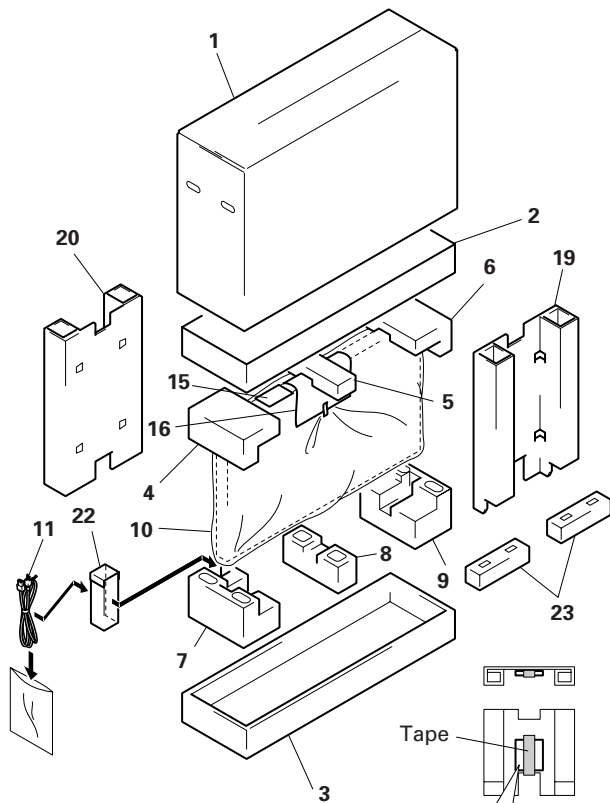

Ref. No.	Terms
1	Upper face of the carton
2	Carton cover
3	Lower face of the carton
4	Upper pad L
5	Upper pad C
6	Upper pad R
7	Under pad L
8	Under pad C
9	Under pad R
10	Miller mat
11	Power cord
12	Remote control unit (CU-V159)
13	2 manganese AA batteries, R6P
14	Operating instructions
15	Guarantee
16	Warranty card
17	Binder Assembly
18	Wiping cloth
19	Front face of the carton
20	Rear face of the carton
21	Pin/BNC conversion connector
22	Power cord case
23	Display stand case (with display stand inside)
24	Remote control unit case
25	Bolt, Washer

These accessories shall be packed in a bag, which then shall be stuck to 19 (front carton) with a piece of adhesive tape.

2) Unpacking procedures

- ① Remove the packing bands.
- ② Slowly lift and remove the upper carton.
- ③ Lift and remove the carton cover.
- ④ Remove the L, C and R upper cartons.
- ⑤ Remove the front and rear cartons.
- ⑥ Remove the operating instructions and accessories, which are secured to the lower carton by adhesive tape.
- ⑦ Remove the unit. (This should be performed by two persons.)

3) Transportation of the unpacked unit.

If it needs to be moved, the unit should be lifted by two persons.

- Never move the unit by dragging it along the floor.
- Move the unit slowly, taking care to prevent scraping or striking the delicate front protective panel.
- In order to prevent adhesion of dust, remove the protective film only after all work and preparations for the installation site, including clean-up following unpacking, are complete.

3.3.3 Mounting on the attachment stands (See 4.3 "Installation of the Attachment Stand" for instructions on permanent installation.)

Insert the stand bolt into holes (A) and (A') so that the head of the bolt can slide into the slot in the stand.

Unpacking procedure stops at Step 2), ⑥, above. Bolts (A) and (A') can be made to slide into the slot in the stand before the unit is unpacked. This method should, insofar as possible, be a temporary setup pending proper installation. When installing the attachment stand, consult 4.3 "Installation of the Attachment Stand". If making the attachment to position (B), use the (B) hole rivet, or remove the (A) stand bolt and attach it to position (B).

 Placing the screen on the stands is only a temporary step before proper installation. We cannot guarantee against damage to the screen caused by it toppling over under an external force etc. while it is placed on the stands.

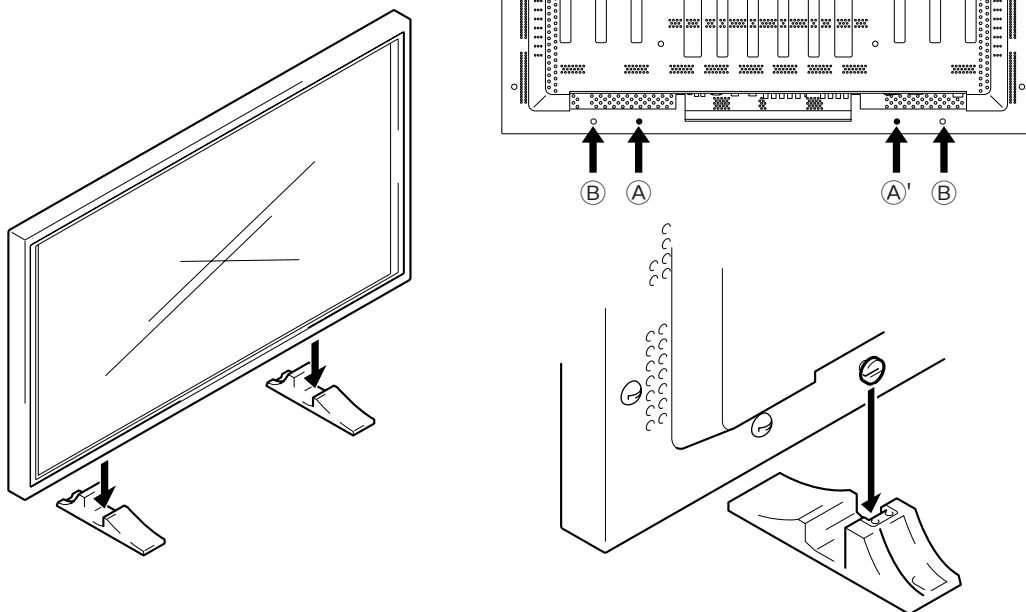

3.3.4 Re-packing (re-packing and re-shipping are not covered by the warranty.)

If the unit needs to be re-packaged, observe the following guidelines.

- Pack by performing in reverse order the steps described in 3.3.2 "Unpacking". The miller mat must be positioned so that the shiny film surface faces outward and its soft surface faces inward (toward the unit).
- Restore all accessories to their original locations. Secure with adhesive tape to prevent damage during transportation.
- Do not re-package and ship if the packing material is damaged.

Installation Procedures

3.3.5 Wiring

1) Connecting the power cable

- Refer to the section on **Power Cord Connection** on p. 16 of the operating instructions.
- For power source specifications, refer to 3.1 "Installation Site Requirements", Section 11) Power requirements, above.

2) Connecting signal cables

(1) Please refer to p10~17 of the instruction manual for instructions on how to connect a PC or a video device.

(2) Important notes

- Use coaxial cables. As a rough guide, for video signals use 3C-2V cables for lengths up to 15 meters, and 5C-2V cables for lengths up to 30 meters. Use thicker cables for computer signals, since these signals are more likely to degrade: 5C-2V cables, for example, for 15-meter lengths. Generally, thicker cables will produce more reliable connections. You can also improve signal quality by minimizing cable length.
- Video cables plugged into video inputs and outputs close to dimmers, neon signs, air-conditioning units, or cables for wired broadcasts may occasionally deliver slightly corrupted images.

3) Processing wires

- In the case of permanent or long-term installation, please be careful to select cables of the correct length, considering the whole wiring route when doing this (this is not so important in the case of short-term installation such as with special events).
- Arrange and secure cables so that they will not be subject to direct load or physical force. For temporary installation, securing cables with string should be perfectly adequate. For permanent installations, secure by more reliable means.

4) Arranging and securing cables with speed clamps and bead bands

1 Fasten cables using the supplied speed clamps.

! Remember that speed clamps are not easily removed, once fastened.

2 Secure cables with the supplied bead bands.

* Display viewed from the rear.

Cables may be drawn around to the right, viewed from this side.

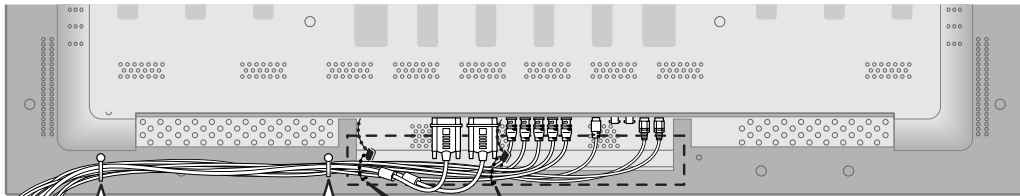
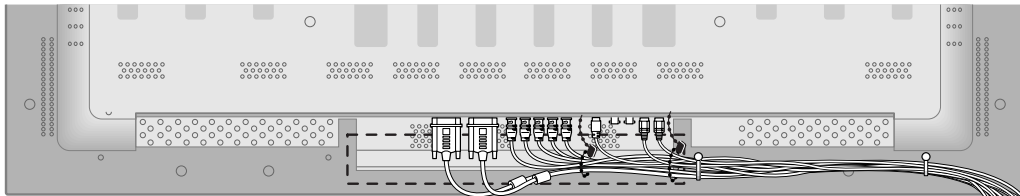

1 Secure cables with speed clamps.

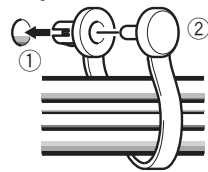

Insert part ② into an opening in the rear cover, then insert part ①, as shown.

2 Bundle cables using bead bands.

Use the head band at two positions within the indicated range [] .

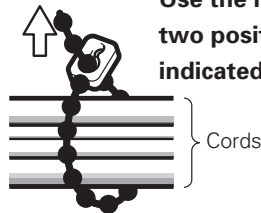

Fastening points for speed clamps

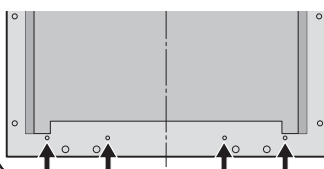

Bundled cables can be drawn to the left or the right. Depending on specific requirements, you may use the four opening indicated by solid circles ●.

How to unlock the speed clamp

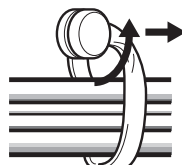

Use a pair of pliers to twist the clamp by at least a quarter-turn and pull outward. Remember that this procedure entails risk of damaging the clamp.

Special Installation (Mounting to fittings)

3.4 Special Installation

The unit can be hung from or embedded in a wall, but such special installations impose additional limitations on operating temperatures and other operational factors.

Examine installation methods and the ambient conditions for your installation site, and refer to sections 3.1 to 3.3 in this manual.

Measurements discussed in this manual assume the following conditions:

- A 100 % white input is supplied.
- Sufficient aging has been completed.

Make all measurements under identical conditions. The aging period required for correct measurement will be about two and a half hours, depending on the space available at the installation site.

3.4.1 Mounting to fittings

Observe the following guidelines when mounting the unit to fittings.

Notes ② to ⑦ apply to all cases of mounting to fitting.

- ① When mounting the unit, make sure that there are no objects around it within a distance of 300mm.
- ② Any unit deformation/warping occurring as a result of installation should be less than 4 mm.
- ③ Never block or cover openings, aside from those shown as blocked in the illustrations on the following page.
- ④ The fittings should have a thickness of less than 20 mm. (This limit does not apply to fittings in examples 2, 4, 6 and 8 on the following page.)
- ⑤ L-shaped fittings should have a thickness of less than 100 mm.
- ⑥ The strength of the fittings should be adequate to bear the weight of the display.
- ⑦ Take precautions to avoid sharply bending the power cable.

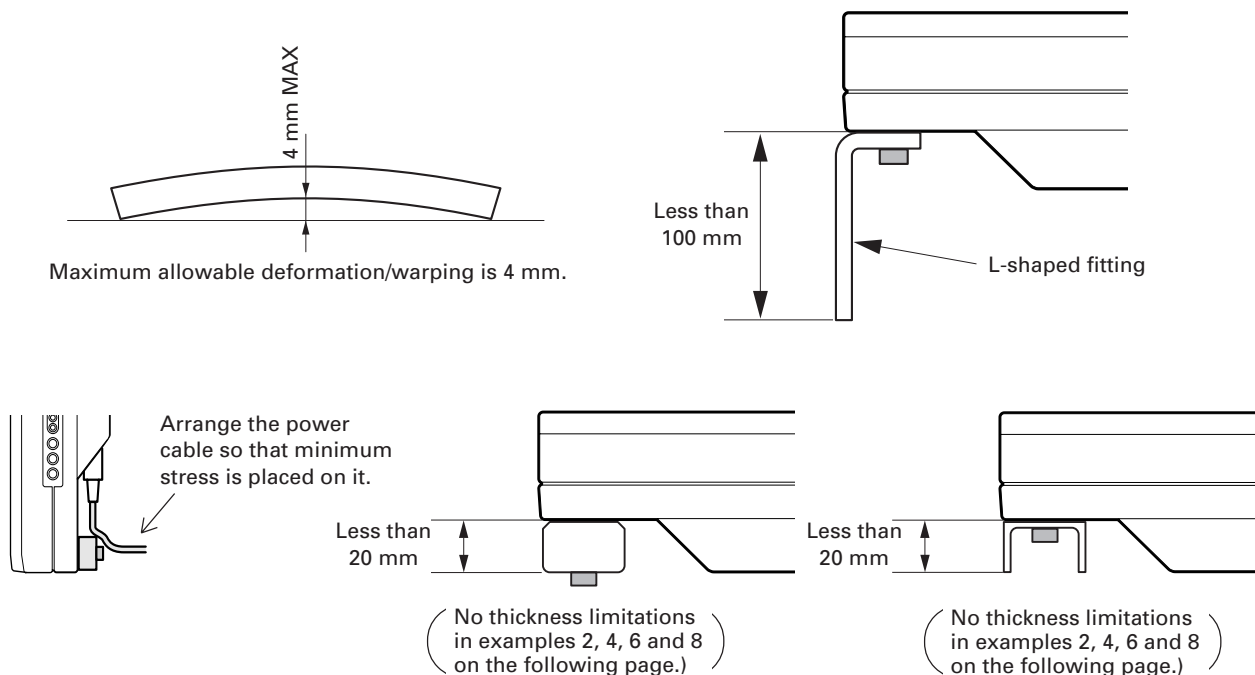

☆ Operating environment for standard installation

- Ambient Temperature: 0 to 40 °C (examples 1 to 4)

☆ Operating environment for vertical installation

0 to 40 °C (vertical installation: examples 5 to 8)

☆ Operating temperatures for Upside-Down Installations (possible only for attachment examples 2 and 3)

- Ambient temperature: 0 to 40 °C

The operating temperature restrictions for the speaker system (PDP-S03-LR) are the same regardless of whether installation is horizontal or vertical.

Special Installation (Mounting to fittings)

Standard installation (Note that only Examples 2 and 3 apply in cases where top and bottom are reversed)

Example 1

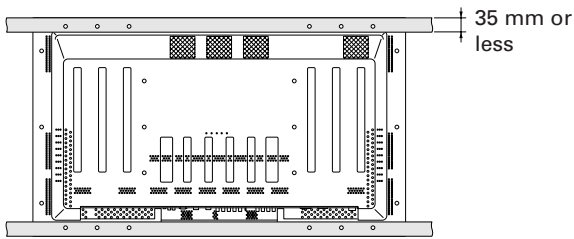

Example 2

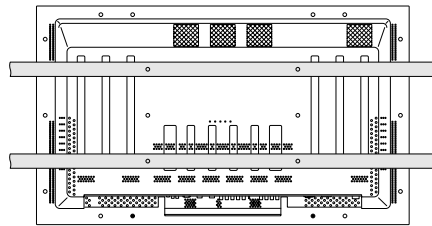

Example 3

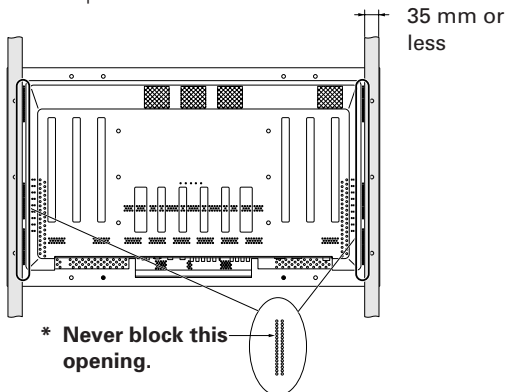

Example 4

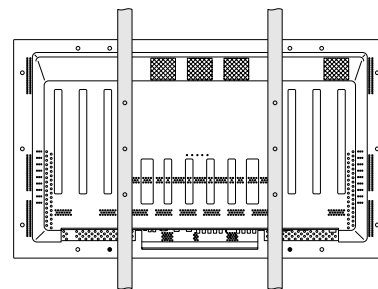

Vertical installation

Example 5

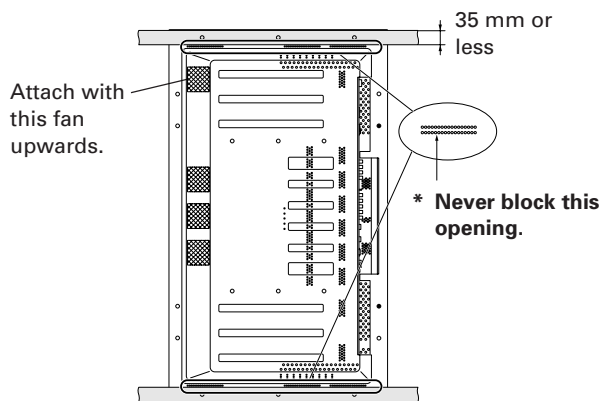

Example 6

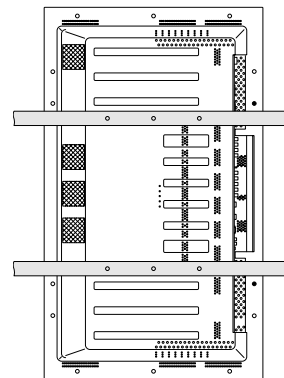

Example 7

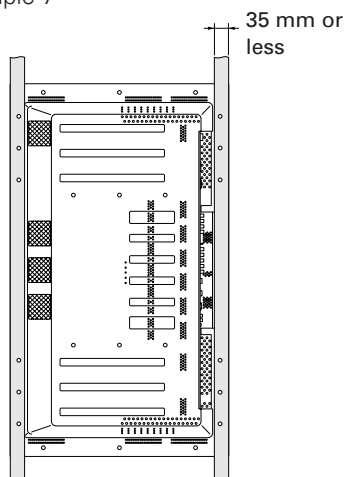

Example 8

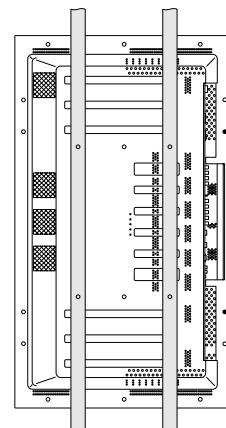

Special Instruction (Hanging on the wall)

3.4.2 Hanging on the wall

Carefully read the following before attempting to hang the unit on a wall, and observe the various limitations specified below. Be sure to mount the unit so that twisting, bending, or any other deformation does not exceed 4 mm.

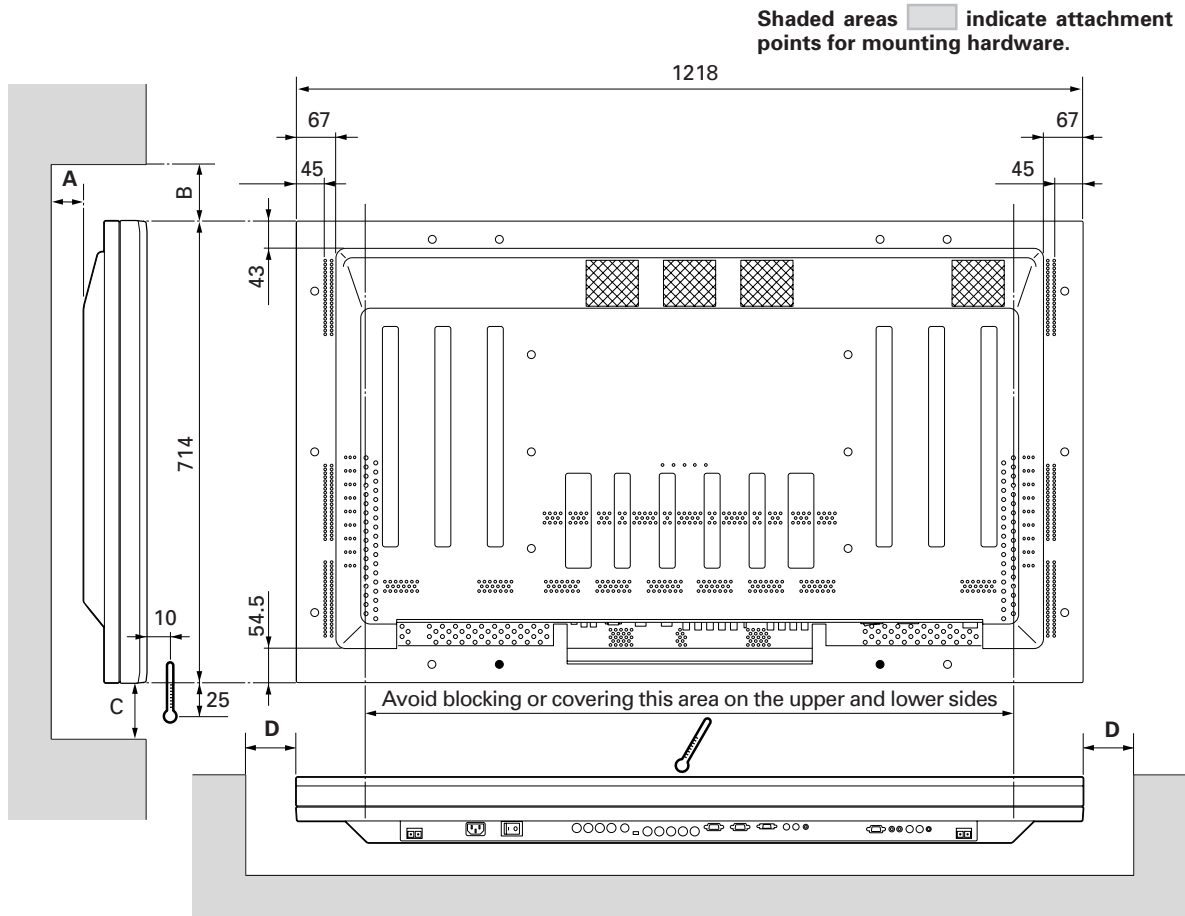

Operating temperature restrictions

☆ Standard single-unit installation

- * When attached using PDK-5005 PDP brackets, the distance A between the unit and the wall must be no less than 50 mm.

Distance from wall (A)	B	C	D	Ambient temperature
50 mm or less	300 mm or more	300 mm or more	300 mm or more	0 to 35°C
50 mm or more	100 mm or more	50 mm or more	50 mm or more	0 to 40 °C

☆ Horizontal/vertical, left/right reverse installation (Note that only Examples 2 and 3 apply in cases where top and bottom are reversed)

- * No matter what the distance between the unit and the wall, the unit must be installed in such a way as to ensure free air flow (With no obstructions within a distance of 300 mm from the unit).

Distance from wall (A)	B	C	D	Ambient temperature
None	300 mm or more	300 mm or more	300 mm or more	0 to 35°C

☆ Requirements when used with PDP-S03-LR speaker system

When installed as a single unit, all requirements are the same as those listed above for horizontal/vertical, left/right reverse installation. Note, however, that the figures listed above are to be interpreted as indicating the distance between the speakers and the wall.

(NOTE) Different temperature restrictions apply to the PDK-5006. Refer to 4.7 "Tiltable Plasma Display Wall-Mount Hardware". In wall-mounting installation, allow adequate space (a clearance of 300 mm or more) above and below the monitor set, as well as to the right and left.

Special Installation (Hanging on the wall)

Methods of Securing: Basic methods of securing are shown below. Avoid blocking or covering areas aside from those indicated by . The method indicated by a large X-mark must not be used. Before attaching the unit to fittings, double-check that the thickness and height of the fittings, and the number of fixing bolts is correct. (Also refer to 3.4.1 "Mounting to fittings".)

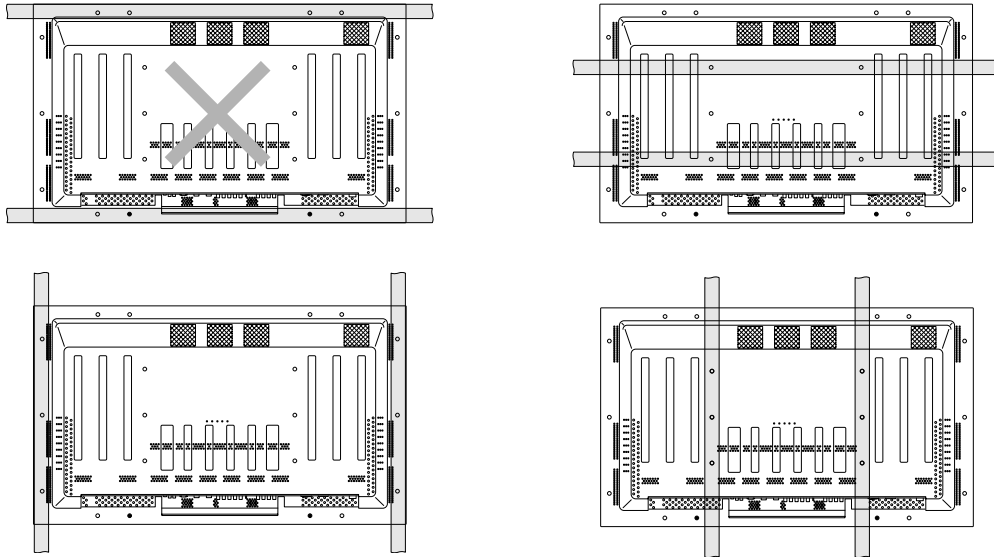

NOTE 1

Heated air is drawn off from the interior of the unit by fans. Before installation, consider the heat resistance of the wall or other surfaces behind the unit. Exhaust temperatures can be 30 °C higher than the outside temperature.

NOTE 2

For wall-mounting, do not bundle the cables in a way that will obstruct ventilation.

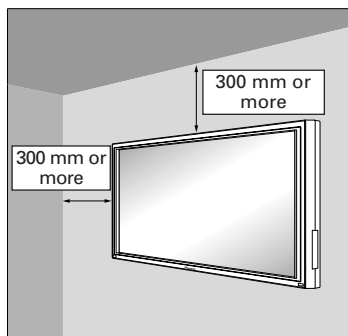

Flush-wall installation (distance between unit and wall less than 50 mm)

Requirements :

- Free air flow (With no obstructions within a distance of 300 mm from the unit)
- Temperature of 0–35°C

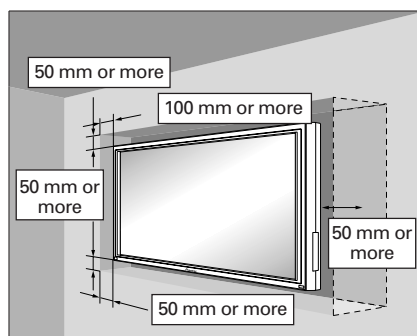

Ex.: Installation requirements when installed in recess in wall

Wall-mounted installation (distance between unit and wall greater than 50 mm)

Requirements :

- Free air flow (With no obstructions within a distance of 300 mm from the unit) around all four sides of the unit is not necessarily required when the unit is installed at a distance of greater than 50 millimeters away from the wall.
- * Note, however, that in such cases the unit may not be placed behind a glass panel or any other obstruction which would create a closed space.
- Temperature of 0–40°C

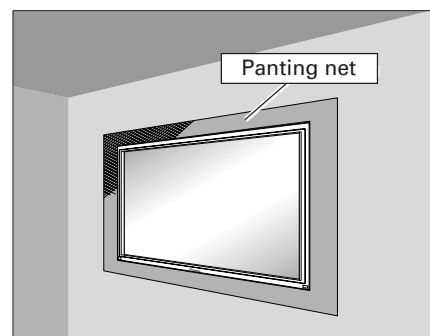

Ex.: Installation when covered with a Panting net

Wall-embedded installation (i.e., installation in closed space)

Requirements :

- See 3.4.3 Embedding in the wall for installation requirements..
- Temperature of 0–40°C

Special Installation (Embedding in the wall)

3.4.3 Embedding in the wall

Carefully read the following before trying to embed the unit in a wall, and make sure to observe all the limitations specified below.

Be sure to mount the unit so that twisting, bending, or other deformation of the unit does not exceed 4 mm.

- (1) Embedding in walls with space provided behind the unit (With no obstructions within a distance of 300 mm from the back surface of the unit).

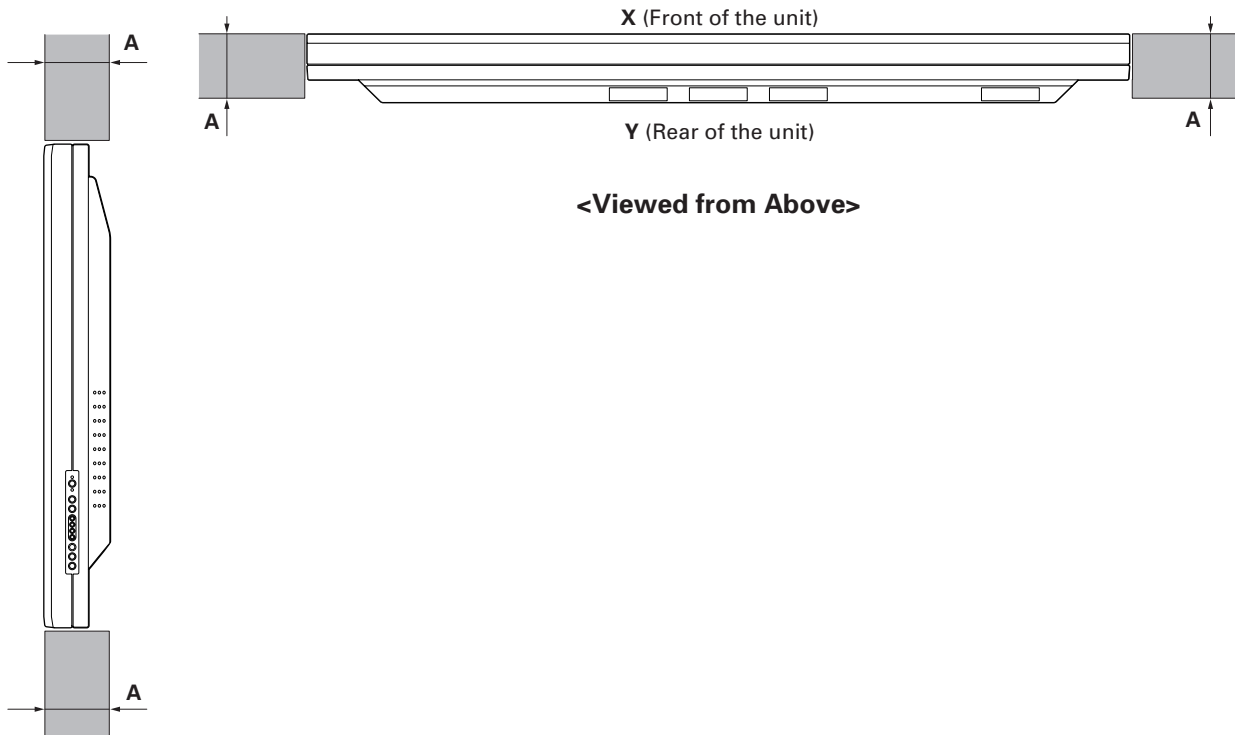

<Viewed from the Right Side>

☆ Operating Temperature Restrictions

	Temperature in space X and Y
A: 0 to 370 mm	0 to 40 °C

* The same operating temperature restrictions apply to the speaker system (PDP-S03-LR).

☆ Operating Temperature Restrictions for Upside-Down Installations

* Upside-down mounting is unavailable when embedding this device in a wall.

Special Installation (Embedding in the wall)

Methods of Securing: Basic methods of securing are shown below. Avoid blocking or covering areas aside from those indicated by . The methods indicated by a large X-mark must not be used. Before attaching the unit to fittings, double-check that the thickness and height of the fittings, and the number of fixing bolts is correct. (Also refer to 3.4.1 "Mounting to fittings".)

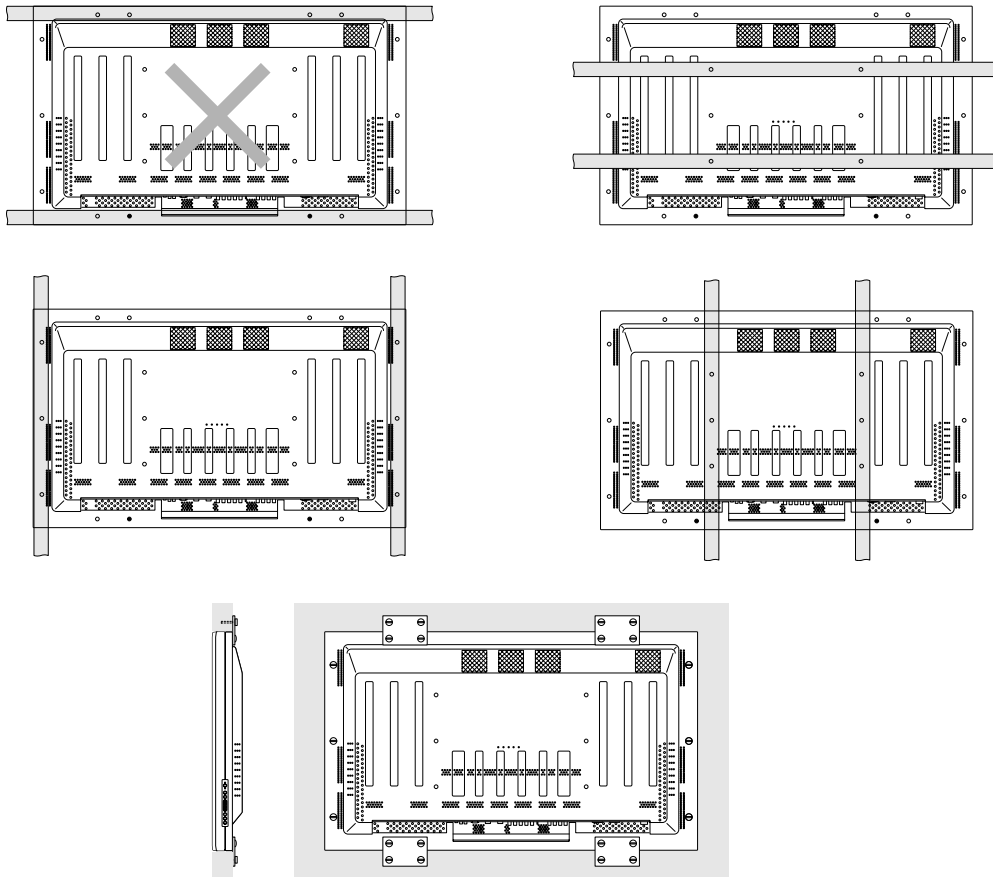

Temperature Measurement Points (Illustration for reference purposes)

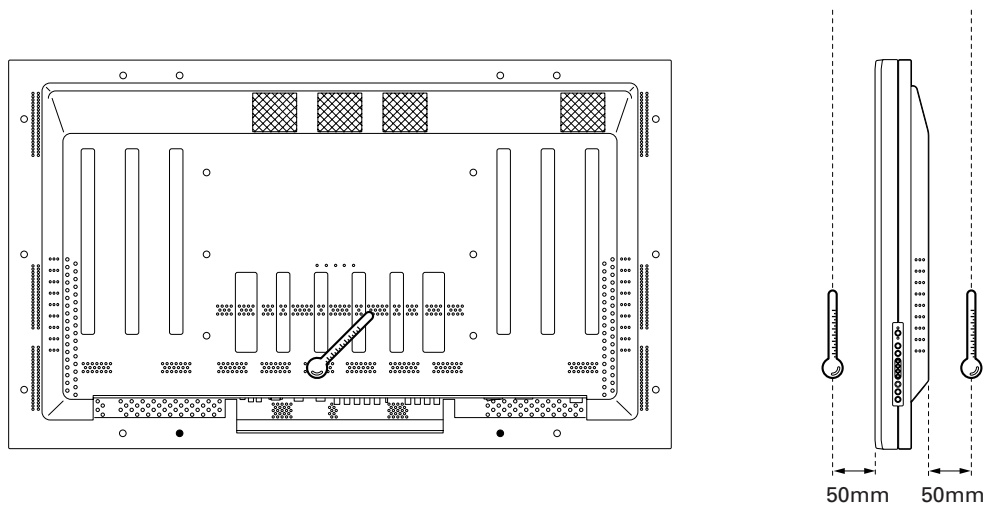

- Make measurements at a distance of 5 cm from the unit, without directly subjecting the thermometer to fan exhaust.
- For spaces where temperature fluctuations are likely, gather additional measurement points for an adequate data set.

Special Installation (Embedding in the wall)

(2) Embedding in walls with no space provided behind the unit.

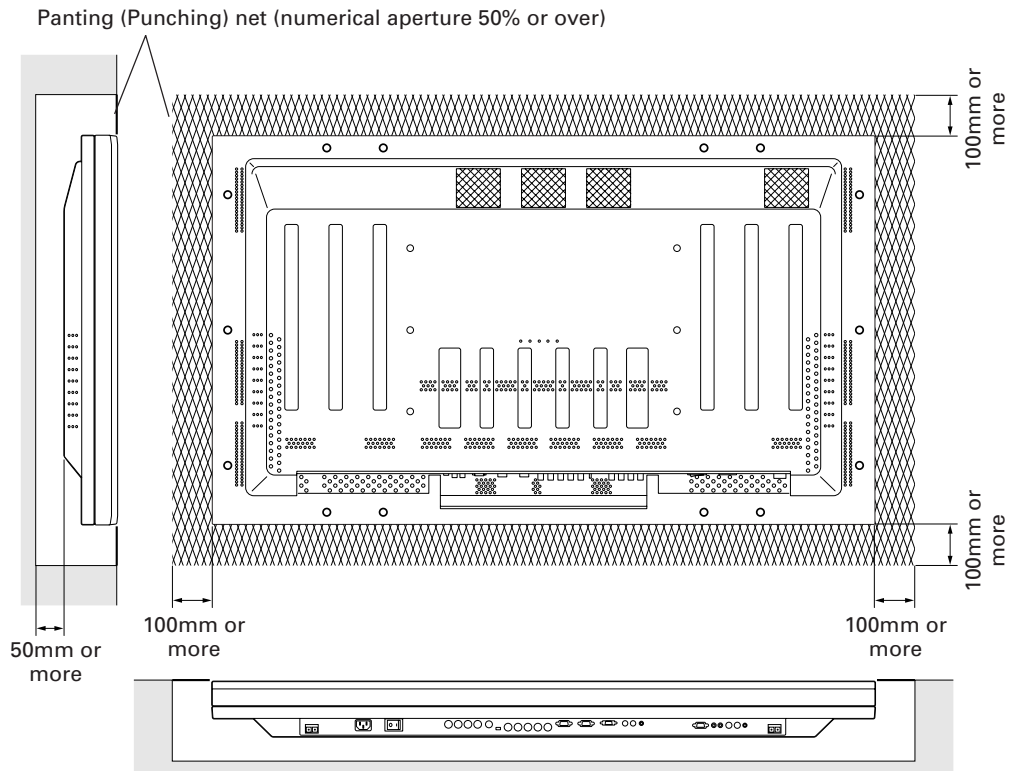

Cation : Due to possible heat up, we do not recommend installation in narrow, enclosed areas.

☆ Operating Temperature Restrictions

- Ambient temperature: 0 to 40 °C
- The same operating temperature restrictions apply to the speaker system (PDP-S03-LR).

☆ Operating Temperature Restrictions for Upside-Down Installations

- * Upside-down mounting is unavailable when embedding this device in a wall.

Special Installation (Embedding in the wall)

Methods of Securing: Basic methods of securing are shown below. Avoid blocking or covering areas aside from those indicated by . The methods indicated by a large X-mark must not be used.

Before attaching the unit to fittings, double-check that the thickness and height of the fittings, and the number of fixing bolts is correct.

(Also refer to 3.4.1 "Mounting to fittings".)

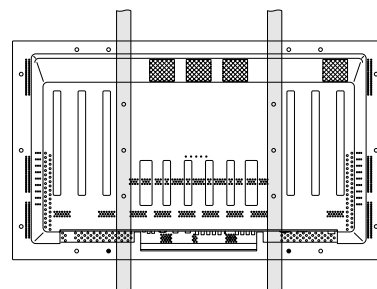
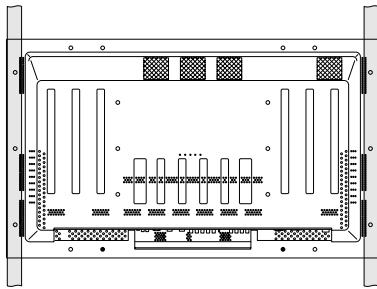
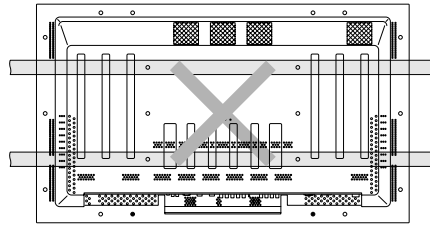
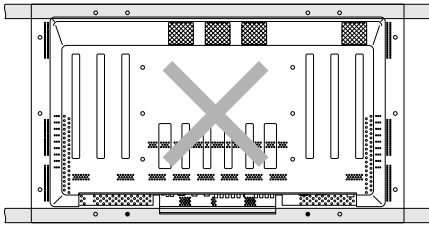

Special installation (When the display is put in a box)

3.4.4 When the display is put in a box

Operating this display in confined spaces is not recommended.

- If the display is to be used in confined spaces, observe the following conditions shown in the drawing in a page to the right:

$$A \geq 50$$

$$B \geq 50$$

$$C \geq 10$$

$$D \geq 50$$

Use a mesh with aperture efficiency of 50% or more.

Thus, everywhere in "Y" must be kept less than the following temperature range. If hot air remains in the closed space, the temperature may rise, causing a malfunction or fire. As a precaution in case of accidents, the inner wall should have sufficient heat resistance or fire resistance.

☆ Usage temperature conditions (BOX air temperature)

- Ambient temperature: 0 to 35 °C

Special installation (When the display is put in a box)

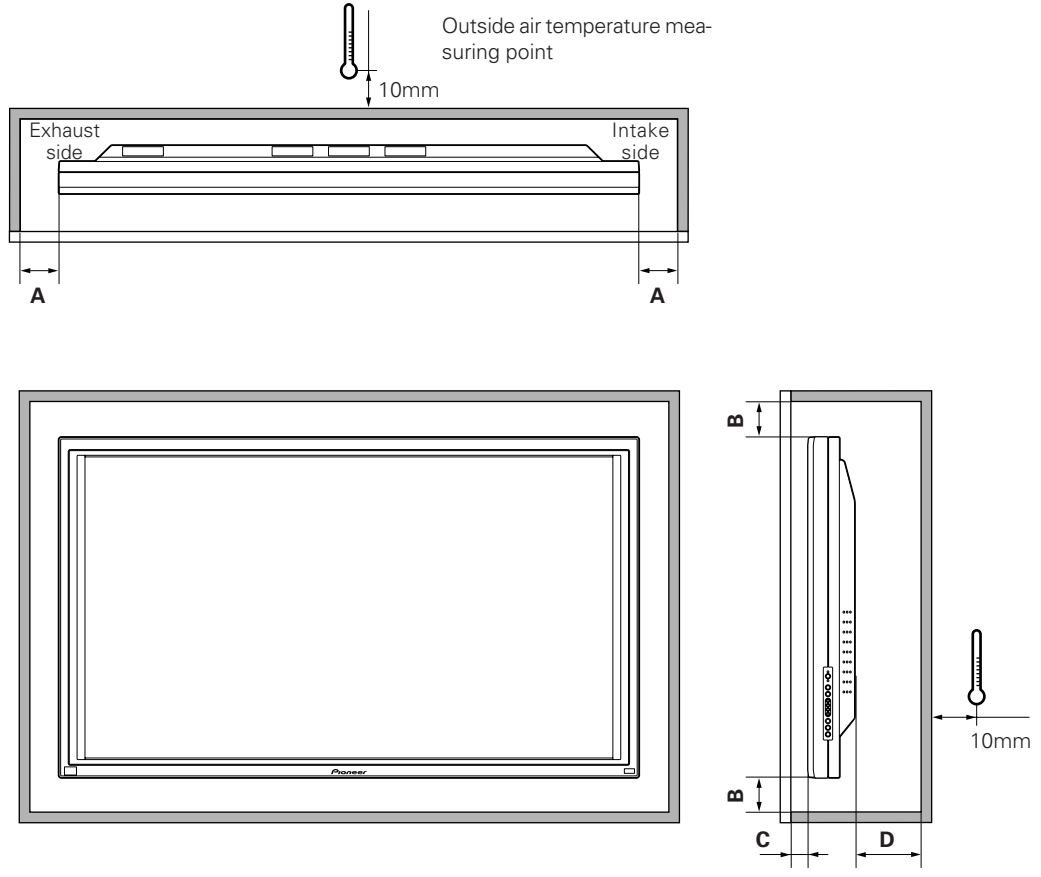

Rear view (the following area should be made of mesh)

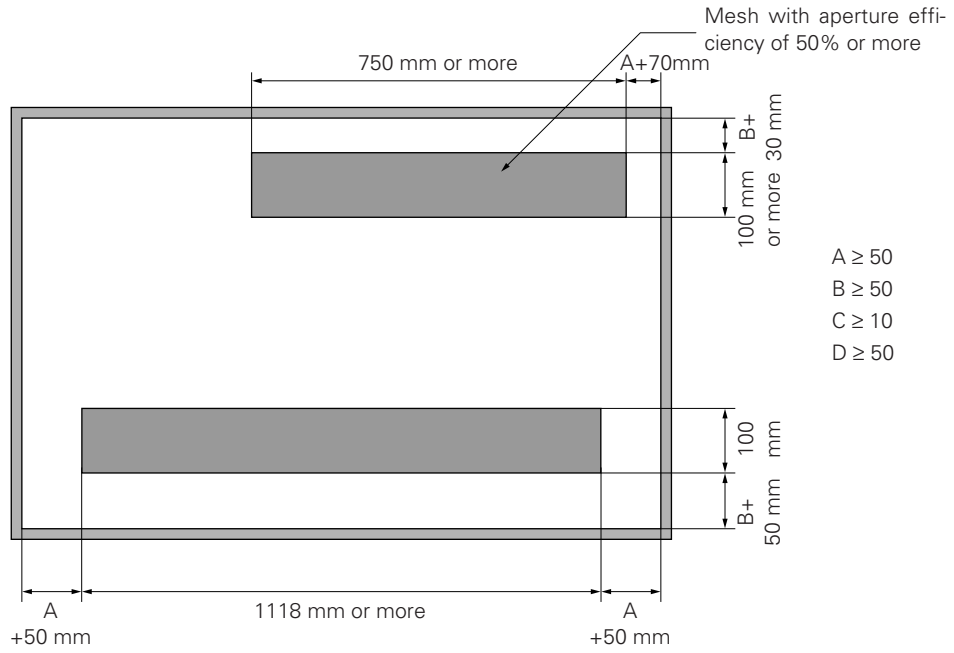

Special Installation (Ceiling suspension (with wires))

3.4.5 Ceiling suspension (with wires)

When suspending from ceilings with wire, attach the unit either at rows A and B or at rows C and D to keep it from deforming forces. In addition, the unit must be attached at four or more points, with these points distributed symmetrically on opposite sides of the vertical and horizontal center lines.

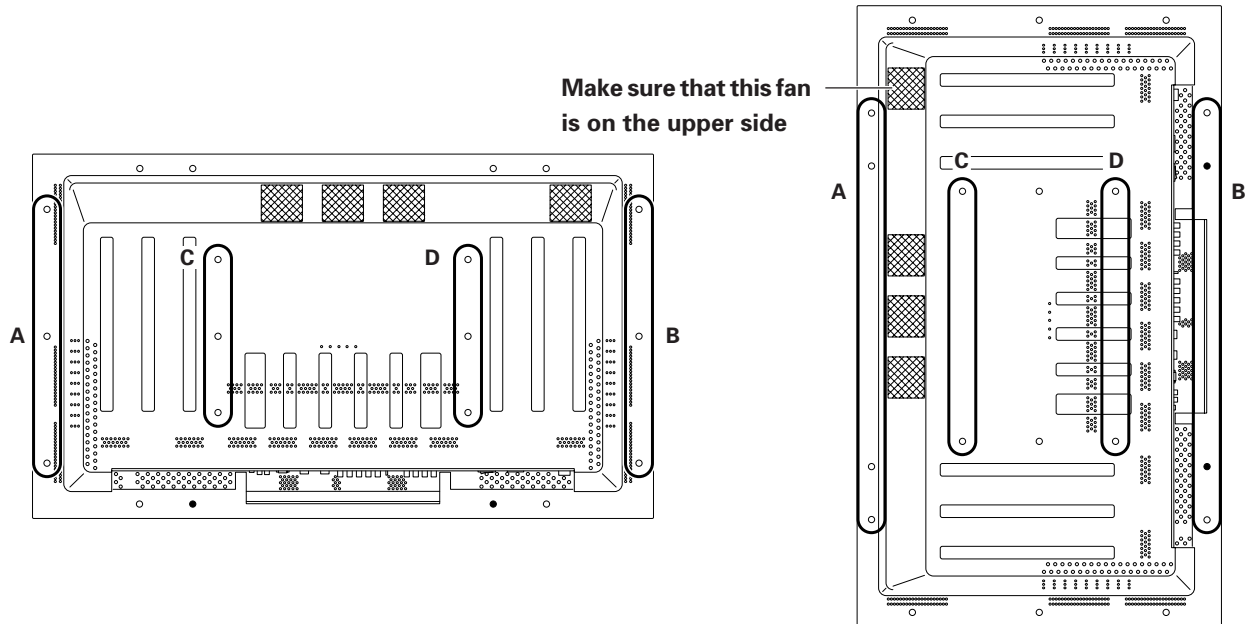

When suspending from a ceiling with wire, use the brackets shown at right to prevent concentrating loads on the upper two fixing points.

For additional safety, secure the wires to separate fittings or parts of the ceiling.

Use mounting screws of material stronger than soft steel, and use hexagonal bolts.

Use wires adequate for the combined weight of the unit 43.0 kg and the weight of the support brackets.

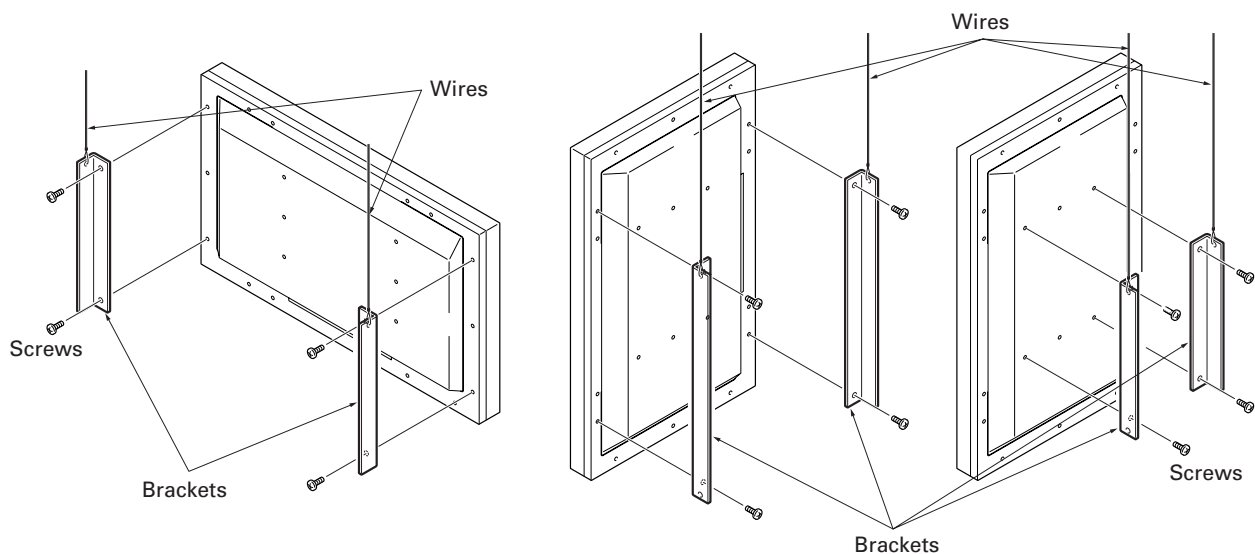

☆ Operating Temperature Restrictions

- Ambient temperature: 0 to 40 °C

☆ Operating Temperature Restrictions for Upside-Down Installations

- Ambient temperature: 0 to 40 °C

Special Installation (Ceiling suspension (with wires))

Methods of Securing: Basic methods of securing are shown below. Avoid blocking or covering areas aside from those indicated by . The methods indicated by a large X-mark must not be used. Before attaching the unit to fittings, double-check that the thickness and height of the fittings, and the number of fixing bolts is correct. (Also refer to 3.4.1 "Mounting to fittings".)

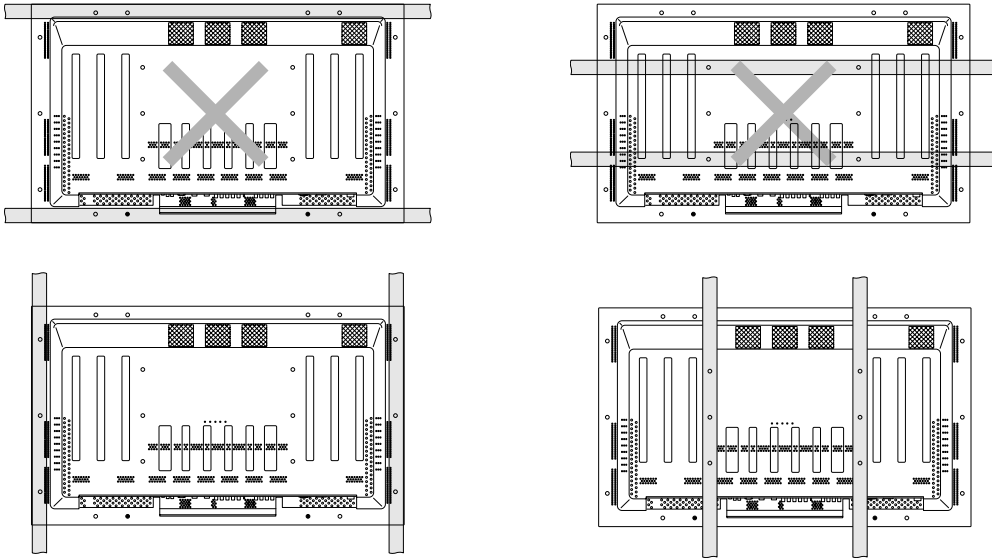

Vertical suspension

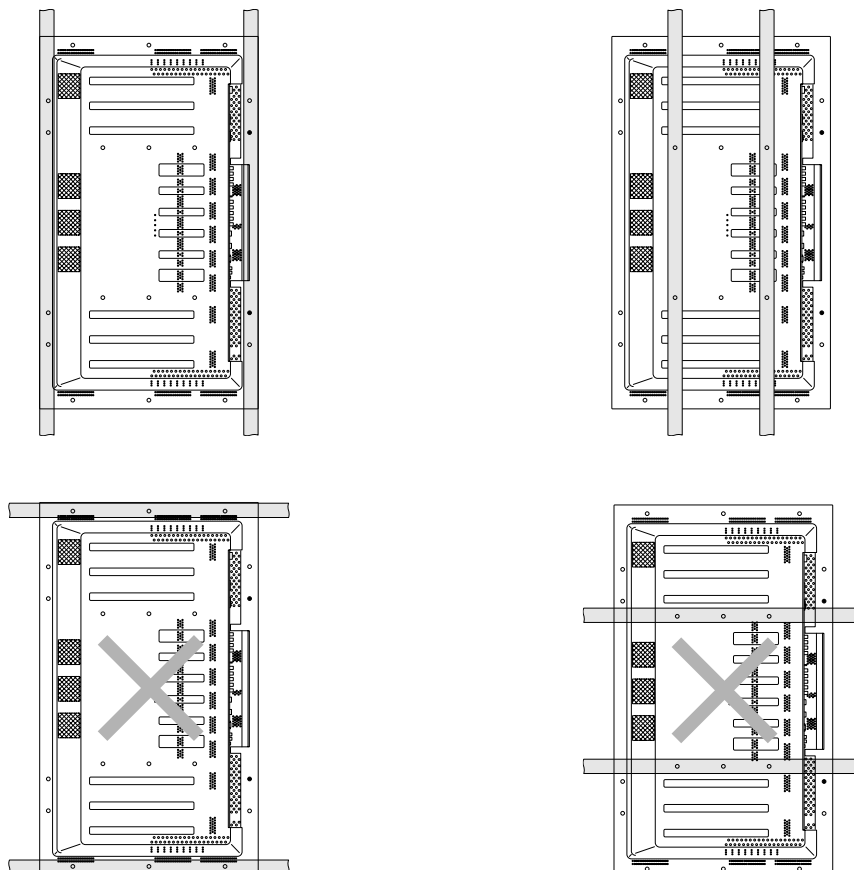

Special Installation (Hanging on the wall (lengthwise))

3.4.6 Hanging on the wall (lengthwise)

Carefully read the following before attempting to mount the unit on the wall, and observe the various limitations specified below.

Be sure to mount the unit so that twisting, bending, or any other deformation does not exceed 4 mm.

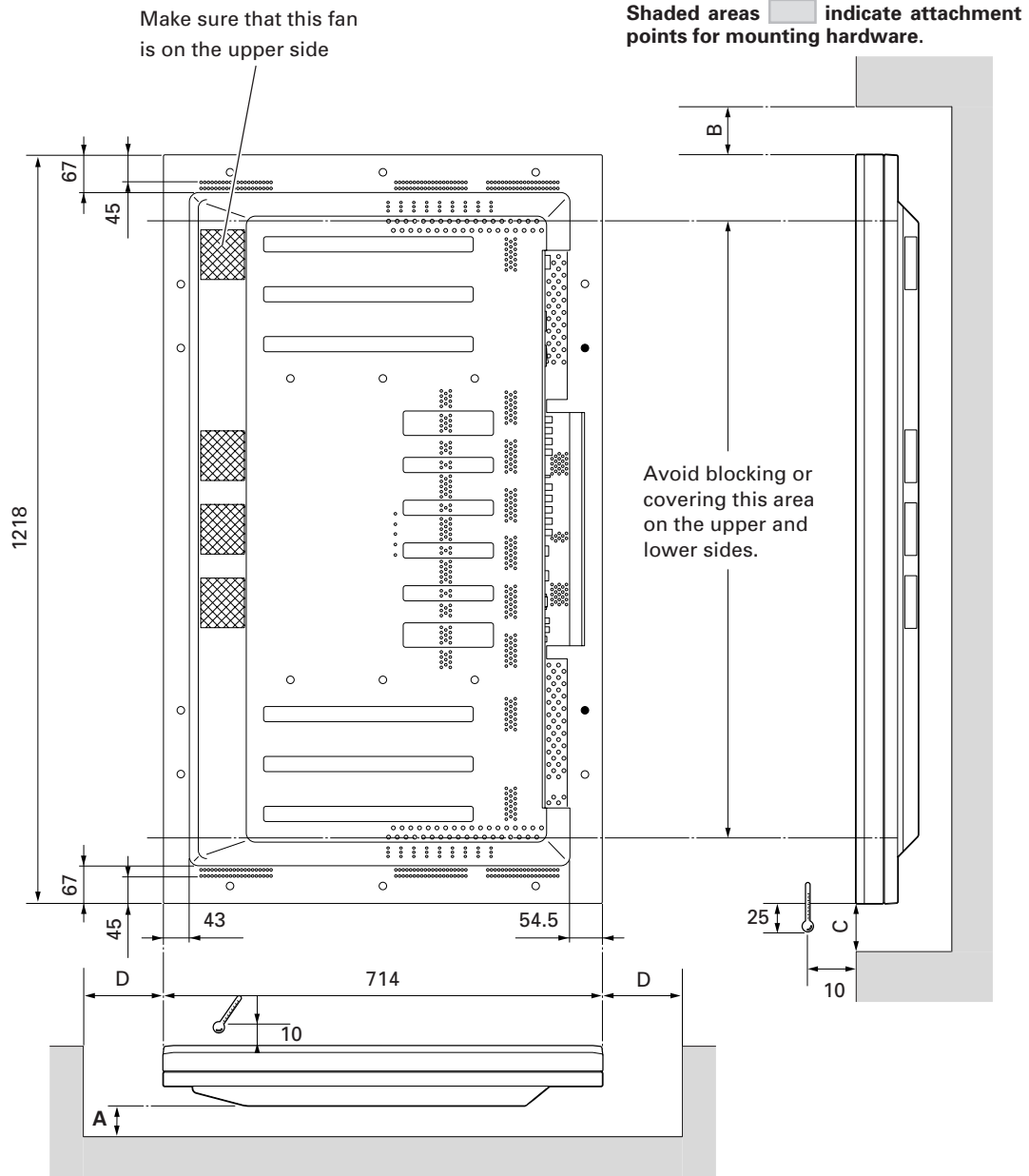

☆ Operating Temperature Restrictions

Distance from wall (A)	B	C	D	Ambient temperature
50 mm or less	300 mm or more	300 mm or more	300 mm or more	0 to 35°C
50 mm or more	100 mm or more	50 mm or more	50 mm or more	0 to 40 °C

Special Installation (Hanging from the wall (lengthwise))

Methods of Securing: Basic methods of securing are shown below. Avoid blocking or covering areas aside from those indicated by . The method indicated by a large X-mark must not be used.

Before attaching the unit to fittings, double-check that the thickness and height of the fittings, and the number of fixing bolts is correct.

(Also refer to 3.4.1 "Mounting to fittings".)

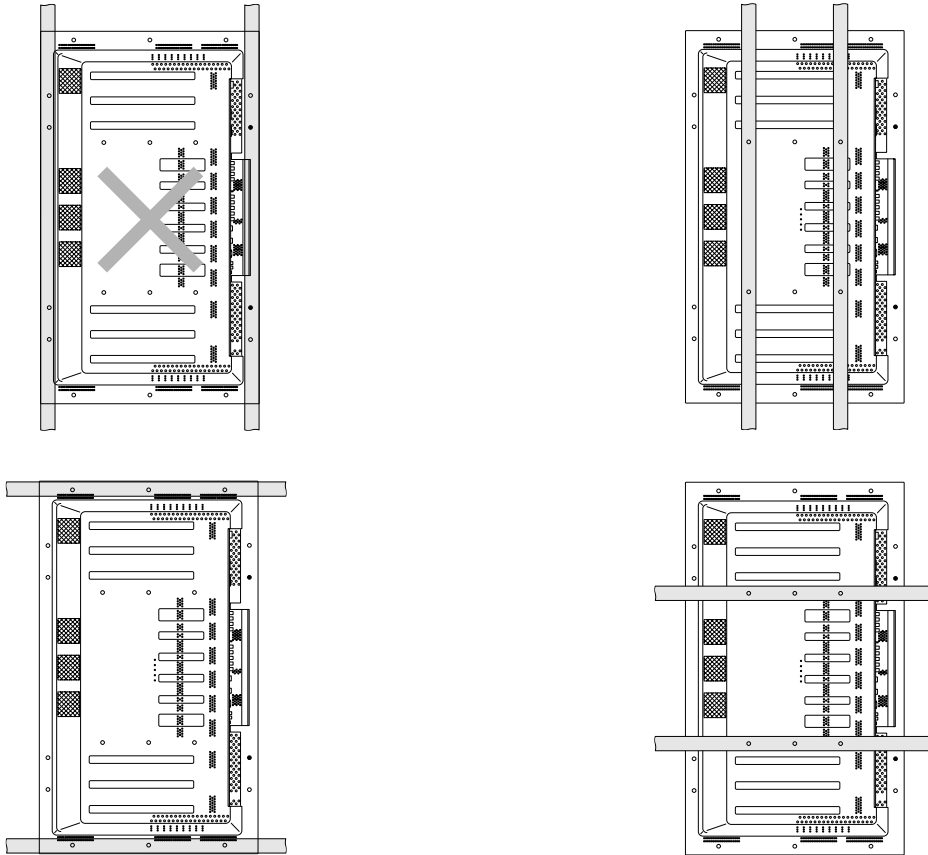

NOTE 1

Heated air is drawn off from the interior of the unit by fans. Before installation, consider the heat resistance of the wall or other surfaces behind the unit. Exhaust temperatures can be 30 °C higher than the outside temperature.

NOTE 2

For wall-mounting, do not bundle the cables in a way that will obstruct ventilation.

Special Installation (Place product upright and flush into wall (embedding in the wall))

3.4.7 Place product upright and flush into wall (embedding in the wall)

Carefully read the following before trying to embed the unit in a wall, and make sure to observe all the limitations specified below.

Be sure to mount the unit so that twisting, bending, or other deformation of the unit does not exceed 4 mm.

(1) Embedding in walls with space provided behind the unit.

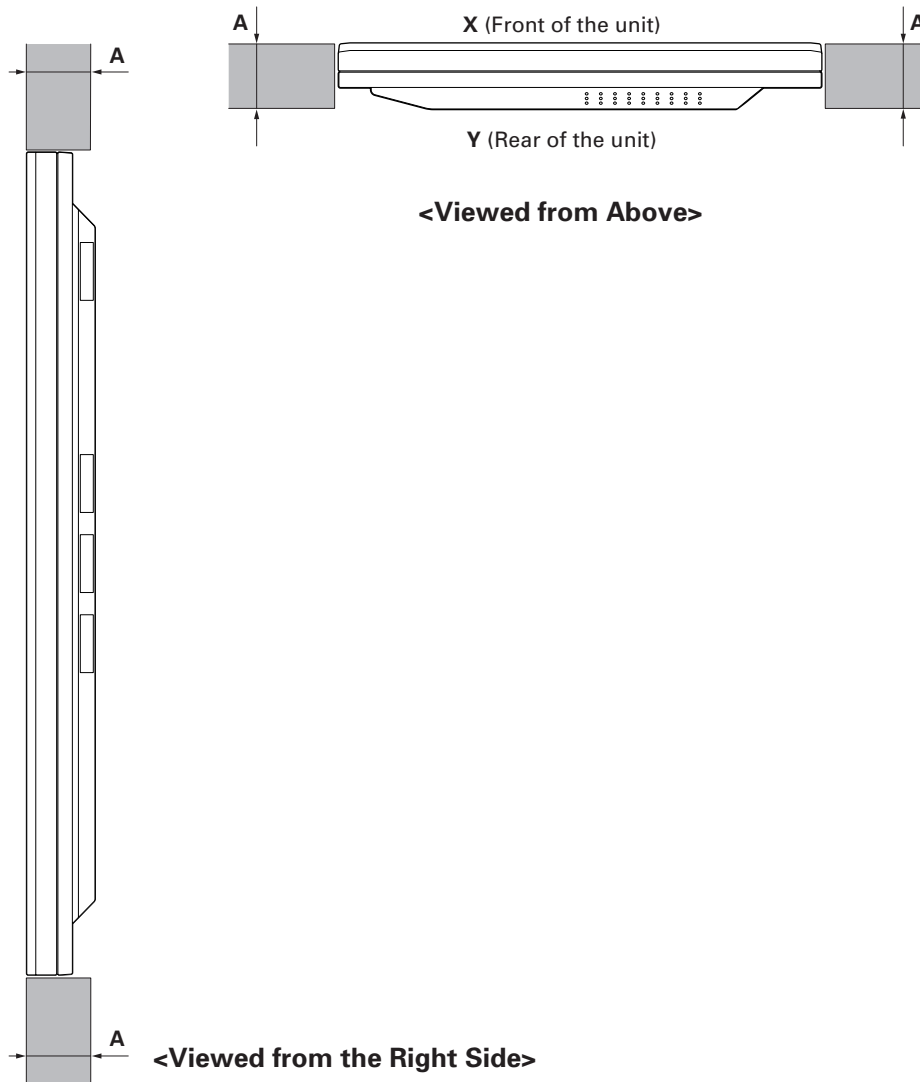

☆ Operating Temperature Restrictions

	Temperature in space X and Y
A: 0 to 370 mm	0 to 35 °C

Special Installation (Place product upright and flush into wall (embedding in the wall))

Methods of Securing: Basic methods of securing are shown below. Avoid blocking or covering areas aside from those indicated by . The methods indicated by a large X-mark must not be used. Before attaching the unit to fittings, double-check that the thickness and height of the fittings, and the number of fixing bolts is correct. (Also refer to 3.4.1 "Mounting to fittings".)

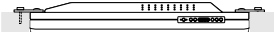
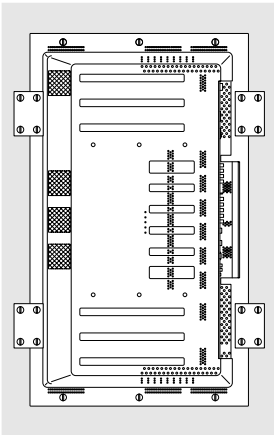
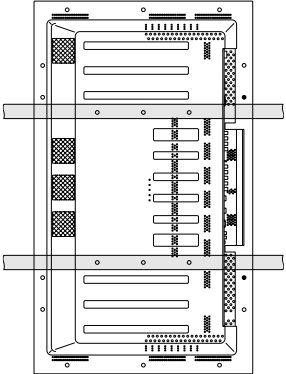
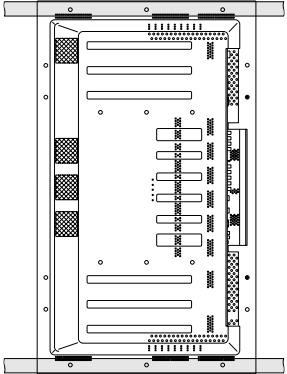
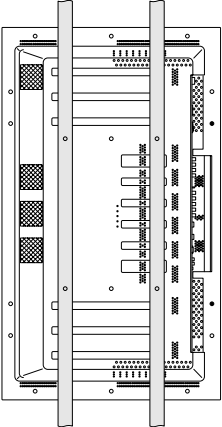
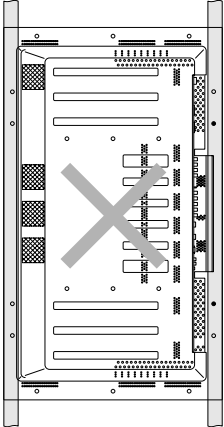

Special Installation (Place product upright and flush into wall (embedding in the wall))

(2) Embedding in walls with no space provided behind the unit.

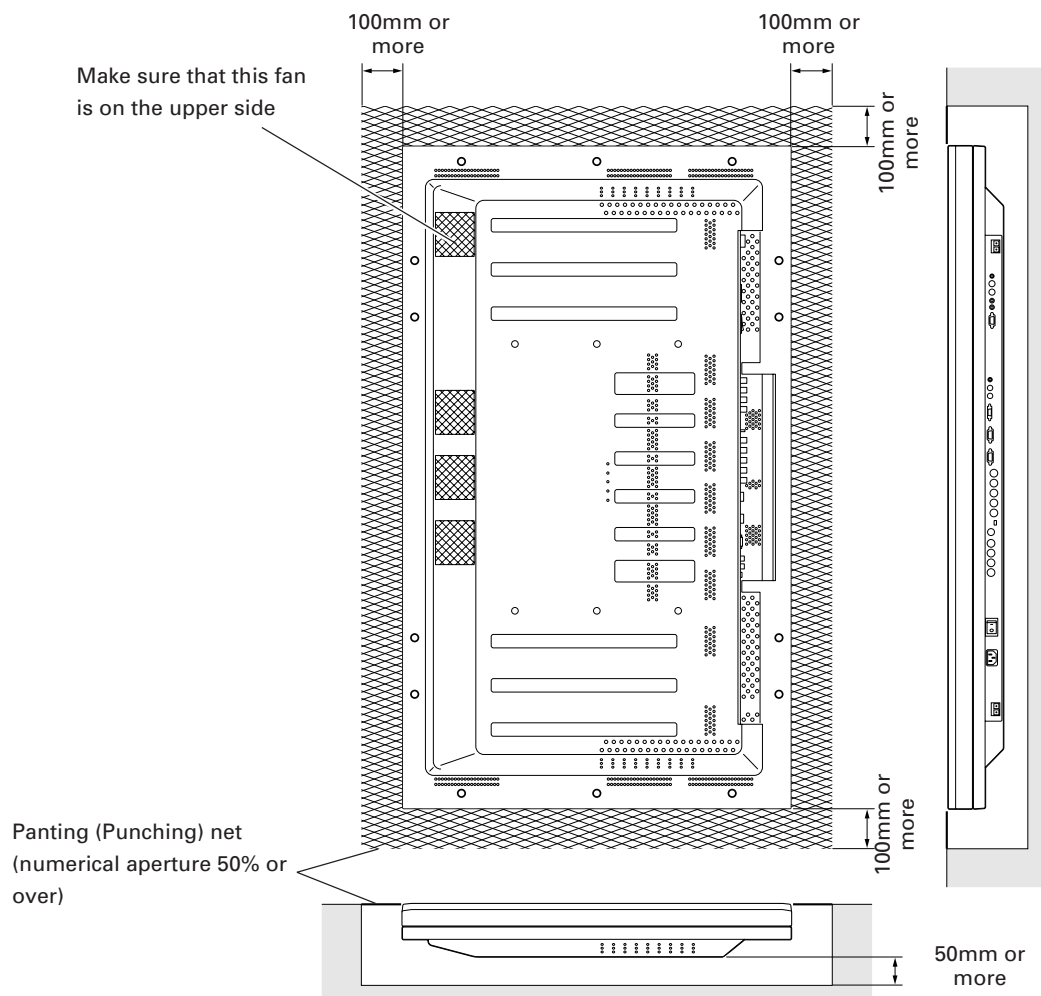

Cation : Due to possible heat up, we do not recommend installation in narrow, enclosed areas.

☆ **Operating Temperature Restrictions**

- Ambient temperature: 0 to 35 °C

Special Installation (Place product upright and flush into wall (embedding in the wall))

Methods of Securing: Basic methods of securing are shown below. Avoid blocking or covering areas aside from those indicated by [shaded area]. The methods indicated by a large X-mark must not be used.

Before attaching the unit to fittings, double-check that the thickness and height of the fittings, and the number of fixing bolts is correct.

(Also refer to 3.4.1 "Mounting to fittings".)

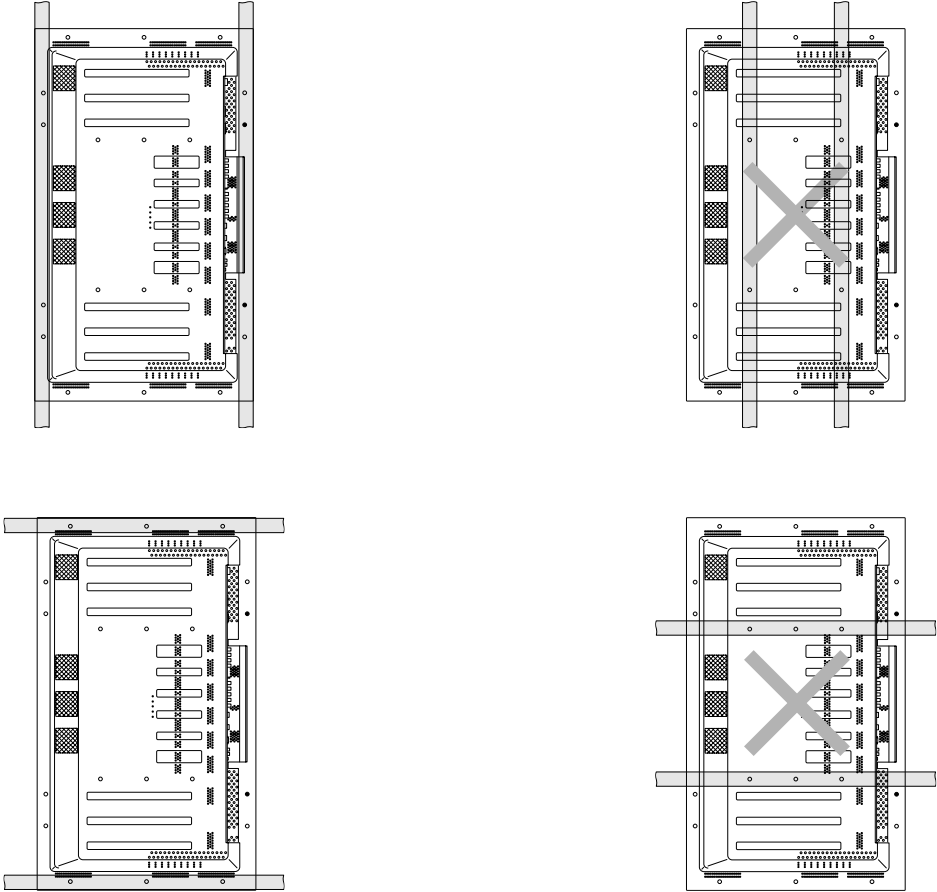

Special installation (Horizontal connections)

3.4.8 Horizontal connections

While the display is designed to accommodate side-by-side installations, keep in mind that specific installation configurations may affect ventilation. Observe the following requirements:

- ① Installation of up to two units (Horizontal connection)

The following table lists the operating temperature conditions. Use the units under conditions that keep the outside atmosphere in this range.

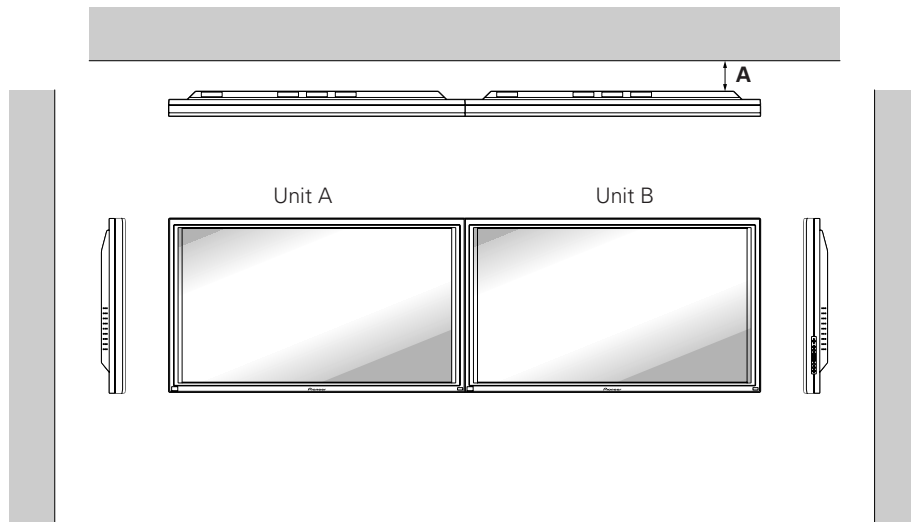

☆ Operating Temperature Restrictions

Distance from wall (A)	Ambient temperature
50 mm or more	0 to 40°C

Special installation (Horizontal connections)

② Installing three or more units (Horizontal connection)

The following table lists the operating temperature conditions. Use the units under conditions that keep the outside atmosphere in this range.

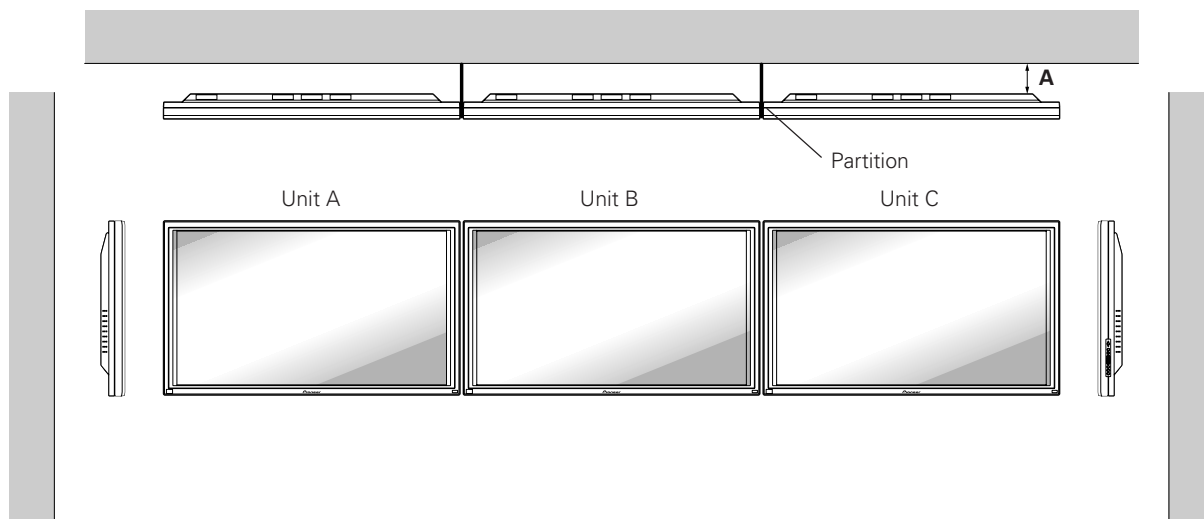

In case of lateral connections, ensure that left and right partitions are provided.

Be careful to install the partitions so that the air on the left and right backside of the set is not mixed up.

☆ Operating Temperature Restrictions

Distance from wall (A)	Ambient temperature
50 mm or more	0 to 40°C

Special installation (Multiple)

3.4.9 Multiple

While the display is designed to accommodate side-by-side installations, keep in mind that specific installation configurations may affect ventilation. Observe the following requirements:

① Inatalling multiple (2 Vertical units)

The following table lists the operating temperature conditions. Use the units under conditions that keep the outside atmosphere in this range.

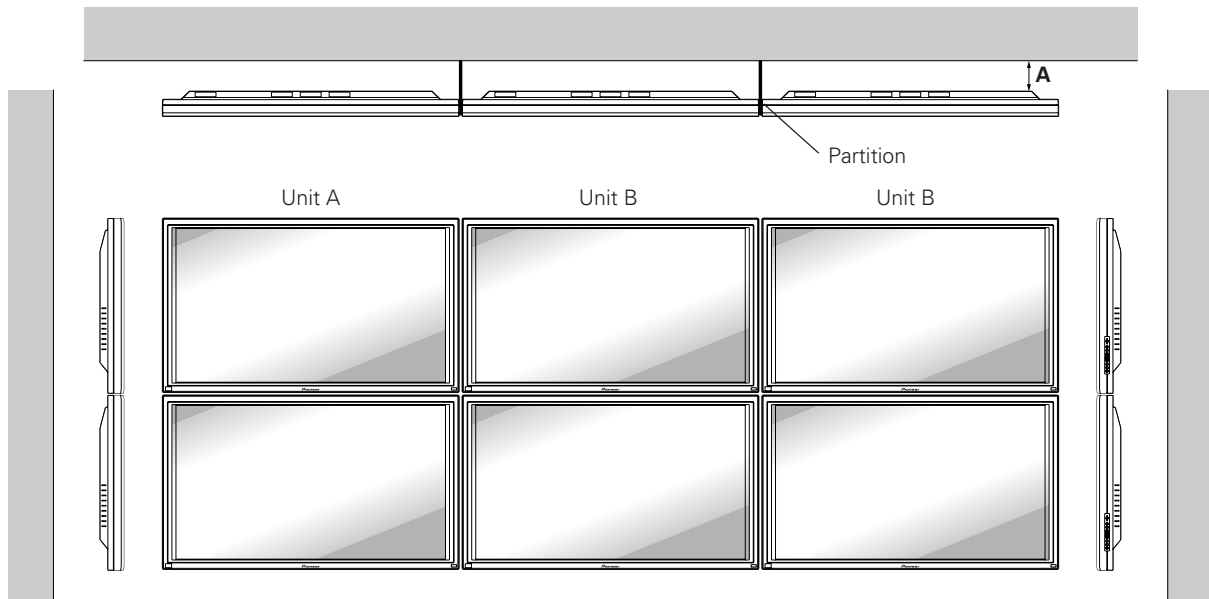

In case of lateral connections, ensure that left and right partitions are provided.

Be careful to install the partitions so that the air on the left and right backside of the set is not mixed up.

☆ Operating Temperature Restrictions

Distance from wall (A)	Ambient temperature
50 to 300 mm or less	0 to 35°C
300 mm or more	0 to 40°C

How to use the standard mounting components

4.1 Standard Mounting Components Features and Characteristics

In addition to reliability and the vivid display resulting from its large screen area, brightness, and image quality, the plasma display (PDP-502MX) is thin and lightweight, enabling mounting in locations not possible for conventional displays. We considered various mounting patterns and operating conditions during the design of the plasma display (PDP-502MX). A wide range of standard mounting hardware is available for easy mounting.

- **Table-top Stand: PDK-5001**

This on-board support designed for the plasma display enables vertical placement of the unit.

- **Plasma Display Ceiling Suspension Hardware (one-side type): PDK-5002**

Simple rod-type mounting hardware permitting display panning over a range of 45 degrees, and up to 25-degree downward tilting from the horizontal. Mount depth is 170 mm or less (in a vertical position, without optional speaker). This hardware enables installation of the unit in a wide range of locations.

- **PDP Bracket: PDK-5005**

Can be used as a handle when moving the unit, or as a frame when wire-suspending it or hanging it on the wall. Most suitable for temporary use when quick, easy, and safe attachment is necessary.

- **Tiltable wall-mount Hardware: PDK-5008**

Permits tilting of the display downward from the horizontal by up to 25 degrees. Mount depth is 125 mm or less (in vertical position, without optional speaker). This hardware permits a wide range of viewing angles.

- **Speaker system: PDP-S03-LR**

This vertical twin-speaker system, with a newly developed elliptical unit 4.5 cm wide on top and bottom with a 2.5-cm dome cone tweeter in between, provides improved sound-field localization. Despite its compact 7.4-cm cabinet, the speaker system is capable of offering powerful dynamic sound reproduction. (Note that when the speaker is mounted to the main unit itself, the operation panel of the main unit is inaccessible.)

Handling the Standard Mounting Components

4.2 Handling the Standard Mounting Components

4.2.1 Handling precautions

This section of the manual discusses ways to mount, install, and handle the mounting hardware exclusively designed for our plasma displays. Mounting should be performed by qualified experts.

Refer all installation and mounting work to qualified persons, or request assistance from a Pioneer dealer.

4.2.2 Precautions for installation contractors

1) Before installation

Observe the specifications supplied in 3.1 "Installation Site Requirements".

2) During Installation

Carefully read and observe the contents of this section of the manual.

The installation work should be performed by two or more people.

3) After installation

After installation the mounting hardware, check for adequate strength and properly tightened screws. Repeat this inspection after mounting the display.

4) Delivering to the customer

(1) Explaining mounting precautions

We ask that the mounting contractor explain the following precautions to the customer after mounting and installation work is completed. Even if the particulars of an installation are letter-perfect, your work may be perceived as inadequate unless you patiently and thoroughly explain these precautions so that the customer fully understands them.

● **The following are highly dangerous and must be avoided at all times:**

- **Any sudden application of force, including pushing and pulling**
- **Splashing water on the unit**
- **Placing any object on the unit**
- **Touching mount screws and other mounting hardware**

● **For worry-free use of the unit:**

- If any problem arises, the user should immediately ask the installation contractor to conduct inspection and repair.
- To guard against accidents, ask the customer not to make any tilt or height adjustments. Such work should be referred to the installation contractor.

(2) Mounting contractor contact form

We ask the mounting and installation contractor to complete the contractor contact form supplied with the unit and give it to the end-user after post-installation inspections are complete and the above precautions have been explained.

(3) Periodic inspections

Over time, aging of various components of the suspension/mounting hardware that are not readily visible may render the installation unreliable. This may possibly lead to the display breaking free of its mounting. Please recommend periodic inspections.

4.3 Installation of the Attachment Stand

1. Make sure to secure the attachment stand to the display platform using M8 bolts (commercially available) 25 mm longer than the thickness of the platform.

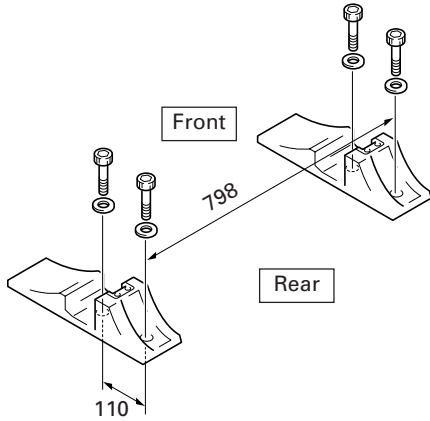

4. Insert the unit into the stand.

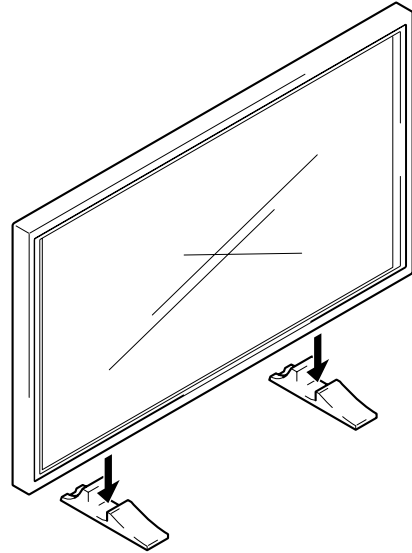

2. Insert the supplied washer into the stand.

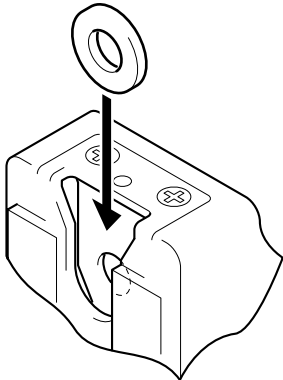

5. Tighten the bolt against the washer so as to secure the unit.

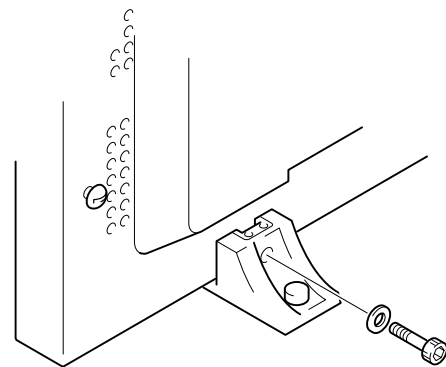

Use a 6 mm hexagonal wrench to tighten the bolt.

3. Remove the main unit's (A) and (A') hole rivets using a screwdriver or coin.

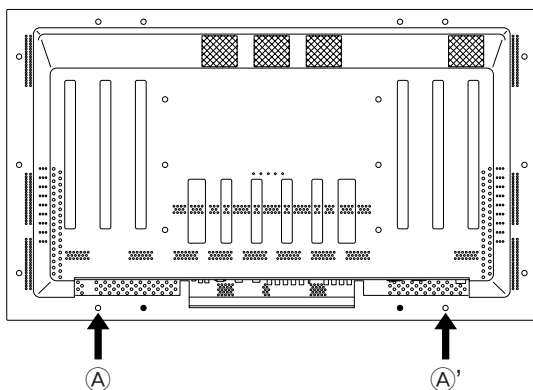

CAUTION

The unit weighs 40.3 kg., and its thinness makes it unstable. Therefore, unpacking and installation should be performed by two or more persons.

Installation of the Attachment Stand

Dimensions

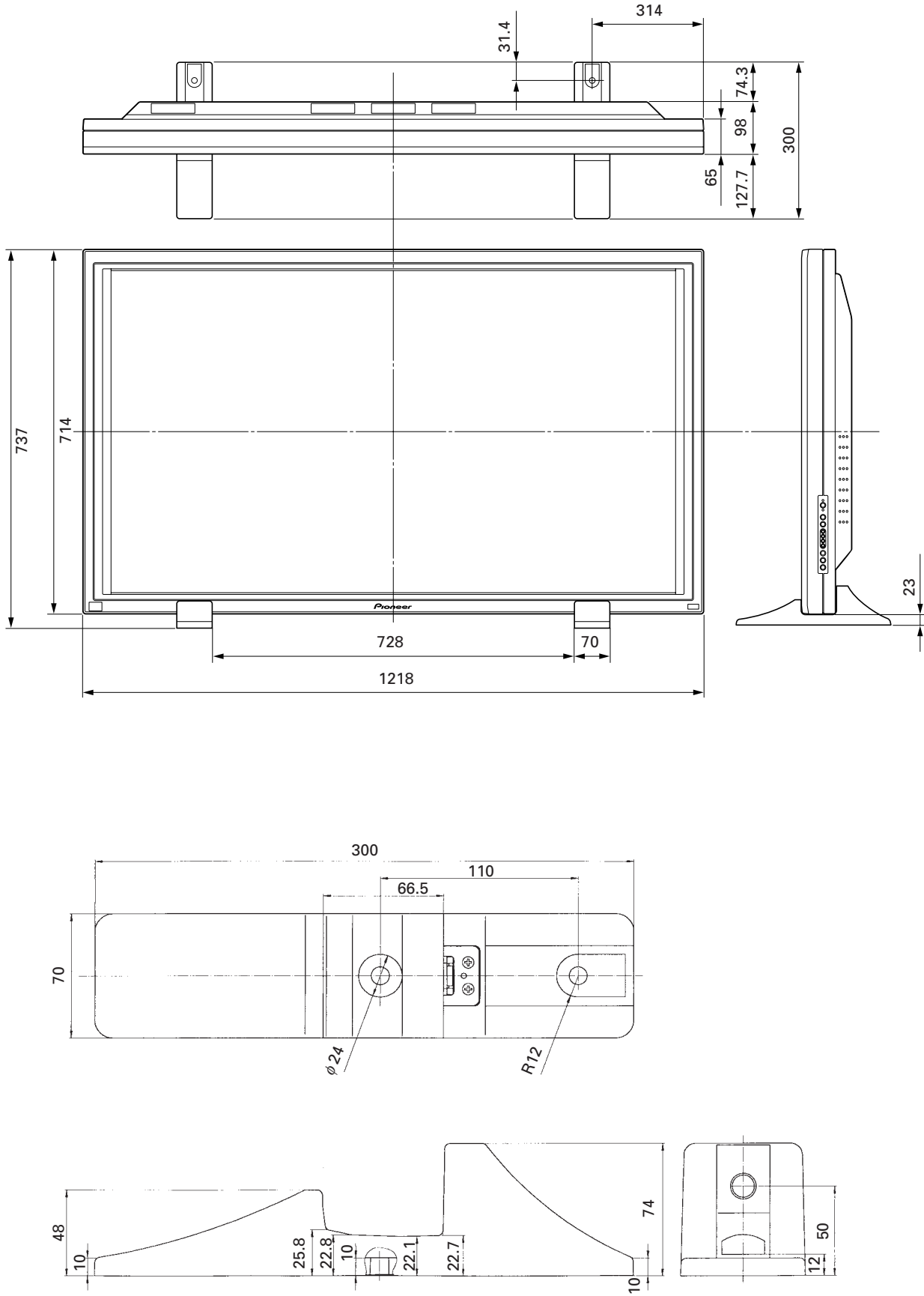

4.4 Table-top Stand: PDK-5001

4.4.1 Specifications

External dimensions	1218 (W) × 400 (D) × 765 (H) mm
Weight	4.0 kg (mounting hardware only) 44.3 kg (mounting hardware and plasma display)
Materials	Base: plastic (ABS); Stand pipes: general structural steel tubes (STK-MR)
Finish	Finish: Base: paint (Pioneer original color); Stand pipes: semi-matt black paint
Package dimensions	726 (W) × 425 (D) × 100 (H) mm
Package weight	6.6 kg

Accessories

Base	× 1
Stand pipe, L	× 1
Stand pipe, R	× 1
Vertical pipe	× 1
Screw (4 × 12)	× 6
Bolt (M6 × 40)	× 2
Cap	× 2
Hexagonal wrench	× 1
Flat washer	× 4
Mount bolt (M8 × 300)	× 4
Turning-over protective bolt	× 2
Operating instructions	× 1

☆ Operating Temperature Restrictions

- Ambient Temperature: 0 to 40 °C

☆ Operating temperature restrictions for when the speaker system (PDP-S03-LR) is attached.

- Ambient temperature: 0 to 40 °C

☆ Other factors

- Maintain sufficient clearance between the display and the wall (at least 100 mm)

Table-top Stand: PDK-5001

4.4.2 Mount locations for floor-fastening screws

* Secure the assembly to the floor using M6 screws at least 20 mm long.

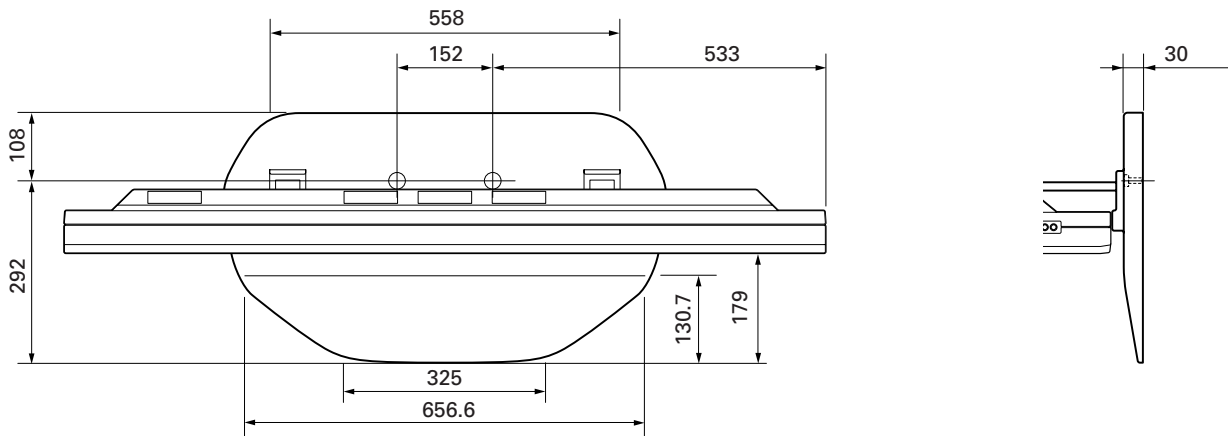

4.4.3 Dimensions (* with Plasma Display Monitor PDP-502MX installed)

Unit: mm

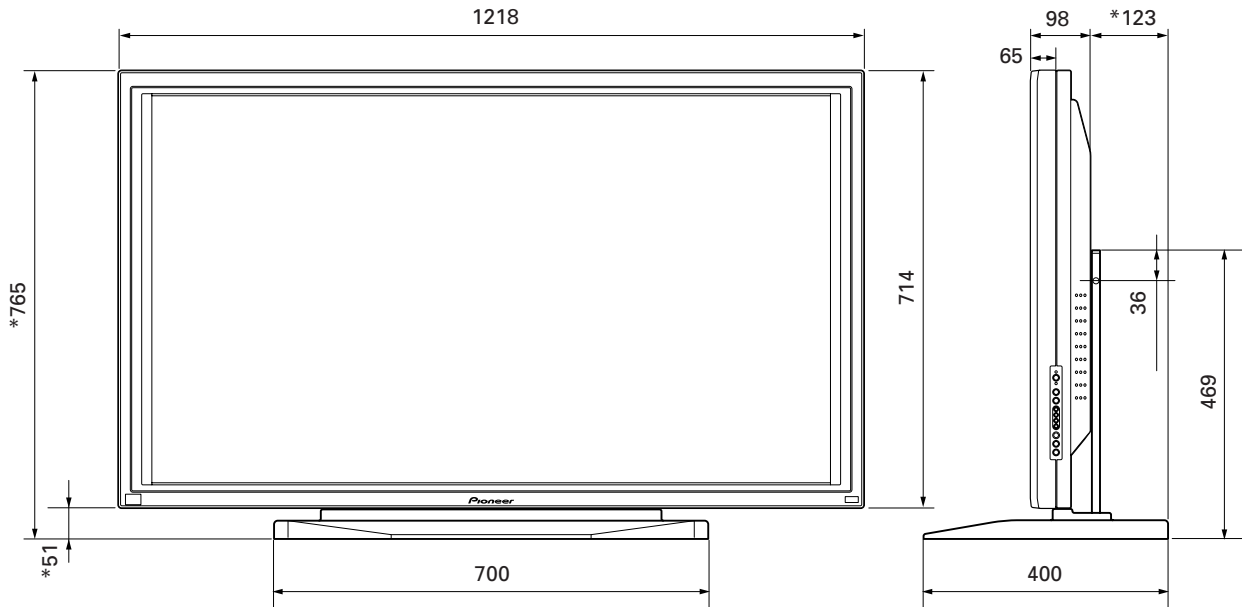

4.4.4 Assembling the stand

1) Assembling Procedure 1

- ① Place the base upside-down.
- ② Insert the left and right stand pipes into the base.
(CAUTION ⚠ : Insert pipes so that they face in the proper direction.)
- ③ Fasten the pipes to the base with the supplied screws.
(Tighten the central screws first.)

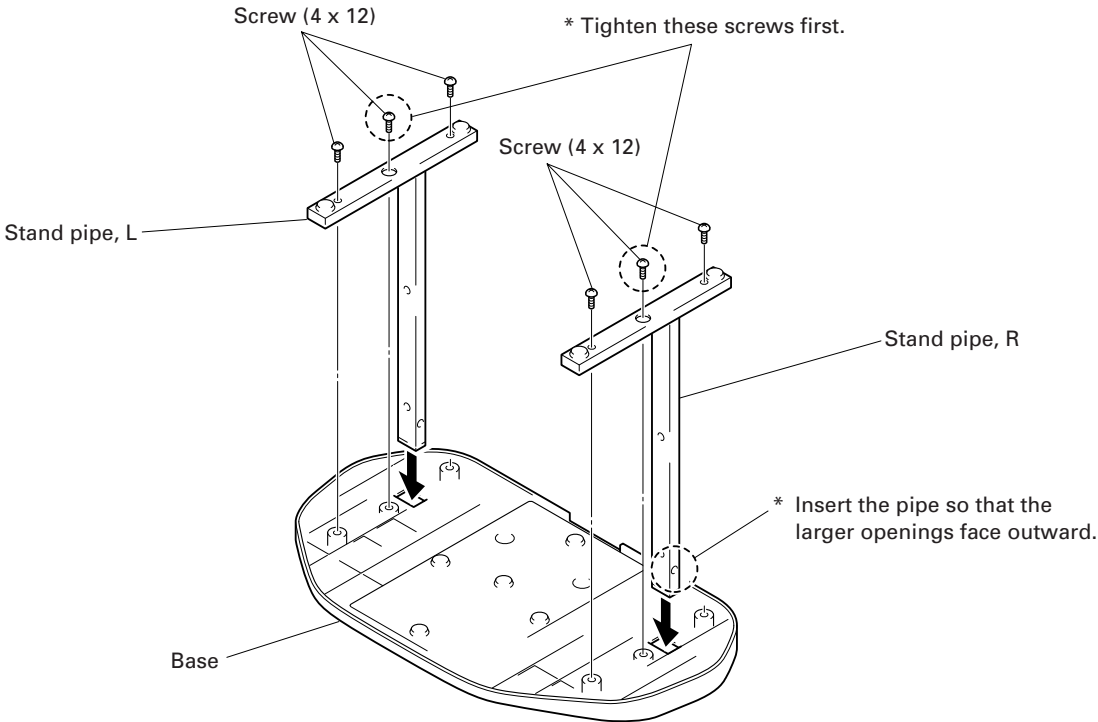

2) Assembly procedure 2

- ① Align the vertical pipe with openings in the left and right stand pipes.
- ② Tighten bolts with the supplied hexagonal wrench to secure the vertical pipe.
- ③ Insert caps into the openings in the left and right stand pipes.

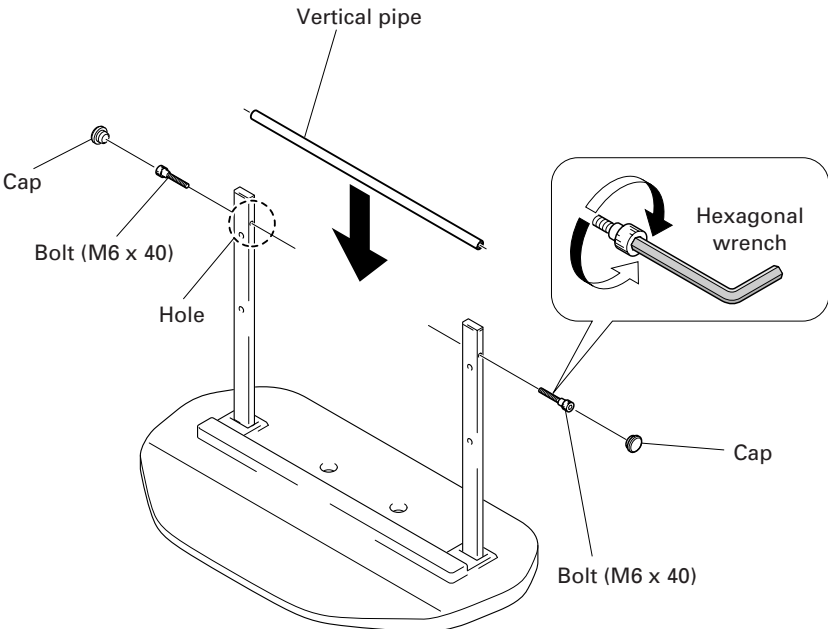

Table-top Stand: PDK-5001

4.4.5 Mounting to the main unit

1) Mounting procedures

- ① Place the display face down, remove the hole rivets, and align the assembled stand to the display mount openings.
- ② Secure the stand by tightening the washers and bolts with the supplied hexagonal wrench.



1. Lay a soft sheet beneath the display to protect it from scratches, etc.
2. The mount work should be conducted on a flat surface, such as a table.
3. Do not over-tighten bolts.
4. Align screw holes in the stand to the mount nuts found on the display as precisely as possible.
5. The unit weighs 40.3 kg., and its thinness makes it unstable. Therefore, unpacking and installation should be performed by two or more persons.

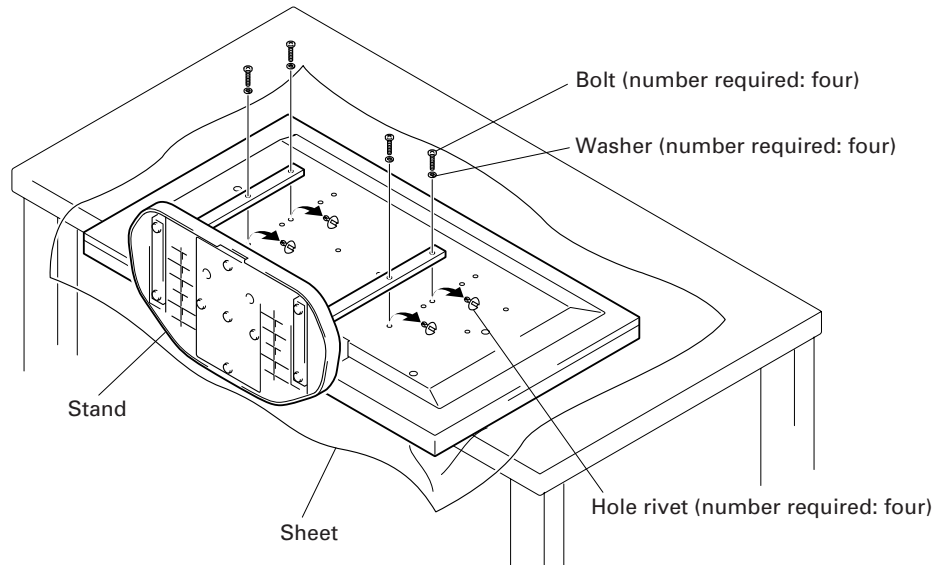

After mounting the stand to the display, fasten the assembly to the floor to prevent it from falling over.

2) Fastening to the floor

- Fasten the assembly to the floor using commercially-available screws.

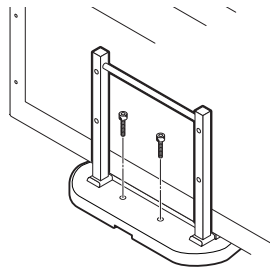

- Fasten the assembly to the floor using commercially-available clamps.

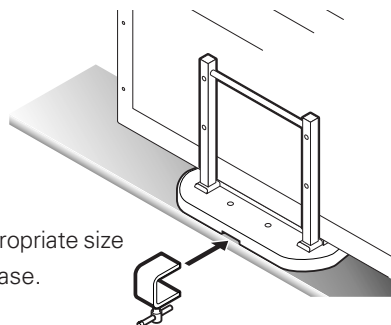

Insert spacers of appropriate size beneath the stand base.

An Alternative Method

- ① Remove hole rivets from the rear of the display.
 - ② Mount the supplied turning-over protective bolts.
 - ③ Using strings, mount the display/stand assembly to the wall or to a column.
- (Repeat the procedure for both the right and the left sides.)

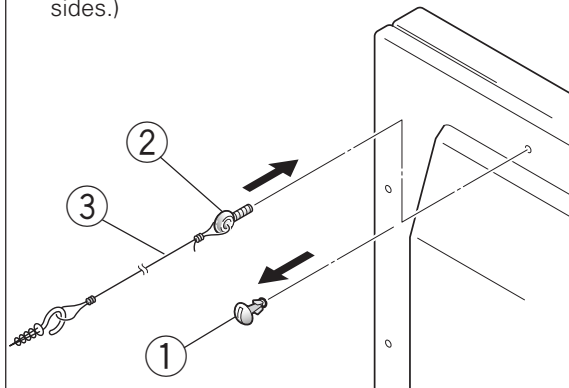

Use commercially-available strings and hooks.

4.5 Plasma Display Ceiling Suspension Hardware (one-side type): PDK-5002

4.5.1 Specifications

External dimensions	1218 (W) × 300 (D) × 1162 (H) mm (with plastic display in horizontal position)
Weight	14.6 kg (mounting hardware only) 54.9 kg (mounting hardware and Plasma display)
Adjustable range of angles	Horizontal to 25 degrees below horizontal, 45 degrees left/right
Material	Steel pipe for general structure (STK-MR)
Finish	Semi-matte black paint (Original Pioneer color)
Package dimensions	1270 (W) × 725 (D) × 230 (H) mm
Package weight	24.0 kg

Accessories

Monitor mount bolt	× 6
Flange nut	× 6
Hexagonal socket head bolt (M5 × 16)	× 1
Hexagonal socket head bolt (M6 × 10)	× 3
Hexagonal socket head bolt (M6 × 30)	× 1
Hexagonal socket head bolt (M8 × 75)	× 2
Hexagonal socket head bolt (M10 × 85)	× 2
Flat washer, ϕ 8	× 2
Flat washer, ϕ 10	× 2
Spring washer, ϕ 8	× 2
Spring washer, ϕ 10	× 2
Hole cover	× 1
Spacer	× 1
Pattern	× 1
Operating instructions	× 1
Mount contractor contract form	× 1

The appropriate types of screws and other mounting hardware will depend on the strength and composition of the ceiling. Prepare them separately.

☆ **Operating Temperature Restrictions**

- Ambient Temperature: 0 to 40 °C

☆ **Operating Temperature Restrictions for Upside-Down Installations**

- Ambient temperature: 0 to 40 °C
- Other factors: Maintain sufficient clearance between the display and the wall (at least 300 mm)

☆ **Operating temperature restrictions for when the speaker system (PDP-S03-LR) is attached.**

- Ambient temperature: 0 to 40 °C

Plasma Ceiling Suspension Hardware (one-side type): PDK-5002

4.5.2 External Dimensions

Unit: mm

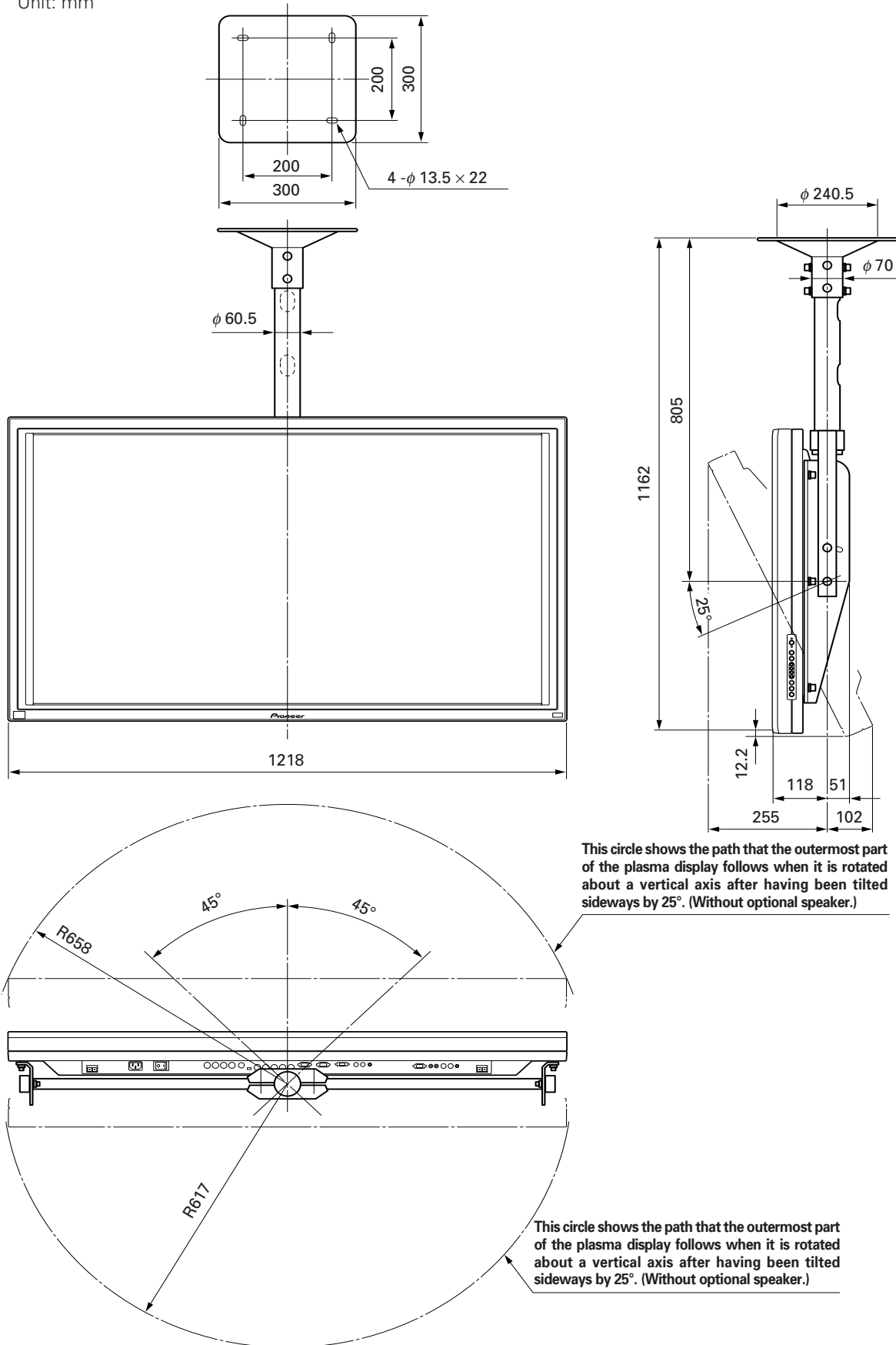

Plasma Display Ceiling Suspension Hardware (one-side type): PDK-5002

4.5.3 Assembling and Installing the mounting hardware and mounting the plasma display

1) Preparations

You will need the following tools. Make sure you have them at hand before beginning work.

- Wrench or spanner (subtense 12 mm)
- Hexagonal wrench (subtense 4 mm, for M5 bolts)
- Hexagonal wrench (subtense 5 mm, for M6 bolts)
- Hexagonal wrench (subtense 6 mm, for M8 bolts)
- Hexagonal wrench (subtense 8 mm, for M10 bolts)

You'll also need tools for ceiling work.

2) Assembling and installing the mounting software

- ① Confirm that the monitor brackets (left and right) are firmly mounted to the monitor frame. Insert the center rod through the monitor frame, and the spacer into the post COMP. Secure the post COMP and the center rod with two hexagonal socket head bolts (M8 × 75).
- ② Tighten the vibration-preventing hexagonal socket head bolt.
- ③ Select the installation site, then apply the supplied pattern to the ceiling, drill the suitable holes, and mount the ceiling flange COMP. The appropriate types of screws and other display/mounting hardware will depend on the strength and composition of the particular ceiling.
- ④ Insert the post COMP into the ceiling flange COMP and secure the two with two hexagonal socket head bolts (M10 × 85).
- ⑤ Tighten the vibration-preventing hexagonal socket head bolt (M6 × 10).
 - Firmly tight all bolts.
 - After mounting the mounting hardware but before mounting the plasma display, confirm the strength of the mount portion of the ceiling.
 - For additional safety, use the holes in the ceiling COMP flange, as shown.
[Use parts strong enough to support the weight of the display.]

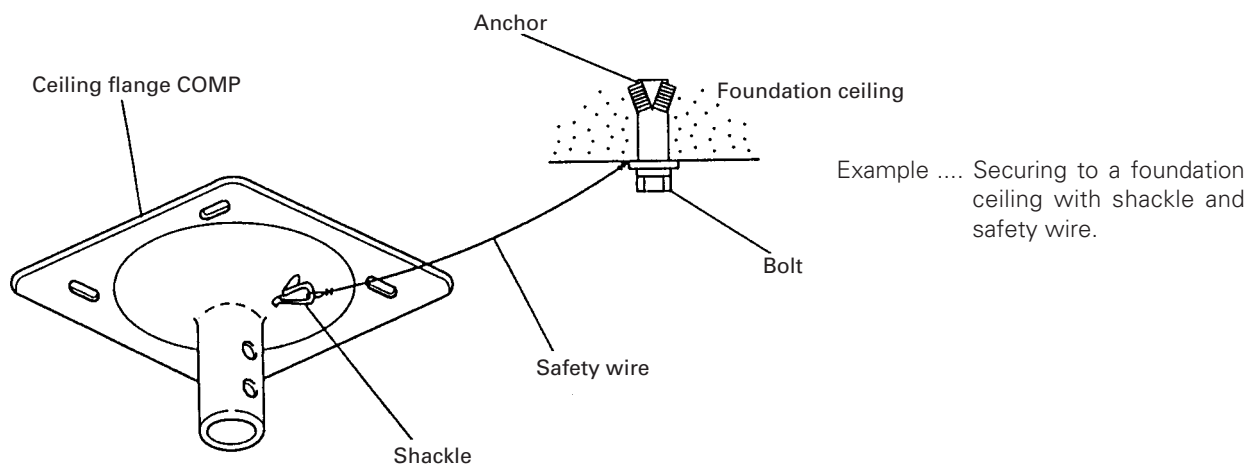

(NOTE) Safety wires serve as important backups in keeping the unit securely mounted.

Plasma Display Ceiling Suspension Hardware (one-side type): PDK-5002

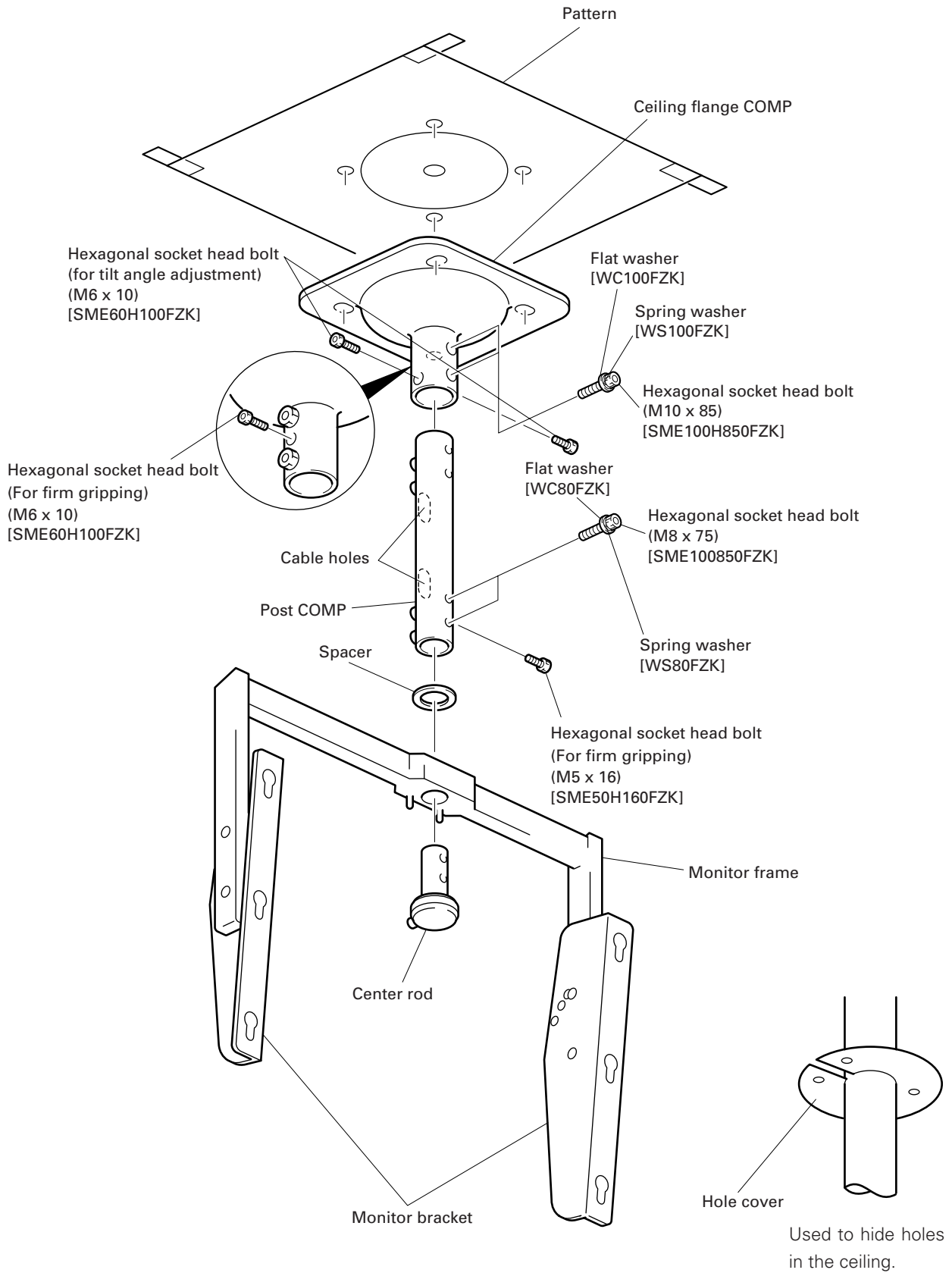

(NOTE 1) Tighten all the mount screws at the specified points.

(NOTE 2) The mounting screws must be strong enough to support the weight of the mounting hardware.

Plasma Display Ceiling Suspension Hardware (one-side type): PDK-5002

3) Mounting the plasma display

- ① Remove the hole rivets (six, in a vertical line), from the rear of the plasma display.
- ② Mount the supplied monitor mount bolt assembly (three per side) to the mount opening at the rear of the display.
- ③ Loosen the upper mount screws securing the left and right monitor brackets, and tilt the brackets to full extension. (Do NOT loosen the lower screws.)
- ④ Lift the plasma display, and insert the monitor mount bolt assemblies into the monitor brackets.
- ⑤ To avoid twisting and deforming the plasma display, always tighten the nut for the monitor mount bolt assembly (three per side) after loosening the upper mount screws of the monitor brackets.
- ⑥ Adjust the tilt of the plasma display (tiltable 25 degrees from horizontal).
Determine the desired angle, then re-tighten the upper mount screws for both the left and the right monitor brackets. Holes in the monitor brackets serve as angle marks (in 5-degree increments).
- ⑦ Adjust the left and right rotational angle of the plasma display (panning over a range of 45° on each side).
Hold the monitor frame and rotate the display to the desired angle, then secure the display assembly by tightening the vibration-preventing hexagonal socket head bolts (M6 x 30).
- ⑧ Connect cables to the display by running them through cable opening in the post COMP. If the cables are too thick to pass through the cable openings in the post COMP, connect them to the display directly, or replace with thinner cables.

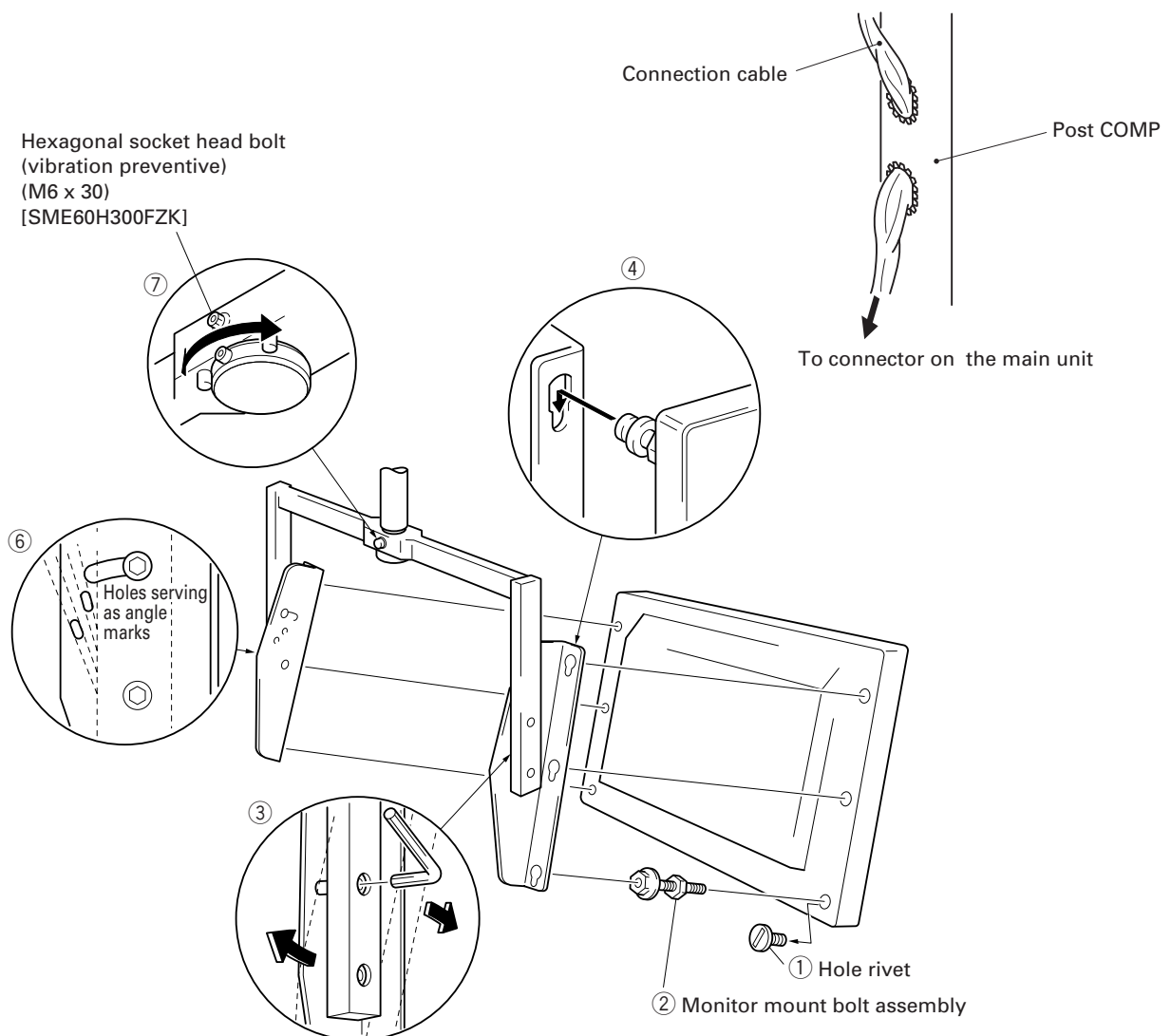

4.6 PDP Bracket: PDK-5005

4.6.1 Specifications

External Dimensions	1218 (W) × 148.5 (D) × 714 (H) (when mounted to the display)
Weight	4.1 kg (mounting hardware only)
	44.4 kg (mounting hardware and plasma display)
Material	steel pipe for general structure (STK-MR)
Finish	Semi-matte black paint (Original Pioneer color)
Package dimensions	850 (W) × 130 (D) × 110 (H) mm
Package weight	5.0 kg

Accessories

Vertical frame	× 2
Horizontal frame	× 2
Monitor mount bolt (M5 × 16)	× 4
Plus/minus screw with washer (M5 × 50)	× 8
Special eye bolt (M6 × 30)	× 4
Spring washer nut for M8	× 8
Hexagonal nut for M8 (M10 × 85)	× 8
Large flat washer for M8	× 8
Small washer for M8	× 4
Operating instructions	× 1
Mount contractor contract form	× 1

The appropriate types of screws and other mounting hardware will depend on the strength and composition of the ceiling and walls. Prepare them separately.

For the operating temperature restrictions of the unit please refer to the 'Special Installation' section

PDP Bracket: PDK-5005

4.6.2 External Dimensions

Units: mm

The mounting format is symmetrical from left to right and from top to bottom.

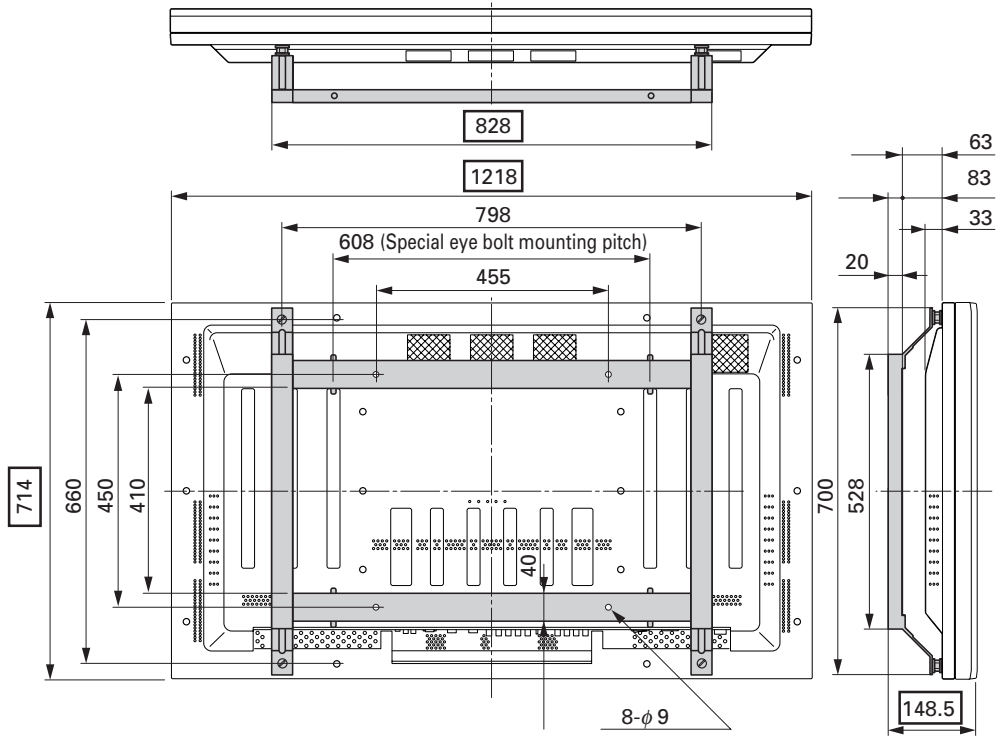

4.6.3 Assembly Procedure

① Temporarily fasten the vertical (a) and horizontal (b) frames using all of the M5 plus/minus screws with washers (e).

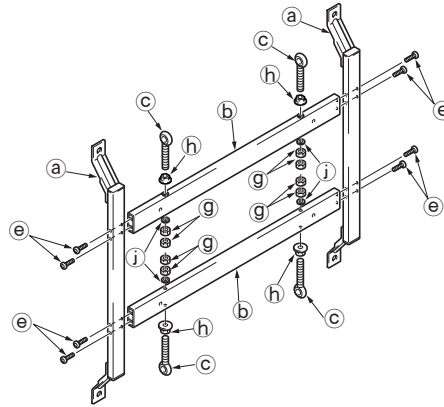

② Attach the special eye bolts (c) to the spring washers (h), and insert them into the appropriate holes. Secure the small flat washers (j) and nuts (g). (For additional safety, use double nuts.)

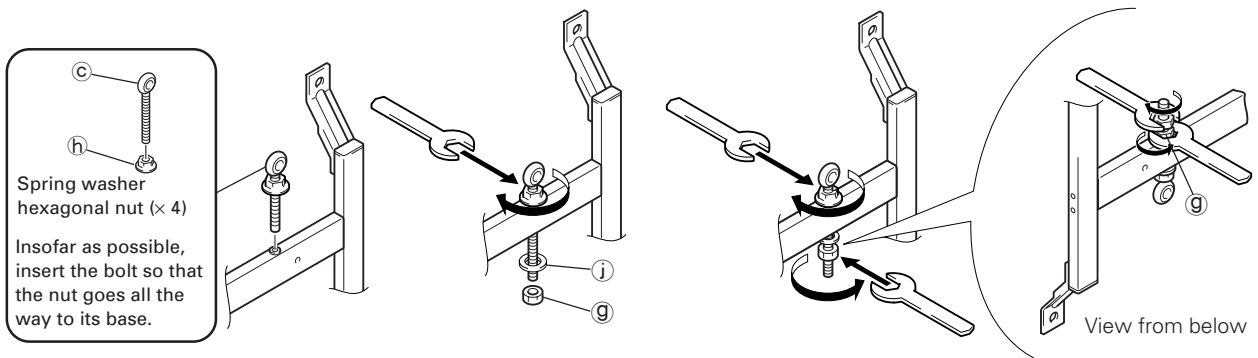

1. Attach the special eye bolts together with the M8 nuts to the main unit.

2. After passing the bolt through, secure it with the small flat washer and nut.

3. Tighten the nuts with spanners.

4. For additional safety, use double nuts. (Tighten the two nuts against each other.)



Never use special eye bolts except in the designated locations. If they are used on the plasma display itself, internal damage may result.

PDP Bracket: PDK-5005

- ③ Place the bracket on a level table or platform for the final tightening of the bolts.



The tightening the screws on the vertical and horizontal frames should be performed on a level table, as illustrated, and after the positions of the holes have been aligned.

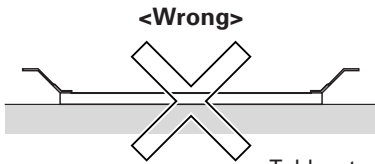

Table, etc.

If placed in this position, it will be difficult to align the holes.

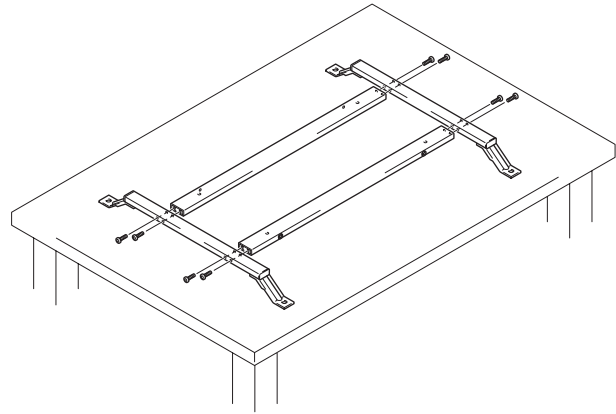

- ④ Place the plasma display face down on a secure table, as shown in the illustration, in such a way as to prevent it from falling or getting scratched.

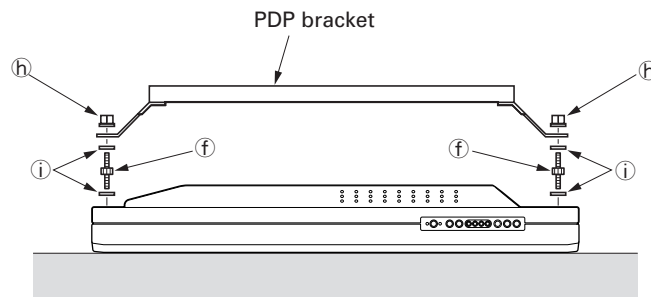

- ⑤ Place a large flat washer (i) on each of the designated holes. Tighten well the monitor mounting bolts (f) from above.
- ⑥ Place another large flat washer of each monitor mounting bolts. On top of these, mount the assembled PDP bracket.



Washers must be used. If the number and location of washers is incorrect, warping of the display unit may result.

- ⑦ As the last step secure the M8 spring nuts (h).

4.6.4 An example of use

The unit can be mounted to any of Pioneer's standard mounting hardware (with the exception of PDK-5006) while it is attached to the PDP bracket.

As illustrated, the bracket can be used as a handle for moving and installation.

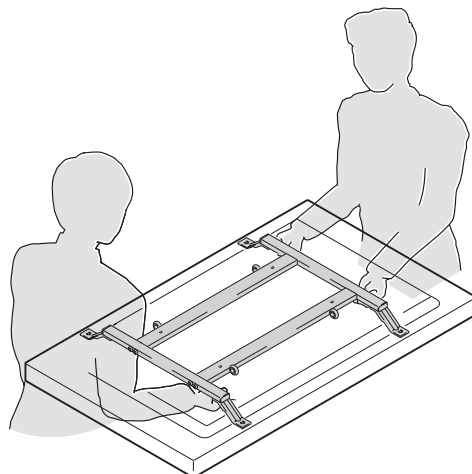

4.7 Tiltable Plasma Display Wall-Mount Hardware: PDK-5006

4.7.1 Specifications

External dimensions	1218 (W) × 125 (D) × 714 (H) mm
Weight	7.6 kg (mounting hardware only) 47.9 kg (mounting hardware and plasma display)
Materials	General structural steel tubes (STK-MR)
Finish	Semi-matte black paint on rear (Original Pioneer color)
Dimensions of packaging	1185 (W) × 270 (D) × 80 (H) mm
Package weight	8.6kg

Accessories

Vertical frame (left and right)	× 2
Horizontal frame	× 2
Hexagonal socket head flange bolt	× 8
Monitor fastening bolt (with washer)	× 8
Washer	× 4
Hexagonal wrench	× 1

☆ **Operating Temperature Restrictions**

- Ambient temperature: 0 to 40 °C

☆ **Operating Temperature Restrictions for Upside-Down Installations**

- * Upside-Down Installation is unavailable with the PDK-5006.

☆ **Operating temperature restrictions for when the speaker system (PDP-S03-LR) is attached.**

- Ambient temperature: 0 to 40 °C

In wall-mounting installation allow adequate space (a clearance of 300 mm or more) above and below the monitor set, as well as on the right and the left.

Tilttable Plasma Display Wall-Mount Hardware: PDK-5006

4.7.2 External Dimensions

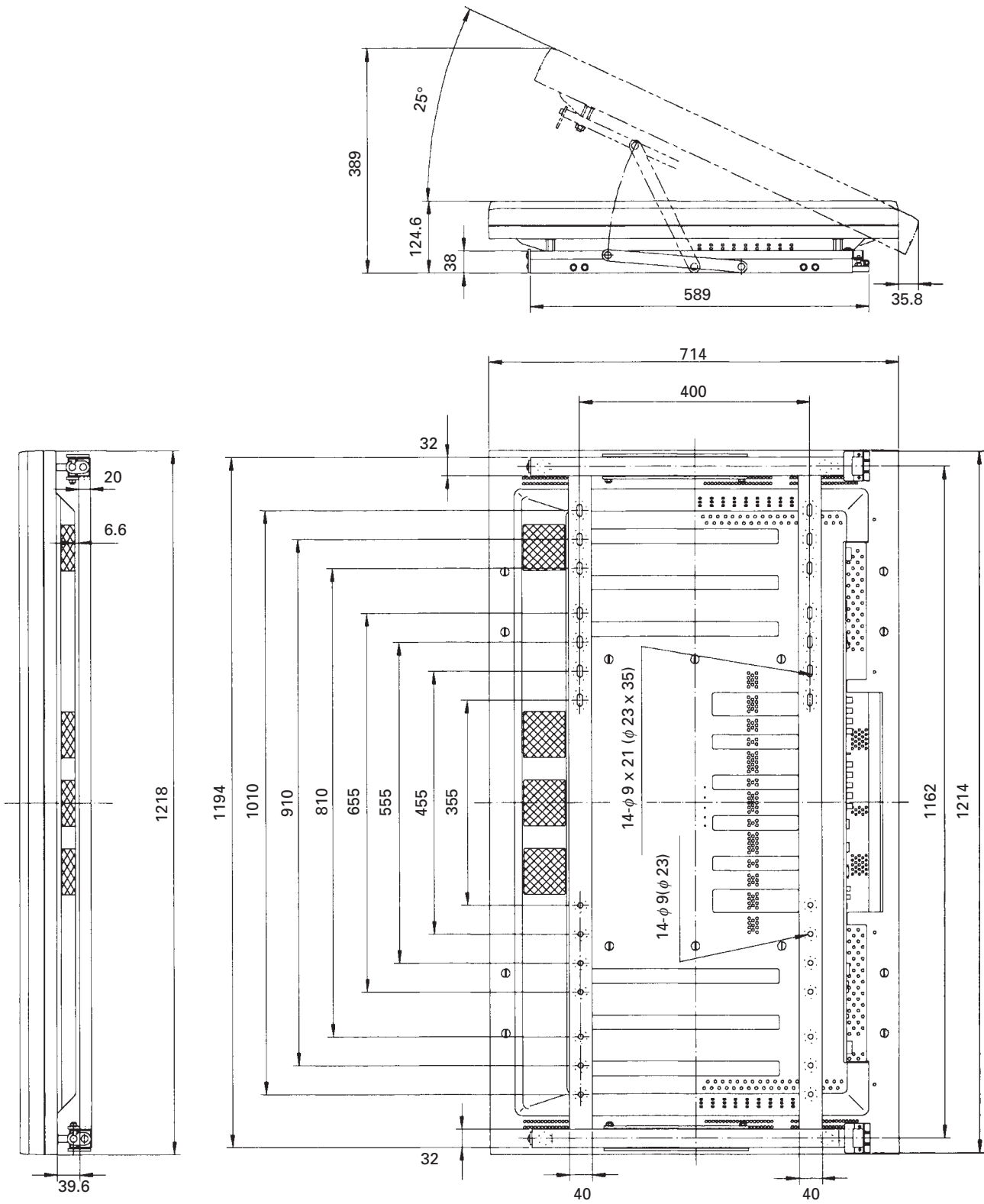

4.7.3 Assembling the mounting hardware and mounting the plasma display

1) Precautions before assembling

- Make sure you distinguish correctly between the vertical frames for right and left. Both should be mounted so that their hexagonal sockets face outward.
- The horizontal frames should be mounted so that their smaller openings face the wall. A total of eight openings are provided in the horizontal frames for wall-mounting. (A total of fourteen openings are provided in the PDK-5006 itself.)

2) Assembly procedure

- ① Loosen screw (a) and separate one end of the hook from the screw.
- ② Hold the upper part of the vertical frame and open to an approximate width of 10 cm.

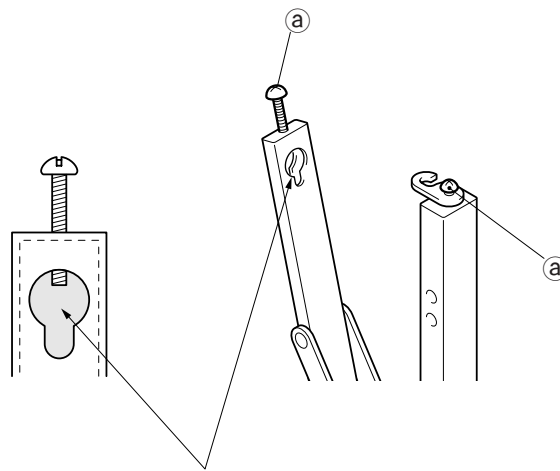

Loosen the screw until you can no longer see its end through this opening.

- ③ Mount the horizontal frame to the vertical frames.

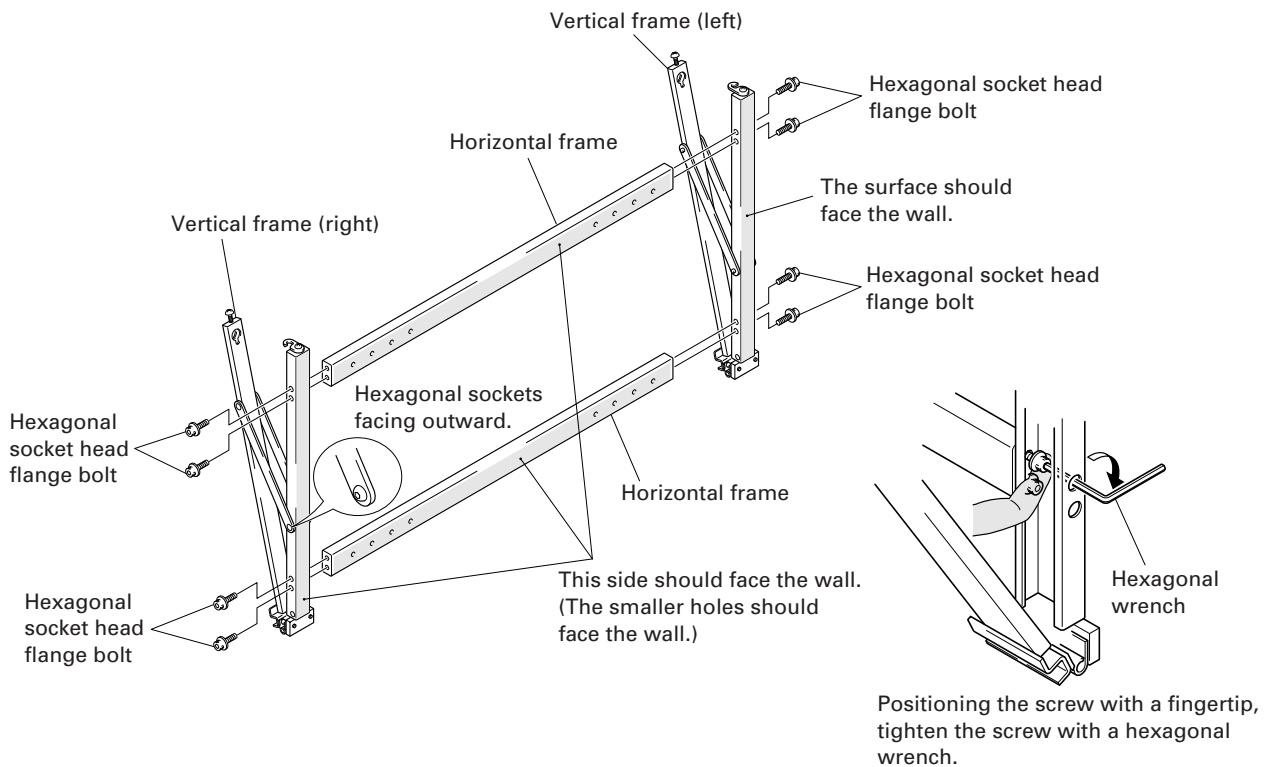

Tiltable Plasma Display Wall-Mount Hardware: PDK-5006

3) Mounting the monitor-fastening bolts to the plasma display

- ① Mount the monitor-fastening bolts to the four rear corners of the plasma display.

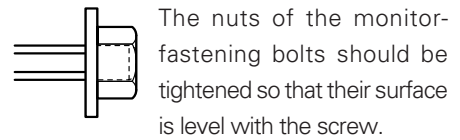
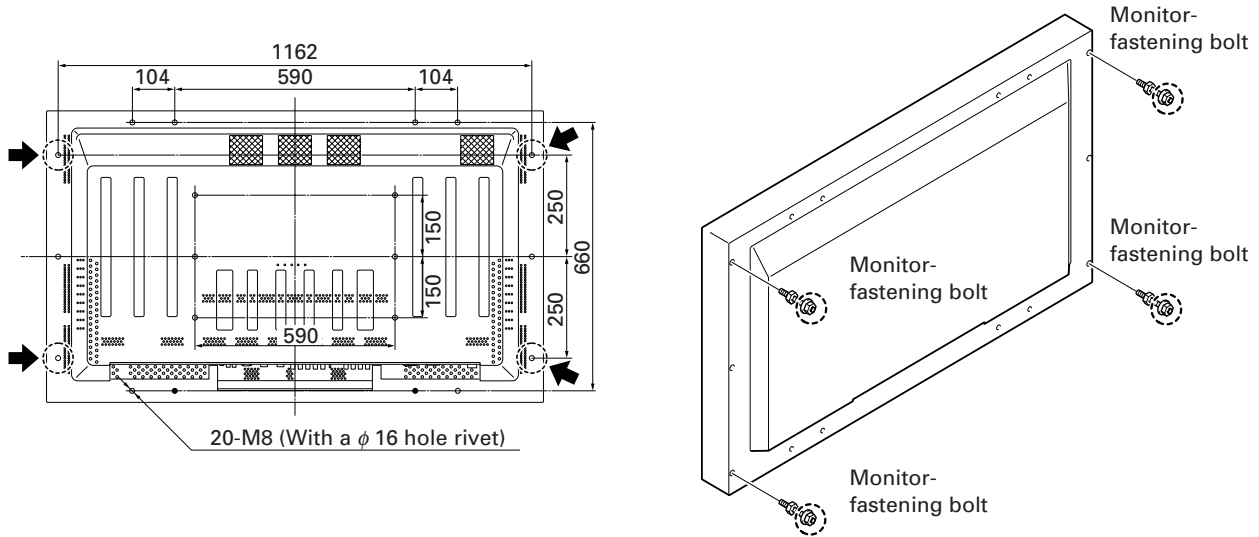

- ② Mounting the assembled mounting hardware to the wall.

1. Firmly fasten the mounting hardware to the wall at a minimum of four points (b), using appropriate screws or bolts. Make sure that the screws and bolts are appropriate for the wall's strength and composition.

CAUTION

Before mounting to the wall, check that the fittings have adequate strength.

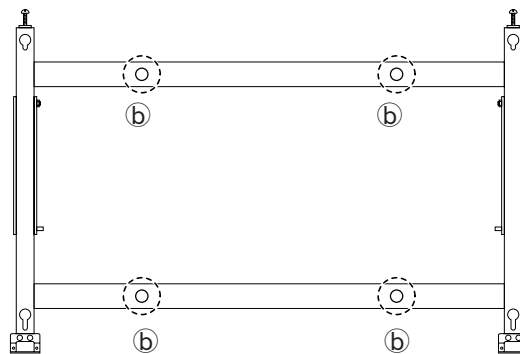

Tiltable Plasma Display Wall-Mount Hardware: PDK-5006

2. After mounting the mounting hardware to the wall with screws, fully extend the left and right vertical frames as shown, and tighten the left and right screws (C).

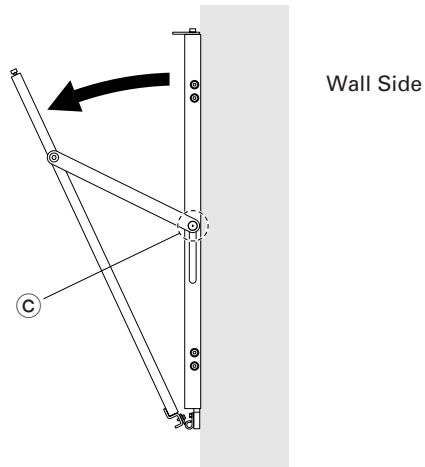

③ Mounting the plasma display

1. Two persons should firmly hold the left and right sides of the display, as shown. Insert four monitor-fastening bolts into the appropriate openings in the wall-suspension hardware. Insert the two lower bolts before the upper two.

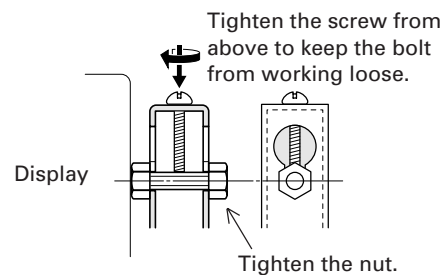
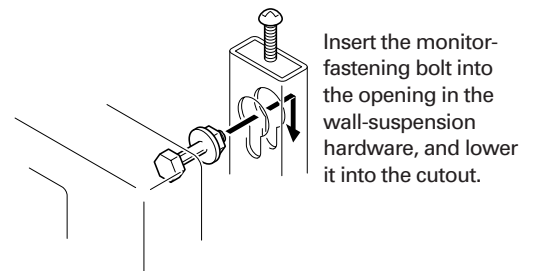
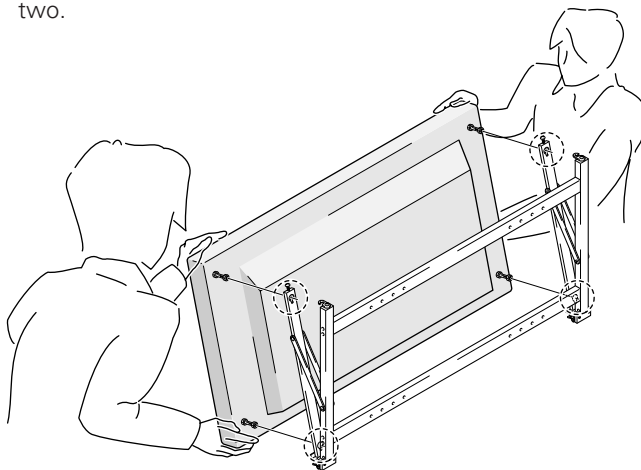

2. After performing the above step, adjust the installation angle, as discussed on the next page.

Tiltable Plasma Display Wall-Mount Hardware: PDK-5006

4) Adjusting the angle

This mounting can be tilted 25 degrees, without set increments.

The work should be done by two people.

- ① Loosen screw © on the left and right vertical frames.
- ② While sliding the arm down, push the display to the desired angle.
- ③ Once the desired angle is reached, tighten screw © on the left and right frames.

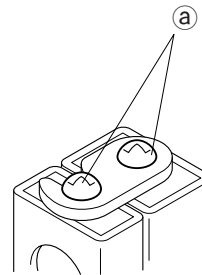
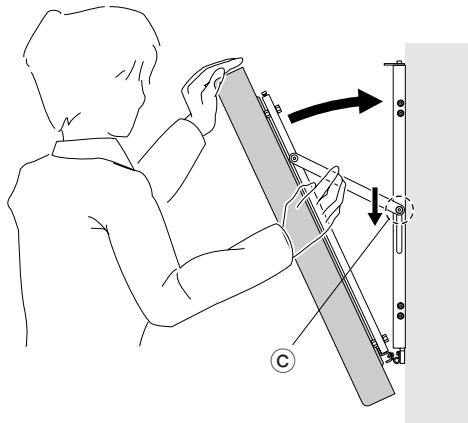

When mounting the display flush or parallel to the wall, secure the movable and fixed portions of the mount frame by tightening the screws ①, as shown. This prevents accidental tilting of the display. You must also tighten the left and right © screws.

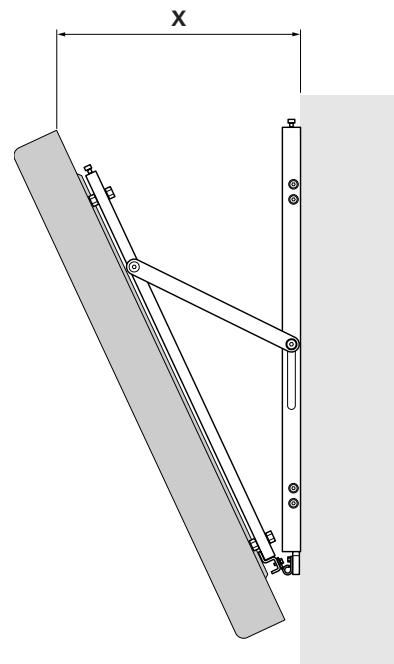
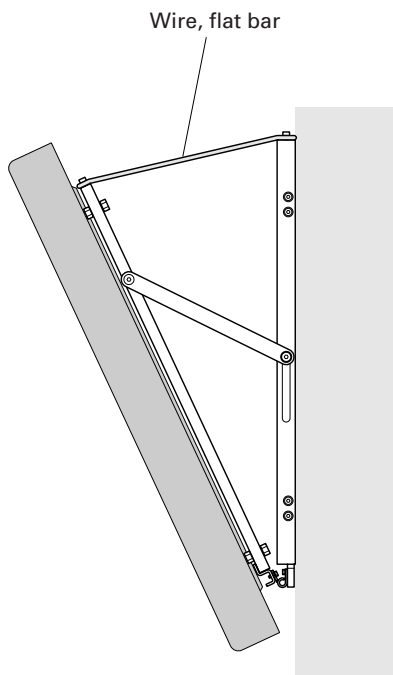

After mounting the unit at an angle, an additional reinforcement measure can be taken by attaching an appropriate wire and a flat bar using screws ①.

When the angle is set to less than 5°, please secure using wires or a flat bar etc.

Measuring the opening distance X enables approximate angle values to be determined.

X	Angle
181 mm	5°
236 mm	10°
290 mm	15°
341 mm	20°

4.8 Carriable Stand: PDK-5008

4.8.1 Specifications

External dimensions	1218 (W) x 720 (D) x 1710 (H) mm
Weight	36.5 kg (stand only) 76.8 kg (stand and plasma display)
Materials	STKM (steel pipe) SPCC and SS41
Finish	Melamine baking finish (silver metallic)
Dimensions of packaging	1704(W) x 900(D) x 105(H) (main support) 978(W) x 770(D) x 255(H) (bracket part) 705(W) x 400(D) x 75(H) (shelf part)
Package weight	31.5kg (main support) 12kg (bracket part) 4.5kg (shelf part)

Accessories

Panel support	× 1
Bracket	× 1
Leg base	× 2
Shelf board	× 1
Shelf Board Mounting Hardware	× 2
Hexagonal wrench	× 1
Hexagonal socket head bolt (M8 × 70)	× 4
Hexagonal socket head bolt (M8 × 20)	× 8
Ornament screw (M6 × 12)	× 4
Washer	× 4
Flat head spring washer	× 4
Leg base collar	× 4
Cord clip	× 6

☆ Operating Temperature Restrictions

- Ambient Temperature: 0 to 40 °C

☆ Operating temperature restrictions for when the speaker system (PDP-S03-LR) is attached.

- Ambient temperature: 0 to 40 °C

4.8.3 Mounting procedures

For the sake of safety, this operation should be performed by two or more persons.

- ① Attach the panel support to the leg base.

Attach the support post using hexagonal socket head bolts (M8 × 70) and leg base collars, as shown, so that the label in the rear is facing in the direction of the rear casters.

*Use the binder clips to secure the power cord, computer connector cable, BNC terminal cable, etc.

(NOTE) In order to ensure that the bolts are safely tightened, tighten them twice or more, alternately.

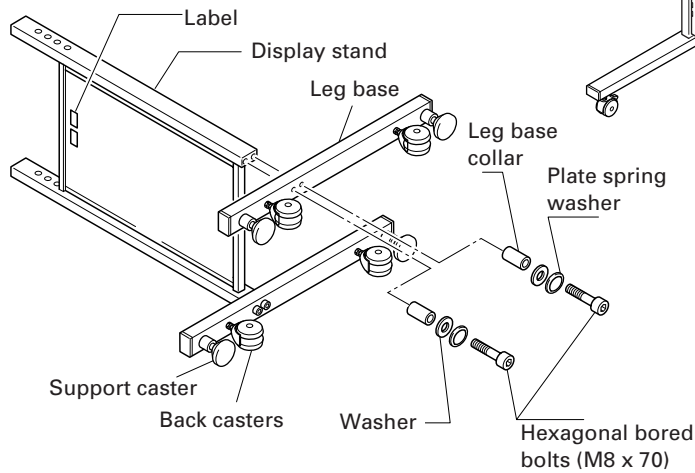

- ② Attach the cord clip to the display stand.

*The cord clip is designed for use in binding together power cables, computer cables, or BNC terminal cables.

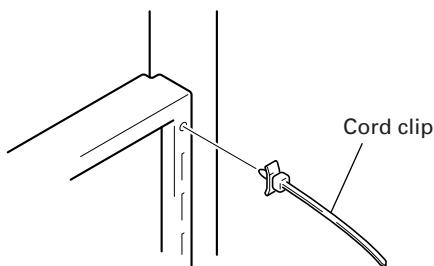

- ③ Mount the bracket support bolts on the support panel.

Mount hexagonal socket head (M8 × 20) to the panel support, leaving a 5 to 6 mm gap, as shown.

(There are three mounting levels available, such that the center of the display's screen is 1350, 1125, or 1100 mm, respectively, from the floor.)

(NOTE) Don't mount to the fourth opening from the top. It will be used in step 4, if the highest level mounting is employed.

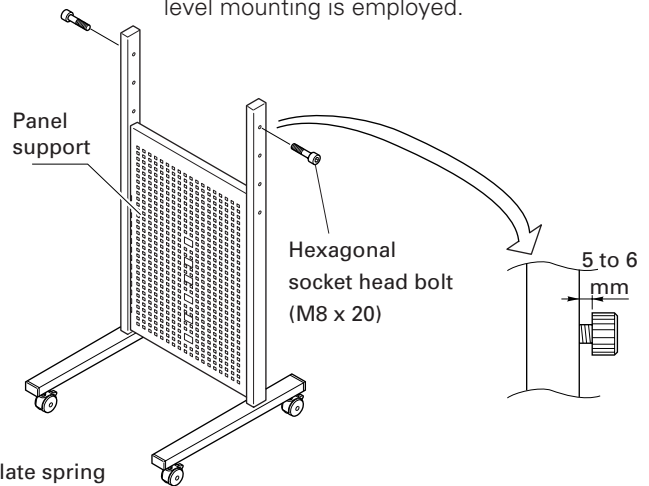

- ④ Mount the plasma display on the bracket.

Using hexagonal socket head bolt (M8 × 20), attach the bracket to the screw openings in the rear of the plasma display, as shown.

(NOTE) We advise that you spread a blanket or soft cloth to prevent scratching of the front of the plasma display.

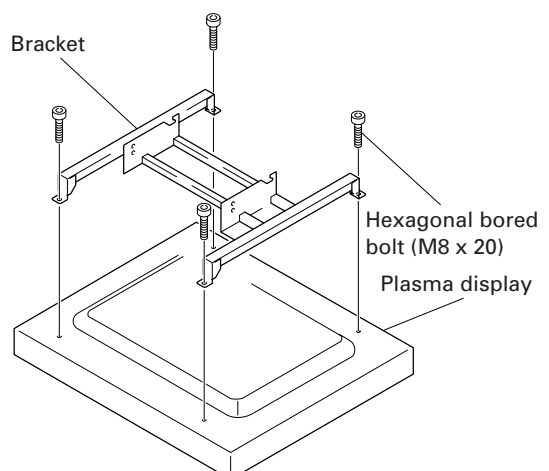

Carriable Stand: PDK-5008

⑤ Mount the bracket-mounted plasma display onto the panel support.

1. Hook the bracket hooks onto the bolts protruding from the left and right of the panel support.
2. Fasten the screw openings under the hooks to the screw openings on the left and right of the panel support, using hexagonal socket head bolts (M8 x 20), as shown.
3. Tighten the hook bolts.

(NOTE 1) This operation must be performed by two or more persons.

(NOTE 2) In order to ensure safe installation, always be sure to alternately tighten each bolt two times or more until they are firmly fixed in place.

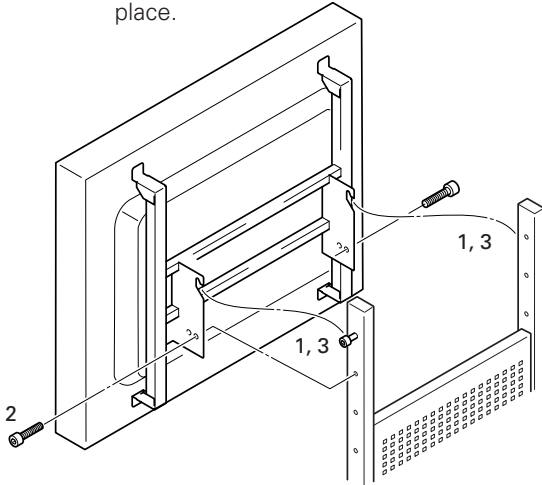

[Adjusting the angle of the plasma display screen]

When you want the screen to be easier to see, you can angle it forwards by altering the bracket attachment locations. (5°)

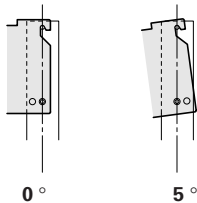

To safely attach the brackets to the support columns, be sure to always have two people set it in place using the pole as shown in the figure.

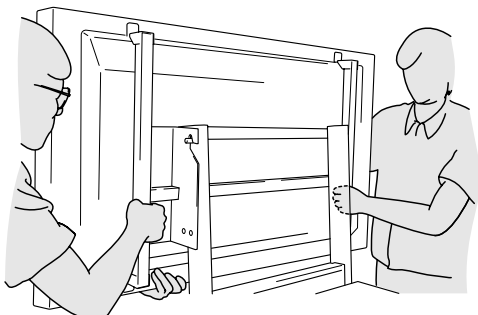

⑥ Attach the shelf board to the mounting hardware.

Using the providing ornament screws (M6 x 12), attach the shelf bracket to the stand shelf. Follow the same procedure to fix the shelf bracket on the other side to the stand shelf.

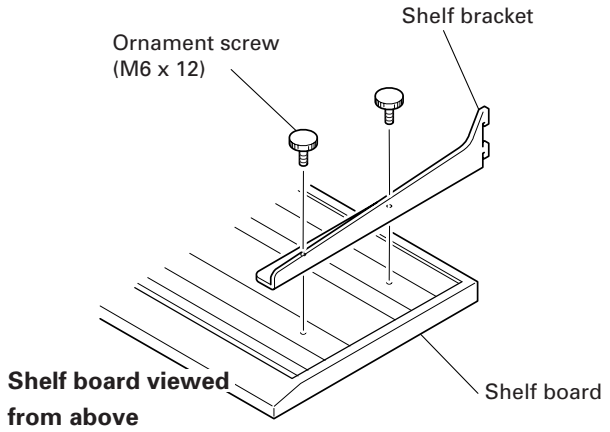

⑦ Mount the shelf board onto the panel support.

Tilt the shelf board, and insert the upper part of the hook into the panel support slits. Then return it to a level position.

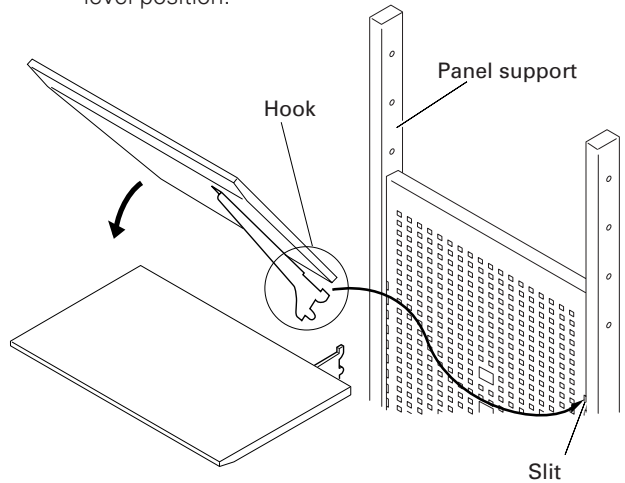

⑧ Adjusting the support caster.

When the mobile cart has been placed into position, be sure to adjust the support caster to fix into place.

1. Turn the support caster in the direction indicated by the arrow until the bottom of the caster touches the floor.
2. Turn the nut at the top of the caster in the direction indicated by the arrow to fix the caster into place.

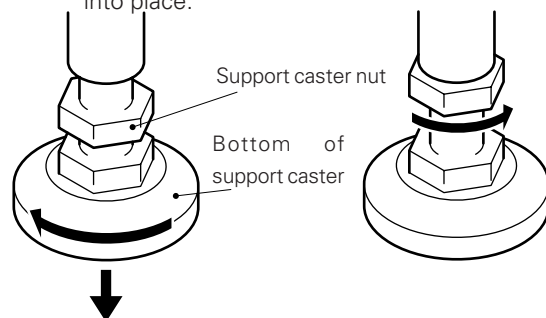

4.9 Speaker System: PDP-S03-LR

4.9.1 Specifications

External dimensions	74 (W) × 98 (D) × 714 (H) mm
	1368 (W) × 103 (D) × 714 (H) mm (with plasma display monitor PDP-502MX mounted)
Weight	2.7 kg (× 1)
	45.7 kg (with plasma display monitor PDP-502MX mounted)
Dimensions of packaging	818 (W) × 315 (D) × 171 (H) mm
Weight when packaged	7.6kg
Cabinet	Closed type, magnetic-shielded design (EIAJ)
Speaker (two way)	
Low and mid-range	
sounds (woofers)	2 elliptic cones
High (Tweeter)	2.5-cm dome
Nominal impedance	8 Ω
Playback frequency	50 to 60,000 Hz
Output sound pressure	84 dB/W (1m)
Permissible input	
Maximum output (EIAJ)	12 W
Rated input (EIAJ)	4 W
Crossover frequency	4 kHz
Accessories (for one set of speakers)	
.....	Speaker cord × 2 (5 m), Flat head screw × 4, Hexagonal socket head screw × 4, Hexagonal wrench × 1, Washer M8 (φ 25) × 4, Mounting hardware × 4, Mounting plate (L and R) × 1, Warranty card × 1, Operating instructions × 1

NOTE

When the speakers are mounted to the sides of the display, you will not be able to use the operation panel on the display.

4.9.2 External Dimensions (with plasma display monitor PDP-502MX mounted)

 : Center of gravity

(Unit: mm)

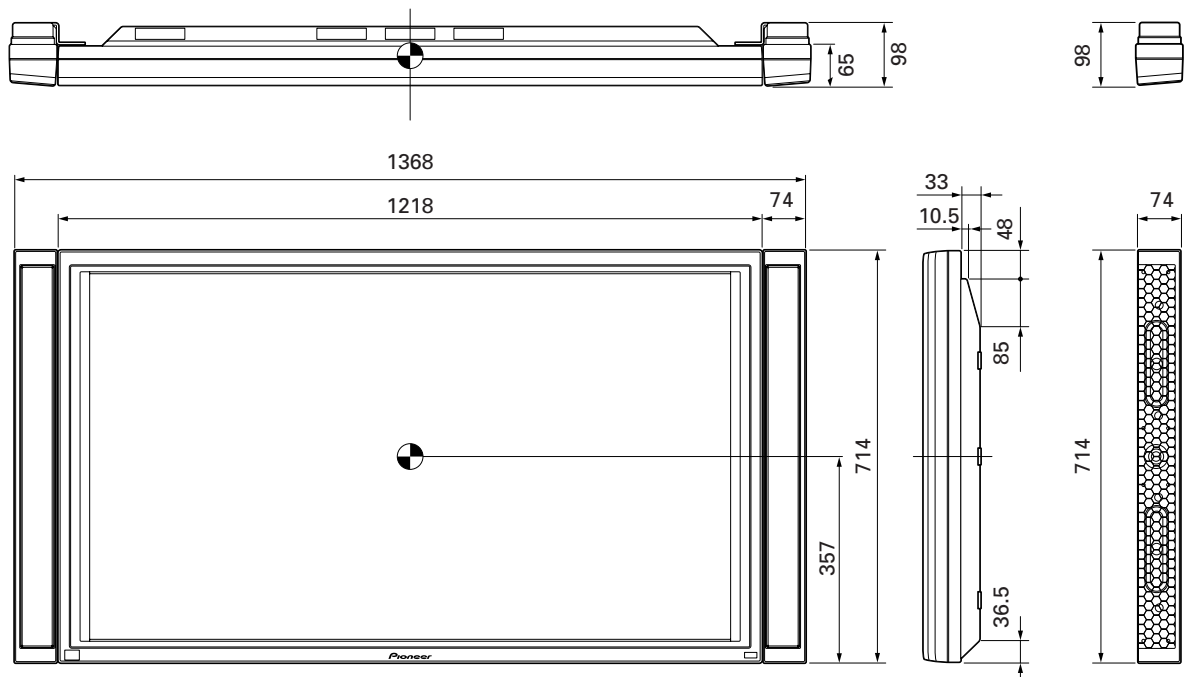

Speaker System

4.9.3 Mounting to the main unit

1) Installing procedure

Install the speaker according to the procedure (1) through (3) below: **The illustrations below show the speaker (for right) to be mounted to the right of the display.**

Caution:

When the speaker is mounted to the display, the operation panel of the display cannot be used. A remote controller supplied to the display should be used.

(1) Affixing the mounting plate to the speaker

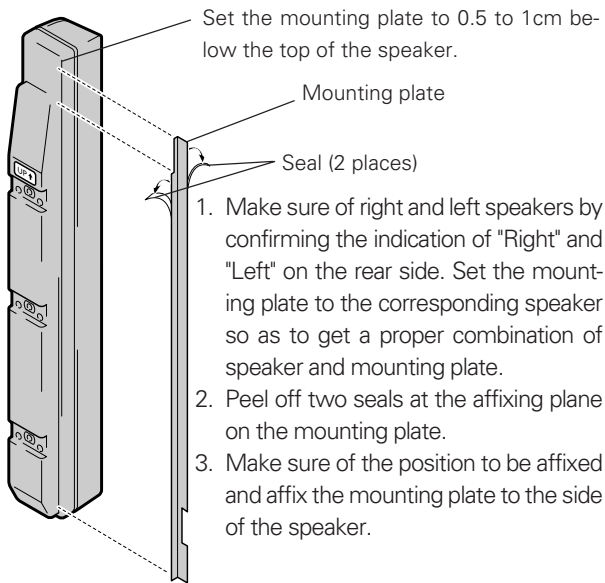

Note : Mounting plates should be attached to speakers only when speakers are attached to the display.

(2) Installing the metal fixture on the speaker

- Washers M8 (φ 25) are supplied for third-party metal fixtures.
- Mount commercial fixtures by the two-point mounting method to the mounting holes provided at the center or bottom of the back of the speaker. These mounting holes are at different levels. To make the hole levels even, use additional washers until they are flush.

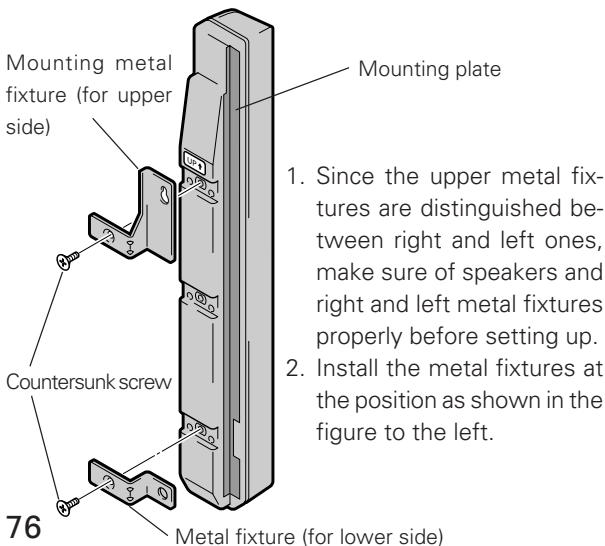

(3) Installing the speaker to the side of the plasma display

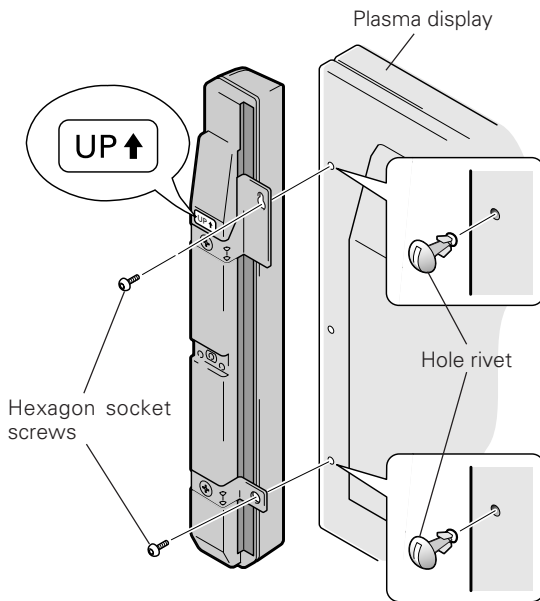

1. Remove the hole rivets (two places on a single side) from the rear of the display (by turning the hole rivet with a coin and so forth).
2. Make sure of right and left position by looking at the indication of "Right" and "Left" on the rear side of the speakers. With the "UP↑" indication placed upward, install the upper metal fixture first and then the lower one on the display.
(To make allowance for clearance correction, temporarily install the display.)
3. Adjust the position of the display so that the clearance between the speakers and the display is even, then fully tighten the screws.



Caution

- When you install the speakers, using screws other than those provided may cause the speakers to fall or malfunction. Use only the screws provided for installation.
- When the display is to be moved after installing the speakers, do not hold the speaker itself. Please move the display by holding its lower side.

2) Connection with a stereo amplifier

1. Turn off the power switch of a stereo amplifier.
2. Connect an input terminal of the speaker system with a speaker output terminal of the stereo amplifier using the supplied speaker cords. Polarity of the input terminal is positive (+) for red terminal (right terminal in the figure below) and negative (-) for black (left terminal in the figure below).

- ① Remove the wire covering and keep the end of each wire together.



- ② Press the respective lever down, insert the applicable wire into the hole and then release the lever.

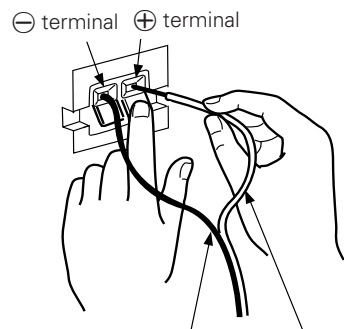

To ⊖ pole. To ⊕ pole.
(Speaker output terminal of the stereo amplifier)

- Make sure that the end of the cord is securely connected with the terminals by lightly pulling the cord after connection. Incomplete connection may cause broken sound or noise.
- If the cord wiring sticks out and the positive and negative wires short, the stereo amplifier will be subjected to an excessive load, and operation may stop or a malfunction may occur.
- When wrong polarity (+, -) of either speaker system (right or left) is connected to the stereo amplifier, proper stereo effects may not be obtained due to insufficient bass or loss of sound orientation feeling.

3) Installing procedure of commercially available metal fixture

Washers M8 (ϕ 25) are supplied to use together with commercially available metal fixtures.

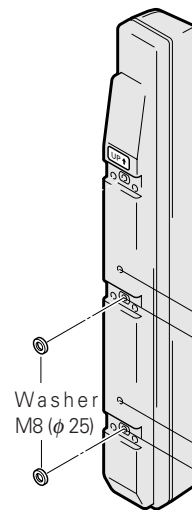

- Fix commercially available metal fixture at either position of mounting holes for commercially available metal fixture at the center or bottom of the rear side of the speakers with two bolts. Since there is a difference in step between these two mounting holes, the washer is used to diminish that difference.

Washer M8 (ϕ 25)
Fix the fixture by two bolts at either position. Use the washer for lower mounting hole to compensate the difference in step between two holes.

4) Cleaning the cabinet

- Lightly wipe off dust or dirt by a polishing cloth or a dry cloth.
- If the cabinet is very dirty, clean off the dirt using a soft cloth dipped in a neutral cleanser diluted 5 - 6 times, then wipe off any moisture using a dry cloth. Do not use a furniture wax or cleaner because it may dissolve or discolor the surface.
- Note that the surface may be dissolved or discolored when thinner, benzene, or spray type insecticide is stuck there.
- If using a chemically impregnated cloth, take care to observe the caution notices applying to use of the cloth.

Speaker System

4.9.4 Mounting with the plasma display ceiling suspension hardware (PDK-5002)

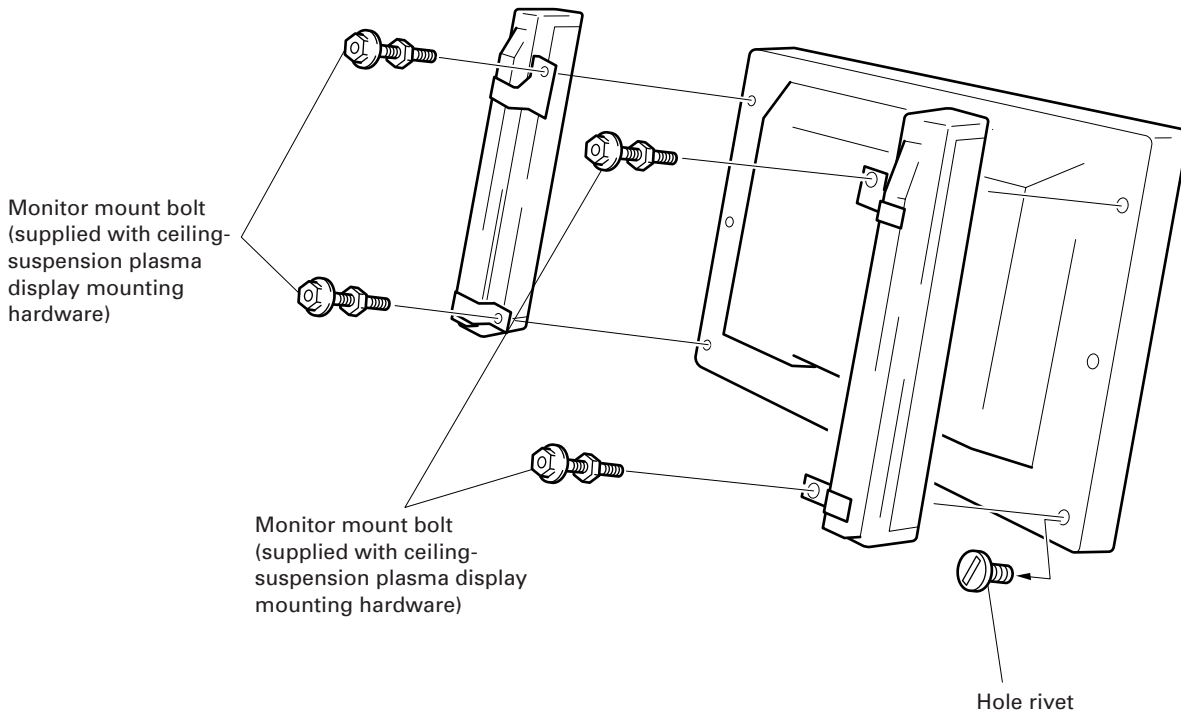

Figure 2

When mounting the plasma display, with the optional speakers attached, to the ceiling suspension hardware, first attach the speakers to the display with monitor mount bolts, as shown in **Figure 2**. Next, referring to **Figure 3**, monitor mount bolts to fasten the ceiling suspension hardware to the display, using the washers (ϕ 25 mm in outside diameter) supplied with the original speaker.

Follow the normal mounting procedure to attach the mounting hardware to the display.

Mounting the optional speakers to the display makes it difficult to see the monitor mount bolts. Take care while performing mounting work.

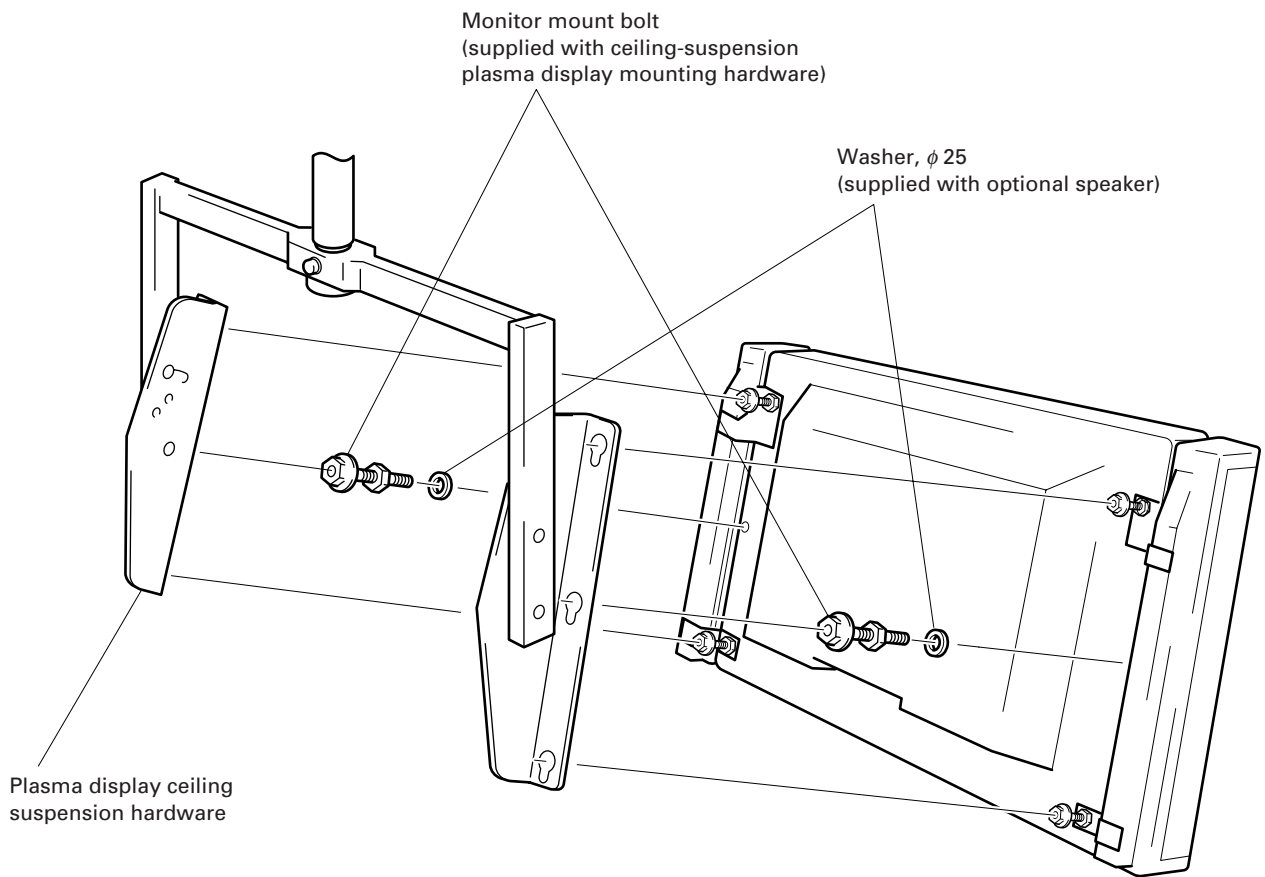
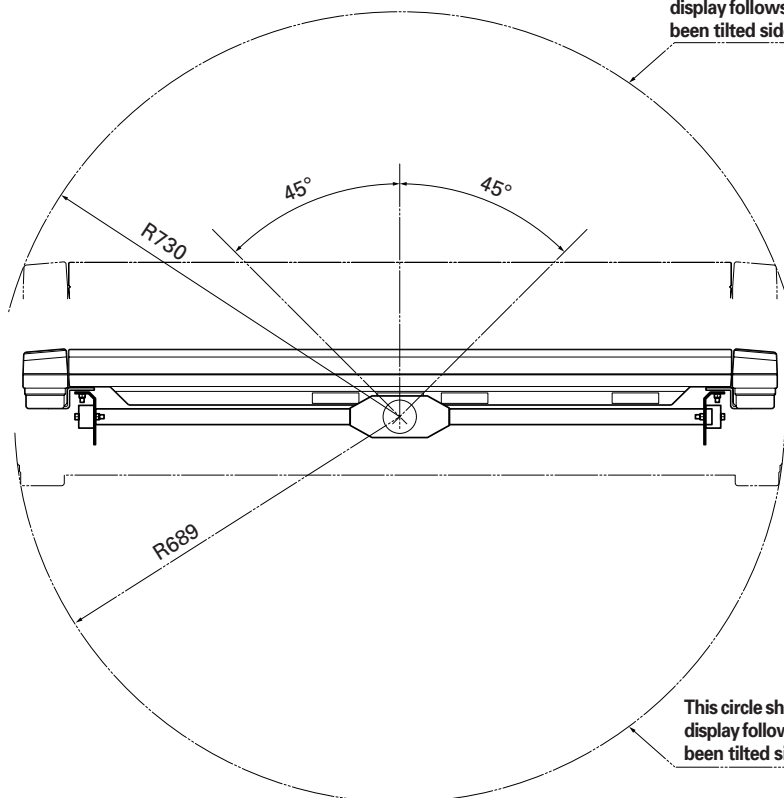

Figure 3

This circle shows the path that the outermost part of the plasma display follows when it is rotated about a vertical axis after having been tilted sideways by 25°.



Maximum sideways tilt: 45°

This circle shows the path that the outermost part of the plasma display follows when it is rotated about a vertical axis after having been tilted sideways by 25°.

Speaker System

4.9.5 Mounting with PDK-5006 (wall-mounting hardware)

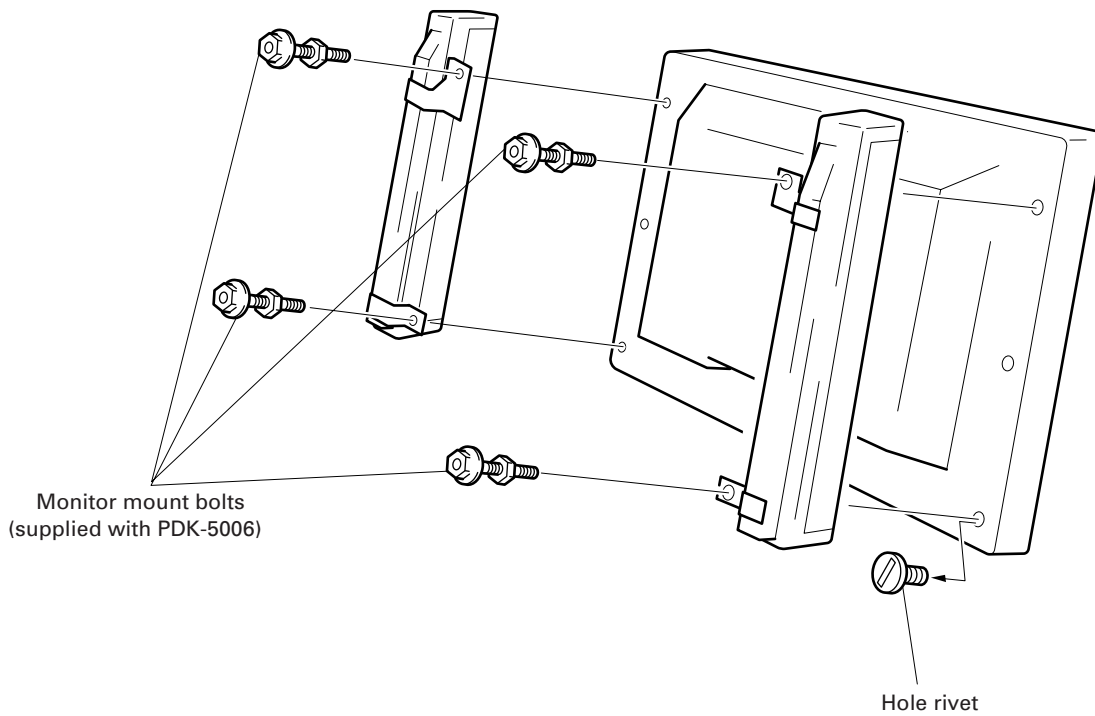

Figure 4

When mounting the plasma display, with the optional speakers attached, to the wall-mounting hardware, first fasten the speakers to the display with the supplied monitor mount bolts, as shown in **Figure 4**. Next, referring to **Figure 5**, follow normal mounting procedures to secure the mounting hardware to the display.

Mounting the optional speakers to the display makes it difficult to see the monitor mount bolts and angle-setting screws. Take care while performing mounting work.

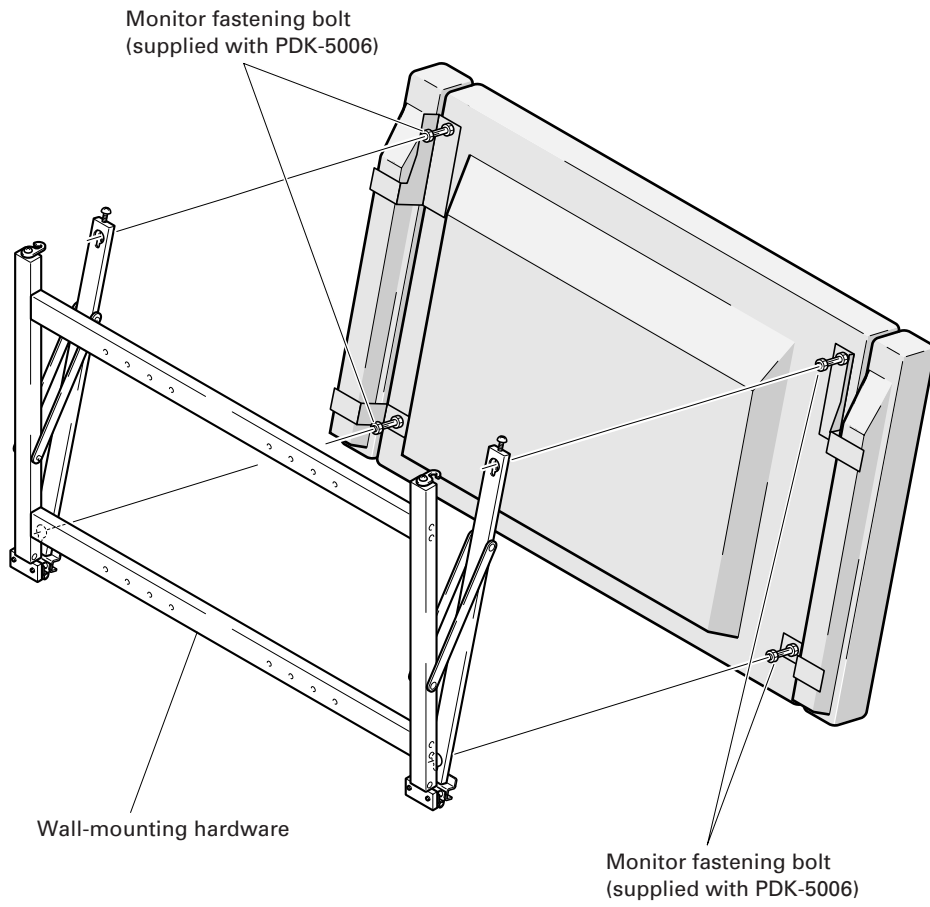

Figure 5

Before Beginning Adjustments

5.1 Before Beginning Adjustments

You can make adjustments to the unit in the following ways:

- With the operating panel of the main unit
- With the remote control unit
- With a PC (through RS-232C)

Make sure you've thoroughly read and understood the following before making any adjustments.

5.1.1 Operating mode

The system has the following four major operating modes:

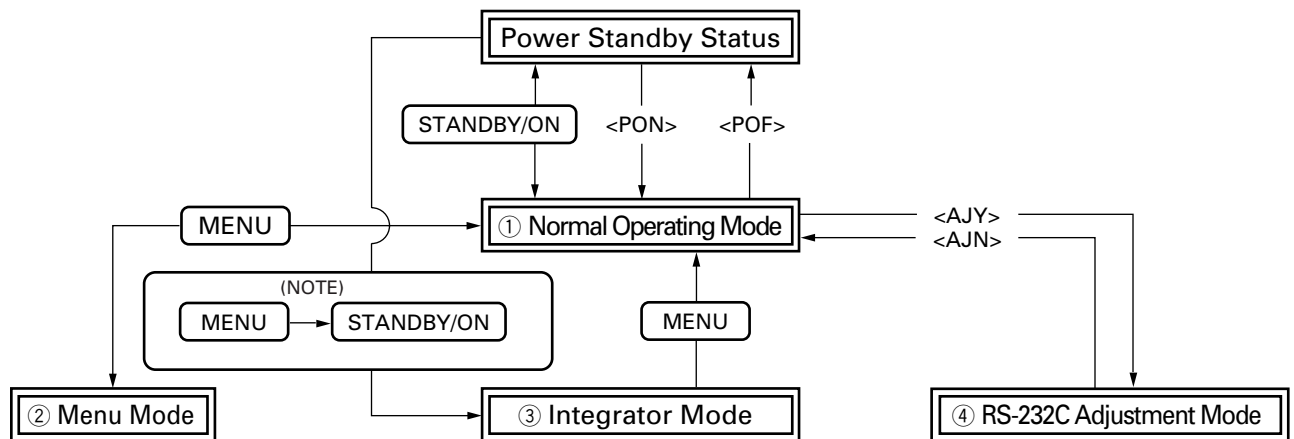

 indicates operating mode and status.

 indicates button operations on the remote control or on the operating panel of main unit .

< > indicates RS-232C command operations.

(NOTE) Refer to 5.4.1, "About the integrator mode".

① Normal Operating Mode

Intended for video playback, this mode enables the following basic operations:

Switching to STANDBY status (POWER OFF)

- Switching to power standby status
- Screen-size switching
- Volume adjustment/muting (remote control only)
- Moving to the various adjustment modes such as menu mode.

Additionally, normal operating mode also enables some of the RS-232C commands controls (as discussed in 5.5.4, "List of RS-232C commands").

② Menu Mode

This mode is for adjusting the resolution and the image position and for carrying out the various other settings. Refer to 5.3, "Menu Mode", for further details.

This mode allows you to change adjustment data within certain limits, based on values adjusted in Integrator or RS-232C adjustment modes (discussed later).

Refer to 5.3, "Menu Mode", for further details.

Before Beginning Adjustments

③ Integrator Mode

This mode provides adjustment functions for the integrator.

White balance adjustment and various other settings are available in addition to those in the Menu mode. Refer to 5.4, "Integrator Mode" for further details.

④ RS-232C Adjustment Mode

This mode enables various adjustments and settings using a PC.

Some adjustment items are available only in this mode.

CAUTION

When adjustment/setting has been made under this mode, enter ID first before other any other actions.

Refer to 5.5, "RS-232C Adjustment Mode", for further details.

5.1.2 Combination use of remote control unit, operating panel and PC

- The remote control and the operating panel of the main unit may be used together.

(Example) You can enter the Menu mode through the operating panel of the main unit, then make adjustments using the remote.

- Depending on which has transmitted the more recent command, either the remote, the operating panel of the main unit, or the RS-232C may originate the command currently in effect.

(Example) Operation

- ① Press the MENU button on the remote control
(or on the operating panel of the main unit).

→

Action
Enters Menu mode.

At this time, the only available RS-232C commands are:

- <AJY>
- <POF>

- ② Now, issue an <AJY> command from a PC.

→

Menu mode is disabled, and RS-232C adjustment mode is activated.

At this time, only the following options are available from the remote control (or the operating panel of the main unit):

- Power switch
- MENU button
- KEY LOCK/UNLOCK button

(NOTE) The remote does not have a KEY LOCK/UNLOCK button.

5.1.3 Lists of supported input signals

1) Input Video Signals Supported

INPUT 1

	Signal Format	Screen size					Remark
		4 : 3 NORMAL	FULL	ZOOM	CINEMA WIDE	NATURAL WIDE	
NTSC	Composite	○	○	○	○	○	
PAL	Composite	○	○	○	○	○	
SECAM	Composite	○	○	○	○	○	
4.43 NTSC	Composite	○	○	○	○	○	

INPUT 2

	Signal Format	Screen size					Remark
		4 : 3 NORMAL	FULL	ZOOM	CINEMA WIDE	NATURAL WIDE	
NTSC	S-Video (Y/C)	○	○	○	○	○	
PAL	S-Video (Y/C)	○	○	○	○	○	
SECAM	S-Video (Y/C)	○	○	○	○	○	
4.43 NTSC	S-Video (Y/C)	○	○	○	○	○	

INPUTS 3 and 4

Vertical Frequency Fv (Hz)	Horizontal Frequency Fh (kHz)	Signal Format	Screen size					Remark
			4 : 3 NORMAL	FULL	ZOOM	CINEMA WIDE	NATURAL WIDE	
50	15.625	Component	○	○	○	○	○	
		RGB	○	○	○	○	○	
60	15.734	Component	○	○	○	○	○	480i (SDTV)
		RGB	○	○	○	○	○	
	31.5	Component	○	○	○	○	○	480p (SDTV)
		RGB	○	○	○	○	○	
	33.75	Component	---	○	---	---	---	1080i (HDTV)
		RGB	---	○	---	---	---	
45.0	Component	---	○	---	---	---	720p (HDTV)	
	RGB	---	○	---	---	---		
67.5	Component	---	○	---	---	---	1080p (HDTV)	
	RGB	---	○	---	---	---		

Before Beginning Adjustments

2) Input PC Signals Supported

□ Table of PC Signal Responses

Resolution (Dot x Line)	Vertical Frequency	Horizontal Frequency	Screen Size (Dot x Line)				Remark
			ORIGINAL	4:3NORMAL	FULL	ZOOM	
640 x 400	56.4Hz	24.8kHz			○ 1280 x 768		NEC PC-9800
	70.1Hz	31.5kHz			↑		NEC PC-9800
640 x 480	60Hz	31.5kHz	◎ 640 x 480	○ 1024 x 768	○ 1280 x 768		(852 x 480) (864 x 480)
	66.7Hz	35.0kHz	↑	↑	↑		Apple Macintosh 13"
	72Hz	37.9kHz	↑	↑	↑		
	75Hz	37.5kHz	↑	↑	↑		
800 x 600	85Hz	43.3kHz	↑	↑	↑		
	56Hz	35.2kHz	◎ 800 x 600	○ 1024 x 768	○ 1280 x 768		
	60Hz	37.9kHz	↑	↑	↑		(1072 x 600)
	72Hz	48.1kHz	↑	↑	↑		
832 x 624	75Hz	46.9kHz	↑	↑	↑		
	85Hz	53.7kHz	◎ 800 x 600	○ 1024 x 720	○ 1280 x 720		
832 x 624	74.6Hz	49.7kHz	◎ 832 x 624	○ 1024 x 748	○ 1280 x 748		Apple Macintosh 16"
1024 x 768	43Hz Interlace	35.5kHz	△ 1024 x 768		△ 1280 x 768		
	60Hz	48.4kHz	◎ 1024 x 768		○ 1280 x 768		(1376 x 768)
	70Hz	56.5kHz	↑		↑		
	75Hz (74.9Hz)	60.0kHz (60.2kHz)	↑		↑		Figures in brackets are for Apple Macintosh 19"
1152 x 864	85Hz	68.7kHz	↑		↑		
	60Hz	53.7kHz		△ 1024 x 768	△ 1280 x 768		
	72Hz	64.9kHz		↑	↑		
1152 x 870	75Hz	67.7kHz		↑	↑		
	75.1Hz	68.7kHz		△ 1024 x 768	△ 1280 x 768		Apple Macintosh 21"
1152 x 900	66.0Hz	61.8kHz		△ 1024 x 768	△ 1280 x 768		Sun Microsystems LO
	76.0Hz	71.7kHz		↑	↑		Sun Microsystems HI
1280 x 768	56Hz	45.1kHz	◎ 1280 x 768				
1280 x 960	60Hz	60.0kHz		△ 1024 x 768	△ 1280 x 768		
1280 x 1024	43Hz Interlace	46.4kHz			△ 1280 x 768		
	60Hz	64.0kHz		△ 960 x 768	△ 1280 x 768	◎ 1280 x 768	
	75Hz	80.0kHz		△ 960 x 768			(1600 x 1024)
	85Hz	91.1kHz		↑			
1600 x 1200	60Hz	75.0kHz		△ 1024 x 768			
	65Hz	81.3kHz		↑			
	70Hz	87.5kHz		↑			

Shaded boxes correspond to screen sizes that cannot be selected.

Key:

◎ The best video image can be obtained. SCREEN (position, frequency, phase) may have to be adjusted.

○ If screen is enlarged, fine details may become difficult to view.

△ Simple indication. Fine details may be decreased.

Screen size is indicated with ~(TYPE).

3) About Screen Size

① Screen sizes for video signal input

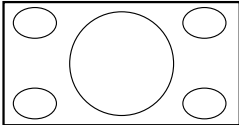
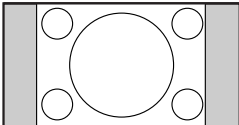
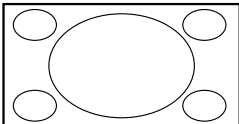
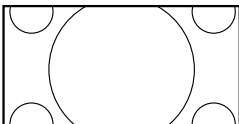
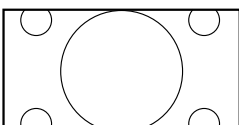
Appearance of picture	
NATURAL WIDE 	Suitable for watching news and sports etc. With movies and sports etc., gives a spacious impression with plenty of punch.
4 : 3 NORMAL 	Suitable for watching news and dramas etc. Can watch programs with the original image soft (software) picture border. (In order to prevent the screen from burning out, the picture border will be displayed in a slightly different position every time you turn the display on.)
FULL 	Suitable for high vision pictures and wide-screen pictures ("squeeze") Of the movie theater size pictures, predominantly suitable for CinemaScope size pictures. Gives a really spacious impression with even more punch.
ZOOM 	Of the movie theater size pictures, predominantly suitable for Vista size pictures. Gives a really spacious impression with even more punch.
CINEMA WIDE 	This screen size is convenient when you are watching CinemaScope size pictures with "Jimaku Super" subtitles.

② Screen sizes for PC signal input

- ORIGINAL

Faithful 1:1 reproduction of the dots and lines of the input signal on the screen.

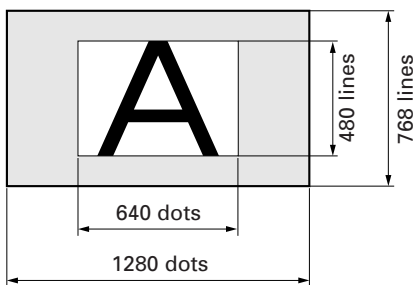

(This diagram is for 640 x 480 input)

- 4:3 NORMAL

Reproduction that fills the screen without changing the aspect ratio of the input signal.

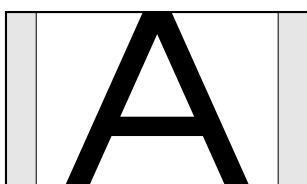

- FULL

16:9 reproduction of the input signal that really fills the screen.

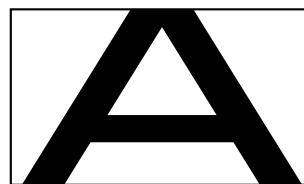

- ZOOM

ZOOM is possible with 1280 x 1024 / 60Hz input signals only. Faithful 1:1 reproduction of the dots and lines of the input signal on the screen. Note however that only part of the picture is displayed (part is lost off the edges of the screen).

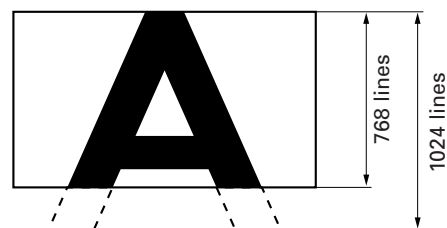

Use the ▲/▼ buttons to adjust the image position (V-scroll function).

Before Beginning Adjustments

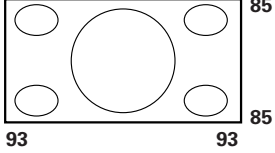
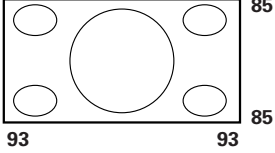
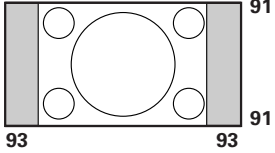
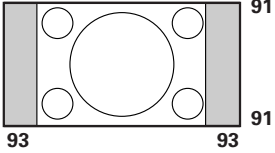
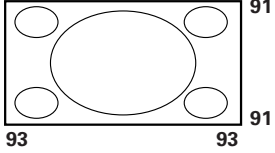
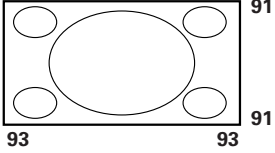
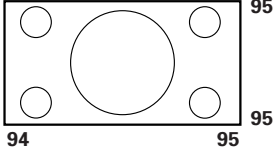
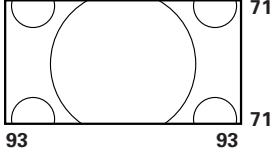
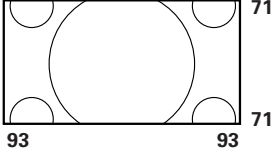
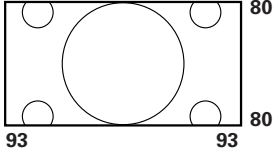
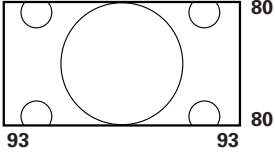
Supplementary instructions	Amount of screen information with video input signals (default settings)		
	NTSC (60Hz system)	PAL (50Hz system)	HDTV system
NATURAL WIDE			
4:3 NORMAL			
FULL			
ZOOM			
CINEMA WIDE			

Units: %

5.1.4 List of adjustable and settable items

1) Normal Operating Mode

- V. POSITION (V scroll function)

When the screen size is set to CINEMA WIDE or ZOOM, you can adjust the image position using the 5/5 buttons

	Screen size	Variable range
Video signal input	ZOOM	±25
	CINEMA WIDE	±15
PC signal input (Adjustment possible only for 1280 × 1024/ 60Hz)	ZOOM	±64

2) Menu Mode

	Variable Range (STEP)	One-Step Increment (/STEP)	INPUT 1	INPUT 2	INPUT 3			INPUT 4		
			Video Signal	Video Signal	Video Signal		PC Signal	Video Signal		PC Signal
			Composite	S-Video (Y/C)	Component	RGB	RGB	Component	RGB	RGB
CONTRAST	± 32	× 3	○	○	○	○	○	○	○	○
BRIGHT	± 32	× 3	○	○	○	○	○	○	○	○
COLOR	± 16	× 2	○	○	○	○		○	○	
TINT	± 16	× 2	○	○	○	○		○	○	
SHARP	± 32	× 2	○	○	○	○		○	○	
R LEVEL	± 32	× 3					○			○
G LEVEL	± 32	× 3					○			○
B LEVEL	± 32	× 3					○			○
H.POSITION	± 64	(NOTE 2)			○	○	○	○	○	○
V.POSITION	± 64	(NOTE 2)	(NOTE 1) ①	(NOTE 1) ①	○	○	○	○	○	○
V.SIZE	± 32	× 1			○	○		○	○	
CLK FREQUENCY	± 64	× 1					○			○
CLK PHASE	± 8	× 1					○			○
POWER SAVE (VIDEO)	MODE 1/OFF		○ (NOTE 3)					○ (NOTE 3)		
POWER SAVE (PC)	MODE 1/MODE 2/OFF						○ (NOTE 4)			○ (NOTE 4)
COLOR SYSTEM	AUTO/NTSC PAL/SECAM 4.43 NTSC		○	○						
3D Y/C MODE	STILL/MOTION		○ (NOTE 6)							
HIGH CONTRAST	ON/OFF		○ (NOTE 3)					○ (NOTE 3)		
SETTING	VIDEO/PC				△ (NOTE 5)			△ (NOTE 5)		
SIGNAL	RGB COMPONENT 1 COMPONENT 2				○			○		
CLAMP	MODE 1/MODE 2						○			○
ABL	ON/OFF						○			
H. ENHANCE	± 32	-					○			○
V. ENHANCE	± 32	-					○			○

(NOTE 1) In the cases described below, V.POSITION adjustment cannot be performed. In Normal Operating mode, V.SCROLL would be used. The cases in which V.SCROLL can be used are when:

- ① (INPUT 1 or 2 has been selected) using screen size ZOOM or CINEMA WIDE;
- ② (video signal input) using screen size ZOOM or CINEMA WIDE;
- ③ (1280 × 1024/60 Hz input) using screen size ZOOM.

(NOTE 2) The one-step increment may vary, depending on input signal and screen size. The range of adjustment values is also bounded (a limiter is inserted).

(NOTE 3) All functions have the same setting(when video signals are input).

(NOTE 4) INPUT 3 and INPUT 4 have the same setting (when PC signals are input).

(NOTE 5) Only need be set with signal input of vertical frequency 60Hz and horizontal frequency 31.5kHz (for signals of other frequencies is set automatically)

(NOTE 6) Setting of the '3D Y/C MODE' is only possible when both of the following conditions are satisfied:

- INPUT 1 has been selected.
 - The COLOR SYSTEM is set to AUTO and NTSC signals are being inputted
- OR
- The COLOR SYSTEM is set to NTSC

With items that have the mark, RESET or ALL RESET will reset to the default value.

Before Beginning Adjustments

3) Integrator Mode

	Variable Range (STEP)	INPUT 1	INPUT 2	INPUT 3			INPUT 4			
		Video Signal	Video Signal	Video Signal		PC Signal	Video Signal		PC Signal	
		Composite	S-Video (Y/C)	Component	RGB	RGB	Component	RGB	RGB	
CONTRAST	0 to (128) to 255	○	○	○	○	○	○	○	○	↕
BRIGHT	0 to (128) to 255	○	○	○	○	○	○	○	○	↕
COLOR	0 to (32) to 63	○	○	○	○		○	○		↕
TINT	0 to (32) to 63	○	○	○	○		○	○		↕
H. SHARP	0 to (128) to 255	○	○	○	○		○	○		↕
V. SHARP	0 to (128) to 255	○	○	○	○		○	○		↕
R HIGH	0 to (128) to 255	○	○	○	○	○	○	○	○	↕
G HIGH	0 to (128) to 255	○	○	○	○	○	○	○	○	↕
B HIGH	0 to (128) to 255	○	○	○	○	○	○	○	○	↕
R LOW	0 to (128) to 255	○	○	○	○	○	○	○	○	↕
G LOW	0 to (128) to 255	○	○	○	○	○	○	○	○	↕
B LOW	0 to (128) to 255	○	○	○	○	○	○	○	○	↕
H. POSITION	0 to (128) to 255	○	○	○	○	○	○	○	○	↕
V. POSITION	0 to (128) to 255	○	○	○	○	○	○	○	○	↕
V. SIZE	64 to (128) to 191	○	○	○	○		○	○		↕
CLK FREQUENCY	64 to (128) to 191					○			○	↕
CLK PHASE	0 to (8) to 16					○			○	↕
SIDE MASK R	0 to 255	○ (NOTE 1)								
SIDE MASK G	0 to 255	○ (NOTE 1)								
SIDE MASK B	0 to 255	○ (NOTE 1)								
SUB VOLUME IN 1	0 to 63	○								↕ (NOTE 4)
SUB VOLUME IN 2	0 to 63		○							↕ (NOTE 4)
SUB VOLUME IN 3	0 to 63				○					↕ (NOTE 4)
SUB VOLUME IN 4	0 to 63							○		↕ (NOTE 4)
COLOR MODE	1/2	○ (NOTE 1)								
MIRROR MODE	XY/XY/OFF	○ (NOTE 1)								
BRIGHT ENHANCE (VIDEO)	ON/OFF	○ (NOTE 2)					○ (NOTE 2)			
BRIGHT ENHANCE (PC)	ON/OFF					○ (NOTE 3)			○ (NOTE 3)	
OSD	ON/OFF	○ (NOTE 1)								
BAUD RATE	1200 to 19200BPS	○ (NOTE 1)								
FULL MASK	OFF/ON/RED/ GREEN/BLUE	○ (NOTE 1)								
FAN CONTROL	AUTO/FIXED(MAX)	○ (NOTE 1)								

(NOTE 1) All functions have the same setting.

(NOTE 2) All functions have the same setting (when video signals are input).

(NOTE 3) INPUT 3 and INPUT 4 have the same setting (when PC signals are input).

With items that have the  mark, DEFAULT or ALL DEFAULT will reset to the default value.
(NOTE 4) The SUB VOLUME can only be set to the DEFAULT value.

5.1.5 Last Memory

The last memory timing used by the unit is given in the table below.

Remember, no last memory function is executed if you perform the following without meeting these timing requirements:

- Switch off MAIN POWER;
- Unplug the power;
- Switch off the outlet.

Item	Memory Timing
Operation in Normal Operating Mode <ul style="list-style-type: none"> • Power switch On/Off • Input switchover • Changing of screen size • Volume adjustment/muting • Setting of KEY LOCK/UNLOCK 	<ul style="list-style-type: none"> • Approximately four seconds after the end of the operation • When entering the STANDBY status through remote operation, through the operating panel of the main unit, or by issuing a <POF> command. • When switched to Menu mode as a result of a MENU button action • When switched to RS-232C adjustment mode by an <AJY> command (NOTE) Among the RS-232C commands available in Normal Operating mode, some are not stored in last memory when used in this mode. See 5.5.1, "About the RS-232C Adjustment Mode".
Adjustments and settings in menu mode	<ul style="list-style-type: none"> • Approximately four seconds after the end of the operation • When entering the STANDBY status through remote operation, through the operating panel of the main unit, or by issuing a <POF> command • When returning to the previous screen with the SET button • When exiting Menu mode with the MENU button (restoring the unit to Normal Operating mode) • When exiting Menu mode with the KEY LOCK/UNLOCK button (switching unit to Normal Operating mode and entering the KEY LOCK status) • When switching to RS-232C adjustment mode with an <AJY> command • When switching over to another input signal mode (i.e., to another signal frequency) (restoring the unit to Normal Operating mode) • When automatically exiting Menu mode after persistence of no-signal status for approximately eight minutes (restoring the unit to Normal operating mode)
Adjustments and settings in Integrator mode	<ul style="list-style-type: none"> • Approximately four seconds after the end of the operation • When entering the STANDBY status through remote operation, through the operating panel of the main unit, or by issuing a <POF> command • When returning to the previous screen with the SET button • When exiting Integrator mode with the MENU button (restoring the unit to Normal Operating mode) • When exiting Integrator mode with the KEY LOCK/UNLOCK button (switching unit to Normal Operating mode and entering the KEY LOCK status) • When switching to RS-232C adjustment mode with an <AJY> command • When switching over to another input signal (i.e., to another signal frequency) (restoring the unit to Normal Operating mode) • When automatically exiting Integrator mode after persistence of no-signal status for approximately three minutes (restoring the unit to Normal operating mode)
Adjustments and settings in RS-232C adjustment mode	<ul style="list-style-type: none"> • Approximately four seconds after the end of the operation • When entering the STANDBY status through remote operation, through the operating panel of the main unit, or by issuing a <POF> command • When changing adjustment or setting items using PC commands • When exiting the RS-232C adjustment mode with an <AJY> command (restoring the unit to Normal Operating mode) • When exiting RS-232C adjustment mode with the KEY LOCK/UNLOCK button (switching unit to Normal Operating mode and entering the KEY LOCK or KEY/UNLOCK status) • When switching to the Menu mode with the MENU button

(NOTE) If you start or stop the entire system by switching a breaker on or off, allow enough time for the last memory function to be performed by satisfying the timing requirements given above.

Note that this practice causes count errors on the hour meter.

5.1.6 Aging

After switching on power to the unit, input signals to perform aging until the unit stabilizes. Use signals that are unlikely to cause the displayed images to be "burned" onto the screen: signals such as a 100 % white signal, or animation from LDs are recommended. The process should take about 30 minutes. This ensures precision adjustments.

(NOTE) Display of still images over extended periods can lead to the above-mentioned "burning".

Before Beginning Adjustments

5.2 Normal Operating Mode

5.2.1 About normal operating mode

Normal operating mode enables the following:

① Input switching

- Pressing one of the INPUT buttons, 1 to 4 → Input switches over to the selected input.
- Pressing the INPUT button on the operating panel of the main unit → This switches the input to the next input.

② Screen-size switching

- Repeated pressing the (SCREEN) SIZE button on the remote control or the operating panel of the main unit changes screen size in the following sequence:

At INPUT 1 or 2, or when reproducing video signals via INPUT 3 or 4

→ NATURAL WIDE → 4 : 3 NORMAL → FULL → ZOOM → CINEMA WIDE →

When reproducing PC signals via INPUT 3 or 4

→ ORIGINAL → 4 : 3 NORMAL → FULL → ZOOM →

(NOTES) • The screen size at which playback can be performed differs according to the input signal.

See 5.1.3, "List of supported input signals".

Displays with "(TYPE)" appended, such as FULL (TYPE), will sometimes appear, indicating a simplified reproduction.

- In INPUT 2, if an S1 video signal is detected, the screen size will automatically switch to FULL. If S2 is detected, the screen size will switch to ZOOM.
- If an HDTV signal is detected, the screen size will switch to FULL (fixed).
- During video playback, switching screen size to ZOOM or CINEMA WIDE permits scrolling the screen up or down with the ▲ and ▼ buttons (V-SCROLL function). Refer to section 5.1.4, "List of adjustable and settable items".

You will note that the act of reduction, enlargement, etc. of the screen using the screen size changing function of this machine at a coffee shop, hotel, etc. for profit or for public view may result in infringement of the right of an author protected under the Copyright Law.

③ Display call

- Press the DISPLAY button on the remote control.
 - The current input function, the incoming signal's horizontal and vertical frequencies, current screen size, and other characteristics are displayed on the screen.

(NOTE) The displayed horizontal and vertical frequencies are measured values, and there may be some error in the measurements.

④ Volume adjustment/Muting

- Push the VOL + button on the remote control. → The volume increases.
- Push the VOL – button on the remote control. → The volume decreases.
- Push the MUTING button on the remote control. → Each time the button is pushed, it switches from MUTING ON to MUTING OFF, or vice versa.

⑤ In addition to the above, several RS-232C commands are also available.

Refer to section 5.5, "RS-232C Adjustment Mode".

Menu Mode

5.3 Menu Mode

5.3.1 About menu mode

1) How to enter/exit menu mode

- To enter menu mode and display the menu screen (refer to section 5.3.2, "Example of menu mode operation"), press the MENU button on the remote, or on the operating panel of the main unit while in normal operating mode. To return to normal operating mode, press the MENU button again.

2) When you carry out adjustments using menu mode:

- Each of the adjustment values for PICTURE and SCREEN will be stored separately for each input function and each input signal. For more details please refer to "5.4.5 PICTURE and WHITE BALANCE adjustment values memory area table" and "5.4.6 SCREEN adjustment values area table".

3) Notes

(1) You cannot change the input while in menu mode.

Select the input for the adjustment or setting you intend to perform before entering menu mode.

(2) Menu mode is canceled automatically and normal operating mode is restored in the following cases:

- When switching over to another input signal frequency
- When no control is operated for a period of approximately eight minutes
- When the KEY LOCK/UNLOCK button on the operating panel of the main unit is pressed

(3) For adjustments in the menu mode, refer to the operating manual.

(4) When making adjustments, we recommend using video signals that you actually intend to use.

5.3.2 Example of menu mode operation

Adjusting contrast is shown below as an example of basic operation in menu mode.

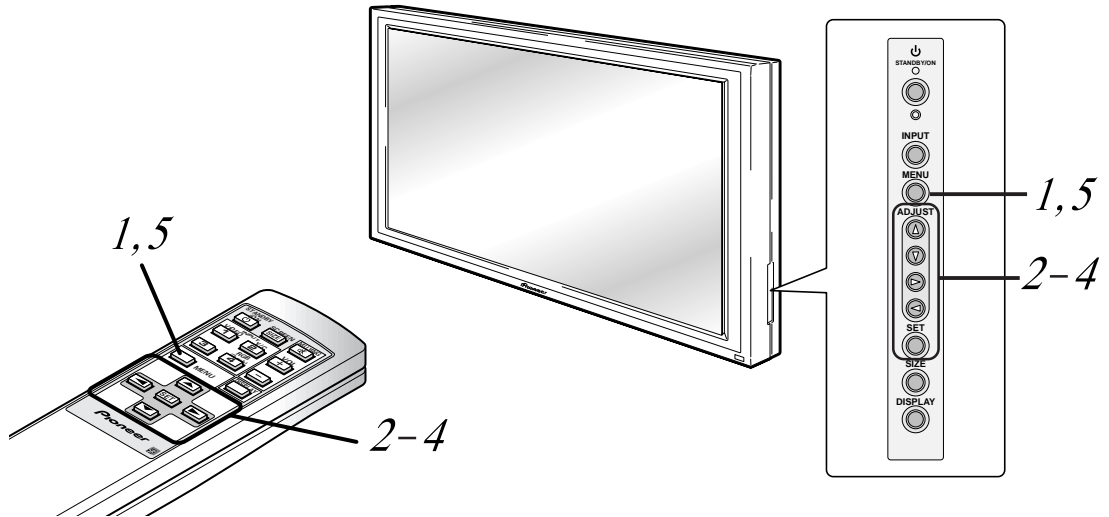

Step 1 Switch the display on the menu screen (activating menu mode).

Remote control unit



Main unit



MAIN MENU	
▶ PICTURE	CONTRAST : 0
SCREEN	BRIGHT : 0
ALL RESET	COLOR : 0
POWER SAVE	TINT : 0
SET UP	SHARP : 0
	RESET
MENU : MENU OFF	
▲▼▶ : SELECT	

The currently selected item is highlighted in heliotrope.

Step 2 Select PICTURE.

Remote control unit



Main unit

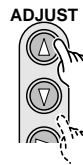

MAIN MENU	
▶ PICTURE	CONTRAST : 0
SCREEN	BRIGHT : 0
ALL RESET	COLOR : 0
POWER SAVE	TINT : 0
SET UP	SHARP : 0
	RESET
MENU : MENU OFF	
▲▼▶ : SELECT	

The currently selected item is highlighted in heliotrope.

Menu Mode

Step 3 Select CONTRAST.

3

Remote control unit



Main unit



MAIN MENU	
PICTURE	▶ CONTRAST : 0
SCREEN	BRIGHT : 0
ALL RESET	COLOR : 0
POWER SAVE	TINT : 0
SET UP	SHARP : 0
	RESET
MENU : MENU OFF	
▲▼ ◀ ▶ : SELECT SET : ADJUST	

Step 4 Make adjustments.

4

Remote control unit



Main unit

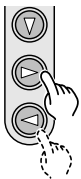

PICTURE	
CONTRAST	0 ██████████
◀▶ : ADJUST	SET : EXIT

Press the SET button to return to the screen in step 3.
To make other adjustments, repeat steps 3 to 4.

Step 5 Complete the procedure.

5

Remote control unit



Main unit



Restores normal operating mode.

5.3.3 Settings in menu mode

1) Setting power save

This is a function that automatically switches to a power-saving mode when a picture signal (sync signal) is not detected.

When input signals consist of PC signals, it is also possible to specify that an automatic reset be performed upon the re-input of video signals.

Set to OFF when using power save mode. → Set OFF

Go into power standby mode when no input signal is detected over a period of 8 minutes or more.

→ Set MODE 1

Switch between normal operating mode and power save mode depending on the presence or absence of input signals.

→ Set MODE 2

MODE 2 can only be set for PC signal.

Factory preset:	VIDEO : OFF
	PC : OFF

① Select POWER SAVE.

② Bring the cursor to VIDEO (or PC), change the setting with the SET button.

When the SET button is pushed:

VIDEO selected: OFF ↔ MODE

PC selected: OFF → MODE 1 →

MODE 2 → ...

Screen ①

MAIN MENU PICTURE SCREEN ALL RESET ▶POWER SAVE SET UP
MENU : MENU OFF ▲▼ : SELECT SET : NEXT

Screen ②

POWER SAVE ▶VIDEO : MODE 1 PC : MODE 2
EXIT ▲▼ : SELECT SET : CHANGE

(NOTE) MODE 1: Press the STANDBY/ON button on the remote control unit or the main unit operation panel in order to change from standby mode to normal operating mode

MODE 2: Operate the PC connected to the display or press the INPUT button on the remote control unit or the main unit operation panel in order to return from power-saving mode to normal operating mode

MODE 1: The power consumption in standby mode is 0.6W

MODE 2: The power consumption in power-saving mode is about 160W.

Menu Mode

2) Setting the color system

INPUT 1 and 2 support all the various formats used in worldwide, which they distinguish between automatically.

CAUTION

This unit is not compatible with PAL-M or PAL-N.

Normally, COLOR SYSTEM:AUTO is set for distinguishing automatically, but occasionally there may be instances of faulty playback, "no color", etc., as in cases of VTR signals from multifold-generated copy of VTR signals. In such a case, set as follows, according to the input signal.

Carry out the setting for either INPUT 1 or 2.

- For NTSC signal input → set COLOR SYSTEM : NTSC.
- For PAL signal input → set COLOR SYSTEM : PAL.
- For SECAM signal input → set COLOR SYSTEM : SECAM
- For 4.43 NTSC signal input → set COLOR SYSTEM : 4.43 NTSC

If you know what the previously input signal was, a fixed setting can be used for smooth signal handling; this can shorten signal-switching time and prevent errors in distinguishing signals.

Set-able condition: INPUT 1 or 2
Factory preset: INPUT 1 : AUTO
INPUT 2 : AUTO

① Select SET UP.

② Move the cursor to COLOR SYSTEM, and press the SET button to change the setting. Pressing the SET button moves the settings through the sequence AUTO→NTSC→PAL→SECAM→4.43 NTSC→...

Screen ①

```
MAIN MENU
PICTURE
SCREEN
ALL RESET
POWER SAVE
▶SET UP

MENU : MENU OFF
▲▼ : SELECT SET : NEXT
```

Screen ②

```
SET UP
▶COLOR SYSTEM : AUTO
3D Y/C MODE : MOTION
HIGH CONTRAST : OFF

EXIT
▲▼ : SELECT SET : CHANGE
```

3) Setting the three-dimensional Y/C separator

A three-dimensional Y/C separator is built into the INPUT 1 video input circuitry.

When you wish to show a still picture on the display screen, please set the "3D Y/C MODE to STILL".

Set-able condition : INPUT 1
Factory preset : MOTION

① Select SETUP.

② Move the cursor to 3D Y/C MODE and press the SET button to change the setting.
The SET button toggles 3D Y/C MODE between MOTION and STILL.

Screen ①

```
MAIN MENU
PICTURE
SCREEN
ALL RESET
POWER SAVE
▶SET UP

MENU : MENU OFF
▲▼ : SELECT SET : NEXT
```

Screen ②

```
SET UP
COLOR SYSTEM : AUTO
▶3D Y/C MODE : MOTION
HIGH CONTRAST : OFF

EXIT
▲▼ : SELECT SET : CHANGE
```

Menu Mode

4) Setting HIGH CONTRAST

This is a function that, for video signal input, adjusts the brightness of the parts of the picture with intermediate brightness, thus emphasizing the brightness.

You should set HIGH CONTRAST to ON when playing software with many dark scenes or when using the unit in a bright environment.

When you wish to accurately reproduce fine details (for example the texture of human skin), you should set HIGH CONTRAST to OFF.

Differences in the reproduced picture for HIGH CONTRAST ON and OFF (refer to diagram on right)

- OFF The brightness of the input signal is reproduced linearly
- ON The brightness of parts of the input signal with intermediate brightness is adjusted during reproduction

Set-able condition : Video signal input
 Factory preset : OFF

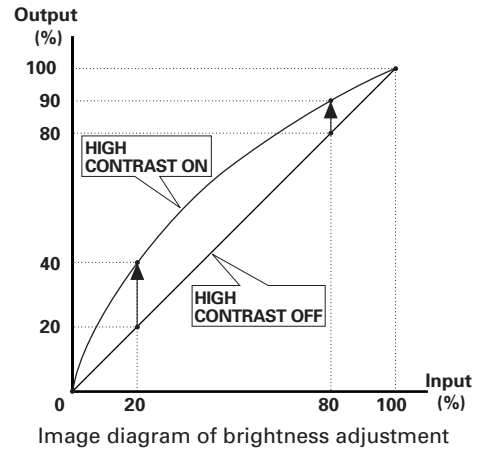

① Select SETUP.

Screen ①

```

MAIN MENU
PICTURE
SCREEN
ALL RESET
POWER SAVE
▶SET UP

MENU : MENU OFF
▲▼ : SELECT SET : NEXT
    
```

② Move the cursor over HIGH CONTRAST.

Change the setting using the SET button (each time you press the SET button HIGH CONTRAST will switch between ON and OFF).

Screen ②

```

SET UP
COLOR SYSTEM : AUTO
3D Y/C MODE  : MOTION
▶HIGH CONTRAST: OFF

EXIT
▲▼ : SELECT SET : CHANGE
    
```

In the case of INPUT 3 or INPUT 4, the following screen will be displayed.

```

SET UP
TERMINAL      : BNC
SETTING       : VIDEO
SIGNAL        : RGB
CLAMP         : MODE 1
▶HIGH CONTRAST : OFF

EXIT
▲▼ : SELECT SET : CHANGE
    
```

5) Setting up peripheral equipment

The unit is equipped with a function for automatically identifying whether the input signal is a PC signal or a video signal from something like a DVD player from the input signal frequency. However in the case of 31.5k / 60Hz video signal input or 640 x 480 / 60Hz PC signal input this function does not operate. In such cases, it is necessary to switch over the setting manually.

This setting needs to be made separately for INPUT 3 and INPUT 4.

- (Examples)
- When connecting AV unit → SETTING : VIDEO
 - When connecting PCs → SETTING : PC

Set-able condition : INPUT 3 or 4
 31.5 Hz horizontal, 60 Hz vertical at signal input time (no automatic switching)

Factory preset : INPUT 3 : PC
 INPUT 4 : PC

① Select SETUP.

② Move the cursor to SETTING and change the setting using the SET button. Pressing the SET button toggles the setting between VIDEO and PC.

Screen ①

MAIN MENU
 PICTURE
 SCREEN
 ALL RESET
 POWER SAVE
 ►SET UP

MENU : MENU OFF
 ▲▼ : SELECT SET : NEXT

Screen ②

SET UP
 TERMINAL : BNC
 ►SETTING : VIDEO
 SIGNAL : RGB
 CLAMP : MODE 1
 HIGH CONTRAST : OFF

EXIT
 ▲▼ : SELECT SET : CHANGE

(NOTE) No setting of INPUT 1 and 2 possible
 (INPUT 1 and 2 do not correspond to PC signal)

Menu Mode

6) Setting the input signal format

INPUT 3 and 4 support RGB and two component video signal types. Thus, you must make the appropriate setting for the particular component.

This setting needs to be made separately for INPUT 3 and 4, as described below.

- (Examples)
- To reproduce RGB signals → SIGNAL : RGB
 - To reproduce HDTV equipments → SIGNAL : COMPONENT 1
 - To reproduce DVD players → SIGNAL : COMPONENT 2

Set-able condition : When reproducing video signals (other than PC signals) via INPUT 3 or 4. (For PC signals, input setting is RGB.)

Factory preset : INPUT 3 : RGB
INPUT 4 : RGB

① Select SETUP.

② Move the cursor to SIGNAL and change the setting using the SET button.
Pressing the SET button moves the settings through the sequence RGB→COMPONENT 1→COMPONENT 2...

Screen ①

```
MAIN MENU
PICTURE
SCREEN
ALL RESET
POWER SAVE
▶SET UP

MENU : MENU OFF
▲▼ : SELECT SET : NEXT
```

Screen ②

```
SET UP
TERMINAL : BNC
SETTING : VIDEO
▶SIGNAL : RGB
CLAMP : MODE 1
HIGH CONTRAST : OFF

EXIT
▲▼ : SELECT SET : CHANGE
```

7) Setting the clamp position

Plugging in RGB (G ON SYNC) signals and a sync signal simultaneously may produce inappropriate intensity reproduction, with an over-bright screen or images with a greenish cast. If this occurs, set "CLAMP : MODE 2". For most situations, leave "CLAMP : MODE 1".

Clamp pulse (a timing pulse necessary for intensity reproduction), is generated in two ways, "a" and "b", as shown in Figure 1.

Figure 1: Generation of a clamp pulse

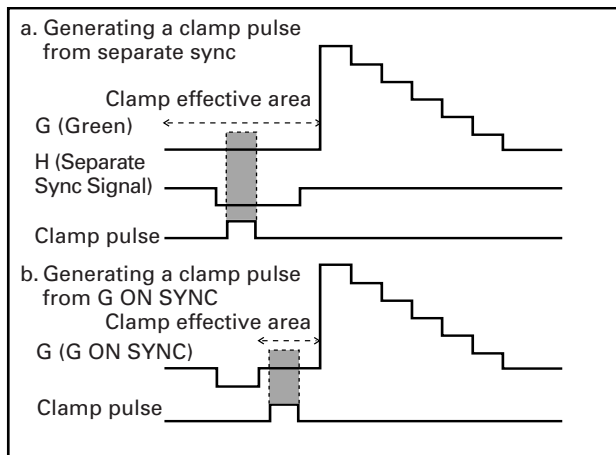
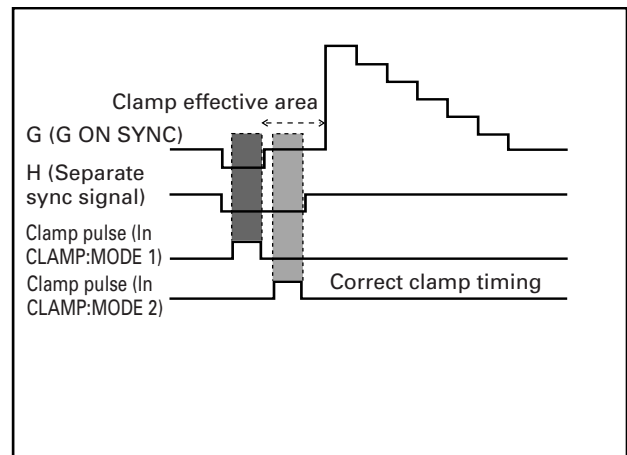

Figure 2: When a sync signal is supplied simultaneously with G ON SYNC



Sync signals are monitored in "CLAMP : MODE 1", and the unit is automatically switched to generate a clamp pulse by method "a" shown in Figure 1 in the presence of sync signal, and by method "b" in the absence of a sync signal. But when a sync signal is fed simultaneously with G ON SYNC, the unit perceives a sync signal, and generates a clamp pulse as shown in "a" in Figure 1. The generated clamp pulse is mis-timed, making correct reproduction of intensity impossible.

In this case, unplug the sync signal or set "CLAMP : MODE 2".

In "CLAMP MODE 2", the clamp pulse is generated by pulse "b" in Figure 1, whether or not a sync signal is present, ensuring correct reproduction of intensity.

(NOTE) The figures above are for illustrative purposes only.

(NOTE) Please regard the case of composite sync input as being the same as the case of separate sync input.

Set-able condition:
 RGB signal received via INPUT 3 or 4.
 Factory preset: INPUT 3 : MODE 1
 INPUT 4 : MODE 1

① Select SETUP.

Screen ①

```

MAIN MENU
PICTURE
SCREEN
ALL RESET
POWER SAVE
▶SET UP

MENU : MENU OFF
▲▼ : SELECT SET : NEXT
    
```

② Move the cursor to CLAMP, and use the SET button to change the setting.

Pressing the SET button toggles clamp mode between MODE 1 and MODE 2.

Screen ②

```

SET UP
TERMINAL : D-SUB
SETTING  : PC
SIGNAL   : RGB
▶CLAMP   : MODE 1
ABL      : OFF
H. ENHANCE : 0
V. ENHANCE : 0

EXIT
▲▼ : SELECT SET : CHANGE
    
```

(NOTE) No setting possible during input of component image signals

Menu Mode

8) ABL ON/OFF

Setting ABL: ON during playback of PC signals increases screen brightness.

If you set "ABL to ON" then the peak brightness will rise, and in addition the brightness of the pictures produced by input signals will change.

If the change is unsatisfactory, set ABL: OFF.

Differences between ABL ON and OFF (illustration):

ABL: OFF

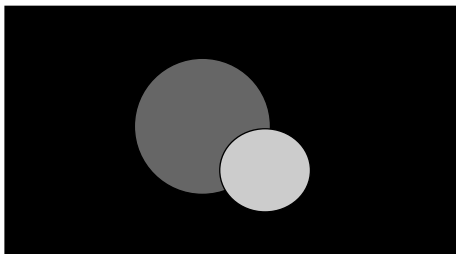
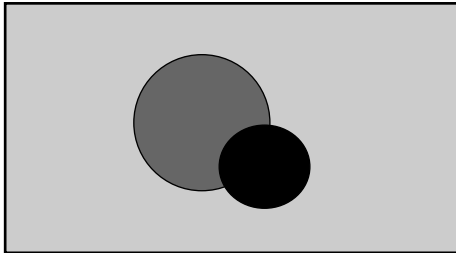

The intensity levels of input signals are faithfully reproduced.

ABL: ON

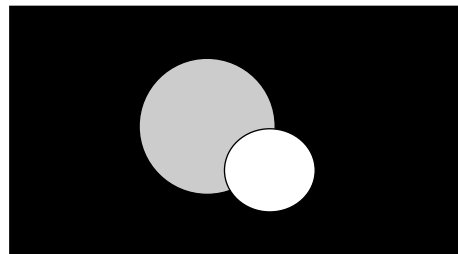
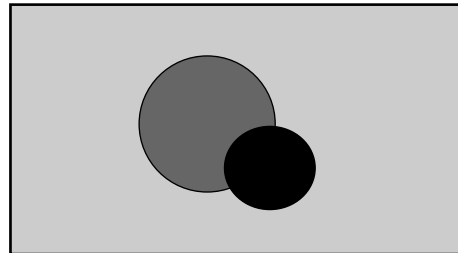

For images with relatively high overall brightness, no significant change occurs (upper figure). But for dimmer images, peak intensity images are brighter when reproduced (lower figure).

Set-able condition : PC signals supplied.
Factory preset : ON

① Select SETUP.

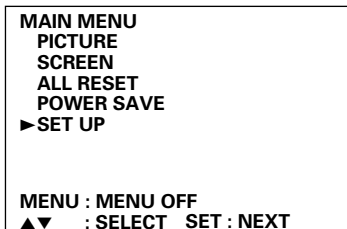

② Move the cursor to ABL and use the SET button to change the current setting.

Pressing the SET button toggles between ON and OFF.

Screen ②

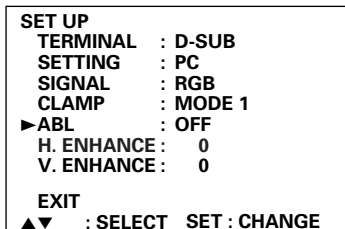

9) H/V enhancement tuning

H/V enhancement tuning may be used to adjust picture sharpness for PC input signals. Horizontal and vertical sharpness may be adjusted independently. Note that sharpness control is particularly effective when displaying enlarged XGA, SVGA, or VGA input or when displaying compressed SXGA or UXGA input.

Note: Setting the sharpness level too high may result in the outlines of text or other elements displayed to appear unnatural.

Requirements : Sharpness level may be adjusted only for PC signal input.
 Factory preset : 0 (neutral setting)

① Select SET UP.

Screen ①

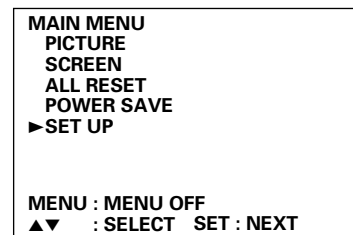

② Move the cursor to H. ENHANCE or V. ENHANCE and then press the SET button to make the specified selection.

Screen ②

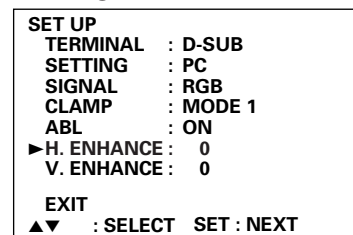

③ Adjust the sharpness level as desired. The horizontal sharpness level may be adjusted by using the ◀ or ▶ keys on the main unit or on the remote control unit. (The ▲ and ▼ keys are similarly used to adjust the v. ENHANCE level.)

Screen ③

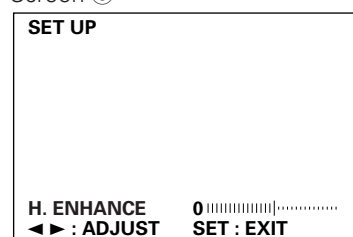

<Adjustment level (range)> H. ENHANCE, V. ENHANCE : ±32

Menu Mode

5.3.4 Menu layers

1) Video signal input

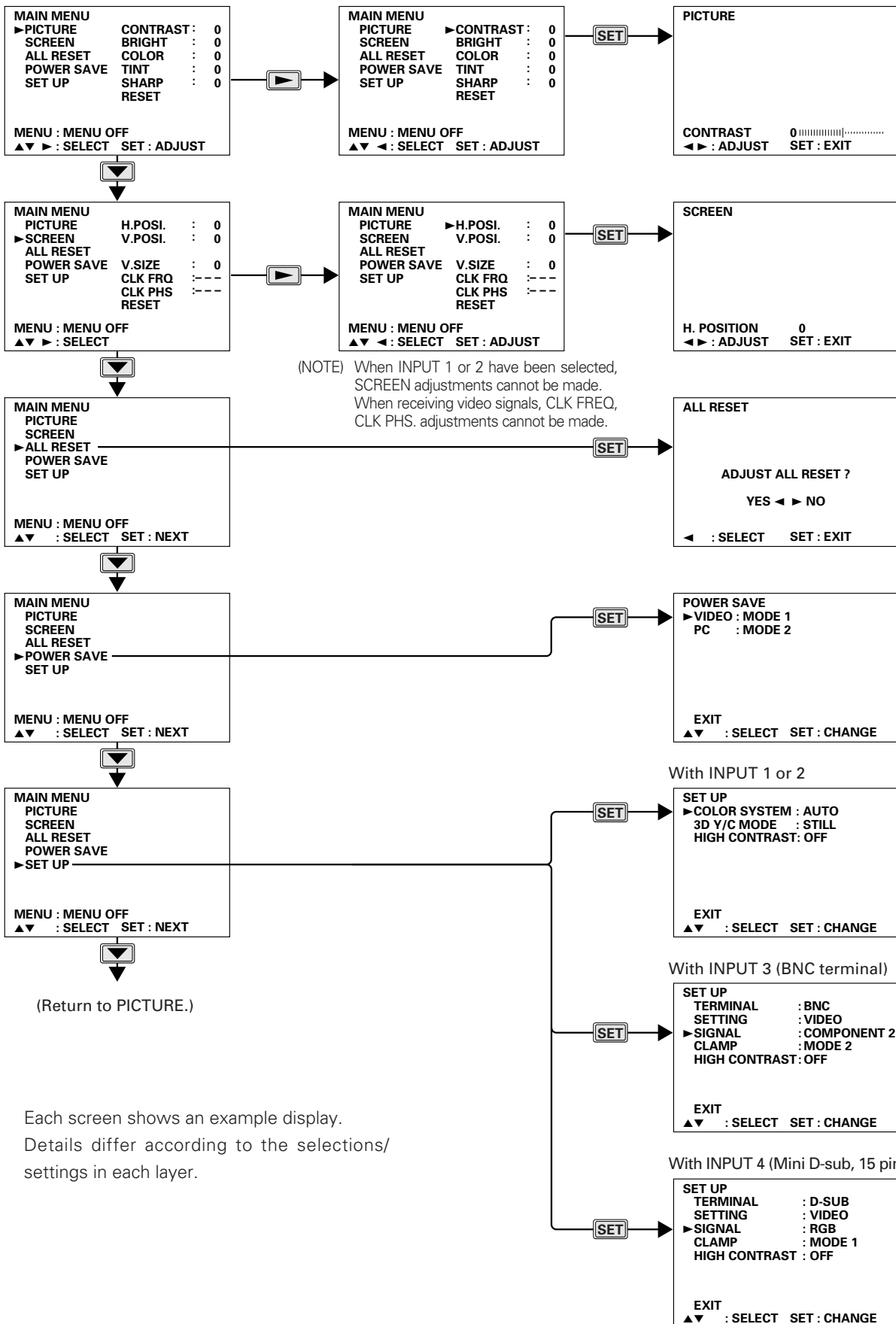

2) PC signal input

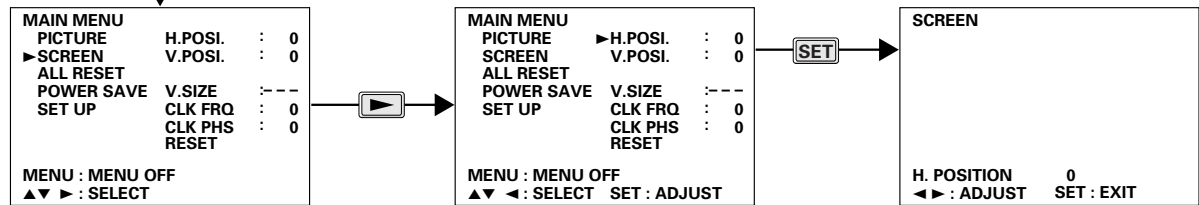
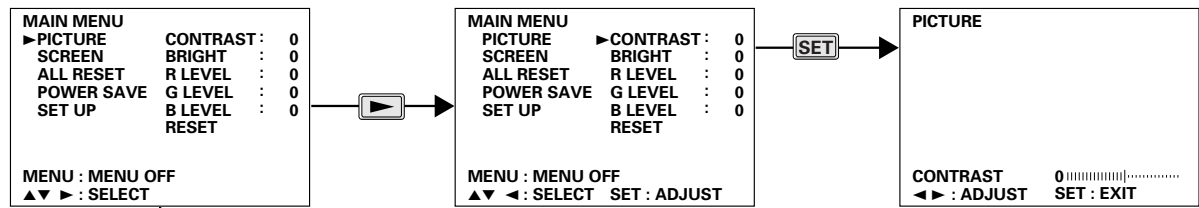

(NOTE) When PC signal input is being received, adjustments cannot be made to V.SIZE.

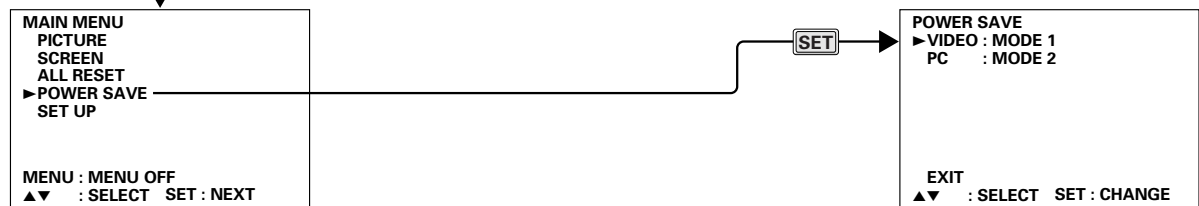
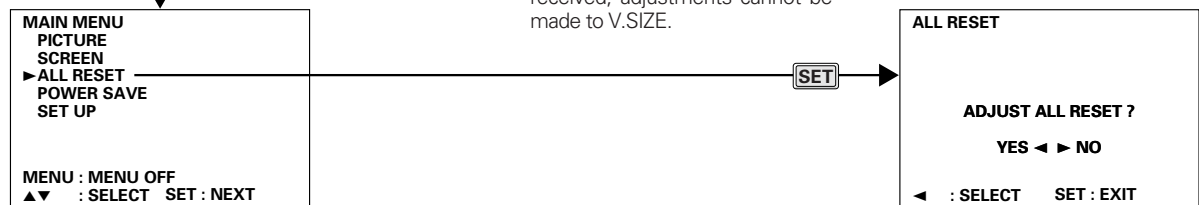

With INPUT 3 (BNC terminal) selected

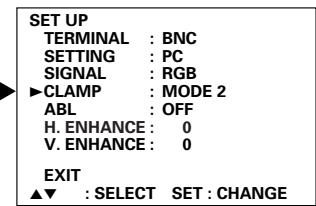

With INPUT 4 (Mini D-sub, 15 pin) selected

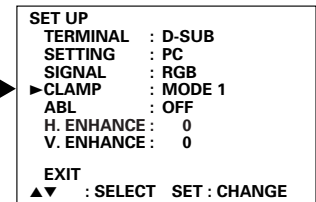

(Return to PICTURE.)

Each screen shows an example display.
Details differ according to the selections/
settings in each layer.

Integrator Mode

5.4 Integrator Mode

5.4.1 About the integrator mode

1) How to enter integrator mode

- Place the unit in integrator mode by doing the following:

Procedure: In standby, switch on power to the unit using the remote control or the operating panel of the main unit, as follows:

MENU button → POWER button

(This procedure should be complete in three seconds.)

2) Upon entering the integrator mode

- With the exception of CLK PHS, all PICTURE and SCREEN adjustments made in menu mode will be cancelled, with the values returning to the center values.

3) When you make adjustments in integrator mode:

- The various adjustment values for PICTURE, WHITE BALANCE and SCREEN (see 5.4.3 1) to 3)) will be stored separately for each input function and each type of input signal. In the case of PC signal input, however, values can be stored for only 4 types of input signal (signal frequency) for each input function. If adjustment is carried out for a fifth type of input signal then the oldest adjustment data is erased from memory.
- For more details please refer to "5.4.5 PICTURE and WHITE BALANCE adjustment values memory area tables" and "5.4.6 SCREEN adjustment values memory area tables".

4) To exit integrator mode

- Press the MENU button on the remote control or on the operating panel of the main unit to restore the unit to normal operating mode.

5) NOTES:

(1) The input can't be switched while in the integrator mode.

Make sure you have switched to the appropriate input before entering the integrator mode.

It is also important to plug in signals beforehand.

(2) Integrator mode is cancelled automatically in all of the following situations, returning to normal operating mode.

- When switching over to another input signal mode (i.e., to another signal frequency)
- When no operation occurs for a period of approximately three minutes
- When you press the KEY LOCK/UNLOCK button on the operating panel of the main unit

(3) For adjustments and settings, feed video signals that you will actually use into the production run.

5.4.2 Example of integrator mode operation

An example of adjustments of CONTRAST in the integrator mode is discussed below.

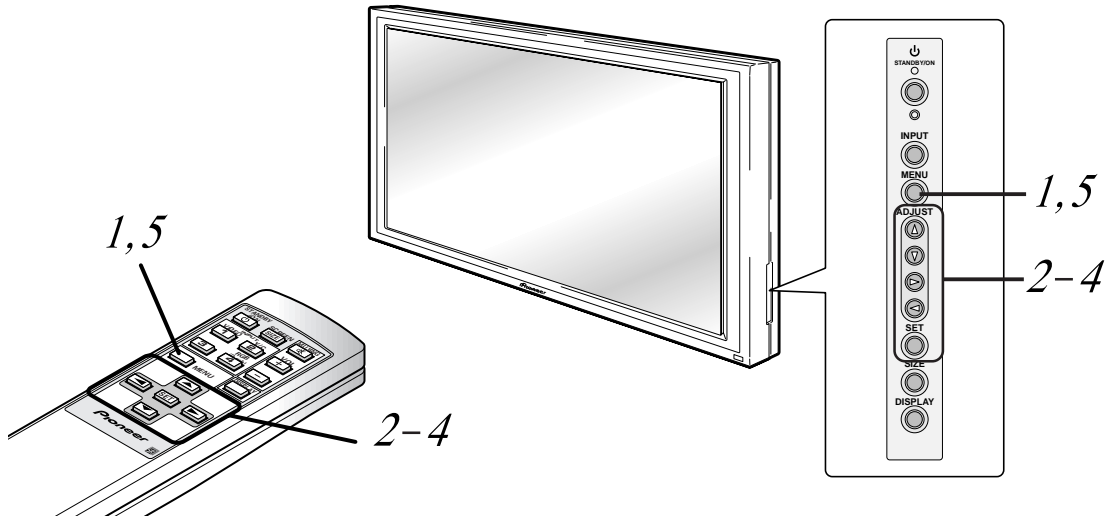

Step 1 Put the unit into standby, and do the following.

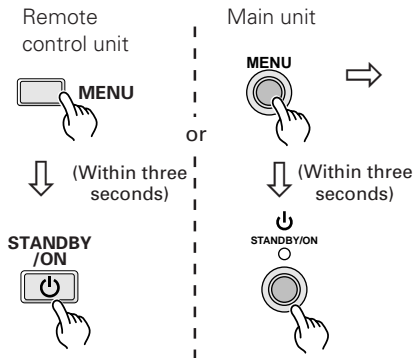

MENU	---
▶ PICTURE	CONTRAST : 128
WHITE BAL.	BRIGHT : 128
SCREEN	COLOR : 32
SIDE MASK	TINT : 32
OPTION 1	H. SHARP : 128
OPTION 2	V. SHARP : 128
SUB VOLUME	DEFAULT
ALL DEFAULT	

The currently selected item is highlighted in heliotrope.

Step 2 Select the item to adjust.

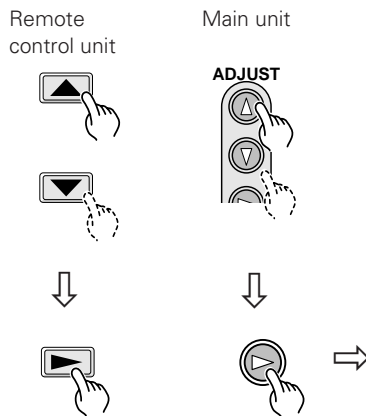

MENU	---
▶ PICTURE	CONTRAST : 128
WHITE BAL.	BRIGHT : 128
SCREEN	COLOR : 32
SIDE MASK	TINT : 32
OPTION 1	H. SHARP : 128
OPTION 2	V. SHARP : 128
SUB VOLUME	DEFAULT
ALL DEFAULT	

The currently selected item is highlighted in heliotrope.

Integrator Mode

Step 3 Select CONTRAST.

3

Remote control unit



Main unit

ADJUST



MENU	--
PICTURE	▶ CONTRAST : 128
WHITE BAL.	BRIGHT : 128
SCREEN	COLOR : 32
SIDE MASK	TINT : 32
OPTION 1	H. SHARP : 128
OPTION 2	V. SHARP : 128
SUB VOLUME	DEFAULT
ALL DEFAULT	

Step 4 Make adjustments.

4

Remote control unit



Main unit



PICTURE	--
CONTRAST	128

Press the SET button to return to the screen in Step 3.

To continue to make other adjustments, repeat Steps 3 to 4.

Step 5 To complete your adjustments, exit integrator mode.

5

Remote control unit



or



Main unit



or



⇒ Entering normal operating mode.

⇒ Entering STANDBY.

Although it is possible to exit integrator mode in other ways, such as by switching off the main power, we advise following the procedures shown at the left, in order to ensure that your adjustments are saved to memory.

5.4.3 Adjustments and settings in the integrator mode

For detailed information on button operations, refer to section 5.4.2, "Example of integrator mode operation".

1) Adjusting the PICTURE

The items that can be adjusted here are CONTRAST, BRIGHT, COLOR, TINT, H. SHARP and V. SHARP. These are slightly different to the items that can be adjusted in the case of PICTURE adjustments from menu mode (see the instruction manual).

- ① Before entering the integrator mode, switch the unit to the specific input (one of INPUTs 1 to 4) in which adjustments will be made.

(Refer to section 5.4.1, "About the integrator mode".)

The ID number of the unit of items will be indicated in the upper right corner of the screen, where "--" is displayed in the illustration.

Select PICTURE.

Screen ①



MENU	CONTRAST	: 128	--
▶ PICTURE	BRIGHT	: 128	
WHITE BAL.	COLOR	: 32	
SCREEN	TINT	: 32	
SIDE MASK	H. SHARP	: 128	
OPTION 1	V. SHARP	: 128	
OPTION 2	DEFAULT		
SUB VOLUME			
ALL DEFAULT			

- ② Select the desired adjustment item.

Select DEFAULT on Screen ② to return all of the PICTURE adjustment values to their factory preset values.

Push the ◀ button on the remote control or the operating panel of the main unit to return to screen ①.

Screen ②



MENU	CONTRAST	: 128	--
▶ PICTURE	BRIGHT	: 128	
WHITE BAL.	COLOR	: 32	
SCREEN	TINT	: 32	
SIDE MASK	H. SHARP	: 128	
OPTION 1	V. SHARP	: 128	
OPTION 2	DEFAULT		
SUB VOLUME			
ALL DEFAULT			

- ③ Make the necessary adjustments.

(NOTE) When in INPUT 3 or 4 (while receiving PC signals), COLOR, TINT, H. SHARP, and V. SHARP adjustments cannot be performed.

Make the adjustments using the ◀ and ▶ buttons on the remote control or the operating panel of the main unit.

The values selected here become the center values for adjustment in menu mode. Moreover, if you adjust SHARP in menu mode then the amount adjusted will be added to both the H. SHARP and the V. SHARP adjustment values in integrator mode.

Press the SET button to return to screen ②.

Screen ③



PICTURE			--
CONTRAST	128		

<Adjustable range> 0 to 255 for CONTRAST, BRIGHT, H. SHARP, and V. SHARP
0 to 63 for COLOR and TINT

Integrator Mode

2) Adjusting the WHITE BALANCE

The items that can be adjusted here are R HIGH, G HIGH, B HIGH, R LOW, G LOW and B LOW.

- ① Before entering the integrator mode, switch the unit to the specific input (one of INPUTs 1 to 4) in which adjustments will be made (refer to section 5.4.1, "About the integrator mode").

The ID number of the set of items will be indicated in the upper right corner of the screen, where "--" is displayed in the illustration.

Select WHITE BALANCE.

Screen ①

MENU		--
PICTURE	R HIGH	: 128
▶ WHITE BAL.	G HIGH	: 128
SCREEN	B HIGH	: 128
SIDE MASK	R LOW	: 128
OPTION 1	G LOW	: 128
OPTION 2	B LOW	: 128
SUB VOLUME	DEFAULT	
ALL DEFAULT		

- ② Select the desired adjustment item.

Select DEFAULT on Screen ② to return all of the WHITE BALANCE adjustment values to their factory preset values. Push the ◀ button on the remote control or the operating panel on the main unit to return to screen ①.

Screen ②

MENU		--
PICTURE	▶ R HIGH	: 128
WHITE BAL.	G HIGH	: 128
SCREEN	B HIGH	: 128
SIDE MASK	R LOW	: 128
OPTION 1	G LOW	: 128
OPTION 2	B LOW	: 128
SUB VOLUME	DEFAULT	
ALL DEFAULT		

- ③ Make the necessary adjustments.

Make the adjustments using the ◀ and ▶ buttons on the remote control or the operating panel of the main unit.

Press the SET button to return to screen ②.

<Adjustable range> 0 to 255 for every item

Screen ③

WHITE BALANCE		--
R HIGH	128	

3) Adjusting the SCREEN

The items that can be adjusted here are H.POSITION, V.POSITION, V.SIZE, CLK FREQ and CLK PHASE.
(NOTE) With this unit, H. SIZE cannot be adjusted.

- ① Before entering the integrator mode, switch the unit to the specific input (one of INPUTs 1 to 4) in which adjustments will be made (refer to section 5.4.1, "About the integrator mode").

The ID number of the unit of items will be indicated in the upper right corner of the screen, where "--" is displayed in the illustration.

Select SCREEN.

Screen ①



MENU		--
PICTURE	H. POSI.	: 128
WHITE BAL.	V. POSI.	: 128
▶SCREEN		
SIDE MASK	V. SIZE	:---
OPTION 1	CLK FRQ	: 128
OPTION 2	CLK PHS	: 8
SUB VOLUME	DEFAULT	
ALL DEFAULT		

- ② Select the desired adjustment item.

Select DEFAULT on Screen ② to return all of the SCREEN adjustment values to their factory preset values (center values).

Push the ◀ button on the remote control or operating panel on the main unit to return to screen ①.

Screen ②



MENU		--
PICTURE	▶H. POSI.	: 128
WHITE BAL.	V. POSI.	: 128
SCREEN		
SIDE MASK	V. SIZE	:---
OPTION 1	CLK FRQ	: 128
OPTION 2	CLK PHS	: 8
SUB VOLUME	DEFAULT	
ALL DEFAULT		

- ③ Make the necessary adjustments.

(NOTE) V.SIZE can only be adjusted when video signals are being received. CLK FREQ and CLK PHASE can only be adjusted when PC signals are being received.

(NOTE) Three SCREEN parameter settings are required for each display screen size when displaying 1280 x 1024 / 60 Hz input. (① For the 4:3 TYPE screen size, ② For the FULL TYPE screen size, ③ For the ZOOM screen size)

Screen ③



SCREEN		--
H.POSITION	128	

Adjustments can be made using the ◀ and ▶ buttons (or the ▲ and ▼ buttons for V.POSITION and V.SIZE) on the remote control or the operating panel of the main unit.

Values set and adjusted for H.POSITION, V.POSITION, V.SIZE, and CLK FRQ. serve as median values when adjustments are made in the menu mode.

CLK PHASE uses the same data as in menu mode.

Press the SET button to return to Screen ②.

<Adjustable Range> 0 to 255 (median 128) for H.POSITION and V.POSITION
64 to 191 (median 128) for V.SIZE, CLK FREQ
0 to 16 (median 8) for CLK PHASE

<Adjusting Order> For the sake of efficiency, make adjustments in the following order:
V.POSITION → H.POSITION → CLK FREQ → H.POSITION → CLK PHASE

Integrator Mode

4) Adjusting the side mask

The side mask adjusts the brightness of no-image areas appearing on the fringe of the screen when the screen size is set to 4 : 3 NORMAL or to ORIGINAL, for example.

The brightness of each color of RGB can be adjusted separately.

In adjusting the side mask, think of how video signals develop with time, and also of a balance in brightness between the adjacent display sets.

(NOTE) During adjustment, a striped pattern may appear on the mask. This is not a fault.

- ① Enter the integrator mode. (refer to section 5.4.1, "About the integrator mode").

The ID number of the unit of items will be indicated in the upper right corner of the screen, where "--" is displayed in the illustration.

Select SIDE MASK.

Screen ①

MENU		--
PICTURE	R LEVEL	: 128
WHITE BAL.	G LEVEL	: 128
SCREEN	B LEVEL	: 128
▶SIDE MASK		
OPTION 1		
OPTION 2		
SUB VOLUME		
ALL DEFAULT		

- ② Select the desired adjustment item.

The screen size may momentarily switch.

Press the ◀ button on the main unit operation panel in order to return from Screen ② to Screen ①.

Screen ②

MENU		--
PICTURE	▶R LEVEL	: 128
WHITE BAL.	G LEVEL	: 128
SCREEN	B LEVEL	: 128
SIDE MASK		
OPTION 1		
OPTION 2		
SUB VOLUME		
ALL DEFAULT		

- ③ Select the desired option.

Make the adjustments using the ◀ and ▶ buttons on the remote control or the operating panel of the main unit.

Press the SET button to return to screen ②.

<Adjustable range> 0 to 255 for every item

SIDE MASK applies to all inputs (INPUTs 1 to 4).

Screen ③

SIDE MASK		--
R LEVEL	128	

Note that with side mark adjustment, there is no function for returning to the initial values (DEFAULT). Please take due caution.

(NOTE) In the case that display with a side mask is impossible (for example in the case of high vision TV (HDTV) signal input etc.) side mask adjustment cannot be carried out.

5) Setting the color mode

In addition to COLOR MODE 1, which is for normal use, this unit also has the independent COLOR MODE 2, for which the PICTURE and WHITE BALANCE adjustment values have been set to the optimum values for TV studio retakes. (See '5.4.5 PICTURE and WHITE BALANCE adjustment values memory area tables')

Please change the COLOR MODE setting according to the use.

Factory preset : COLOR MODE 1

- ① Enter the integrator mode (refer to section 5.4.1, "About the integrator mode").

The ID number of the unit of adjustment items will be indicated in the upper right corner of the screen where "--" is displayed in the illustration.

Select OPTION 1.

Screen ①

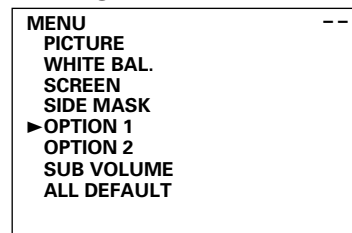

- ② Move the cursor to COLOR MODE, and select the desired color mode with the SET button.

Pressing the SET button toggles the color mode between 1 and 2.

When you switch the COLOR MODE, all of the input functions and the PICTURE and WHITE BALANCE adjustment values for the input signal switch over all at once.

COLOR MODE affects every input (INPUTs 1 to 4).

Select EXIT in screen ② to return to screen ①.

Screen ②

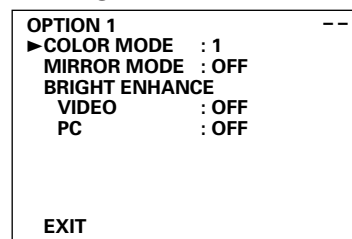

(NOTE) The current color mode can be identified by the ID display color.

Cyan: COLOR MODE : 1

White: COLOR MODE : 2

Integrator Mode

6) Setting the mirror mode

This function permits displayed images to be reversed in any fashion.

- Normal playback → MIRROR MODE: OFF
- Left/right reversed playback → MIRROR MODE: X
- Up/down reversed playback → MIRROR MODE: Y
- Up/down/left/right reversed playback → MIRROR MODE: XY

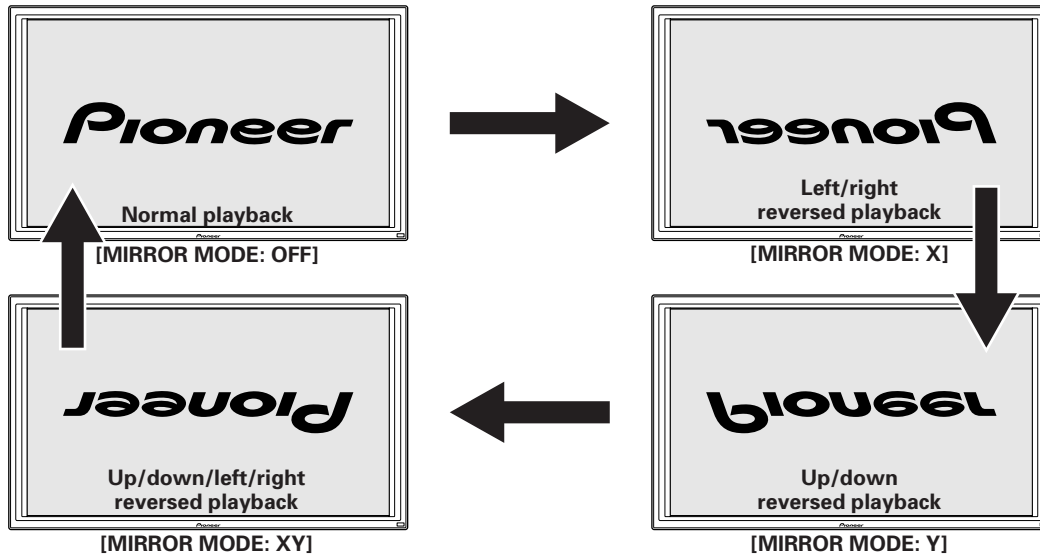

MIRROR MODE: XY is intended for smart cable arrangement, making it possible to draw bundled cables upward (towards the ceiling) when this display is mounted upside-down using the ceiling suspension hardware PDK-5002.

(NOTE) In using the PDK-5002 mounting hardware, observe the operating temperature restrictions and other limitations specified in section 4.4, "Plasma Display Ceiling Suspension Hardware: PDK-5002".

Factory preset: MIRROR MODE: OFF

- ① Enter the integrator mode (refer to section 5.4.1, "About the integrator mode").

The ID number of the unit of adjustment items will be indicated in the upper right corner of the screen, where "--" is displayed in the illustration.

Select OPTION 1.

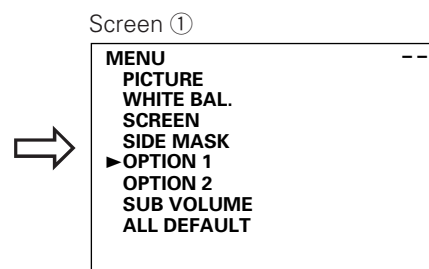

- ② Move the cursor to "MIRROR MODE" and change the mode with the SET button.

Pressing the "SET" button toggles the mode from "Off" → "X" → "Y" → "XY" → then back to "Off" and so on.

MIRROR MODE applies to all inputs (INPUTs 1 to 4).

Select EXIT in screen ② to return to screen ①.

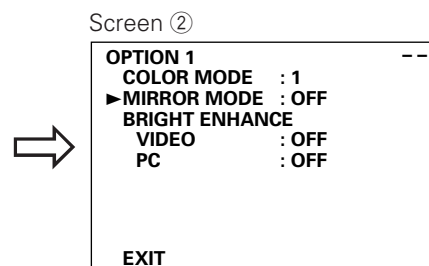

7) Setting the brightness enhancement at the screen center

Bright enhance is a function that enhances and/or corrects the brightness of the central part of the screen. This setting can be performed as described below while receiving video or PC signals.

- When it is desired to make the screen brighter → Set ON.
- When it is desired to restore the normal condition → Set OFF.

Factory preset: VIDEO : OFF
PC : OFF

- ① Enter the integrator mode (refer to section 5.4.1, "About the integrator mode".)

The ID number of the unit of adjustment items will be indicated in the upper right corner of the screen where "--" is displayed in the illustration.

Select OPTION 1.

Screen ①

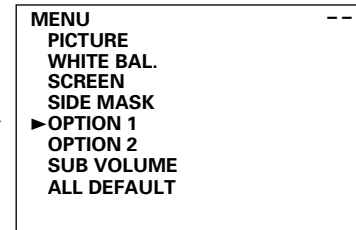

- ② Move the cursor to BRIGHT ENHANCE (VIDEO or PC), and change the mode with the SET button.

(NOTE) This is selected automatically in line with the current input signal type (video or PC).

Pressing the SET button toggles the BRIGHTNESS ENHANCE mode back and forth between ON and OFF.

BRIGHT ENHANCE (VIDEO or PC) applies to all inputs (INPUTs 1 to 4).

Select EXIT in screen ② to return to screen ①.

Screen ②

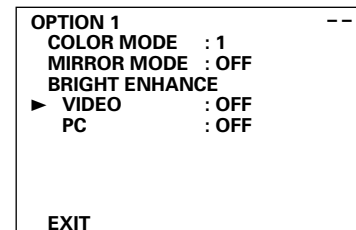

Integrator Mode

8) Setting OSD display

This is a function that suppresses the OSD display (INPUT display, etc.) in normal operating mode.

When "OSD: OFF" is set, the following OSD displays are enabled.

- ① MENU display (Menu mode, integrator mode, and RS-232C adjustment mode)
- ② Warning just before the Power Save feature comes on
- ③ High internal temperature warning (THERMAL WARNING! PLEASE SHUT DOWN.)
- ④ Display announcing KEY LOCK is set; also display announcing the setting of KEY LOCK/UNLOCK

When uneasy about automatically operating directions, etc., set OSD: OFF.

Factory preset : ON

- ① Enter the integrator mode (refer to section 5.4.1, "About the integrator mode").

The ID number of the unit of adjustment items will be indicated in the upper right corner of the screen, where "--" is displayed in the illustration.

Select OPTION 2.

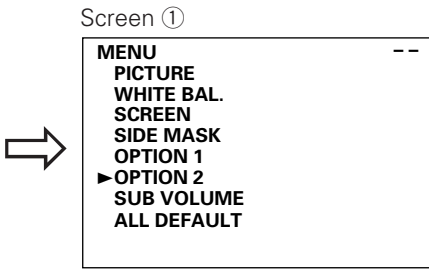

- ② Move the cursor to "OSD" and change the mode with the SET button.

Pressing the SET button toggles the OSD mode between ON and OFF.

OSD mode applies to all inputs (INPUTs 1 to 4).

Select EXIT in screen ② to return to screen ①.

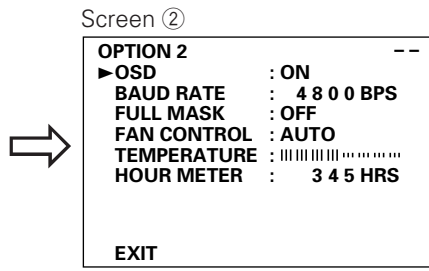

9) Setting the baud rate

When controlling or adjusting the unit from a PC, the RS-232C port can be set to one of five baud rates: 1200, 2400, 4800, 9600, and 19200 BPS.

Factory preset: 4800 BPS

- ① Enter the integrator mode (refer to section 5.4.1, "About the integrator mode").

The ID number of the unit of adjustment items will be indicated in the upper right corner of the screen, where "--" is displayed in the illustration.

Select OPTION 2.

Screen ①

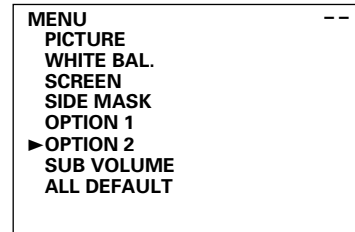

- ② Move the cursor to "BAUD RATE" and change the mode with the SET button.

You can cycle through the available values by repeatedly pressing the SET button:

1200 BPS → 2400 BPS → 4800 BPS → 9600 BPS → 19200 BPS → ...

Screen ②

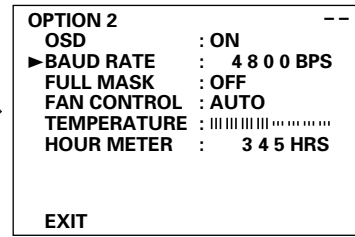

BAUD RATE applies to all inputs (INPUTs 1 to 4).

Select EXIT in screen ② to return to screen ①.

Set the unit baud rate to match that of the PC in use.

With long RS-232C cables, we recommend using lower baud rates.

Integrator Mode

10) Setting FULL MASK

This is a function for turning the whole screen a single color - white, red, green or blue - using a PDP internal signal. If FULL MASK is set to any setting other than OFF then display of external input signals becomes impossible. The FULL MASK feature may be used to wipe out to some extent images which have been burnt into the screen. (Note, however, that it is impossible to completely eliminate such images.) For more details please refer to "5.8 Regarding the problem of images becoming burnt onto the screen".

Factory preset : OFF

- ① Enter the integrator mode (refer to section 5.4.1, "About the integrator mode").

The ID number of the unit of adjustment items will be indicated in the upper right corner of the screen, where "--" is displayed in the illustration.

Select OPTION 2.

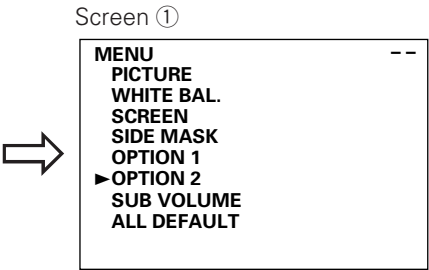

- ② Move the cursor to "FULL MASK" and change the mode with the SET button.

You can cycle through the available values by repeatedly pressing the SET button:
OFF → ON → RED → GREEN → BLUE → ...

FULL MASK applies to all inputs (INPUTs 1 to 4).

Select EXIT in screen ② to return to screen ①.

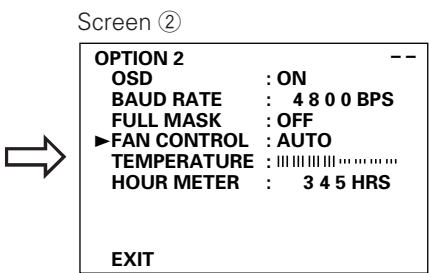

11) Setting the cooling fan control formula

The back of the main unit is equipped with cooling fans.

With this function, the control formats of the fans can be switched.

To have the fans automatically controlled according to an internal temperature sensor → set AUTO.

To set a fixed maximum number of revolutions (cut automatic control) → set FIXED (MAX).

(NOTE) The FIRED (MAX) setting is useful in the case that the unit has been installed in a special environment.

In this case, however, the noise of the fan rotating will become large, and so you should take care over the installation environment (particularly if the unit is installed in a quiet place).

For more information, please refer to Chapter 3, "Installation".

Factory preset : AUTO

- ① Enter the integrator mode (refer to section 5.4.1, "About the integrator mode").

The ID number of the unit of adjustment items will be indicated in the upper right corner of the screen, where "--" is displayed in the illustration.

Select OPTION 2.

Screen ①

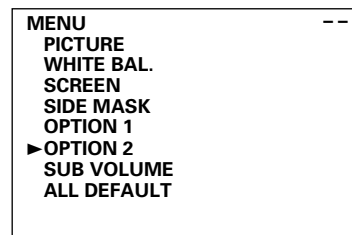

- ② Move the cursor to "FAN CONTROL" and change the mode with the SET button.

Repeatedly pressing the SET button toggles FAN CONTROL between AUTO and FIXED (MAX).

FAN CONTROL applies to all inputs (INPUTs 1 to 4).

Select EXIT in screen ② to return to screen ①.

Screen ②

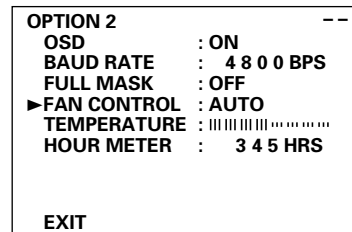

Integrator Mode

12) Checking the inside temperature

A temperature level display is provided to make it possible to easily check the internal temperature of the main unit.

- When GREEN is displayed → The internal temperature is OK.
When YELLOW or RED is displayed → The internal temperature is rather high. Turn the power supply to the set off, check the installation conditions immediately, and then take measures to dissipate heat through air conditioning etc.

CAUTION

When checking on the temperature, perform aging thoroughly, just as before adjustment. (A minimum of 30 minutes with a 100-percent white signal.) Do the same after checking on the effectiveness of heat dissipation measures.

For more information, refer to Chapter 3, "Installation".

- ① Enter the integrator mode (refer to section 5.4.1, "About the integrator mode").

The ID number of the unit of adjustment items will be indicated in the upper right corner of the screen, where "--" is displayed in the illustration.

Select OPTION 2.

Screen ①

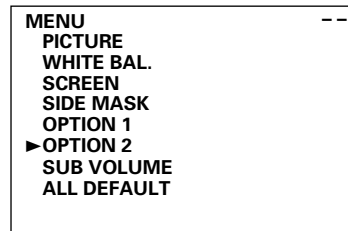

```
MENU --
PICTURE
WHITE BAL.
SCREEN
SIDE MASK
OPTION 1
▶OPTION 2
SUB VOLUME
ALL DEFAULT
```

- ② Select "TEMPERATURE" to check on the unit's internal temperature.

Select EXIT in screen ② to return to screen ①.

Screen ②

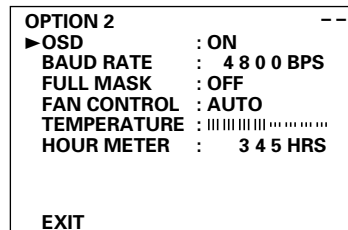

```
OPTION 2 --
▶OSD : ON
BAUD RATE : 4800 BPS
FULL MASK : OFF
FAN CONTROL : AUTO
TEMPERATURE : |||||
HOUR METER : 345 HRS

EXIT
```

13) Checking the accumulated ON time

This function displays the accumulated time during which power has been flowing into the unit (in 1 hour units).

CAUTION

Time when the unit is in standby mode is not included in the accumulated ON time.

- ① Enter the integrator mode (refer to section 5.4.1, "About the integrator mode").

The ID number of the set of adjustment items will be indicated in the upper right corner of the screen, where "--" is displayed in the illustration.

Select OPTION 2.

Screen ①

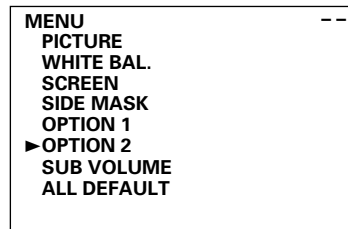

```
MENU --
PICTURE
WHITE BAL.
SCREEN
SIDE MASK
OPTION 1
▶OPTION 2
SUB VOLUME
ALL DEFAULT
```

- ② Select "HOUR METER" to check on the unit's accumulated ON time.

Select EXIT in screen ② to return to screen ①.

Screen ②

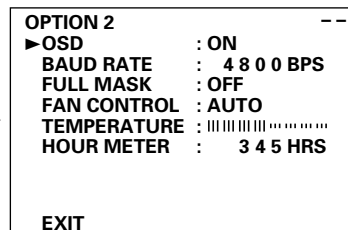

```
OPTION 2 --
▶OSD : ON
BAUD RATE : 4800 BPS
FULL MASK : OFF
FAN CONTROL : AUTO
TEMPERATURE : |||||
HOUR METER : 345 HRS

EXIT
```

14) Adjusting SUB VOLUME

This item can be used to individually adjust each sound level input.

It is convenient to use when adjusting level between different sources (for example, between a DVD player and a PC).

After first turning off muting, switch to integrator mode and then adjust the volume. The values to which SUB VOLUME can be adjusted depend on the current input function.

- When the current input function is INPUT 1 or INPUT 2: SUB VOLUME can be adjusted to INPUT 1 or INPUT 2
- When the current input function is INPUT 3 or INPUT 4: SUB VOLUME can be adjusted to INPUT 3 or INPUT 4

- ① Enter the integrator mode (refer to section 5.4.1, "About the integrator mode").

The ID number of the unit of adjustment items will be indicated in the upper right corner of the screen, where "--" is displayed in the illustration.

Select SUB VOLUME.

Screen ①

MENU			--
PICTURE	INPUT1	:	63
WHITE BAL.	INPUT2	:	63
SCREEN	INPUT3	:	63
SIDE MASK	INPUT4	:	63
OPTION 1	DEFAULT		
OPTION 2			
▶ SUB VOLUME			
ALL DEFAULT			



- ② Select the desired adjustment item.

By selecting DEFAULT on screen 2, you can return all of the SUB VOLUME adjustment values to their factory preset values (maximum: 63).

Use the ◀ button on the remote control or operating panel of the main unit to return to screen ①.

Screen ②

MENU			--
PICTURE	▶ INPUT1	:	63
WHITE BAL.	INPUT2	:	63
SCREEN	INPUT3	:	63
SIDE MASK	INPUT4	:	63
OPTION 1	DEFAULT		
OPTION 2			
SUB VOLUME			
DEFAULT			



- ③ Make the necessary adjustments.

Adjustments can be made using the ◀ and ▶ buttons on the remote control or the operating panel of the main unit.

Push the SET button to return to screen ②.

Screen ③

SUB VOLUME			--
INPUT1			63



<Adjustable range> 0 to 63 for all items

<Order of adjustments>

It is most efficient to make adjustments in the following order:

- ① VOLUME (normal operating mode) Raise the volume to that which you will actually use.
- ② SUB VOLUME (integrator mode) Makes adjustments by matching loud inputs to quiet inputs.

Integrator Mode

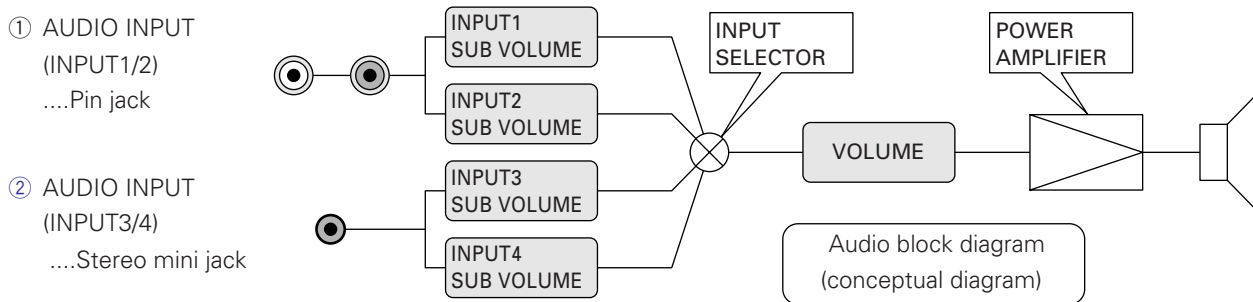

This unit is equipped with 2 audio input systems

No. 1 AUDIO INPUT (INPUTS 1 and 2): Pin jack

→ Is selected when either PICTURE INPUT 1 or 2 has been selected.

No. 2 AUDIO INPUT (INPUTS 3 and 4): Stereo mini jack

→ Is selected when either PICTURE INPUT 3 or 4 has been selected.

Use of SUB VOLUME: Example 1

In the case that a video deck is connected to INPUT 1 (pictures only) and a DVD player is connected to INPUT 2 (pictures and sound)

→ (Video input) When INPUT 1 or INPUT 2 has been selected, DVD player audio will be output.

Since sound is not required while a video is being played using the video deck (INPUT 1), you should set the SUB VOLUME for INPUT 1 to zero.

Use of SUB VOLUME: Example 2

In the case that a DVD player is connected to INPUT 2 (pictures and sound) and a PC is connected to INPUT 4 (pictures and sound)

→ If the difference in volume between the DVD player and the PC is irritating, adjust the SUB VOLUME for whichever is louder.

15) Initializing Adjustments (ALL DEFAULT)

You can restore items adjusted in the integrator mode to their factory-preset values.

You can reset all of the PICTURE, WHITE BALANCE and SCREEN adjustment values (refer to 5.4.3 1), 2) and 3)) to their factory preset values in one go.

- ① Before entering integrator mode, switch the unit to the input (INPUTs 1 to 4) with the parameters which you want to return to their original settings (refer to section 5.4.1, "About the integrator mode").

For initialization, use input signals that would be used in an actual production run.

Make sure that the current color mode is set to the mode in which you want to restore parameters to factory presets (refer to section 5.4.3, 5)).

The ID number of the unit of items will be indicated in the upper right corner of the screen, where "--" is displayed in the illustration.

Select DEFAULT.

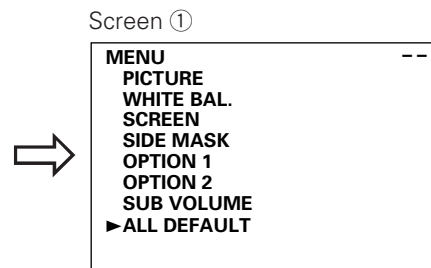

- ② Move the cursor to "YES" using the ◀ button on the remote control or the operating panel of the main unit, and press the SET button. This restores the following parameters to their factory-pre-set values, and returns the unit to screen ①.

- PICTURE parameters: refer to section 5.4.3, 1)
- WHITE BALANCE parameters: refer to section 5.4.3, 2)
- SCREEN parameters: refer to section 5.4.3, 3)

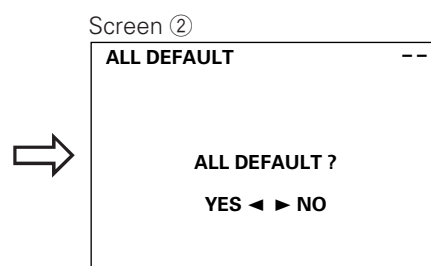

Move the cursor to "NO" and press the SET button to return to screen ① with remaining the adjustment values.

(NOTE) The following items may not be initialized.

Integrator mode:

- SIDE MASK
- OPTION 1 (all)
- OPTION 2 (all)
- SUB VOLUME

Menu mode:

- POWER SAVE
- SETUP (all)

Integrator Mode

5.4.4 Menu Layers

1) Video Signal Input

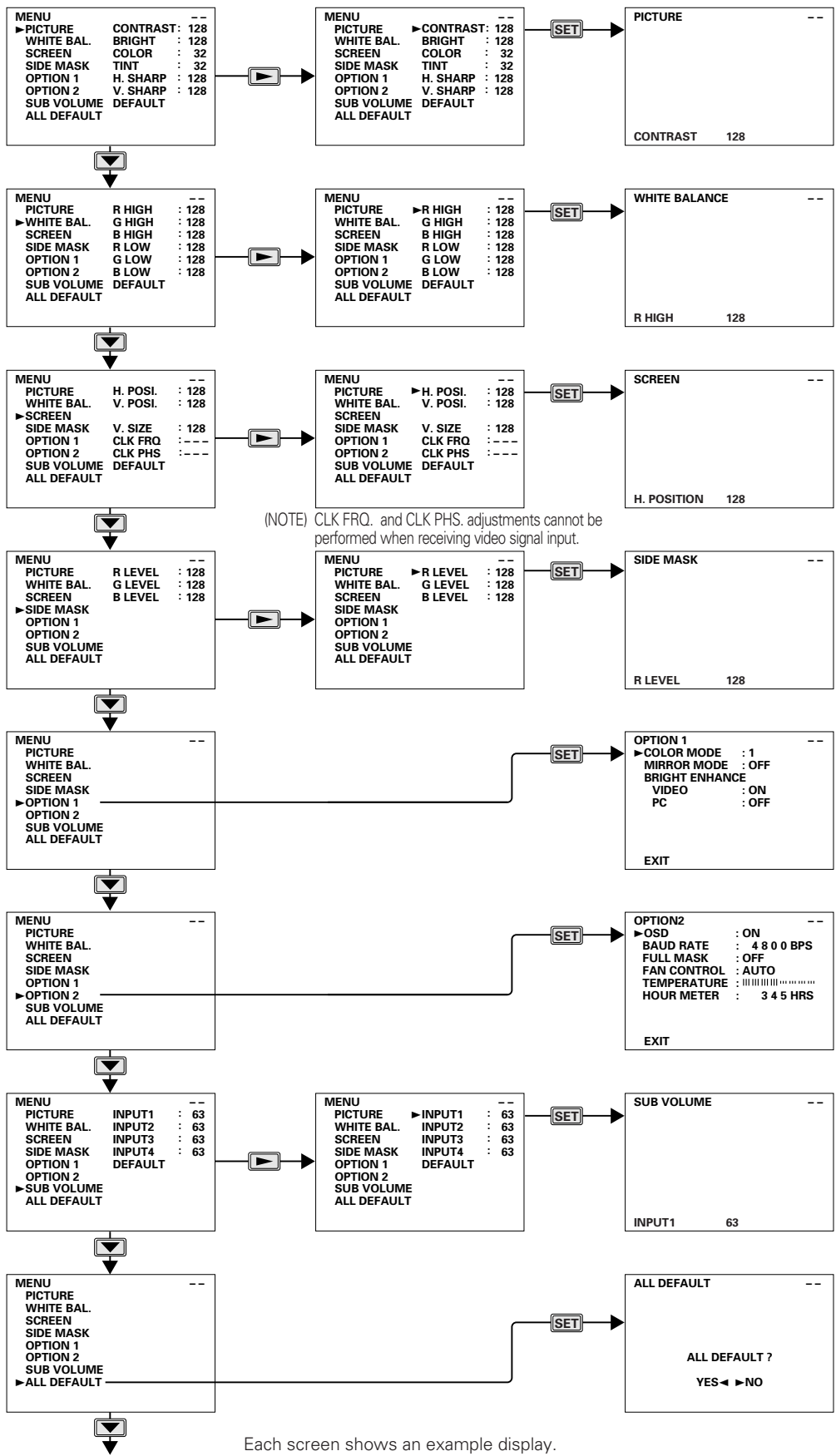

Each screen shows an example display. Details differ according to the selections/settings in each layer.

2) PC Signal Input

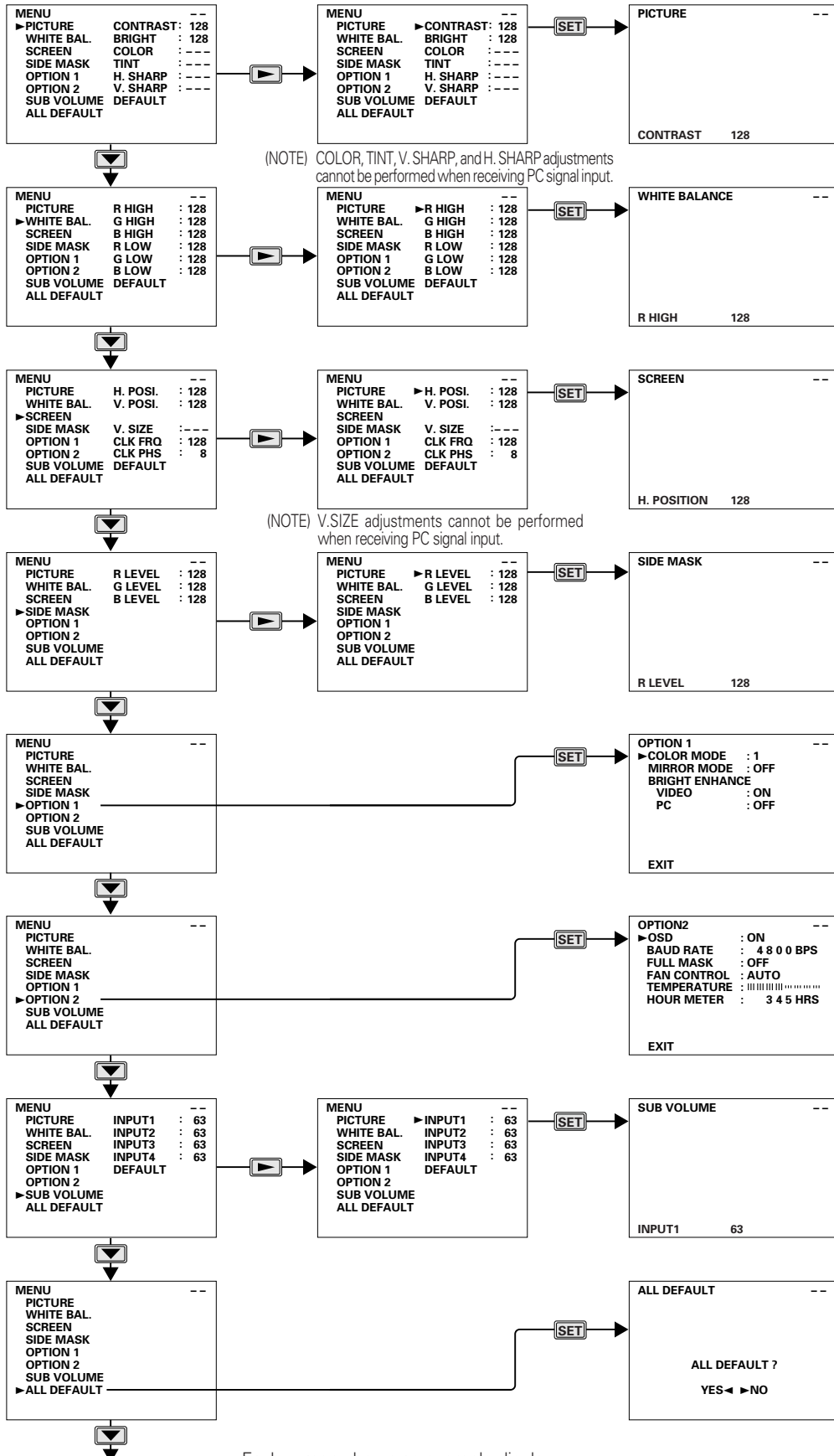

Each screen shows an example display. Details differ according to the selections/ settings in each layer.

Integrator Mode

5.4.5 PICTURE and WHITE BALANCE adjustment values memory area tables

The memory area tables used during PICTURE and WHITE BALANCE adjustment have the layout shown below. Color modes 1 and 2 are independent and so the PICTURE and WHITE BALANCE adjustment values for these two modes are stored in separate parts of memory. When you switch between color modes 1 and 2, the PICTURE and WHITE BALANCE adjustment values for all inputs switch over all at once.

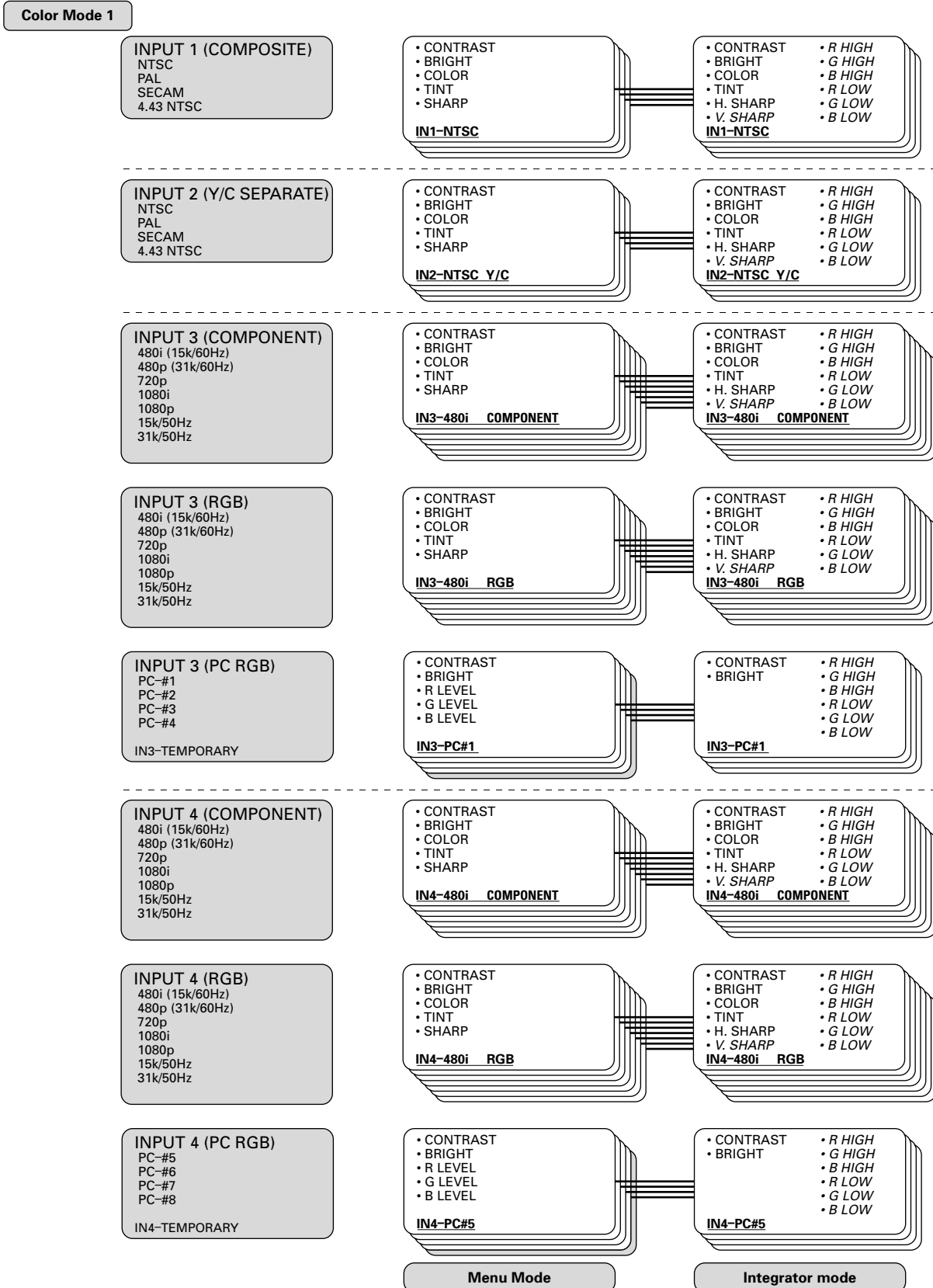

Color Mode 2

INPUT 1 (COMPOSITE)
 NTSC
 PAL
 SECAM
 4.43 NTSC

• CONTRAST
 • BRIGHT
 • COLOR
 • TINT
 • SHARP
IN1-NTSC

• CONTRAST
 • BRIGHT
 • COLOR
 • TINT
 • H. SHARP
 • V. SHARP
 • R HIGH
 • G HIGH
 • B HIGH
 • R LOW
 • G LOW
 • B LOW

INPUT 2 (Y/C SEPARATE)
 NTSC
 PAL
 SECAM
 4.43 NTSC

• CONTRAST
 • BRIGHT
 • COLOR
 • TINT
 • SHARP
IN2-NTSC Y/C

• CONTRAST
 • BRIGHT
 • COLOR
 • TINT
 • H. SHARP
 • V. SHARP
 • R HIGH
 • G HIGH
 • B HIGH
 • R LOW
 • G LOW
 • B LOW

INPUT 3 (COMPONENT)
 480i (15k/60Hz)
 480p (31k/60Hz)
 720p
 1080i
 1080p
 15k/50Hz
 31k/50Hz

• CONTRAST
 • BRIGHT
 • COLOR
 • TINT
 • SHARP
IN3-480i COMPONENT

• CONTRAST
 • BRIGHT
 • COLOR
 • TINT
 • H. SHARP
 • V. SHARP
 • R HIGH
 • G HIGH
 • B HIGH
 • R LOW
 • G LOW
 • B LOW

INPUT 3 (RGB)
 480i (15k/60Hz)
 480p (31k/60Hz)
 720p
 1080i
 1080p
 15k/50Hz
 31k/50Hz

• CONTRAST
 • BRIGHT
 • COLOR
 • TINT
 • SHARP
IN3-480i RGB

• CONTRAST
 • BRIGHT
 • COLOR
 • TINT
 • H. SHARP
 • V. SHARP
 • R HIGH
 • G HIGH
 • B HIGH
 • R LOW
 • G LOW
 • B LOW

INPUT 3 (PC RGB)
 PC-#1
 PC-#2
 PC-#3
 PC-#4
 IN3-TEMPORARY

• CONTRAST
 • BRIGHT
 • R LEVEL
 • G LEVEL
 • B LEVEL
IN3-PC#1

• CONTRAST
 • BRIGHT
 • R HIGH
 • G HIGH
 • B HIGH
 • R LOW
 • G LOW
 • B LOW

INPUT 4 (COMPONENT)
 480i (15k/60Hz)
 480p (31k/60Hz)
 720p
 1080i
 1080p
 15k/50Hz
 31k/50Hz

• CONTRAST
 • BRIGHT
 • COLOR
 • TINT
 • SHARP
IN4-480i COMPONENT

• CONTRAST
 • BRIGHT
 • COLOR
 • TINT
 • H. SHARP
 • V. SHARP
 • R HIGH
 • G HIGH
 • B HIGH
 • R LOW
 • G LOW
 • B LOW

INPUT 4 (RGB)
 480i (15k/60Hz)
 480p (31k/60Hz)
 720p
 1080i
 1080p
 15k/50Hz
 31k/50Hz

• CONTRAST
 • BRIGHT
 • COLOR
 • TINT
 • SHARP
IN4-480i RGB

• CONTRAST
 • BRIGHT
 • COLOR
 • TINT
 • H. SHARP
 • V. SHARP
 • R HIGH
 • G HIGH
 • B HIGH
 • R LOW
 • G LOW
 • B LOW

INPUT 4 (PC RGB)
 PC-#5
 PC-#6
 PC-#7
 PC-#8
 IN4-TEMPORARY

• CONTRAST
 • BRIGHT
 • R LEVEL
 • G LEVEL
 • B LEVEL
IN4-PC#5

• CONTRAST
 • BRIGHT
 • R HIGH
 • G HIGH
 • B HIGH
 • R LOW
 • G LOW
 • B LOW

Menu Mode

Integrator Mode

Integrator Mode

5.4.6 SCREEN adjustment values area tables

The SCREEN adjustment values memory area is laid out as shown below. When a function like the DEFAULT function is executed, items return to their center values. When INPUTS 1 and 2 are selected, SCREEN adjustment in menu mode becomes impossible.

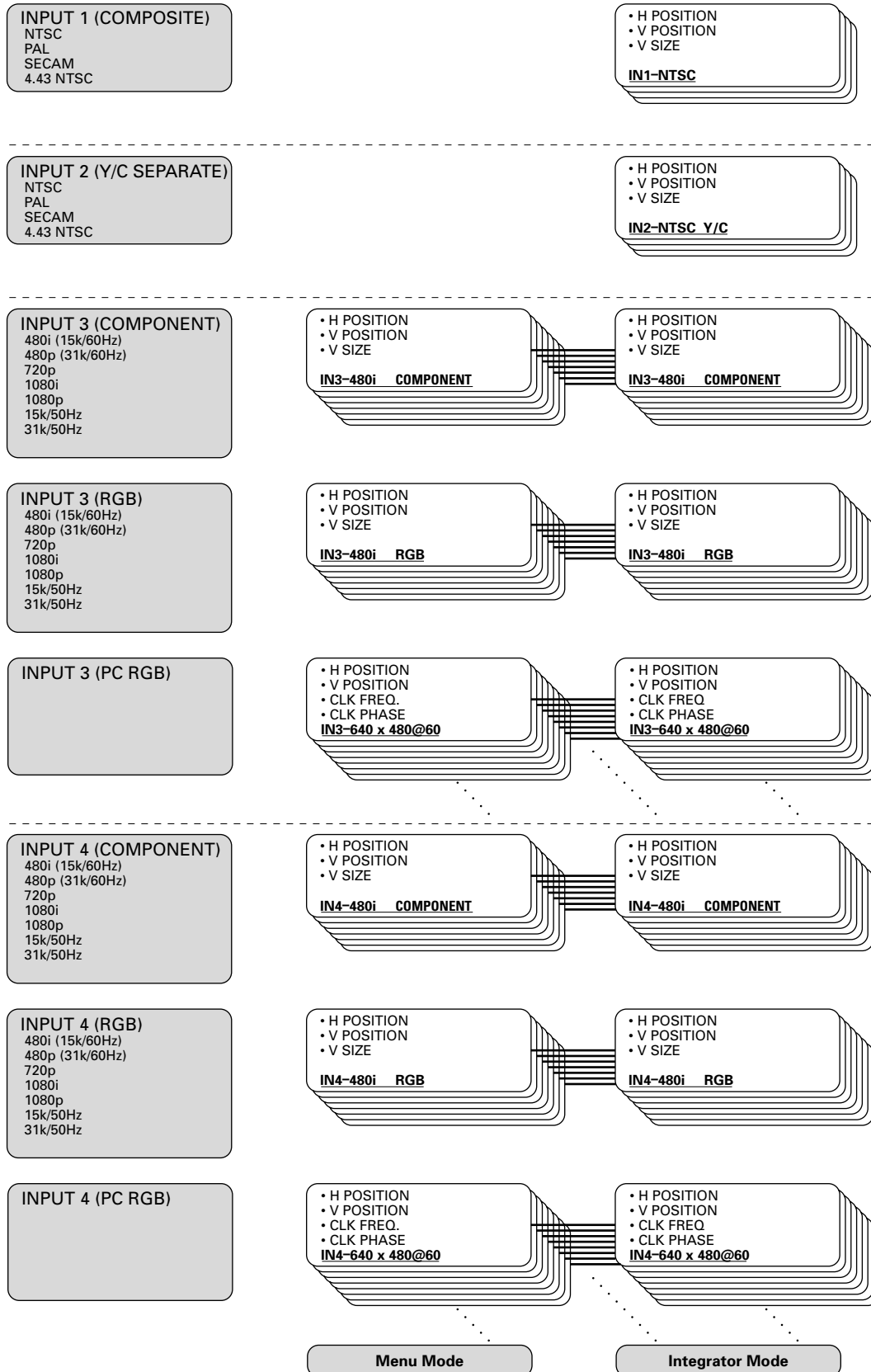

5.5 RS-232C Adjustment Mode

Through the unit's RS-232C terminal. You can use a PC to make various adjustments and settings.

5.5.1 About the RS-232C adjustment mode

- 1) When carrying out adjustments in the RS-232C adjustment mode
 - The data is written into the same memory area as for integrator mode (refer to 5.4.5 and 5.4.6 'Memory area tables').

(NOTE) Adjustments affect only the input selected.

- 2) Screens displayed in the RS-232C Adjustment Mode
 - The display will appear much like the illustration to the right. The ID number of the set of adjustments will be indicated in the upper left corner of the screen, where "--" is shown in the illustration. A display such as "0C-1" in the upper right of the screen is for factory adjustments.

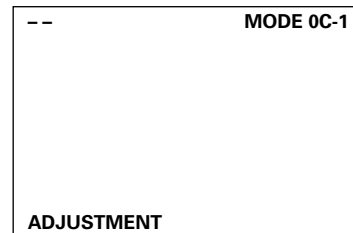

CAUTION

- (1) Always enter ID before using RS-232C adjustment mode. In addition, include the ID of the set to be targeted for control/adjustment in the RS-232C command that you transmit. Refer to section 5.5.2, "Interface".
- (2) The adjustments are stored in last memory using <AJN>. When you have finished making the adjustments, make sure that you execute <AJN>. When changing the type of signal that will be the target of the adjustments (e.g. when changing from NTSC to PAL or changing the PC refresh rate), make sure that you execute <AJN> before switching over the type of signal and then once again execute <AJY>.
- (3) Some RS-232C commands can be used in normal operating mode. Refer to section 5.5.4, "List of RS-232C commands".
- (4) With the exception of the following cases, the adjustment data and set items from RS-232C adjustment mode are all stored in last memory. A precondition for this however is that all of the conditions in "5.1.5 Last memory" have been satisfied. Cases where the adjustment data and set items are not stored in last memory. For the following commands in normal operating mode:
 - <IN 1-4> (input switching)
 - <MMN. X. Y. Z> (mirror mode switching)
 - <AMY. N> (muting)
 - <AJY> (transition to RS-232C adjustment mode)

For the following command in RS-232C adjustment mode

 - <DOF> (OSD display OFF)

Please take due care.
- (5) About <DIN>/<DIY> (OSD displays disabled/enabled) No matter what the settings, the following items may be displayed.
 - Menu display (Menu mode, integrator mode, and RS-232C adjustment mode)
 - Warning just before the Power Save feature comes on
 - Warning of high internal temperature ("THERMAL WARNING! PLEASE SHUT DOWN")
 - Display announcing KEY LOCK is set; also display announcing the setting of KEY LOCK/UNLOCK
- (6) RS-232C adjustment mode is automatically canceled when the STANDBY/ON, MENU, or KEY LOCK/UNLOCK (main unit operating panel only) are pushed.

RS-232C Adjustment Mode

5.5.2 Interface

- 1) Connector
D-sub 9 pins
- 2) Pin layout

(NOTE) Plasma is a DCE device.

Pin No.	Signal
1	NC (not connected)
2	TxD (Transmit Data)
3	RxD (Receive Data)
4	NC (not connected)
5	GND
6	NC (not connected)
7	NC (not connected)
8	RTS (Request To Send)
9	NC (not connected)

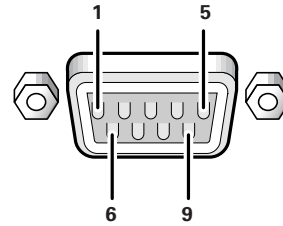

- 3) Baud Rate
4800 bps (standard)
(switch-able to 1200, 2400, 9600, 19200 bps)
(NOTE) Set the baud rate to match that of the computer presently in use. Moreover, in the case that the RS-232C cable is very long, we recommend that you make the baud rate lower.
- 4) Data Format
Start: 1-bit
Data: 8-bit
Parity: 0 (no parity)
Stop: 1-bit

5) Connection

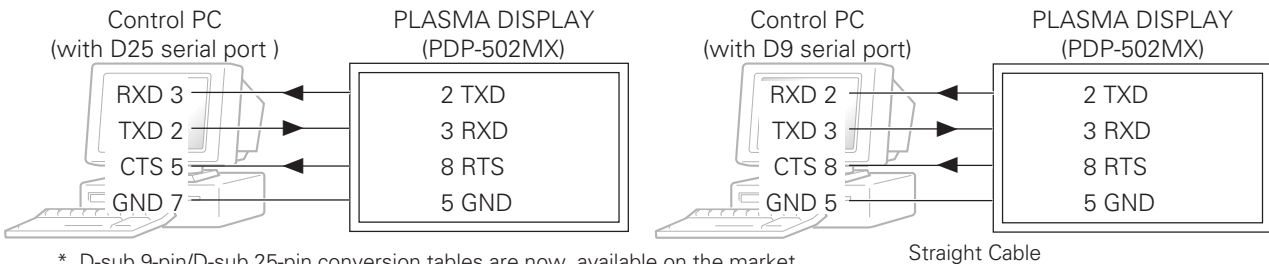

* D-sub 9-pin/D-sub 25-pin conversion tables are now available on the market.

(NOTE) As computer manufactures may not use the same pin assignments. In case of communication difficulties, please check pin functions not just pin numbers.

6) Protocol

From computer to plasma display

(1) When transmitting commands individually

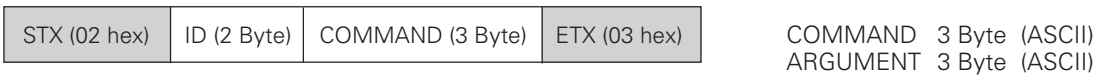

(2) When transmitting commands in batches (up to max. 3 commands) (NOTE)



(3) When transmitting direct numeric commands



- (NOTE)
- Transmit <PON> and <POF> commands one by one. (Allow an interval of three or more seconds between commands.)
 - Transmit an input switching command (IN 1-4) and <AJY> command, allowing sufficient time between them.
 - Allow an interval of approximately Four or more seconds between input switching commands (IN 1-4).

Error Example 1)

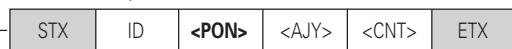

Error Example 2)



Error Example 3)

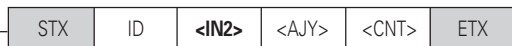

5.5.3 ID assignment

When a connection is made, this feature assigns an ID. ID assignment is performed in the PC.

Commands: <IDC> (ID CLEAR) Clears assigned IDs.
<IDS> (ID SET) Assigns IDs
IDS is only effective when an ID has not been assigned.
It is assigned from a unit close to the PC.

Example: 4 units (At first, the ID is assigned at the PC.)

First of all, following the example in the diagram below, carry out the RS-232C connection and the combination connection (see "5.6 Combination connection").

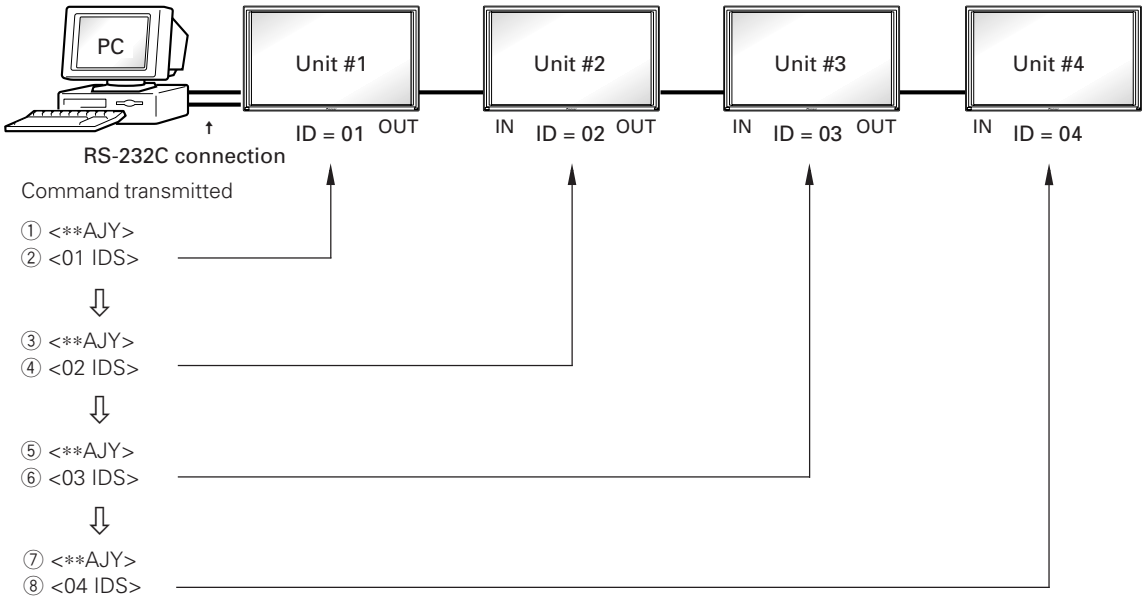

By sending RS-232C commands in this order, you can assign an ID to each set. A unit to which an ID has been assigned can only receive commands which have that ID attached. Attach ID to the beginning of commands before transmitting them.

Characters that may be used when assigning IDs are 0~9 and A~F (there is no differentiation between uppercase and lowercase letters).

- <IDC> : Clear assigned ID of all units.
<*1AJY> : Units with 1 as the second digit in their ID will go into adjustment mode.
<2*IN1> : Units with 2 as their first digit will use INPUT 1.

Cautionary notes regarding ID assignment

Units connected to other units from which IDs were cleared will become inoperable by RS-232C.

After making settings as in the diagram above, if you carry out <AJY> -> <IDC> then the IDs will be cleared for all of the sets #1~#4, and it will become such that you can only control the set connected directly to the PC (set #1). If you then carry out <AJY> -> <01 IDS>, it will become such that you can only control the second set (set #2). By setting ID likewise thereafter, the setting of subsequent units will become operable.

RS-232 Adjustment Mode

5.5.4 List of RS-232C commands

How to read this table

- Normal validity : Shows availability in the normal operating mode.
Commands shown as valid are so whether or not preceded by an <AJY> command.
- Direct validity : Shows commands that, if transmitted followed by numerical values, can or cannot directly set the corresponding items to those values sent out.
- Up/Down validity : Shows commands that, if transmitted followed by UPn/DWn (n standing for any numbers from 0 to 9), can or cannot increase or decrease the corresponding current adjustments by those numbers.

(NOTE) With regard to the propriety of last memory, please refer to "5.5.1 About the RS-232C adjustment mode".

○ or ● : Yes × : No

(NOTE) ● = Not put into last memory

	Command Name	Full Name	Normal Validity	Direct Validity	Up/Down Validity	Function
A	ABN	ABL NO	×	×	×	Sets ABL to OFF.
	ABY	ABL YES	×	×	×	Sets ABL to ON.
	AJN	ADJUST NO	×	×	×	Terminates RS-232C adjustment mode.
	AJY	ADJUST YES	●	×	×	Initiates RS-232C adjustment mode.
	AMN	AUDIO MUTE NO	●	×	×	Turns audio mute OFF.
	AMY	AUDIO MUTE YES	●	×	×	Turns audio mute ON.
B	BBY	VIDEO RGB YES	×	×	×	Sets INPUT to VIDEO: RGB.
	BRT	BRIGHTNESS	×	○	○	Adjusts BRIGHTNESS.
	BHI	BLUE HIGH	×	○	○	Adjusts BLUE HIGH-LIGHT.
	BLW	BLUE LOW	×	○	○	Adjusts BLUE LOW-LIGHT.
	BSL	BLUE SIDE MASK LEVEL	×	○	○	Adjusts BLUE SIDE MASK LEVEL.
	BR1	BAUD RATE 1	×	×	×	Sets RS-232C baud rate to 1200 bps.
	BR2	BAUD RATE 2	×	×	×	Sets RS-232C baud rate to 2400 bps.
	BR3	BAUD RATE 3	×	×	×	Sets RS-232C baud rate to 4800 bps.
	BR4	BAUD RATE 4	×	×	×	Sets RS-232C baud rate to 9600 bps.
BR5	BAUD RATE 5	×	×	×	Sets RS-232C baud rate to 19200bps.	
C	CFR	CLOCK FREQUENCY	×	○	○	Adjusts clock frequency.
	CL1	CLAMP MODE 1	×	×	×	Sets Clamp Position Setting Mode to 1.
	CL2	CLAMP MODE 2	×	×	×	Sets Clamp Position Setting Mode to 2.
	CM1	COLOR MODE 1	○	×	×	Sets White Balance Adjustment Data to Mode 1.
	CM2	COLOR MODE 2	○	×	×	Sets White Balance Adjustment Data to Mode 2 (retake).
	CNT	CONTRAST	×	○	○	Adjusts CONTRAST.
	COL	COLOR	×	○	○	Adjusts COLOR.
	CP1	VIDEO COMPONENT-1 YES	×	×	×	Sets INPUT to VIDEO: COMPONENT 1.
	CP2	VIDEO COMPONENT-2 YES	×	×	×	Sets INPUT to VIDEO: COMPONENT 2.
	CPH	CLOCK PHASE	×	○	○	Adjusts clock phase.
D	DIN	OSD DISPLAY NO	×	×	×	Disables OSD displays.
	DIY	OSD DISPLAY YES	×	×	×	Enables OSD displays.
	DOF	DISPLAY OFF	×	×	×	Turns OSD display OFF.
	DSP	INPUT SIGNAL DISPLAY	×	—	—	Displays the current input signal information
	DW0	DOWN 10	×	×	×	Decreases adjustment values by 10.
	DWn	DOWN n	×	—	—	Decreases adjustment values by n.
	DWF	DOWN FULL	×	—	—	Decreases adjustment values to minimum.
F	FCA	FAN CONTROL AUTO	×	×	×	Makes control of fan's rotation automatic.
	FCM	FAN CONTROL MAX	×	×	×	Makes control of fan's rotation FIXED (MAX).
	FMB	FULL MASK BLUE	×	×	×	Turns full mask blue ON
	FMG	FULL MASK GREEN	×	×	×	Turns full mask green ON
	FMN	FULL MASK NO	×	×	×	Turns full mask OFF
	FMR	FULL MASK RED	×	×	×	Turns full mask red ON
	FMY	FULL MASK YES	×	×	×	Turns full mask white ON
	FRP	FRESH POSITION	×	×	×	Centers the SCREEN adjustment data
	FRW	FRESH WHITE BALANCE	×	×	×	Sets picture quality and white balance adjustment data to median values.
G	GHI	GREEN HIGH	×	○	○	Adjusts GREEN HIGH-LIGHT.
	GLW	GREEN LOW	×	○	○	Adjusts GREEN LOW-LIGHT.
	GPS	GET POSITION DATA	×	×	×	Sends out position adjustment data in TxD.
	GSL	GREEN SIDE MASK LEVEL	×	○	○	Adjusts GREEN SIDE MASK LEVEL.
	GST	GET STATUS	×	×	×	Sends out various adjustment data in TxD.
	GS2	GET STATUS 2	×	×	×	Sends out various settings status data. in TxD.
	GWB	GET W/B DATA	×	×	×	Sends out picture quality and white balance adjustment data in TxD.

RS-232C Adjustment Mode

	Command Name	Full Name	Normal Validity	Direct Validity	Up/Down Validity	Function
H	HCN	HIGH CONTRAST NO	×	×	×	Turns the HIGH CONTRAST setting OFF. Turns the HIGH CONTRAST setting ON. Lets hour meter appear. Adjusts horizontal position.
	HCY	HIGH CONTRAST YES	×	×	×	
	HMD	HOURLY METER DISPLAY	×	×	×	
	HPS	HORIZONTAL POSITION	×	○	○	
I	IDC	ID CLEAR	×	×	×	Clears ID. Sets ID. Selects INPUT 1 (RCA or BNC). Selects INPUT 2 (S-terminal or Y/C). Selects INPUT 3 (BNC x 5). Selects INPUT 4 (mini D-sub 15).
	IDS	ID SET	×	×	×	
	IN1	INPUT1	●	×	×	
	IN2	INPUT2	●	×	×	
	IN3	INPUT3	●	×	×	
K	KLN	KEY LOCK NO	×	×	×	Enables controls on display/remote. Disables controls on display/remote.
	KLY	KEY LOCK YES	×	×	×	
M	MMN	MIRROR MODE NO	●	×	×	Resets mirror mode setting. (normal use) Sets mirror mode to X (left/right reverse). Sets mirror mode to Y (up/down reverse). Sets mirror mode to XY (up/down & left/right reverse).
	MMX	MIRROR MODE X	●	×	×	
	MMY	MIRROR MODE Y	●	×	×	
	MMZ	MIRROR MODE XY	●	×	×	
N	NT4	TV SYSTEM 4.43 NTSC	×	×	×	Sets COLOR SYSTEM to 4.43 NTSC. Sets COLOR SYSTEM to NTSC.
	NTS	TV SYSTEM NTSC	×	×	×	
P	PAL	TV SYSTEM PAL	×	×	×	Sets COLOR SYSTEM to PAL. Sets INPUT to PC: RGB. Turns off power. Turns on power. Turns off central screen brightness correction. Turns on central screen brightness control. Sets power save off. Sets power save to Mode 1. Sets power save to Mode 2.
	PCY	PC RGB YES	×	×	×	
	POF	POWER OFF	○	×	×	
	PON	POWER ON	○	×	×	
	PLN	BRIGHT ENHANCE OFF	×	×	×	
	PLY	BRIGHT ENHANCE ON	×	×	×	
	PSN	POWER SAVE OFF	×	×	×	
	PS1	POWER SAVE MODE 1	×	×	×	
	PS2	POWER SAVE MODE 2	×	×	×	
R	RHI	RED HIGH	×	○	○	Adjusts RED HIGH-LIGHT. Adjusts RED LOW-LIGHT. Adjusts RED SIDE MASK LEVEL.
	RLW	RED LOW	×	○	○	
	RSL	RED SIDE MASK LEVEL	×	○	○	
S	SCM	TV SYSTEM SECAM	×	×	×	Sets COLOR SYSTEM to SECAM. Adjusts H. SHARPNESS. Adjusts V. SHARPNESS. Sets screen size to original. Sets screen size to 4:43 Normal. Sets screen size to full. Sets screen size to Zoom. Sets screen size to Cinema Wide. Sets screen size to Natural Wide. Resets picture quality and white balance adjustment data to defaults. Adjusts SUB VOLUME of INPUT 1. Adjusts SUB VOLUME of INPUT 2. Adjusts SUB VOLUME of INPUT 3. Adjusts SUB VOLUME of INPUT 4.
	SHP	H. SHARPNESS	×	○	○	
	SHV	V. SHARPNESS	×	○	○	
	SM0	SCREEN MODE 0	○	×	×	
	SM1	SCREEN MODE 1	○	×	×	
	SM2	SCREEN MODE 2	○	×	×	
	SM3	SCREEN MODE 3	○	×	×	
	SM4	SCREEN MODE 4	○	×	×	
	SM5	SCREEN MODE 5	○	×	×	
	STD	STD.WHITE BALANCE DATA	×	×	×	
	SV1	SUB VOLUME INPUT1	×	○	○	
	SV2	SUB VOLUME INPUT2	×	○	○	
	SV3	SUB VOLUME INPUT3	×	○	○	
SV4	SUB VOLUME INPUT4	×	○	○		
T	TNT	TINT	×	○	○	Adjusts TINT. Sets COLOR SYSTEM to AUTO.
	TVA	TV SYSTEM AUTO	×	×	×	
U	UP0	UP10	×	—	—	Increase adjustment values by 10. Increases adjustment values by 10. Increases adjustment values to maximum.
	UPn	UP n	×	—	—	
	UPF	UP FULL	×	—	—	
V	VOL	VOLUME	×	○	○	Adjusts volume. Adjusts vertical position. Adjusts vertical size.
	VPS	VERTICAL POSITION	×	○	○	
	VSI	VERTICAL SIZE	×	○	○	
Y	YCM	3D Y/C MOTION	×	×	×	Sets motion mode to MOTION. Sets motion mode to STILL.
	YCS	3D Y/C STILL	×	×	×	

(NOTE) Make sure that you use the SUB VOLUME adjustment commands <SV1~4> only after switching to the required input using the appropriate input switching command <IN1~4>.

RS-232C Adjustment Mode

5.5.5 About the GET commands

What are GET commands?

- These are commands used to transmit adjustment data and other information in TXD to PCs from a microcomputer inside the plasma display.
- This information is transmitted in ASCII code.

(NOTE) Command names are given inside < >.

1) <GPS> (GET POSITION DATA) – SCREEN parameters are issued in the following formats.

STX (02 hex)	H.POSITION (3 Byte)	V.POSITION (3 Byte)	DUMMY DATA (3 Byte)	V.SIZE (3 Byte)...(NOTE)	CLK FREQ. (3 Byte)...(NOTE)	CLK PHASE (3 Byte)...(NOTE)	ETX (03 hex)
-----------------	------------------------	------------------------	------------------------	-----------------------------	--------------------------------	--------------------------------	-----------------

- (NOTE)
- If the present input signal is a video input signal, the adjustment data of CLK FREQ. and CLK PHASE will be output as dummy data.
 - If the present input signal is a PC input signal, the adjustment data of V.SIZE will be output as dummy data.
 - If the present input signal is "1280 × 1024/60 Hz", the SCREEN adjustment data of present display screen size will be output.

2) <GWB> (GET W/B DATA) – PICTURE and WHITE BALANCE parameters are issued in the following formats:

STX (02 hex)	CONTRAST (3 Byte)	BRIGHT (3 Byte)	RED HIGH (3 Byte)	GREEN HIGH (3 Byte)	
	BLUE HIGH (3 Byte)	RED LOW (3 Byte)	GREEN LOW (3 Byte)	BLUE LOW (3 Byte)	
	COLOR (3 Byte)...(NOTE)	TINT (3 Byte)...(NOTE)	H. SHARP (3 Byte)...(NOTE)	V. SHARP (3 Byte)...(NOTE)	
	DUMMY DATA (3 Byte)	DUMMY DATA (3 Byte)	DUMMY DATA (3 Byte)	DUMMY DATA (3 Byte)	ETX (03 hex)

- (NOTE) If the present input is PC input, the adjustment data of COLOR, TINT, H. SHARP, and V. SHARP will be output as dummy data.

3) <GST> (GET STATUS) – The status of various settings is transmitted in the following formats:

STX (02 hex)	PC SOFTWARE VERSION (5 Byte)	INPUT FUNCTION (3 Byte)	COLOR MODE (3 Byte)	SCREEN SIZE (3 Byte)	POWER SAVE (3 Byte) ①	
	DUMMY DATA (3 Byte)	COLOR SYSTEM (3 Byte) ②	3D Y/C (3 Byte) ③	HIGH CONTRAST (3 Byte)	INPUT SETTING (3 Byte) ④	
	CLAMP (3 Byte) ④	ABL (3 Byte) ④	DUMMY DATA (3 Byte)	KEY LOCK (3 Byte)	OSD DISPLAY (3 Byte)	
	MIRROR MODE (3 Byte)	CENTRAL SCREEN BRIGHTNESS (3 Byte) ①	FAN CONTROL FORMAT (3 Byte)	EASY TEMPERATURE MEASUREMENT (3 Byte)	ACCUMULATED ON TIME (5 Byte)	ETX (03 hex)

- (NOTE) • Items not related to the ongoing INPUT functions/INPUT signals will output dummy data.
- ① Depending on the present signal input (video or PC signal) the output content will switch.
 - ② Dummy data will be output unless in INPUT 1 or 2.
 - ③ Dummy data will be output unless in INPUT 1.
 - ④ Dummy data will be output unless in INPUT 3 or 4.
- For more information concerning output, refer to section 5.5.4, "List of RS-232C Commands".

Temperature TxD output value (3 bytes)	300	340	380	420	450	XXX
Outside air temperature (°C) (see note)	to 30.0	to 34.0	to 38.0	to 42.0	to 45.0	45.0 or more

(NOTE): The term 'outside air temperature' as it is used here is meant to serve as a rough guideline for when the unit has been installed so as to allow the free flow of air around the unit, and this term is therefore to be distinguished from the term 'ambient temperature' as used in 3 "Installation". Note that there may be times when errors occur in temperature readings. Also note that it is particularly important to be sure to check the ambient temperature when the unit has been installed as described in 3.4 "Special Installation" to ensure that all installation requirements have been satisfied.

4) GS2 (GET STATUS 2) - Outputs the state of the various settings in the format shown below.

STX (02 hex)	SUB VOLUME INPUT 1 (3 Byte)	SUB VOLUME INPUT 2 (3 Byte)	SUB VOLUME INPUT 3 (3 Byte)	SUB VOLUME INPUT 4 (3 Byte)	R SIDE MASK (3 Byte)	
	G SIDE MASK (3 Byte)	B SIDE MASK (3 Byte)	DUMMY DATA (3 Byte)	DUMMY DATA (3 Byte)	DUMMY DATA (3 Byte)	ETX (03 hex)

Combination Connection

5.6 Combination Connection

This is useful for controlling/adjusting a number of sets from a single PC.

By carrying out combination connection and then assigning IDs to each of the sets, it becomes possible to control/adjust a number of sets either all at once or individually.

5.6.1 Connections

Carry out connections as shown below. You can then control/adjust the units from the PC.

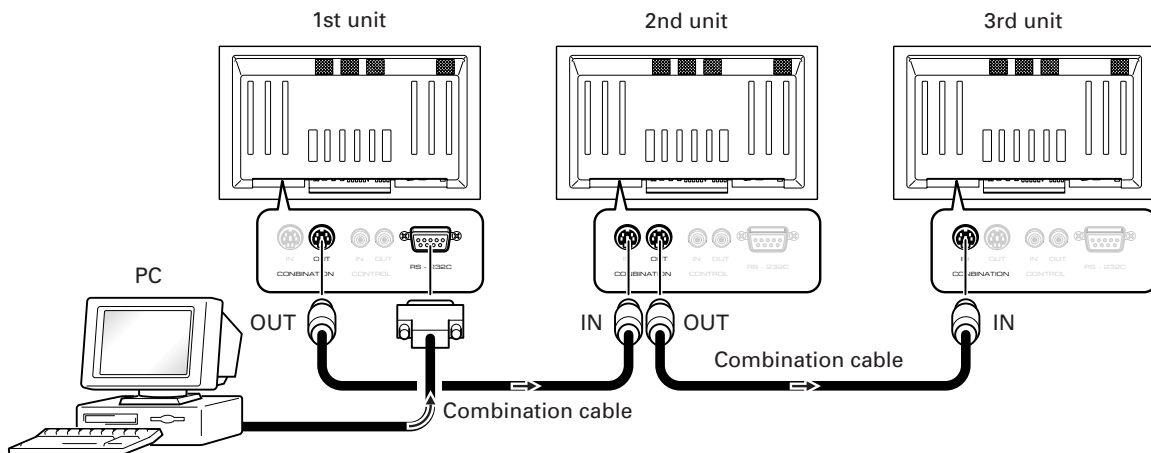

NOTE

You may use either combination input or control port RS-232C connector, but not both at once. Using both simultaneously will result in malfunction or system breakdown.
 Don't connect combination inputs to other combination inputs, or combination outputs to other combination outputs. It may cause a trouble.

General purpose Mini Din 6-pin (straight) cables may be used as combination cables.

The connections for remote control signals are as shown below.

- The order of precedence for remote control signals is as follows:
 - Control IN terminal (SR IN) >
 - Combination IN terminal >
 - Remote control infra-red receiver
 Example: If you connect a cable to the Control IN terminal (SR IN) then the built-in Control IN terminal (SR IN) switch makes it impossible to receive remote control signals via either the remote control infra-red receiver (??) or the Combination IN terminal.
 (NOTE) RS-232C signals can still be received via the Combination IN terminal.

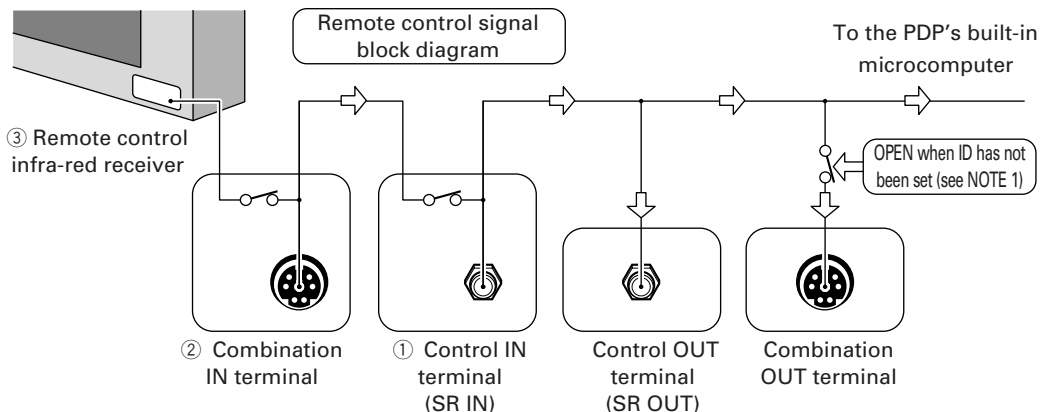

NOTE 1) In order to output remote control signals or RS-232C signals from the Combination OUT terminal, it is necessary to assign an ID. For more details see "5.5.3 ID Assignment".

NOTE 2) With the Combination IN/OUT terminals, remote control signals and RS-232C signals are inputted/outputted simultaneously. For more details see "2.3 Controls and Connectors".

Combination Connection

If the following connection conditions are observed, extension of operations to as many as 16 units is guaranteed.

- Conditions:
- ① Length of RS-232C cable connecting PC to PDP-502MX: 5 m
 - ② Combination cable length: 5 m for each
 - ③ Wire specifications for linking cable: Mini Din 6-pin straight (7 strand cable)

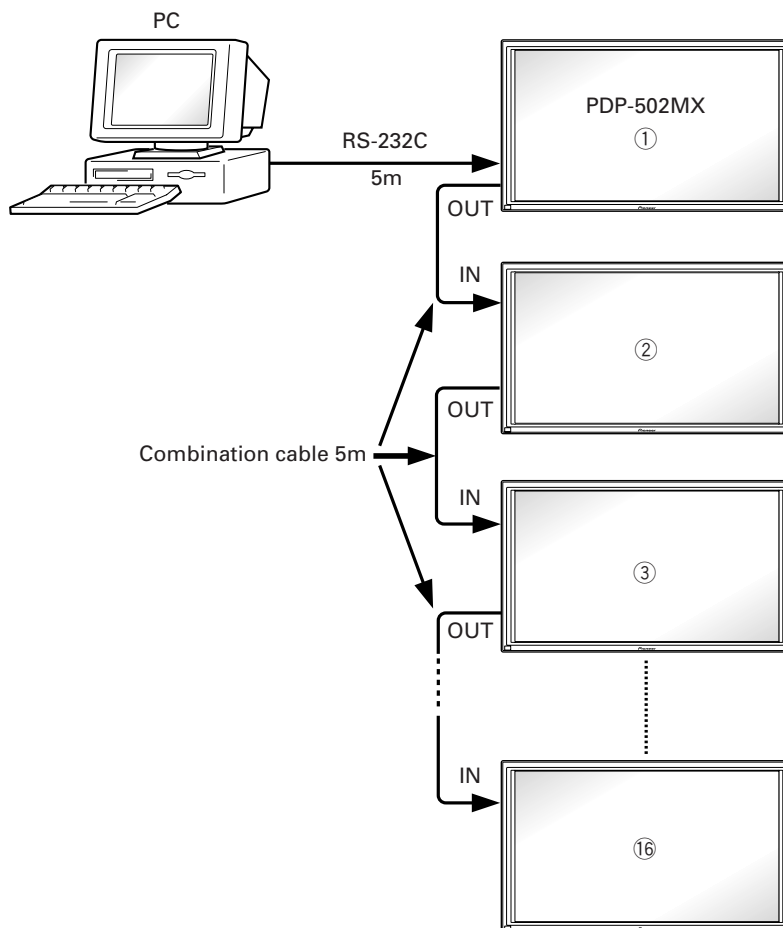
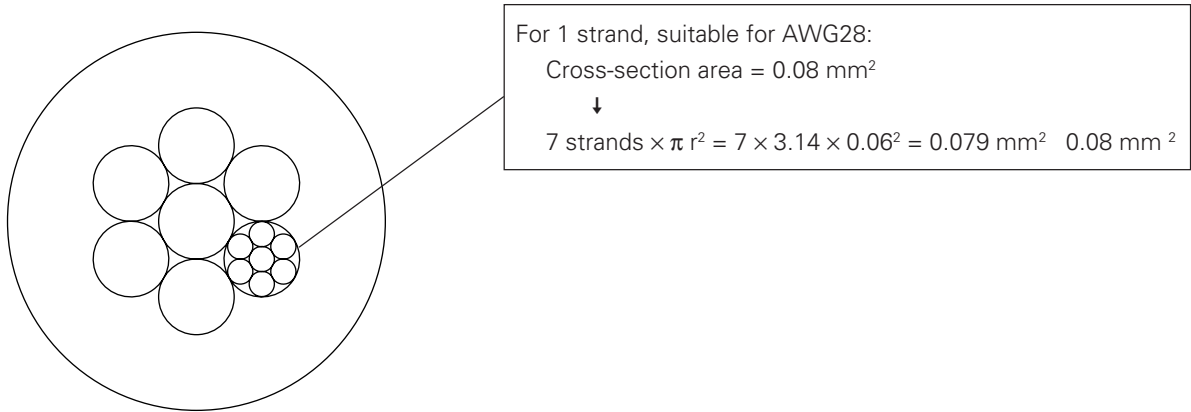

(NOTE) Refer to section 2.3, "Controls and Connectors" regarding the number of units that can be connected when series connection is made while using a video output terminal (INPUT 1 or 4).

KEY LOCK/UNLOCK

5.7 KEY LOCK/UNLOCK

5.7.1 Functions

The KEY LOCK function disables the remote control unit and the main unit operation panel, preventing unauthorized persons from tampering with the unit after installation (RS-232C commands remain effective). Attempting to operate the remote control unit or the main unit operation panel will cause "KEY LOCK" to be displayed in the upper right corner of the screen. The unit is factory preset to KEY UNLOCK, meaning that the remote control unit and main unit operation panel are both enabled.

5.7.2 How to switch KEY LOCK/UNLOCK

Two settings methods are available:

- 1) With the operating panel of the main unit (A hidden button is provided for this purpose.)

Change the setting between KEY LOCK and KEY UNLOCK using the KEY LOCK/UNLOCK button hidden between the STANDBY/ON and INPUT buttons. Pressing the KEY LOCK/UNLOCK button while in menu mode or integrator mode automatically places the unit in normal operating mode and at the same time invokes the KEY LOCK status.

- 2) Using RS-232C Commands

Issue the <AJY> command to enter RS-232C adjustment mode. Then issue the <KLY> command to invoke KEY LOCK or the <KLN> command to invoke KEY UNLOCK.

Regarding the problem of images becoming burnt onto the screen

5.8 Regarding the problem of images becoming burnt onto the screen

If the same image is shown on the screen for a prolonged period of time (i.e. a still picture or a closed-captioning etc.), then this image may become permanently burnt onto the screen. This problem can be managed by changing image composition, source rotation or other methods. Additionally, this unit also offers the following methods of reducing the likelihood of images from becoming burnt onto the screen.

① Movement of the picture border

Every time you turn the unit on, the built-in microcomputer moves the picture border randomly.

NOTE: This only applies when there is a side mask, for example with the 4:3 screen size.

② Automatic brightness adjustment (detection of still pictures)

This function detects pictures that have little or no movement and automatically adjusts the brightness. (This function operates only in normal operating mode and menu mode.)

③ Side mask adjustment

Side mask adjustment may be used to adjust the brightness of the area around the periphery of the display in which no picture is displayed when displaying images at 4:3 size or other reduced sizes, thus helping to prevent the burning of side mask border lines into the screen caused by differences in the brightness of displayed images and the side mask area. (Please refer to "5.4.3.4 Adjusting the side mask".)

Adjustment is also possible using RS-232C commands (please refer to "5.5.4 List of RS-232C commands").

④ Full mask (Full Screen Color Wash) setting

This function turns the entire screen a single color - white, red, green or blue - using a PDP internal signal (please refer to "5.4.3.10 Setting FULL MASK").

Setting is also possible using RS-232C commands (please refer to "5.5.4 List of RS-232C commands").

In the case that an image has been burnt onto the screen, FULL MASK can be used as an emergency measure to reduce the symptoms (although it will be impossible to completely remove the burnt-on image).

In addition, proper 'aging' of the screen through use of FULL MASK in advance will make the screen less prone to the problem of images becoming burnt onto it.

Operating Precautions and recommendations

6.1 Operating Precautions and recommendations

- 1) If the display shuts down on its own and will not power up again, please try the followings.
Turn off the main power switch for the plasma display, wait 10 seconds and power it on again.
If the display shuts down, there may be a internal problem, Consult with Pioneer Authorized Service Center.
If it remains powered up, you may continue using it.

- 2) If the same image is shown on the screen for a prolouged period of time (i.e. a still picture or a closed-captioning, etc.), then this image may become permanently burnt onto the screen.
This ploblem can be managed by changing image composition, source rotation or other methods.
(NOTE) Please see section "5.8 Regarding the problem of images becoming burnt onto the screen" for details.

- 3) The following signals cause inferior image quality:
 - Multifold-generation video sources copy of VTR signals
 - Copyright protected signals
 - Scrambled CATV signals
 - Signals with significantly phase-shifted sync and video signals

- 4) Images are blacked out for approximately one to three seconds when input is switched, to permit the plasma display driver to temporarily suspend operation while video memory is refreshed. When you switch input between different frequencies, a longer black-out interval is needed (up to approximately three seconds) due to the array of data to be changed in video memory. Allow for this interval when "staging" video.

- 5) The fan will begin spinning faster when ambient temperature rises above 30 °C. This is normal.

- 6) About the plasma panel's screen-saver feature (Direction of still images)
Brightness will drop slightly when photo images or slow-moving images, such as those supplied by a PC, are shown for extended periods. The unit detects the lack of motion, and automatically dims the screen brightness to protect the plasma display panel. This is normal and does not indicate a problem.
 - The feature generally kicks in approximately five minutes after powering-up or switching input in normal operating mode/menu mode. This feature does not function in RS-232C adjustment mode <AJY> or in integrator mode.

Maintenance and Cleaning

1) Unplug the power cord from the outlet.

2) Cabinet and remote control unit

Never use solvents such as benzene or thinner, which can damage or destroy the coating on the cabinet or the remote control unit.

Remove dirt by lightly wiping with a soft cloth.

If necessary, slightly moisten the cloth with neutral detergent, diluted with water. In humid conditions, wipe off condensation with a dry cloth.

3) Screen (front protection panel)

The screen surface (front protection panel) is coated with a delicate anti-glare material. To clean the screen dust off and wipe lightly with a soft cloth. Do not rub with tissue paper or hard abrasive materials.

Never use solvents such as benzene or thinner, which can discolor the screen or render it opaque.

For cleaning, we recommend the following cloth and fluid.

Name	Part Number
Cleaning cloth, wiping cloth	AED1174
Cleaning cloth: Minimax	GED-009
Cleaning liquid: B4	GEM1004

For light soiling, brush off dust and lightly wipe with Minimax. In case of heavy soiling, brush off dust, then wipe with Minimax with its corner lightly moistened with B4. Be sure to wipe with dry Minimax after B4 dries out as there may be unevenness remaining otherwise.

4) Vents

Every month, remove dirt from the vent openings that house fans on the sides and rear of the main unit, using a vacuum cleaner set to its lowest suction setting. Be sure to switch off the power on the main unit before cleaning the vents.

Blocked vents can lead to dangerously high internal temperatures, resulting in malfunctions or fire.

5) Readjustment of White Balance

The unit uses phosphor elements, as do CRTs. These phosphors degrade over time, reducing brightness. Since green and blue phosphors degrade faster than red, we recommend readjusting the white balance every 1000 hours.

Free Manuals Download Website

<http://myh66.com>

<http://usermanuals.us>

<http://www.somanuals.com>

<http://www.4manuals.cc>

<http://www.manual-lib.com>

<http://www.404manual.com>

<http://www.luxmanual.com>

<http://aubethermostatmanual.com>

Golf course search by state

<http://golfingnear.com>

Email search by domain

<http://emailbydomain.com>

Auto manuals search

<http://auto.somanuals.com>

TV manuals search

<http://tv.somanuals.com>