

TECHNICAL MANUAL (Ver.1.0)

MULTI PROJECTION UNIT

RM-V2400NA / V2500NA
RM-V2400NE / V2500NE

PROJECTION SCREEN KIT

RMS-V4011/V5011

PROJECTION FRAME

RMF-V4011/V5011

PROJECTION CABINET

RMF-V4011R/V4011CR

 **Caution**

This symbol refers to a hazard or unsafe practice which can result in personal injury or property damage.

Notes:

- Pioneer will not be liable for any loss caused by defects of the parts supplied other than by Pioneer.
- An damage during shipping will be compensated for only in the case where Pioneer's specific packing materials for shipping are used.
- The guarantee of performance is applicable only when the assembly and adjustment described in this technical manual and the adjustment described by the system manual of RM-V2000 have been carried out.
- Specifications and design subject to possible modification without notice, due to improvements.

PIONEER RM-V2400 / 2500 MANUAL.

This Acrobat (IE: a PDF file) version of the Pioneer RM-V2400 / 2500 manual was made from the original digital document and scanning an existing manual. Because of this, there are many less than perfect pages and hand written comments.

As Pioneer is constantly working towards providing the best possible documentation for our products, there may be an improved version of this document available. Please contact your Pioneer representative for additional information.

Josh Kairoff
Pioneer New Media Technology.
October 27, 1997.

CONTENTS

CHAPTER 1. FEATURES OF PROJECTION CUBE SYSTEM	4
1. FEATURES OF SYSTEM	4
2. FEATURES OF MULTI PROJECTION UNIT (RM-V2400N/V2500N)	4
3. FEATURES OF FRAME TYPE	5
4. FEATURES OF CABINET TYPE	5
CHAPTER 2 . GENERAL SPECIFICATIONS	6
1. SPECIFICATIONS	6
(1) Multi Projection Unit (RM-V2400N/V2500N)	6
(2) Projection Screen Kit(RMS-V4011/V5011)Product Weight:11.0kg/14.0kg	13
(3) Projection Frame (RMF-V4011/V5011)Product Weight:26.8kg/28.8kg	14
(4) Projection Cabinet(RMF-V4011R/V4011CR)	15
(5) Projection Install Table (RM-V112/RMA-V5010)	17
(6) Munting Unit (RMA-V2050/2060)	18
(7) Multi Video Processor(RMD-V3216/3109,RMD-V2170)	19
(8) Adjustment Control Unit (RU-V107)*Option	21
(9) Projection Cabinet (RMF-V4011R) Accessories	22
2. SYSTEM DIMENSIONS	23
(1) 160-inch (40-inch 4x4screens)...For RMF-V4011	23
(2) 200-inch (50-inch 4x4screens)...For RMF-V5011	24
(3) 160-inch (40-inch 4x4 screens)...For RMF-V4011R	25
CHAPTER 3. INSTALLATION AND ASSEMBLY	26
1. INSTALLATION CONDITIONS	26
(1) Installing Ground	26
(2) Ceiling	27
(3) Front Space	27
(4) Rear Space	27
(5) Number of Units Stacked Up	27
(6) Prevention of Tilting	27
(7) Calculating the Heat Quantity	28
(8) Temperature and Humidity	28
(9) Ventilation for system	29
(10) Condensation	30
(11) Visible Angle	31
(12) Lighting	34
(13) Effects of Earth Magnetism	34
(14) Connection with a Power Supply	35
(15) Cables Used	36
(16) Semi-outdoor Installation	36
(17) Precautions for Use of User-Obtained Parts	36
2. INSTALLATION AND ASSEMBLY	37
(1) Confirmation	37
(2) Opening the Packaging	37
(3) Carrying the Units After Opening Packaging	43
3. PRECAUTIONS FOR TRANSPORTATION	44
4. ASSEMBLING THE SYSTEM	45
(1) Assembling the Projection Frame (RMF-V4011/V5011)	45
(2) Assembling the System	46
5. SPECIAL INSTALLATION	60
(1) Wall inset	60
(2) Diagonal installation	60
(3) Architrave processing	60
(4) Upside down installation	60
(5) Hanging from ceiling	60
CHAPTER 4. ADJUSTMENTS	61
1. ADJUSTMENT PREPARATIONS	61
(1) Wiring	61
(2) Wiring Handling	61
(3) Aging	61

(4) Adjustment Signals	62
(5) Equipment Required for Adjustments	62
2. BEFORE ADJUSTMENTS	63
(1) Convergence Adjustment Memory	63
(2) TV System	64
(3) White Balance Adjustment Memory	65
(4) Combined Use of Remote Control and Personal Computer	65
(5) Memory of Adjustment Data and Settings	65
(6) Giving IDs	66
3. EXAMPLES OF MAIN USES OF CUBE SYSTEM	68
(1) Expansion/Individual Switching at Multi Video Processor Side-General example	68
(2) When Switching Source Inputs to Multi Video Processor	68
4. SCREEN ADJUSTMENTS	69
(1) Adjustment Flowchart	69
(2) Convergence Adjustment Flowchart	70
(3) Convergence Adjustment Contents	71
(4) White Balance Adjustment Flowchart	89
(5) White Balance Adjustment	90
(6) External Control by RS-232C	96
(7) Adjustments by Remote Control	108
CHAPTER 5. OPERATIONS · MAINTENANCE	120
1. MAINTENANCE	120
(1) Re-adjustments After 3 months	120
(2) Periodic Maintenance	120
(3) Replacement of Parts	120
2. PRECAUTIONS FOR PLAYING (MUTING)	128
3. PRECAUTIONS FOR ASSEMBLING AND MAINTENANCE	129
CHAPTER 6. PRECAUTIONS	130
1. PRECAUTIONS ON FUNCTION AND PERFORMANCE OF SYSTEM	130
Check sheet	132

WARNING 

- To prevent injuries and physical damages, always read and observe this manual and all labels on the unit before assembly, construction, and adjustments.
- Do not use the unit outdoors to prevent fire hazards and electric shocks caused by water entering the unit.
- To prevent injuries, take note of the sharp edges of this unit.
- When performing setup work at high places, to prevent the falling down of the unit and damages caused by falling objects, set the Keep Out area.
- To prevent fire hazards and electric shocks, do not place foreign objects in the unit nor remodel it.
- To prevent fire hazards, observe the following using environment.
 - Temperature : 5 to 35 °C
 - Humidity : 20 to 80%
 - *The above temperature and humidity are conditions for the multi-projection unit and screen separately, and not those of the system.
 - Perform ventilation with the fan etc. and observe the operating environment conditions even after completing assembly.
- Never install the system tilted.

CHAPTER 1. FEATURES OF PROJECTION CUBE SYSTEM

1. FEATURES OF SYSTEM

●Free combination of cubes

By combining cubic style projection cubes, various layouts can be realized. Combine the cubes as desired (four-screens, nine-screens, vertically in one row, horizontally in one row, etc.) according to the purpose of exhibition and installation location.

●Use in bright places

Realizing a high-luminance of 600ft-L (For white peak. RM-V2500N:420ft-L) for the screen brightness, it can be used adequately in lobbies and open spaces with external light.

●Ultra-thin mullion (approx. 3mm) when combined (RMS-V4011).

The width of the Pioneer cube gap is only about 3 mm (about 4 mm for RMS-V5011) even when combined. Thinner and more easy-to-view than before, the problem of missing images and characters has been resolved to a large extent.

●HDTV, WS IMAGE

By adding equipment, the system can also receive HDTV the next generation video format. High quality live-like images can be shown on a huge screen to a large crowd of viewers such as at event halls and show rooms.

2. FEATURES OF MULTI PROJECTION UNIT (RM-V2400N/V2500N)

●Improvement of adjusting method

- The convergence adjusting system has been changed from analog to digital. In addition to conventional adjusting methods, by adding the adjustment (point convergence) by 25 steps, adjustments have become more easy and accurate.
- By adding the linear white circuit, the white balance can be adjusted more precisely.

●The multi-projection unit can be mounted onto conventional cabinets (RM-V2400N) in addition to RMF-V4011R/V4011CR.

●Incorporates functions such as multi-switch which aim at high quality image for enlarged images and solid screen.

- Although peripheral light is given adequate luminance to construct the multi-screen, the multi switch is loaded to realize a huge screen with more consistent brightness by the peripheral light compensation circuit. It is also equipped with a function which performs contour correction during enlargement of images to provide natural and high quality enlarged images.
- The incorporated auto white balance function and ABL (auto brightness limiter) link function control inconsistencies of color and brightness between the screens.

●Wired remote control (RU-V107/Optional) for adjustments.

In the setting of the multi-screen system, using the wired remote control in convergence and white balance adjustments enables the images to be viewed at the same time. These adjustments are performed to obtain uniformity of the entire screen.

It is efficient for adjustments to be performed by several persons and in temporary adjustments.

- **Convergence memory**

Apart from the standard values set at shipment, up to 3 kinds of data can be memorized for the adjusting value.

- **Convenient "color mode selection switch" for camera-reexposure.**

A convenient "color mode selection switch" which can set two types of white balance data is provided. For example, when using the system as a monitor for reexposing in broadcast station studios, etc., images exposed using the camera according to the lighting of the studio will come out with unnatural colors. By setting the temperature of one color to 4500° K, natural color reproductions can be realized by one-touch operation.

- **On-screen function**

In addition to adjusting values, various data to set up conditions, can be displayed on the screen.

- **External control function**

A RS-232C external control terminal is equipped. Using a Personal Computer, various adjustments can be performed from the front and a variety of images can be played. The daisy-chain for connecting the combination terminal by the link control cable (DIN 6-pin/provided) can be performed in the transmission of control signals to each unit. Complicated connections are not required. By giving IDs to each unit, each unit can be adjusted individually even after the system has been started.

- **Corresponds to both NTSC and PAL formats (automatic differentiation).**

3. FEATURES OF FRAME TYPE

- **By adopting an unique mullion structure, ultra-thin gap (about 3 mm) (about 4 mm for RMS-V5011) ,when screens are combined, has been realized, thereby resolving the problem of missing images and characters.**

Projectors can be connected and disconnected from the front and rear even after installation. Therefore, checking, replacement, or maintenance can be performed easily.

- **Efficiency is the same as before. Up to five screens can be piled on top of each other without any reinforcement. Use of reinforcement enables the level to be increased.**

- **By adopting the frame structure, a mullion-less system can be realized.**

4. FEATURES OF CABINET TYPE

- **Outstanding durability due to its dynamic design using aluminum.**

- **As the cabinet need to be piled up only in installation, setup time is very short. It therefore proves efficient in cases where time is limited, conditions are harsh, etc. such as events.**

- **By adopting an unique mullion- structure, ultra-thin mullion- (about 3 mm) (when screens are combined) has been realized, thereby resolving the problem of missing images and characters.**

- **The RM-V2400N or RM-V4000V, RMA-V2130 can be mounted.**

*RMF-V2130 can not be mounted onto the RMF-V4011CR.

- **RMF-V4011R and RMF-V4011CR can be incorporated in the same system since their cabinets are of the same size. But as for RMF-V4011CR, it is necessary to replace RMF-V4011R's screen because it is different.**

CHAPTER 2. GENERAL SPECIFICATIONS

1. SPECIFICATIONS

(1) Multi Projection Unit (RM-V2400N/V2500N)

TV format	NTSC, PAL automatic selection (Each mode provided)	Computer control:	
Projection tube	7-inch CRTx3	Method	RS-232C (D-SUB 25PIN)
Horizontal resolution	800 TV lines (In video input mode)*1	Speed	1200, 2400, 4800, 9600, 19200 BPS*2
Luminance (For white peak)	600ft-L(40-inch)*1 420ft-L(50-inch)*1	Power supply voltage	
Practical visible	angle Horizontal direction 150 deg Vertical direction 60 deg *1	for RM-V2400NA/V2500NA ...	AC100V to 120V, 50/60Hz
Input signals:		Power supply voltage	
Video input; Standard input level (75 ohm load) 1 Vp-p		for RM-V2400NE/V2500NE ...	AC220V to 240V, 50/60Hz
Input terminal:	BNC connectorx1	Normal Consumption power	
Y/C separation input; Standard input level (75 ohm load)		for RM-V2400NA/V2500NA	approx. 360 VA*4
Luminance (Y) signal 1 Vp-p (With sync signal)		Normal Consumption power	
Color (C) signal:286 mVp-p (Burst signal <NTSC>)		for RM-V2400NE/V2500NE	approx. 240 W*4
300 mVp-p (Burst signal <PAL>)		Maximum Consumption power	
Input terminal:	BNC connector (Y and Cx1 each)	for RM-V2400NA/V2500NA	400VA
RGB input	Analog R, G, B signals	Maximum Consumption power	
RGB-1 : D-Sub 9-pin connectorx1*3		for RM-V2400NE/V2500NE	275W
RGB-2 : BNC connectorx5*3		AC outlet (Max. 8A, AC100V to 120V)	
R:Red input	0.7 Vp-p±2dB, terminated at 75 ohm, positive polarity	for RM-V2400NA/V2500NA	x 1
G/G SYNC:Green input	0.7 Vp-p±2dB, terminated at 75 ohm, positive polarity	AC outlet (Max. 550W, AC220V to 240V)	
Green input with SYNC	0.7 Vp-p±2dB, terminated at 75 ohm, positive polarity	for RM-V2400NE/V2500NE	x 1
B:Blue input	0.7 Vp-p±2dB, terminated at 75 ohm, positive polarity	External dimensions	680 (W)x490 (H)x545 (D) mm
SYNC/HD:Composite sync input	0.3Vp-p to 4Vp-p, terminated at 75 ohm, negative polarity	Weight	38 kg (Main unit)
Horizontal sync input:	0.3Vp-p to 4Vp-p, terminated at 75 ohm, negative polarity	Accessories	
VD:Vertical sync input:	0.3Vp-p to 4 Vp-p, terminated at 75 ohm, negative polarity	Power cord	x 1
Sync. signal frequency: Frequency is in accordance with	NTSC or PAL.	Cable clip	x 1
EXT control:	BNC connector	Screw	x 1
Remote input:	Mini jack	Control cable (ABL link cable)	x 1
Linked input:	6PIN DIN connector	*Used for controlling several multi-projection units.	
Output signal			
Video output	Standard level (75 ohm load) 1 Vp-p	*1 Projection Screen Kit(RMS-V4011/V5011)	
Outputs input signal from input terminal		Projection Frame(RMF-V4011/V5011)	
Remote output	6PIN DIN connector	Specifications when installed as specified above.	
		*2 The RS-232C baud rate is set to 4800BPS before ship-	
		ment. The baud rate is controlled by Remote control	
		unit or a personal computer.	
		*3 Either RGB1 or 2 is used by switch selection.	
		*4 For NTSC or PAL COLOR BAR signal input and each	
		adjustment data is shipment condition.	

Dimensions

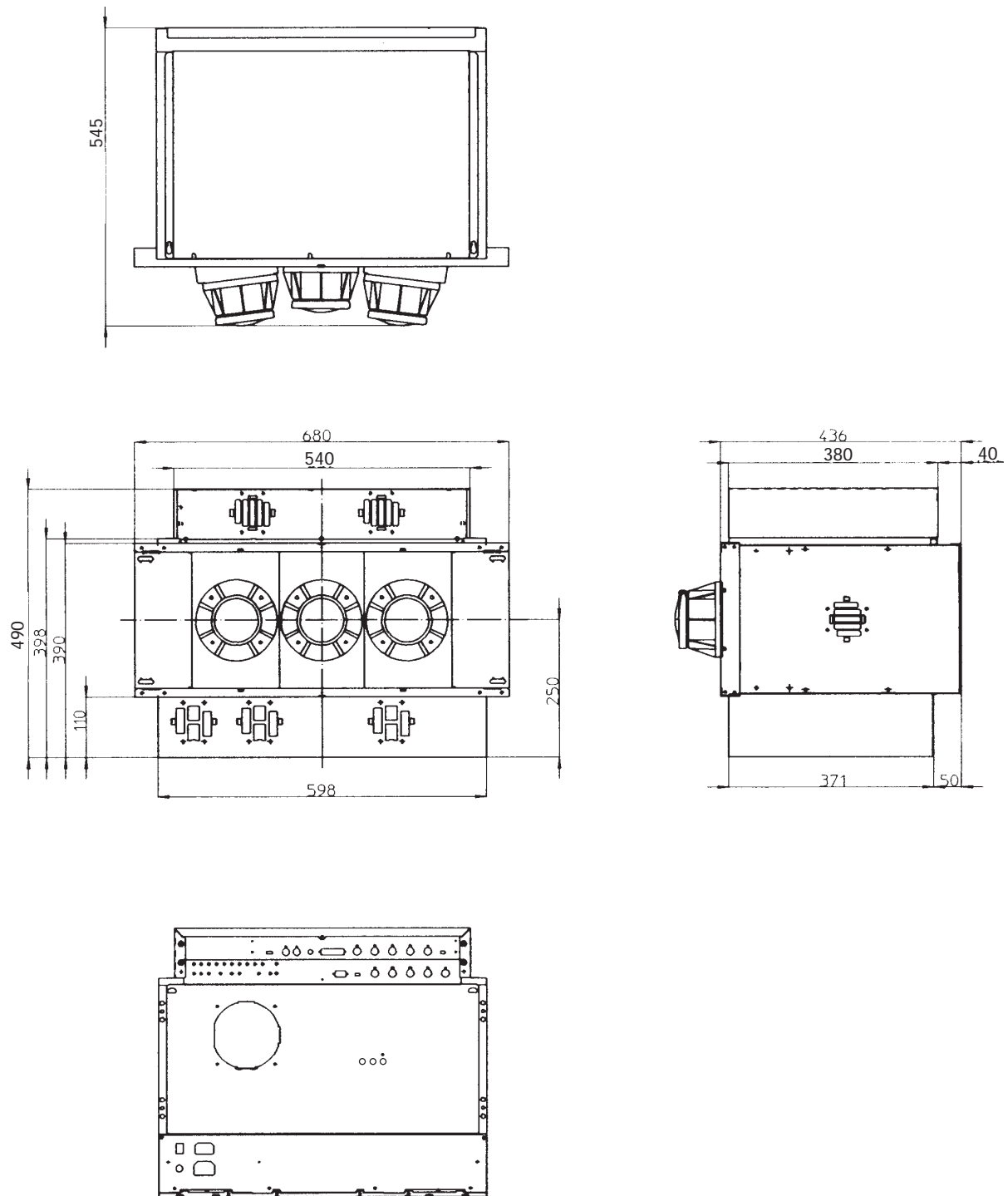

(Fig.2-1)

Power Supply Panel

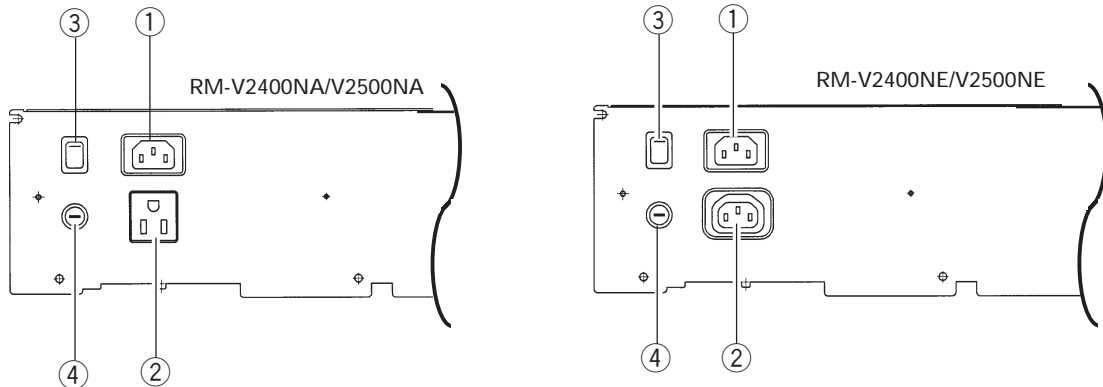

(Fig. 2-2)

No.	Name	Type	Function
①	AC inlet		Connects AC power cord.
②	AC outlet		Connects other multi-projection units. Not linked to main power switch. Note 1)
③	Main power switch	See-saw switch	Turns on and off the power supplied to the main unit. Sets into the standby state when turned on.
④	Fuse holder		Stores the fuse. No-one except serviceman should touch this part.

Note 1) Refer to page 35 [(14) Connection with a power supply ③ Connection].

Control Panel

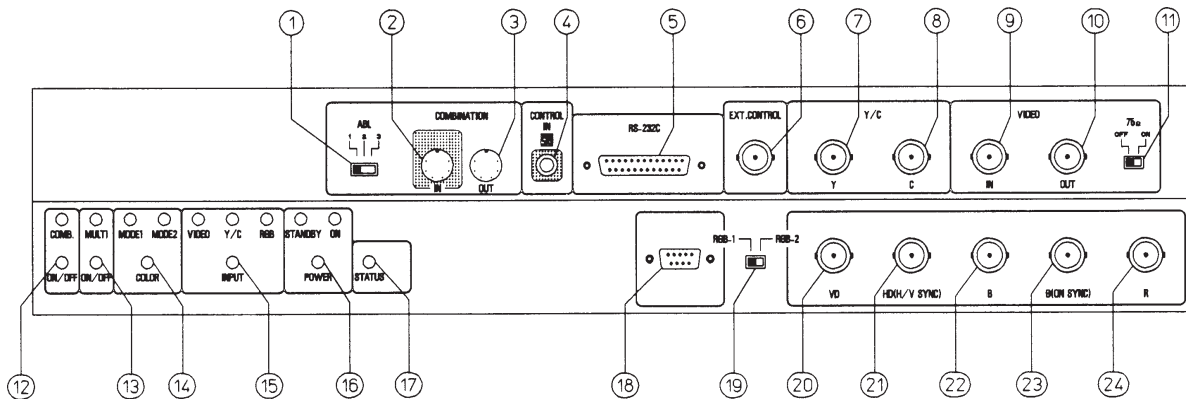

(Fig. 2-3)

GENERAL SPECIFICATIONS

No	Name	Type	Function
①	ABL link switch	Slide switch	Used for switching the control level of the ABL link control voltage when ABL link is ON.
②	Linked input terminal	DIN 6PIN	Input terminal of ABL signal, remote control signal and RS-232C signal
③	Linked output terminal	DIN 6PIN	Output terminal of ABL signal, remote control signal, and RS-232C signal
④	Remote control connection terminal	Mini jack	Connected to adjusting remote control (optional)
⑤	RS-232C port	D-sub 25 PIN (Female)	RS-232C communication connector
⑥	Control input terminal	BNC connector	Video input and Y/C input external switching control signal input terminal (Normal(video signal input) : Open Select Y/C input : Low(0V)
⑦	Y (Luminance) input terminal	BNC connector	Luminance signal input terminal
⑧	C (Color) input terminal	BNC connector	Color signal input terminal
⑨	Video input terminal	BNC connector	Video signal input terminal
⑩	Video output terminal	BNC connector	Video input terminal ⑨ through-out terminal
⑪	TERMINATE switch	Slide switch	Turns on when terminates the video input terminal ⑨ at 75 ohm
⑫	COMBINATION switch	Tact switch	Turns on when linked to ABL
⑬	MULTI switch	Tact switch	Turns on when used on multi screen
⑭	COLOR MODE switch	Tact switch	Switches the color temperature. 1:Normal use. 2:Re-exposure
⑮	INPUT switch	Tact switch	Switches VIDEO input, Y/C input, RGB input. Switches VIDEO input and Y/C input with the external control signal ⑥ at VIDEO position
⑯	POWER switch	Tact switch	Power OFF : STANDBY (Red LED) lights up Power ON : ON (Green LED) lights up
⑰	STATUS switch	Tact switch	Accumulated duty time: * Switch which displays setting states of each switch on the screen.
⑱	RGB input terminal	D-sub 9PIN (Male)	RGB signal input terminal
⑲	RGB input select switch	Slide switch	Switches RGB signal input terminal type
⑳	RGB input terminal (Vertical sync)	BNC connector	RGB signal vertical sync input terminal
㉑	RGB input terminal (Horizontal sync/composite sync)	BNC connector	RGB signal horizontal sync and composite sync (Only for input signal H/V sync) input terminal
㉒	RGB input terminal (B)	BNC connector	RGB signal B input terminal
㉓	RGB input terminal (G/composite sync)	BNC connector	RGB signal G and composite sync (Input signal G on sync) input terminal
㉔	RGB input terminal (R)	BNC connector	RGB signal R input terminal

- To turn off the power, use the POWER switch - of the unit, the RS-232C control, or wired remote control (optional). (If turned off using the main POWER switch or by disconnecting the power cable from the outlet, the settings of the above ⑫ to ⑮ switches and the state of the TV SYSTEM and convergence memory will not be recorded on the memory.)
Consequently when starting up or stopping the whole system by AC ON/OFF in setup conditions for a demonstration, it is necessary to turn off the power using the above method to record each setting in the memory.
(Refer to "CHAPTER 4. ADJUSTMENTS, (5) Equipment Required for Adjustments".)

* : Accumulated duty time
Counts only when the power is ON.

CONTROL PANEL MODE Switches

●COMBINATION switch



Position	Function
OFF	ABL link is off
ON	ABL link is on

• Turns on or off each time it is pressed. The LED lights up when turned on.

●MULTI switch



Position	Function
OFF	Changes to a picture quality suitable for single screen
ON	Changes to a picture quality suitable for multiple screens

• Turns on or off each time it is pressed. The LED lights up when turned on.

●COLOR MODE switch

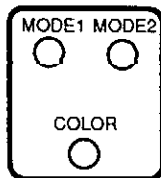

Position	Function
MODE1	Sets the normal use color temperature. MODE1 LED lights up when selected.
MODE2	Sets the re-expose color temperature. MODE2 LED lights up when selected.

• Sets to MODE1/MODE2 each time it is pressed.

●INPUT SELECT switch

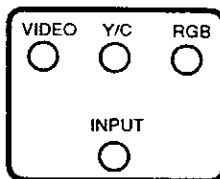

• The input switches each time this switch is pressed.

Position	Function
VIDEO	The VIDEO input terminal is selected. When selected, the VIDEO LED lights up. When switching to VIDEO or Y/C input by inputting the control signal to the EXT.CONTROL terminal, select this position. <EXT. CONTROL> The VIDEO or Y/C input is selected when the control signal is input to the EXT.CONTROL terminal (BNC). In this case, the VIDEO LED remains lit. Control signals High:VIDEO Low:Y/C The High state is set when the control input terminal is released (normal state). The VIDEO input signal will be selected.
Y/C	The Y/C input terminal is selected. When selected, the Y/C LED lights up.
RGB	The RGB input terminal is selected. When selected, the RGB LED lights up.

●STATUS switch

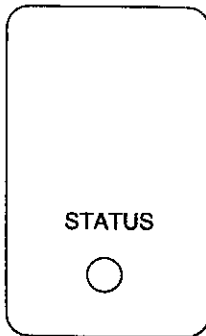

- The display changes cyclically each time it is pressed.
The settings can be checked.

Display Example)

1.HOUR	10000 H
2.INPUT	VIDEO
3.MULTI	ON
4.COLOR MODE	1
5.COMBI.	ON
6.VIDEO MODE	ON
7.BAUD RATE	4800BPS
8.TV SYSTEM	AUTO/NTS
9.CONV. DATA	MEMO-1

- 1:Displays the accumulated duty time. (It only counts during the power ON.)
- 2:Displays the input state. Note)
- 3:Displays the MULTI ON/OFF state.
- 4:Displays the COLOR MODE 1/2 state.
- 5:Displays the COMBINATION ON/OFF state.
- 6:Shows the muting ON/OFF state of the image when the input function is switched.
- 7:Displays the communication speed in computer control.
- 8:Displays the TV SYSTEM state.
- 9:Displays the memory area of the convergence selected.

[RGB-1 Terminal]

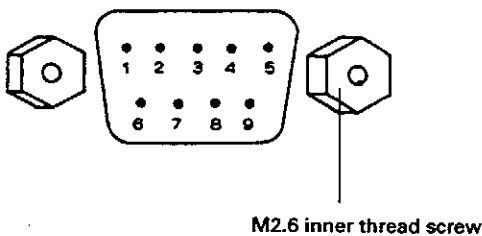

- Analog RGB : 0.7Vp-p (75ohm)
- Sync signal : 0.3Vp-p to 4Vp-p (75ohm)
- Connector : 9-pin D SUB Connector (Male)

- Pin Assignment
- | | |
|----------------|--------|
| 1: R | 6: GND |
| 2: G/Sync on G | 7: VD |
| 3: B | 8: NC |
| 4: Signal GND | 9: NC |
| 5: HD/Sync | |

[VIDEO Input]

The video output terminal is the input through-out terminal. When connecting to other units, terminate the terminal of the unit to be connected at 75 ohm, and turn off the 75 ohm TERMINATE switch of the main unit. When not connecting other units, always turn on this switch.

GENERAL SPECIFICATIONS

POWER SUPPLY outlet ⚠

- Power supply outlet (No-switch linkage:Below 8A)
For multi-projection unit expansion. Do not use for other purposes.
- Power supply outlet power consumption
Up to two multi-projection units can be connected to one multi-projection unit.

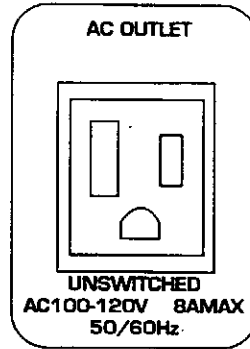

RM-V2400NA/V2500NA

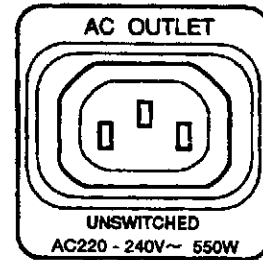

RM-V2400NE/V2500NE

Focus Adjustment

Adjustment	Input Signal	Adjusting Point	Adjusting Method
Focus adjustment	Cross hatch	Focus control (VR1) of lens assembly attached to the replaced CRT assembly and the focus variable resistor	<ul style="list-style-type: none"> • Move the lens assembly left and right and optimize the focus. • Rotate the focus VR and optimize the focus. • Adjust the lens assembly and focus VR repeatedly. <p>Note 1 : Perform the following adjustment again only when the blue focus has been adjusted. Rotate the blue focus VR in the counter clockwise direction and enlarge the blue color vertically until it barely projects out of its area. (The outer most vertical lines of the crosshatch are 10 to 12 mm for 40 inch, and 13 to 15 mm for 50 inch) Rotate the focus VR by about 10 deg (approximate for your reference).</p> <p>Note 2 : By inserting the screwdriver from the hole on the rear panel, adjustments can be carried out without removing the rear panel. There is a dot mark above the blue hole (B). (See figure below.)</p>

Note) ASK our servicemen if the Focus VR needs to be adjusted.

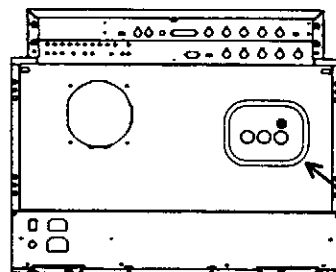

Holes for the adjustment (Right side hole is for Blue.)

Rear panel

(2) Projection Screen Kit (RMS-V4011/V5011) Product Weight : 11.0 kg/14.0kg

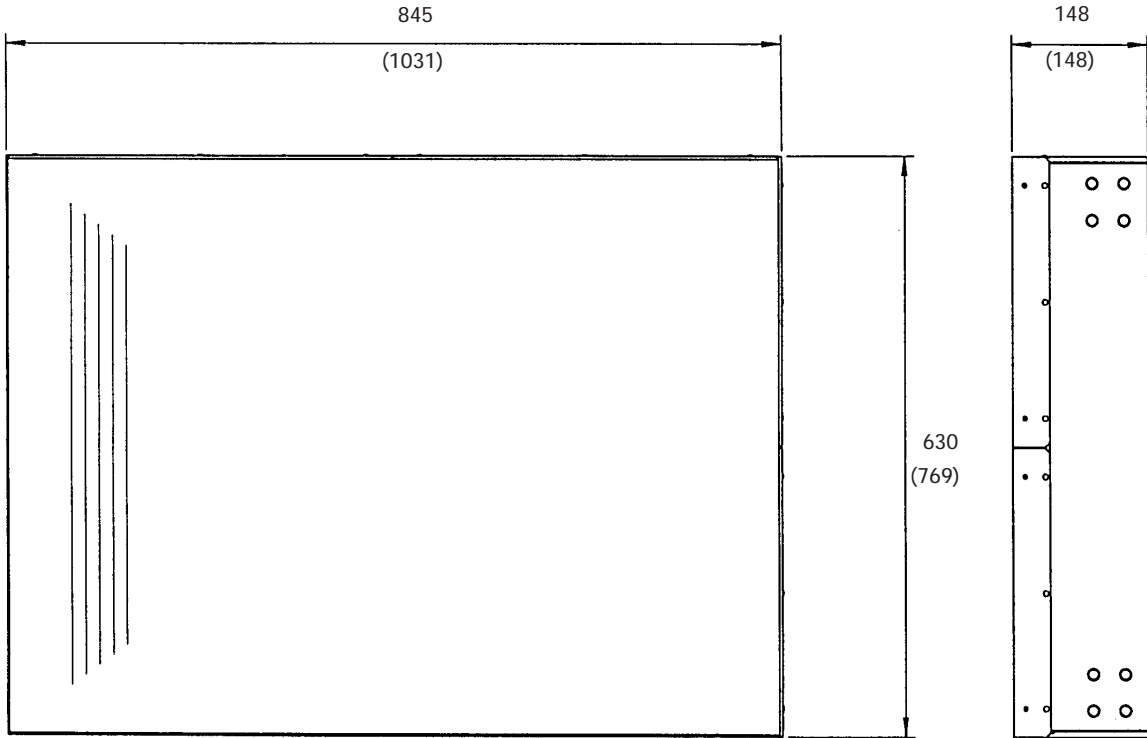

(Fig.2-4)

Unit:mm

The number in parentheses is the dimension for RMS-V5011

Accessory

Screw rivet 6

(3) Projection Frame (RMF-V4011/V5011) Product Weight : 26.8kg/28.8kg

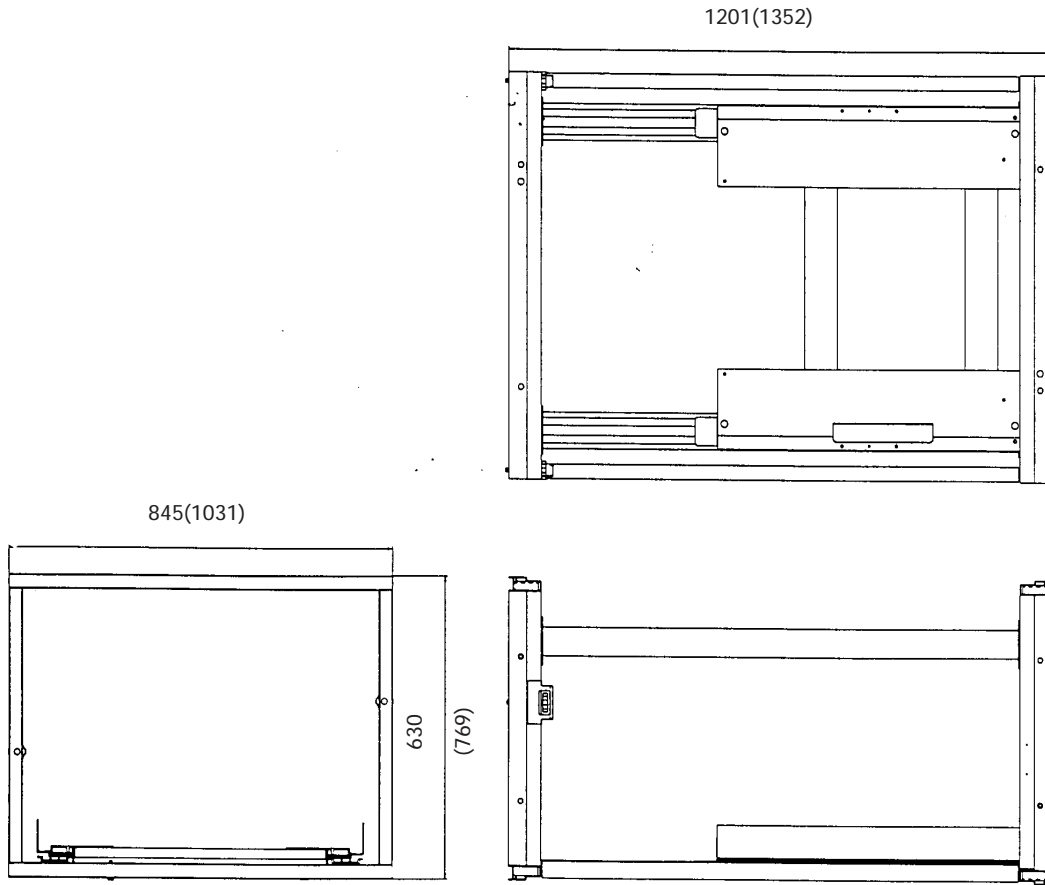

(Fig.2-5)

Unit:mm

The number in parentheses is the dimension for RMS-V5011

Accessories

Metal fixture (R)	1
Metal fixture (L)	1
Stopper	2
Screw M5x10	38+2
Screw M5x35	6
Screw M5x50	4
Hexagon head bolt (with washer) M8x45	8
Shield	1
Rivet	2

(4) Projection Cabinet (RMF-V4011R/V4011CR)

① RMF-V4011R *

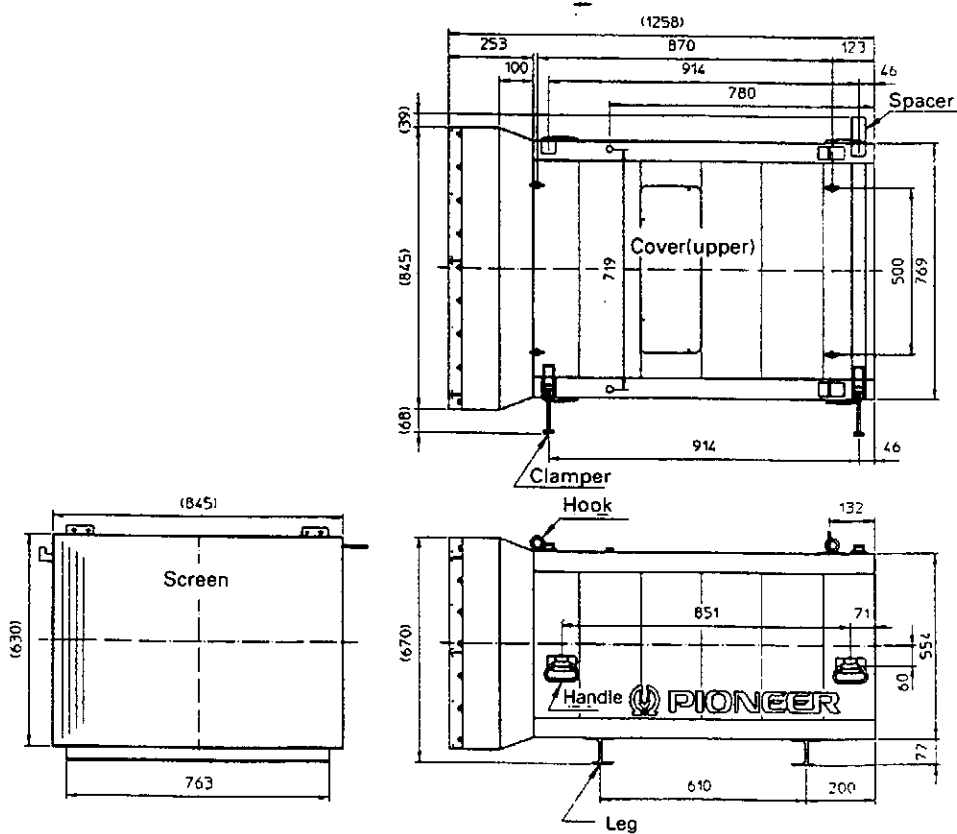

(Fig.2-6-1)

Specifications

External dimensions 845 (W)×670 (H)×1258 (D)mm

Weight 56.0kg

Screen size 840.4 (W)×625.4 (H)mm

Component parts (RM-V2400N fittings)

Frame R [BNG1207]	1
Frame L [BNG1208]	1
Holder (R) [BNG1150]	1
Holder (L) [BNG1151]	1
Attachment (R) [BNG1173]	2
Attachment (L) [BNG1174]	2
Rear holder R [BNG1205]	1
Rear holder L [BNG1206]	1
Rear panel R (upper) [BMR1069]	1
Rear panel L (upper) [BMR1070]	1
Rear panel R (lower) [BMR1071]	1
Rear panel L (lower) [BMR1072]	1

Cushion A [BMR1106]	1
Cushion B [BMR1107]	2
Hinder panel [BMR1075]	2
Adjuster [BEF1011]	2
Cover [BNE1012]	1
Screw (M5×15)[PMB50P150FZB]	18 (spare×2)
Screw (M5×50) [PMB50P500FZB]	4
Screw (M5×20) [PMB60P200FZB]	4
Screw (3×12) [ABA1167]	4
Screw (3×8) [BBZ30P080FZK]	10
Nut (M8) [NA80FZK]	2

* :RM-V4000V can use the same cabinet.

GENERAL SPECIFICATIONS

② RMF-V4011CR

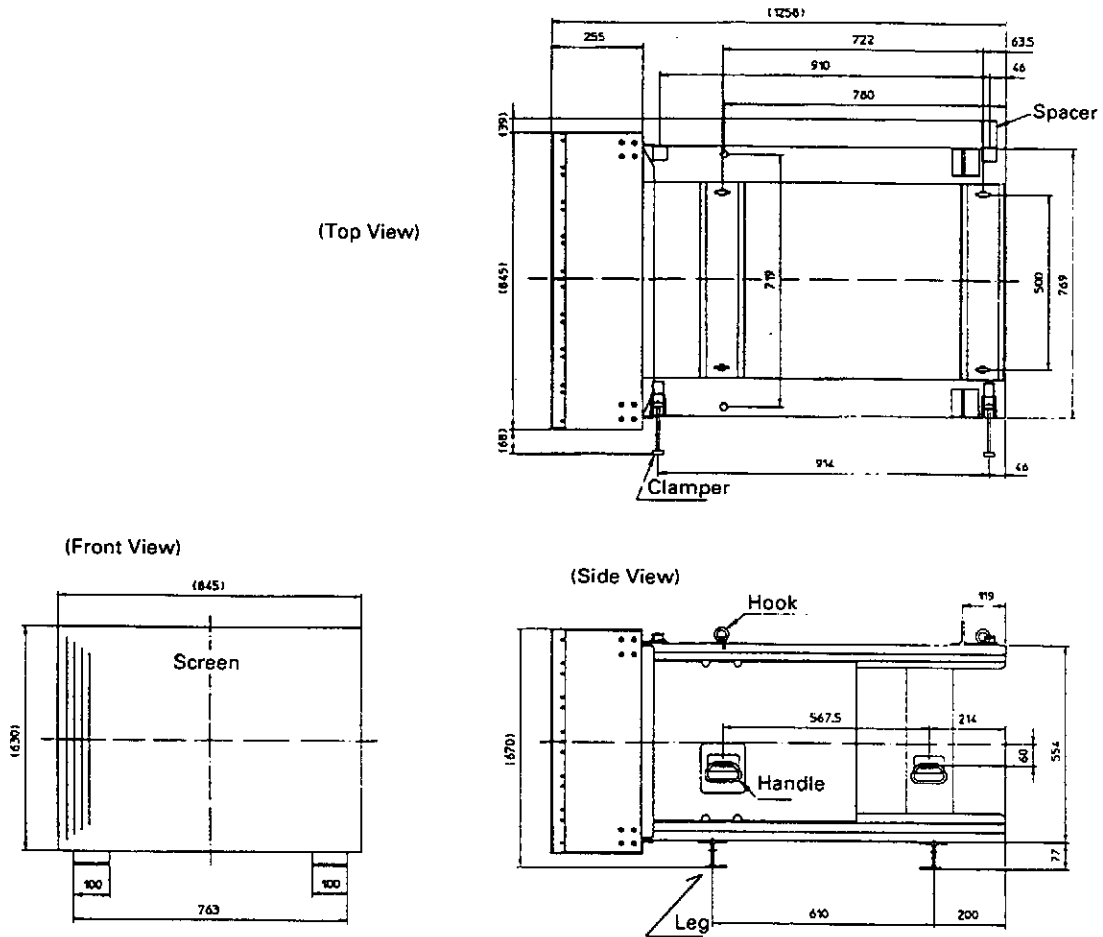

(Fig.2-6-2)

Specifications

External dimensions 845 (W)×670 (H)×1258 (D)mm

Weight 45kg

Screen size 840.4 (W)×625.4 (H)mm

Component parts (RM-V2400N fittings)

Engine guide [BND1099] 2

Attachment (R) [BNG1173] 1

Attachment (L) [BNG1174] 1

Screw (M5×12) [HMB50P120FZB] 8

Screw (M6×50) [HMB60P500FZB] 4

Screw (M6×20) [HMB60P200FZB] 2

* :RM-V4000V can also use the same cabinet.

(5) Projection Install Table (RM-V112/RMA-V5010)

① **Projection Install Table(RM-V112)...For only RMF-V4011**

Base weight : 61.2kg
 Integrated weight : 62kg
 Dimension [Include packing] (W × H × D) : 920 × 795 × 1370mm

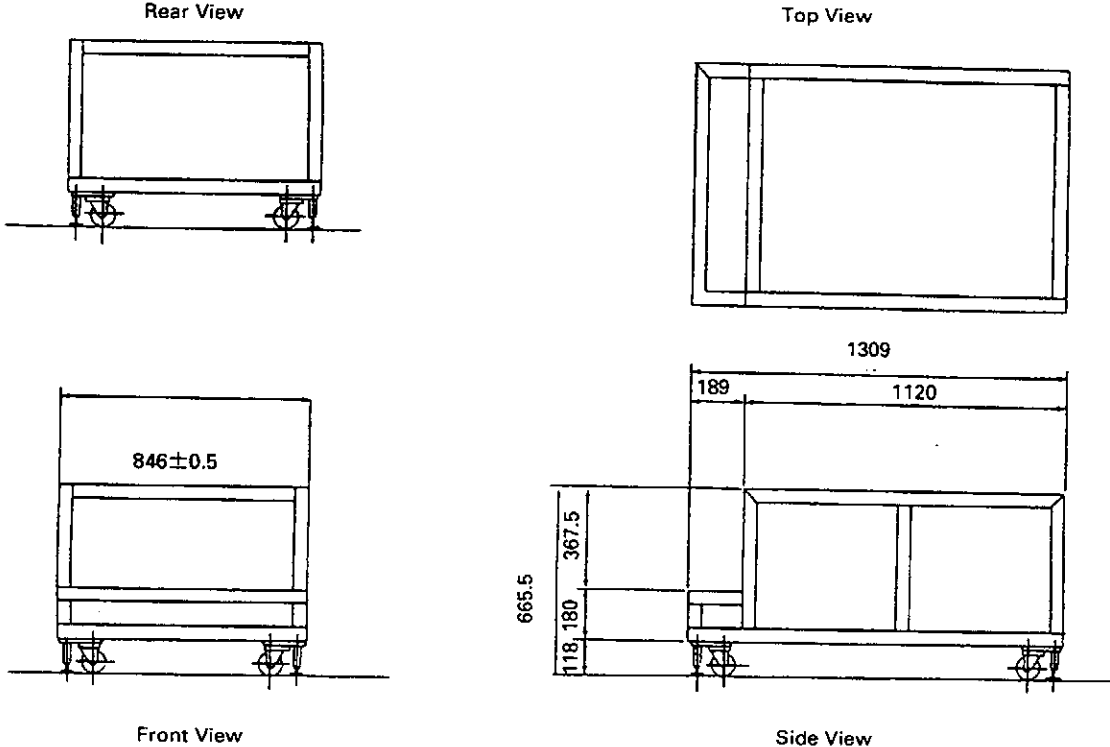

(Fig.2-7)

② **Projection Install Table(RMA-V5010)...For only RMF-V5011 (with Munting Unit)**

Making inquiries separately.
 Base weight : 67.4 kg
 Dimension [include packing] (W × H × D) : 1140 × 780 × 1430 mm 77.0 kg

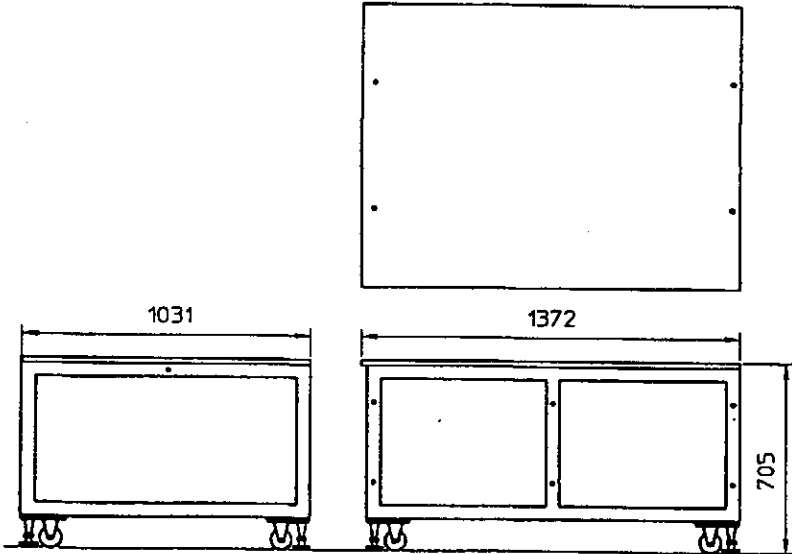

(Fig.2-8)

(6) Mounting Unit (RMA-V2050/V2060)

① **Double mounting unit (RM-V2050) (for RMF-V4011R / V4011CR only)**

Base weight : 34.0kg

Integrated weight : 70kg

Dimension [Include packing] (W × H × D) : 1850 × 340 × 1460mm

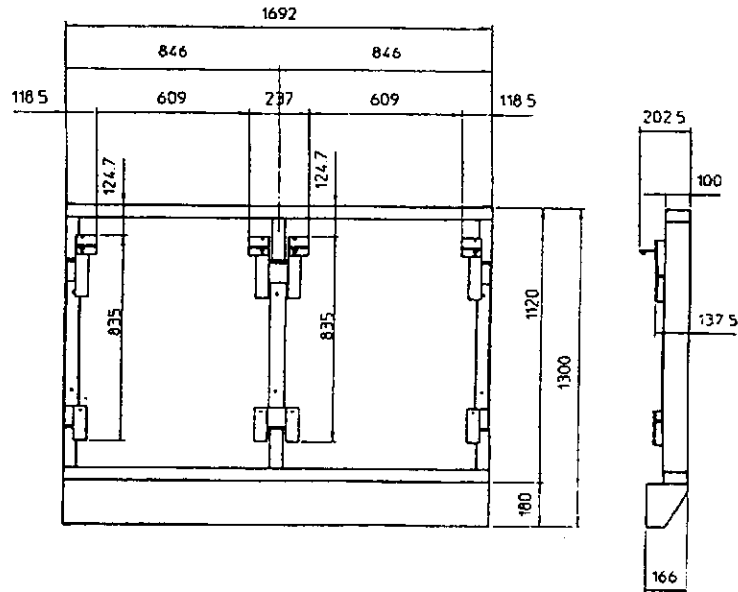

(Fig.2-9)

② **Triple Mounting unit(RMA-V2060) (for RMF-V4011R / V4011CR only)**

Base weight : 43.0 kg

Dimension [include packing] (W × H × D) : 2690 × 340 × 1460 mm

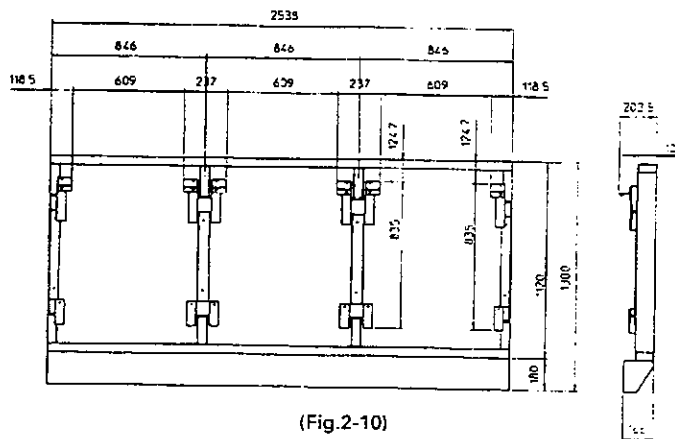

(Fig.2-10)

(7) Multi Video Processor (RMD-V3216/V3109, RMD-V2170)

① Multi Video Processor (RMD-V3216/V3109)

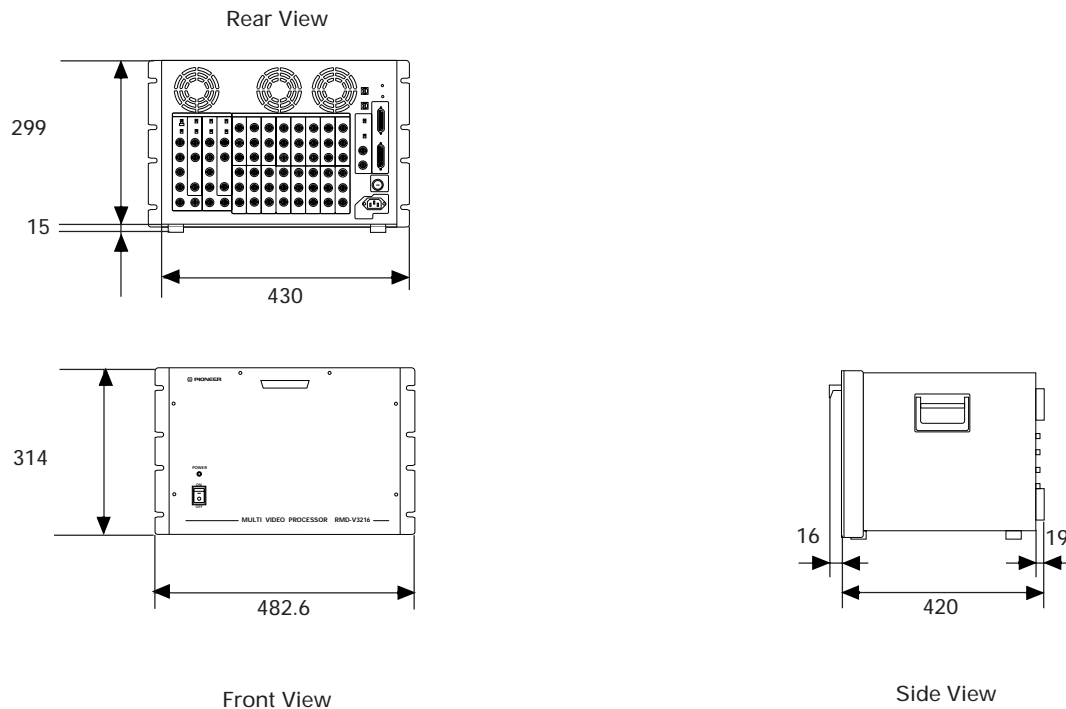

(Fig.2-11)

Main Specifications of Multi Video Processor (RMD-V3216/V3109)

Input signal

Input video signal (Can be expanded up to four systems)
2-line (RMD-V3216), 1-line (RMD-V3109) ... BNC terminal

- ① Composite video signal 1.0 Vp-p (75ohm terminated)
- ② Y/C separation signal
 - Y (With sync) 1.0Vp-p (75ohm)
 - C burst level 0.286 Vp-p (75ohm)

*1 or 2 signal format can be selected
*Only 1 has a terminate switch, throughout

Input standard sync signal BNC terminal

- ① Composite sync signal 0.286 to 4.0 Vp-p
- ② Composite video signal
 - Video level 0 to 0.714 Vp-p (75ohm)
 - Single level 0.286 Vp-p (75ohm)

*Terminate switch, throughout

RS-232C control input 25-pin D-SUB

Output signal

Output video signal

16-line (RMD-V3216), 9-line (RMD-V3109) ... BNC terminal

- ① Composite sync signal 1.0 Vp-p (75ohm)
- ② Y/C separation signal
 - Y (With sync) 1.0Vp-p (75ohm)
 - C (With burst) Burst level 0.286 Vp-p (75ohm)

*① and ② signal formats are output simultaneously.

③ RGB signal

- Green (Sync on Green) 1.0 Vp-p
- SYNC 0.3 Vp-p
- B.R 0.7 Vp-p

Output reference composite sync signal BNC terminal
TTL level

(Or input reference sync signal throughout)

Others

Power supply AC100 to 120V (50/60 Hz)

Power consumption
..... (RMD-V3216, RMD-V3109) 350W, 700VA

Operating temperature and humidity range
..... 5 °C to 35 °C

Below 85% (No condensation)

External dimensions (RMD-V3216, RMD-V3109)
..... 482.6 (Width)x420 (Depth)x314 (Height) (mm)
(Excluding handle)

Weight

RMD-V3216 22.5 kg

RMD-V3109 22.0 kg

Accessories

Rack mounting screw M5 8

Rack mounting washer 8

② Multi Video Processor (RMD-V2170)

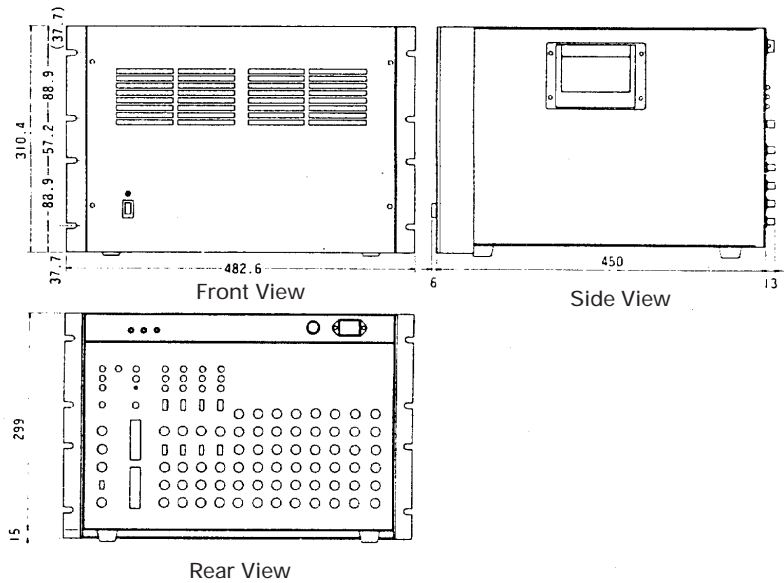

(Fig.2-12)

Main Specifications of Multi Video Processor (RMD-V2170)

Input video signal NTSC format
 Input signal band Above 4.2 MHz

Input

Video input

Input signal
 NTSC composite video signal (BNC)
 Input system 4-line
 Standard input level 1Vp-p (75 load)

Y/C separation

Input signal NTSC Y/C separation signal (BNC)
 Input system 4-line
 Standard input level Y:1 Vp-p (75 load)
 C:286 mVp-p (75 load burst signal)

*The video input or Y/C separation input is to be selected by the switch on the rear panel.

Reference sync signal input

Input signal Composite sync (BNC)
 Standard input level
 Composite sync 0.3 to 4 Vp-p

Control input

Input signal Conforms to RS-232C (25-pin, D-sub)

Output

Video output

Output signal
 NTSC composite video signal (BNC)
 Output system 16-line
 Standard output level 1Vp-p (75 load)

Y/C separation output

Output signal ... NTSC Y/C separation signal (BNC)
 Output system 16-line
 Standard output level Y1 Vp-p (75 load)
 C286 mVp-p (75 load, burst signal)

Test signal output

Output signal
 NTSC composite video signal (BNC)
 Standard output level 1Vp-p (75 load)
 Sync signal output TTL level (BNC)

Power supply voltage 100 to 120V, 50/60 Hz

Power consumption 300W/500VA

External dimensions 483 (W)x314 (H)x469 (D) mm

Weight 33 kg

*Line up series of RMD-V2110 with 9 OUTPUT CIRCUITS.

(8) Adjustment Control Unit (RU-V107)*Option

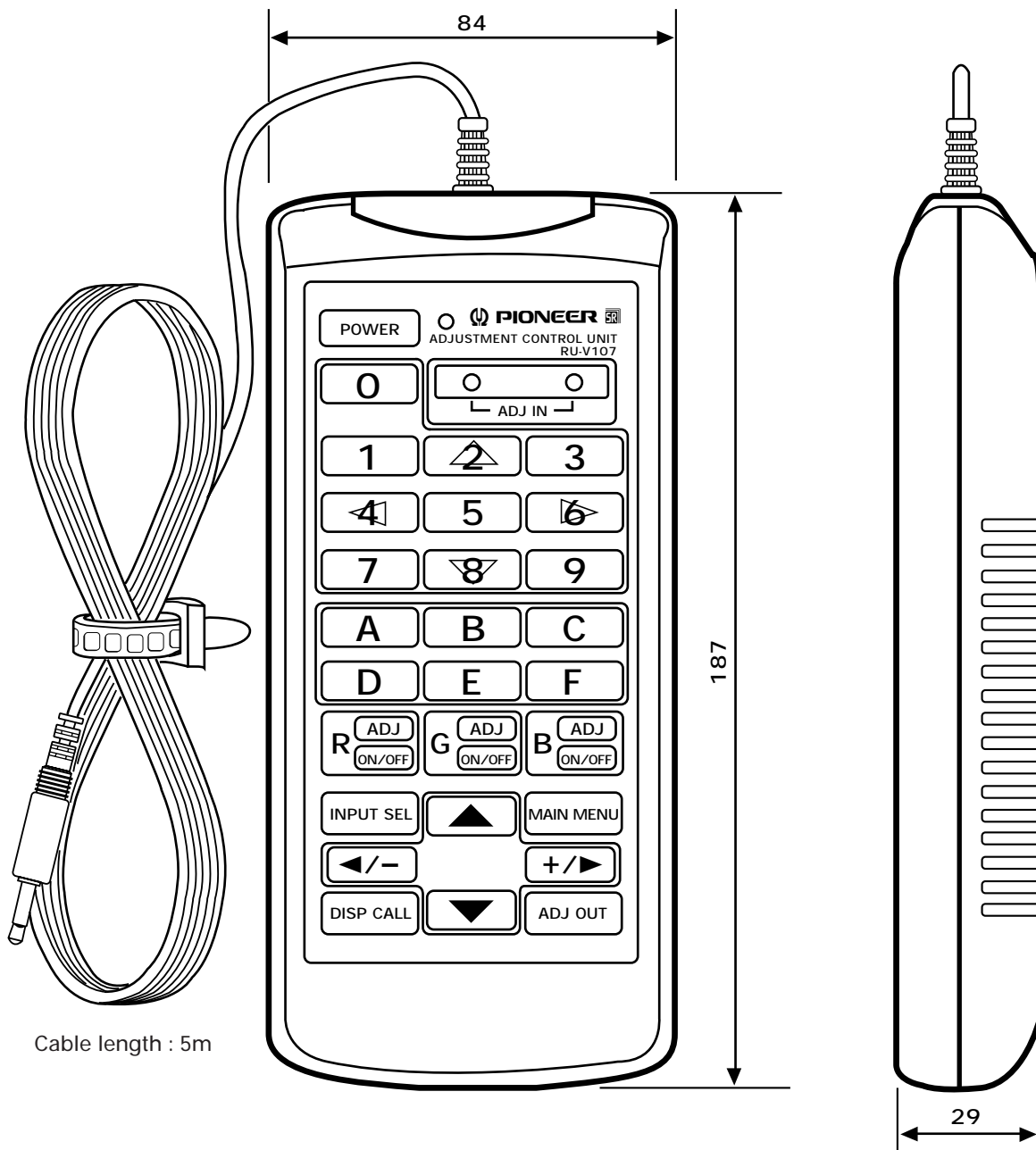

(Fig.2-13)

Accessories

AA dry battery (IEC R6P)	2
Cable (5m)	3

(9) Projection Cabinet (RMF-V4011R) Accessories

To attach the multi-projection unit (RM-V2400N) to the conventional RM-V2000A, the RMF-V4011R accessories (metal fixtures) are required. The following lists the required parts. For details of attaching the multi-projection unit, refer to Chapter 3. "4-(2)Assembling the System".

Frame R (BNG1207)	1
Frame L (BNG1208)	1
Holder (R) (BNG1150)	1
Holder (L) (BNG1151)	1
Attachment (R) (BNG1173)	2
Attachment (L) (BNG1174)	2
Rear holder R (BNG1205)	1
Rear holder L (BNG1206)	1
Rear panel R (upper) (BMR1069)	1
Rear panel L (upper) (BMR1070)	1
Rear panel R (lower) (BMR1071)	1
Rear panel L (lower) (BMR1072)	1
Cushion A (BMR1106)	1
Cushion B (BMR1107)	2
Hinder panel (BMR1075)	2
Adjuster (BEF1011)	2
Screw (M5x15) (PMB50P150FZB)	18 (Spare 2)
Screw (M5x50) (PMB50P500FZB)	4
Screw (M6x20) (PMB60P200FZB)	4
Screw (3x12) (ABA1167)	4
Screw (3x8) (BBZ30P080FZK)	10
Nut (M8) (NA80FZK)	2

Note : RM-V4000V can assemble with the same accessories.

2. SYSTEM DIMENSIONS

(1) 160-inch (40-inch 4×4 screens)...For RMF-V4011

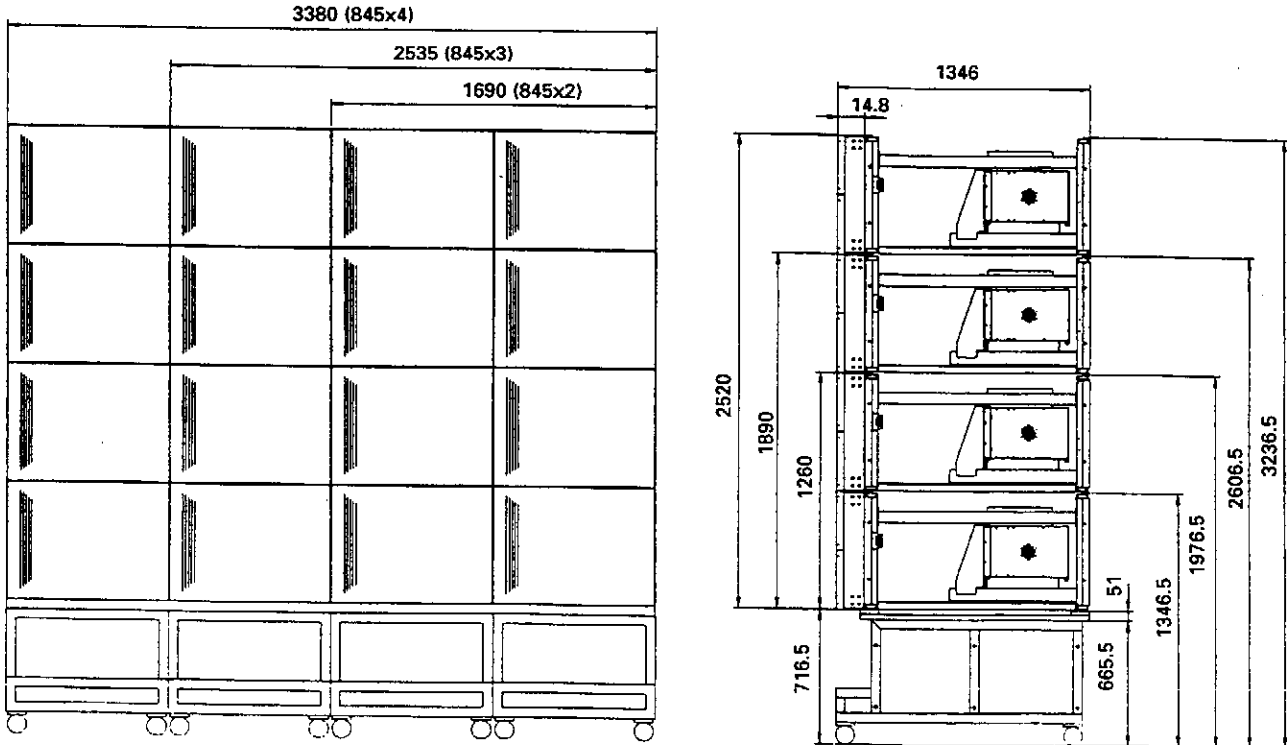

(Fig.2-14)

• As the plate thickness and screw head height are added, external dimensions will increase when cabinets and side boards, etc. are used.
Refer to Fig. 3-39 for the position of the bolts.

GENERAL SPECIFICATIONS

(2) 200-inch (50-inch 4×4 screens)...For RMF-V5011

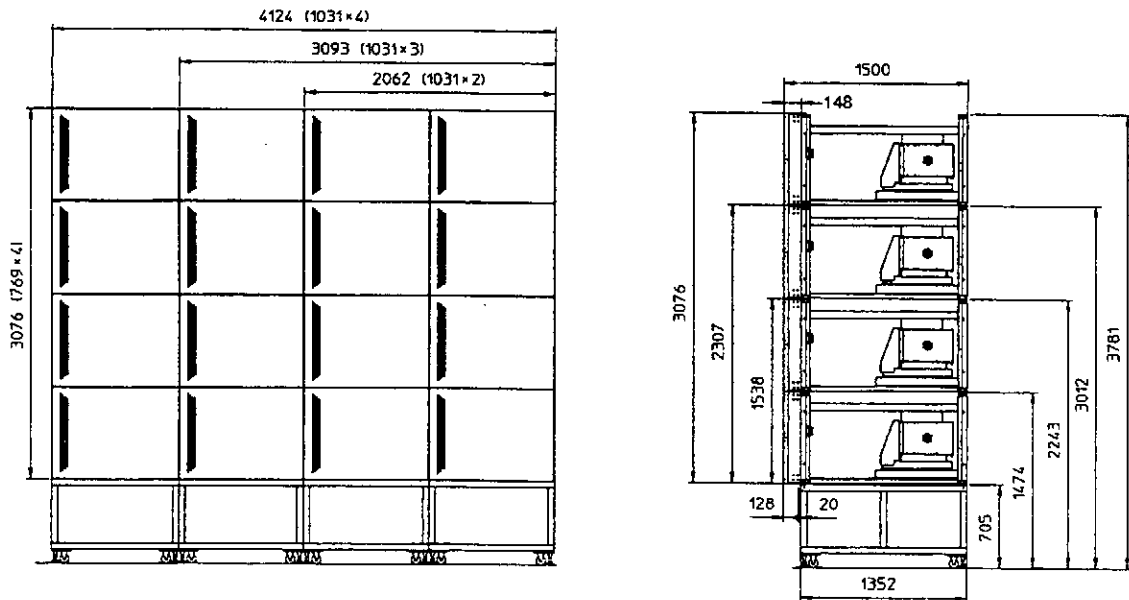

(Fig.2-15)

• As the plate thickness and screw head height are added, external dimensions will increase when cabinets and side boards, etc. are used.
Refer to Fig. 3-39 for the position of the bolts.

(3) 160-inch (40-inch 4×4 screens)...For RMF-V4011R

• RMF-V4011CR is the same size.

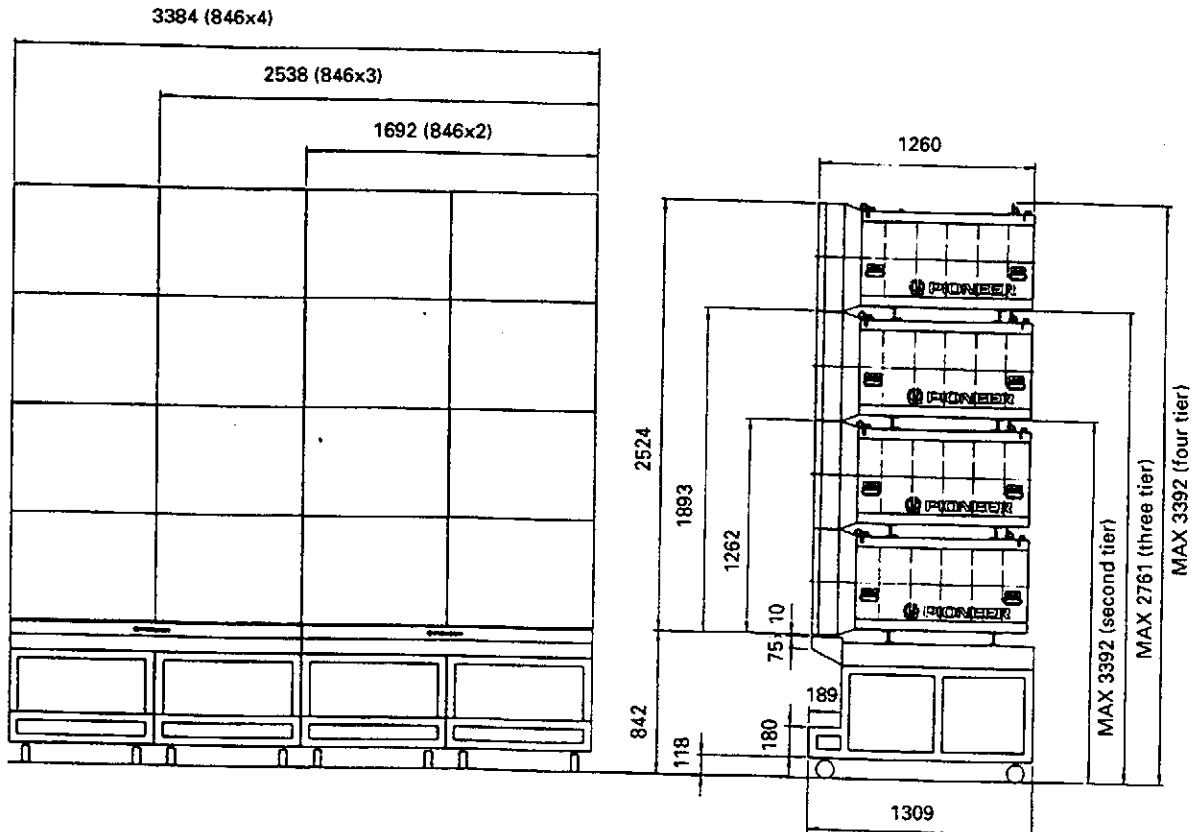

(Fig.2-16)

CHAPTER 3. INSTALLATION AND ASSEMBLY

1. INSTALLATION CONDITIONS

(1) Installing Ground

① Ground

The ground must be flat and horizontal. It should be able to bear the weight of the system.

For wooden floors, if the part receiving the weight of the system lies at the center between the reinforcement beams below the floor, the floor may become deformed or may curve inwards. In such cases, lay a more than 12 mm thick board below the system to distribute the weight of the system on the floor.

For concrete floors, it may not be possible to install the system horizontally due to the roughness of the floor. In such cases, do the same as above.

When installing the system on a installation table, always place the screen unit and cabinet on the same level of the installation table. The screen should also be more than 15 mm inside the edges of the installation table.

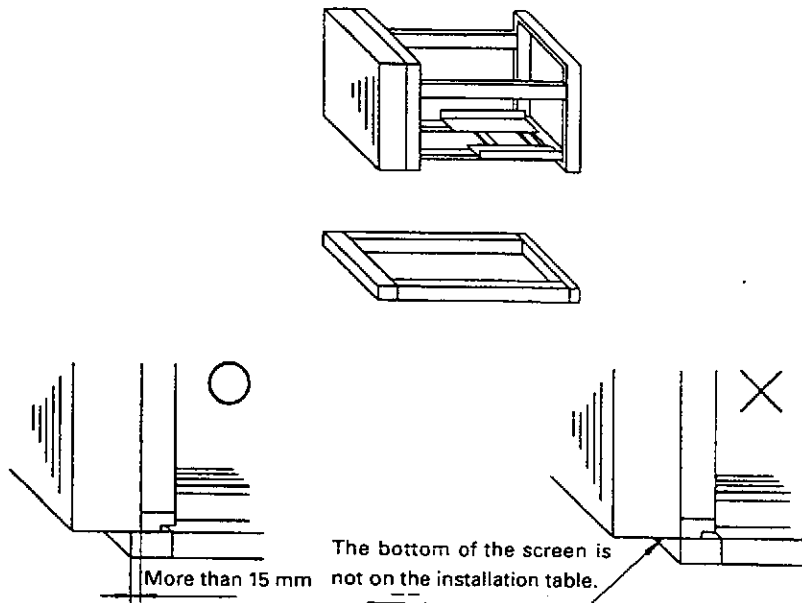

(Fig.3-1)

② How to calculate weight

Example : 40-inch Cube x 16screens

RM-V2400N (Multi-Projection Unit)	$38\text{kg} \times 16$	$= 608\text{kg}$
RMS-V4011 (Projection Screen Kit)	$11\text{kg} \times 16$	$= 176\text{kg}$
RMF-V4011 (Projection Frame)	$27\text{kg} \times 16$	$= 432\text{kg}$
RMS-V112 (Projectin Install Table)	$54\text{kg} \times 4$	$= 216\text{kg}$

Total : 1522 kg + α (screw, others)

*Note) Other than the above weights, the weight of the person installing the system are also added.
For 16 screens, about 3 to 4 persons=240 kg (15% of total weight).*

(2) Ceiling

- The distance from the top of the system to the ceiling must be about the length of one screwdriver (about 30cm).
The ceiling above the system has air-conditioner vents or light bulbs, take note that problems caused by dusts, temperature and humidity, and water droplets may result.

(3) Front Space

- Finger and hand prints form easily on the face of the screen. Therefore make sure viewers cannot touch it directly.
Also leave adequate space in front of the system so that the screen can be replaced and maintenance can be performed from the front.

(4) Rear Space

- When removing and installing the projection unit from the back, at least 1m must be left open at the back. When removing and installing from the front, leave a space of at least 70 cm so that wires and the control assembly can be pulled out.

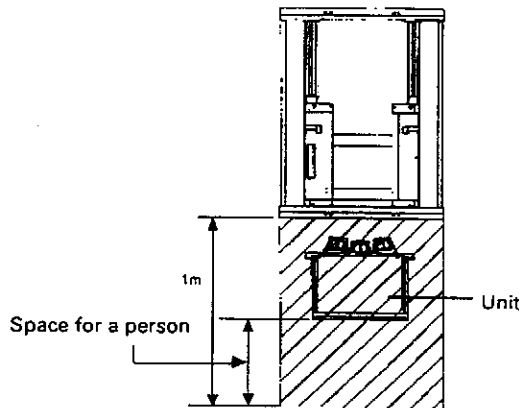

(Fig.3-2) View from the top

At installing locations where the projection unit has to be removed from the front, take note of how the unit is to be installed.(Refer to Chapter 3 4-(2)-④.)

(5) Number of Units Stacked Up

- Up to 4 to 5 units can be stacked up on top of each other. But do not use the casters of the installation table (RM-V112) for the 4th level and upwards.
- When stacking to the fourth level, the projection units can be supported by grounding all casters.
When using mounting tables, after installing, always secure the tables to the floor using the floor levelers attached to these tables.
- Use a reinforcement when stacking more than 5 units (from the 6th level).
Example 1 :Remove the casters, and place weights on the installation table to stabilize it.
2 :Secure using anchor bolts.
(Use chemical anchor bolts if possible.)
3 :Secure with wires.

(6) Prevention of Tilting

- The method of securing to floors and walls differ according to their materials. Always have a construction specialist or Pioneer dealer perform the procedure for you.

(7) Calculating the Heat Quantity

The maximum power consumption of each multi-projection unit is 300W. As most of the power consumed changes to heat, power consumed is taken to be the heat produced.

① Convert to calories

$[W] \times 0.86 = (\text{kcal/h})$

Heat produced/multi-projection unit

$300 \times 0.86 = 258 (\text{kcal/h})$

② Convert to B.t.u

$[W] \times 3.41 = [\text{B.t.u}]$

Heat produced/multi-projection unit

$300 \times 3.41 = 1023 [\text{B.t.u/h}]$

No. of Screens	Calories(kcal/h)	B.t.u/h
1	258	1023
4	1032	4092
9	2322	9207
12	3096	12276
16	4128	16368

(8) Temperature and Humidity

- Closely observe the following conditions on the temperature and humidity of the location of installation.
 - (1)Operating temperature : 5 to 35 degC (No condensation)
 - (2)Operating humidity : 20 % to 80 %
 - (3)Storing temperature : -10 to 45 degC
- The lenticular sheet will stretch and consequently the center of the screen will rise if the humidity is relatively high. In this case, the focus may slightly change and therefore readjustments in the installing conditions of the location must be performed when your system arrives.
- Avoid wetting the system at all times. Due to the shape of the product, it is easily affected by external conditions. Especially to be avoided is wetting the multi-projection unit and screen. Thorough water-proof measures must be taken when installing them in locations where there is a high level of moisture in the air such as near air-conditioning vents and water sprays.
 - * Take note that in new buildings, moisture is frequently produced from the concrete and the humidity level subsequently rises.
- Generally, electronic equipment such as the multi-projection unit should not be installed in high humidity environments. Follow the precautions below when high humidity is expected.
 - Never install the multi-projection unit and screen in locations that do not meet their respective specifications.
 - Ground the units.
 - Ensure that there is no condensation.
 - Install the units where no one can touch them.
 - Ensure that water droplets do not fall onto the units.

(9) Ventilation for system

The ventilation method differs according to where the system is installed. The following shows how to provide ventilation for the units according to the place of installation. Refer to these and keep the installation condition in the previous section [(8) Temperature and Humidity] at the system.

But when installing your unit, consult your dealer.

① When there are no walls on all sides (within 1m)

As shown in Fig. 3-3, attach the top panel, side panel, and rear panel.

(Note)

When attaching the rear panel, be careful not to block the vents for the fan of the projection unit.

② When there is a wall at the back *

As shown in Fig. 3-5, mount a large fan to the top panel, provide vents for inhaling air at the bottom panel to blow out air inside. Always leave more than 300 mm between the wall and the back of the unit.

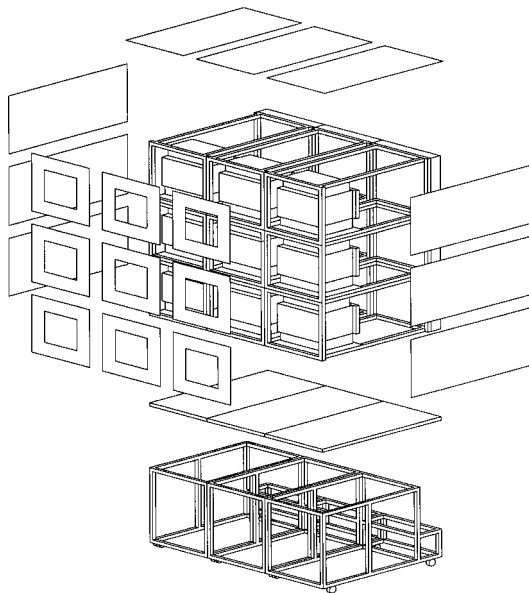

(Fig. 3-3)

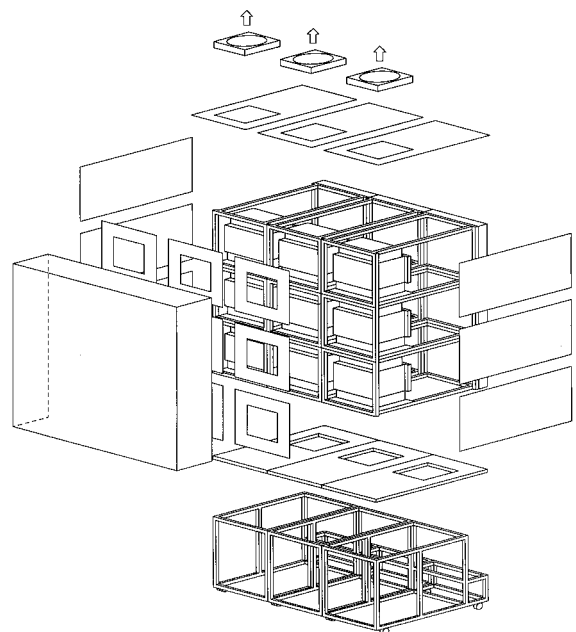

(Fig. 3-5)

③ When blocking the bottom (when placing the projection unit on the floor directly) *

Same as 1. (Fig. 3-6)

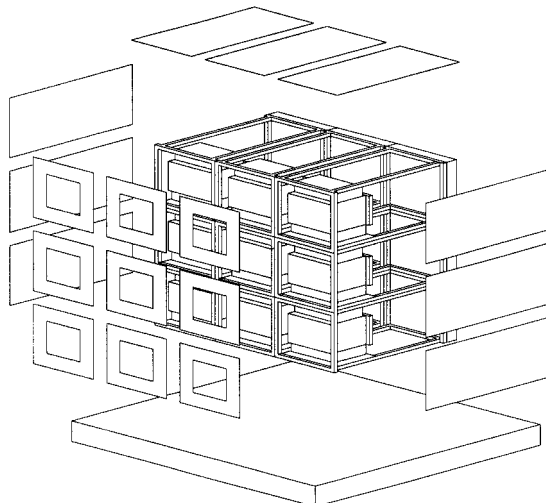

(Fig. 3-6)

<Note>

*: There should be no obstacles within the 1m area of the unit except for the rear and bottom. If this condition is not followed, construct your own ventilation system (large fan, low temperature by air-conditioning, etc.) according to the site of use.

(10) Condensation

One problem that occurs in the winter season is "Condensation". When the temperature of the room in which the multi-projection unit system is installed rises suddenly, condensation occurs on the screen and lens, thereby the system cannot display its best performance. In such cases, turn off the power once, leave the system off for one hour, and turn on the power again. Increasing the room temperature gradually is another method.

(11) Visible Angle

<Obtaining the Appropriate Visible Angle>

First decide the range actually viewed, and next decide the position of the projection system referring to the figure below.

Example) When installing 40-inch 16 screens at the 8m center in the range where the height is more than 3m while standing and more than 4m while seated.

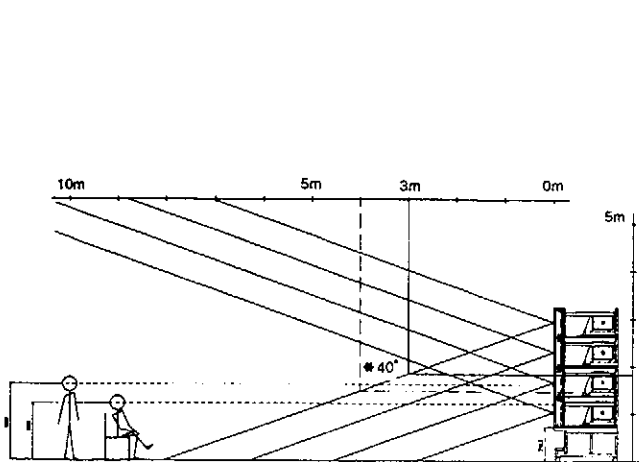

(Fig. 3-8)

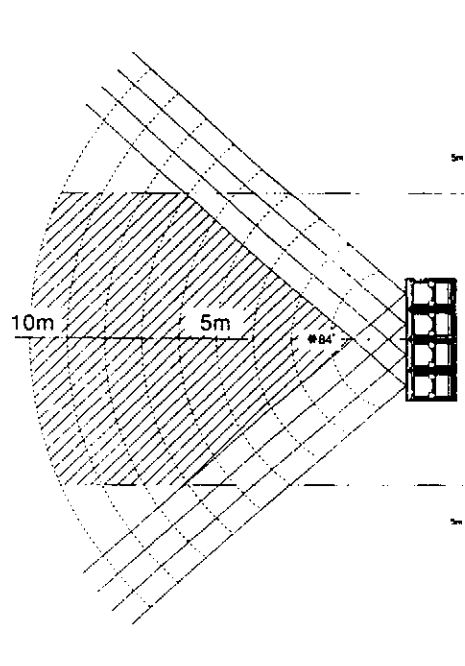

(Fig. 3-9)

* 40° (Vertical), 84° (Horizontal)

The vertical 40° and horizontal 84° position is the angle at which the luminance drops by 1/3 against the front. Pioneer recommends that the screen be positioned at this angle because images will not appear dark at this angle.

<Explanation>

The point of intersection of the line projecting down 3m from the screen and the lower line from the 4th projection system is approximately 1.8 m from the floor. (Black lines in Fig. 3-8.)

The point of intersection of the line projecting down 4m from the screen and the lower line from the 4th projection system is approximately 1.5 m from the floor. (Dotted lines in Fig. 3-8.)

To allow the user seated 4m away to view the screen (the eyes is fixed at 1.2m):

$$1.8 - 1.2 = 0.6 \text{ m} = 600 \text{ mm}$$

This means that as the bottom of the first projection unit to the floor is 716.5 mm, it needs to be placed 600mm below the current position without using the installation table RM-V112 or RMA-V5010.

As for as the standing position, the line projecting down 3m from the screen and the line from the 4th projection unit intersect at the following point:

$$1800 - 600 = 1200 \text{ mm} = 1.2 \text{ m}$$

As the position of the eyes is approximately 1.6 m high when standing, it can be covered sufficiently at 3 m from the screen. For the horizontal direction, the area shaded diagonally is the visible range when 4 m from the center as shown in Fig. 3-9.

40-inch Vertical Visible Angle

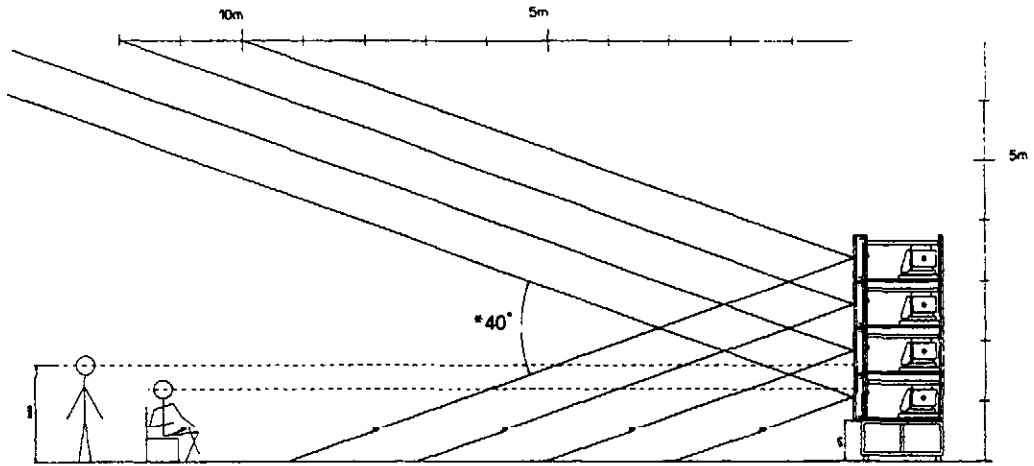

50-inch Vertical Visible Angle

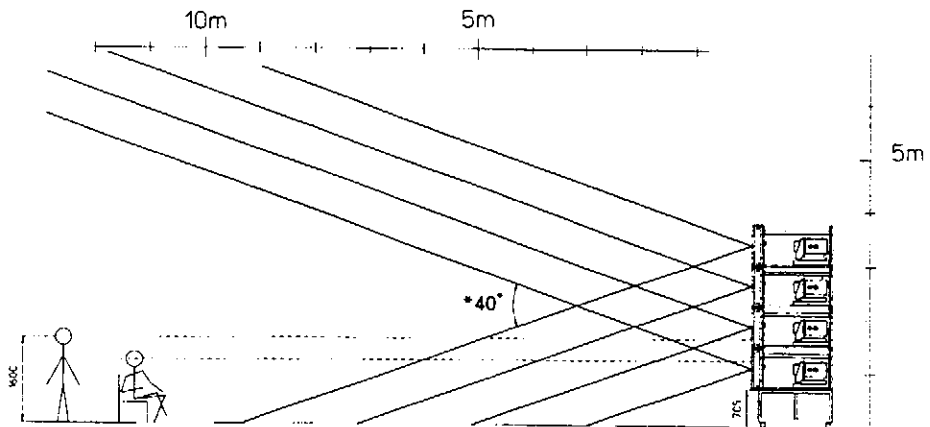

(Fig. 3-10)

40-inch Horizontal Visible Angle

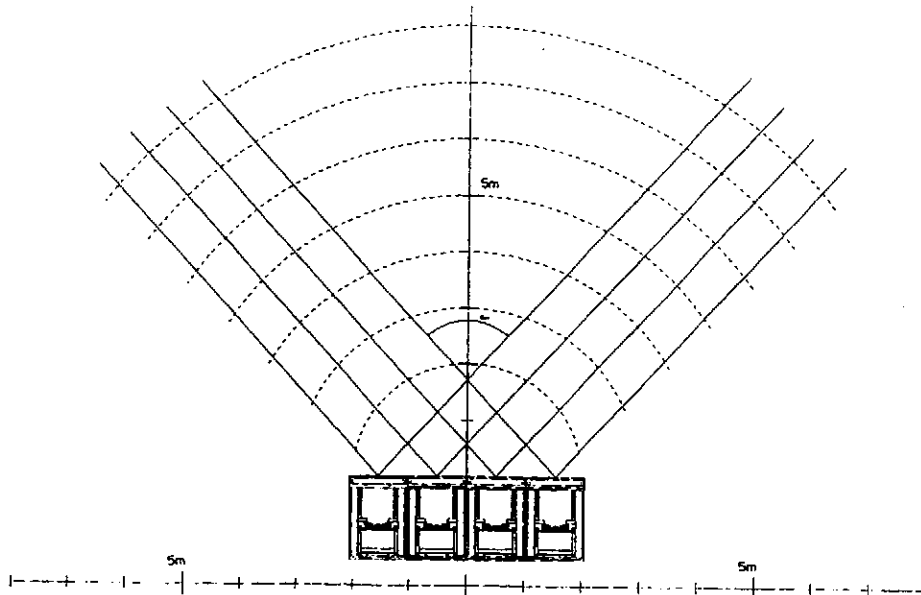

50-inch Horizontal Visible Angle

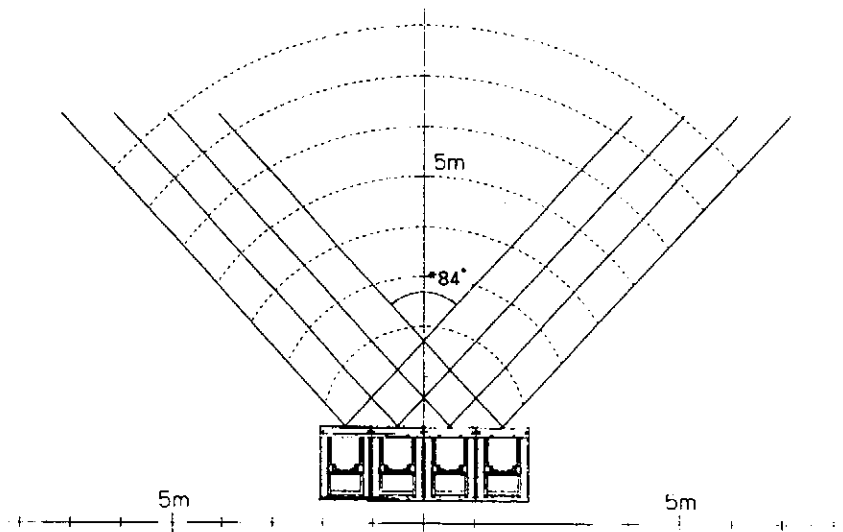

(Fig. 3-11)

(12) Lighting

- The projection screen kit (RMS-V4011/V5011) and the projection cabinet (RMF-V4011R / V4011CR) will not reflect like TV screens when exposed to external light, but may reflect if directly exposed to strong lights such as spotlight. Therefore, make sure that the screens are not exposed to direct spotlight.
- For certain installation location conditions, a glass sheet may have to be attached to the screen surface. In this case, as there will be reflection by external light, consider the installation position, etc. carefully.
- As the actual intended images of the system may not be obtained in very bright locations, consider the position of lighting and direction of sunlight when installing the system.

(13) Effects of Earth Magnetism

- Due to effects of earth magnetism, the position of the image displayed will differ according to the installed direction. Difference is about several mm in the up/down/left/right directions, but the degree of change varies according to the strength of the earth magnetism of each area. Misconvergence may also occur due to slight rotations. Therefore, when performing adjustments before bringing the system into the installing location. Perform the adjustments in the same direction and angle as installation, perform adjustments again at the final location decided.
- If the system is used at a fixed position, adjust it at the final position used.
- The system is not only affected by earth magnetism but by the following magnetisms generated by various items in its surrounding as well.
 - Steel frame of building
 - Power cables on the floor
 - Large speaker systems
 - Special equipment (Those generating magnetic force)
 - Metallic installation table, frames, etc.

(14) Connection with a Power Supply ⚠

① Power supply voltage

The guaranteed voltage of this unit is $\pm 10\%$ of the rated voltage.

But if the impedance of the power wires is high, the voltage waveform will become distorted and show the same symptoms as when voltage drops abnormally. As the following must be noted even if the voltage is within the allowable range, check the power wiring again.

- The voltage drop from the distributor to the multi projection unit is great.
- The voltage changes greatly when the power of the unit is turned on and off (Roughly 5% of the rated voltage)

② Power supply capacity

Calculate the power consumption of one unit as 400VA with allowance.

Multi-Projection Unit Screens	Power Supply Capacity	Current Capacity			
		RM-V2400NA / V2500NA		RM-V2400NE / V2500NE	
		100V	120V	220V	240V
1 screen	400VA	4 A	3.3 A	1.8A	1.7A
4 screens	1600VA	16 A	13.3 A	7.3A	6.7A
9 screens	3600VA	36 A	30.0 A	16.4A	15A
12 screens	4800VA	48 A	40.0 A	21.8A	20A
16 screens	6400VA	64 A	53.3 A	29.1A	26.7A

The current increases when the voltage decreases. Referring to "③ Connection", design the system slightly greater than the above figures. When connecting the distributor to other equipment, also take note of the power consumption of the equipment and make sure the capacity of the distributor is not exceeded.

③ Connection

- An AC OUTLET is provided on the unit. Up to two multi-projection units can be connected to a multi-projection unit. Do not connect other types of equipment.

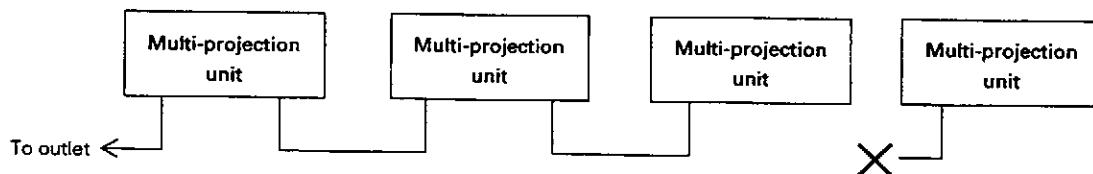

- Connect the equipment so that the current capacity of the distributor is not exceeded. Set slightly greater.

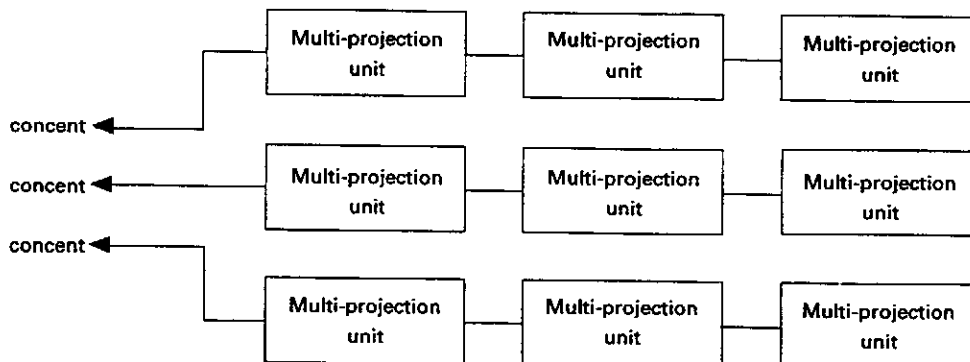

④ 3P Plug

The power cord of this unit has a 3P plug. This is to prevent electric shocks caused by leaked currents. Always connect it to a 3P outlet.

⑤ Leak Breaker

The unit is incorporated with the power line filter to reduce noise. Therefore a 0.5 mA leakage current will flow with each unit. If a leak breaker is equipped, check that its sensitive level is above the total leakage current of the system.

Also calculate each unit such as image transmission unit, etc. as 0.5 mA.

It is extremely dangerous to supply power from existing wall outlets, etc.

Position the final outlet connected to each unit of this system as near as possible to the system.

Set the current capacity slightly greater-about more than 25% of the total consumption power.

(15) Cables Used

Use coaxial cables. Normally use a 3C-2V for less than 20m long. Use 5C-2V for greater lengths. 5C-2V is recommended for high-vision.

Adjust the length of the cables. The distance between the transmission system and multi-projection unit should be as short as possible. When the distance is great, consider the thickness of the cable and electrical compensation carefully.

The limit is as shown when using the cables to connect the transmission final output terminal and the system.

3C-2V: 15m

5C-2V: 30m

To use a longer cable, the VIDEO signal must be corrected.

(16) Semi-outdoor Installation

This system is basically designed for use indoors. However, if it has to be installed outdoors, take note of the following.

- Waterproof and rustproof measures
- Temperature difference and humidity difference
- Light on the screen (So that it is not exposed to direct sunlight.)
- Wind containing salt

(17) Precautions for Use of User-Obtained Parts

It is recommended that Pioneer products be used for the projection stand, mount unit, etc. Users obtaining these parts separately by themselves should take note of the following.

- When obtaining stands and mount units separately, make sure that the system can be installed horizontally. Also calculate strength properly and take adequate measures against tilting of the screen. If the recommended stand and mount unit are not used, Pioneer will bear no responsibility whatsoever for accidents and injuries incurred due to incomplete connections and mounting, natural disasters, etc.
- When mounting top board, side board, rear panel obtained separately, use the holes for mounting the Pioneer stand and projection frame. (Refer to Fig. 3-39)

2. INSTALLATION AND ASSEMBLY

(1) Confirmation

① Decide the position for installing the system according to the installation conditions in Chapter 3.

Check Items

- [1] Dimensions of installing position, space at the back, distance to the ceiling
- [2] Floor flatness, strength, roughness
- [3] Position of power supply
- [4] Installing location

Necessity to strengthen the floor, wall, etc.(reinforcement cover, sheet, plank, etc.), path used to transport the system, width of passage, if elevator is available, its size and maximum bearing weight, etc.

- [5] Position, specifications, and structure of a transmission equipment, and image type
- [6] Model number of equipment used, and their quantity (perform according to list).

Check if there is enough equipment for each unit

*These procedures must be performed by only one person.

(2) Opening the Packaging

① Packaging specifications

[1] Multi Projection Unit	(RM-V2400N/V2500N) : 770(W) × 630(H) × 670(D)	43.5kg
[2] Projection Screen Kit	(RMS-V4011) : 940(W) × 230(H) × 730(D)	15.7kg
	(RMS-V5011) : 1126(W) × 230(H) × 879(D)	20.2kg
[3] Projection Frame	(RMF-V4011) : 950(W) × 180(H) × 1300(D)	31.2kg
	(RMF-V5011) : 1160(W) × 250(H) × 1475(D)	35.4kg
[4] Projection Cabinet	(RMF-V4011R) : 1006(W) × 859(H) × 1454(D)	68.0kg
	(RMF-V4011CR) : 1007(W) × 867(H) × 1393(D)	58.0kg

② Opening the packaging

Open from the big ones first and put the small packagings inside the empty big packagings. Also dispose or store the packagings.

Do not mix up the opened items with those still in the packaging.

Move the empty packagings somewhere else so that they will not come in the way. Next, obtain an assembly space that is as wide as possible.

* Turn down the opened packagings upside down to differentiate them from those not opened.

Do not lose accessories, the warranty card, etc.

③ Multi Projection Unit (RM-V2400N/V2500N)

[1] Open the upper carton.

[2] Remove the upper carton.

[3] Remove the upper pad and remove the AC power cord, ABL cable and instruction manual provided.

[4] Take out the unit (must be taken out by two persons).

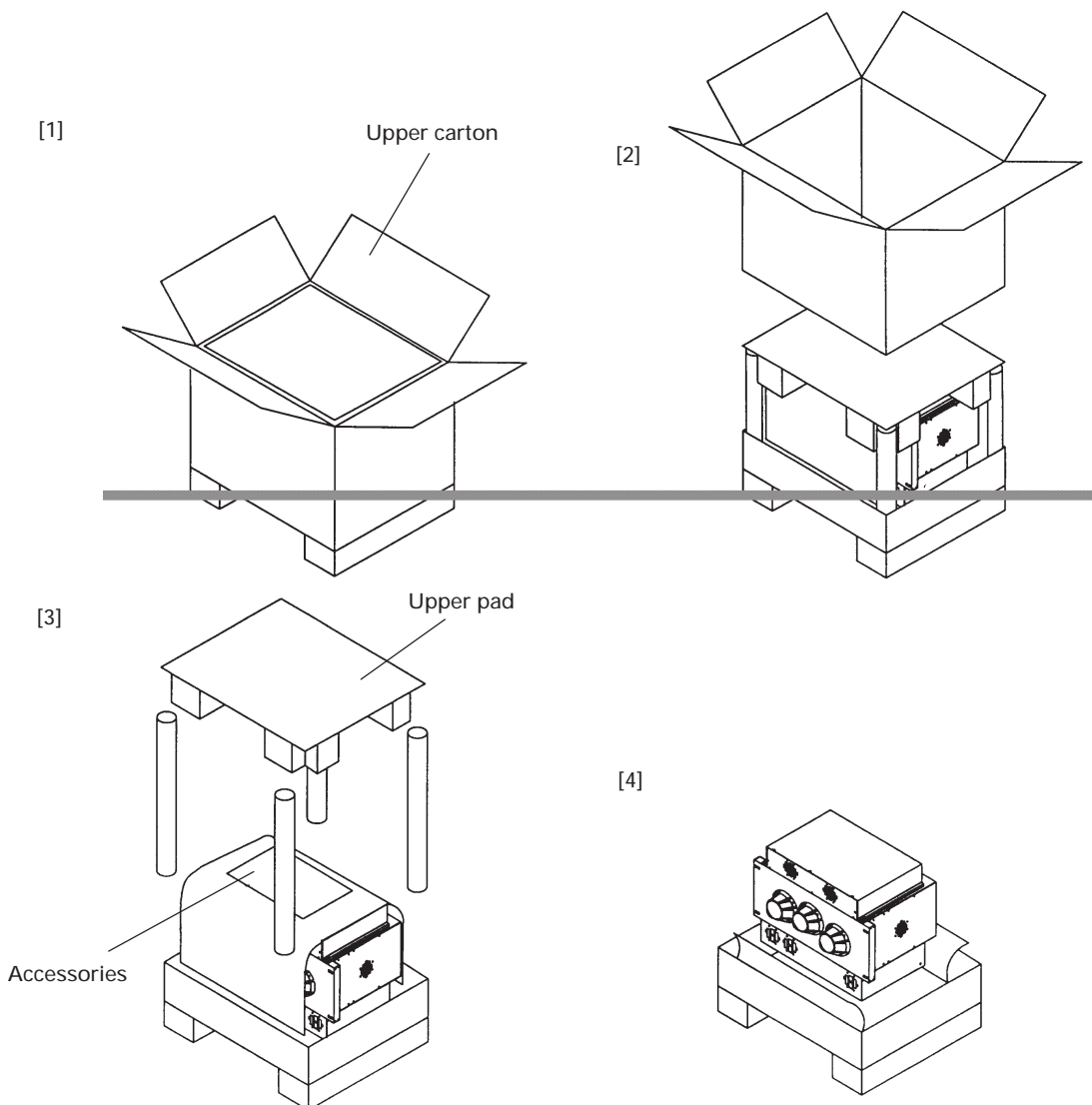

(Fig.3-12)

④ **Projection Screen Kit (RMS-V4011/V5011)**

* Projection screen kit is double-packaged to maintain its performance. After removing the middle cover protecting its screen, make sure the screen does not get scratched or dirty.

- [1] Remove the top cover.
- [2] Remove the band securing the middle cover and remove the middle cover.
- [3] Gently peel off the black tape pasted at the four sides of the screen.
Be careful not to damage the lenticular sheet.
- [4] Take out the screen unit from the box and stand it on a flat floor, paying attention to its top and bottom.
- [5] Remove the eight screws for transportation (gold), four protection panels, white sheet at the back of the screen, and the bag containing accessories attached to the top of the frame.
* The protection panel is attached with the transportation screws. Keep the removed panel if required. When storing the system, do not remove the outermost protection panel.
- [6] When opening the packagings of several units first, after opening them, place them in a different place to protect them from damage, and place a sheet over them to protect them from dusts.

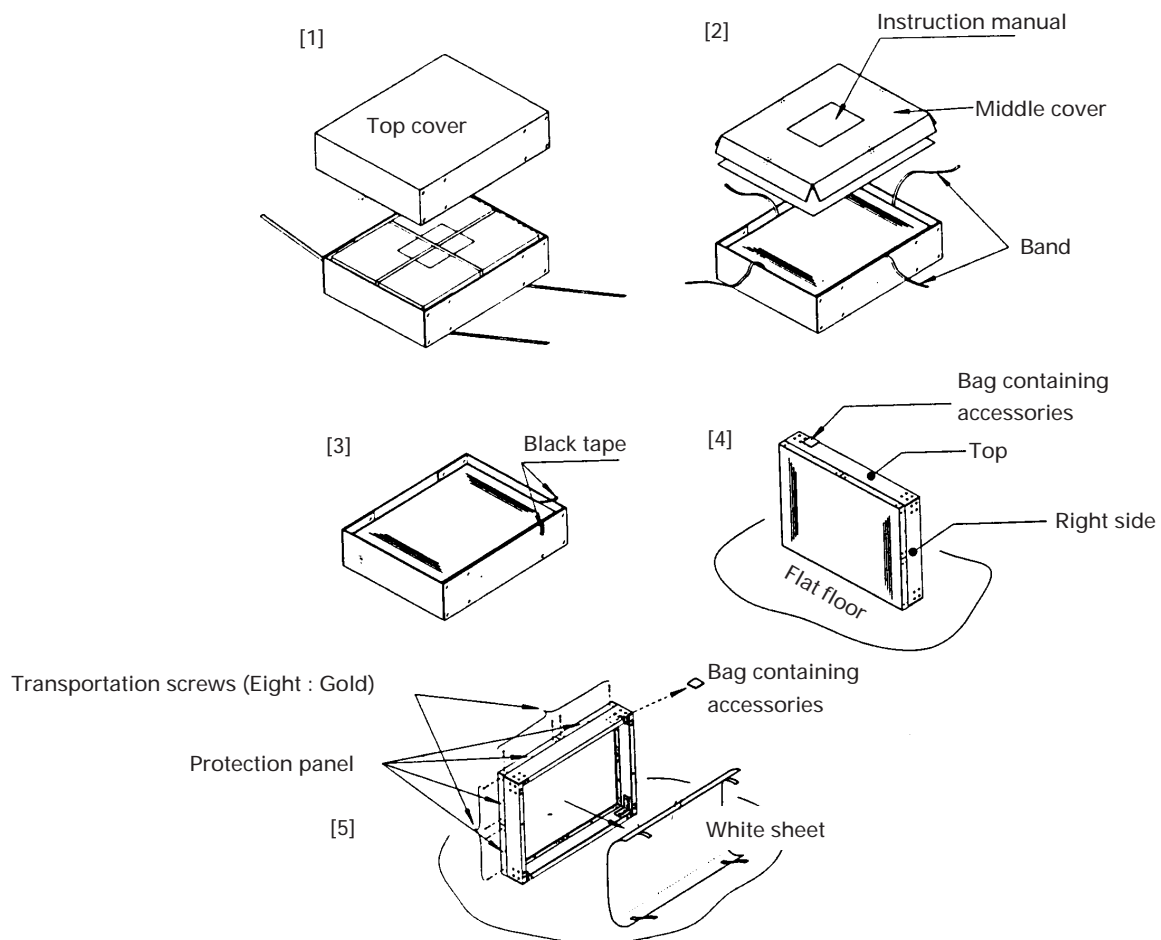

(Fig.3-13)

⑤ **Projection Frame (RMF-V4011/V5011)**

- [1] Open the upper carton and cut the PP bands (eight) securing the internal parts.
- [2] Remove the two horizontal frame assemblies (packaged in a card box), fixtures (R) and (L).
- [3] Remove the H-shape frame assembly (L).
- [4] Remove the base assembly.
- [5] Remove the H-shape frame assembly (R).
- [6] Remove the shield attached to the under carton, bag containing accessories, and instruction manual.

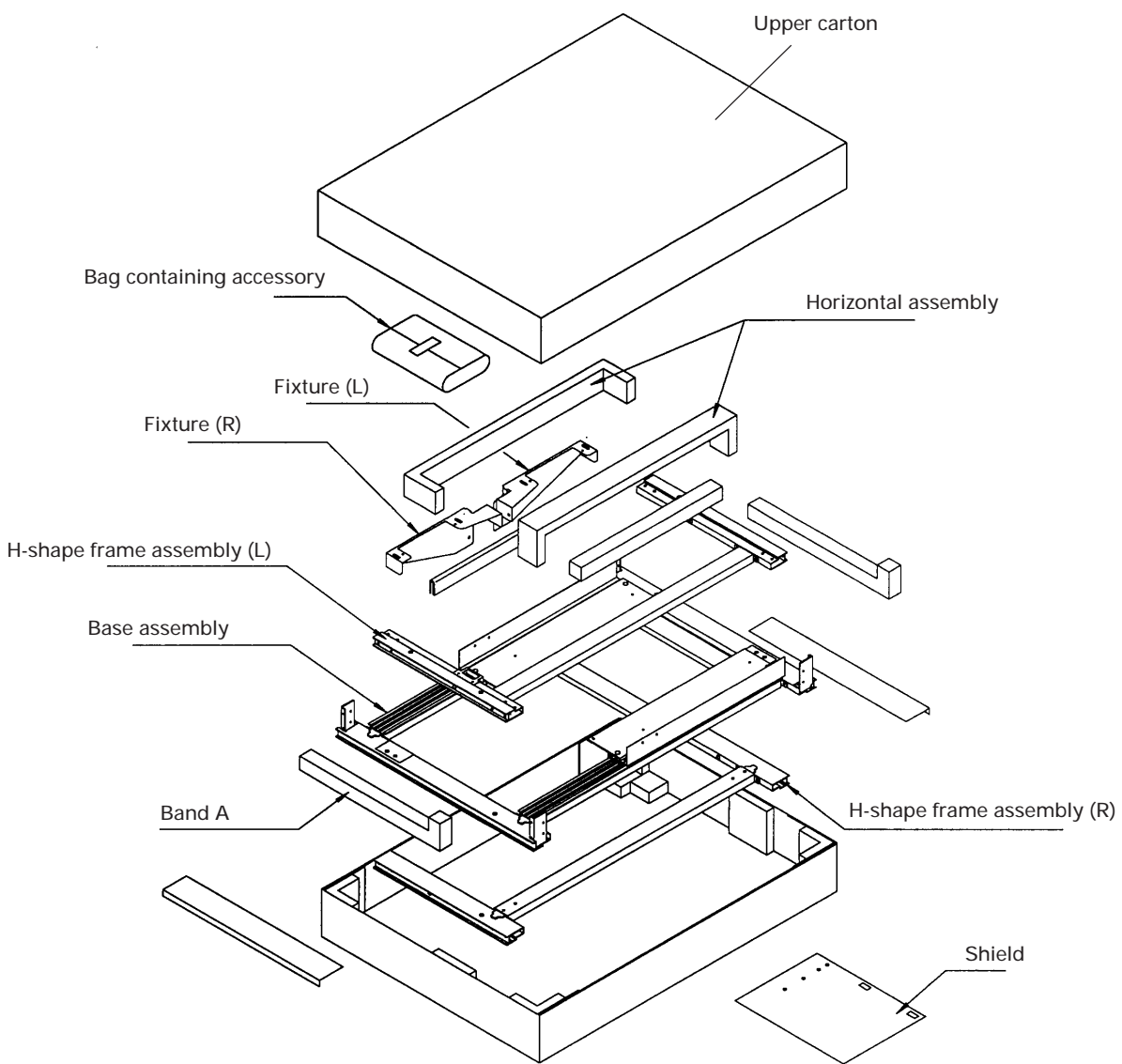

(Fig. 3-14)

⑥ Projection Cabinet (RMF-V4011R)

- [1] Open the upper carton and remove packings B and C, and the instruction manual.
- [2] Remove the upper carton.
- [3] Remove the top sheet B and peel off the front and back sheets B.
- [4] Remove the cabinet. (Hold the handle of the cabinet by two persons.)
- [5] Remove sheet B.
- [6] Remove the parts from the under carton.

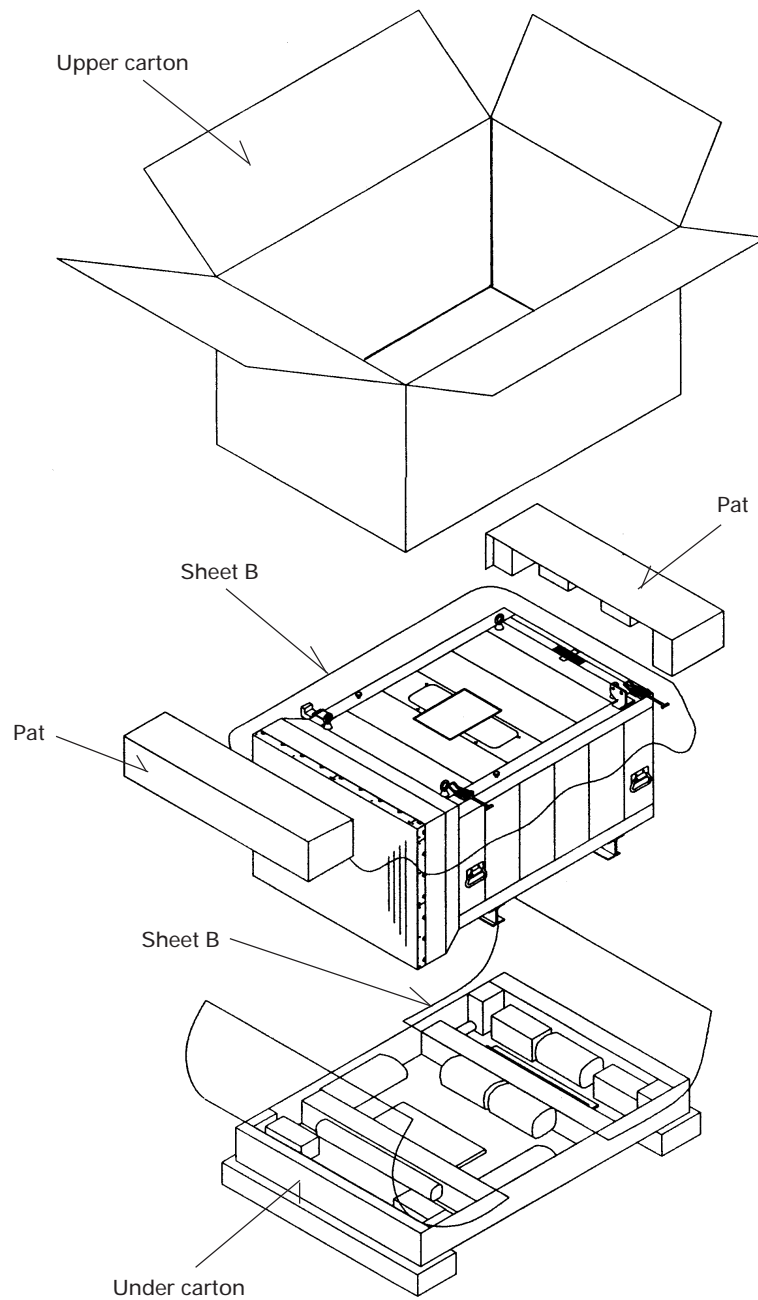

(Fig. 3-15)

⑦ **Projection Cabinet (RMF-V4011CR)**

- [1] Open the upper carton and take out pats A and B and the Instruction Manual.
- [2] Remove the upper carton.
- [3] Remove the upper sheet.
- [4] Take out the cabinet.
(This should always be performed by two persons holding the handle. As the front of the cabinet is heavy, be careful not to scratch the screen when taking it out.)
- [5] Remove the lower sheet.
- [6] Remove the parts from the under carton.

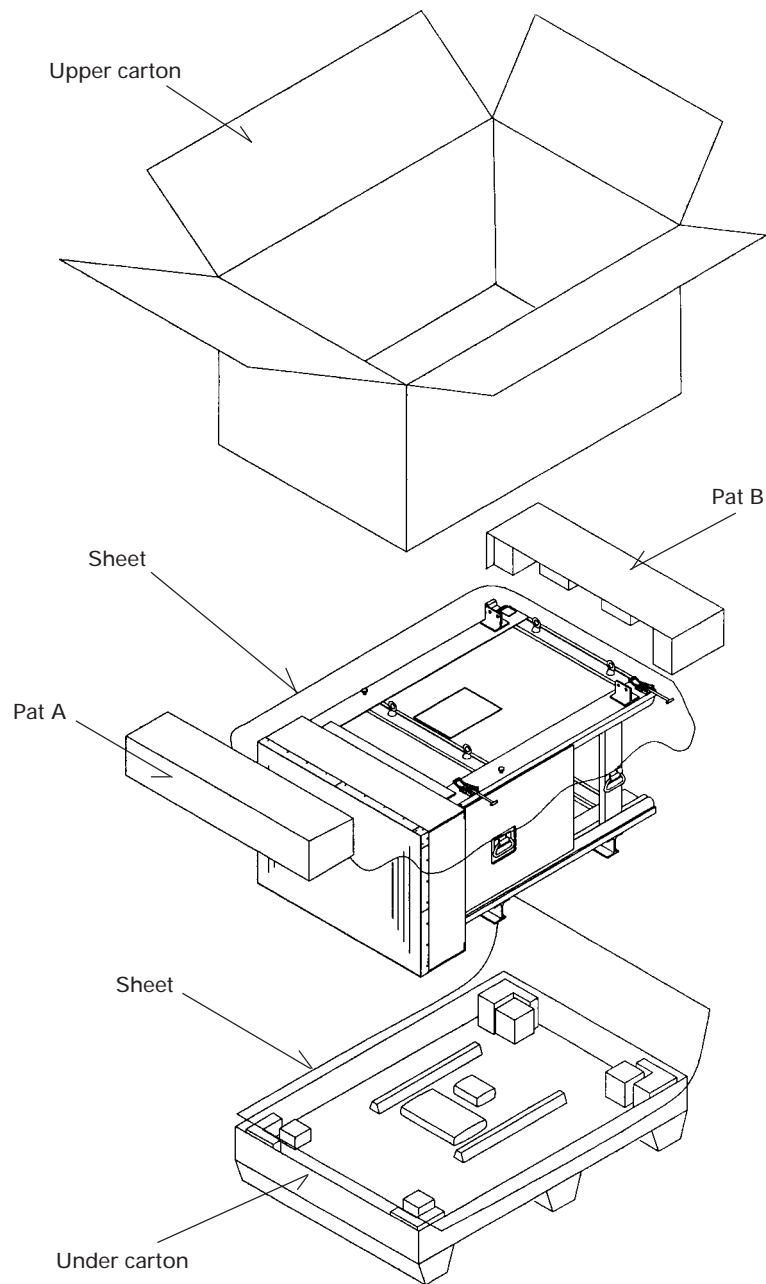

(Fig. 3-16)

(3) Carrying the Units After Opening Packaging

To carry the screen unit and multi-projection unit after opening the packaging, hold them by the parts shown in the figure, and lift and move them.

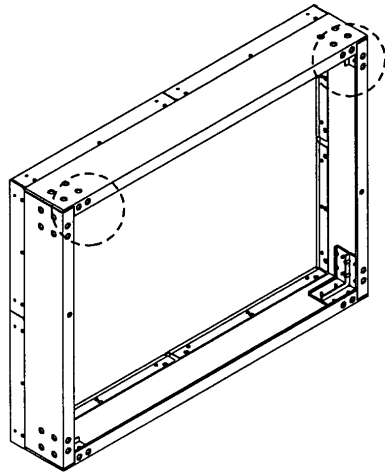

Screen Unit
(Lifted by one or two persons)

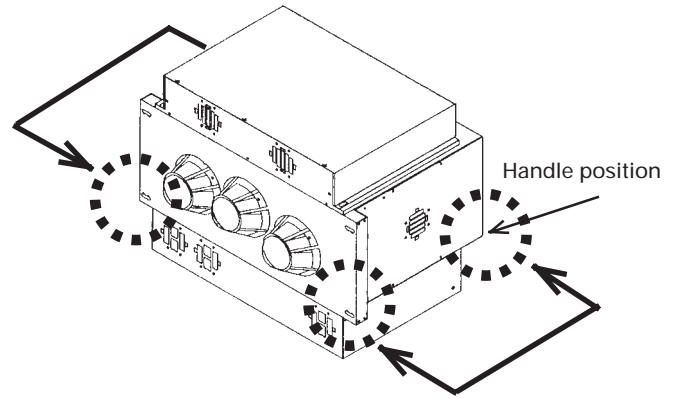

Multi-Projection Unit
(Must be lifted by two persons)

Hold the parts indicated by 

(Fig. 3-17)

- Never drag the system along the floor when moving the units.
- The lenticular sheet damages very easily as it is very thin. Therefore move it gently and do not apply excessive shock or vibration to it.
- As the panels supporting the screen are very thin and deform easily, be careful that they do not hit or get hooked onto surrounding objects when moving them.

② Mount Unit (RMA-V2050/V2060)

Place the mount unit on the stand and join them using the specified bolts and nuts.
 As the horizontality, difference in level, etc. of the mount units form the basis of the whole system assembled, assemble them accurately.
 If gaps are formed between the mount unit and the stand due to the difference in height, use the floor leveler of the stand to adjust the height, or place spacers between the mount unit and stand (metal plates about 1 to 2 mm thick).
 When using several mount units, adjust their height, horizontality, etc.
 In the case of the system for rental-use, mount the conventional mount units (RMA-V2050/V2060) using the conventional method. For details, refer to the RM-V2000A technical manual.

③ Projection Frame(RMF-V4011/V5011)

Assemble the frames from the bottom. (Assembling them vertically will make it difficult to adjust their left and right positions.)(Fig. 3-23, 24)
 Position them while aligning their front and back sides.
 (Fig.3-25)

From the second level, the stopper pins will go into the units below as the cabinet approach these units and the position is fixed.
 Next, adjust the front/back/left/right positions to the units below, and tighten the hexagon head bolts in the vertical and horizontal directions.

⚠ During the above procedure, the table holding the projection units will not be secure.
 Take note that as a result, the table may project out when the cabinet is tilted.

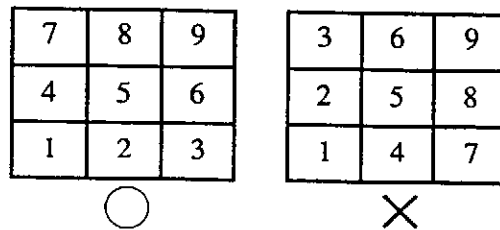

(Fig. 3-23)

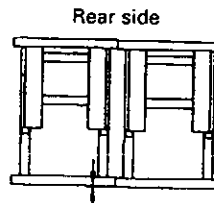

Adjust it with the front as a reference.
 (Fig. 3-24)

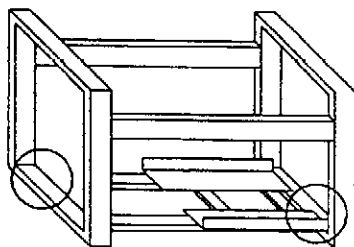

(Fig. 3-25)

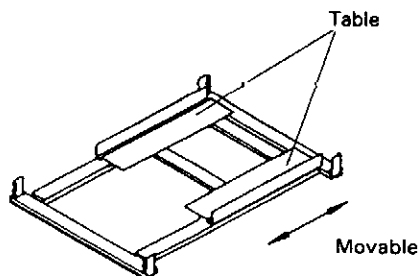

(Fig. 3-26)

4. ASSEMBLING THE SYSTEM

(1) Assembling the Projection Frame (RMF-V4011/V5011)

Assemble the projection frame as follows.

- [1] Mount the stopper onto the base assembly and tighten the screws (M5 × 35). (2 × 2 points)
- [2] Mount the H-shape frame assemblies (R) and (L), and tighten the screws (M5 × 10). (4 × 4 points)
- [3] Mount the horizontal frame assemblies (two) and tighten the screws (M5 × 10). (4 × 4 points)
 - * As for the positions for tightening the screws in steps [2] and [3], push the frame against the corner fixtures in the two directions indicated by the arrow.
- [4] Attach the shield to the H-shaped frame assembly (L) using rivet, and paste the magic tape on the H-shaped frame assembly (L) according to the magic tape pasted on the shield.
- [5] Attach the fixtures (R) and (L) and tighten the screws (M5 × 10). (3 × 2 points)
- [6] Place the projection unit on the base assembly, and secure the fixtures (R) and (L) and projection unit to each other with the screws (M5 × 10). (2 × 2 points)
- [7] Secure the movable part of the base assembly with the two screws (M5 × 35).

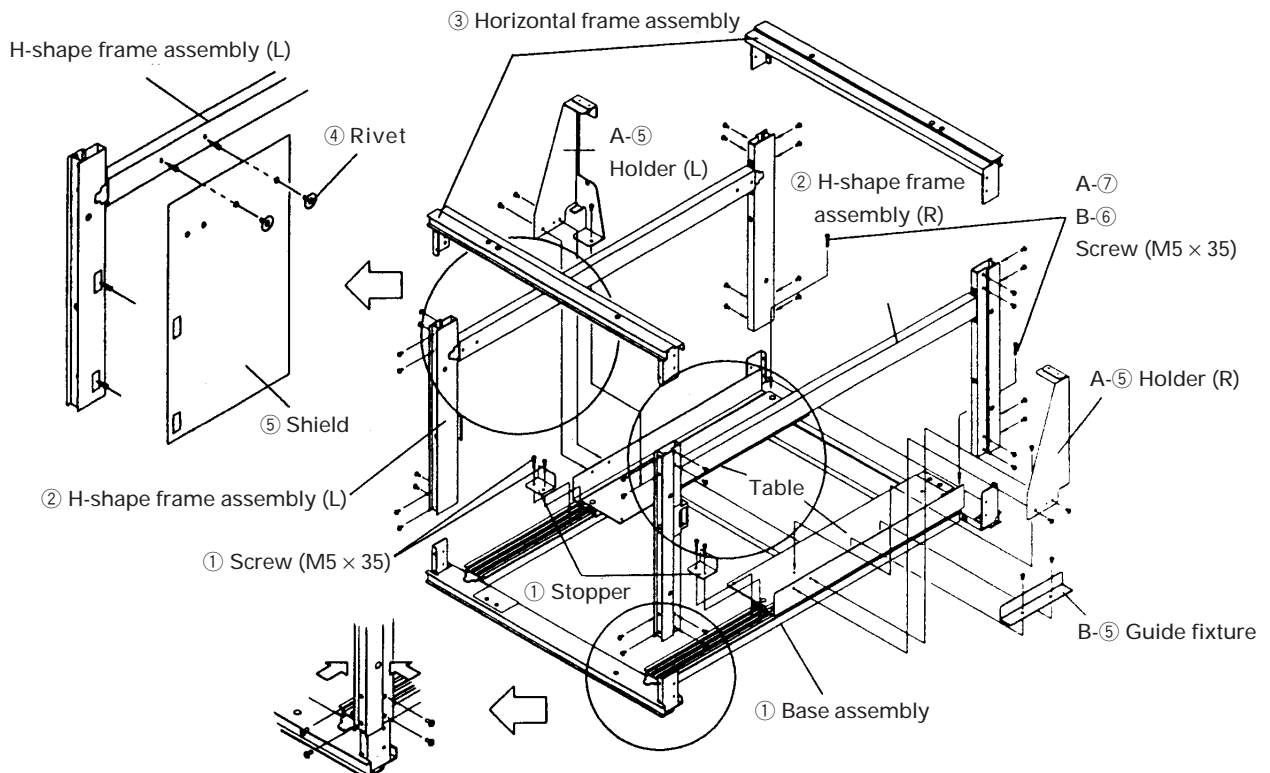

(Fig. 3-19)

(2) Assembling the System

The basic procedure for assembling the system is as follows.

- ① Assemble the projection install table (RM-V112/RMA-V5010).
- ② Mount a one-link mount unit . (40-inch only)
- ③ Assemble the projection frame (RMF-V4011/V5011). (Refer to Fig. 3-20)
- ④ Mount the multi-projection unit (RM-V2400N/V2500N).
- ⑤ Mount the projection screen kit (RMS-V4011/V5011). (Refer to Fig. 3-21, 22)
- ⑥ Mount the top board , side board , rear panel.
- ⑦ Mount the projection unit (RM-V2400N) to the projection cabinet (RMF-V4011R).

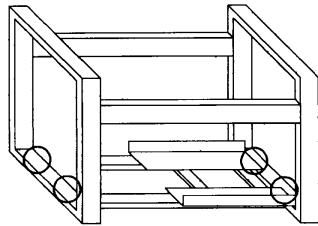

Mount the frame on the install table by 4 screws.
(Fig. 3-20 50 inch)

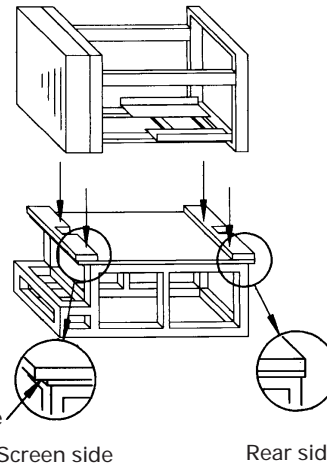

Screen side has the difference between the board and frame.
(Fig. 3-21 40 inch)

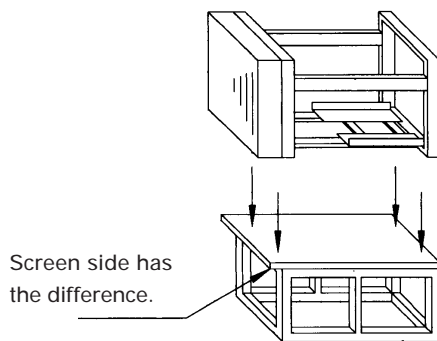

(Fig. 3-22 50 inch)

The basic procedure for assembling the system for rental-use is as follows.

- ① Assemble the projection stand (RM-V112).
- ② Mount the 2-link/3-link mount unit (RMA-V2050/V2060).
- ③' Mount the multi-projection unit (RM-V2400N) to the projection cabinet (RMF-V4011R/V4011CR).
- ④' Mount the projection cabinet (RMF-V4011R/V4011CR).
- ⑦' Mount the projection unit (RM-V2400N) to the projection cabinet (RMF-V4011CR).

The above procedure is recommended. It is explained below.

① Projection Install Tables (RM-V112/RMA-V5010)

Place the installation tables (RM-V112/RMA-V5010) at the specified position and link them together with the bolts and nuts specified.

First tighten the bolts and nuts temporarily, and after all have been linked, check their height differences and if they are horizontal before tightening the nuts and bolts firmly.

Do not tighten the adjusters at the legs as their final positions have to be adjusted after assembling all units.

To install at a height greater than the installation table when not using this table, make sure the strength is greater than required.

② Mount Unit (RMA-V2050/V2060)

Place the mount unit on the stand and join them using the specified bolts and nuts.
 As the horizontality, difference in level, etc. of the mount units form the basis of the whole system assembled, assemble them accurately.
 If gaps are formed between the mount unit and the stand due to the difference in height, use the floor leveler of the stand to adjust the height, or place spacers between the mount unit and stand (metal plates about 1 to 2 mm thick).
 When using several mount units, adjust their height, horizontality, etc.
 In the case of the system for rental-use, mount the conventional mount units (RMA-V2050/V2060) using the conventional method. For details, refer to the RM-V2000A technical manual.

③ Projection Frame(RMF-V4011/V5011)

Assemble the frames from the bottom. (Assembling them vertically will make it difficult to adjust their left and right positions.)(Fig. 3-23, 24)
 Position them while aligning their front and back sides. (Fig.3-25)

From the second level, the stopper pins will go into the units below as the cabinet approach these units and the position is fixed.
 Next, adjust the front/back/left/right positions to the units below, and tighten the hexagon head bolts in the vertical and horizontal directions.

⚠ During the above procedure, the table holding the projection units will not be secure.
 Take note that as a result, the table may project out when the cabinet is tilted.

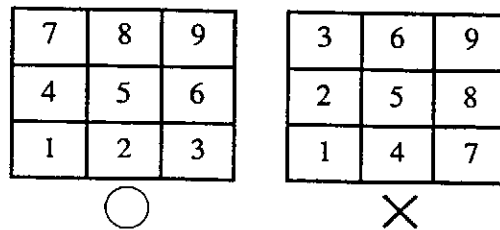

(Fig. 3-23)

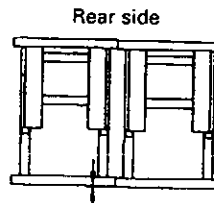

Adjust it with the front as a reference.

(Fig. 3-24)

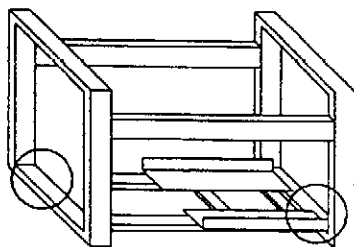

(Fig. 3-25)

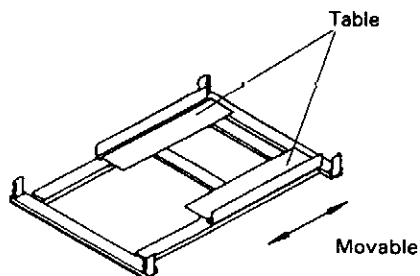

(Fig. 3-26)

④ Multi Projection Unit (RM-V2400N/V2500N)

The Multi-Projection Unit is designed to be mounted from the back of the cabinet normally. If sufficient space cannot be left at the back, it can be mounted from the front.

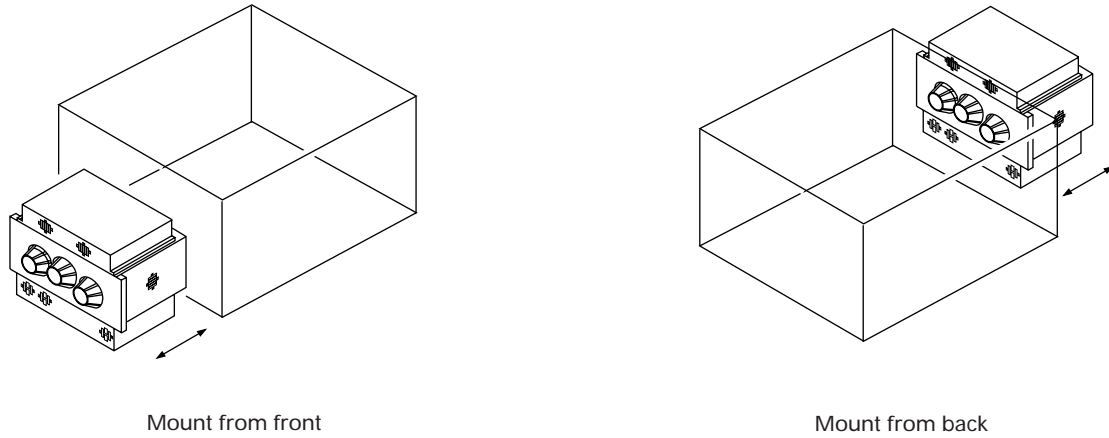

Mount from front

Mount from back

(Fig.3-27)

ⓐ When mounting from the back

[1] Pull the table of the cabinet to the back. (Fig. 3-28)

[2] Insert the (M5 × 35) into the holes (Fig. 3-29) on the table. (To prevent the table from moving when placing the projection unit.)

[3] Place the multi-projection unit on the table and decide the position.

The position should be so that the front of the multi-projection unit will touch the metal fixtures while the sides touch the guide fixtures (right side as viewed from the screen side). (Fig. 3-30)

[4] Secure the multi-projection unit to the metal fixtures of the cabinet with the four (M5 × 50). (Fig. 3-31)

[5] Remove the inserted into the table at step [2], and push in until the table touches the stopper.

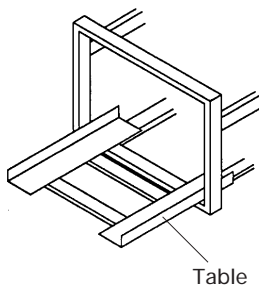

(Fig. 3-28)

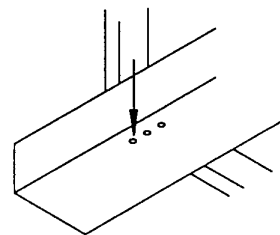

(Fig. 3-29)

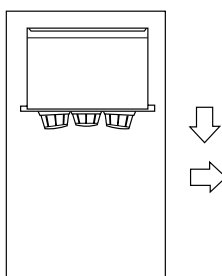

(Fig. 3-30)

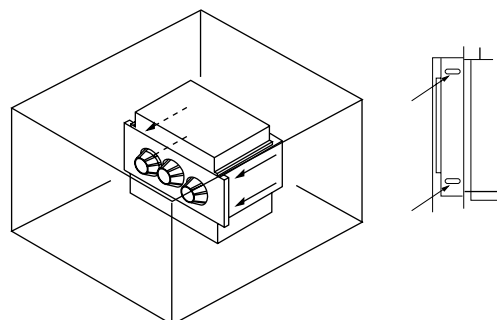

(Fig. 3-31)

⑥ When mounting from the front

- [1] Remove the two stoppers and two metal fixtures from the cabinet. (Fig. 3-32)
- [2] Pull the table to the front.
- [3] Insert the screws (M5 × 35) into the holes on the table.
- [4] Place the multi-projection unit on the table.
- [5] Attach the metal fixtures to the table.
- [6] Decide the position of the multi-projection unit and attach it to the metal fixture with the four (M5 × 10). (Fig. 3-33)
- [7] Remove the screws inserted into the table at step [3], and push in until the stopper can be attached.
*As there are no stoppers at the back, be careful not to push the table in excessively.
- [8] Re-tighten the stopper at the initial position.
- [9] Pull out the table until it touches the stopper.
- [10] Secure the cabinet table to the cabinet with the two (M5 × 35).

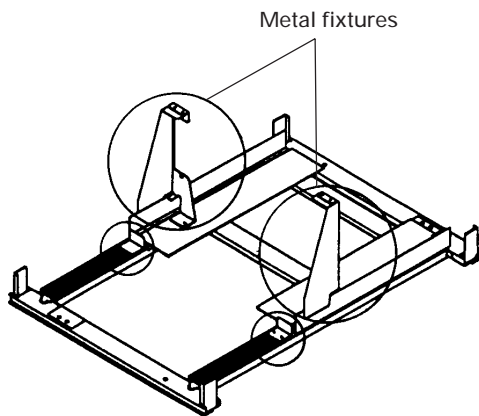

(Fig.3-32)

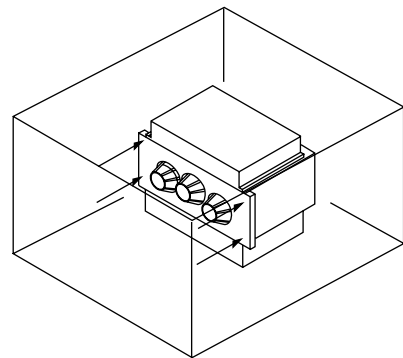

(Fig.3-33)

⑤ **Projection Screen Kit (RMS-V4011/V5011)**

[1] Mount the screen unit serving as the reference. Basically, mount from the center unit at the bottom.

Ⓐ **If the number of units arranged are odd (E.g.: 3 × 3=9 screens)**

- Adjust the screen unit to the cabinet at the center of the bottom level and temporarily tighten the linking bolts. (Do not tighten tightly.)
- Adjust the left and right balance with your hand and tighten the linking bolts tightly so that the two centers coincide.

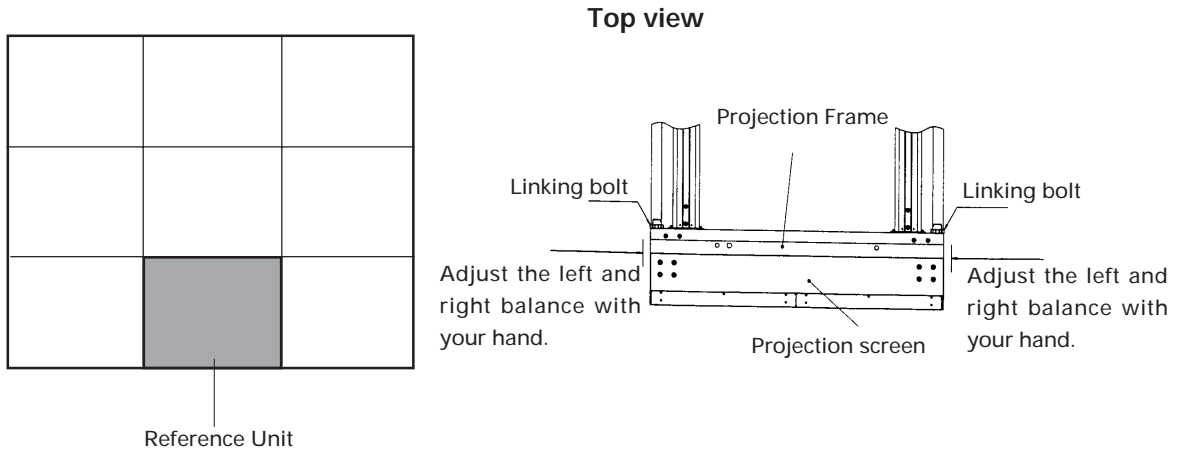

(Fig. 3-34)

Ⓑ **If the number of units arranged are even (E.g.: 4 × 4=16 screens)**

- Adjust the screen unit to the right cabinet (or left cabinet) at the center two cabinets of the bottom level and temporarily tighten the linking bolts. (Do not tighten tightly.)
- Adjust the left side of the screen unit attached and left side of the cabinet (rights sides if the screen unit was attached to the left cabinet at the center) so that they are aligned precisely with your hand, and tighten the linking bolts.
- Join the left side (or right side) screen unit to the unit mounted first as closely as possible.

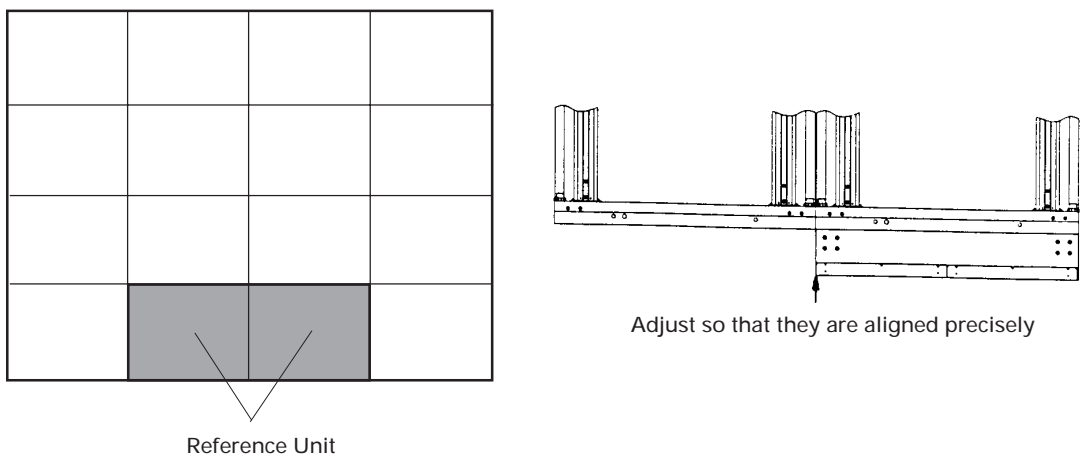

(Fig.3-35)

- [2] Join the next screen beside the screen mounted as the reference and mount the remaining screens in order. (Stack them from the bottom to the top.)
- [3] If necessary, attach the screw rivet (BEC1082) provided as the accessory of RMS-V4011. (Fig. 3-36)

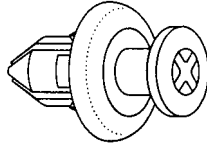

(Fig. 3-36)

- * This part is used to shield the light leaking from the big hole (ø 8) on the outermost side of the left and bottom projection units (diagonally shaded part in Fig. 3-37) after installing the system. Use it if necessary. Screen units with this rivet cannot be attached outside the area indicated by the standing lines in fig. 3-37. (It will not connect to the adjoining units.)

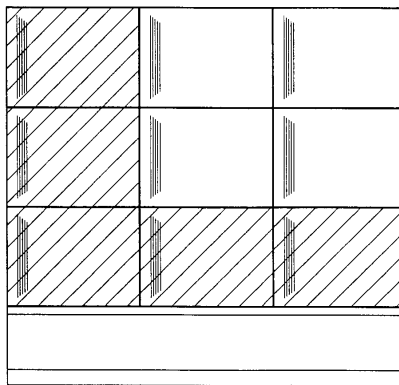

(Fig. 3-37)

<Note>

- Do not mistake the top and bottom of the screen unit. The side with the longer screw projecting out (side with transportation screw) is the top and the side with the 8 mm hole is the bottom.
- Before mounting the screen unit to the cabinet, check that the transportation screw, protection panel, and black tape have been removed. (Do not remove the protection panel on the outer-most side when installing the system.)
- Always tighten the linking bolts of the cabinet and screen unit with your hands, and tighten them as firmly as possible.
- Put on gloves when stacking the screen units for protection and perform in twos.
- To prevent the lenticular sheet from damage, mount the screen unit gently and do not subject it to vibration and shock.
- When the screen units are stacked, the head of the panel fixing screws and 8 mm holes will engage. When stacking the upper screen unit, make sure that it does not brush the lower screen unit as it has panel screws projecting out.

⑥ **Top panel, Side panel, Rear panel**

As this system is of the rear projection type, it must be enclosed to avoid exposure to external light. (Fig.3-38)

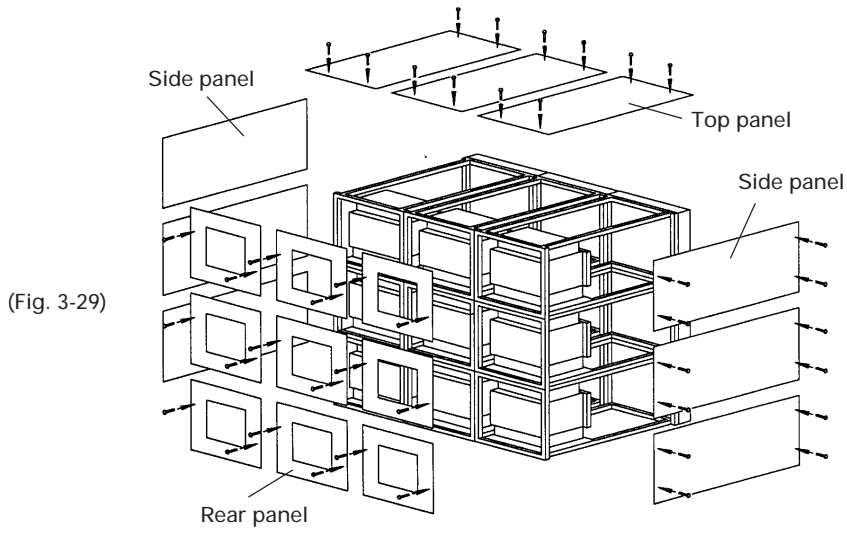

(Fig. 3-38)

■ Installing the Enclosure

- The panels can be attached easily by using the linking holes of the unit. (See Fig. 3-39)

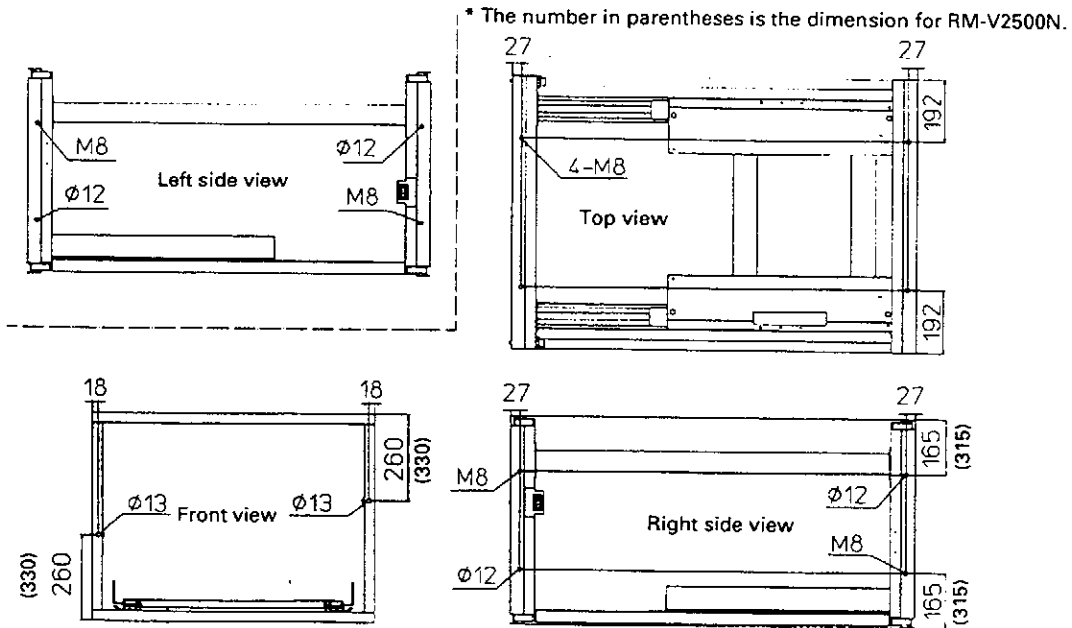

(Fig. 3-39)

- As shown in Fig. 3-40, attach the top panels and side panels starting from the top panels at the center outwards. Attach the side panels from the top downwards. The rear panels can be attached in any order.

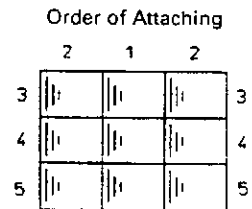

(Fig. 3-40)

③' Attaching the Multi Projection Unit (RM-V2400N) to the Projection Cabinet (RMF-V4011R)

The figure shows the assembling procedure of the left attachment. Assemble the right attachment in the same way. The parts on the right side of the screen are R and those on the left side are L from the view point against the screen.

- (1) Attach the attachments R and L (BNG1173, 1174) to the front of frames R and L (BNG1207, 1208) using the screw (M5 × 15).

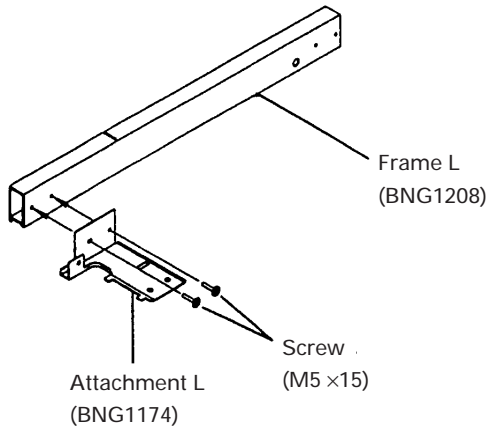

- (2) Insert the claws of holders R and L (BNG1150, 1151) into the slits of frames R and L, rotate them as shown in the figure, and attach using the screws (M5 × 15). (2 pieces × 2 locations).

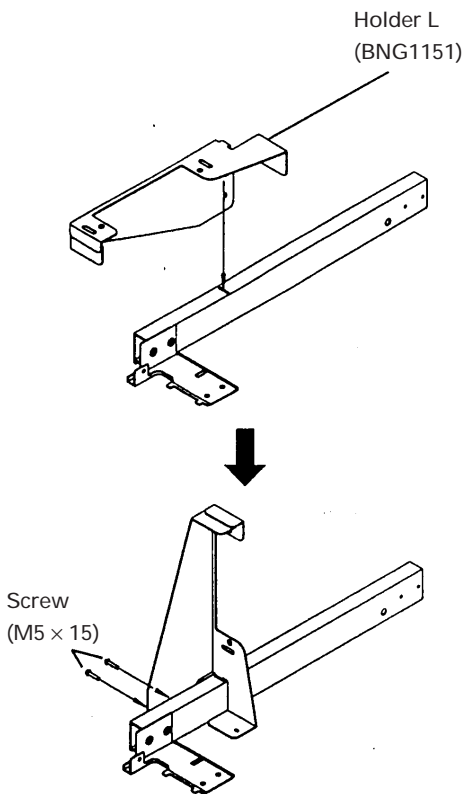

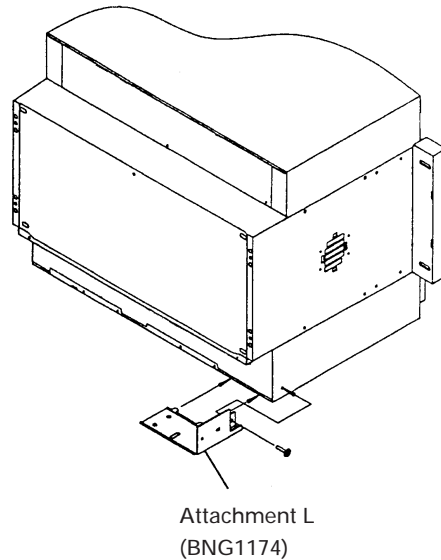

- (3) Insert the claws of the attachments R and L into the rear slits of the multi-projection unit, and attach using the screws (M5 × 15). (1 piece × 2 locations).

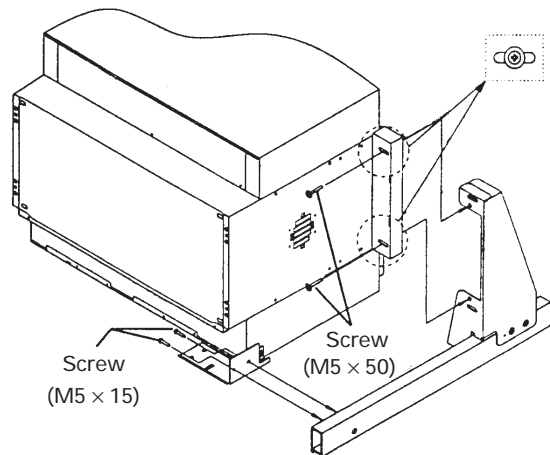

*Drop the screw-lock fluid to screws so as not to loosen.(Right and left)

- (4) Attach the parts assembled at steps (1) and (2) onto the multi-projection unit. Attach the attachments R and L to frames R and L. Using the screw (M5 × 15) as shown in the figure, and attach the attachments R and L to the rear of the projection unit using the screws (M5 × 50). (2 screws × 2 locations).



- (5) Paste cushion A (BMR1106) to the top board of the multi-projection unit and cushion B (BMR1107) to the two sides at the  position shown in the figure after peeling off the seal.

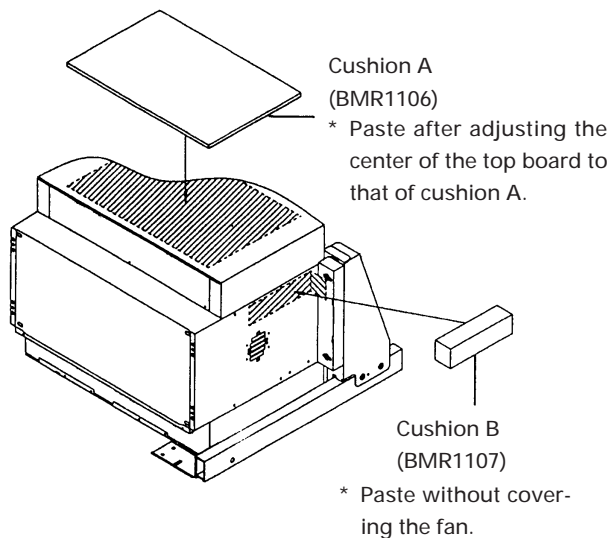

- (7) Attach the attachments R and L to the unit through the top board of the unit using the screws (M6 × 20) and then attach attachments R and L to the unit from the back using screws (M6 × 20). (2 screws × 2 locations).

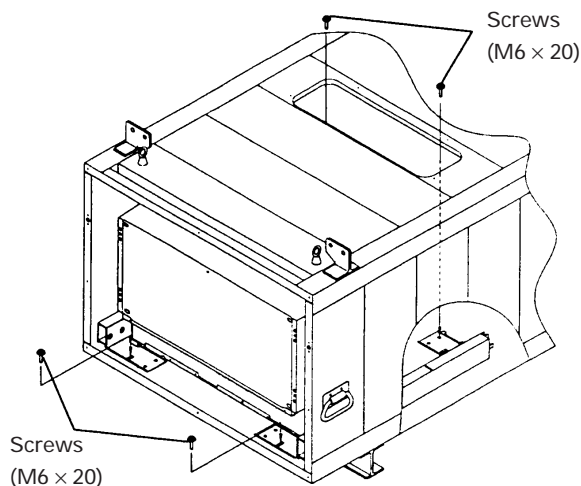

- * Drop the screw-lock fluid to screws so as not to loosen. (4 points)

- (8) Check the Focus and readjust if necessary.

- (6) Insert the multi-projection unit from the rear of the unit in this state.

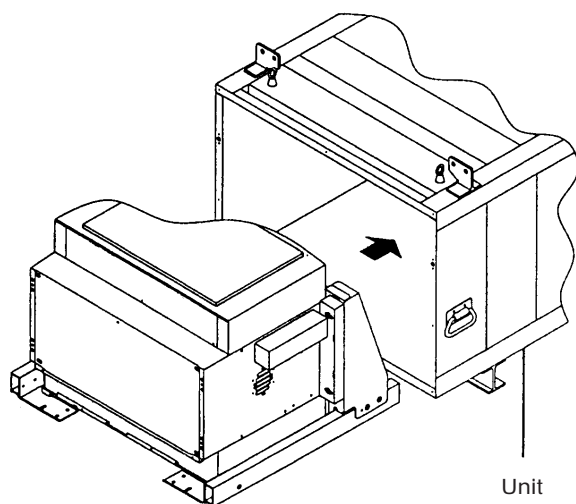

- (9) Attach the cover (BNE1012) to the top board of the unit using the four screws (M5 × 15).

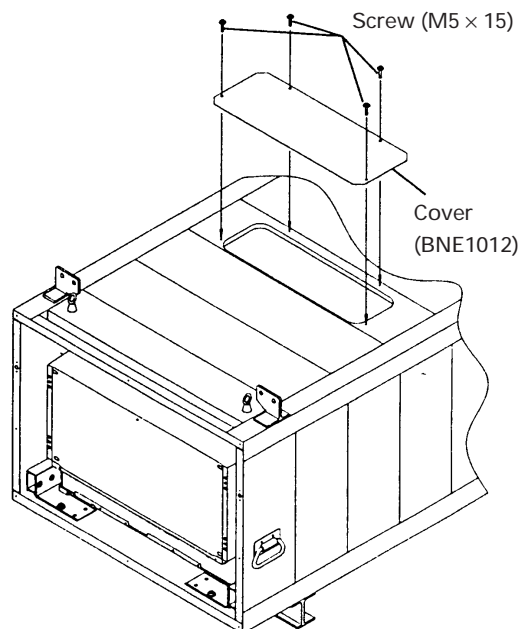

INSTALLATION AND ASSEMBLY

(10) Attach the adjuster (BEF1011) attached with a nut (M8) to the rear holders R and L (BNG1205, 1206).

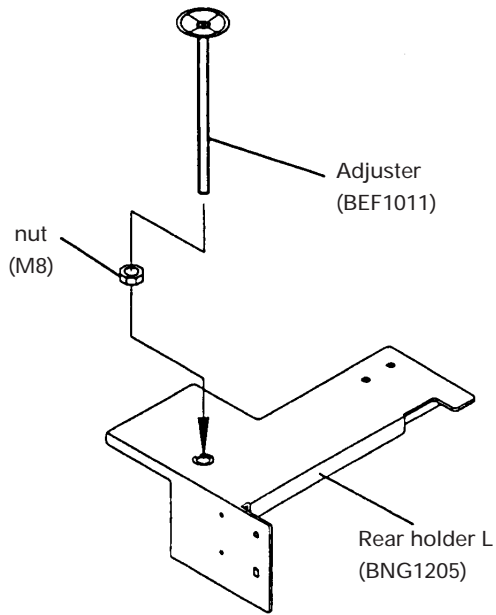

(11) While tilting the parts assembled at step 10, insert it into the holes on the shoulder of the multi-projection unit and attach with the screws (3 × 12). (2 screws × 2 locations). Furthermore, pull up the adjuster to the top of the unit while rotating it, and pull down the nut to the rear holders R and L while rotating it to secure the projection unit.

* Tighten the nuts tightly.

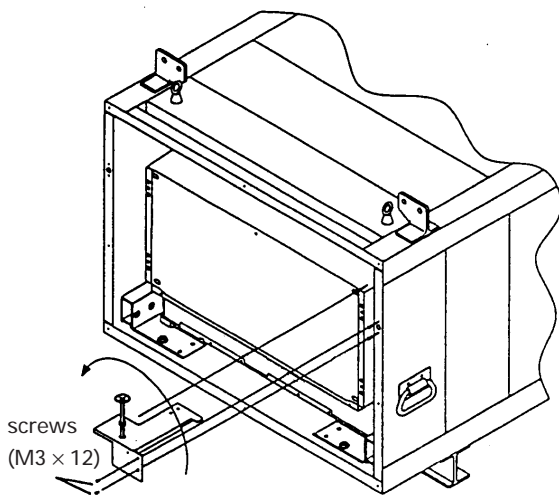

(12) Attach each rear panel (BMR1069, 1070, 1071, 1072) to the unit and the rear holders R and L using the screws (3 × 8). Furthermore, to cover up the gap at the top of the projection unit, paste the hinder panel (BMR1075) over the top board and projection unit.

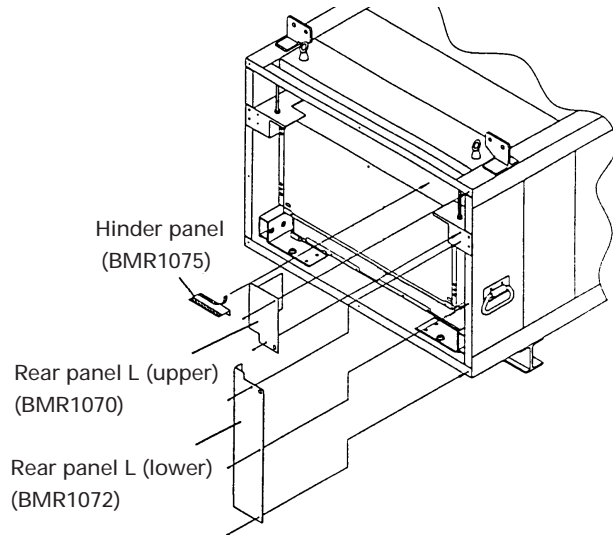

Screw : M3 × 8

[After Completion]

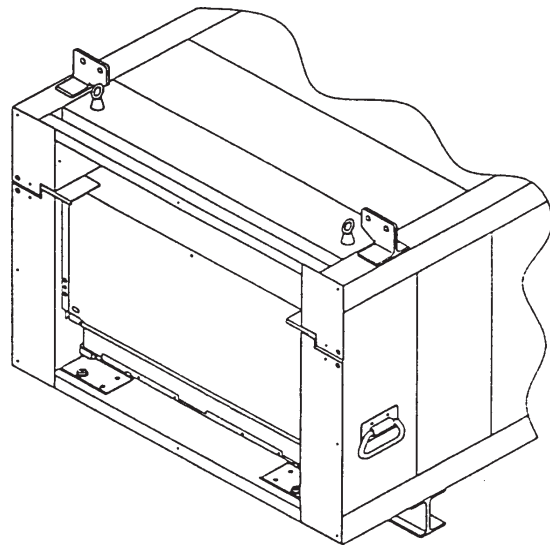

④ Mounting the Projection Cabinet (RMF-V4011R)

Projection cabinet can mount to use the conventional method. For details, refer to the RM-V2000A technical manual.

⑦' **Mount the multi-projection unit (RM-V2400N) to the Projection Cabinet (RMF-V4011CR)**

The figure shows how the left side attachment is assembled. Assemble the right attachment in the same way.

To differentiate the R and L of the parts, those on the right side of the screen as seen from the front are R and those on the left are L.

- (1) Attach the engine guide to the projection unit with screws.

Attach the engine guide so that the distance between the top edge of the engine guide and the top edge of the unit and the distance between the bottom edge of the engine guide and the bottom edge of the unit are equal.

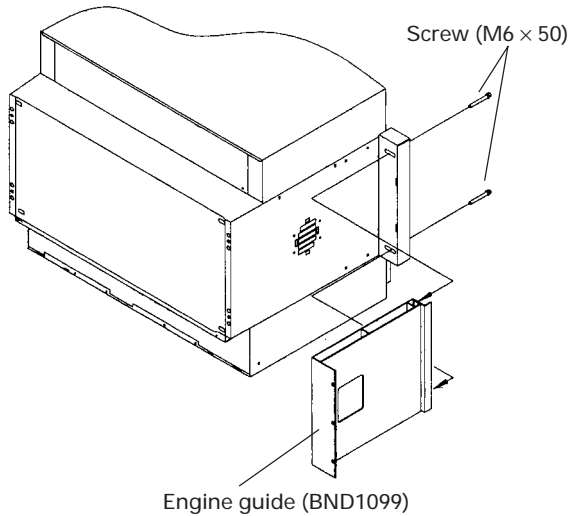

- (3) Insert the projection unit from the rear of the cabinet.

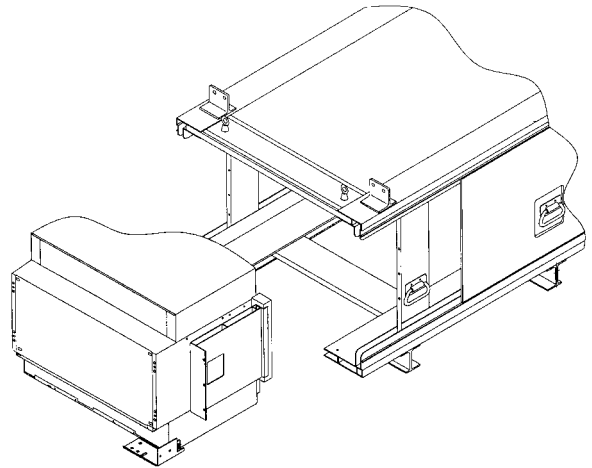

- (4) Attach fixtures R and L and the engine guide to the projection unit with screws.

* Secure the M6 x 20 with a screw-locking compound.

- (2) Insert the claws of fixtures R (BNG1173) and L (BNG1174) into the slits at the back of the projection unit.

* Secure the screws with a screw-locking compound.

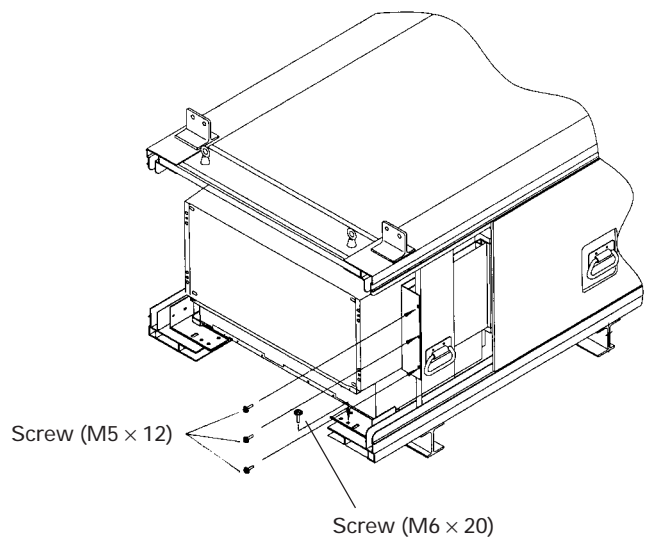
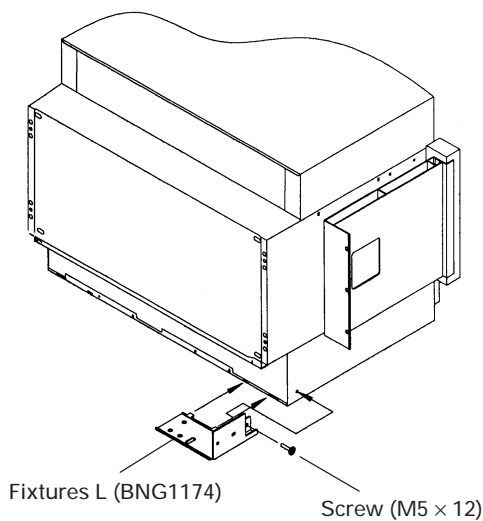

INSTALLATION AND ASSEMBLY

(5) After the above setup, decide the position of the douser panel so that no light leaks inside the unit.

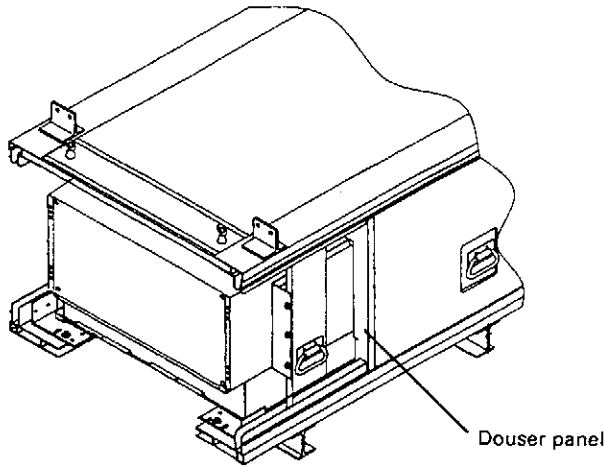

⑧ Assembling the projection cabinet (RMF-V4011R/V4011CR)

Note

The parts of the cabinet to which the screen is attached have weak structures. Especially do not press or lift up the left side and bottom (as seen from the front of the screen) strongly as the screen may fall off. (Carry as shown in Fig. 3-41.)

- Assemble the RM-V4011R in the same way as before. For details, refer to the technical manual for the RM-V2000A.
- For the RMF-V4011CR, the tilt (top, bottom, left and right) of the screen can be finely adjusted by inserting or removing cabinet spacers. Insert or remove spacers as desired. For details, refer to [Chapter 5. 1. Maintenance].

Note 1:

Not more than one person can climb onto the top of the cabinet in installation work, etc. to prevent unnecessary load from being applied.

Note 2:

When mounting RMF-V4011R and RMF-V4011CR together, rotate the hanging fixture by 90° as described below (See Fig. 3-42) beforehand so that the hanging fixture hole can be seen from the screen.

- ① Remove the top cover of the cabinet.
- ② Insert your hand into the hole at the top and rotate the screw (M10) securing the hanging fixture.
- ③ The hanging fixture will rotate together with the screw. Rotate the screw so that the fixture comes to the 90° position.

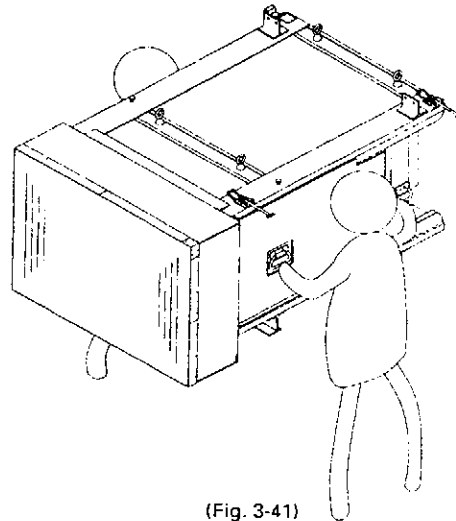

(Fig. 3-41)

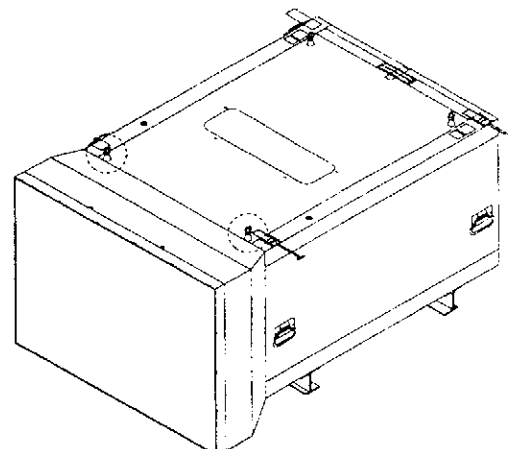

(Fig. 3-42)

⑨ Removal of RM-V2400N

Perform the following steps to remove RM-V2400N from RMF-V4011CR.

[1] When removing from the rear

- 1) Remove the screws of the engine guide and fixtures R and L attached to the cabinet.

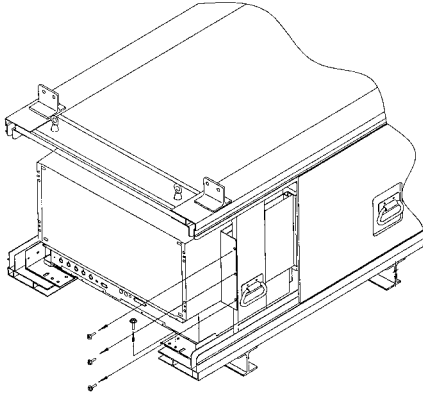

- 2) Pull out the projection unit.
Leave the engine guide and fixtures R and L attached to the projection unit.

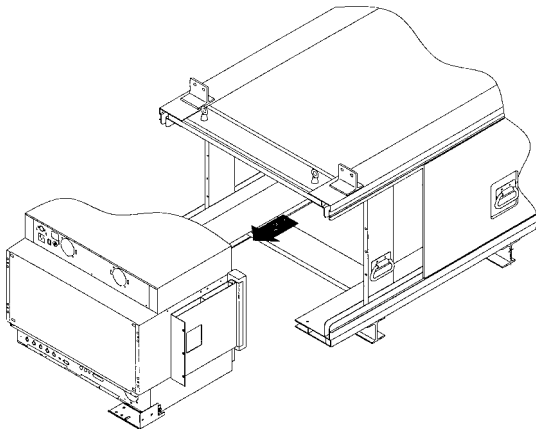

(Note) The projection unit should be removed by more than two persons always.

- [2] When removing from the screen side
- Excluding exceptional cases, remove the projection unit from the rear.

- 1) Before assembling the cabinet, remove the screws at the side securing the fixtures R and L to the projection unit.
Keep these screws carefully because they are to be attached again when transporting the cabinet.

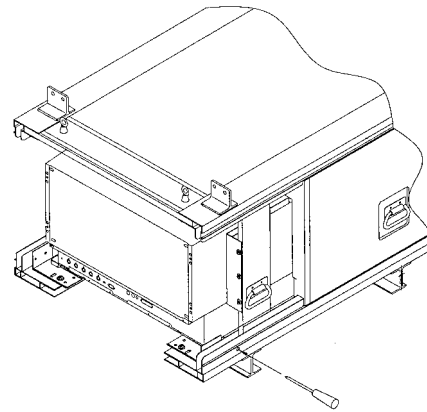

- 2) Remove the screen (Refer to Replacing the Screen in "Chapter 5.1. Maintenance".)
- 3) Remove the screws attaching the projection unit and engine guide.

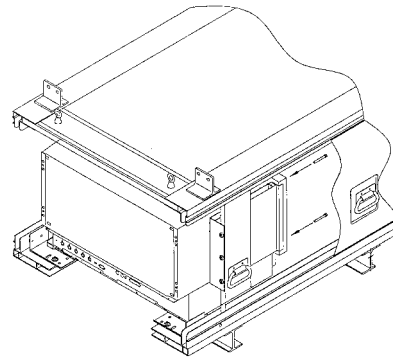

- 4) Push out the projection unit. Leave the engine guide and fixtures R and L attached to the cabinet.

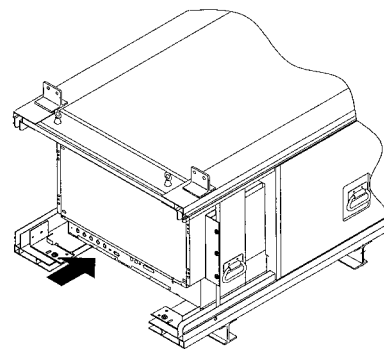

(Note)

If the screws at the side securing the fixtures R and L to the projection unit have not been removed at step 1) :

- a) Remove the screws securing the fixtures R and L to the cabinet.
- b) Lift up the rear of the projection unit, and pull it out from the screen side. In this case, the fixtures R and L are attached to the projection unit.

5. SPECIAL INSTALLATION

(1) Wall inset

- If removing the screen after installing the system, the person must go behind the screen (diagonally shaded part of the figure). Therefore when inseting the unit in the wall, careful take this into account before installation.

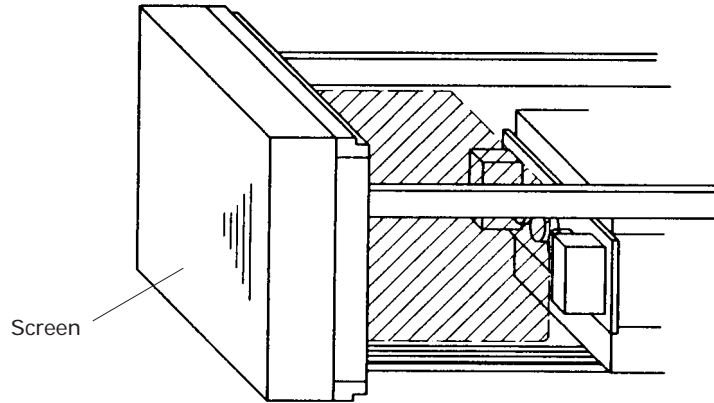

(Fig. 3-43)

- When fixing the screen into the wall, space for placing your hand inside the wall at the top, bottom, right, and left will be required in addition to the above in order to attach and remove the screen.

(2) Diagonal installation

- This system cannot be placed facing upwards or downwards and diagonally. Always place it horizontally. However, Multiprojection unit (RM-V4000NA/V5000NA) alone can be tilted at the up to 45 deg. Installation of special order screens and cabinets should also become possible in the near future.

(3) Architrave processing

- When enclosing the screen with a frame, etc., add 15 mm to the dimensions of the assembled screen at the top, bottom, left, and right.
* Perform framing constructions after assembling the screen.

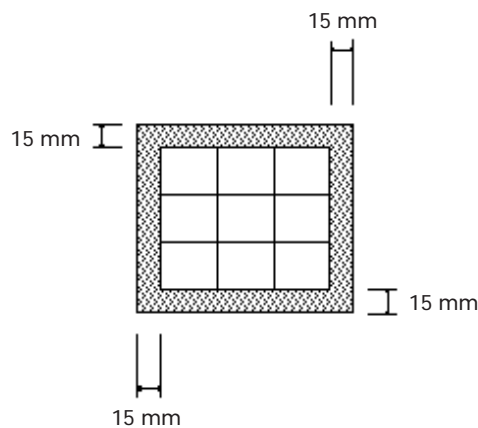

(Fig. 3-44)

- If light leaks from the rear space after constructions, place a blind plate over the rear.
- No one should climb onto the top board. (RMF-V4011/V5011)

(4) Upside down installation

- Not possible

(5) Hanging from ceiling

- Not possible

CHAPTER 4. ADJUSTMENTS

1. ADJUSTMENT PREPARATIONS

(1) Wiring

① Connection of Power Supply

- The power supply can be connected to up to 3 units in a series using the AC outlets of Multi projection units. Connect the three units as one system to the external outlet.
- The AC plug of Multi projection unit is a 3P with a ground pin. When connecting it to a normal outlet, use an exclusive 3P AC adapter.
- The AC plug of Multi projection unit is a 3P with a ground pin. To prevent electric shocks, connect the ground pin to the ground when connecting the power supply.

② Connection of signal cable

- Use coaxial cables. Normally, if less than 15m, use 3C-2V. If less than 30m, use 5C-2V.
The signal transmission equipment and Multi projection units should be as close as possible to each other.

③ Connection of ABL link cable

- By connecting the ABL link cables in cascade form, control signals (RS-232C, remote control signal) can be transmitted to all the units.

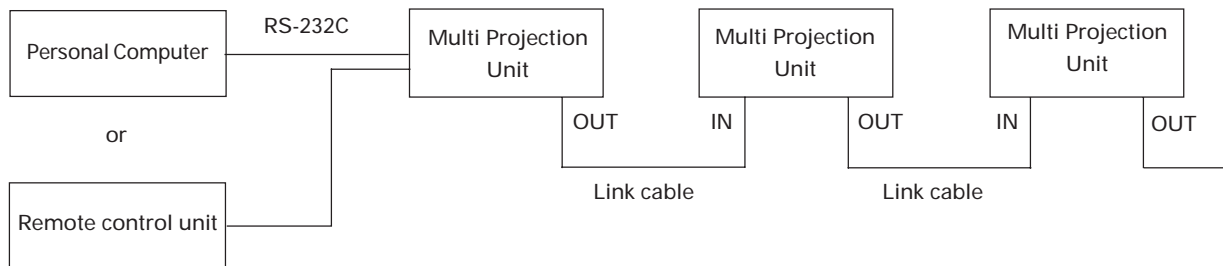

(Up to 16 units can be operated using the remote control unit at one time using the link cable.)

(2) Wiring Handling

- Except for short-term installations such as events, etc., in normal long-term installations, adjust the length of the wiring appropriately taking into consideration the overall route to be wired.
- Make sure the connection terminals are not subjected to direct weight and force. Tie the wires up in short-term use and bind them up properly in long-term use.

(3) Aging

- After turning on the power, input the 100% white signal or moving images, and perform aging until Multi projection unit stabilizes (about 1 hour). If adjustments are performed without aging, as it takes time until Multi projection unit will warm up and stabilize, convergence and white balance will become incorrect.

(4) Adjustment Signals

- Use the composite video signal for adjustments created in the multi video processor. When converters not creating the signals for adjustment are used, supply the signals for adjustment from equivalent signal sources (signal generator, LD player, etc.)

○Generally Required Signals

Adjustment	Signal Name
• Screen center Screen size adjustment	Monoscope
• Convergence adjustment	Crosshatch Tilted crosshatch
• White balance adjustment	White signal (Can be linearly varied between 0% and 100%) Or window step
• Linear white adjustment	Crosshatch
• Total adjustment (Color, tint, etc.)	Moving image (scenery, faces) Color-bar, etc.

(5) Equipment Required for Adjustments

The following are required for the adjustments performed during the set-up of Multi projection unit.

Equipment	Role	Required Function	Recommended Model	Remarks
Personal Computer	For adjusting	RS232C communication function		
Adjusting remote control	For adjusting		Pioneer RU-V107	Prepare a Personal Computer or this remote control for adjustment.
Signal generator	For generating white balance and color tint adjusting signals	Gray scale White (% variable)		Especially white (% variable) is important. (Cannot replace with LD, etc.) Use signal generators of this class at the least.
Adjusting LD	Total image quality adjustment	High definition image Picture of beauty Various adjustment signals	LD demonstration 2 (Not for sale)	Perform color, or final and overall adjustments with the actual images.
LD player	For playing adjusting LD	With still function	Pioneer LD-V4400	
Cable	For connecting RS-232C	D-Sub 25-pin (male) straight cable		The length differs according to the place adjustment is performed at, but prepare at least 10 m.
	For connecting video			
Adjusting LD	For generating signals for adjusting size, convergence	Monoscope Crosshatch	Test disc GGT 1072	Use for adjusting screen size and center.

2. BEFORE ADJUSTMENTS

(1) Convergence Adjustment Memory

The multi projection unit incorporates four convergence adjustment memories. These can broadly be divided into the adjustable memory (Memories 1 to 3) and dedicated memory for reading adjustment values set at shipment (FACTORY).

Input Signal \ Memory Area	Memory Area			FACTORY
	1	2	3	
NTSC	○	○	○	⊙
PAL	○	○	○	⊙

- : Enable to select.
- ⊙ : Disable to select. Only possible to read out to the memory area enable to select.

The following adjustment data are input to each memory area at shipment.

- MEMO-1 : For NTSC signals
- MEMO-2 : For PAL signals
- MEMO-3 : For NTSC signals (Same data as MEMO-1) ----- for RM-V2400NA / V2500NA
: For PAL signals (Same data as MEMO-2) ----- for RM-V2400NE / V2500NE
- FACTORY : For NTSC signals (Same data as MEMO-1) ----- for RM-V2400NA / V2500NA
: For PAL signals (Same data as MEMO-2) ----- for RM-V2400NE / V2500NE

For some input signals, NTSC and PAL are selected automatically.

- When a NTSC signal is input : MEMO-1
- When a PAL signal is input : MEMO-2

Copying the Convergence Memory

The convergence memory can be copied by the remote control unit or PC. (See figure below.)

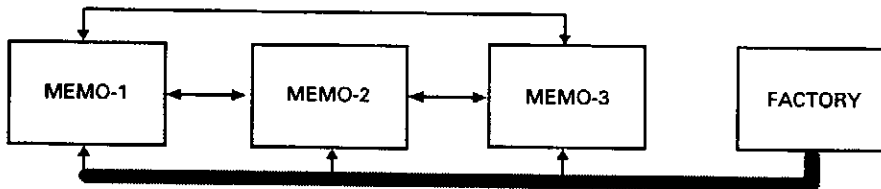

When data is copied, the memory into which the data is copied will lose its original data. (For example, when data is copied from MEMO-1 to MEMO-2, MEMO-2 will become the memory for the NTSC signal, and lose the PAL signal.)

When the data has been copied into the selected convergence memory area, this can be known by the display [COPY END] on the screen. In that case, the data of the convergence has been changed into new data. If the data is not same, the convergence will change as well.

Example : When MEMO-1 is selected

- MEMO-1 → Copy to other memories: Completed when [COPY END] is displayed on the screen.
- MEMO-1 ← Copy to other memories: Completed when [COPY END] is displayed on the screen and at the same time convergence deviates.

Condition : MEMO-1 data ≠ MEMO-2 data

(2) TV System

The TV system determines the control of the whole unit (convergence, OSD display select, video system select, deflection) according to the signal input.

Set it according to the signal input.

When TV SYSTEM is set to AUTO

- The mode is automatically set to NTSC or PAL according to the input signal (NTSC/PAL).

When the TV SYSTEM is set to NTSC

- The mode is set to NTSC regardless of the input signal.

When the TV SYSTEM is set to PAL

- The mode is set to PAL regardless of the input signal.

[Precaution to use]

Normally, the TV SYSTEM is set to AUTO. If the signals cannot be differentiated between NTSC and PAL (or they are differentiated incorrectly : VCR signal repeatedly dubbed or part of CATV converter, etc.), the TV SYSTEM is set to NTSC or PAL according to the input signal.

When the input signal is NTSC or PAL, and the TV SYSTEM is set to NTSC or PAL, it can enable the input to be switched smoothly (little screen noises), and prevent signals from being differentiated incorrectly due to signal disturbances and cuts.

In some cases, even if the same TV format is used, more than two types of convergence data will be required. (For example, when there are signal phase differences for every input source, etc.) In such cases, use two types of memories. Switch them using the personal computer.

ADJUSTMENTS

(3) White Balance Adjustment Memory

ADJUSTMENTS has altogether six white balance adjustment memories.

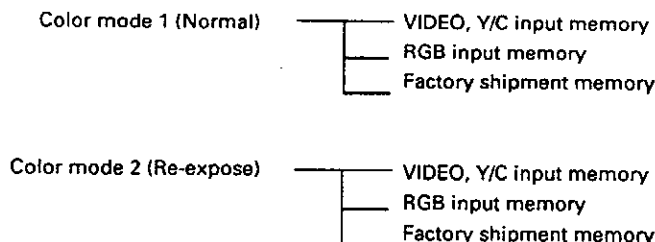

Four memories can be actually adjusted except the factory shipment memory. The factory shipment memory contains the normal white balance adjustment data and re-expose white balance adjustment data.

By setting to color mode 1 using the rear panel switch, etc., the white balance adjustment data can be switched by synchronizing with input switching. This is the same for color mode 2. If it is necessary to change color mode 1 and 2 in the same input function or VIDEO, Y/C input, connect the PC and switch each time by command(CM1,CM2).

(4) Combined Use of Remote Control and Personal Computer

Although it is possible to connect both the remote control (RU-V107) and Personal Computer, adjustments cannot be performed using both at the same time.

Remote control, Personal Computer commands and rear panel switches operated the latest are given priority. When the adjustment mode is set by the Personal Computer while adjusting with the remote control, the adjustment mode will be set by the Personal Computer, disabling adjustments to be performed using the remote control. If the adjustment mode is set by the remote control using adjustments by the Personal Computer, adjustments by the Personal Computer will be disabled. Furthermore, if the rear panel switches are operated when the adjustment mode is set by the remote control or Personal Computer, the adjustment mode is exited and the rear panel switches operations are started.

(5) Memory of Adjustment Data and Settings

When adjustments are ended in the adjustment mode such as convergence, white balance, etc., always exit the adjustment mode (AJN for Personal Computer, ADJ OUT key for remote control). If the power is turned off (AC OFF) without exiting the adjustment mode, a part of the adjustment data will not be preserved in the memory.

The input function, MULTI ON/OFF (peripheral light amount switching), COLOR MODE 1/2 (white balance switching), COMBINATION ON/OFF (ABL link switching), VIDEO MUTE ON/OFF (VIDEO MUTE of input switching), baud rate setting, TV SYSTEM setting, and convergence memory state setting will be preserved in the memory only when the power is turned off using the remote control, command of a Personal Computer (POF) or the rear panel tact switch, and finish the adjustment mode (when you set each data in the adjustment mode.) (The Main Power SW ON/OFF or AC ON/OFF by the external SW will not allow data to be preserved in the memory.)

When starting or stopping the system by AC ON/OFF in an installation condition for demonstration, use this method to preserve the conditions in the memory first and confirm the initial condition by AC ON/OFF.

The following phenomena may occur when discharge occurs.

Example : During performance in which inputs are switched using the personal computer (VIDEO ⇄ RGB)

When discharge occurs, RGB is switched to VIDEO.

This phenomenon occurs because at the same time discharge occurs, the INPUT set is initialized in the previous memorized state (in this example, it is the VIDEO input). Therefore pay careful attention when using the memory.

(6) Giving IDs

When several Multi projection units are used to compose the 9 screens or 16 screens (multi-screen), the ID is used to differentiate between Multi projection units. When the units are given IDs, by connecting the ABL link cable, commands can be transmitted by specifying the ID, and it is possible to operate only Multi projection unit corresponding to that ID by remote control operations.

<Giving IDs using Personal Computer>

Commands: IDC (IDC CLEAR) ;Clears the ID given

IDS (ID SET) ;Gives an ID

The IDS is valid only when no ID has been given. It will be valid from units nearest to the personal computer (remote control).

(Example) 4 screens • When giving IDs first using Personal Computer.

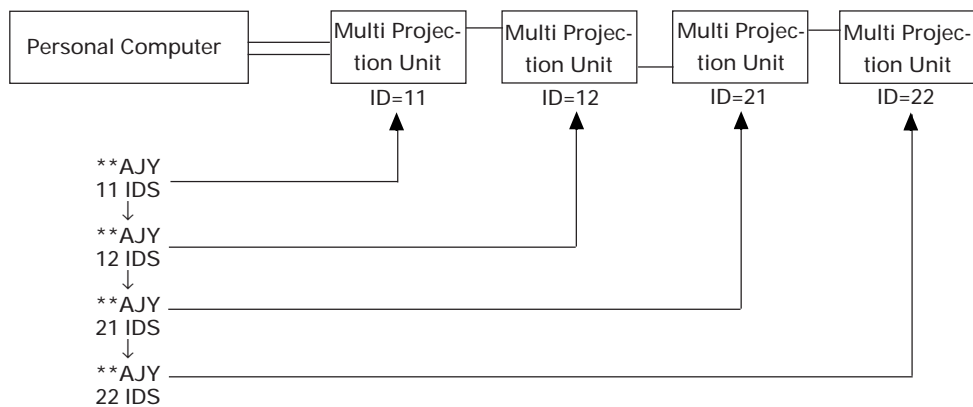

By sending commands in this order, IDs can be given to each Multi Projection Unit (connect ABL link cables as above example).

The characters that can be used for the IDs are 0 to 9 and A to F, and * (capital and small letters are not differentiated).

The * can be used in the following way.









** IDC :Clears IDs given to all units

*1AJY :Only units which have IDs whose 2nd digit is 1 enter the adjustment mode.

2* IN1 :The input function of only units which have IDs whose 1st digit is 2 is set to VIDEO.

ADJUSTMENTS

<Giving IDs Using the Remote Control>

- [1] Press the  key to set the whole screen into the adjustment mode.
- [2] The main menu will be displayed. Press the  key.
Select "1. ID SET/CLEAR/SELECT"
- [3] Check that the ID display at the top left of the screen is "--" and press the  key.
Select "1.ID SET".
If an ID has already been given, press the  key, select "0. ID CLEAR" of the main menu, return to "[1] Enter the adjustment mode." and give the ID.
- [4] As the ID input standby state is set, press the  to ,  to  keys, and input the ID.
- [5] To use the multi-screen unit, return to "[1] Enter the adjustment mode." and given an ID to the next unit.









Note) To return the whole screen to the main menu after giving IDs to the whole screen, press the  key.

<Selecting the ID Using the Remote Control>

Select the screen to be adjusted using the remote control.

Example) Select the ID at the bottom left side of the screen (ID=21) as shown in the figure on the right.

ID = 11	ID = 12
ID = 21	ID = 22

- [1] Set all screens to the adjustment mode using the  key.
- [2] Select [1. ID SET/CLEAR/SELECT using the  key.
- [3] Select [2. ID SELECT] using the  key.
- [4] Press the  and  keys (ID=21).
- [5] Only the bottom left side of the screen shows the main menu. The other screens will set into the standby state
(, ,  keys only are accepted).

- To return to the main menu after completing ID SELECT, press the  key to keep the ID SELECT state.

Pressing the  key will also return to the main menu, but it also clear the ID SELECT state, making it necessary to repeat from step [1] again.

To select other screens, press the  key to return to the main menu, and change the ID number set at step [4] above.

Note : When the wrong ID has been specified

Repeat the above steps [1] to [5].

Perform the same steps when an inappropriate ID (Example : ID=33, etc. in the above screen) has been input. In this case, all screens will set into the standby state.

<Precautions for Giving IDs using the Remote Control and Personal Computer>

Communication cannot be performed with units connected using the ABL link cable, after units whose IDs have been cleared. When the command "*** IDC" shown in the figure on the previous page is performed, only the first unit can be controlled. Using the command "11 IDS" will enable the 2nd unit and onwards to be controlled. When IDs are set as this, the unit connected next can be controlled.

3. EXAMPLES OF MAIN USES OF MULTI-PROJECTION UNITS

(1) Expansion/Individual Switching at Multi Video Processor Side - General example

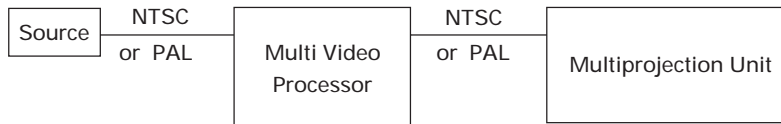

TV SYSTEM) AUTO
 Converter data required at display) One

(2) When Switching Source Inputs to Multi Video Processor

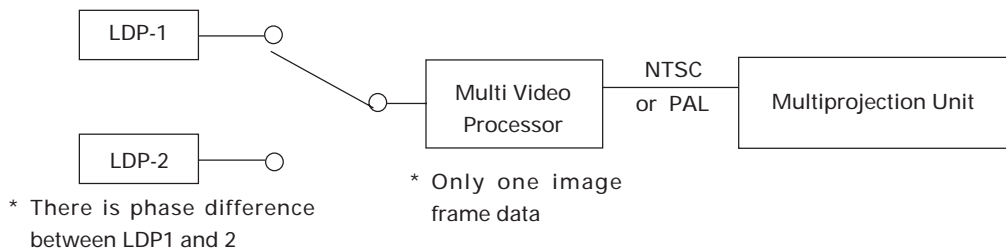

TV SYSTEM) AUTO
 Converter data required for display) Two
 * For example, adjust LDP-1 with MEMORY 1 and LDP-2 with MEMORY 3 and switch data by external control when switching LDP .

4. SCREEN ADJUSTMENTS

(1) Adjustment Flowchart

The following shows the order for performing the adjustments generally required in the setup of the multi-projection system. For details, see the descriptions on the next page and later.

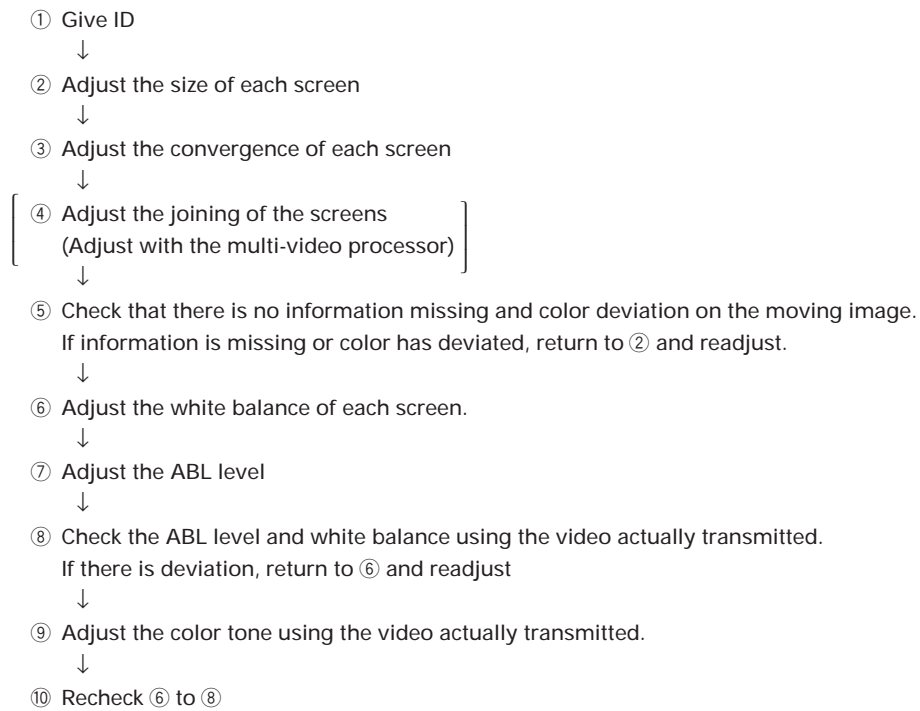

(2) Convergence Adjustment Flowchart

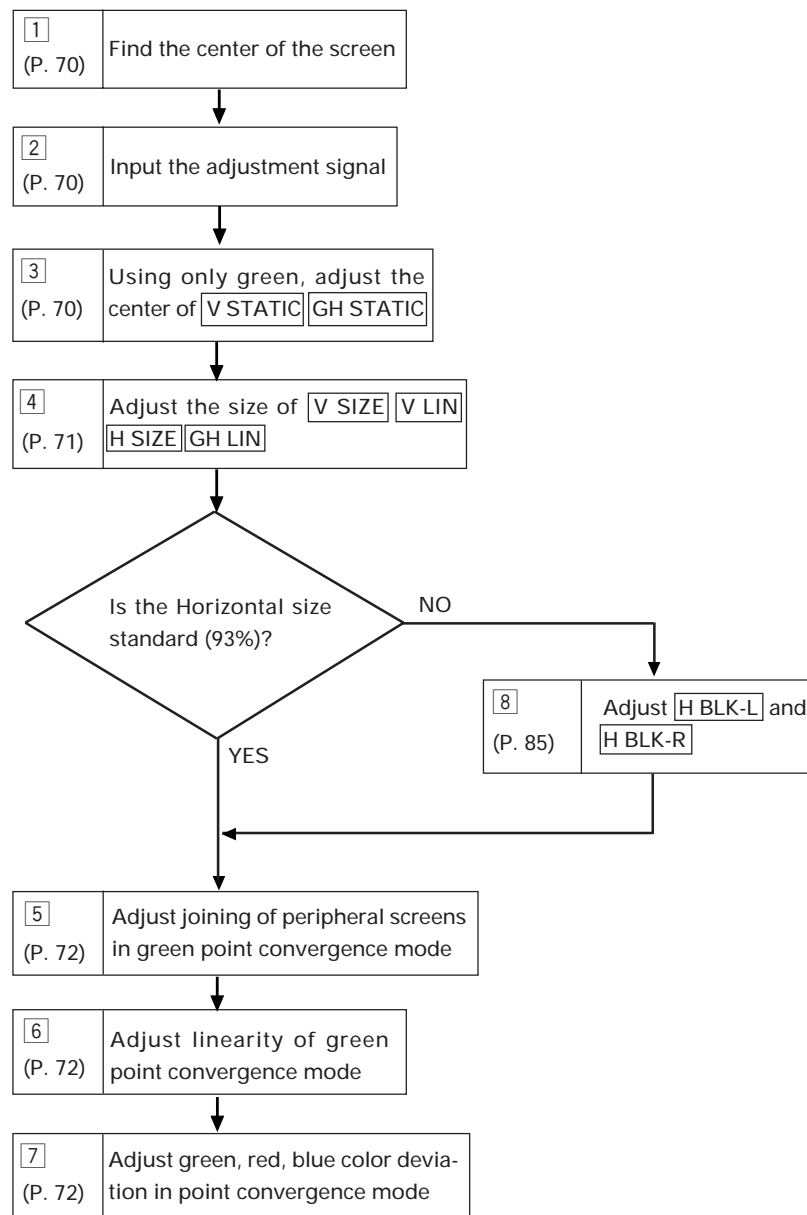

(3) Convergence Adjustment Contents

The □ numbers correspond to the numbers in the flow-chart.

1 Measurement of screen center

The center can be found easily by pasting threads in the spaces of the protection panels at the screen frame.

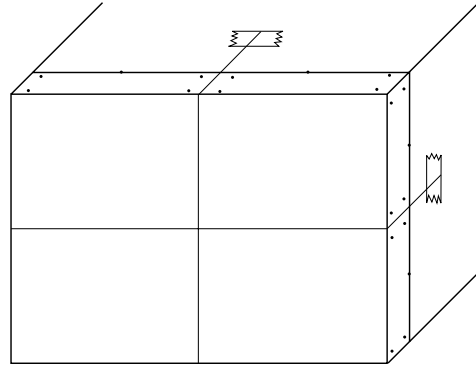

2 Adjustment signal input

For adjusting size...Frame size picture(EX.LD Test disc GGT1072, FRAME No. 5941),Monoscope, etc.

For screen joining, linearity, color adjustment...Use adjustment signals such as , cross-hatch, etc.

(EX. LD Test disc GGT1072, FRAME No. 7081,etc.)

If signals are created in the multi video processor, use them.

Input the above adjustment signals via the Multi Video Processor actually used.

Note : For the particulars about the FRAME No.,etc. of LD Test disc GGT1072,refer to the disc manual differently.

3 Center adjustment

Set to only green and adjust the center with V STATIC
GH STATIC.

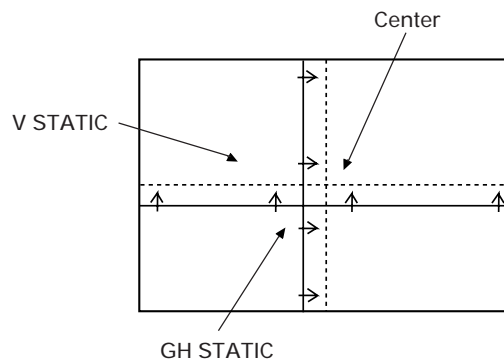

4] V SIZE, V LIN, H SIZE Adjustment**① V SIZE adjustment**

Set to only green, observe the **top part of the screen**, and adjust the data amount in the vertical direction using **V SIZE**.

Do not observe the bottom part of the screen.

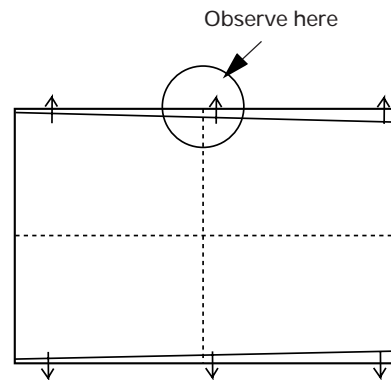
**② H SIZE adjustment**

Set to only green, observe the **right side of the screen**, and adjust the data amount in the horizontal direction using **H SIZE**.

Do not observe the left side of the screen.

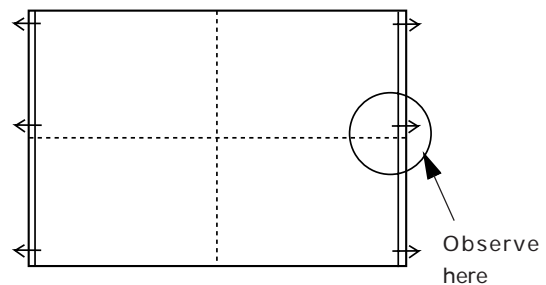
**③ V SIZE, V LINEARITY, H SIZE, GH LINEARITY adjustment**

Those familiar with the convergence adjustment can adjust the **bottom part of the screen** in addition to the **top part of the screen** using **V SIZE** and **V LINEARITY**. Also it can adjust the **left side of the screen** in addition to the **right side of the screen** using **H SIZE** and **GH LINEARITY**.

Reference Information

To adjust the NTSC input for horizontal 93% and vertical 92%, use the frame size screen of the LD test disc GGT1072 (frame No. 5941).

Horizontal : Adjust so that the sixth 92.5% line from the inside can be seen completely.

Vertical : Adjust so that the sixth 92.5% line from the inside can be seen only slightly.

ADJUSTMENTS

5, 6, 7, Point convergence adjustment

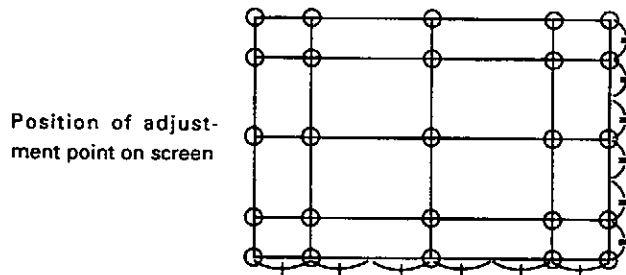

- In point convergence adjustment, the 25 points set on the screen can be adjusted individually.
In addition, the area (total ten areas of five lines and ranks) of the four sides of the screen can be adjusted.

NOTES

- The adjusting points set by the circuit are fixed at the positions shown in the figure. In some cases, the OSD display may deviate. But the actual adjusting points are as shown in the figure.
- Deviation between two adjusting points will naturally be corrected when the deviation of each point is corrected.

Movement of screen by point convergence adjustment

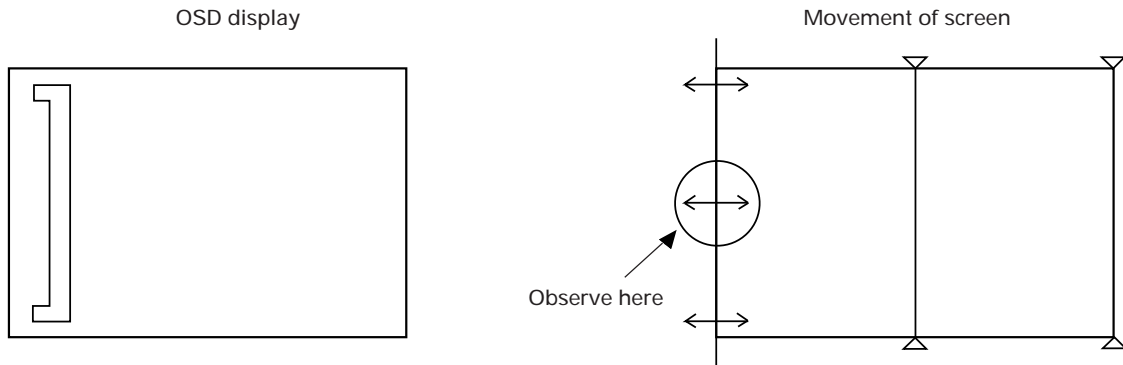

Use especially when adjusting the horizontal size of the left side of the screen.

In addition, there are nine other area adjustments. It is a convenience to adjust deviation of circumference screens.

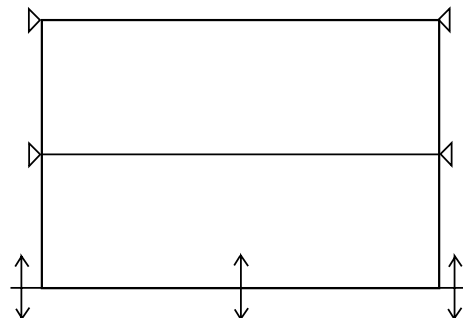
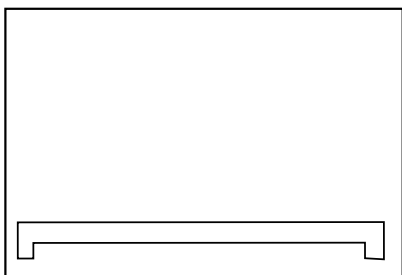
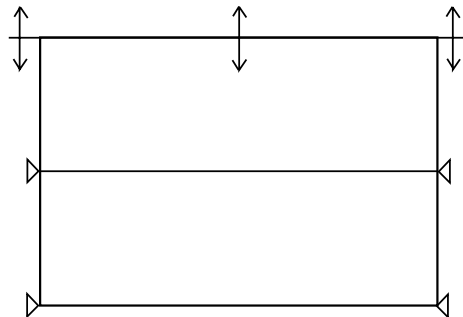
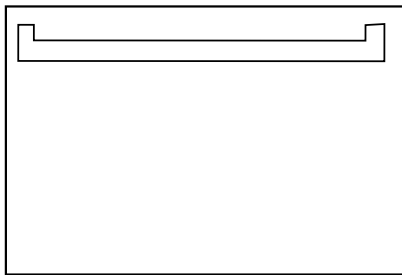
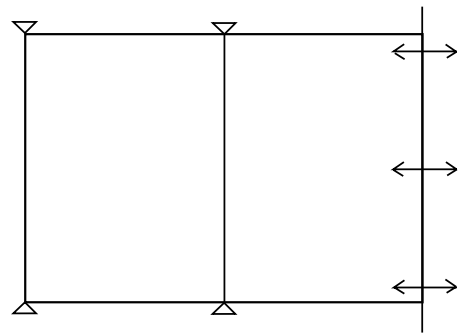

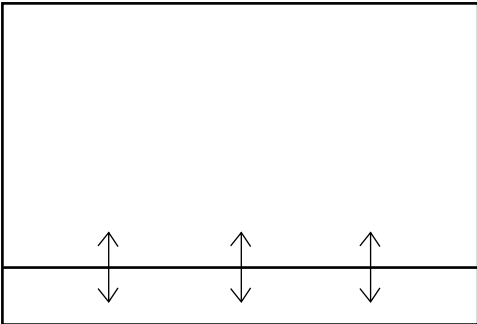
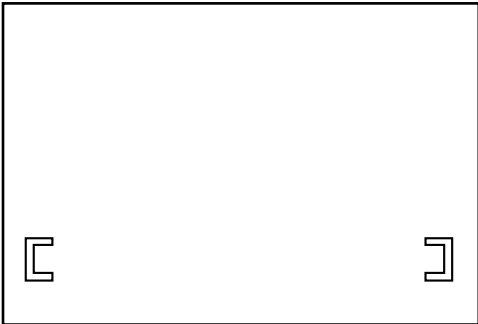
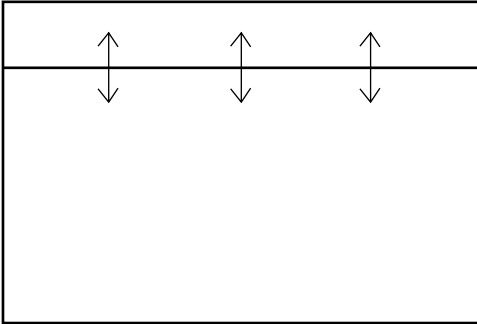
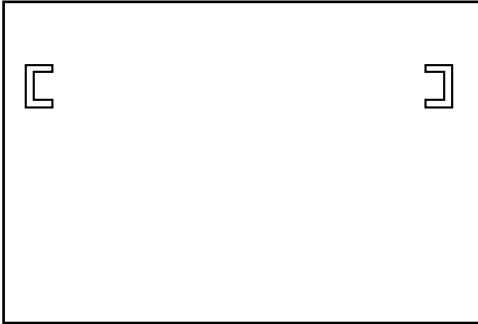
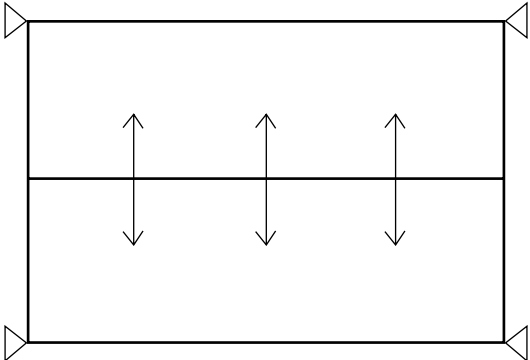
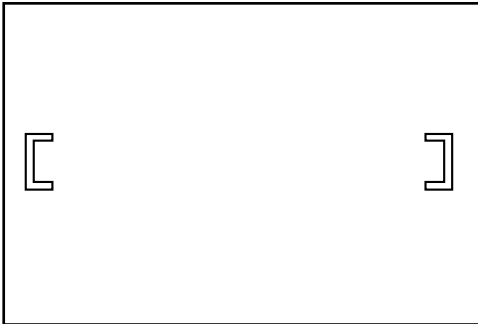
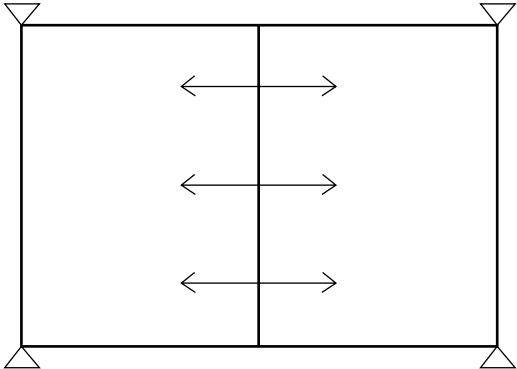
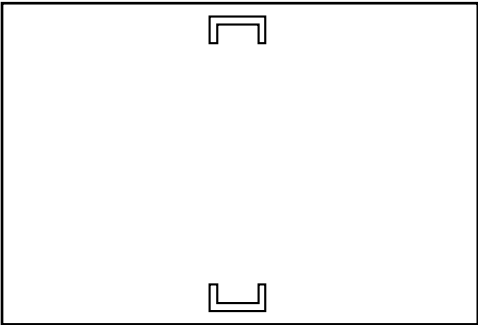

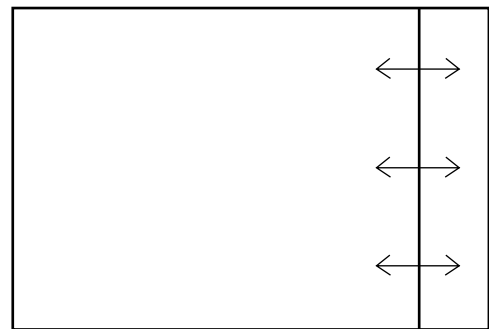
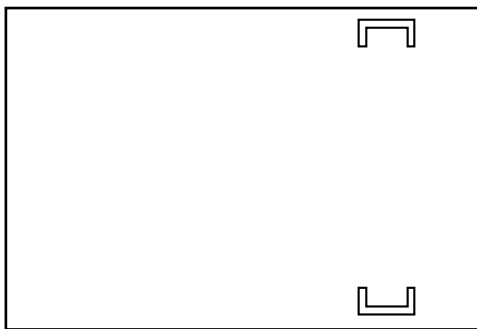
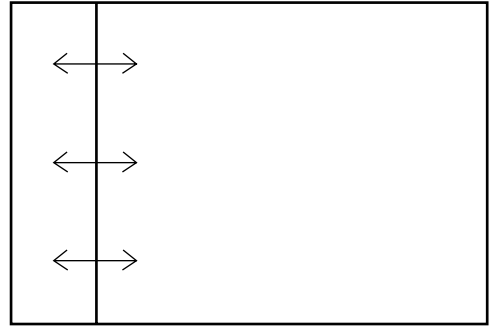
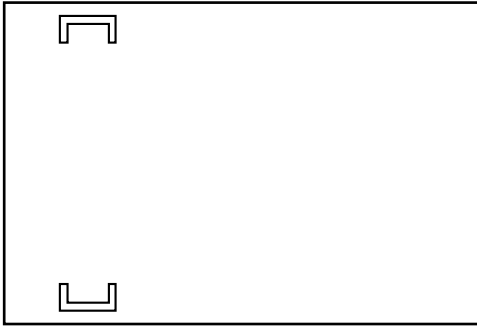

ADJUSTMENTS

In 5, observe the external part of the screen, adjust the 16 adjusting points there, taking note of linearity in the peripheral area such as joining with other screens, crosshatch, etc. (Ignore the distortion inside the screen.)

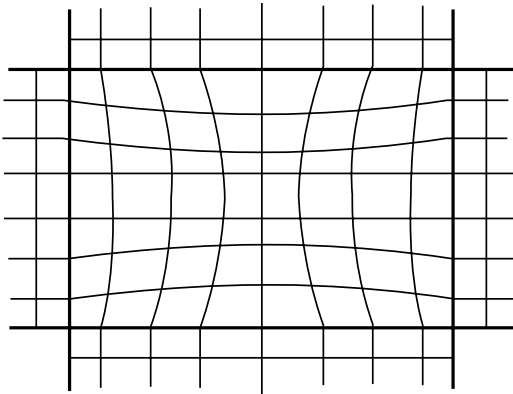
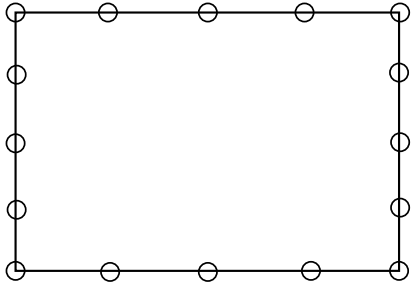

In 6, adjust the inside of the screen and produce linearity.

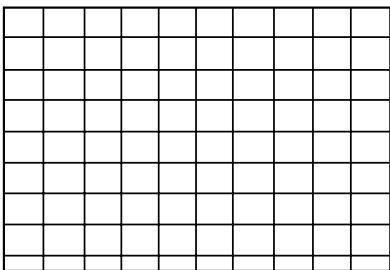

The following are examples of adjusting points in point convergence adjustments and their movements on the screen.

Displayed OSD

Movement on screen

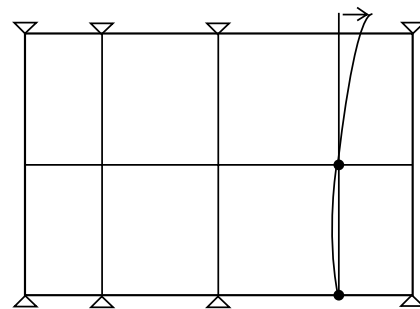
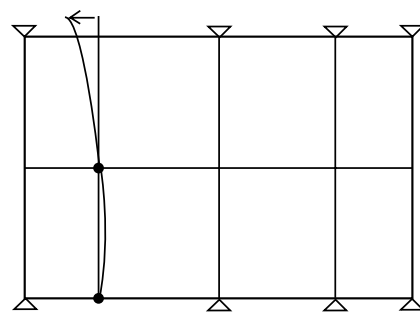
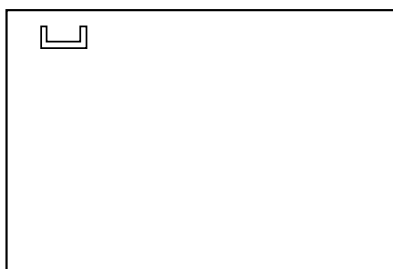
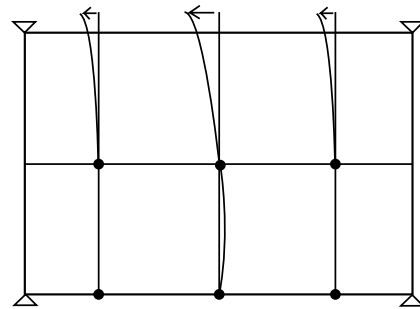
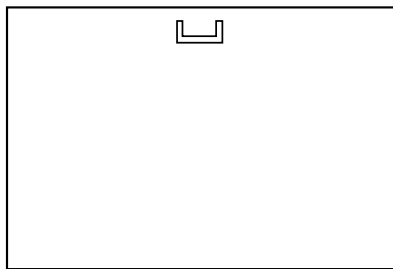
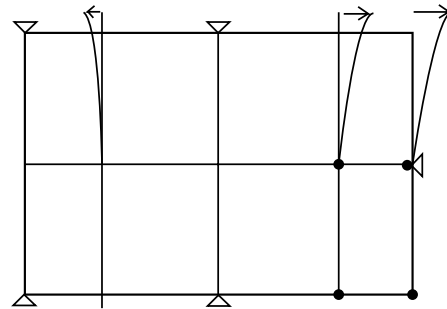
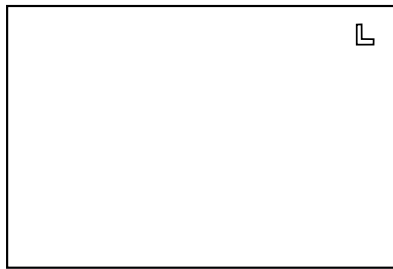
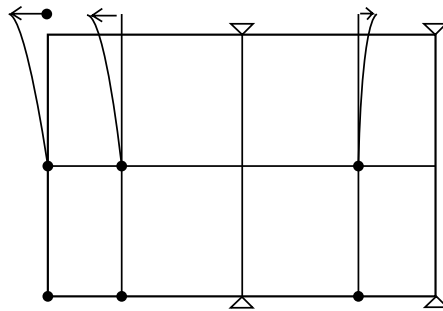
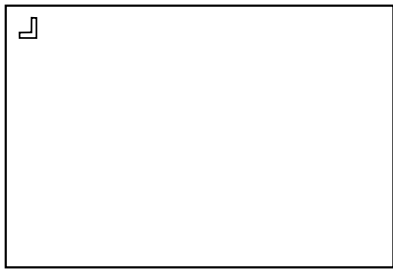

ADJUSTMENTS

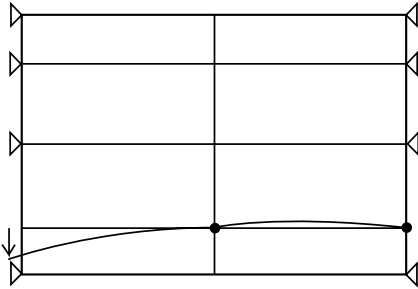
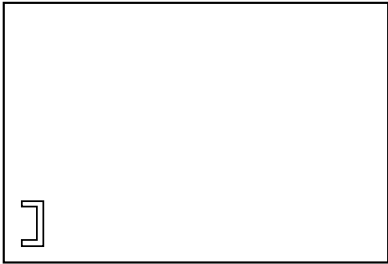
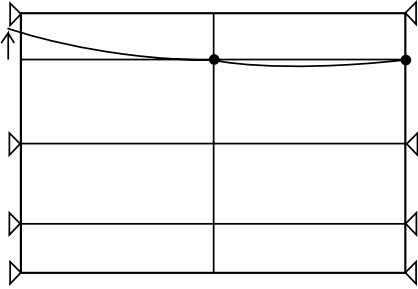
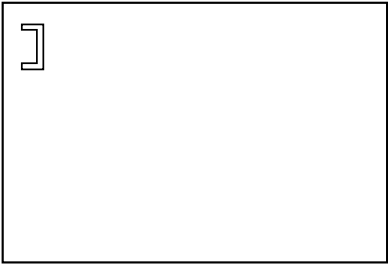
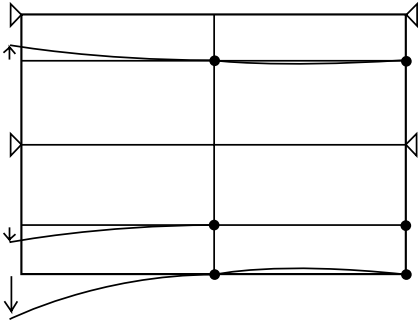
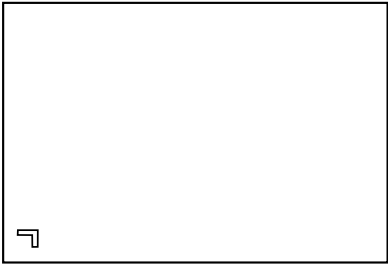
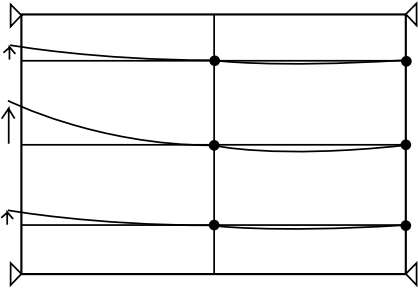
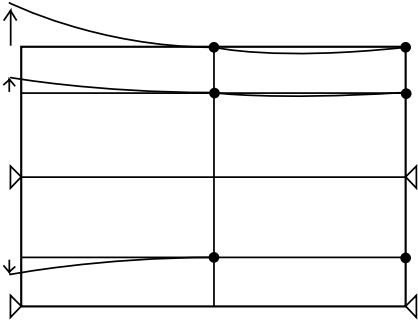
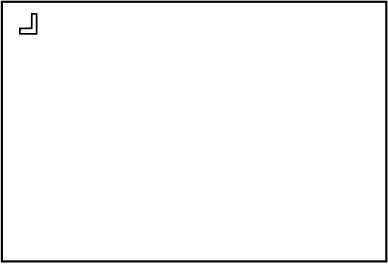

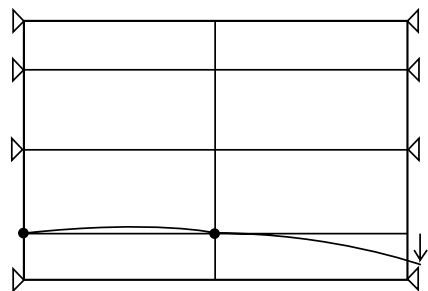
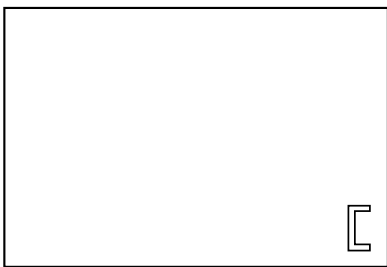
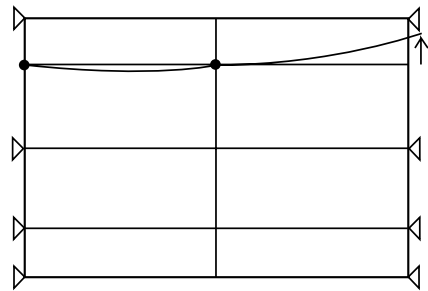
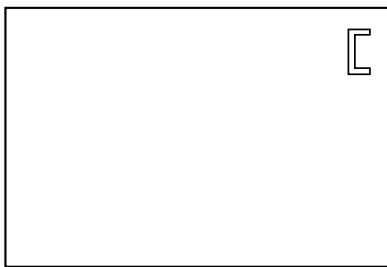
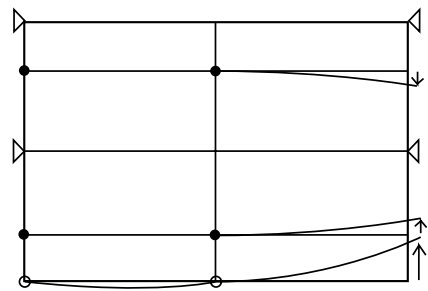
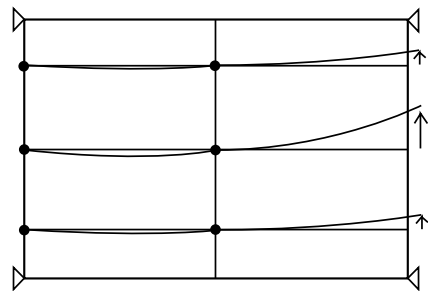
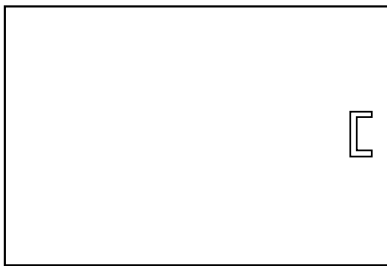
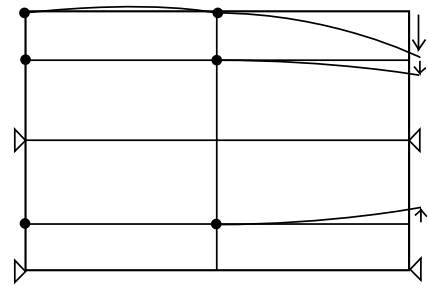
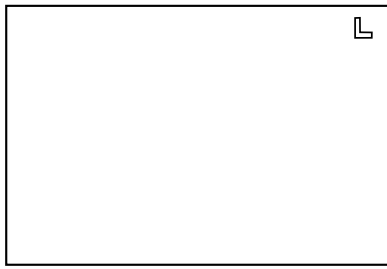

ADJUSTMENTS

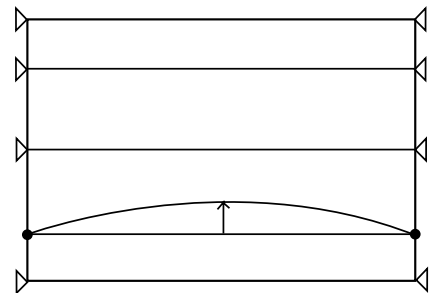
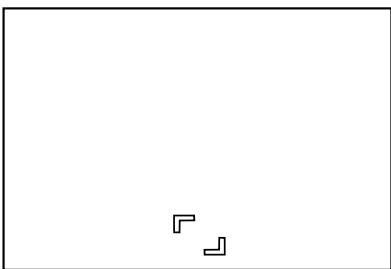
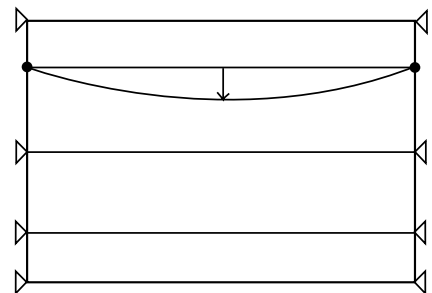
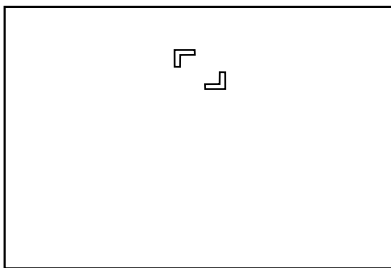
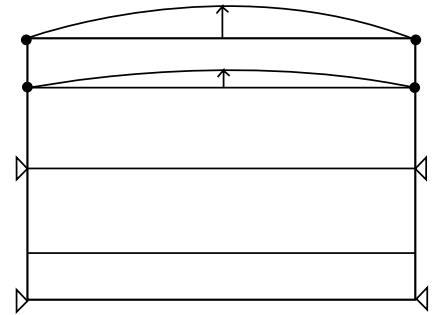
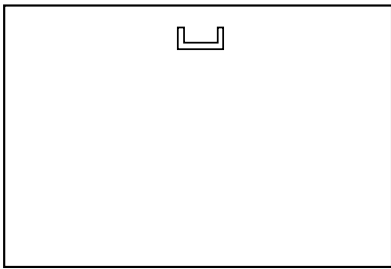
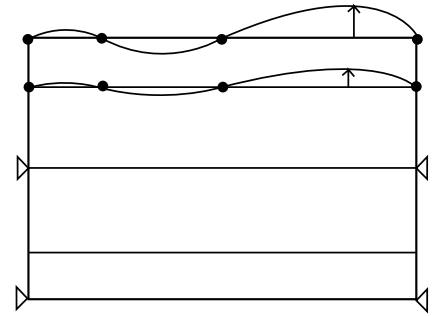
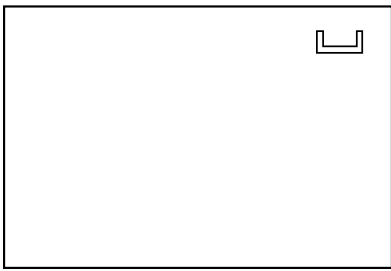
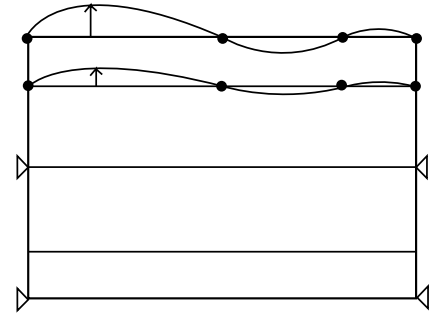
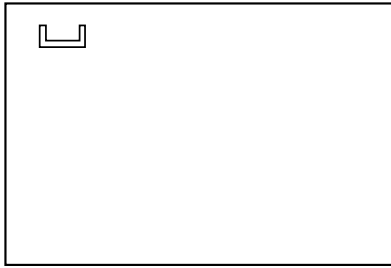

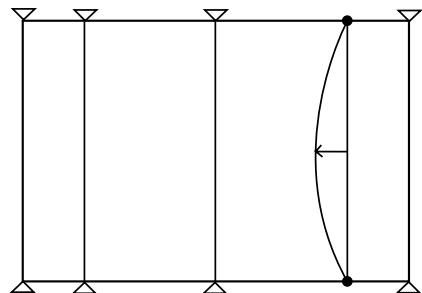
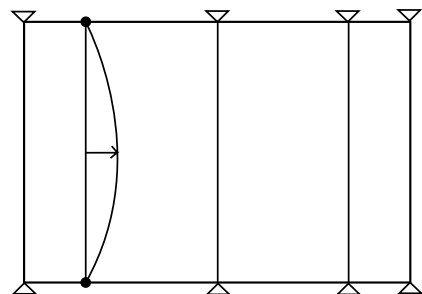
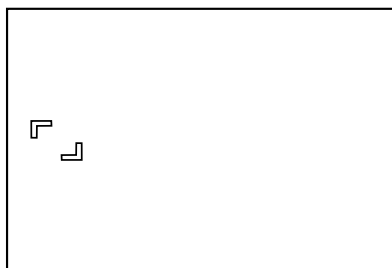
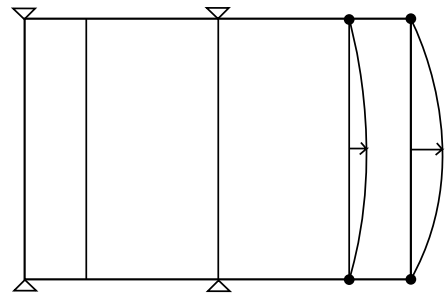
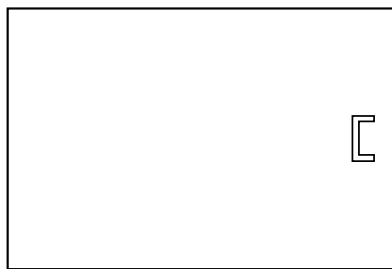
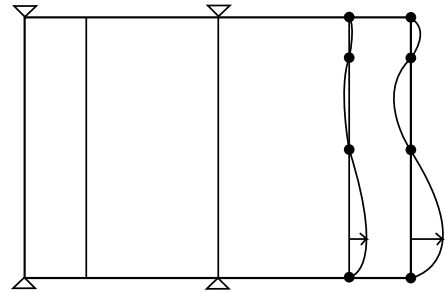
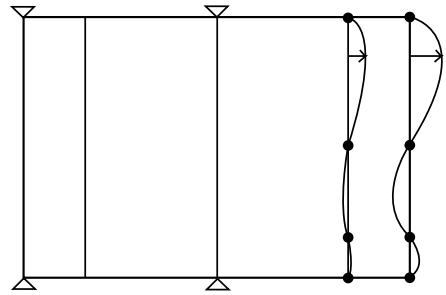
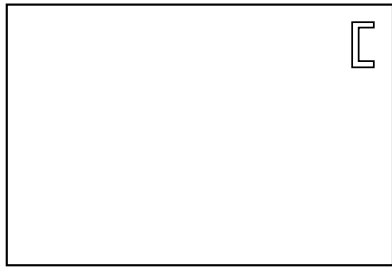

ADJUSTMENTS

NOTE

*If only one point is moved greatly in the point convergence mode, it may not move in areas smaller than the desired adjusting area.
In this case, adjust while moving the other points slowly.*

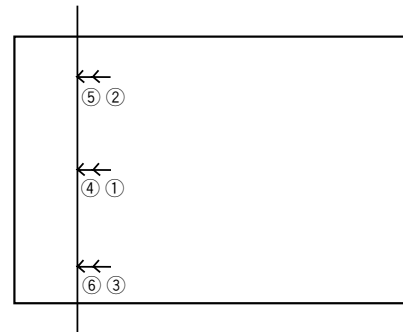
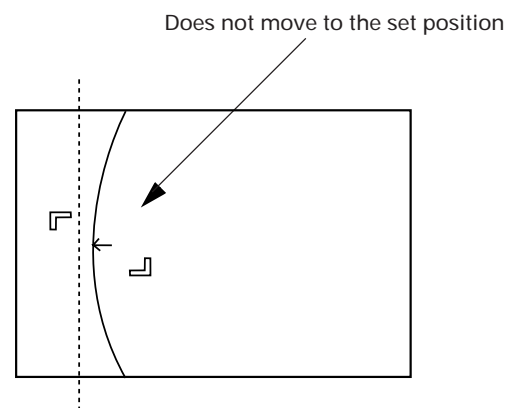

5' Dynamic convergence

In addition to the point convergence mode, conventional convergence adjustments can also be performed.

V • Convergence adjustment

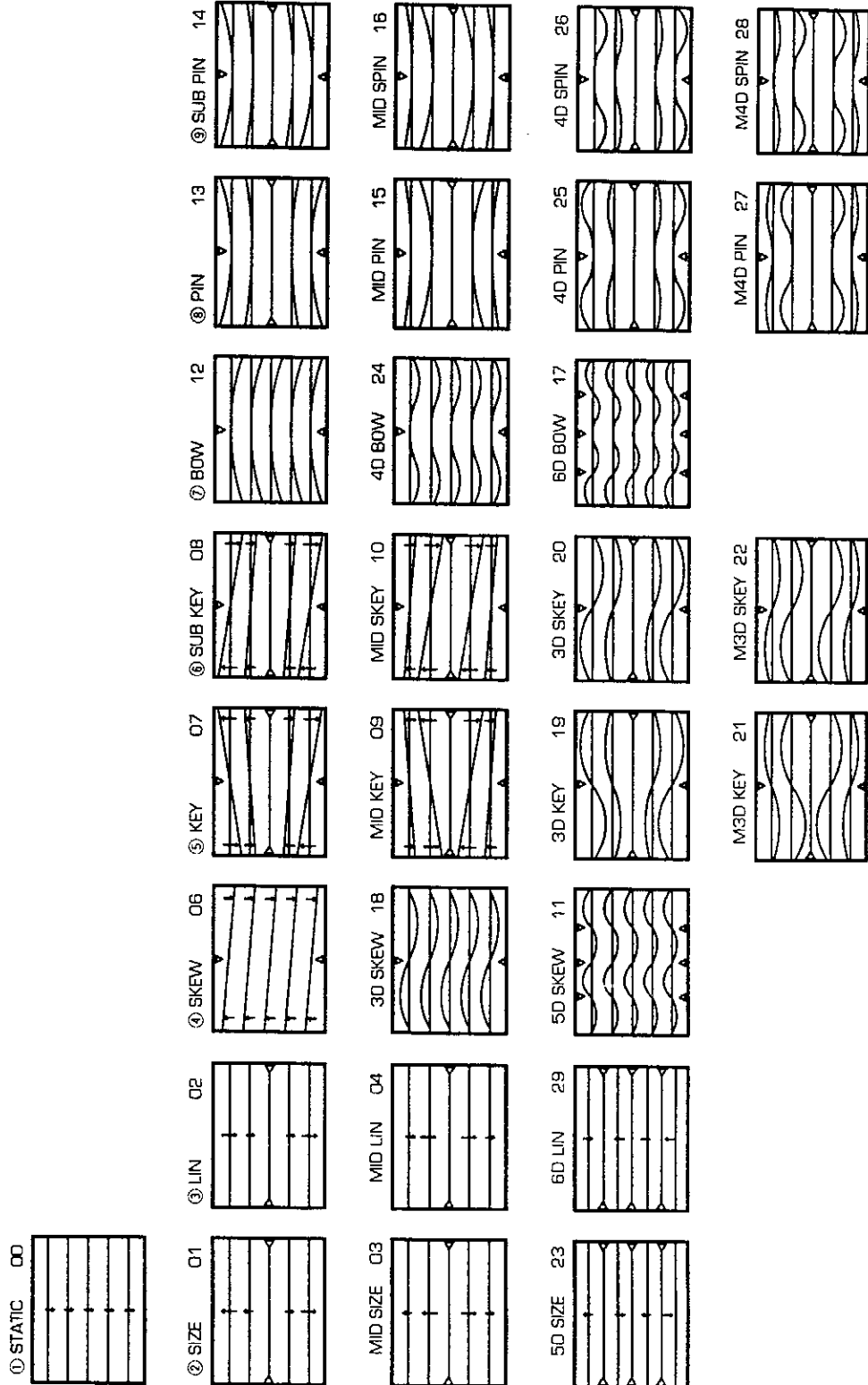

5) Dynamic convergence

H • Convergence adjustment

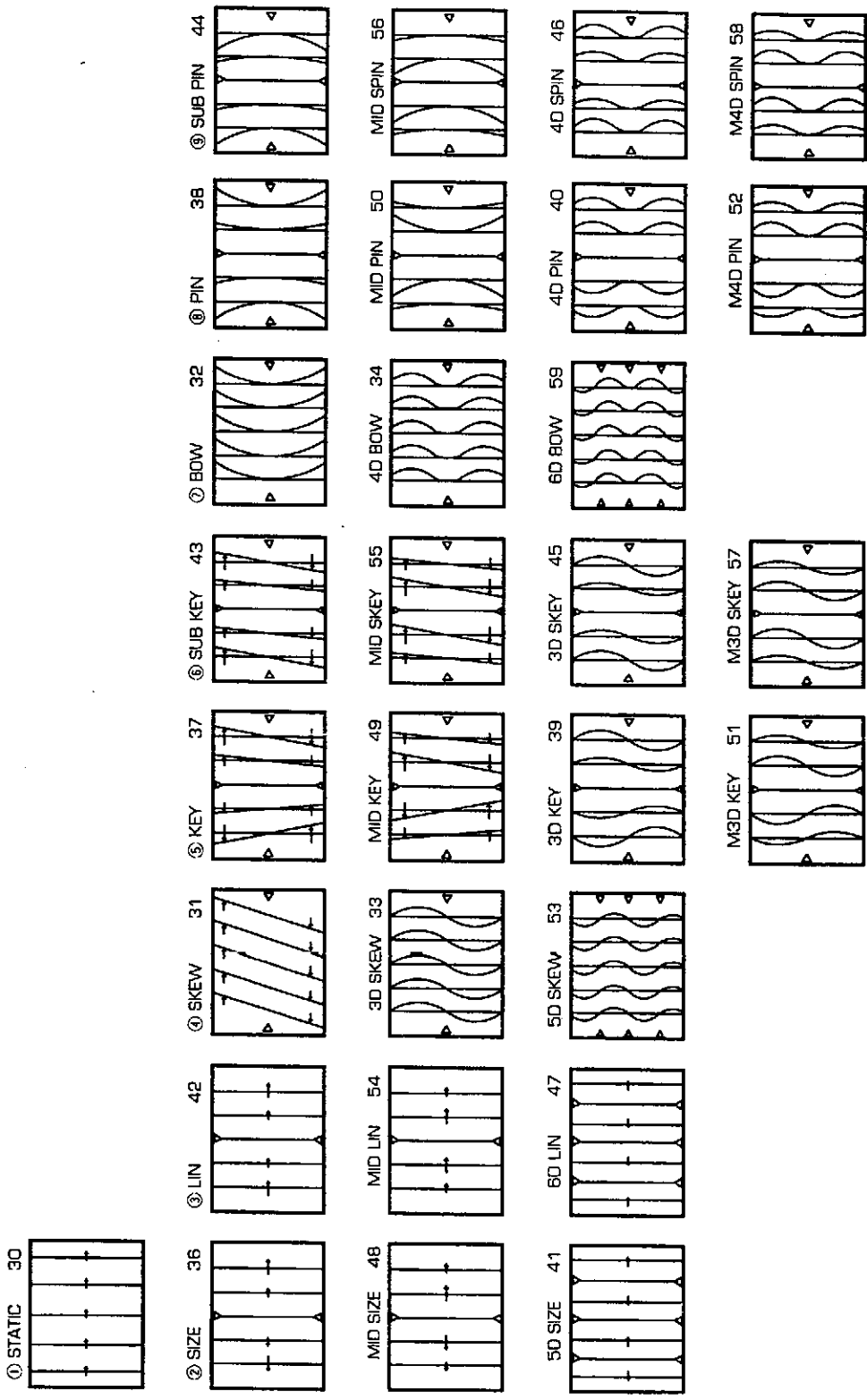

8 H BLK L and H BLK R Adjustments

H BLK L and H BLK R adjustments are performed to obtain the optimum convergence adjustment wave form when the display range changes due to changes in the H SIZE.

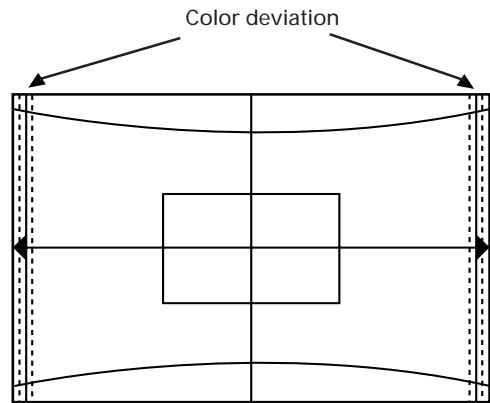
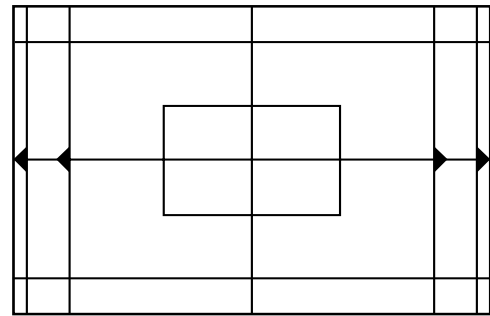
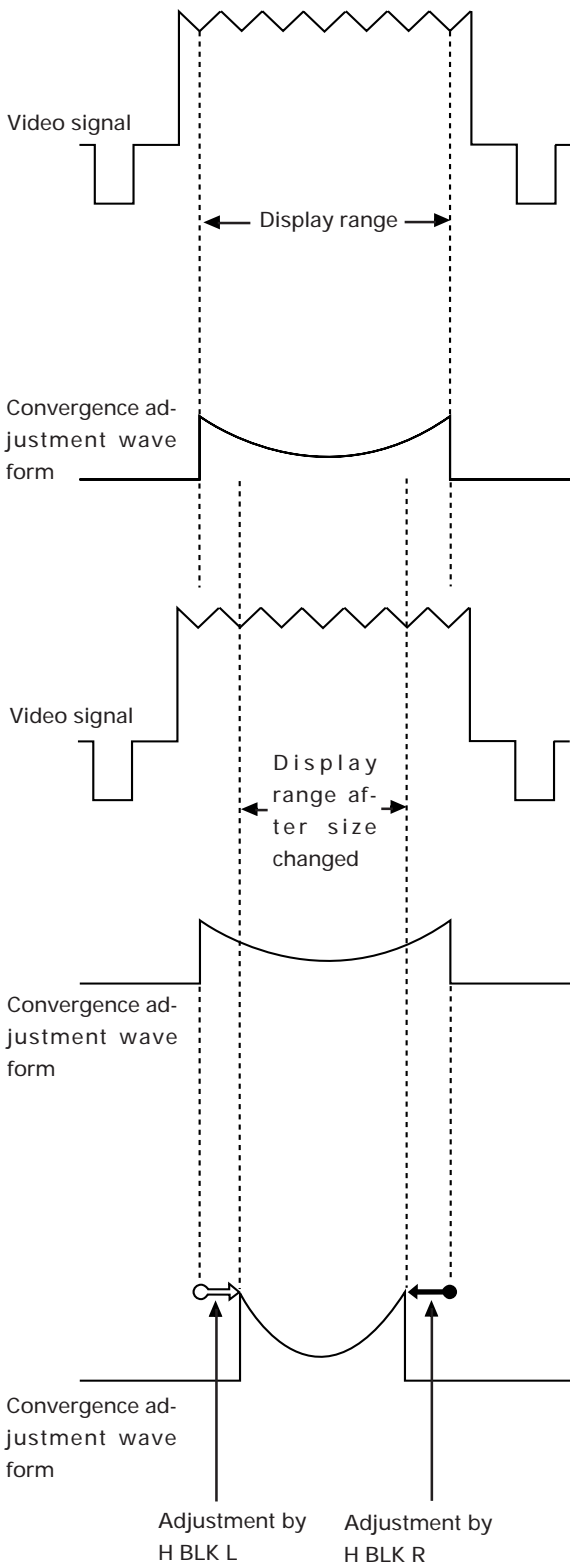

When size is increased with H BLK L and H BLK R not adjusted.

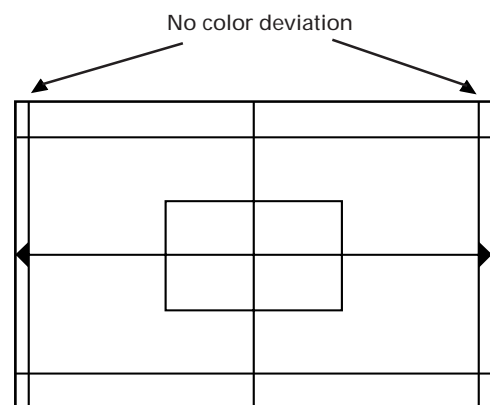
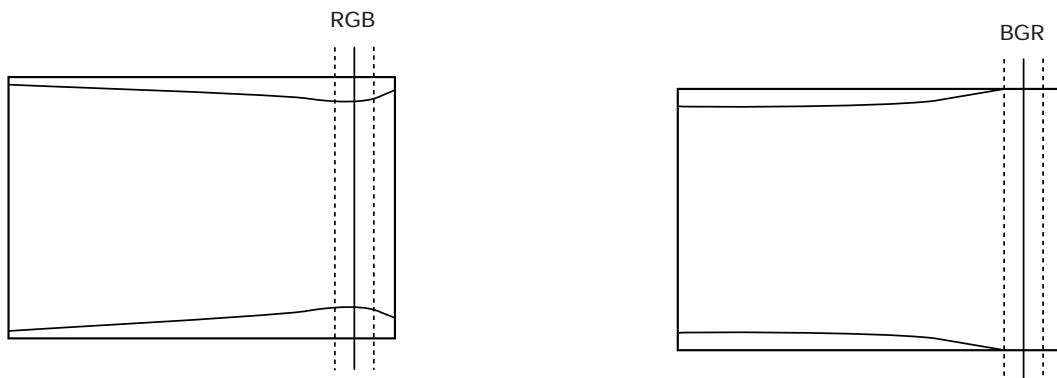
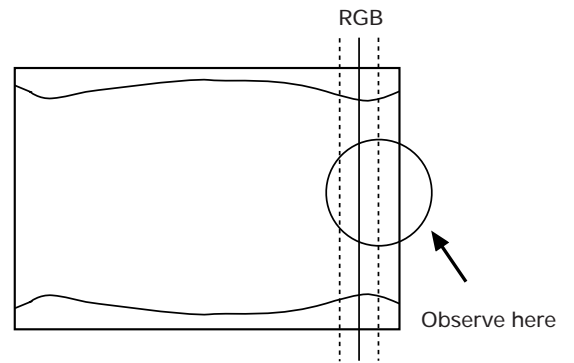

Image after H BLK L and H BLK R has been adjusted.

ADJUSTMENTS

H BLK R Adjustment

Output all three colors R, G, B, observe the right side of the screen, and adjust with **H BLK R** so that the color stops deviating.



When **H BLK R** adjustment is not properly performed

H BLK L adjustment

Output all three colors R, G, B, observe the left side of the screen, and adjust with **H BLK L** so that the color stops deviating.

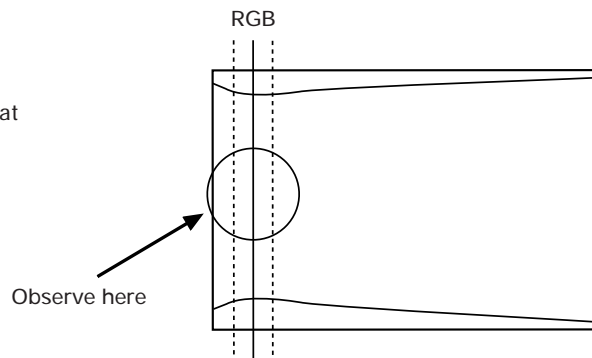

NOTE

There are points at which the screen does not move even through the **H BLK L** value changes. This is not a malfunction.

Confirming the Optimum H BLK L, H BLK R Values

Optimum H BLK R value

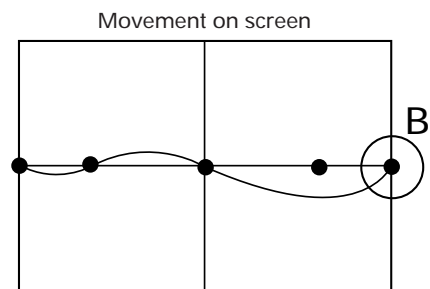
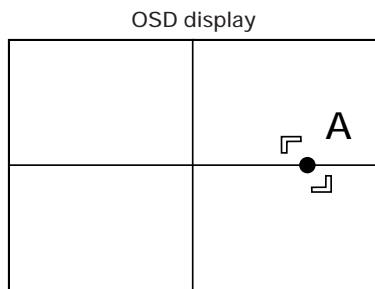

When point A is lowered by point convergence, point B should not move.

Confirming the Optimum H BLK L Value

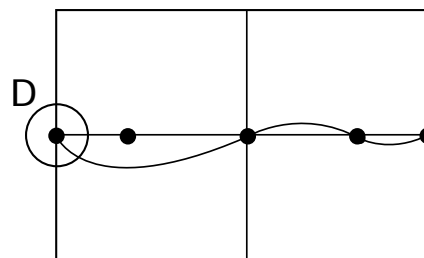
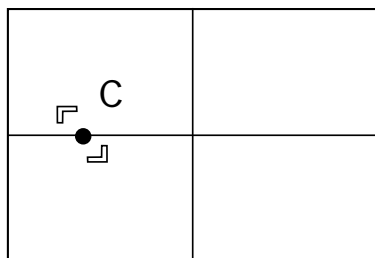

When point C is lowered by point convergence, point D should not move.

Note

Convergence can be adjusted even if the optimum values are slightly different from the above optimum values during adjustments.

But, if the screen changes markedly, re-adjust H BLK L or H BLK R, and adjust the convergence.

ADJUSTMENTS

(4) White Balance Adjustment Flowchart

- When adjusting the multiprojection unit Initial setting Multi on
ABL switching setting (Refer to (5) White Balance Adjustment)
- ① White Balance Adjustment (COMBI OFF)

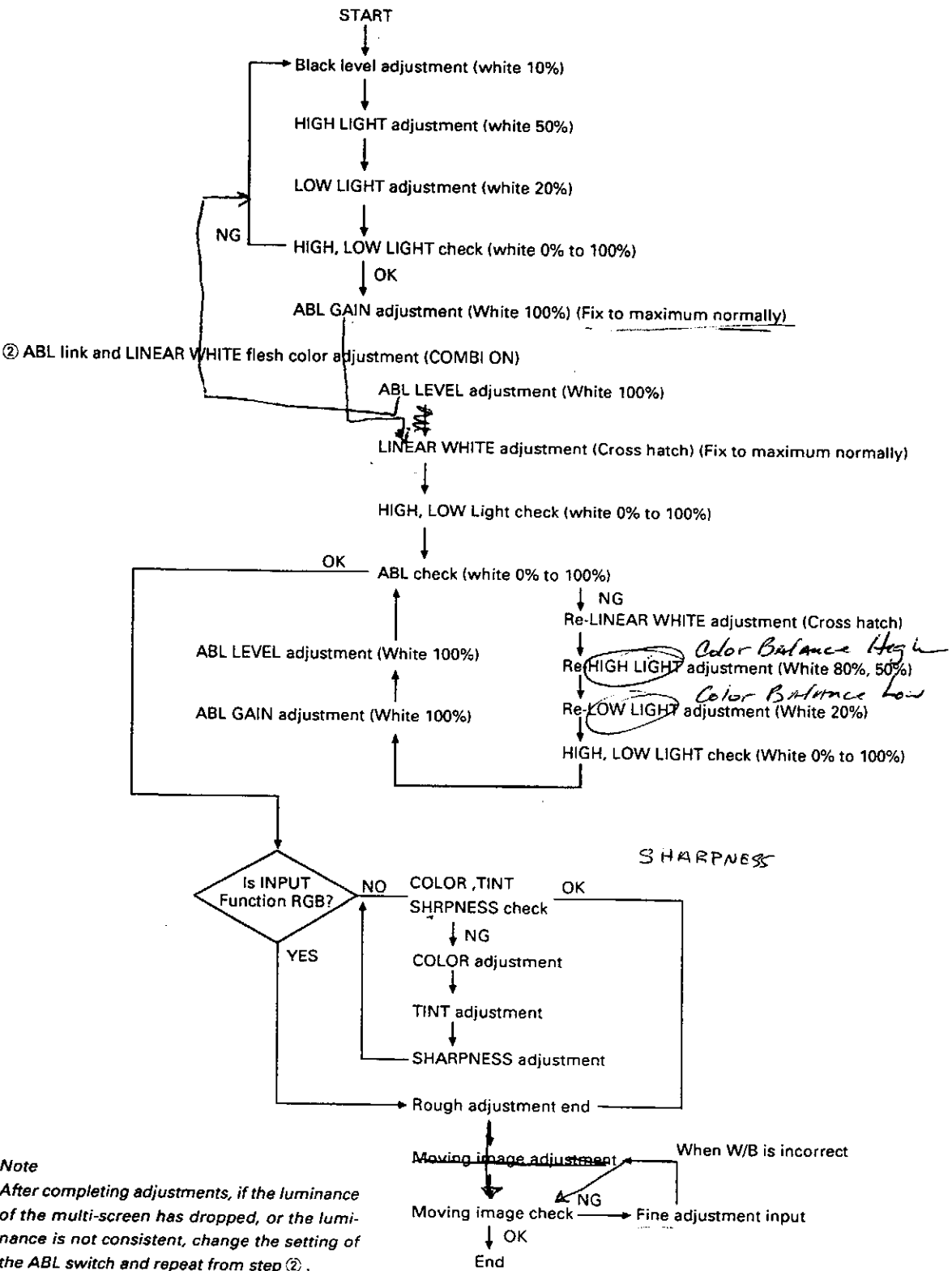

Note
After completing adjustments, if the luminance of the multi-screen has dropped, or the luminance is not consistent, change the setting of the ABL switch and repeat from step ②.

(5) White Balance Adjustment

① Before Adjusting White Balance

Adjusting the white balance means to adjust the color tone. This adjustment is necessary for the screen to become white when the white signal is input, and black when the black signal is input. In the actual adjustment, the bias and gain of the CRTs for the three colors (R, G, and B) are adjusted so that the screen becomes the same color tone.

Before performing the white balance adjustment, complete the convergence adjustment first. If not performed properly especially where the screens join each other, the colors of the screens may not join. When performing the adjustment, take into account the position and height of the sets, height of the eyes of those viewing the screens, and distance to the screens. There are two types of screen white balance data-video, Y/C input and RGB input. The data is switched when the screens are switched. For RGB input, COLOR, TINT, and SHARPNESS cannot be adjusted. When the ABL is OFF, ABL LEVEL cannot be adjusted.

NOTE * : In the PAL signal, TINT cannot be adjusted even in the video or Y/C input .

② ABL switch Setting

In ABL setting, when the luminance of units completely match the unit which ABL voltage is controlled the most and luminance is lowest, the luminance of the whole multi-screen becomes low.

The ABL switch is able to switch the amount of ABL control voltage when ABL is on.

This switch has three modes-ABL1, ABL2, and ABL3.

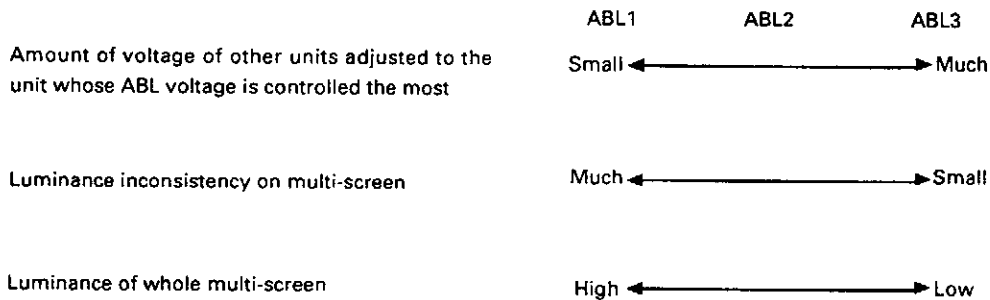

◎Recommended Usage of Modes



At shipment, the ABL switch will be set to ABL3.

ADJUSTMENTS

③ Adjustment Flow

Single screen

- [1] Perform the adjustment using the full white (variable by %) signal generator.
- [2] Perform the COLOR, TINT, and SHARPNESS adjustments.
- [3] Note down or memorize in the PC memory the data after the rough adjustment.
- [4] Check the joining of the screens using the animated images.
- [5] If the screens are not joined properly, adjust. (Check with animated images.)
- [6] If not joined properly, return to the data in (2) and perform the adjustment again.

④ Initial Settings

CONTRAST	128
BRIGHTNESS	128
ABL GAIN	MAX (255)
ABL LEVEL	128
LINEAR WHITE	MAX (255)

R,G,B,HIGH LIGHT

R,G,B,LOW LIGHT

* SHARPNESS

* TINT

* COLOR

} Data at shipment

* Must be set only for VIDEO and Y/C input.

TINT adjustment cannot be performed for PAL inputs

- CONTRAST, LINEAR WHITE, ABL LEVEL, ABL GAIN adjustment values considerably affect the ABL operation. Fix the initial value for ordinary use.
- Perform the W/B adjustment in the order of R/G/B HIGH LIGHT and R/G/B LOW LIGHT. (Fix the CONTRAST and BRIGHTNESS.)
Change the HIGH LIGHT luminance using G HIGH LIGHT and the LOW LIGHT luminance using G LOW LIGHT.
- Basically, fix the CONTRAST level to 128, if the ABL function feature well.

⑤ Rough Adjustments

(1) Black level adjustment

Signal: White 10%

Adjust R LOW, G LOW, and B LOW to the point where the CRT starts lighting up.

(2) HI LIGHT adjustment

Signal: White 50%

Adjust R HI, G HI, and B HI so that the CRT becomes white. First, adjust so that the brightness of R, G, and B becomes the same, and while maintaining that brightness, balance R, G, and B, and adjust so that the CRT becomes white.

(3) LOW LIGHT adjustment

Signal: White 20%

Adjust R LOW, G LOW, and B LOW so that the CRT becomes gray.

(4) Convergence adjustment

Signal: White 50%, 20%

Repeat (2) to (3) and converge the light. If the HI LIGHT of R, G, and B is moved, their LOW LIGHT will change greatly. Therefore, pay special attention to the value of the LOW LIGHT.

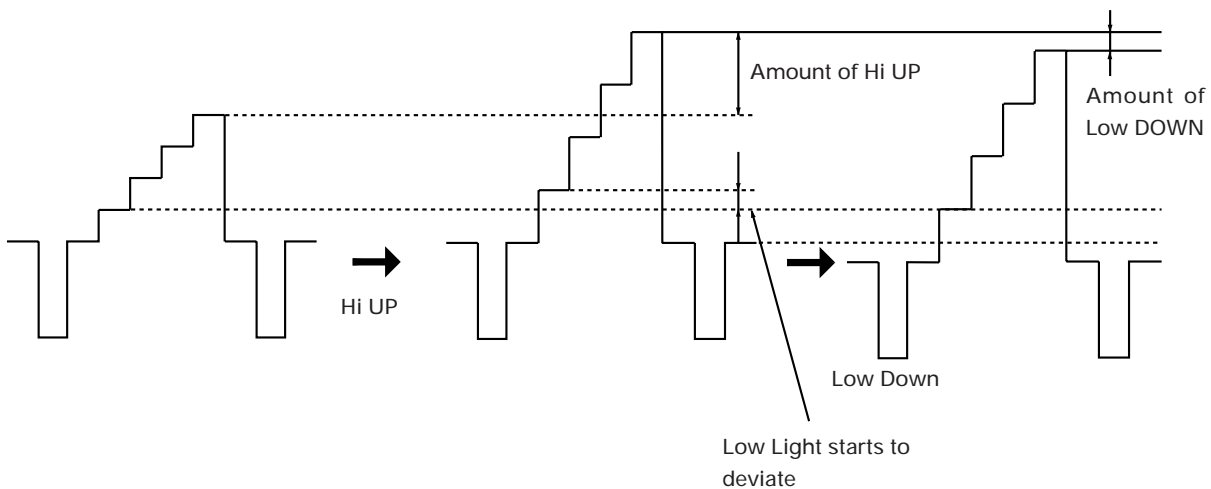

ADJUSTMENTS

⑥ LINEAR WHITE adjustment

When white peak signals such as WINDOW are input, due to the characteristics of the Blue CRT, there is a tendency for the peak to become yellow compared to other colors. The linear white adjustment is performed to correct this tendency.

Blue becomes weak when data is set to UP and strong when set to DOWN. If Linear White is added excessively, the ABL voltage becomes unbalanced and the medium luminance of blue may be erased, etc.

Also make sure that the blue is not blur when MULTI ON is set because the top left and bottom left of the screen are affected first.

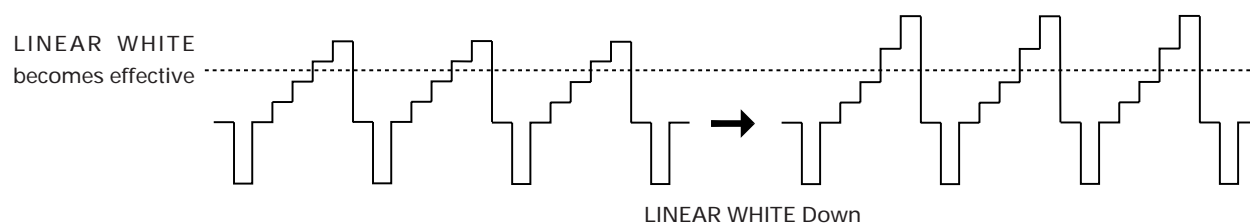

⑦ ABL GAIN adjustment (White 100%)

The ABL GAIN adjustment adjusts the white 100% luminance of a unit to other units after low luminance and medium luminance have been adjusted.

Normally, when white 100% is input, ABL is imposed and the current is controlled so that the current flowing in the CRT does not exceed a certain level. Even if the current flowing in the CRT of each unit is the same, the difference in the characteristics of each CRT will cause their luminance to become inconsistent. The ABL GAIN adjustment converges this inconsistency. It adjusts the ABL current flowing virtually.

In white 100% inputs, as the ABL works efficiently, the luminance drops, when the ABL GAIN of a unit with high luminance is decreased, use this adjustment to adjust its luminance to the other units.

Turn off the ABL in the adjustment.

Normally set the ABL GAIN to maximum.

⑧ ABL LEVEL adjustment (White 100%)

The ABL LEVEL adjustment controls the inconsistency of the ABL control voltage of each unit when ABL is on.

- [1] Set the ABL of all units to ON.
- [2] Turn on and off the ABL of each unit to change the luminance.
- [3] For units whose luminance becomes dark when ABL is ON, turn UP the ABL level and set to the point where the luminance stops changing by turning on and off the ABL.
- [4] For units whose luminance does not change, turn DOWN the ABL level to the point just before the luminance becomes dark.
- [5] Perform steps (2) to (4) for all the units, change white from 0 to 100% and check that the ABL does not work abnormally.

⑨ Adjustment Using Moving Images

The adjustment using images adjusts the overall joining of the screens by loading discs used by users (for actual performance) and discs always used for adjustments. View the overall screen and adjust the screen with the greatest difference to the other screens. The specific method is; at first, focus on the brightness, make the brightness the same, and correct the differences in R, G, and B. Pay the attention that changing the HI LIGHT value affects the balance of the LOW LIGHT considerably. Strictly speaking, as W/B deviation cannot be checked using moving images and W/B cannot be corrected just by performing fine adjustments, check using rough adjustments.

If the DEMONSTRATION-II LD can be used, correct the following points.

[1] Dark images (Almost black image:FRAME No. 32300 to 33200)

Check that the brightness of the screens appears the same.
Check that black is not blur or emphasized.

[2] Bright images (Almost white image:FRAME NO. 7400 to 8100)

Focus on where the brightness is the same, especially the white peak, and check in the same way as for dark images in (1).

[3] Skin color images (FRAME NO. 26900)

Check if the skin color of a face image is the same as in the other screens.

[4] Colored images (FRAME NO. 19100)

Use when performing adjustments during VIDEO input or Y/C input. Adjust so that the colors of vegetables, fruits, etc. are of the same brightness and same depth.

If consistency cannot be adjusted with animated images, re-input the rough adjustment data and re-adjust.

*View the moving images. If a screen is darker than the others due to excessive ABL, increase the contrast and decrease the R, G, B High Light so that ABL is suppressed.

[5] White peak images (FRAME NO.08272)

Readjust the Linear White adjustment, if the whiteness on the white peak screen differed on each screen.

⑩ Confirm the moving images

View the moving images. If W/B is incorrect, set to rough adjustment. If the luminance of the multi-screen is dark or inconsistent, set the ABL switch.

⑪ Precautions

[1] Avoid adjusting with images with high tube radiation (FRAME NO. 13590)

If only one spot is bright in a very dark image, the screen will look bright due to the spot.

[2] Precautions on screen hue

If the hue of the screens is green or yellow, images will not be displayed clearly. The white parts of bright images especially will appear yellow. These images can be made clear by adjusting so that they appear slightly bluish.

However, if made bluish excessively, brightness may appear insufficient due to the CRT characteristics.

ADJUSTMENTS

3 Color Adjustment (White Balance)

(a) Effects of brightness

- Take note of dark images which have some high luminance parts.
- The reflected light overlap with surrounding dark parts at the face of the CRT and surface of projection lens, and luminance and hue become different from the adjoining screen.

(b) Differences caused by visual points

- Although the joined parts of multiple screens are improved by peripheral light amount correction, the image may not be natural at some points. (Adjustment of vertical direction using the installation table)
- Due to the layout of the red, green, and blue CRTs, when the screens are viewed diagonally, they may appear reddish or bluish (Color shift).
- For multiple screens, as the angles of the left and right screens are different to a viewer, they may appear to have different colors.

◎ Before adjustments, check the user's visual point, and adjust at that point.

(c)

- Because the white balance is adjusted using high light (drive) and low light (cutoff), the red, green, and blue may not be balanced at the mid-range of luminance. In this case, adjust R, G, B, LOW LIGHT or R, G, B, HIGH LIGHT at the mid-range, and make the balance of these colors consistent from low luminance to high luminance.

(6) External Control by RS-232C

As Multi projection unit is equipped with a RS-232C port, various controls and, white balance and convergence adjustments can be performed by an external computer.

By programming software ,it is possible not only to adjust White Balance,Convergence but to save and control the adjustment data of each source.

① Interface

- 1]Connector
D-sub 25-pin
- 2]Pin assignment

PIN No.	Symbo;	Signal Name
1	FG	Frame Ground
2	RXD	Received Data
3	TXD	Transmitted Data
5	CTS	Clear To Send
7	GND	Signal Ground

- [3]Baud rate
4800 bps (1200, 2400, 9600, 19200 bps can also be selected)

- [4]Data format
Start:1-bit
Data:8-bit
Parity:0 (No parity)
Stop:1-bit

- [5]Connection

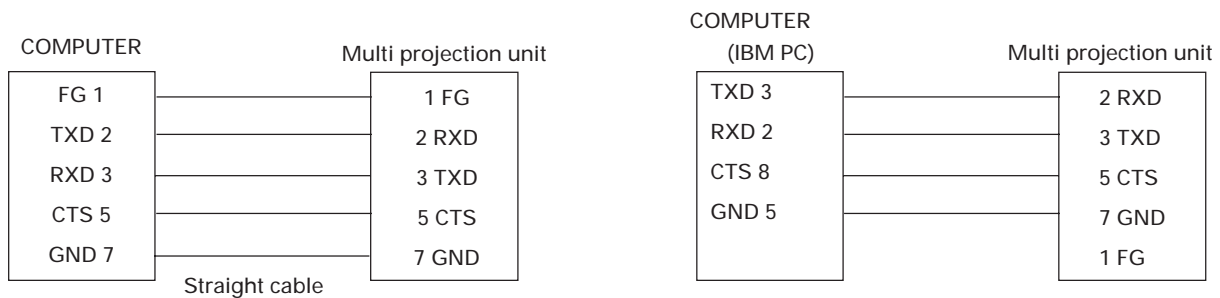

- [6]Protocol
Multi projection unit from computer

ID : 2-Byte(ASC II)COMMAND : 3-Byte(ASC II)
stx=02h etx=03h

stx	ID	COMMAND	etx
-----	----	---------	-----

stx	ID	COMMAND	COMMAND	COMMAND	etx	Up to 3 commands possible
-----	----	---------	---------	---------	-----	---------------------------

stx	ID	COMMAND	ARGUMENT	etx	*
-----	----	---------	----------	-----	---

ARGUMENT : 3-Byte(ASC II)
Note : * In case of the numeral direct command

ADJUSTMENTS

② RS-232C Commands Table

	Command	Name	Normal Valid	Number Direct	UP/DW Command	Function
A	ABL	ABL LEVEL	×	○	○	ABL operation link level adjustment (Note 1)
	AJN	ADJUST NO	×	×	×	Adjustment mode exit
	AJY	ADJUST YES	○	×	×	Adjustment mode start-up
	AOF	ALL OFF	○	×	×	R,G,B all color off
	AON	ALL ON	○	×	×	R,G,B all color on
	ABG	ABL GAIN	×	○	○	ABL gain adjustment
B	B00	BLUE 00	×	○	○	Adjusts BV STATIC
	B01	BLUE 01	×	○	○	Adjusts BV SIZE
	B02	BLUE 02	×	○	○	Adjusts BV LINEARITY
	B03	BLUE 03	×	○	○	Adjusts MID SIZE
	B04	BLUE 04	×	○	○	Adjusts MID LIN
	B06	BLUE 06	×	○	○	Adjusts BV SKEW
	B07	BLUE 07	×	○	○	Adjusts BV KEY
	B08	BLUE 08	×	○	○	Adjusts BV SUB KEY
	B09	BLUE 09	×	○	○	Adjusts BV MID KEY
	B10	BLUE 10	×	○	○	Adjusts BV MID S-KEY
	B11	BLUE 11	×	○	○	Adjusts BV 5D SKEW
	B12	BLUE 12	×	○	○	Adjusts BV BOW
	B13	BLUE 13	×	○	○	Adjusts BV PIN
	B14	BLUE 14	×	○	○	Adjusts BV SUB PIN
	B15	BLUE 15	×	○	○	Adjusts BV MID PIN
	B16	BLUE 16	×	○	○	Adjusts BV MID S-PIN
	B17	BLUE 17	×	○	○	Adjusts BV 6D BOW
	B18	BLUE 18	×	○	○	Adjusts BV 3D SKEW
	B19	BLUE 19	×	○	○	Adjusts BV 3D KEY
	B20	BLUE 20	×	○	○	Adjusts BV 3D SUB KEY
	B21	BLUE 21	×	○	○	Adjusts BV MID 3D KEY
	B22	BLUE 22	×	○	○	Adjusts BV MID 3D S-KEY
	B23	BLUE 23	×	○	○	Adjusts BV 5D SIZE
	B24	BLUE 24	×	○	○	Adjusts BV 4D BOW
	B25	BLUE 25	×	○	○	Adjusts BV 4D PIN
	B26	BLUE 26	×	○	○	Adjusts BV 4D SUB PIN
	B27	BLUE 27	×	○	○	Adjusts BV MID 4D PIN
	B28	BLUE 28	×	○	○	Adjusts BV MID 4D S-PIN
	B29	BLUE 29	×	○	○	Adjusts BV 6D LIN
	B30	BLUE 30	×	○	○	Adjusts BH STATIC
	B31	BLUE 31	×	○	○	Adjusts BH SKEW
	B32	BLUE 32	×	○	○	Adjusts BH BOW
	B33	BLUE 33	×	○	○	Adjusts BH 3D SKEW
	B34	BLUE 34	×	○	○	Adjusts BH 4D BOW
	B36	BLUE 36	×	○	○	Adjusts BH SIZE
	B37	BLUE 37	×	○	○	Adjusts BH KEY
	B38	BLUE 38	×	○	○	Adjusts BH PIN

ADJUSTMENTS

Command	Name	Normal Valid	Number Direct	UP/DW Command	Function
B39	BLUE 39	X	○	○	Adjusts BH 3D KEY
B40	BLUE 40	X	○	○	Adjusts BH 4D PIN
B41	BLUE 41	X	○	○	Adjusts BH 5D SIZE
B42	BLUE 42	X	○	○	Adjusts BH LINEARITY
B43	BLUE 43	X	○	○	Adjusts BH SUB KEY
B44	BLUE 44	X	○	○	Adjusts BH SUB PIN
B45	BLUE 45	X	○	○	Adjusts BH 3D S-KEY
B46	BLUE 46	X	○	○	Adjusts BH 4D S-PIN
B47	BLUE 47	X	○	○	Adjusts BH 6D LIN
B48	BLUE 48	X	○	○	Adjusts BH MID SIZE
B49	BLUE 49	X	○	○	Adjusts BH MID KEY
B50	BLUE 50	X	○	○	Adjusts BH MID PIN
B51	BLUE 51	X	○	○	Adjusts BH MID 3D KEY
B52	BLUE 52	X	○	○	Adjusts BH MID 4D PIN
B53	BLUE 53	X	○	○	Adjusts BH 5D SKEW
B54	BLUE 54	X	○	○	Adjusts BH MID LIN
B55	BLUE 55	X	○	○	Adjusts BH MID SUB KEY
B56	BLUE 56	X	○	○	Adjusts BH MID SUB PIN
B57	BLUE 57	X	○	○	Adjusts BH MID 3D S-KEY
B58	BLUE 58	X	○	○	Adjusts BH MID 4D S-PIN
B59	BLUE 59	X	○	○	Adjusts BH 6D BOW
B61	P-CONV. ADJ 61	X	X	(Note 2)	Adjusts BLUE point convergence
B62	P-CONV. ADJ 62	X	X	(Note 2)	Adjusts BLUE point convergence
B63	P-CONV. ADJ 63	X	X	(Note 2)	Adjusts BLUE point convergence
B64	P-CONV. ADJ 64	X	X	(Note 2)	Adjusts BLUE point convergence
B65	P-CONV. ADJ 65	X	X	(Note 2)	Adjusts BLUE point convergence
B71	P-CONV. ADJ 71	X	X	(Note 2)	Adjusts BLUE point convergence
B72	P-CONV. ADJ 72	X	X	(Note 2)	Adjusts BLUE point convergence
B73	P-CONV. ADJ 73	X	X	(Note 2)	Adjusts BLUE point convergence
B74	P-CONV. ADJ 74	X	X	(Note 2)	Adjusts BLUE point convergence
B75	P-CONV. ADJ 75	X	X	(Note 2)	Adjusts BLUE point convergence
B81	P-CONV. ADJ 81	X	X	(Note 2)	Adjusts BLUE point convergence
B82	P-CONV. ADJ 82	X	X	(Note 2)	Adjusts BLUE point convergence
B83	P-CONV. ADJ 83	X	X	(Note 2)	Adjusts BLUE point convergence
B84	P-CONV. ADJ 84	X	X	(Note 2)	Adjusts BLUE point convergence
B85	P-CONV. ADJ 85	X	X	(Note 2)	Adjusts BLUE point convergence
B91	P-CONV. ADJ 91	X	X	(Note 2)	Adjusts BLUE point convergence
B92	P-CONV. ADJ 92	X	X	(Note 2)	Adjusts BLUE point convergence
B93	P-CONV. ADJ 93	X	X	(Note 2)	Adjusts BLUE point convergence
B94	P-CONV. ADJ 94	X	X	(Note 2)	Adjusts BLUE point convergence
B95	P-CONV. ADJ 95	X	X	(Note 2)	Adjusts BLUE point convergence
BA1	P-CONV. ADJ A1	X	X	(Note 2)	Adjusts BLUE point convergence
BA2	P-CONV. ADJ A2	X	X	(Note 2)	Adjusts BLUE point convergence
BA3	P-CONV. ADJ A3	X	X	(Note 2)	Adjusts BLUE point convergence
BA4	P-CONV. ADJ A4	X	X	(Note 2)	Adjusts BLUE point convergence
BA5	P-CONV. ADJ A5	X	X	(Note 2)	Adjusts BLUE point convergence
BP1	P-CONV. ADJ P1	X	X	(Note 2)	Adjusts BLUE point convergence

ADJUSTMENTS

	Com- mand	Name	Normal Valid	Number Direct	UP/DW Command	Function
B	BP2	P-CONV. ADJ P2	×	×	(Note 2)	Adjusts BLUE point convergence
	BP3	P-CONV. ADJ P3	×	×	(Note 2)	Adjusts BLUE point convergence
	BP4	P-CONV. ADJ P4	×	×	(Note 2)	Adjusts BLUE point convergence
	BP5	P-CONV. ADJ P5	×	×	(Note 2)	Adjusts BLUE point convergence
	BP6	P-CONV. ADJ P6	×	×	(Note 2)	Adjusts BLUE point convergence
	BP7	P-CONV. ADJ P7	×	×	(Note 2)	Adjusts BLUE point convergence
	BP8	P-CONV. ADJ P8	×	×	(Note 2)	Adjusts BLUE point convergence
	BP9	P-CONV. ADJ P9	×	×	(Note 2)	Adjusts BLUE point convergence
	BP0	P-CONV. ADJ P9	×	×	(Note 2)	Adjusts BLUE point convergence
	BR1	BAUD RATE 1	×	×	×	Sets RS-232C baud rate to 1200 BPS
	BR2	BAUD RATE 2	×	×	×	Sets RS-232C baud rate to 2400 BPS
	BR3	BAUD RATE 3	×	×	×	Sets RS-232C baud rate to 4800 BPS
	BR4	BAUD RATE 4	×	×	×	Sets RS-232C baud rate to 9600 BPS
	BR5	BAUD RATE 5	×	×	×	Sets RS-232C baud rate to 19200 BPS
	BHI	BLUE HIGH LIGHT	×	○	○	Adjusts BLUE HIGH-LIGHT
	BLW	BLUE LOW LIGHT	×	○	○	Adjusts BLUE LOW-LIGHT
	BOF	BLUE OFF	×	×	×	Turns OFF BLUE
	BON	BLUE ON	×	×	×	Turns ON BLUE
	BRT	BRIGHTNESS	×	○	○	Adjusts BRIGHTNESS
	C	CBN	COMBINATION NO	○	×	×
CBY		COMBINATION YES	○	×	×	Turns ON ABL operation link
CM1		COLOR MODE 1	○	×	×	Sets white balance data to color mode 1
CM2		COLOR MODE 2	○	×	×	Sets white balance data to color mode 2
CNT		CONTRAST	×	○	○	Adjusts CONTRAST
COL		COLOR	×	○	○	Adjusts COLOR (Note 3)
COF		COLOR OFF	×	×	×	Turns OFF COLOR (Note 3)
CON		COLOR ON	×	×	×	Turns ON COLOR (Note 3)
C12		CONV. DATA COPY 1→2	×	×	×	Copy Convergence data MEMO-1 to 2
C13		CONV. DATA COPY 1→3	×	×	×	Copy Convergence data MEMO-1 to 3
C21		CONV. DATA COPY 2→1	×	×	×	Copy Convergence data MEMO-2 to 1
C23		CONV. DATA COPY 2→3	×	×	×	Copy Convergence data MEMO-2 to 3
C31	CONV. DATA COPY 3→1	×	×	×	Copy Convergence data MEMO-3 to 1	
C32	CONV. DATA COPY 3→2	×	×	×	Copy Convergence data MEMO-3 to 2	
D	DOF	DISPLAY OFF	×	×	×	Turns OFF OSD display
	DW0	DOWN 10	×	×	×	Decreases adjusting value by 10
	DWn	DOWN n	×	×	×	Decreases adjusting value by n
	DWF	DOWN FULL	×	×	×	Minimizes adjusting value
	DIY	OSD DISP. YES	×	×	×	Enables OSD display
	DIN	OSD DISP. NO	×	×	×	Disables OSD display
G	G00	GREEN 00	×	○	○	GREEN convergence adjustment (Same as BLUE)
	G59	GREEN 59				

ADJUSTMENTS

	Command	Name	Normal Valid	Number Direct	UP/DW Command	Function
G	G61	P-CONV. ADJ 61	X	O	O	GREEN point convergence adjustment (Same as BLUE)
	GP0	P-CONV. ADJ P0				
	GHI	GREEN HIGH-LIGHT	X	O	O	Adjusts GREEN HIGH-LIGHT
	GLW	GREEN LOW-LIGHT	X	O	O	Adjusts GREEN LOW-LIGHT
	GON	GREEN ON	X	X	X	Turns ON GREEN
	GOF	GREEN OFF	X	X	X	Turns OFF GREEN
	GGH	GET GH CONV DATA	X	X	X	Calls GH convergence adjusting data (For each mode)
	GGV	GET GV CONV DATA	X	X	X	Calls GV convergence adjusting data (For each mode)
	GRH	GET RH CONV DATA	X	X	X	Calls RH convergence adjusting data (For each mode)
	GRV	GET RV CONV DATA	X	X	X	Calls RV convergence adjusting data (For each mode)
	GBH	GET BH CONV DATA	X	X	X	Calls BH convergence adjusting data (For each mode)
	GBV	GET BV CONV DATA	X	X	X	Calls BV convergence adjusting data (For each mode)
	GDD	GET DEF DATA	X	X	X	Calls the main deflection adjusting data for each mode
	GWB	GET W/B DATA	X	X	X	Calls the white balance adjusting data for each mode
	GUS	GET CNV SEL DATA	X	X	X	Calls the current state of the convergence data
	GST	GET STATUS DATA	X	X	X	Calls the various setting states
	H	HPI	H PIN	X	O	O
HSI		H SIZE	X	O	O	Adjusts H deflection SIZE
HBL		H BLK-L	X	O	O	BLK width adjustment for forming conver- gence correction waveform (Left)
HBR		H BLK-R	X	O	O	BLK width adjustment for forming conver- gence correction waveform (Right)
I	IDS	ID SET	X	X	X	Sets ID
	IDC	ID CLEAR	X	X	X	Clears ID
	IN1	INPUT 1	O	X	X	Selects video input
	IN2	INPUT 2	O	X	X	Selects Y/C input
	IN3	INPUT 3	O	X	X	Selects RGB input
L	LOR	LIGHT ONLY RED	X	X	X	Displays only RED
	LOG	LIGHT ONLY GREEN	X	X	X	Displays only GREEN
	LOB	LIGHT ONLY BLUE	X	X	X	Displays only BLUE
	LWT	LINEAR WHITE	X	O	O	Adjusts LINEAR WHITE
M	MLY	MULTI YES	O	X	X	Turns ON peripheral light amount correction
	MLN	MULTI NO	O	X	X	Turns OFF peripheral light amount correction

ADJUSTMENTS

	Com- mand	Name	Normal Valid	Number Direct	UP/DW Command	Function
N	NTS	TV SYSTEM NTSC	○	×	×	Sets TV SYSTEM to NTSC (Note 4)
P	PON	POWER ON	○	×	×	Turns ON power
	POF	POWER OFF	○	×	×	Turns OFF power
	POC	POWER ON(MUTE)	○	×	×	Turns ON power with the convergence DAC muted
	PAL	TV SYSTEM PAL	○	×	×	Sets TV SYSTEM to PAL (Note 4)
R	R00	RED 00	×	○	○	RED convergence adjustment (Same as BLUE)
	R59	RED 59				
	R61	P-CONV. ADJ 61	×	○	○	RED point convergence adjustment (Same as BLUE)
	RP0	P-CONV. ADJ P0				
	RHI	RED HIGH LIGHT	×	○	○	RED HIGH-LIGHT adjustment
	RLW	RED LOW LIGHT	×	○	○	RED LOW-LIGHT adjustment
	RON	RED ON	×	×	×	Turns ON RED
	ROF	RED OFF	×	×	×	Turns OFF RED
S	SHP	SHARPNESS	×	○	○	Adjusts SHARPNESS (Note 6)
	STD	STD W/B DATA	×	×	×	Re-writes white balance adjusting data in factory memory
	STC	STD CONV DATA	×	×	×	Re-writes convergence adjusting data in factory memory
	SW1	SWITCH MENU 1	×	×	×	Displays various settings in OSD
T	TNT	TINT	×	○	○	Adjusts TINT (Note 5)
	TS1	TEST CROSS 1	×	×	×	Displays test cross (Pattern 1)
	TVA	TV SYSTEM AUTO	○	×	×	Sets TV SYSTEM mode to auto mode (Note 4)
U	UP0	UP 10	×	×	×	Increases adjusting value by 10
	UPn	UP n	×	×	×	Increases adjusting value by n
	UPF	UP FULL	×	×	×	Maximizes adjusting value
	US1	USER 1	○	×	×	Switches convergence adjusting data to user 1 (Note 4)
	US2	USER 2	○	×	×	Switches convergence adjusting data to user 2 (Note 4)
	US3	USER 3	○	×	×	Switches convergence adjusting data to user 3 (Note 4)

	Command	Name	Normal Valid	Number Direct	UP/DW Command	Function
V	VSI	V SIZE	○	×	×	Adjusts V deflection SIZE
	VL1	V LINEARITY	○	×	×	Adjusts V deflection LIN
	VST	V STATIC	○	×	×	Adjusts V deflection STATIC
	VMS	V MID SIZE	○	×	×	Adjusts V deflection MID SIZE
	VML	V MID LINEARITY	○	×	×	Adjusts V deflection MID LIN
	VMY	VIDEO MUTE ON	×	×	×	Sets video mute to ON when the input function switches
	VMN	VIDEO MUTE OFF	×	×	×	Sets video mute to OFF when the input function switches

Note 1 : The ABL command is valid only in the ABL combination ON (CBY) state.

Note 2 : The UP/DOWN commands that can be used for the point convergence adjustment are as follow.

Move up→UP1

Move down→DW1

Move to right→RI1

Move to left→LE1

Adjustment of each area use the commands as follow.

File area adjustment ——RI1 and LE1 are available.

Command name : RP□, GP□, BP□ (□ ; 2, 4, 6, 8, 0)

Line area adjustment ——UP1 and DW1 are available.

Command name : RP□, GP□, BP□ (□ ; 1, 3, 5, 7, 9)

Note 3 : The COL, CON, and COF commands are not valid during RGB input.

Note 4 : The TV SYSTEM selection command and convergence adjustment data memory area selection command can be set separately for when the input function is set to VIDEO or Y/C and when it is set to RGB.

Note 5 : The TNT commands are not valid during RGB input. Neither valid during PAL input besides RGB.

Note 6 : The SHP commands are not valid during RGB input.

<Meanings of the command table>

• Normal valid

Command which can be used only when the adjustment mode is set using a command.

○; Receive a command regardless of AJY/AJN

×; Receive a command AJY

• Number direct

Command which can directly be specified as the adjusting value when added with 000 to 255.

○; The value provided is a direct command. (Example : For CNT070, the contrast is set to 70.)

×; Not a Numeral direct command. (Example : For IN1128, only IN1 is executed.)

• UP/DW command

A command which manipulates the adjustment value for the value UPn/ DWn (n is an arbitrary number between 0 to 9 and F) provided after the command.

ADJUSTMENTS

③ LIST OF GET COMMANDS

What are GET Commands?

- Commands which output adjustment data, etc. from Multi projection unit microprocessor to the PC.
- The adjustment data is output for every mode.

Example 1)When <GGH> command is set when CONV.DATA MEMO-1 is selected, the GREEN horizontal convergence data of MEMO-1 will be get. In the same way, when <GGH> command is set when CONV.DATA MEMO 2 to 3 are selected, the GREEN horizontal convergence data of MEMO-2 to 3 will be get.

Example 2)When <GWB> command is set when COLOR MODE =1 and at the same time, INPUT=RGB, the W/B DATA for COLOR MODE=1 and INPUT=RGB will be get.

- Only valid for one ID. (Invalid for ID=**, 1*, *1, etc.)
- The adjustment data, etc. is output in ASCII codes.

Note)< > indicates the command name.

- [1] <GRH> (GET RH CONV.DATA)=RED horizontal convergence data is output.
<GGH> (GET GH CONV.DATA)=GREEN horizontal convergence data is output.
<GBH> (GET BH CONV.DATA)=BLUE horizontal convergence data is output.

Format:Output in the following order.

①STX (02H)		
②<□30>/□H STATIC	adjustment data	(3 BYTE)
③<□31>/□H SKEW	adjustment data	(3 BYTE)
④<□32>/□H BOW	adjustment data	(3 BYTE)
⑤<□36>/□H SIZE	adjustment data	(3 BYTE)
⑥<□42>/□H LINEARITY	adjustment data	(3 BYTE)
⑦<□37>/□H KEY	adjustment data	(3 BYTE)
⑧<□43>/□H SUB KEY	adjustment data	(3 BYTE)
⑨<□38>/□H PIN	adjustment data	(3 BYTE)
⑩<□44>/□H SUB PIN	adjustment data	(3 BYTE)
⑪<□33>/□H 3D SKEW	adjustment data	(3 BYTE)
⑫<□34>/□H 4D BOW	adjustment data	(3 BYTE)
⑬<□53>/□H 5D SKEW	adjustment data	(3 BYTE)
⑭<□59>/□H 6D BOW	adjustment data	(3 BYTE)
⑮<□48>/□H MID SIZE	adjustment data	(3 BYTE)
⑯<□54>/□H MID LIN	adjustment data	(3 BYTE)
⑰<□44>/□H 5D SIZE	adjustment data	(3 BYTE)
⑱<□47>/□H 6D LIN	adjustment data	(3 BYTE)
⑲<□44>/□H 3D KEY	adjustment data	(3 BYTE)
⑳<□45>/□H 3D S-KEY	adjustment data	(3 BYTE)
㉑<□40>/□H 4D PIN	adjustment data	(3 BYTE)
㉒<□46>/□H 4D S-PIN	adjustment data	(3 BYTE)
㉓<□49>/□H MID KEY	adjustment data	(3 BYTE)
㉔<□55>/□H MID S-KEY	adjustment data	(3 BYTE)
㉕<□50>/□H MID PIN	adjustment data	(3 BYTE)
㉖<□56>/□H MID S-PIN	adjustment data	(3 BYTE)
㉗<□51>/□H MID 3D KEY	adjustment data	(3 BYTE)
㉘<□57>/□H MID 3D S-KEY	adjustment data	(3 BYTE)
㉙<□52>/□H MID 4D PIN	adjustment data	(3 BYTE)
㉚<□58>/□H MID 4D S-PIN	adjustment data	(3 BYTE)
㉛ETX (03H)		

Note □:R or G or B

- [2] <GRV> (GET RV CONV.DATA)=RED horizontal convergence data is output.
 <GGV> (GET GV CONV.DATA)=GREEN horizontal convergence data is output.
 <GBV> (GET BV CONV.DATA)=BLUE horizontal convergence data is output.

Format:Output in the following order.

①STX (02H)		
②<□00>/□V STATIC	adjustment data	(3 BYTE)
③<□06>/□V SKEW	adjustment data	(3 BYTE)
④<□12>/□V BOW	adjustment data	(3 BYTE)
⑤<□01>/□V SIZE	adjustment data	(3 BYTE)
⑥<□02>/□V LINEARITY	adjustment data	(3 BYTE)
⑦<□07>/□V KEY	adjustment data	(3 BYTE)
⑧<□08>/□V SUB KEY	adjustment data	(3 BYTE)
⑨<□13>/□V PIN	adjustment data	(3 BYTE)
⑩<□14>/□V SUB PIN	adjustment data	(3 BYTE)
⑪<□18>/□V 3D SKEW	adjustment data	(3 BYTE)
⑫<□24>/□V 4D BOW	adjustment data	(3 BYTE)
⑬<□11>/□V 5D SKEW	adjustment data	(3 BYTE)
⑭<□17>/□V 6D BOW	adjustment data	(3 BYTE)
⑮<□03>/□V MID SIZE	adjustment data	(3 BYTE)
⑯<□04>/□V MID LIN	adjustment data	(3 BYTE)
⑰<□23>/□V 5D SIZE	adjustment data	(3 BYTE)
⑱<□29>/□V 6D LIN	adjustment data	(3 BYTE)
⑲<□19>/□V 3D KEY	adjustment data	(3 BYTE)
⑳<□20>/□V 3D S-KEY	adjustment data	(3 BYTE)
㉑<□25>/□V 4D PIN	adjustment data	(3 BYTE)
㉒<□26>/□V 4D S-PIN	adjustment data	(3 BYTE)
㉓<□09>/□V MID KEY	adjustment data	(3 BYTE)
㉔<□10>/□V MID S-KEY	adjustment data	(3 BYTE)
㉕<□15>/□V MID PIN	adjustment data	(3 BYTE)
㉖<□16>/□V MID S-PIN	adjustment data	(3 BYTE)
㉗<□21>/□V MID 3D KEY	adjustment data	(3 BYTE)
㉘<□22>/□V MID 3D S-KEY	adjustment data	(3 BYTE)
㉙<□27>/□V MID 4D PIN	adjustment data	(3 BYTE)
㉚<□28>/□V MID 4D S-PIN	adjustment data	(3 BYTE)
①ETX (03H)		

Note □:R or G or B

- [3] <GDD> (GET DEFLECTION DATA)-Deflection adjusting data is output.

Format:Output in the following order.

①STX (02 H)		
②<HSI>/ H SIZE	adjustment data	(3 BYTE)
③<VST>/ V STATIC	adjustment data	(3 BYTE)
④<VSI>/ V SIZE	adjustment data	(3 BYTE)
⑤<VLI>/ V LINEARITY	adjustment data	(3 BYTE)
⑥<VMS>/ V MID SIZE	adjustment data	(3 BYTE)
⑦<VML>/ H MID LINEARITY	adjustment data	(3 BYTE)
⑧<HBL>/ H BLK-L	adjustment data	(3 BYTE)
⑨<HBR>/ H BLK-R	adjustment data	(3 BYTE)
⑩<HPI>/ H PIN	adjustment data	(3 BYTE)
①ETX (03 H)		

ADJUSTMENTS

[4] <GWB> (GET W/B DATA)-White balance adjustment data is output.

Format:Output in the following order.

①STX (02H)			
②<LWT>/ LINEAR WHITE	adjustment data	(3 BYTE)	
③<CNT>/CONTRAST	adjustment data	(3 BYTE)	
④<BRT>/BRIGHTNESS	adjustment data	(3 BYTE)	
⑤<COL>/COLOR	adjustment data	(3 BYTE)	Note 1)
⑥<TNT>/TINT	adjustment data	(3 BYTE)	Note 1) and Note 3)
⑦<BLW>/BLUE LOW-LIGHT	adjustment data	(3 BYTE)	
⑧<GLW>/GREEN LOW-LIGHT	adjustment data	(3 BYTE)	
⑨<RLW>/RED LOW-LIGHT	adjustment data	(3 BYTE)	
⑩<BHI>/BLUE HIGH-LIGHT	adjustment data	(3 BYTE)	
⑪<GHI>/GREEN HIGH-LIGHT	adjustment data	(3 BYTE)	
⑫<RHI>/RED HIGH-LIGHT	adjustment data	(3 BYTE)	
⑬<SHP>/SHARPNESS	adjustment data	(3 BYTE)	Note 1) and Note 5)
⑭<ABL>/ABL LEVEL	adjustment data	(3 BYTE)	Note 2) and Note 4)
⑮<ABG>/ABL GAIN	adjustment data	(3 BYTE)	Note 2)
⑯ETX (03H)			

Note 1)Dummy when INPUT=RGB

Note 2)No dependent on mode. (Has one data.)

Note 3)Dummy when PAL signal is input. (INPUT=VIDEO or Y/C)

Note 4)Dummy when COMBINATION=OFF (Data is output when COMBINATION=ON)

Note 5)SHARPNESS data for OFF is output when MULTI=OFF, and SHARPNESS data for ON is output when MULTI=ON.

[5] <GUS> (GET CONV. USER DATA)=Deflection and convergence data memory area setting state is output.

①STX (02H)		
②Memory area selected when INPUT=VIDEO or Y/C & input signal=NTSC.		(3 BYTE)
Example)US 1:Indicates CONV.MEMO-1 is selected.		
③Memory area selected when INPUT=VIDEO or Y/C & input signal=PAL (Or other than NTSC, containing no signals).		(3 BYTE)
Example)US 2:Indicates CONV.MEMO-2 is selected.		
④Memory area selected when INPUT=RGB & input signal=NTSC.		(3 BYTE)
Example)US 1:Indicates CONV.MEMO-1 is selected.		
⑤Memory area selected when INPUT=RGB & input signal=PAL (or other than NTSC, containing no signals).		(3 BYTE)
Example)US 2:Indicates CONV.MEMO-2 is selected.		
⑥ETX (03H)		

[6] <GST> (GET STATUS)-Various setting states are output.

- ① STX (02H)
- ② Version of microcomputer software (5 BYTE)
Example)V1.00:Indicates VERSION 1.00.
- ③ Input function state (3 BYTE)-Output in command name.
Example)IN1:Indicates VIDEO input.
- ④ MULTI state (3 BYTE)-Output in command name.
Example)MLY:Indicates MULTI=ON.
- ⑤ COLOR MODE state (3 BYTE)-Output in command name.
Example)CM1:Indicates COLOR MODE=1.
- ⑥ COMBINATION state (3 BYTE)-Output in command name.
Example)CMY:Indicates COMBINATION=ON.
- ⑦ TV SYSTEM MODE state (3 BYTE)-Output in command name. (Note 1)
Example)TVA:Indicates TV SYSTEM=AUTO.
- ⑧ Indicates the input discriminating result of TV SYSTEM=AUTO (Note 2)
Example)NTS:Input discriminating result indicates NTSC.
- ⑨ Deflection and convergence data memory area state (3 BYTE) (Note 1)
US1:Indicates that CONV.MEMO-1 is selected.
US2:Indicates that CONV.MEMO-2 is selected.
US3:Indicates that CONV.MEMO-3 is selected.
- ⑩ OSD display, enable/disable setting state (3 BYTE)-Output in command name.
Example)DIY:Indicates OSD display enabled.
- ⑪ ETX (03H)

Note 1) When INPUT=VIDEO or Y/C, the VIDEO or Y/C input setting is output.
When INPUT=RGB, the RGB input setting is output.

Note 2) If it does not TV SYSTEM=AUTO, mode will output the same state of ⑦ TV SYSTEM.

ADJUSTMENTS

④ PRECAUTIONS

[1] The adjusted data is backed up by the AJN command.

After adjustments, always perform AJN. AJN will also exit the screen adjustment display.

[2] Contents of the INPUT FUNCTION, MULTI ON/OFF, COMBINATION ON/OFF, COLOR MODE 1/2, TV SYSTEM, CONV.MEMORY are memorized only when the power is turned OFF using the remote control, POF command, or the TACT switch on the rear panel, and finish the adjustment mode (if you were set each data in the adjustment mode).
(They will not be memorized by AC ON/OFF.)

When starting up/stopping the system by AC ON/OFF under the long term installation conditions, memorize the contents before executing AC ON/OFF.

[3] There is a limit to the RS-232C communication buffer in the unit. If too many commands are sent at once, it will not operate properly.

[4] The RS-232C command execution time.

When sending RS-232C command, send the next command after minimum 500m sec.

Especially, the following commands need more than 500msec.

- | | |
|---|--------|
| a) The assigned command of the POINT CONVERGENCE ADJUST POINT | 1.5sec |
| b) IN1~3 (Input switching) | 1sec |
| c) TVA,NTS,PAL (TV system setting) | 1sec |

If the next commands are sent before these time, they may not be received. Care when making programs like the direction.

[5] Exiting the personal computer adjustment mode

The personal computer adjustment mode is automatically exited when the following steps are performed.

- When the rear panel switch is set.
- When the power is turned OFF.
- When the input signal is switched, the cable is disconnected, or the mode is switched: NTSC ⇔ PAL.
(However, in some cases, switching between PAL and no-signal may not exit the mode.)

To continue adjustments, set the re-adjustment mode again.

(7) Adjustments by Remote Control

Multi projection unit adjustments can be performed using the remote control (RU-V107) besides the computer and software.

All adjustments are performed only using the remote control.

Up to 16 units can be operated using the remote control unit at one time using the link cable.

① Remote control functions.

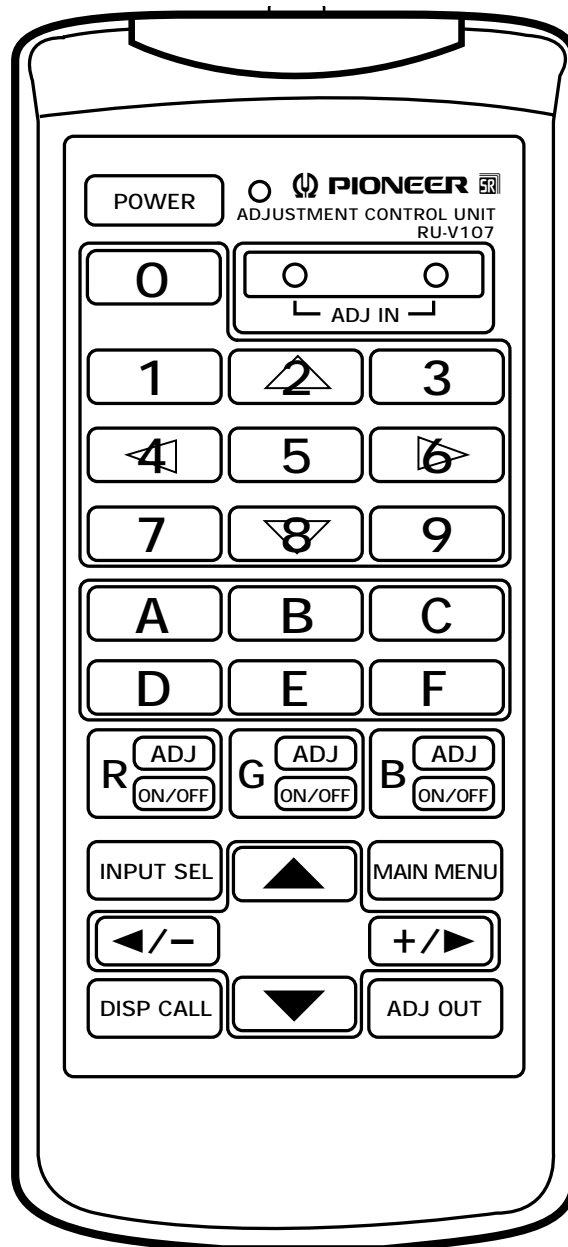

ADJUSTMENTS

1) 

- Turns on/off the power of the unit.

2) 

<Adjustment Mode>

- Selects ID CLEAR in the ID SET/CLEAR/SELECT MODE. Also selects "0" for ID SET and ID SELECT.
- Selects V STATIC in the DEFLECTION ADJUST MODE.
- Selects ABL GAIN in the WHITE BALANCE ADJUST MODE.
- Cyclically selects the adjustment items in the POINT CONVER ADJUST MODE in the following order.

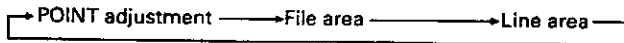

3, 4) 

- Starts up the adjustment mode when the two buttons are pressed simultaneously.

5) 

<Adjustment Mode>

- Selects 1 (ID SET/SELECT/CLEAR MODE) of the main menu of the adjustment mode.
- Sets ID SET in the ID SET/CLEAR/SELECT MODE. Also selects "1" for ID SET and ID SELECT.
- Selects STATIC in the CONVERGENCE ADJUST MODE.
- Selects CONTRAST in the WHITE BALANCE ADJUST MODE.
- Returns the CONVERGENCE ADJUST DATA to the factory set data in the MEMORY READ/COPY MODE.
- Select the pattern (1→2) for copying the convergence data between memories in the MEMORY READ/COPY MODE.

6) 

<Adjustment Mode>

- Selects 2 (OPERATION MODE) of the main menu of the adjustment mode.
- Sets ID SELECT in the ID SET/CLEAR/SELECT MODE. Also selects "2" for ID SET and ID SELECT.
- Cyclically selects the input function in the OPERATION MODE in the following order.

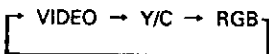

- Selects the V SIZE in the DEFLECTION ADJUST MODE.
- Cyclically selects the item to be adjusted in the CONVERGENCE ADJUST MODE in the following order.

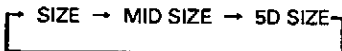

- Moves the point to be adjusted up in the POINT CONVER ADJUST MODE.
- Selects BRIGHTNESS in the WHITE BALANCE ADJUST MODE.
- Returns the WHITE BALANCE ADJUST DATA to the factory set data in the MEMORY READ/COPY MODE.
- Select the pattern (1→3) for copying the convergence data between memories in the MEMORY READ/COPY MODE.

7) 

<Adjustment Mode>

- Selects 3 (DEFLECTION ADJUST MODE) of the main menu of the adjustment mode.
- Selects "3" for ID SET and ID SELECT in the ID SET/CLEAR/SELECT MODE.
- Cyclically switches MULTI ON/OFF in the OPERATION MODE.
- Selects V MID SIZE in the DEFLECTION ADJUST MODE.
- Cyclically selects the item to be adjusted in the CONVERGENCE ADJUST MODE in the following order.



- Selects COLOR in the WHITE BALANCE ADJUST MODE(only invalid for RGB input).
- Reset the various setting value in the MEMORY READ/COPY MODE.
- Select the pattern (2→1) for copying the convergence data between memories in the MEMORY READ/COPY MODE.

8) **4**

<Adjustment Mode>

- Selects 4 (CONVERGENCE ADJUST MODE) of the main menu of the adjustment mode.
- Selects "4" for ID SET and ID SELECT in the ID SET/CLEAR/SELECT MODE.
- Cyclically switches COLOR MODE 1/2 in the OPERATION MODE.
- Cyclically selects the item to be adjusted in the CONVERGENCE ADJUST MODE in the following order.

→ SKEW → 3D SKEW → 5D SKEW

- Moves the point to be adjusted to the left in the POINT CONVER ADJUST MODE.
- Selects TINT in the WHITE BALANCE ADJUST MODE(only invalid for RGB and PAL signal input).
- Select the pattern (2→3) for copying the convergence data between memories in the MEMORY READ/COPY MODE.

9) **5**

<Adjustment Mode>

- Selects 5 (POINT CONVERGENCE ADJUST MODE) of the main menu of the adjustment mode.
- Selects "5" for ID SET and ID SELECT in the ID SET/CLEAR/SELECT MODE.
- Cyclically switches COMBINATION ON/OFF in the OPERATION MODE.
- Selects H SIZE in the DEFLECTION ADJUST MODE.
- Cyclically selects the item to be adjusted in the CONVERGENCE ADJUST MODE in the following order.

→ KEY → MID KEY → 3D KEY → MID 3D KEY

- Selects SHARPNESS in the WHITE BALANCE ADJUST MODE(only invalid for RGB input).
- Select the pattern (3→1) for copying the convergence data between memories in the MEMORY READ/COPY MODE.

10) **6**

<Adjustment Mode>

- Selects 6 (WHITE BALANCE ADJUST MODE) of the main menu of the adjustment mode.
- Selects "6" for ID SET and ID SELECT in the ID SET/CLEAR/SELECT MODE.
- Cyclically switches VIDEO MUTE ON/OFF in the OPERATION MODE.
- Selects V LINEARITY in the DEFLECTION ADJUST MODE.
- Cyclically selects the item to be adjusted in the CONVERGENCE ADJUST MODE in the following order.

→ SUB KEY → MID SUB KEY → 3D SUB KEY → MID 3D SUB KEY

- Moves the point to be adjusted to the right in the POINT CONVER ADJUST MODE.
- Selects LINEAR WHITE in the WHITE BALANCE ADJUST MODE.
- Select the pattern (3→2) for copying the convergence data between memories in the MEMORY READ/COPY MODE.

11) **7**

<Adjustment Mode>

- Selects 7 (MEMORY READ MODE) of the main menu of the adjustment mode.
- Selects "7" for ID SET and ID SELECT in the ID SET/CLEAR/SELECT MODE.
- Cyclically selects the RS-232C baud rate in the OPERATION MODE in the following order.

→ 1200 → 2400 → 4800 → 9600 → 19200

- Selects H BLK-L in the DEFLECTION ADJUST MODE.
- Cyclically selects the item to be adjusted in the CONVERGENCE ADJUST MODE in the following order.

→ BOW → 4D BOW → 6D BOW

- Selects RED HIGHLIGHT in the WHITE BALANCE ADJUST MODE.

ADJUSTMENTS

12) **8**

<Adjustment Mode>

- Selects "8" for ID SET and ID SELECT in the ID SET/CLEAR/SELECT MODE.
- Cyclically selects TV SYSTEM in the OPERATION MODE in the following order.

→ AUTO → NTSC → PAL →

- Cyclically selects the item to be adjusted in the CONVERGENCE ADJUST MODE in the following order.

→ PIN → MID PIN → 4D PIN → MID 4D PIN →

- Moves the point to be adjusted down in the POINT CONVER ADJUST MODE.
- Selects GREEN HIGH-LIGHT in the WHITE BALANCE ADJUST MODE.
- Selects H BLK-R in the DEFLECTION ADJUST MODE.

13) **9**

<Adjustment Mode>

- Selects "9" for ID SET and ID SELECT in the ID SET/CLEAR/SELECT MODE.
- Cyclically selects TV SYSTEM in the OPERATION MODE in the following order.

→ 1 → 2 → 3 →

- Selects V MID LINEARITY in the DEFLECTION ADJUST MODE.
- Cyclically selects the item to be adjusted in the CONVERGENCE ADJUST MODE in the following order.

→ SUB PIN → MID SUB PIN → 4D SUB PIN → MID 4D SUB PIN →

- Selects BLUE HIGH-LIGHT in the WHITE BALANCE ADJUST MODE.

14) **A**

<Adjustment Mode>

- Selects "A" for ID SET and ID SELECT in the ID SET/CLEAR/SELECT MODE.
- Subtracts 10 from the current CONTRAST adjusting value in the DEFLECTION ADJUST MODE, CONVERGENCE ADJUST MODE, and POINT CONVER ADJUST MODE. (Returns to the original adjusting value when the adjustment mode is exited.)
- Selects RED LOW-LIGHT in the WHITE BALANCE ADJUST MODE.

15) **B**

<Adjustment Mode>

- Selects "B" for ID SET and ID SELECT in the ID SET/CLEAR/SELECT MODE.
- Selects H PIN in the DEFLECTION ADJUST MODE.
- Selects GREEN LOW-LIGHT in the WHITE BALANCE ADJUST MODE.

16) **C**

<Adjustment Mode>

- Selects "C" for ID SET and ID SELECT in the ID SET/CLEAR/SELECT MODE.
- Adds 10 to the current CONTRAST adjusting value in the DEFLECTION ADJUST MODE, CONVERGENCE ADJUST MODE, and POINT CONVER ADJUST MODE. (Returns to the original adjusting value when the adjustment mode is exited.)
- Selects BLUE LOW-LIGHT in the WHITE BALANCE ADJUST MODE.

17) **D**

<Adjustment Mode>

- Selects "D" for ID SET and ID SELECT in the ID SET/CLEAR/SELECT MODE.
- Selects GH LINEARITY in the DEFLECTION ADJUST MODE.
(Note: This adjustment item is the same as GH LINEARITY in the convergence ADJUST MODE.)
- Selects ABL LEVEL in the WHITE BALANCE ADJUST MODE. (It is validity at COMBINATION=ON.)

18) 

<Adjustment Mode>

- Selects "E" for ID SET and ID SELECT in the ID SET/CLEAR/SELECT MODE.

19) 

<Adjustment Mode>

- Selects "F" for ID SET and ID SELECT in the ID SET/CLEAR/SELECT MODE.

20) 

<Adjustment Mode>

- Cyclically switches the adjusting color and direction between RH and RV in the CONVERGENCE ADJUST MODE.
- Selects the adjusting color RED in the POINT CONVER ADJUST MODE.

21) 

<Adjustment Mode>

- Cyclically switches the adjusting color and direction between GH and GV in the CONVERGENCE ADJUST MODE.
- Selects the adjusting color GREEN in the POINT CONVER ADJUST MODE.

22) 

<Adjustment Mode>

- Cyclically switches the adjusting color and direction between BH and BV in the CONVERGENCE ADJUST MODE.
- Selects the adjusting color BLUE in the POINT CONVER ADJUST MODE.

23) 

<Adjustment Mode>

- Cyclically switches RED ON/OFF in the DEFLECTION ADJUST MODE, CONVERGENCE ADJUST MODE, and POINT CONVER ADJUST MODE.

<Normal Mode>

- Sets the input function to VIDEO.

24) 

<Adjustment Mode>

- Cyclically switches GREEN ON/OFF in the DEFLECTION ADJUST MODE, CONVERGENCE ADJUST MODE, and POINT CONVER ADJUST MODE.

<Normal Mode>

- Sets the input function to Y/C.

25) 

<Adjustment Mode>

- Cyclically switches BLUE ON/OFF in the DEFLECTION ADJUST MODE, CONVERGENCE ADJUST MODE, and POINT CONVER ADJUST MODE.

<Normal Mode>

- Sets the input function to RGB.

ADJUSTMENTS

26) 

<Normal Mode>

- Cyclically switches the input function in the following order.

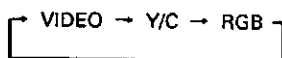

27) 

<Adjustment Mode>

- Moves the convergence up in the POINT CONVER ADJUST MODE.

28) 

<Adjustment Mode>

- Returns the main menu of the adjustment mode.

29) 

<Adjustment Mode>

- Decreases the adjusting value.
- Moves the convergence to the left in the POINT CONVER ADJUST MODE.

30) 

<Adjustment Mode>

- Increases the adjusting value.
- Moves the convergence to the right in the POINT CONVER ADJUST MODE.

31) 

<Adjustment Mode>

- Turns on the test cross mark in the DEFLECTION ADJUST MODE, and CONVERGENCE ADJUST MODE.

<Normal Mode>

- Cyclically switches the status display in the ON/OFF.

32) 

<Adjustment Mode>

- Moves the convergence down in the POINT CONVER ADJUST MODE.

33) 

<Adjustment Mode>

- Exits the adjustment mode.

34) LED for Confirming Transmission

② Performing Adjustments

1) Entering and exiting the adjustment mode

Turn on the power switch and press the two  keys of the remote control together. The adjustment mode will be set.

To exit this mode, press the  key of the remote control. The normal screen will return.

2) Using the adjustment mode

The following main menu will be displayed when the adjustment mode is entered.

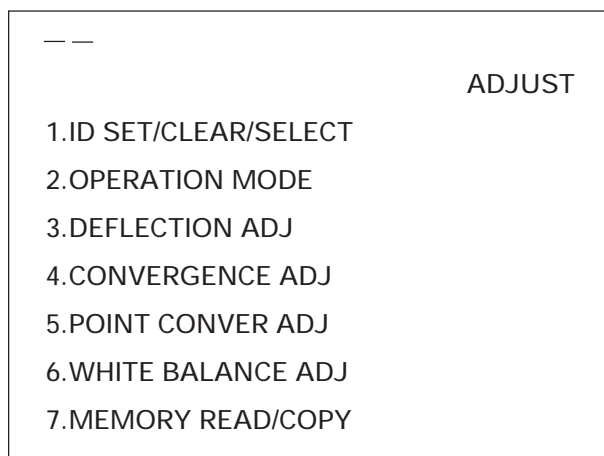

• Main Menu

1) ID SET/CLEAR/SELECT mode

Used for selecting, setting and clearing the ID.

2) OPERATION mode

Switches the setting such as input selection, ABL linkage ON/OFF, etc.

3) DEFLECTION ADJ mode

Adjusts the main deflection size, etc. (But all three colors RGB at once except GH LINEARITY.)

4) CONVERGENCE ADJ mode

Adjusts the convergence. (R, G, and B can be adjusted individually.)

5) POINT CONVER ADJ mode

Adjusts the convergence by point and zone convergence. (R,G,and B can be adjusted individually.)

6) WHITE BALANCE ADJ mode

Adjusts the white balance, color.

7) MEMORY READ/COPY mode

Adjusts the current value (both convergence and white balance) to the value set at shipment, and copy the convergence data between the memories.



ADJUSTMENTS

③ Adjustment Examples

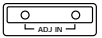
[1] Setting the ID

- 1) Enter the adjustment mode by  key.
- 2) The main menu will be displayed. Press the **1** key to select [1. ID SET/CLEAR/SELECT].
- 3) Check that the ID display at the top left of the screen is [- -]. Press the **1** key to select [1. ID SET].
When an ID has already been provided, delete the ID as follows and perform from step 1).
 - a) Press the  key to set the adjustment mode. The main menu will be displayed.
 - b) Press the **1** key and select [1. ID SET/CLEAR/SELECT].
 - c) Press the **0** key to delete the ID.
- 4) The ID input standby state will be set. Use the **0** to **9** and **A** to **F** keys to input the ID.
- 5) If several units are used, return to step 1) and set the ID of the next unit.

[2] Entering the adjustment mode of certain units only.

- 1) Enter the adjustment mode.
- 2) Check that all the screens display the adjustment mode. Press the **1** key to select [1. ID SET/CLEAR/SELECT] of the main menu.
- 3) Another menu will be displayed. Press the  key to select [2. ID SELECT].
- 4) Input the ID of the unit to be adjusted.
- 5) Only the unit corresponding to the ID input will display the main menu. All other units will be in the standby state.
- 6) Perform the usual adjustments.
- 7) ㉑ To continue adjusting the screen for which ID has been selected
Press the  key to return to the main menu.
- ㉒ Ending the adjustment mode
Press the  key and return to the NORMAL OPERATION MODE. (Note)
- ㉓ Adjusting another unit
Repeat the mentioned operation 1) to 7).

Note) Even if a certain unit has timed-out and is shifting to the normal mode, be sure to perform one of the following steps a) or b) or c). If not, the unit for which ID SELECT has not been performed will remain in the standby state.

Example) When the ID=21 screen in the right figure is selected and left for more than 180 seconds without performing any operation:

Bottom left screen : Normal mode

Other screens : Standby state of the remote control adjustment mode.

To exit from these states, perform the following.

ID=21	

a) To continue adjustment

Press the  key to set all screens into the remote control adjustment mode, and perform adjustments.

b) To end adjustments

Press the  key and exit from the remote control adjustment mode of screens in the standby state.

c) To turn OFF the power

Press the  key to turn OFF the power of all screens (STANDBY state).

[3] Adjusting the H SIZE

- 1) Enter the adjustment mode.
- 2) Press the **3** key to select [3. DEFLECTION ADJ].
- 3) Press the **5** key to select [H SIZE]. Then use the **←/→** and **+/-** keys to adjust the H PHASE.

The following can be adjusted using similar methods.

- | | |
|---------------------------|---|
| 0 key: V STATIC | 7 key: H BLK-L |
| 1 key: V SIZE | 8 key: H BLK-R |
| 3 key: V MID SIZE | 9 key: V MID LINEARITY |
| 5 key: H SIZE | B key: H PIN |
| B key: V LINEARITY | D key: GH LINEARITY (is the same as GH LINEARITY in "4. CONVERGENCE ADJ".) |

[4] Adjusting the green horizontal size (GH SIZE)

- 1) Enter the adjustment mode.
- 2) Press the **4** key to select [4. CONVERGENCE ADJ].
- 3) Press the **G ADJ** key until the OSD display becomes [GH].

The following can be adjusted in the same way.

R ADJ key : RH ↔ RV

B ADJ key : BH ↔ BV

- 4) Press the **1** key until the OSD display becomes [SIZE].

Then use the **←/→** and **+/-** keys to adjust the GH SIZE.

The following can be adjusted in the same way.

- | | |
|----------------|---|
| 1 key : | STATIC |
| 1 key : | SIZE → MID SIZE → 5D SIZE |
| 3 key : | LINEARITY → MID LINEARITY → 6D LINEARITY |
| 4 key : | SKEW → 3D SKEW → 5D SKEW |
| 5 key : | KEY → MID KEY → 3D KEY → MID 3D KEY |
| B key : | SUB KEY → MID SUB KEY → 3D SUB KEY → MID 3D SUB KEY |
| 7 key : | BOW → 4D BOW → 6D BOW |
| 8 key : | PIN → MID PIN → 4D PIN → MID 4D PIN |
| 9 key : | SUB PIN → MID SUB PIN → 4D SUB PIN → MID 4D SUB PIN |

ADJUSTMENTS

[5] Adjusting the red point convergence

- 1) Enter the adjustment mode.
- 2) Press the **5** key to select [5. POINT CONVER ADJ].
- 3) Press the **R ADJ** key so that only the blue of the screen is erased.
The following can be selected in the same way.

G ADJ : Green adjustment
B ADJ : Blue adjustment.

- 4) Use the **▲**, **◀**, **▶** and **⌂** keys to move the OSD display to the point to be adjusted on the screen, and use the **▲**, **▼**, **◀/→** and **+ /▶** keys to adjust the convergence of that point.
- 5) Pressing the **0** key will select the area adjustment and point adjustment cyclically.

[6] Adjusting the red high light

- 1) Set the adjustment mode.
- 2) Press the **B** key to select [6. WHITE BALANCE ADJ].
- 3) Press the **7** key to select [R HIGH]. And use the **◀/→** and **+ /▶** keys to adjust the red high light.
The following can be adjusted in the same way.

0 key : ABL GAIN	7 key : R HIGH
1 key : CONTRAST	⌂ key : G HIGH
▲ key : BRIGHT	9 key : B HIGH
3 key : COLOR (Note 1)	A key : R LOW
◀ key : TINT (Note 2)	B key : G LOW
5 key : SHARPNESS (Note 1)	C key : B LOW
▶ key : LINEAR WHITE	D key : ABL LEVEL (Note 3)

(Note 1) It is invalid for RGB input.

(Note 2) It is invalid for RGB and PAL input.

(Note 3) It is valid only at COMBINATION =ON.



[7] Turning on the peripheral light amount correction (MULTI)

- 1) Enter the adjustment mode.
- 2) Press the **▲** key to select [2. OPERATION MODE].
- 3) Press the **3** key to turn on/off the peripheral light amount correction (MULTI).







The following can be performed in the same way.

▲ key : Input selection (**VIDEO** → **Y/C** → **RGB**)
3 key : Peripheral light amount correction (ON ↔ OFF)
◀ key : Color mode (1 ↔ 2)
5 key : COMBINATION (ON ↔ OFF)
▶ key : VIDEO MUTE (ON ↔ OFF)
7 key : Baud rate selection (**1200BPS** → **2400BPS** → **4800BPS** → **9600BPS** → **19200BPS**)
⌂ key : TV system selection (**AUTO** → **NTSC** → **PAL**)
9 key : Convergence memory selection area switching



[8] To return the convergence and white balance adjustment data to that at shipment:

- 1) Set the adjustment mode.
- 2) Press the  key.
Select [7. MEMORY READ/COPY].
- 3) Select the number from the SUB MENU.
 key : The convergence and deflection adjustment data will return to that at shipment.
 key : The white balance adjustment data will return to that at shipment.

[9] To copy the convergence adjustment data between memories:

- 1) Set the adjustment mode.
- 2) Press the  key.
Select [7. MEMORY READ/COPY].
- 3) Press the  key of the SUB MENU.
Select [4. CONV. MEMORY COPY].
- 4) Select the copy pattern (keys  to .
- 5) If the copy pattern number is correct, press the  key within 5 seconds. (If not, the copy pattern will be displayed again.)
If the copy pattern number is wrong, press the  key and repeat from step 2 again.

[10] Resetting the setting







- 1) Set the adjustment mode.
- 2) Press the  key.
Select [7. MEMORY READ/COPY].
- 3) Press the  key of the SUB MENU.

As a result, the following settings will be set.

- MULTI (Peripheral light amount correction)=ON
- TV SYSTEM=AUTO
- Convergence memory
NTSC input (VIDEO, Y/C, RGB)=MEMO-1
PAL input (VIDEO, Y/C, RGB)=MEMO-2
Baud rate=4800 bps
- Baud rate=4800 bps
- VIDEO MUTE=OFF
- COLOR MODE=1
- COMBINATION=OFF

The adjustments using the above settings can be performed very easily.





Example : When the baud rate of each projection unit is set to 2400 bps as they are not same.

- ① Press the  key. (To set the adjustment mode).
- ② Press the  key (To select [7. MEMORY READ/COPY].)
- ③ Press the  key (As the SUB MENU is selected, 4800 bps will be selected automatically.)
• To set the baud rate to 4800 bps, proceed onto step 7.
- ④ Press the  key. (Returns to the main menu).
- ⑤ Press the  key (Select [2. OPERATION MODE]).
- ⑥ Press the  key (As the baud rate changes cyclically, 2400 bps is selected.)
- ⑦ Press the  key to select a baud rate.

The adjustment is completed.

ADJUSTMENTS

④ Precautions Upon Use (Adjustment Control Unit)

- Always release the adjustment mode with  button and turn off the power with the  button after adjustments and settings. All adjusted values and settings will be memorized.
- The remote control adjustment mode will automatically be exited in the following.
 1. When no operations are performed for about 180 seconds.
 2. When the rear panel switch is pressed
 3. When the power is turned off
 4. When the input signal is switched, the cable is disconnected, or the mode is switched : NTSC \longleftrightarrow PAL.
(However, in some cases, switching between PAL and no-signal may not exit the mode.)
- One multi-projection unit cannot be adjusted using the remote control unit and personal computer simultaneously. If using the remote control unit after the personal computer adjustment mode has been started up, start up the remote control unit adjustment mode or turn off the power once.
- When operating several multi-projection units simultaneously, do not press the buttons quickly and continuously as some units may not synchronize with the other units.
- Multi-projection units not assigned an ID cannot be operated using the remote control unit. To exit this state, perform one of the following.
 1. Start up the remote control adjustment mode using the  button.
 2. Exit the remote control adjustment mode using the  button.
 3. Turn off the power.
- The remote control signal is output to the next unit via the link terminal only when a certain ID is set to the multi projection units. When operating several units, set this ID to all the units. Only units connected with the link cable located after the units to which the remote control unit is connected can be operated.
- Up to 16 units can be operated using the remote control at one time using the link cable. To operate more than 16 units, use a personal computer as well or reconnect the remote control.
- Handle the wire carefully.

Warning for Use of Dry Batteries

- Using dry batteries incorrectly will result in battery liquid leakage, damage, etc. Take note of the following. (Also refer to precautions provided for dry batteries.)
 - Load the \oplus and \ominus sides of the batteries correctly as shown on the battery case.
 - Do not use old and new batteries together.
 - Batteries of the same shape may have different voltages.
Do not use different batteries together.
 - When not using the unit for a long period of time (one month), remove the batteries to prevent battery liquid leakage. If leakage occurs, wipe the liquid thoroughly and load new batteries.
 - Do not charge, short-circuit, disassemble, nor throw into fire the dry batteries provided.

CHAPTER 5. OPERATIONS · MAINTENANCE

1. MAINTENANCE

(1) Re-adjustments After 3 months

Although the RM-V2400N/V2500N is adequately adjusted at the time of installation, values slowly change as time goes by. When adjusted completely again, the values will more or less be stable. The time to perform the re-adjustments is about 3 months later. It is recommended that these adjustments be included in plans made when the unit arrives.

(2) Periodic Maintenance

For the unit to display its best performance stably for a long period of time, it is recommended that periodic maintenance be performed. There are mainly two types of periodic maintenance.

- Cleaning

Although this depends considerably on the environment used in, the CRT lens surface, screens, etc. are cleaned mainly.

- Re-adjustments

Re-adjustments must be performed if required.

Pioneer recommends that contracts on periodic maintenance be signed.

(3) Replacement of Parts

The replacement and addition of RM-V2400N/V2500N parts are as follows and must all be performed by Pioneer servicemen. Request for these services when required.

① CRT

The luminance of the RM-V2400N/V2500N decreases with the time used like other video equipment. How much it decreases depends on the images displayed and the using conditions. As an approximate, the decrease is about half for 10000 hours. Although this 10000 hours (four years with eight hours of use every day) is a rough approximate for replacing the CRT, decide according to the state of the unit.

② Screen

If a screen needs to be replaced due to scratches, etc., purchase a service parts screen.

■ Replacing the Screen (1)

(RMS-V4011/V5011)

The following describes the method for replacing the screen with the center unit of a 9-screen system as the example.

[1] To remove the unit to be replaced (diagonally shaded part in Fig. 5-1), remove the screen units that need to be removed. (Remove a, b, c units in this case.)

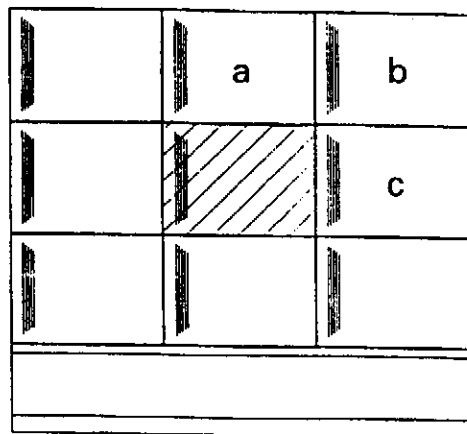

(Fig. 5-1)

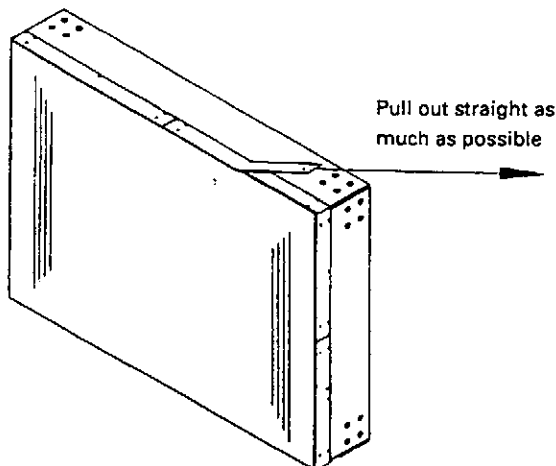

(Fig. 5-2)

OPERATIONS

- [2] Remove the panels at the top and right side of the screen unit to be replaced. (Remove 12 screws.)

The panels are made of polycarbonate. Adhesive double coated tapes are pasted to the frames. When removing the panels, do not pull the panels in directions which are difficult to pull, but pull straight as much as possible as shown in fig. 5-2 The panel will not deform in this way.

- [3] Peel off the black vinyl tape at the edges. The top and right sides of the screen will become free. Remove the screen by pulling in the top right direction. (fig. 5-3)

* The left side and bottom of the screen is fixed to the panel by adhesive double coated tape. The lenticular sheet can be removed relatively easily. The fresnel lens is fixed firmly and will not come off by just pulling in the top right direction. To remove, while pulling in the top right direction, remove it by opening it as if opening a door. (Fig. 5-4)

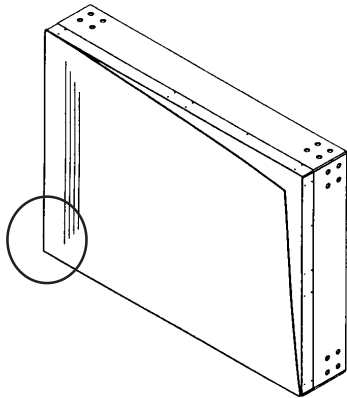

(Fig. 5-3)

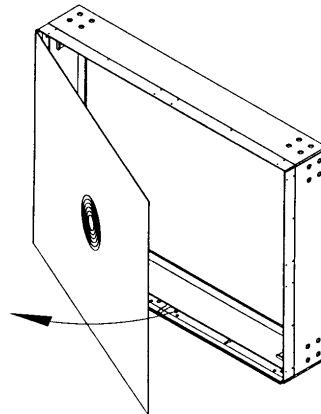

(Fig. 5-4)

- [4] Re-paste the adhesive double coated tape on the panel. It can be peeled off easily by scratching it with your finger backwards. Then paste a new adhesive double coated tape according to the figure.

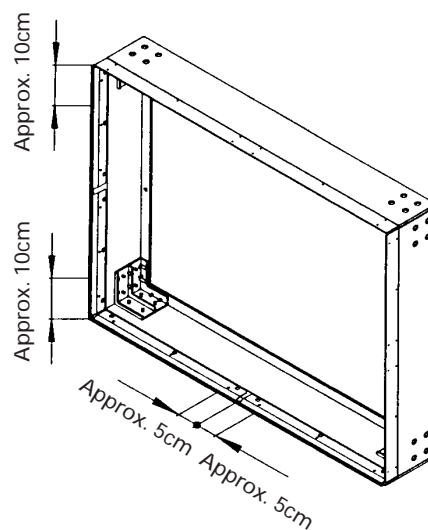

(Fig. 5-5)

- [5] Attach a new screen. While paying attention to the front and back, attach the fresnel lens.
(Flat side: The shiny side is for the projection unit side.)
- [6] In the same way, attach the lenticular sheet while paying attention to the front and back.
(The shiny side is for the fresnel lens side.)
- * When attaching the screen, past the adhesive double coated tape properly by rubbing the tape with your finger with force.
- [7] Paste a black vinyl tape around the edge of the screen. It can be pasted easily by placing the screen frame on its side. As shown in Fig. 5-6, paste the vinyl tape slightly protruding out on the edges of each screen and cut off the protruding parts. Be careful not to scratch the lenticular sheet at this time.
- [8] After peeling off all the adhesive double coated tape remaining on the back of the panel or the frame, paste the above adhesive double coated tape to the frame side. Make sure not to paste over the black vinyl tape.
- [9] Peel off the released paper of the adhesive double coated tape and paste the panel along the tapped holes. Tighten the 12 screws.
- [10] Finally, check that the screen will not come off from its front and back.

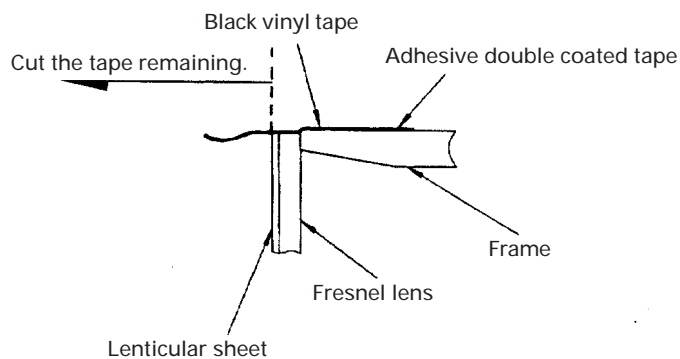

(Fig. 5-6)

■ Replacing the Screen (2)

(For RMF-V4011R, RMF-V4011CR)

(The figure shows the RMF-V4011R. Its screen joint is of the same structure as RMF-V4011CR.)

[1] Preparations

As the screen of this unit is pasted with black tape all around, peel it off before assembling it with the system.

Note

- When peeling off the black tape, peel gently and carefully so as not to damage the lenticular sheet.

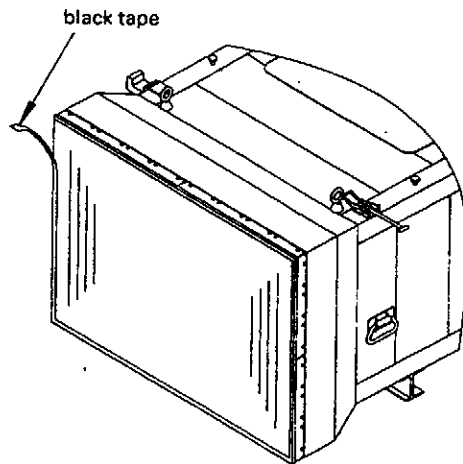

(Fig. 5-7)

[2] Replacing the screen

The screen of this unit can be replaced separately from the front even when the unit is assembled as a multi-screen.

1. Remove the removable panels according to the numbers shown in the figure. The panels at the top right of the screen can be removed by pulling them straight out, the horizontal panels can be removed by moving them to the right and pulling them out, and the vertical panels can be removed by moving them upwards and pulling them out.

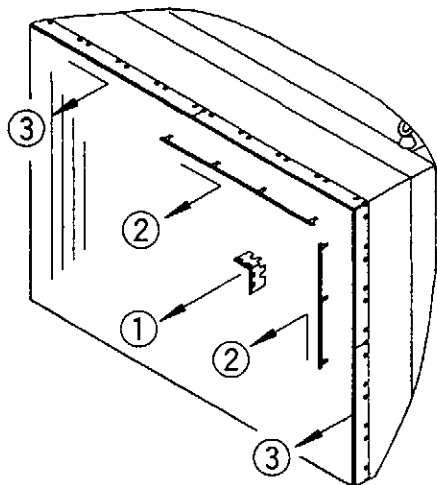

(Fig. 5-8)

2. When all panels have been removed, the top and right side of the screen will become free. Remove the screen by pulling it out from the top right. (Fig. 5-9.)

Note:

The panel is fixed by adhesive double coated tape at the left side and bottom of the screen, but the lenticular sheet can be removed relatively easily. As the Fresnel lens is secured firmly, it cannot be removed easily just by pulling out upwards to the right. To remove the Fresnel lens, pull it slowly upwards towards the right, and remove it as if opening it like a door. (Fig. 5-10)

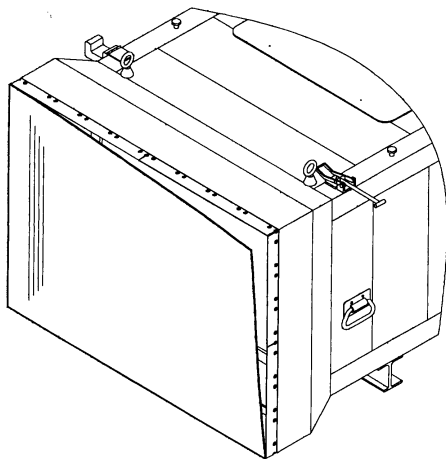

(Fig. 5-9)

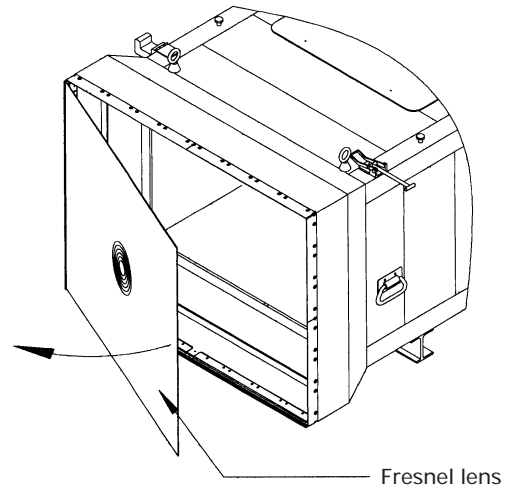

(Fig. 5-10)

3. Peel off the adhesive double coated tape remaining on the fixed panels. This can be done easily by rolling the tape into a ball with your finger. Then, paste with new adhesive double coated tape as shown in the figure. Use adhesive double coated tape approximately 5 mm wide.

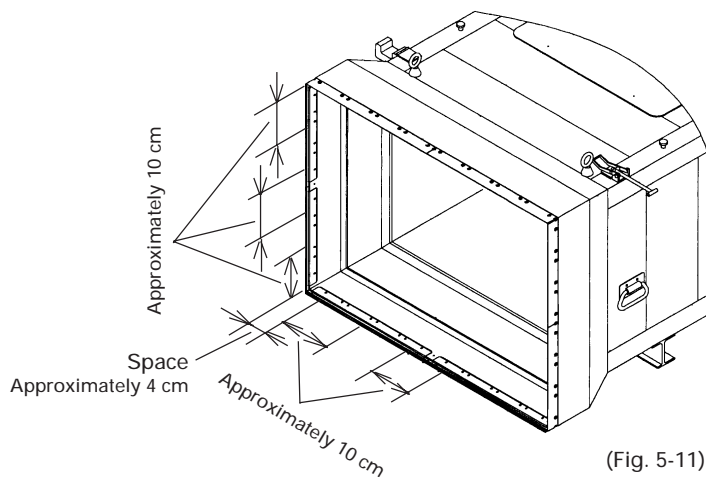

(Fig. 5-11)

4. Mount the new screen. Mount the Fresnel lens while making sure not to mistake the front and back. (That which has a shiny surface is the projection unit side.)
5. In the same way, attach the lenticular sheet while paying attention to the front and back. (The shiny side is the Fresnel lens side.)

Notes

- *When attaching the screens, rub over the adhesive double coated tape with your finger firmly from the outside to adhere the tape firmly onto the screen.*
- *Pay careful attention to the front and back of the screen. If mounted at the sides reversed, unnatural images will be produced.*

6. Attach the panels removed at step 1 in the reverse order as when they were removed.

Note

Insert each panel firmly so that they fit the stoppers.

OPERATIONS

[3] Adjusting the screen angle finely

The angle of the screen can be adjusted finely (top, bottom, left and right) by inserting and removing cabinet spacers. Add or remove spacers as desired.

Cabinet spacers are inserted between the screen and cabinet (two at the top, and two at the right). (Fig. 5.12)

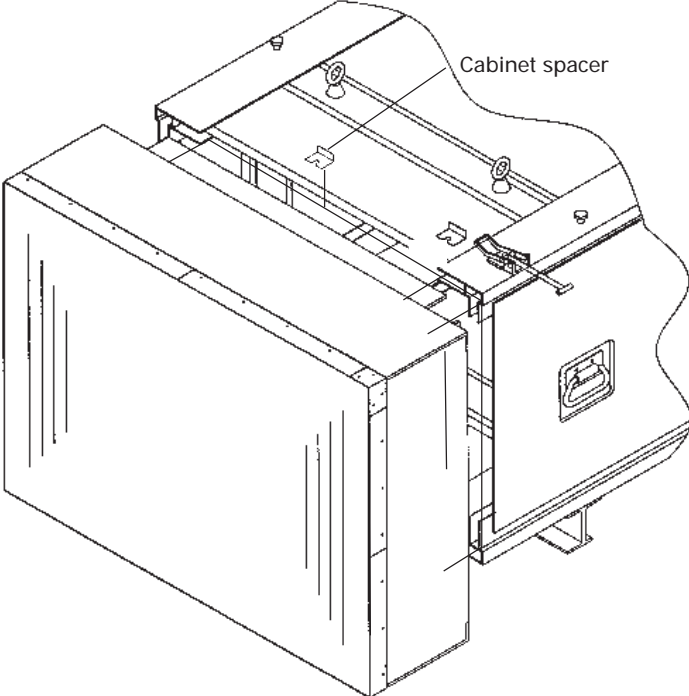

(Fig. 5.12)

■ Cleaning the screen

As dust adheres to the surface of the screen easily, it should be cleaned periodically. Use the following cleaning items for cleaning.

Name	No.
Cleaning cloth : Minimax	GED-009
Cleaning solution : B4	GEM1004 (This can be used for the CRT as well.)

As hand prints and finger prints stick easily to the screen, do not touch the screen with your bare hands, and put on gloves when working.

1. Slight dirt can be removed easily by blowing on the screen and wiping off with a soft cloth such as the specified cloth or gauze.

As the screen surface scratches easily, do not rub it with hard items nor dust with dusters.

2. If the lenticular sheet is very dirty, moisten the above specified cloth with the specified cleaning solution and wipe it.

Note: As the black print on the surface of the lenticular sheet may peel off, never use alcohol, benzine, thinner, etc.

Note: The back of the fresnel lens (flat side) is sprayed with antistatic agent. Dust will not therefore stick to it easily. Dusts can be cleaned off easily by wiping with the above specified cloth (dry). Do not use any kind of cleaning solution or the antistatic agent will lose its effects.

Also clean off difficult-to-clean oil with a dry cloth. If cleaning solution must be used, bear in mind that the above antistatic effects will be lost. However, if these effects are lost only partially, the image quality will not be affected.

Note: It is recommended that antistatic agent be applied to the surface of the lenticular sheet. Use the following product.

Antistatic agent: Nondust GYD1004

When spraying the antistatic agent, spray from as far as possible with the appropriate amount. If sprayed excessively, the spray will accumulate in the grooves on the lenticular sheet, and as a result, affect the images.

OPERATIONS

Notes

- *To produce fine joint, the left side and bottom of the screen are secure with adhesive double coated tape. Make sure the replaced screen is attached closely to the left and bottom sides of the panel. If not attached closely, the screen will disconnect from the panels when it expands and contracts according to temperature and humidity changes, or in the worst case, drop off.*
- *In replacements, make sure not to leave dust and dirt between the lenticular sheet and fresnel lens.*
- *Take note of the front and back of the screen. Unnatural images will be produced when these sides are mistaken.*
- *As dust and oil adhere easily to the screen, when replacing, always put on gloves (also protects against hazards).*
- *As the lenticular sheet is very thin and tears easily, handle it with extreme care.*
- *The fresnel lens is such that convex lenses are arranged in flat. Do not expose it to direct sunlight to prevent fire hazards, burns, and loss of eyesight.*
- *When performing replacements at high places, work very carefully as small mistakes may lead to serious accidents.*

2. PRECAUTIONS FOR PLAYING

- The input function, MULTI ON/OFF (peripheral light amount selection), VIDEO MUTE ON/OFF, COMBINATION ON/OFF (ABL link selection), COLOR MODE 1/2 (white balance selection), TV system selection, and convergence memory state will be recorded in the memory only if the power is turned off using the remote control or tact SW on the rear panel and finish the adjustment mode (if you were set each data in the adjustment mode). (They will not be recorded in the memory if the power is turned off using AC ON/OFF.) When starting or stopping the system by AC ON/OFF under setup conditions for a demonstration, perform the above operations beforehand, record the above in the memory, and then perform AC ON/OFF.
- To mute the image during performance, perform the following steps (1) to (3).

(1) Using an external Personal Computer commands

Example) When muting an image of the unit with ID = 11:

11 A OF → 11 IN ○ → 11 A ON

(Image mute)(Input selection & Image must released)

- : 1 → For VIDEO input
 or
 2 → For Y/C input
 or
 3 → For RGB input

(2) Set the remote control unit or personal computer

VIDEO MUTE ON: Mutes the screen for several ten milli-seconds when switching the input function (VIDEO, Y/C, RGB).

VIDEO MUTE OFF: Will not mute the screen even when the input function is switched.

(3) Settings when the signal is switched between NTSC and PAL using the personal computer

The image may be disturbed momentarily due to the time required for switching the TV format. If the disturbance is great, mute the screen as follows.

Example) Mute the screen when switching from NTSC to PAL.

Initial settings:

TV SYSTEM= AUTO (For details, refer to Chapter 4. 2(2) TV SYSTEM.)

When NTSC signal is input : CONV. MEMO-1

When PAL signal is input : CONV. MEMO-2

Convergence : Adjusted

Input function : Fixed

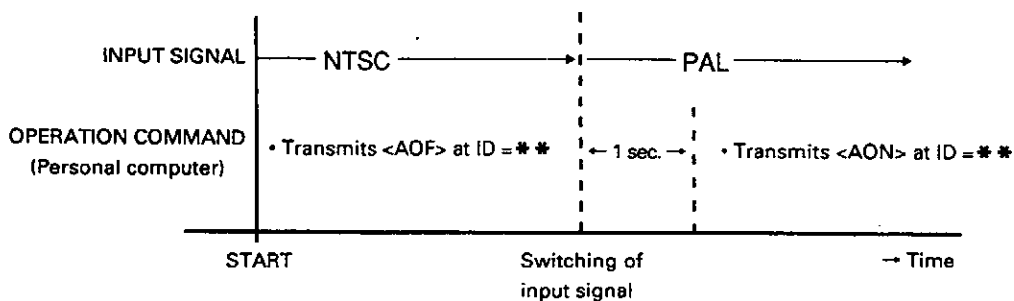

But, <AON> is transmitted more than one second after the PAL signal has been switched.

3. PRECAUTIONS FOR ASSEMBLING AND MAINTENANCE

- Periodically clean the vent nets of the fan of the multi-projection unit to prevent it from clogging.
- In assemblies and maintenance, the service person must move in the cabinet. The following are precautions for this procedure.
 - (1) Do not place load on the screen unit.
(In the procedure, always place weight on the cabinet.
 - (2) Be careful not to hit your head when moving the unit.
 - (3) Do not touch the lens.
 - (4) AS changing the position of the multi-projection unit will change the convergence, do not touch the multi-projection unit.

 Work carried out at high places is extremely hazardous. If tools, etc. are dropped, it will cause not only damage to the equipment but also injuries to men as well. Therefore work carefully.

CHAPTER 6. PRECAUTIONS

1. PRECAUTIONS ON FUNCTION AND PERFORMANCE OF SYSTEM

- The picture may turn to disorder temporarily due to power discharge inside the CRT tube, but it will recover automatically after a few seconds. In the new CRT, the very slight amount of impurities remaining inside (in vacuum) may occasionally evaporate when hit with electron beam. However, this will not occur after the CRT has been used for 100 to 200 hours.
- When the power remains off for some time, it may indicate that a fault has occurred inside. (malfunction of parts). Turn off the main power switch of the multi-projection unit, and after several seconds, turn it on again. If the power goes off again, it indicates a fault. If it works normally, it indicates abnormal operations due to external factor and will not affect operations thereafter.
- If the screen color and brightness is abnormal or the switches do not function, turn off the main power switch once and turn it on again several seconds later.
- In some cases, the screen from appear bluish when seen from the left and slightly reddish when seen from the right. This phenomenon called color shift is inevitable due to the structure of the projection system in which the R G, B tubes are lined up and light is projected from the rear.
- When the one image (still image and caption) is displayed for a long period of time, the image will stick onto the screen and cannot be removed. As this is inevitable due to the projection system, it must be resolved through software contents, displaying method, system structure, etc.
- When bright images are displayed in the dark, the light reflected on the lens will shine in the darkness slightly. This phenomenon called tube-inside reflection is inevitable due to the structure of the projection whose CRT light has been expanded using the lens. (Fig. 6-1.)

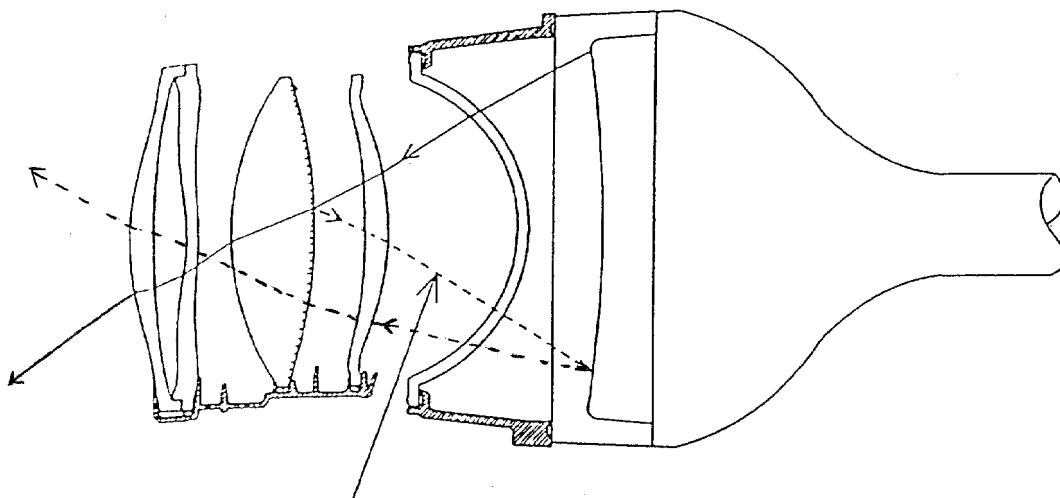

(fig.6-1)

PRECAUTIONS

- When switching between the VIDEO and Y/C input using the EXT-CONTROL terminal for different TV formats, the image will be disturbed for several seconds when they are switched automatically even if TV SYSTEM is set to AUTO.

Example) Image is disturbed.

VIDEO input (NTSC) → Y/C input (PAL)

Image is not disturbed.

VIDEO input (NTSC) → Y/C input (NTSC)

- When the following signals are input, the image may be distorted.
 - VCR signal which repeats copying.
 - VCR signal with copy-guard.
 - Scrambled CATV signal.
 - Signal other than NTSC/PAL standard signal
 - Signals whose sync signal and video signal phases are considerably different.
(In some cases the centers of H and V cannot be adjusted. If adjustments can be performed using the expansion equipment, etc., use it.)
 - Signal with extremely narrow feedback period
- If the power is repeatedly turned on and off by disconnecting the power cord, the count of the hour meter may be incorrect. The hour meter serves as a reference for how long the unit has been used, and the operation is not affected by the count error.

<CUBE Adjustment>

1. Preparations

- ① Connect the power supply, and connect the cable for input signals and ABL link cable (control cable).
- ② Place the connected cables neatly.
- ③ After completing the above ① and ②, turn on the power and perform aging for one hour.
- ④ Prepare the signals required for adjustments.

2. Before Starting Adjustments (Set Conditions) P. 62

- ① Set whether to perform the adjustments using the remote control or personal computer.
- ② Check the TV SYSTEM setting.
Check the convergence memory and white balance memory used for the adjustments.
- ③ Check and set the STATUS.
MULTI ON/OFF, COMBINATION ON/OFF, ABL link switch settings (3-levels).
- ④ Recording the settings in the memory.

3. Setting ID P. 65

- ① Set the ID to each CUBE.

4. Adjusting The Screen

- ① Adjust the size of each screen. P. 71
- ② Adjust the convergence of each screen. P. 72
- ③ Adjust the link of each screen. P. 73
- ④ Adjust the W/B of each screen. P. 88
- ⑤ Adjust the ABL level. P. 92
- ⑥ Adjust the color using the image to be transmitted. P. 93
- ⑦ Check the whole screen.

PRELIMINARY

**PIONEER CUBE SYSTEM
TECHNICAL MANUAL
(Additional version)**

· Before Cube adjustment

· Convergence adjustment

· Hi-scan signal adjustment

· White balance adjustment

This manual has been made for the purpose of explain more detail of adjustment procedure that is difficult to understand with the technical manual for the installation. This manual will be used with the technical manual for the RM-V4000V. The basic point of view is the same as the RM-V2400N.

1996 September

SHIZUOKA PLANT
System Engineering Department

Before Cube adjustment

1. It is important to set the Cube with a mechanic surely.
 - ① Screw on after placing the Cube unit on the right position.
 - ② Attach the slide table part and the base of the frame.
 - ③ Make sure no installation gap between the screens.

2. Before a multi-screen adjustment, make sure the condition of the adjustment on the menu display if the setting of all screens are same.
SW position of the rear panel for each display should be same condition.

3. The adjustment in the field is to take out the difference of each screen mainly.
 - At the factory, a central position and a screen size have been adjusted by using the Monoscope signal, adjustment condition will be changed when different signal is used for it in the field.
 - When there is no require of the image size specially, check the whole tendency and adjust the size of the average majority.
 - … The know-how to complete the adjustment in the short time is not moving the size as much as possible because the miss-convergence comes out when moving.
 - The display has been adjusted White balance by using the Window signal at the factory, try to take out the color balance error of each display mainly after a decision of target of average white balance.

4. In case changing various data at the adjustment causes bad adjustment condition, it is better to try adjustment again after resetting the data to the factory standard .

In the case of the protection works at turning on a power due to odd data setting while convergence adjustment, heal with the following operation:

Leave the unit about 10 seconds with "STAND-BY" (Red LED lights up) mode, then turn OFF/ON the main power SW in order to reset the protection circuit. Next, turn ON the power by issuing a "POC" command by a computer, or turn the power ON by the remote controller within 3

seconds after entering the adjust mode while the unit is in STAND-BY mode. In this case, actual setting of convergence will not be changed though the convergence data on the on-screen-display changes since convergence output is muted internally. Correct the incorrect data which was set by mistake or reset to the factory default data. The mute function is released and convergence adjustment can be started again after normal power OFF/ON cycle.

Convergence adjustment

1. Center position adjustment

POINT

The difference of "PHASE" and "STATIC" adjustment

As the way of moving a display position, each of the deflection and the convergence has the function of "PHASE" and "STATIC".

- "P H A S E" ... Any miss-convergence will not come out since it only changes the timing of the video signal in the position.
- "S T A T I C" ... The miss-convergence of R, G, B comes out due to movement of the projected position of the CRT beam, and re-adjustment of the convergence is necessary. The "STATIC" function causes more DC voltage against the output amplifiers to move the beam and the amplifiers' load may be increased. To fix a data value on "128" beforehand is an ideal. Adjust within 10 mm on the screen is recommended when using "STATIC" of the convergence.

⇒ Adjust the center position with "PHASE" to the utmost.

According to the whole tendency, if the individual screens with the size 95% of the left, 90% of the right are many, it is better to unify to the size of majority. It becomes the same size 95% of the left, 90% of the right with the expanded multi-image. After this adjustment, the phase shift function of MVP (Multi-Video-Processor) can correct simply either side or center without changing the convergence.

CAUTION

Some of the RM-V4000V can not be adjusted "V PHASE" when "multi" function is ON because of the difference of firmware revision. In this case, the center position should be adjusted by the phase adjustment of the MVP before the Cube's adjustment. "V STATIC" of the deflection can be used to move the vertical position If it's impossible to move by the MVP, and do not use "GV STATIC" of the convergence as much as possible.

2. Size adjustment

POINT

The difference of the deflection adjustment and the convergence adjustment

- Two types of the size control are available. One is the deflection adjustment that can control three (RGB) colors simultaneously, and the other is the convergence adjustment that can control the three colors separately. However, the output amplifiers for the convergence adjustment do not have enough room, therefore, the image may have some distortion or power protection may work when a lot of size factors are added at the convergence adjustment.

⇒ It is recommended that set "GH SIZE" and "GV SIZE" of the convergence within 128 ± 10 range, then picture size should be adjusted by the deflection "V SIZE" mainly.

- The size of all individual images must be equal for the length and the width. The screen size that is adjusted in the individual screens becomes the enlarged picture size finally.

- The miss-convergence occurs when changing an image size, in this case, adjust it by using "H.BLK_L" and "H.BLK_R" command in the deflection adjustment mode.

⇒ Refer to the technical manual P73.

3. The adjustment of the high scan signal

(Refer to the technical manual P56 for the memory allocation)

When a high frequency signal is fed, some distortion of the image appear on the display because the data which has been stored at factory is adjusted with standard NTSC signal.

POINT

Adjust by using the command "H.BLK_L" and "H.BLK_R"

- ① When high horizontal frequency signal is fed, the image may be distorted to bend the horizontal line since the blanking width is not proper for the convergence adjustment. It is the same distortion which appears when size is changed.

⇒ Refer to the technical manual P73~ and adjust the horizontal line to fix straight.

- ② When a different frequency signal is fed, the linearity of the deflection changes too. After the adjustment ①, adjust the pitches of each line of the cross hatching signal to be equal.

⇒ At first, adjust for the pitch of the each lines to be equal as the monochromatic green by the point convergence adjustment.

- ③ Check the value of "GH SIZE" after the adjustment ②. (A lot of value of the convergence data may be changed since combination of various kind of waves are used at the point convergence adjustment)

⇒ Reset the original size by using "H SIZE" after resetting "GH SIZE" to "128".

- ④ Adjust the color deviation of R and B (convergence for R and B signal)

4. The adjustment procedure of the point convergence

① Adjust the center portion of the screen.

② Adjust the center cross-line by the point convergence.

③ Find out the biggest part of the color deviation, and make the difference small as much as possible. If the adjustment point is moved widely, the convergence may change not only the adjustment point but around it. (Refer to the technical manual.)

④ Adjust one by one from outside to inside of display.

Check outside once again if there is a difference after finished adjustment at inside of the display.

High scan signal adjustment

1. The RGB input accepts the following frequency signals:
Horizontal : 15 KHz ~ 35 KHz (Automatic)
Vertical : 50 Hz ~ 150 Hz (Automatic)
VGA mode is applied for the RM-V4000V. (refer to Figure 1)
2. Especially becoming a high scan frequency, the rate of the blanking width is increased. The non-display period must be at least **6.3 μ sec.** for the horizontal and **1.3 m sec.** for the vertical interval. All picture image can not be displayed and hard to reject picture distortion when blanking interval periods are short.
3. When horizontal frequency is high and the display area is wide (= blanking period is short), a vertical streak may be seen on the left side of the screen. To solve it, adjust "STATIC" of convergence to move left side for RGB signals (Max. is 10 mm), then adjust "PHASE" of deflection to move right side. In this case, miss-convergence may occur due to the adjustment of the "STATIC".
4. The convergence amplifiers will have more load than normal condition in the convergence adjustment mode when a high scan signal is fed. Once miss-adjustment occurs, it may results more high load against the amplifiers and the protection circuit may turn the cube OFF, even if convergence can be adjusted similarly on the screen.
5. The defective symptoms due to an overload of convergence are follows:
 - Power Down (the power supply P.D. or the convergence P.D.)
 - The vertical direction scan of the top portion of the screen is disordered.
 - The vertical line shakes with the cross hatching signal.
 - The brightness of the image changes during the convergence adjustment.

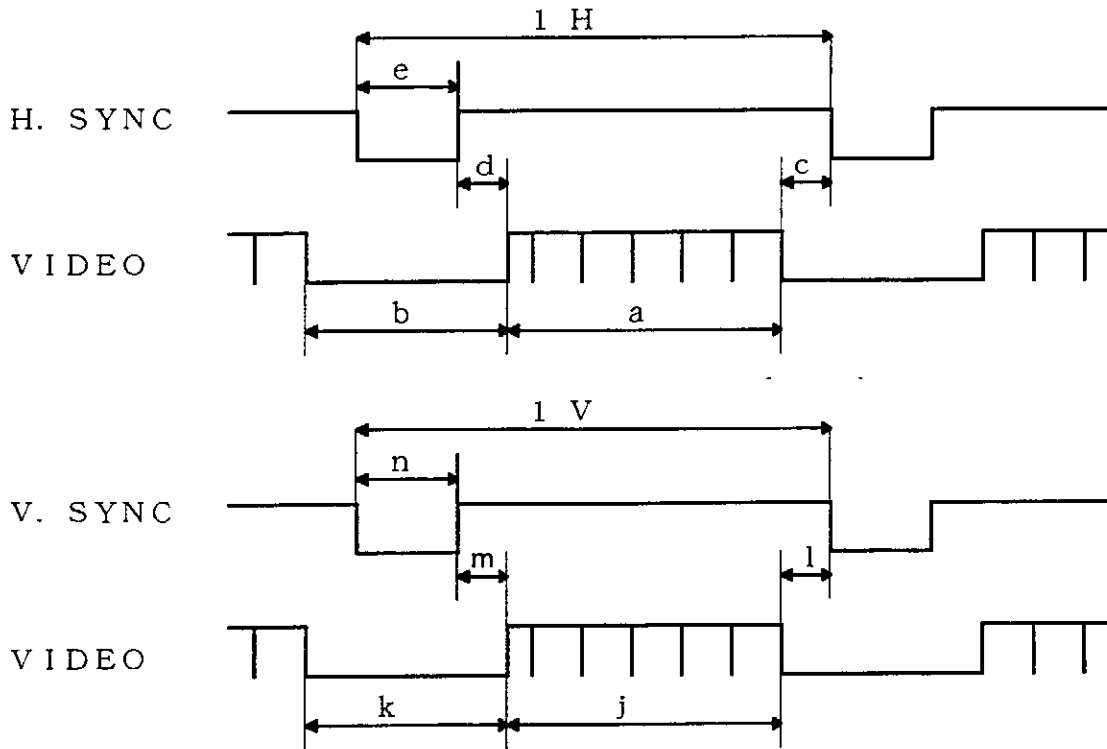

Display dot		640 * 350	640 * 400	640 * 480	640 * 480	
Clock frequency [MHz]		25. 175			30. 240	
H	Frequency [kHz]	31. 469			35. 0	
	Scan time [μ S]	1 H	31. 778			28. 57
	Display [μ S]	a	25. 422			21. 16
	Non-display [μ S]	b	6. 356			7. 41
	Front porch	c	0. 636			2. 12
	Back porch	d	1. 907			3. 17
	H. SYNC	e	3. 713			2. 12
V	Frequency [Hz]	70. 08	70. 08	59. 94	66. 67	
	Scan time [mS]	1 V	14. 268	14. 268	16. 683	15. 0
	Display [mS]	j	11. 123	12. 711	15. 254	13. 7
	Non-display [mS]	k	3. 145	1. 557	1. 429	1. 3
	Front porch	l	1. 176	0. 381	0. 381	0. 086
	Back porch	m	1. 906	1. 112	1. 048	1. 11
	V. SYNC	n	0. 064	0. 064	0. 064	0. 086

(Figure 1) Example of signal timing

White balance adjustment

1. White balance adjustment

As the difference with the RM-V2000 series model, the “Green Low” and the “Green High” adjustment are additional. By this, in case of the white balance adjustment for the RM-V4000V series model, the contrast and brightness for each display should be set to the same value. The ABL adjustment takes difficulty if the contrast and brightness value is different on each display.

2. The adjustment of the low light and the high light effect respectively as a brightness adjustment function to the signal of low and high level. But, they influence a mutual brightness each other. Even if the middle level is well balanced, the brightness doesn't match with the others screen in the point of the ABL operation level or the light starting the shine when the balance is collapsing for the low and the high adjustment.

3. ABL adjustment

ABL (Auto Brightness Limit) is the circuit which limits a beam current automatically to protect that the brightness of the monitor TV (Cube) becomes high too much to destroy the CRT. It detects a beam current level on the 2nd side of the FBT, it lowers a contrast and a brightness and makes not to rise above a certain level.

4. ABL-GAIN adjustment

“ABL-GAIN” reduces the difference of each ABL operating point when putting together the multi screen Cube. ABL works to limit the light when the total anode current which flows through the CRT of the RGB becomes 1.4 mA.

In case, A, B are two pieces of Cube like the Figure-2, ABL works at the point of ① in the light when the luminous efficiency of the set of A is bad even if both CRT begin to shine at the same time. On the other hand, as for B, ABL works at the point of ② which is lighter than A unit.

“ABL_GAIN” increases the ABL current in appearance by the control of the microprocessor and ABL works early timing. By decreasing the value of “ABL_GAIN” (default is MAX.) for B unit, the ABL current is increased in

appearance then ABL works at the light which is the same brightness point as A unit. In this case, the whole image becomes dark because the “ABL_GAIN” means to uniform the light Cube to the dark one. This adjustment is required when old and new CRT are installed in a wall and there is a difference of substantial lighting ability among these units.

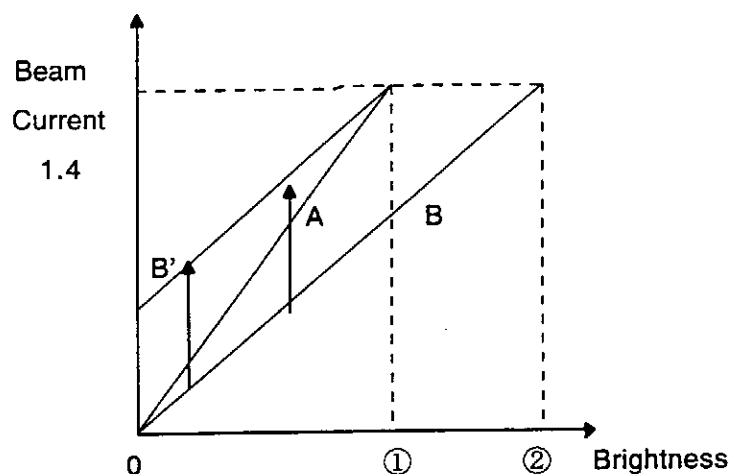

Figure-2

5. ABL-LEVEL adjustment

“ABL-LEVEL” works only when combination is ON and link cables are connected. It reduces the difference of each Cube’s brightness in case of ABL operation. The ABL combination is the function to work ABL of all connected Cube uniformly. However, the change of the brightness will not be the same condition by only connecting the cables if the operating point on each cube is different. “ABL_LEVEL” reduces a difference with the ABL variation of each Cube when connected. The microprocessor controls the contrast and the brightness level when the combination is ON. The “ABL_LEVEL” should be adjusted not to produce a brightness change at combination mode ON/OFF cycle with condition of 100% white signal is fed. Adjustment can be done only when the combination mode is ON. The “ABL combination ratio” SW (For only US model) also effective only when the combination mode is ON.

Before adjusting “ABL_GAIN”, “ABL_LEVEL”, the R, G, B LOW, and HIGH adjustment must be done.

Free Manuals Download Website

<http://myh66.com>

<http://usermanuals.us>

<http://www.somanuals.com>

<http://www.4manuals.cc>

<http://www.manual-lib.com>

<http://www.404manual.com>

<http://www.luxmanual.com>

<http://aubethermostatmanual.com>

Golf course search by state

<http://golfingnear.com>

Email search by domain

<http://emailbydomain.com>

Auto manuals search

<http://auto.somanuals.com>

TV manuals search

<http://tv.somanuals.com>