

Pioneer *sound.vision.soul*

Audio Multi-Channel Receiver

SX-316-S

Operating Instructions

IMPORTANT



The lightning flash with arrowhead symbol, within an equilateral triangle, is intended to alert the user to the presence of uninsulated "dangerous voltage" within the product's enclosure that may be of sufficient magnitude to constitute a risk of electric shock to persons.

CAUTION

**RISK OF ELECTRIC SHOCK
DO NOT OPEN**

CAUTION:

TO PREVENT THE RISK OF ELECTRIC SHOCK, DO NOT REMOVE COVER (OR BACK). NO USER-SERVICEABLE PARTS INSIDE. REFER SERVICING TO QUALIFIED SERVICE PERSONNEL.



The exclamation point within an equilateral triangle is intended to alert the user to the presence of important operating and maintenance (servicing) instructions in the literature accompanying the appliance.

D3-4-2-1-1_En-A

WARNING

To prevent a fire hazard, do not place any naked flame sources (such as a lighted candle) on the equipment.

D3-4-2-1-7a_A_En

WARNING

Before plugging in for the first time, read the following section carefully.

The voltage of the available power supply differs according to country or region. Be sure that the power supply voltage of the area where this unit will be used meets the required voltage (e.g., 230 V or 120 V) written on the rear panel.

D3-4-2-1-4_A_En

WARNING

This equipment is not waterproof. To prevent a fire or shock hazard, do not place any container filled with liquid near this equipment (such as a vase or flower pot) or expose it to dripping, splashing, rain or moisture.

D3-4-2-1-3_A_En

Operating Environment

Operating environment temperature and humidity:
+5 °C to +35 °C (+41 °F to +95 °F); less than 85 %RH
(cooling vents not blocked)

Do not install this unit in a poorly ventilated area, or in locations exposed to high humidity or direct sunlight (or strong artificial light)

D3-4-2-1-7c_A_En

This product is for general household purposes. Any failure due to use for other than household purposes (such as long-term use for business purposes in a restaurant or use in a car or ship) and which requires repair will be charged for even during the warranty period.

K041_En

If the AC plug of this unit does not match the AC outlet you want to use, the plug must be removed and appropriate one fitted. Replacement and mounting of an AC plug on the power supply cord of this unit should be performed only by qualified service personnel. If connected to an AC outlet, the cut-off plug can cause severe electrical shock. Make sure it is properly disposed of after removal. The equipment should be disconnected by removing the mains plug from the wall socket when left unused for a long period of time (for example, when on vacation).

D3-4-2-2-1a_A_En

CAUTION

The ϕ STANDBY/ON switch on this unit will not completely shut off all power from the AC outlet. Since the power cord serves as the main disconnect device for the unit, you will need to unplug it from the AC outlet to shut down all power. Therefore, make sure the unit has been installed so that the power cord can be easily unplugged from the AC outlet in case of an accident. To avoid fire hazard, the power cord should also be unplugged from the AC outlet when left unused for a long period of time (for example, when on vacation).

D3-4-2-2-2a_A_En

VENTILATION CAUTION

When installing this unit, make sure to leave space around the unit for ventilation to improve heat radiation (at least 40 cm at top, 10 cm at rear, and 20 cm at each side).

WARNING

Slots and openings in the cabinet are provided for ventilation to ensure reliable operation of the product, and to protect it from overheating. To prevent fire hazard, the openings should never be blocked or covered with items (such as newspapers, table-cloths, curtains) or by operating the equipment on thick carpet or a bed.

D3-4-2-1-7b_A_En

Voltage selector

You can find the voltage selector switch on the rear panel of multi-voltage models.

The factory setting for the voltage selector is 220 V. Please set it to the correct voltage for your country or region.

- Saudi Arabia operates on 127V and 220V mains voltage. Please set to the correct voltage before using.
 - For Taiwan, please set to 110 V before using.
 - For Mexico, please set to 120 V to 127 V before using.
- Before changing the voltage, disconnect the AC power cord. Use a medium size screwdriver to change the voltage selector switch.

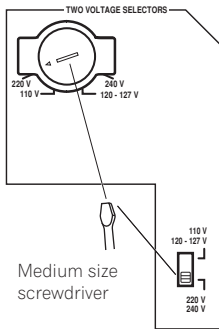

D3-4-2-1-5_En

POWER-CORD CAUTION

Handle the power cord by the plug. Do not pull out the plug by tugging the cord and never touch the power cord when your hands are wet as this could cause a short circuit or electric shock. Do not place the unit, a piece of furniture, etc., on the power cord, or pinch the cord. Never make a knot in the cord or tie it with other cords. The power cords should be routed such that they are not likely to be stepped on. A damaged power cord can cause a fire or give you an electrical shock. Check the power cord once in a while. When you find it damaged, ask your nearest PIONEER authorized service center or your dealer for a replacement. **5002_En**

For Taiwan exclusively Taiwanese two pin flat-bladed plug

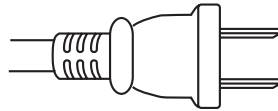

Replacement and mounting of an AC plug on the power supply cord of this unit should be performed only by qualified service personnel.

IMPORTANT: THE MOULDED PLUG

This appliance is supplied with a moulded three pin mains plug for your safety and convenience. A 10 amp fuse is fitted in this plug. Should the fuse need to be replaced, please ensure that the replacement fuse has a rating of 10 amps and that it is approved by ASTA or BSI to BS1362.

Check for the ASTA mark  or the BSI mark  on the body of the fuse.

If the plug contains a removable fuse cover, you must ensure that it is refitted when the fuse is replaced. If you lose the fuse cover the plug must not be used until a replacement cover is obtained. A replacement fuse cover can be obtained from your local dealer.

If the fitted moulded plug is unsuitable for your socket outlet, then the fuse shall be removed and the plug cut off and disposed of safely. There is a danger of severe electrical shock if the cut off plug is inserted into any 13 amp socket.

If a new plug is to be fitted, please observe the wiring code as shown below. If in any doubt, please consult a qualified electrician.

IMPORTANT: The wires in this mains lead are coloured in accordance with the following code:

Blue : Neutral Brown : Live

As the colours of the wires in the mains lead of this appliance may not correspond with the coloured markings identifying the terminals in your plug, proceed as follows :

The wire which is coloured BLUE must be connected to the terminal which is marked with the letter **N** or coloured BLACK.

The wire which is coloured BROWN must be connected to the terminal which is marked with the letter **L** or coloured RED.

How to replace the fuse: Open the fuse compartment with a screwdriver and replace the fuse.

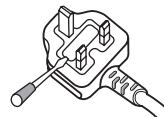

D3-4-2-1-2-2_B_En

Contents

01 Before you start

Checking what's in the box	5
Loading the batteries	5
Using the remote control	5
Installing the receiver	6
Using the Quick Setup	6

02 Connecting up

Making cable connections	7
Audio cables (analog)	7
Coaxial and Optical digital audio cables	7
Connecting to a TV and DVD recorder or player	8
Connecting a tape deck or VCR	8
Connecting other digital components	9
Connecting antennas	9
FM wire antenna	9
AM loop antenna	10
Using external antennas	10
Connecting the speakers	11
Speaker terminals	12
Hints on speaker placement	12
Plugging in	12

03 Controls and displays

Front panel	13
Display	14
Remote control	16
About the WMA9 Pro decoder	18

04 Listening to your system

Auto playback	19
Listening in surround sound	19
Using the Advanced surround effects	20
Setting the effect options	20
Using the Virtual Surround Back mode (VSB)	21
Listening in stereo	21
Using the Sound Retriever	22

05 The System Setup menu

Making receiver settings from the System Setup menu	23
Channel level	23
Speaker Distance	24
Dynamic Range Control Setup	24
Dual Mono Setup	24
LFE Attenuator Setup	24

06 Using the tuner

Listening to the radio	25
Saving station presets	25
Naming station presets	25
Listening to station presets	25
Changing the frequency step	26

07 Additional information

Troubleshooting	27
Resetting the main unit	28
Cleaning the unit	28
Specifications	29

Chapter 1: Before you start

Checking what's in the box

Please check that you've received the following supplied accessories:

- AM loop antenna
- FM wire antenna
- AA size IEC R6 dry cell batteries (to confirm system operation) x 2
- Remote control
- Power cords (make sure you use the correct cord for your country/region):
Round 2-pin type, flat blade 2-pin type and UK 3-pin type
- J-shaped plug
- These operating instructions

Loading the batteries

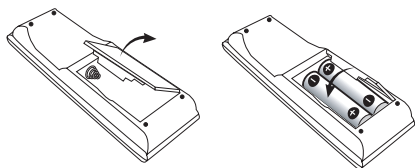

Important

Incorrect use of batteries may result in such hazards as leakage and bursting. Observe the following precautions:

- Never use new and old batteries together.
- Insert the plus and minus sides of the batteries properly according to the marks in the battery case.

- Batteries with the same shape may have different voltages. Do not use different batteries together.
- When disposing of used batteries, please comply with governmental regulations or environmental public instruction's rules that apply in your country/area.



WARNING

- Do not use or store batteries in direct sunlight or other excessively hot place, such as inside a car or near a heater. This can cause batteries to leak, overheat, explode or catch fire. It can also reduce the life or performance of batteries.

Using the remote control

Keep in mind the following when using the remote control:

- Make sure that there are no obstacles between the remote and the remote sensor on the unit.
- The remote has a range of about 7 m.
- Remote operation may become unreliable if strong sunlight or fluorescent light is shining on the unit's remote sensor.
- Remote controllers for different devices can interfere with each other. Avoid using remotes for other equipment located close to this unit.
- Replace the batteries when you notice a fall off in the operating range of the remote.

Installing the receiver

- When installing this unit, make sure to put it on a level and stable surface.

Don't install it on the following places:

- on a color TV (the screen may distort)
- near a cassette deck (or close to a device that gives off a magnetic field). This may interfere with the sound.
- in direct sunlight
- in damp or wet areas
- in extremely hot or cold areas
- in places where there is vibration or other movement
- in places that are very dusty
- in places that have hot fumes or oils (such as a kitchen)

Using the Quick Setup

You can use the Quick Setup to get your system up and running with just a few button presses. The receiver automatically makes the necessary settings after you have selected your room size and listening position.

If you want to make more specific settings, refer to *The System Setup menu* on page 23.

Use the front panel controls for the steps below.



1 Press  **STANDBY/ON to switch on.**

2 Press **QUICK SETUP.**

3 Use the MULTI JOG dial to choose your room size.

Depending on the distance of your speakers from the listening position, choose between small, medium, or large (**S**, **M** or **L**), **M** being an average-sized room.

4 Press **ENTER.**

5 Use the MULTI JOG dial to choose your listening position.

You can cycle between the following choices:

- **FWD** – If you are nearer to the front speakers than the surround speakers
- **MID** – If you are equal distance from the front and surround speakers
- **BACK** – If you are nearer to the surround speakers than the front speakers

6 Press **ENTER to confirm your setup.**

The display shows the room size and listening position that you have selected.

Chapter 02: Connecting up

Making cable connections

Make sure not to bend the cables over the top of this unit. If this happens, the magnetic field produced by the transformers in this unit may cause a humming noise from the speakers.



Important

- Before making or changing any connections, switch off the power and disconnect the power cable from the AC outlet.
- Before unplugging the power cord, switch the power into standby.

Audio cables (analog)

Use audio cables (not supplied) to connect audio components.

Connect red plugs to **R** (right) jacks, white plugs to **L** (left).

Be sure to insert completely.

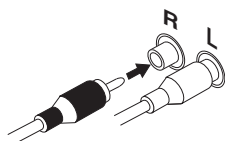

Coaxial and Optical digital audio cables

Coaxial digital audio cables (standard video cables can also be used) or optical cables are used to connect digital components to this receiver.

Be sure to insert completely.

Coaxial digital audio cable
(or standard video cable)

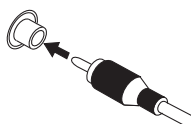

Optical cable

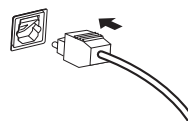

- When inserting the plug of an optical cable, be careful not to damage the shutter protecting the optical jack.
- Do not bend optical cables around sharp corners as they may be damaged. When storing, coil loosely.

Connecting to a TV and DVD recorder or player

The diagram below shows the connections for a basic home theater setup of a TV, DVD recorder (or player) and this receiver.

Audio is output from the DVD recorder's coaxial digital audio jack, while the video output goes to the TV. Also shown is a stereo analog audio connection from your TV to this receiver so you can enjoy sound from this receiver when watching TV programs.

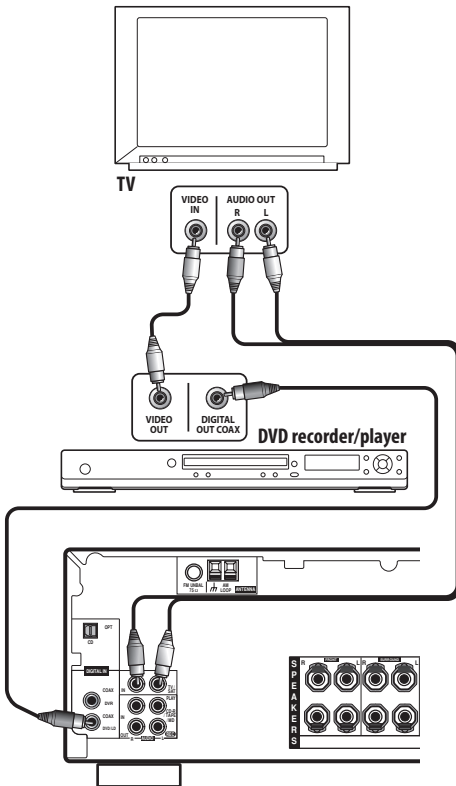

Note

- If your DVD player only has an optical digital output, you can still connect it to this receiver using the **CD OPT** optical digital jack. If you choose to do so, you will have to select the **CD** input function when you want to hear playback from your DVD player.

Connecting a tape deck or VCR

The diagram below shows a tape deck or VCR connected to the receiver using two sets of stereo analog audio cables, one set for the audio input and one set for output from the receiver for recording.

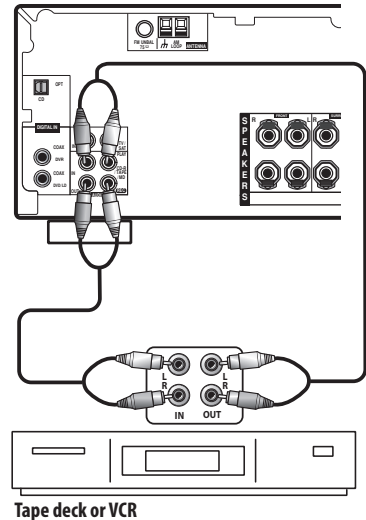

AM loop antenna

Assemble the antenna and connect to the receiver. Attach (if necessary) and face in the direction that gives the best reception.

If you want to attach the loop antenna to a wall, assemble as shown below.

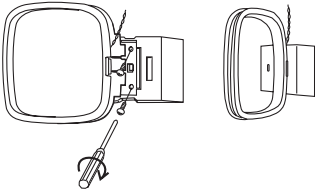

Antenna snap connectors

Twist the exposed wire strands together and insert into the hole, then snap the connector shut.

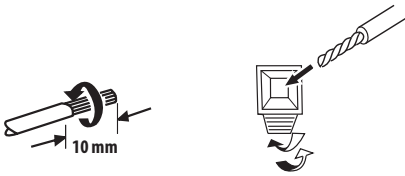

Using external antennas

To improve FM reception

Connect an external FM antenna.

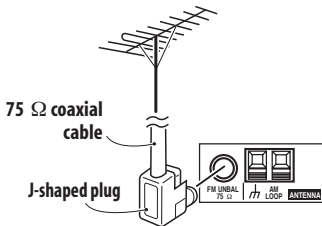

To improve AM reception

Connect a 5 m to 6 m length of vinyl-coated wire to the AM antenna terminal without disconnecting the supplied AM loop antenna.

For the best possible reception, suspend horizontally outdoors.

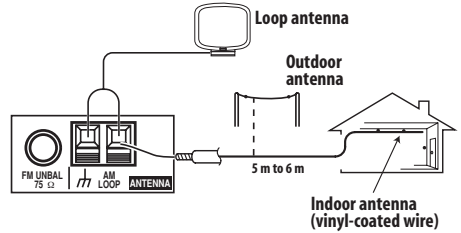

Connecting the speakers

The diagram below shows a complete surround sound setup of six speakers set up in a typical configuration. For the best sound, try to follow this setup in your room as closely as possible. Make sure the positive (colored) and negative (black) terminals on the receiver match those on the speakers. You can use speakers with a nominal impedance between 8 Ω and 16 Ω .

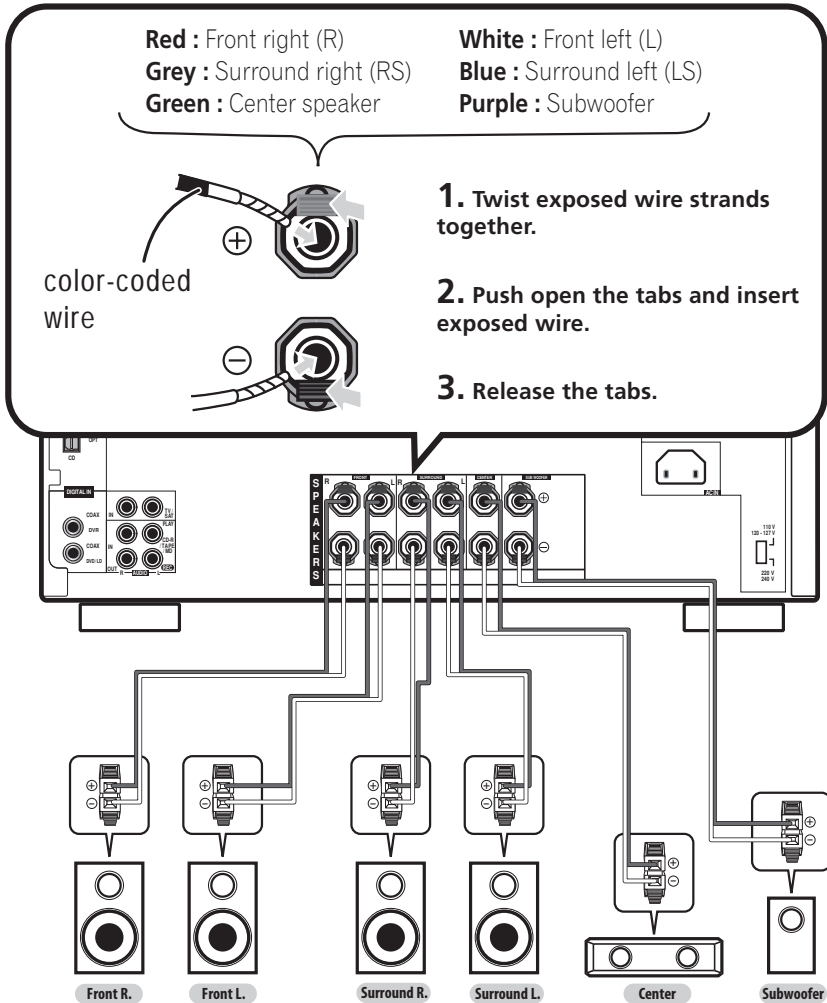

Speaker terminals

Make sure that all the bare speaker wire is twisted together and inserted fully into the speaker terminal. If any of the bare speaker wire is touching the back panel when you switch the unit on, the power may cut off as a safety measure. Use good quality speaker wire to connect the speakers to the receiver.



Caution

- These speaker terminals carry **HAZARDOUS LIVE** voltage. To prevent the risk of electric shock when connecting or disconnecting the speaker cables, disconnect the power cord before touching any uninsulated parts.

Hints on speaker placement

Speakers are usually designed with a particular placement in mind. Some are designed to be floorstanding, while others should be placed on stands to sound their best. Some should be placed near a wall; others should be placed away from walls. We have provided a few tips on getting the best sound from your speakers (following), but you should also follow the guidelines on placement that the speaker manufacturer provided with your particular speakers to get the most out of them.

- Place the front left and right speakers at equal distances from the TV.
- When placing speakers near the TV, we recommend using magnetically shielded speakers to prevent possible interference, such as discoloration of the picture when the TV is switched on. If you do not have magnetically shielded speakers and notice discoloration of the TV picture, move the speakers farther away from the TV.
- Place the center speaker above or below the TV so that the sound of the center channel is localized at the TV screen.

- If possible, place the surround speakers slightly above ear level.
- Try not to place the surround speakers further away from the listening position than the front and center speakers. Doing so can weaken the surround sound effect.



Caution

- If you choose to install the center speaker on top of the TV, be sure to secure it with putty, or by other suitable means, to reduce the risk of damage or injury resulting from the speaker falling from the TV in the event of external shocks such as earthquakes.
- Make sure no exposed speaker wire is touching the rear panel, this may cause the receiver to turn off automatically.
- These speaker terminals are hazardous when live. To prevent the risk of electric shock when connecting or disconnecting the speaker cables, disconnect the power cable.

Extra Power mode speaker setup

See *Using the Advanced surround effects* on page 20 to switch on the Extra Power mode (**EX POWER**).

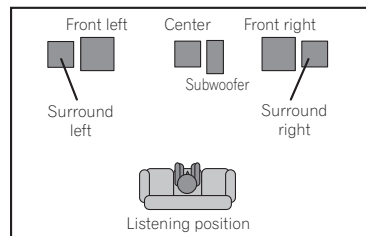

Plugging in

After making sure that everything is connected properly, connect the attached power cable to a wall outlet.

Chapter 3: Controls and displays

Front panel

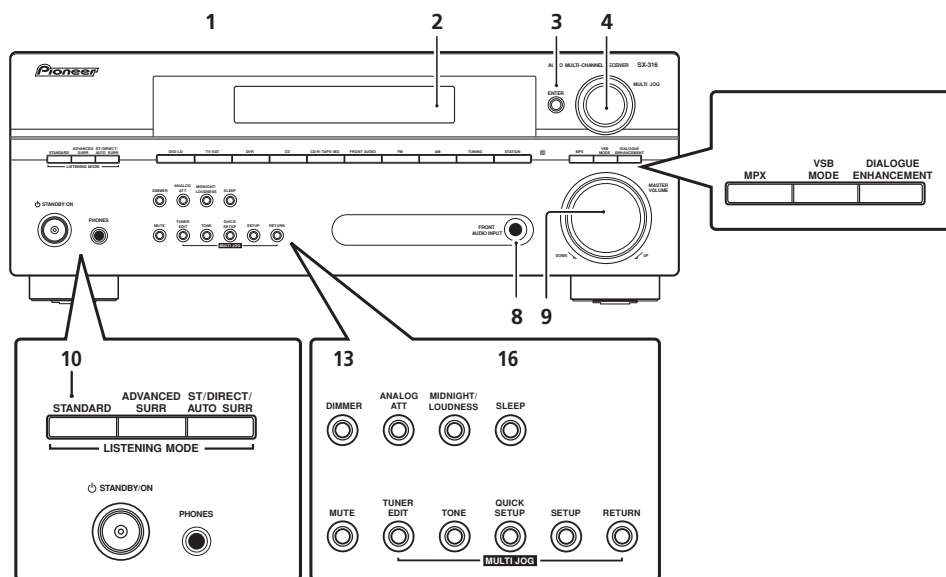

1 Input select buttons

Press to select an input source.

2 Character display

3 ENTER

4 MULTI JOG dial

5 MPX

Use to switch between auto stereo and mono reception of FM broadcasts. If the signal is weak then switching to mono will improve the sound quality.

6 VSB MODE

Selects the Virtual Surround Back (VSB) mode.

7 DIALOGUE ENHANCEMENT

This feature localizes dialog in the center channel to make it stand out from other background sounds in a TV or movie soundtrack.

8 FRONT AUDIO INPUT

9 MASTER VOLUME

Use to set the listening volume.

10 LISTENING MODE buttons

STANDARD

Press for Standard decoding and to switch between Pro Logic II options (page 19).

ADVANCED SURR

Switches between the various surround modes (page 20).

ST/DIRECT/AUTO SURR

Switches between direct and stereo playback. Direct playback bypasses the tone controls for the most accurate reproduction of a source (page 21). Also selects the Auto Surround mode (*Auto playback* on page 19).

11  **STANDBY/ON**

Switches the receiver between standby and on.

12 PHONES jack**13 DIMMER**

Dims or brightens the display.

14 ANALOG ATT

Attenuates (lowers) the level of an analog input signal to prevent distortion.

15 MIDNIGHT/LOUDNESS

These features give you good sound at low volume levels when listening to movie (Midnight) or music (Loudness) sources. Press to switch between **MIDNIGHT**, **LOUDNESS**, and **OFF**.

16 SLEEP

Press to change the amount of time before the receiver switches into standby (**30 min – 60 min – 90 min – Off**).

17 MUTE

Mutes/unmutes the sound.

18 TUNER EDIT

Press to memorize and name a station for recall (page 25).

19 TONE

Press this button to access the bass and treble controls, which you can then adjust with the **MULTI JOG** dial.

20 QUICK SETUP

See *Using the Quick Setup* on page 6.

21 System Setup menu controls**SETUP**

Press to access the System Setup menu (page 23).

RETURN

Confirm and exit the current menu screen.

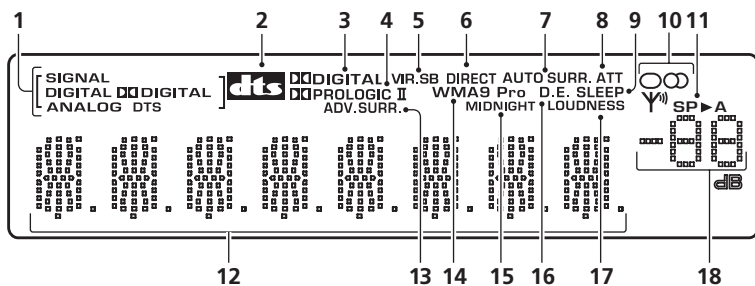
Display**1 SIGNAL indicators**

Lights to indicate the type of input signal assigned for the current component:

DIGITAL

Lights when the **DVD/LD**, **DVR** or **CD** function is selected.

DIGITAL

Lights when a Dolby Digital¹ encoded signal is detected.

ANALOG

Lights when an analog signal is detected.

DTS

Lights when a DTS² encoded audio signal is detected.

2

Lights to indicate decoding of a DTS multichannel signal.

3 **DIGITAL**

Lights to indicate decoding of a Dolby Digital multichannel signal.

4 **PRO LOGIC II**

Lights to indicate Pro Logic II decoding (see *Listening in surround sound* on page 19 for more on this).

5 **VIR. SB**

Lights during Virtual surround back processing (page 21).

6 **DIRECT**

Lights when source direct playback is in use. Direct playback bypasses the tone controls for the most accurate reproduction of a source.

7 **AUTO SURR.**

Lights when the Auto Surround feature is switched on (see *Auto playback* on page 19).

8 **ATT**

Lights when **ANALOG ATT** is used to attenuate (reduce) the level of the analog input signal.

9 **SLEEP**

Lights when the receiver is in sleep mode.

10 **Tuner indicators**

/ **MONO**

Lights when the mono mode is set using the **MPX** button.

/ **STEREO**

Lights when a stereo FM broadcast is being received in auto stereo mode.

/ **TUNED**

Lights when a broadcast is being received.

11 **Speaker indicator**

Shows if the speaker system is on or not. **SP▶A** means the speakers are switched on. **SP▶** means the headphones are connected.

12 **Character display**

13 **ADV.SURR. (Advanced Surround)**

Lights when one of the Advanced Surround modes has been selected.

14 **WMA9 Pro**

Lights to indicate decoding of a WMA9 Pro signal.

15 **MIDNIGHT**

Lights during Midnight listening.

16 **D.E.**

Lights when Dialog Enhancement (**DIALOG E**) is switched on.

17 **LOUDNESS**

Lights during Loudness listening.

18 **Master volume level**

Shows the overall volume level. **---dB** indicates the minimum level, and **- 0 dB** indicates the maximum level.

Note

¹ Manufactured under license from Dolby Laboratories. "Dolby", "Pro Logic", and the double-D symbol are trademarks of Dolby Laboratories.

² "DTS" and "DTS 96/24" are trademarks of Digital Theater Systems, Inc.QVTD,mmi NVUc /T0

Remote control

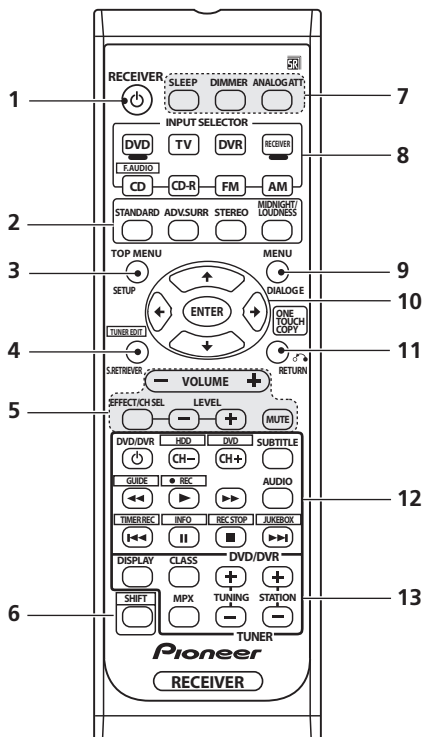

1 RECEIVER

Switches the receiver between standby and on.

2 Listening mode buttons

STANDARD

Press for Standard decoding and to switch between Pro Logic II options (page 19).

ADV.SURR.

Switches between the various surround modes (page 20).

STEREO

Switches between direct and stereo playback. Direct playback bypasses the tone controls for the most accurate reproduction of a source (page 21). Also selects the Auto Surround mode (*Auto playback* on page 19).

MIDNIGHT/LOUDNESS

These features give you good sound at low volume levels when listening to movie (Midnight) or music (Loudness) sources. Press to switch between **MIDNIGHT**, **LOUDNESS**, and **OFF**.

3 TOP MENU

Displays the disc 'top' menu of a DVD disc.

SETUP

Press to access the System Setup menu (page 23).

4 TUNER EDIT*

Press to memorize and name a station for recall (page 25).

Also functions as the SETUP button for DVD/DVR units.

S. RETRIEVER

Press to restore CD quality sound to compressed audio sources (page 22).

5 RECEIVER CONTROL buttons

VOLUME +/-

Use to set the listening volume.

EFFECT/CH SEL

Press repeatedly to select a channel, then use **LEVEL +/-** to adjust the level (page 24). Also adjusts the level of the Advanced Surround effects as well as Dolby Pro Logic II Music parameters (page 20). You can then use the **LEVEL +/-** buttons to make these adjustments.

LEVEL +/-

Use to adjust the effect and channel levels.

MUTE

Mutes/unmutes the sound.

6 SHIFT

Press to access commands in a rectangle (above the buttons) on the remote. These buttons are marked with an asterisk(*) in this section.

7 SLEEP

Press to change the amount of time before the receiver switches into standby (**30 min – 60 min – 90 min – Off**).

DIMMER

Dims or brightens the display.

ANALOG ATT

Attenuates (lowers) the level of an analog input signal to prevent distortion.

8 INPUT SELECTOR buttons

Press to select an input source (press **DVD/DVR** to use the DVD player/recorder controls on the remote).

RECEIVER

Use to switch to the receiver controls on the remote control. Also used when setting up the surround sound for the receiver (page 23).

9 MENU

Displays the disc menu of DVD-Video discs.

DIALOG E

This feature localizes dialog in the center channel to make it stand out from other background sounds in a TV or movie soundtrack.

10 ↑↓←→/ENTER

11 RETURN









Confirm and exit the current menu screen.

ONE TOUCH COPY*

Copies the currently playing title from DVD to HDD or vice-versa.

12 DVD/DVR control buttons

You can use these buttons to control a Pioneer DVD player or recorder connected to your system (press **DVD/DVR** to access the below controls).

Button	What it does
DVD/DVR 	Turns DVD player or DVD recorder power on/off.
AUDIO	Changes the audio language or channel.
SUBTITLE	Displays/changes the subtitles on multilingual DVD-Video discs.
CH +/-	Switches channels.
	Starts/resumes normal playback.
	Pauses/unpauses a disc.
	Stops playback.
	Press to start fast reverse scanning.
	Press to start fast forward scanning.
	Skips to the start of the current track or chapter, then previous tracks/chapters.
	Skips to the next track or chapter.
HDD/DVD*	Switch between the hard disk and DVD controls for DVD/HDD recorders.
GUIDE*	Displays the guides on a DVD recorder.
	Starts recording.
TIMER REC*	Accesses the timer recording menu.
INFO*	Displays additional EPG information.
REC STOP*	Stops recording.
JUKEBOX*	Switches to the Jukebox feature.
TUNER EDIT*	Press to access the SETUP menu .

Radio displays

stations can be used to find (page 25) and the **STATION** button is used to select preset radio

to play between station preset buttons (see tip on page 25).

to return the three banks of automatic presets (page 25).

to switch between auto stereo and mono reception of FM broadcasts. If the car is in mono then switching to mono will improve sound quality.

WMA9 Pro decoder

The car has an on-board Windows Media® Professional (WMA9 Pro) decoder, so it can be used to playback WMA9 Pro-encoded audio files using a coaxial or optical digital audio output when connected to a WMA9 Pro-compatible player. However, the connected DVD player, set-top box, etc. must be able to output WMA9 Pro format audio signals through a coaxial or optical digital output.



Microsoft, Windows Media®, and the Windows logo are trademarks, or registered trademarks of Microsoft Corporation in the United States and/or other countries.

Chapter 4: Listening to your system

Important

- Certain features explained in this section will not be possible depending on the source (for example, PCM 88.2 kHz / 96 kHz, DTS 96 kHz (24 bit) or WMA 9 Pro sources).

Auto playback

The simplest, most direct listening option is the Auto Surround feature. With this, the receiver automatically detects what kind of source you're playing and selects multichannel or stereo playback as necessary.¹

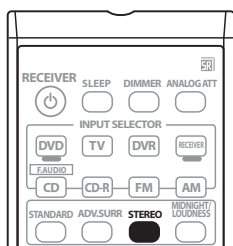

- **While listening to a source, press STEREO for auto playback of a source.**

Press repeatedly until **AUTO SURR.** shows briefly in the display (it will then show the decoding or playback format). Check the digital format indicators in the display to see how the source is being processed.

Listening in surround sound



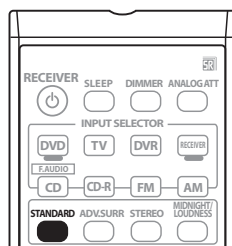

Using this receiver, you can listen to any source in surround sound. However, the options available will depend on the type of source you're listening to.

- **While listening to a source, press STANDARD.**



If the source is Dolby Digital, DTS, or Dolby Surround encoded, the proper decoding format will automatically be selected and shows in the display.

*With two channel sources, press **STANDARD** repeatedly to select from:*

-  **Pro Logic II MOVIE** – Up to 5.1 channel sound, especially suited to movie sources
-  **Pro Logic II MUSIC** – Up to 5.1 channel sound, especially suited to music sources
-  **Pro Logic II GAME** – Up to 5.1 channel sound, especially suited to video games
-  **PRO LOGIC** – 4.1 channel surround sound (sound from the surround speakers is mono)

Note

¹ • Stereo surround (matrix) formats are decoded accordingly using  **Pro Logic II MOVIE** (see *Listening in surround sound* above for more on these decoding formats).

- The Auto Surround feature is canceled if you connect headphones.

Using the Advanced surround effects

Try different settings with various soundtracks to see which you like.

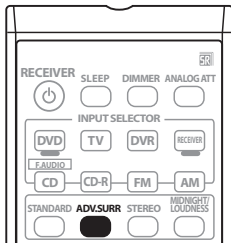

- Press **ADV.SURR.(ADVANCED SURR)** repeatedly to select a listening mode.
 - **ADV. MOVIE** – Suitable for movie sources.
 - **ADV. MUSIC** – Suitable for music sources.
 - **TV SURR.** – Provides surround sound for both mono and stereo TV sources.
 - **SPORTS** – Suitable for sports programs.
 - **ADV. GAME** – Suitable for video games.
 - **EXPANDED** – Simulates multichannel surround sound for two-channel sources.¹
 - **EX.POWER (Extra Power)** – Gives multichannel sound to a stereo source, using all of your speakers.
 - **VIR. SURR.** – A virtual surround effect using just the subwoofer and front speakers.
 - **PHONESUR. (Phones Surround)** – Creates the effect of overall surround with headphones.

Setting the effect options

When using surround effects, there are a number of settings you can adjust.

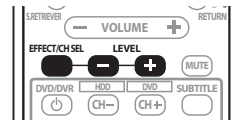

1 Press EFFECT/CH SEL repeatedly to select the setting you want to adjust.

Depending on the current status / mode of the receiver, certain options may not appear. Check the table below for notes on this.

2 Use the LEVEL +/- buttons to set it as necessary.

See the table below for the options available for each setting. The defaults, if not stated, are listed in bold.

3 Press EFFECT/CH SEL again to adjust other settings.

Setting	What it does	Options
Center Width^a	Spreads the center channel between the front right and left speakers, making it sound wider (higher settings) or narrower (lower settings).	0 to 7 Default: 3
Dimension^a	Adjusts the surround sound balance from front to back, making the sound more distant (minus settings), or more forward (positive settings).	-3 to +3 Default: 0
Panorama^a	Extends the front stereo image to include surround speakers for a 'wraparound' effect.	OFF ON
Effect	Sets the effect level for the currently selected Advanced Surround mode (each mode can be set separately).	10 to 90 ^b

a. Only available with 2ch sources in Dolby Pro Logic II Music mode.

b. For all Advanced Surround modes except **EX. POWER** the default Effect setting is 70. The default setting for **EX. POWER** is 90.

Note

¹ Use with Dolby Pro Logic for a stereo surround effect (stereo field is wider than Standard modes with Dolby Digital sources).

Using the Virtual Surround Back mode (VSB)

Selecting this mode allows you to hear a virtual surround back channel through your surround speakers. For example, you can choose to listen to sources with no surround back channel information (for example, 5.1 encoded material) with emulated 6.1 encoding (**VSB ON**). Sometimes the material may sound better in the 5.1 format for which it was originally encoded. In this case you can simply switch it off (**VSB OFF**).¹

Depending on the input signal and the Listening Mode, the Virtual Surround Back mode may not be effective.

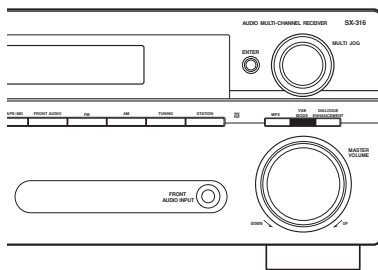

- Press **VSB MODE** (front panel) to select a virtual surround back channel option.

Each press cycles through the options as follows:

- **VSB ON** – Virtual Surround Back is always used (for example, on 5.1 encoded material)
- **VSB OFF** – Virtual Surround Back mode is switched off

Listening in stereo

When you select **STEREO** or **DIRECT**, you will hear the source through just the front left and right speakers.

Dolby Digital and DTS multichannel sources are downmixed to stereo.

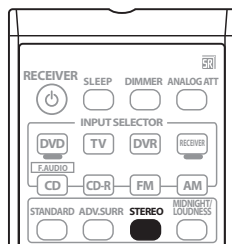

- While listening to a source, press **STEREO** for stereo playback.

Press repeatedly to switch between:

- **STEREO** – The audio is heard with your surround settings and you can still use the Midnight, Loudness, and Tone functions.
- **DIRECT** – Bypass all effects and surround settings so that the audio remains as close to the source audio signal as possible.²
- **AUTO SURR.** – See *Auto playback* on page 19 for more on this.

Note

¹ You can't use the Virtual Surround Back mode with headphones or with the **STEREO** / **DIRECT** mode.

² **DIRECT** switches to **STEREO** when using Midnight, Loudness, Dialog Enhancement, Sound Retriever, or the tone controls.

Bringing the Sound Retriever

When audio data is removed during the compression process, sound quality often suffers from an uneven sound image. The Sound Retriever feature employs new DSP processing that helps bring CD quality sound back to compressed 2-channel audio by increasing dynamic range, pressure and smoothing the sound to recover after compression.

MENU
DIALOGUE
ONE TOUCH COPY

Chapter 5: The System Setup menu

Making receiver settings from the System Setup menu

The following section shows you how to make detailed settings to specify how you're using the receiver and also explains how to fine-tune individual speaker system settings to your liking.

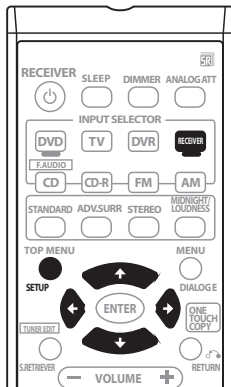

- 1 Press **RECEIVER** on the remote control, then press the **SETUP** button.
- 2 Use **↑/↓** (cursor up/down) to select the setting you want to adjust then press **ENTER**.

- **SP SETUP** allows you to specify the distance and balance of the speakers you've connected:

CH LEVEL — Adjust overall balance of your speaker system.

SP DISTN. — Specify the distance of your speakers from the listening position.

- **OTHER** allows you to make customized settings to reflect how you are using the receiver.

DRC – This setting specifies the amount of dynamic range adjustment to Dolby Digital and DTS movie soundtracks (use this when listening to surround sound at low volumes).

DUALMONO¹ – You can specify how dual mono encoded Dolby Digital soundtracks should be played (dual mono is sometimes used when two languages need to be sent to separate channels).

LFE ATT – Some Dolby Digital and DTS audio sources include ultra-low bass tones. Set the LFE attenuator as necessary to prevent the ultra-low bass tones from distorting the sound from the speakers.

Channel level

Default setting: 0dB (all channels)

- 1 Select **CH LEVEL** from the **SP SETUP** menu.
- 2 Use **←/→** (cursor left/right) to select a setup option.

- **T. TONE M.**– Move the test tone manually from speaker to speaker and adjust individual channel levels.
- **T. TONE A.** – Adjust channel levels as the test tone moves from speaker to speaker automatically.

- 3 Confirm your selected setup option.

The test tones² will start after you press **ENTER**.

Note

¹ This setting works only with dual mono encoded Dolby Digital and DTS soundtracks.

² After the volume increases to the reference level, test tones will be output.

4 Adjust the level of each channel using the \leftarrow/\rightarrow (cursor left/right) buttons.

If you selected **T. TONE M.**, use \uparrow/\downarrow (cursor up/down) to switch speakers.

The **T. TONE A.** setup will output test tones in the following order:

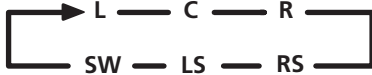

Adjust the level of each speaker as the test tone is emitted.¹

5 When you're finished, press RETURN.



Tip

- You can change the channel levels at any time by using **EFFECT/CH SEL** and **LEVEL +/-** on the remote.

Speaker Distance

1 Select 'SP DISTN.' from the SP SETUP menu.

2 Use \uparrow/\downarrow (cursor up/down) to choose the speaker that you want then set the distance.

Use \leftarrow/\rightarrow (cursor left/right) to adjust the distance of each speaker (in 10 cm increments).

3 When you're finished, press RETURN.

Dynamic Range Control Setup

- Default setting: **OFF**

1 Select **DRC** from the OTHER setup menu.

2 Use \leftarrow/\rightarrow (cursor left/right) to choose the setting that you want.

- OFF** – No dynamic range adjustment (use when listening at higher volume).

- MID** – Mid setting.

- MAX** – Dynamic range is reduced (loud sounds are reduced in volume while quieter sounds are increased).

3 When you're finished, press RETURN.

Dual Mono Setup

- Default setting: **CH1**

1 Select **DUAL MONO** from the OTHER setup menu.

2 Use \leftarrow/\rightarrow (cursor left/right) to choose the setting that you want.

- CH1** – Only channel 1 is played
- CH2** – Only channel 2 is played
- CH1 CH2** – Both channels are played through the front speakers

3 When you're finished, press RETURN.

LFE Attenuator Setup

- Default setting: **ATT 0 dB**

1 Select **LFE ATT** from the OTHER setup menu.

2 Use \leftarrow/\rightarrow (cursor left/right) to choose the setting that you want.

- LFEATT 0** – No limiting (recommended setting)
- LFEATT 10** – 10 dB of limiting
- LFEATT **** – No sound from LFE channel

3 When you're finished, press RETURN.

Note

1 • If you are using a Sound Pressure Level (SPL) meter, take the readings from your main listening position and adjust the level of each speaker to 75 dB SPL (C-weighting/slow reading).

- The subwoofer test tone is output at low volumes. You may need to adjust the level after testing with an actual soundtrack.

Chapter 6:

Using the tuner

Listening to the radio

The following steps show you how to tune in to FM and AM radio broadcasts and memorize the frequency for recall later.

1 Press AM or FM to select the tuner band.

2 Tune to a station.

There are three ways to do this:

- **Automatic tuning** – Press and hold **TUNING +/-** for about a second. Searching automatically stops at the next station.
- **Manual tuning** – To change the frequency one step at a time, press **TUNING +/-**.
- **High speed tuning** – Press and hold **TUNING +/-** continuously.

If the signal is weak, press the **MPX** button to switch the receiver into mono reception mode.

Saving station presets

This receiver can memorize up to 30 stations, stored in three banks of 10 stations each.¹

1 Tune to a station you want to memorize.

2 Press (SHIFT +) TUNER EDIT to select 'ST. MEMORY'.

3 Press CLASS to select one of the three classes then press STATION +/- to select the station preset you want.

You can also use the **MULTI JOG** dial (front panel) to select station presets.

4 Press ENTER to store the station.

Naming station presets

You can name your station presets for easy recall.

1 Choose the preset you want to name.

See *Listening to station presets* below.

2 Press (SHIFT +) TUNER EDIT to select 'ST. NAME'.

A cursor appears at the first character position.

3 Input the name you want then press ENTER.

- Use the **MULTI JOG** dial (front panel) or the **STATION +/-** buttons (remote) to select characters, and **ENTER** to confirm. If no character is input, a space is input.



Tip

- Once you have named a station preset, you can press **DISPLAY** when listening to a station to switch the display between the name and the frequency.

Listening to station presets

You will need to have some presets stored to do this. See *Saving station presets* above if you haven't done this already.

1 Press AM or FM to select the tuner.

2 Press CLASS to select the class in which the station is stored.

Press repeatedly to cycle through classes **A**, **B** and **C**.

3 Press STATION +/- to select the station preset you want.

Note

¹ When saving an FM frequency, the **MPX** setting is also stored.

7
EDIT

ween
do this

Chapter 7: Additional information

Troubleshooting

Incorrect operations are often mistaken for trouble and malfunctions. If you think that there is something wrong with this component, check the points below. Take a look at the other components and electrical appliances being used, because sometimes the problem may lie there. If the trouble isn't sorted out even after going through the checks below, ask your nearest Pioneer authorized independent service company to carry out repair work.

- If the unit does not operate normally due to external effects such as static electricity, disconnect the power plug from the outlet and insert again to return to normal operating conditions.

Problem	Remedy
The power does not turn on.	<ul style="list-style-type: none"> • Connect the power plug to the wall outlet. • Disconnect the power plug from the outlet, and insert again. • Make sure there are no loose strands of speaker wire touching the rear panel. This could cause the receiver to shut off automatically. • If the power shuts off automatically, take the unit to your nearest Pioneer authorized service center or your dealer for servicing.
No sound is output when a function is selected.	<ul style="list-style-type: none"> • Make sure the component is connected correctly (refer to <i>Connecting up</i> on page 7). • Press MUTE on the remote control to turn muting off. • Adjust the MASTER VOLUME.
Considerable noise in radio broadcasts.	<ul style="list-style-type: none"> • Tune in the correct frequency. • Connect the antenna and adjust the direction and position for best reception (refer to page 9). • Route any loose cables away from the antenna terminals and wires. • Fully extend the FM wire antenna, position for best reception, and secure to a wall. • Connect an outdoor FM antenna (refer to page 10). • Connect an additional internal or external AM antenna (refer to page 10). • Turn off the equipment causing the noise or move it away from the receiver. • Move antennas farther away from equipment causing the noise.
Broadcast stations cannot be selected automatically.	<ul style="list-style-type: none"> • Connect an outdoor antenna (refer to page 10).

Problem	Remedy
No sound from surround or center speakers.	<ul style="list-style-type: none"> • Connect the speakers properly. • Refer to <i>Channel level</i> on page 23 to check the speaker levels.
No sound from subwoofer.	<ul style="list-style-type: none"> • The Dolby Digital or DTS source you are listening to may not have an LFE channel. • Switch the <i>LFE Attenuator Setup</i> on page 24 to LFEATT 0 or LFEATT 10.
Noise during playback of a cassette deck.	<ul style="list-style-type: none"> • Move the cassette deck further from your receiver, until the noise disappears.
No sound is output or a noise is output when software with DTS is played back.	<ul style="list-style-type: none"> • Set the digital volume level of the player to full, or to the neutral position.
During a playback search, noise is output from a DTS compatible CD player.	<ul style="list-style-type: none"> • This is not a malfunction, but be sure to turn the volume down to prevent the output of loud noise from your speakers.
Can't operate the remote control.	<ul style="list-style-type: none"> • Replace the batteries (refer to page 5). • Operate within 7 m, 30° of the remote sensor on the front panel (refer to page 5). • Remove the obstacle or operate from another position. • Avoid exposing the remote sensor on the front panel to direct light.
The display is dark or off.	<ul style="list-style-type: none"> • Press DIMMER on the remote control repeatedly to return to the default.

Resetting the main unit

Use this procedure to reset all the receiver's settings to the factory default. Use the front panel controls to do this.

- 1 Switch the receiver into standby.**
- 2 While holding down the TONE button, press and hold the \odot STANDBY/ON button for about three seconds.**
- 3 When you see RESET? appear in the display, press the ENTER button.**
OK? shows in the display.
- 4 Press SETUP to confirm.**
OK appears in the display to indicate that the receiver has been reset to the factory default setting.

Cleaning the unit

- Use a polishing cloth or dry cloth to wipe off dust and dirt.
- When the surface is dirty, wipe with a soft cloth dipped in some neutral cleanser diluted five or six times with water, and wrung out well, and then wipe again with a dry cloth. Do not use furniture wax or cleansers.
- Never use thinners, benzene, insecticide sprays or other chemicals on or near this unit, since these will corrode the surface.

Specifications

Amplifier section

Continuous Power Output (stereo)
 Front 100 W (DIN 1 kHz, THD, 1.0 %, 8 Ω)

Power Output (surround)
 Front
 100 W per channel (1 kHz, 1.0 % THD, 8 Ω)
 Center 100 W (1 kHz, 1.0 % THD, 8 Ω)
 Surround 100 W per channel
 (1 kHz, 1.0 % THD, 8 Ω)
 Subwoofer 100 W (100 Hz, 1.0 % THD, 8 Ω)

Maximum Power Output
 Front
 130 W per channel (1 kHz, 10 % THD, 8 Ω)
 Center 130 W (1 kHz, 10 % THD, 8 Ω)
 Surround 130 W per channel
 (1 kHz, 10 % THD, 8 Ω)
 Subwoofer 130 W (100 Hz, 10 % THD, 8 Ω)

FM Tuner Section

Frequency Range 87.5 MHz to 108 MHz
 Antenna Input 75 Ω unbalanced

AM Tuner Section

Frequency Range
 9 kHz step 531 kHz to 1 602 kHz
 10 kHz step 530 kHz to 1 700 kHz
 Antenna Loop antenna

Miscellaneous

Power requirements
 AC 110 V/ 120 V to 127 V/220 V / 240V,
 50 Hz / 60 Hz
 Power consumption 320 W
 In standby 0.5 W (AC 220V/50 Hz)
 Dimensions
 420 mm (W) x 158 mm (H) x 348 mm (D)
 Weight (without package) 8.4 kg

Furnished Parts

AM loop antenna	1
FM wire antenna	1
AA size IEC R6 dry cell batteries	2
Remote control	1
Power cords	3
J-shaped plug	1
These operating instructions	

Note

- Specifications and the design are subject to possible modifications without notice, due to improvements.

Published by Pioneer Corporation.
 Copyright ©2006 Pioneer Corporation.
 All rights reserved.

Published by Pioneer Corporation.
Copyright © 2006 Pioneer Corporation.
All rights reserved.

PIONEER CORPORATION

4-1, Meguro 1-Chome, Meguro-ku, Tokyo 153-8654, Japan

PIONEER ELECTRONICS (USA) INC.

P.O. BOX 1540, Long Beach, California 90810-1540, U.S.A. TEL: (800) 421-1404

PIONEER ELECTRONICS OF CANADA, INC.

300 Allstate Parkway, Markham, Ontario L3R OP2, Canada TEL: 1-877-283-5901

PIONEER EUROPE NV

Haven 1087, Keetberglaan 1, B-9120 Melsele, Belgium TEL: 03/570.05.11

PIONEER ELECTRONICS ASIACENTRE PTE. LTD.

253 Alexandra Road, #04-01, Singapore 159936 TEL: 65-6472-7555

PIONEER ELECTRONICS AUSTRALIA PTY. LTD.

178-184 Boundary Road, Braeside, Victoria 3195, Australia, TEL: (03) 9586-6300

PIONEER ELECTRONICS DE MEXICO S.A. DE C.V.

Blvd.Manuel Avila Camacho 138 10 piso Col.Lomas de Chapultepec, Mexico,D.F. 11000 TEL: 55-9178-4270

K002_A_En

Free Manuals Download Website

<http://myh66.com>

<http://usermanuals.us>

<http://www.somanuals.com>

<http://www.4manuals.cc>

<http://www.manual-lib.com>

<http://www.404manual.com>

<http://www.luxmanual.com>

<http://aubethermostatmanual.com>

Golf course search by state

<http://golfingnear.com>

Email search by domain

<http://emailbydomain.com>

Auto manuals search

<http://auto.somanuals.com>

TV manuals search

<http://tv.somanuals.com>