

*Pioneer*

**VSX-322-K**

AV Receiver

Discover the benefits of registering your product online at <http://www.pioneer.co.uk> (or <http://www.pioneer.eu>).

Operating Instructions

## IMPORTANT



The lightning flash with arrowhead symbol, within an equilateral triangle, is intended to alert the user to the presence of uninsulated "dangerous voltage" within the product's enclosure that may be of sufficient magnitude to constitute a risk of electric shock to persons.

### CAUTION

RISK OF ELECTRIC SHOCK  
DO NOT OPEN

**CAUTION:**  
TO PREVENT THE RISK OF ELECTRIC SHOCK, DO NOT REMOVE COVER (OR BACK). NO USER-SERVICEABLE PARTS INSIDE. REFER SERVICING TO QUALIFIED SERVICE PERSONNEL.



The exclamation point within an equilateral triangle is intended to alert the user to the presence of important operating and maintenance (servicing) instructions in the literature accompanying the appliance.

D3-4-2-1-1\_A1\_En

This product is for general household purposes. Any failure due to use for other than household purposes (such as long-term use for business purposes in a restaurant or use in a car or ship) and which requires repair will be charged for even during the warranty period.

K041\_A1\_En

## WARNING

This equipment is not waterproof. To prevent a fire or shock hazard, do not place any container filled with liquid near this equipment (such as a vase or flower pot) or expose it to dripping, splashing, rain or moisture.

D3-4-2-1-3\_A1\_En

## WARNING

*Before plugging in for the first time, read the following section carefully.*

**The voltage of the available power supply differs according to country or region. Be sure that the power supply voltage of the area where this unit will be used meets the required voltage (e.g., 230 V or 120 V) written on the rear panel.**

D3-4-2-1-4\*\_A1\_En

## WARNING

To prevent a fire hazard, do not place any naked flame sources (such as a lighted candle) on the equipment.

D3-4-2-1-7a\_A1\_En

## Operating Environment

Operating environment temperature and humidity: +5 °C to +35 °C (+41 °F to +95 °F); less than 85 %RH (cooling vents not blocked)  
Do not install this unit in a poorly ventilated area, or in locations exposed to high humidity or direct sunlight (or strong artificial light)

D3-4-2-1-7c\*\_A1\_En

## VENTILATION CAUTION

When installing this unit, make sure to leave space around the unit for ventilation to improve heat radiation (at least 40 cm at top, 20 cm at rear, and 20 cm at each side).

## WARNING

Slots and openings in the cabinet are provided for ventilation to ensure reliable operation of the product, and to protect it from overheating. To prevent fire hazard, the openings should never be blocked or covered with items (such as newspapers, table-cloths, curtains) or by operating the equipment on thick carpet or a bed.

D3-4-2-1-7b\*\_A1\_En

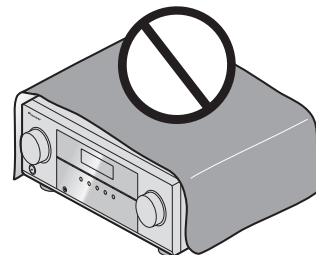

## Information for users on collection and disposal of old equipment and used batteries

(Symbol for equipment)



These symbols on the products, packaging, and/or accompanying documents mean that used electrical and electronic products and batteries should not be mixed with general household waste.

For proper treatment, recovery and recycling of old products and used batteries, please take them to applicable collection points in accordance with your national legislation.

(Symbol examples for batteries)



By disposing of these products and batteries correctly, you will help to save valuable resources and prevent any potential negative effects on human health and the environment which could otherwise arise from inappropriate waste handling.

For more information about collection and recycling of old products and batteries, please contact your local municipality, your waste disposal service or the point of sale where you purchased the items.

**These symbols are only valid in the European Union.**

**For countries outside the European Union:**

If you wish to discard these items, please contact your local authorities or dealer and ask for the correct method of disposal.



Pb

K058a\_A1\_En

If the AC plug of this unit does not match the AC outlet you want to use, the plug must be removed and appropriate one fitted. Replacement and mounting of an AC plug on the power supply cord of this unit should be performed only by qualified service personnel. If connected to an AC outlet, the cut-off plug can cause severe electrical shock. Make sure it is properly disposed of after removal. The equipment should be disconnected by removing the mains plug from the wall socket when left unused for a long period of time (for example, when on vacation).

D3-4-2-1a\_A1\_En

### CAUTION

The **STANDBY/ON** switch on this unit will not completely shut off all power from the AC outlet. Since the power cord serves as the main disconnect device for the unit, you will need to unplug it from the AC outlet to shut down all power. Therefore, make sure the unit has been installed so that the power cord can be easily unplugged from the AC outlet in case of an accident. To avoid fire hazard, the power cord should also be unplugged from the AC outlet when left unused for a long period of time (for example, when on vacation).

D3-4-2-2a\*\_A1\_En

Thank you for buying this Pioneer product. Please read through these operating instructions so you will know how to operate your model properly. After you have finished reading the instructions, put them away in a safe place for future reference.

## Contents

<b>Before you start</b> .....	<b>5</b>
Checking what's in the box .....	5
Installing the receiver .....	5
<b>Flow of settings on the receiver</b> .....	<b>5</b>
<b>01 Controls and displays</b>	
Front panel .....	6
Display .....	7
Remote control .....	8
Loading the batteries .....	9
Operating range of remote control .....	9
<b>02 Connecting your equipment</b>	
Placing the speakers .....	10
Hints on the speaker placement .....	10
Connecting the speakers .....	11
Connect the surround back speakers .....	11
Making cable connections .....	12
HDMI cables .....	12
About HDMI .....	12
Analog audio cables .....	13
Digital audio cables .....	13
Video cables .....	13
About video outputs connection .....	13
Connecting a TV and playback components .....	14
Connecting using HDMI .....	14
Connecting your component with no HDMI terminal .....	14
Connecting a satellite receiver or other digital set-top box .....	15
Connecting other audio components .....	15
Connecting antennas .....	15
Using external antennas .....	16
Plugging in the receiver .....	16

### 03 Basic playback

Canceling the demo display .....	17
Playing a source .....	17
Selecting the audio input signal .....	17
Listening to the radio .....	18
Improving FM sound .....	18
Saving station presets .....	19
Listening to station presets .....	19
Naming preset stations .....	19
An introduction to RDS .....	19
Searching for RDS programs .....	20
Displaying RDS information .....	20
Making an audio recording .....	20

### 04 Listening to your system

Choosing the listening mode .....	21
Auto playback .....	21
Listening in surround sound .....	21
Using the Advanced surround .....	22
Using Stream Direct .....	22
Using the Sound Retriever .....	22
Better sound using Phase Control .....	22
Using surround back channel processing .....	23
Setting the Up Mix function .....	23
Setting the Audio options .....	23

### 05 The System Setup menu

Using the System Setup menu .....	25
The Speaker Setup menu .....	25
Speaker Setting .....	25
X.Over .....	26
Channel Level .....	26
Speaker Distance .....	26
The Auto Power Down menu .....	26
The FL Demo Mode menu .....	26

### 06 ARC (Audio Return Channel) function

ARC Setup .....	27
Before starting ARC operation .....	27

### 07 Additional information

Troubleshooting .....	28
General .....	28
HDMI .....	29
Important information regarding the HDMI connection .....	29
Resetting the main unit .....	29
Cleaning the unit .....	29
Specifications .....	30

# Before you start

## Checking what's in the box

Please check that you've received the following supplied accessories:

- Remote control
- AAA size IEC R03 dry cell batteries (to confirm system operation) x2
- AM loop antenna
- FM wire antenna
- Power cord
- Warranty card
- Quick start guide
- These operating instructions (CD-ROM)

## Installing the receiver

- When installing this unit, make sure to put it on a level and stable surface.

Don't install it on the following places:

- on a color TV (the screen may distort)
- near a cassette deck (or close to a device that gives off a magnetic field). This may interfere with the sound.
- in direct sunlight
- in damp or wet areas
- in extremely hot or cold areas
- in places where there is vibration or other movement
- in places that are very dusty
- in places that have hot fumes or oils (such as a kitchen)

# Flow of settings on the receiver

The unit is a full-fledged AV receiver equipped with an abundance of functions and terminals. It can be used easily after following the procedure below to make the connections and settings.

*The colors of the steps indicate the following:*

## Required setting item

## Setting to be made as necessary

### 1 Connecting the speakers

Where you place the speakers will have a big effect on the sound.

- Placing the speakers (page 10)
- Connecting the speakers (page 11)



### 2 Connecting the components

For surround sound, you'll want to hook up using a digital connection from the Blu-ray Disc/DVD player to the receiver.

- About video outputs connection (page 13)
- Connecting a TV and playback components (page 14)
- Connecting antennas (page 15)
- Plugging in the receiver (page 16)



### 3 Power On

Make sure you've set the video input on your TV to this receiver. Check the manual that came with the TV if you don't know how to do this.



### 4 Specify the size and number of speakers you've connected

- Speaker Setting (page 25)



### 5 The FL Demo Mode menu (page 26)

*(When you don't want the demo display to show on the front panel display.)*

### Using the Audio Return Channel function (page 27)

*(When the connected TV supports the HDMI Audio Return Channel function.)*



### 6 Playing a source (page 17)

- Selecting the audio input signal (page 17)
- Choosing the listening mode (page 21)



### 7 Adjusting the sound as desired

- Using the Sound Retriever (page 22)
- Better sound using Phase Control (page 22)
- Using surround back channel processing (page 23)
- Setting the Up Mix function (page 23)
- Setting the Audio options (page 23)
- The Speaker Setup menu (page 25)

## Chapter 1: Controls and displays

### Front panel

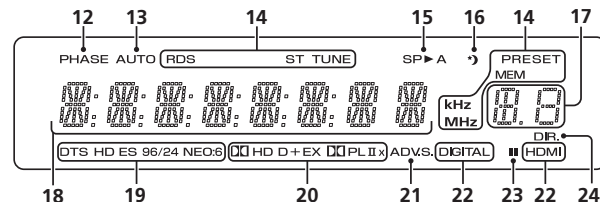
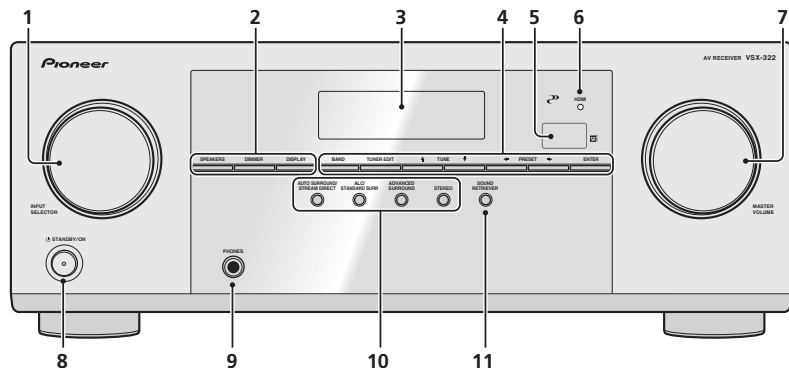

#### 1 INPUT SELECTOR dial

Selects an input source (page 17).

#### 2 Receiver control buttons

**SPEAKERS** – Use to change the speaker system on or off. When the **SP OFF** is selected, no sound is output from the speakers connected to this receiver.

**DIMMER** – Dims or brightens the display. The brightness can be controlled in four steps.

**DISPLAY** – Switches the display of this unit. The listening mode, sound volume or input name can be checked by selecting an input source.

#### 3 Character display

See *Display* on page 7.

#### 4 Tuner control buttons

**BAND** – Switches between AM, FM ST (stereo) and FM MONO radio bands (page 18).

**TUNER EDIT** – Use with **TUNE**  $\uparrow/\downarrow$ , **PRESET**  $\leftarrow/\rightarrow$  and **ENTER** to memorize and name stations for recall (page 18).

**TUNE**  $\uparrow/\downarrow$  – Used to find radio frequencies (page 18).

**PRESET**  $\leftarrow/\rightarrow$  – Use to select preset radio stations (page 19).

#### 5 Remote sensor

Receives the signals from the remote control (see *Operating range of remote control* on page 9).

#### 6 HDMI indicator

Blinks when connecting an HDMI-equipped component; lights when the component is connected (page 14).

#### 7 MASTER VOLUME dial

#### 8 $\odot$ STANDBY/ON

#### 9 PHONES jack

Use to connect headphones. When the headphones are connected, there is no sound output from the speakers. The listening mode when the sound is heard from the headphones can be selected only from **PHONES SURR**, **STEREO** or **STEREO ALC** mode.

#### 10 Listening mode buttons

**AUTO SURROUND/STREAM DIRECT** – Switches between Auto surround mode (page 21) and Stream Direct playback (page 21).

**ALC/STANDARD SURR** – Press for standard decoding and to switch between the modes of  $\square\square$  Pro Logic II,  $\square\square$  Pro Logic IIx and NEO:6, and the Auto level control stereo mode (page 21).

**ADVANCED SURROUND** – Switches between the various surround modes (page 22).

**STEREO** – Press to select stereo playback (page 21).

## 11 SOUND RETRIEVER

Press to restore CD quality sound to compressed audio sources (page 22).

## Display

### 12 PHASE

Lights when the Phase Control is switched on (page 22).

### 13 AUTO

Lights when the Auto Surround feature is switched on (page 21).

### 14 Tuner indicators

**RDS** – Lights when an RDS broadcast is received (page 19).

**ST** – Lights when a stereo FM broadcast is being received in auto stereo mode (page 18).

**TUNE** – Lights when a normal broadcast channel.

**PRESET** – Shows when a preset radio station is registered or called.

**MEM** – Blinks when a radio station is registered.

**kHz/MHz** – Lights when the character display is showing the currently received AM/FM broadcast frequency.

### 15 Speaker indicators

Shows if the speaker system is on or not (page 6).

**SP▶A** means the speakers are switched on.

**SP▶** means the speakers are switched off.

### 16 Sleep timer indicator

Lights when the receiver is in sleep mode (page 8).

### 17 PRESET information or input signal indicator

Shows the preset number of the tuner or the input signal type, etc.

### 18 Character display

Displays various system information.

### 19 DTS indicators

**DTS** – Lights when a source with DTS encoded audio signals is detected.

**HD** – Lights when a source with DTS-EXPRESS or DTS-HD encoded audio signals is detected.

**ES** – Lights to indicate DTS-ES decoding.

**96/24** – Lights when a source with DTS 96/24 encoded audio signals is detected.

**NEO:6** – When one of the NEO:6 modes of the receiver is on, this lights to indicate NEO:6 processing (page 21).

## 20 Dolby Digital indicators

**DD** – Lights when a Dolby Digital encoded signal is detected.

**DD+** – Lights when a source with Dolby Digital Plus encoded audio signals is detected.

**DDHD** – Lights when a source with Dolby TrueHD encoded audio signals is detected.

**EX** – Lights to indicate Dolby Digital EX decoding.

**DDPLI(x)** – Lights to indicate **DD** Pro Logic II/**DD** Pro Logic IIx decoding (see *Listening in surround sound* on page 21 for more on this).

## 21 ADV.S.

Lights when one of the Advanced Surround modes has been selected (see *Using the Advanced surround* on page 22 for more on this).

## 22 SIGNAL SELECT indicators

**DIGITAL** – Lights when a digital audio signal is selected. Blinks when a digital audio signal is selected and selected audio input is not provided.

**HDMI** – Lights when an HDMI signal is selected. Blinks when an HDMI signal is selected and selected HDMI input is not provided.

## 23 Up Mix/DIMMER indicator

Lights when the Up Mix function is set to **ON** (page 23). Also, lights when DIMMER is set to off.

## 24 DIR.

Lights when the **DIRECT** or **PURE DIRECT** mode is switched on (page 22).

## Remote control

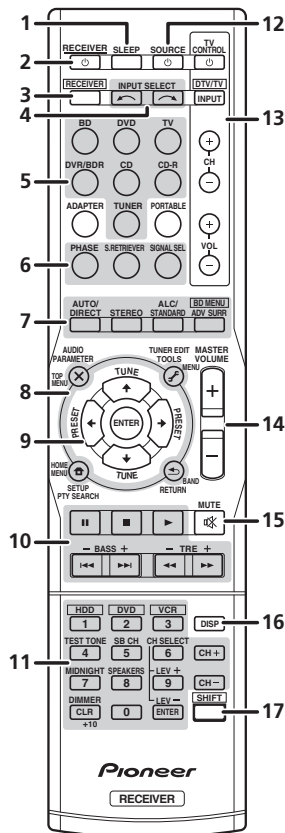

As for operating other devices, the remote control codes for the Pioneer products are preset. The settings cannot be changed.

**1 SLEEP**

Press to change the amount of time before the receiver switches into standby (**30 min – 60 min – 90 min – Off**). You can check the remaining sleep time at any time by pressing **SLEEP** once.

**2 RECEIVER**

Switches the receiver between standby and on.

**3 RECEIVER**

Switches the remote to control the receiver (used to select the white commands above the number buttons (**MIDNIGHT**, etc)). Also use this button to set up surround sound (page 25) or Audio parameters (page 23).

**4 INPUT SELECT**

Use to select the input source (page 17).

**5 Input function buttons**

Use to select the input source to this receiver (page 17). This will enable you to control other Pioneer components with the remote control.

- **ADAPTER, PORTABLE** button is not used with this receiver.

**6 Receiver control buttons**

**PHASE** – Press to switch on/off Phase Control (page 22).

**S.RETRIEVER** – Press to restore CD quality sound to compressed audio sources (page 22).

**SIGNAL SEL** – Press to select the audio input signal of the component to play back (page 17).

**7 Listening mode buttons**

**AUTO/DIRECT** – Switches between Auto surround mode (page 21) and Stream Direct playback (page 22).

**STEREO** – Press to select stereo playback (page 21).

**ALC/STANDARD** – Press for standard decoding and to switch between the modes of **PRO** Pro Logic II, **PRO** Pro Logic IIx and NEO:6, and the Auto level control stereo mode (page 21).

**ADV SURR** – Switches between the various surround modes (page 22).

Press **BD** first to access:

**BD MENU\*** – Displays the disc menu of Blu-ray Discs.

**8 System Setup and component control buttons**

The following button controls can be accessed after you have selected the corresponding input function button (**BD, DVD, etc.**).

Press **RECEIVER** first to access:

**AUDIO PARAMETER** – Use to access the Audio options (page 23).

**SETUP** – Press to access the System Setup menu (page 25).

**RETURN** – Confirm and exit the current menu screen.

Press **BD, DVD** or **DVR/BDR** first to access:

**TOP MENU** – Displays the disc 'top' menu of a Blu-ray Disc/DVD.

**HOME MENU** – Displays the HOME MENU screen.

**RETURN** – Confirm and exit the current menu screen.

**MENU** – Displays the TOOLS menu of Blu-ray Disc player.

Press **TUNER** first to access:

**TUNER EDIT** – Memorizes stations for recall (page 18), also used to change the name (page 19).

**BAND** – Switches between AM, FM ST (stereo) and FM MONO radio bands (page 18).

**PTY SEARCH** – Use to search for RDS program types (page 19).

**9 TUNE, PRESET, ENTER**

Use the arrow buttons when setting up your surround sound system (page 25). Also used to control Blu-ray Disc/DVD menus/options.

Use **TUNE**  $\uparrow/\downarrow$  can be used to find radio frequencies and **PRESET**  $\leftarrow/\rightarrow$  can be used to select preset radio stations (page 19).

**10 Component control buttons**

The main buttons (**▶, ■**, etc.) are used to control a component after you have selected it using the input function buttons.

The controls above these buttons can be accessed after you have selected the corresponding input function button (**BD, DVD, DVR/BDR** and **CD**). These buttons also function as described below.



Press **RECEIVER** first to access:

**BASS +/-, TRE +/-** – Use to adjust Bass or Treble.

- These controls are disabled when the listening mode is set to **DIRECT** or **PURE DIRECT**.
- When the front speaker is set at **SMALL** in the Speaker Setting and the **X.OVER** is set above 150 Hz, the subwoofer channel level will be adjusted by pressing **BASS +/-** (page 26).

### 11 Number buttons and other component controls

Use the number buttons to directly select a radio frequency (page 18) or the tracks on a CD, etc. There are other buttons that can be accessed after **RECEIVER** is pressed. (For example **MIDNIGHT**, etc.)

**HDD\*, DVD\*, VCR\*** – These buttons switch between the hard disk, DVD and VCR controls for HDD/DVD/VCR recorders.

**SB CH** – Press to select **ON**, **AUTO** or **OFF** the surround back channel (page 23).

**CH SELECT** – Press repeatedly to select a channel, then use **LEV +/-** to adjust the level (page 26).

**LEV +/-** – Use to adjust the channel level.

**MIDNIGHT** – Switches to Midnight or Loudness listening (page 23).

**SPEAKERS** – Use to change the speaker system on or off. When the **SP OFF** is selected, no sound is output from the speakers connected to this receiver.

**DIMMER** – Dims or brightens the display. The brightness can be controlled in four steps.

### 12 SOURCE

Turns on or off the power of the Pioneer DVD/DVR units when **BD**, **DVD**, **DVR/BDR** or **CD** is selected using the input function buttons.

### 13 TV CONTROL buttons

These buttons can control only be used with Pioneer TVs.

**⏻** – Use to turn on/off the power of the TV.

**INPUT** – Use to select the TV input signal.

**CH +/-** – Use to select channels.

**VOL +/-** – Use to adjust the volume on your TV.

**DTV/TV\*** – Switches between the DTV and analog TV input modes for Pioneer TVs.

### 14 MASTER VOLUME +/-

Use to set the listening volume.

### 15 MUTE

Mutes/unmutes the sound.

### 16 DISP

Switches the display of this unit. The listening mode, sound volume or input name can be checked by selecting an input source.

### 17 SHIFT

Press to access the 'boxed' commands (above the buttons) on the remote. These buttons are marked with an asterisk (\*) in this section.

## Loading the batteries

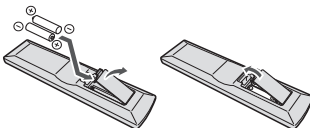

The batteries included with the unit are to check initial operations; they may not last over a long period. We recommend using alkaline batteries that have a longer life.

### ⚠ CAUTION

- Incorrect use of batteries may result in such hazards as leakage and bursting. Observe the following precautions:
  - Never use new and old batteries together.
  - Insert the plus and minus sides of the batteries properly according to the marks in the battery case.
  - Batteries with the same shape may have different voltages. Do not use different batteries together.
  - When disposing of used batteries, please comply with governmental regulations or environmental public institution's rules that apply in your country or area.
  - Do not use or store batteries in direct sunlight or other excessively hot place, such as inside a car or near a heater. This can cause batteries to leak, overheat, explode or catch fire. It can also reduce the life or performance of batteries.

## WARNING

Store the batteries out of the reach of children and infants. If accidentally swallowed, contact a doctor immediately.

## Operating range of remote control

The remote control may not work properly if:

- There are obstacles between the remote control and the receiver's remote sensor.
- Direct sunlight or fluorescent light is shining onto the remote sensor.
- The receiver is located near a device that is emitting infrared rays.
- The receiver is operated simultaneously with another infrared remote control unit.

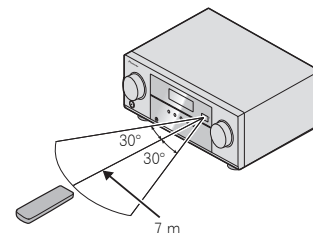

## Chapter 2:

## Connecting your equipment

## Placing the speakers

By connecting the left and right front speakers (**L/R**), the center speaker (**C**), the left and right surround speakers (**SL/SR**), and the subwoofer (**SW**), a 5.1 ch surround system can be enjoyed. Further, by using an external amplifier, you can connect the left and right surround back speakers (**SBL/SBR**) to boost your system up to a 7.1 ch surround system.

- You can also connect one surround back speaker (**SB**) and enjoy a 6.1 ch surround system.

To achieve the best possible surround sound, install your speakers as shown below.

5.1 channel surround system:

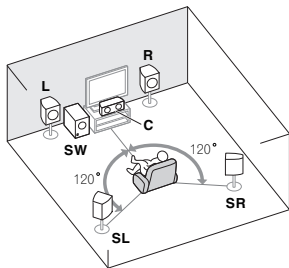
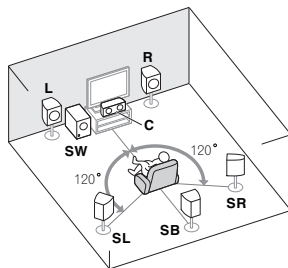
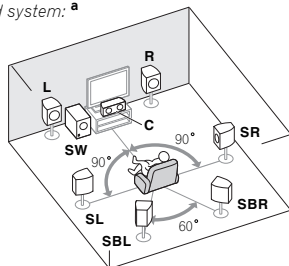
6.1 channel surround system: <sup>a</sup>7.1 channel surround system: <sup>a</sup>

- a. This layout is available only when the additional amplifier is connected to the unit and the surround back speakers are connected to the amplifier. For details, see *Connect the surround back speakers* on page 11.

## Hints on the speaker placement

Where you put your speakers in the room has a big effect on the quality of the sound. The following guidelines should help you to get the best sound from your system.

- The subwoofer can be placed on the floor. Ideally, the other speakers should be at about ear-level when you're listening to them. Putting the speakers on the floor (except the subwoofer), or mounting them very high on a wall is not recommended.
- For the best stereo effect, place the front speakers 2 m to 3 m apart, at equal distance from the TV.
- If you're going to place speakers around your CRT TV, use shielded speakers or place the speakers at a sufficient distance from your CRT TV.
- If you're using a center speaker, place the front speakers at a wider angle. If not, place them at a narrower angle.
- Place the center speaker above or below the TV so that the sound of the center channel is localized at the TV screen. Also, make sure the center speaker does not cross the line formed by the leading edge of the front left and right speakers.
- It is best to angle the speakers towards the listening position. The angle depends on the size of the room. Use less of an angle for bigger rooms.
- Surround and surround back speakers should be positioned 60 cm to 90 cm higher than your ears and tilted slight downward. Make sure the speakers don't face each other. For DVD-Audio, the speakers should be more directly behind the listener than for home theater playback.
- If the surround speakers cannot be set directly to the side of the listening position with a 7.1-channel system, the surround effect can be enhanced by turning off the Up Mix function (see *Setting the Up Mix function* on page 23).
- Try not to place the surround speakers farther away from the listening position than the front and center speakers. Doing so can weaken the surround sound effect.

## ⚠ CAUTION

- Make sure that all speakers are securely installed. This not only improves sound quality, but also reduces the risk of damage or injury resulting from speakers being knocked over or falling in the event of external shocks such as earthquakes.

## 🔑 Important

- To connect the surround back speakers, an additional amplifier is required. Connect the additional amplifier to the **SURR BACK PRE OUT** outputs of this unit and connect the surround back speakers to the additional amplifier (see *Connect the surround back speakers* on page 11).

## Connecting the speakers

The receiver will work with just two stereo speakers (the front speakers in the diagram) but using at least three speakers is recommended, and a complete setup is best for surround sound.

Make sure you connect the speaker on the right to the right (R) terminal and the speaker on the left to the left (L) terminal. Also make sure the positive (+) and negative (+/-) terminals on the receiver match those on the speakers.

You can use speakers with a nominal impedance between 6 Ω and 16 Ω.

Be sure to complete all connections before connecting this unit to the AC power source.

### Bare wire connections

Front speaker terminals:

- 1 Twist exposed wire strands together.
- 2 Loosen terminal and insert exposed wire.
- 3 Tighten terminal.

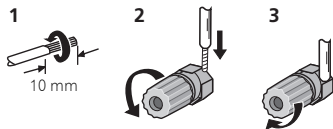

Center and surround speaker terminals:

- 1 Twist exposed wire strands together.
- 2 Push open the tabs and insert exposed wire.
- 3 Release the tabs.

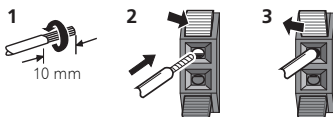

### CAUTION

- These speaker terminals carry **HAZARDOUS LIVE voltage**. To prevent the risk of electric shock when connecting or disconnecting the speaker cables, disconnect the power cord before touching any uninsulated parts.
- Make sure that all the bare speaker wire is twisted together and inserted fully into the speaker terminal. If any of the bare speaker wire touches the back panel it may cause the power to cut off as a safety measure.

### Connect the surround back speakers

Connect the **SURR BACK PRE OUT** outputs of the unit and additional amplifier to add a surround back speaker.

- You can use the additional amplifier on the surround back channel pre-outs for a single speaker as well. In this case plug the amplifier into the left (L (Single)) terminal only.

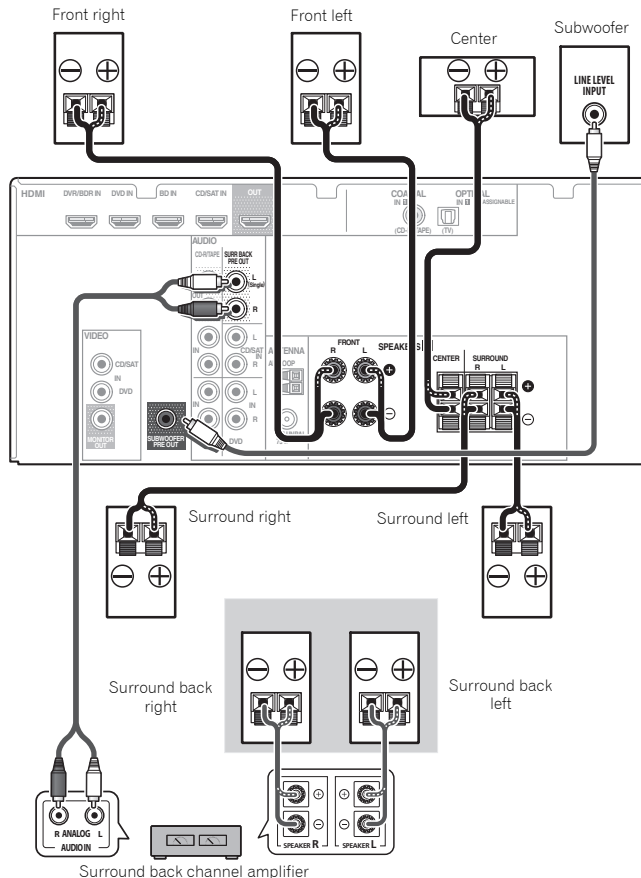

## Making cable connections

Make sure not to bend the cables over the top of this unit. If this happens, the magnetic field produced by the transformers in this unit may cause a humming noise from the speakers.

### Important

- Before making or changing connections, switch off the power and disconnect the power cord from the AC outlet.
- Before unplugging the power cord, switch the power into standby.

## HDMI cables

Both video and sound signals can be transmitted simultaneously with one cable. If connecting the player and the TV via this receiver, for both connections, use HDMI cables.

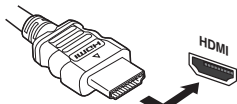

Be careful to connect the terminal in the proper direction.

### Note

- Set the HDMI parameter in *Setting the Audio options* on page 23 to **THRU** (THROUGH) and set the input signal in *Selecting the audio input signal* on page 17 to **HDMI**, if you want to hear HDMI audio output from your TV (no sound will be heard from this receiver).
- If the video signal does not appear on your TV, try adjusting the resolution settings on your component or display. Note that some components (such as video game units) have resolutions that may not be displayed. In this case, use a (analog) composite connection.
- When the video signal from the HDMI is 480i, 480p, 576i or 576p, Multi Ch PCM sound and HD sound cannot be received.

## About HDMI

The HDMI connection transfers uncompressed digital video, as well as almost every kind of digital audio that the connected component is compatible with, including DVD-Video, DVD-Audio, Dolby Digital Plus, Dolby TrueHD, DTS-HD Master Audio (see below for limitations), Video CD/Super VCD and CD.

This receiver incorporates High-Definition Multimedia Interface (HDMI<sup>®</sup>) technology.

This receiver supports the functions described below through HDMI connections.

- Digital transfer of uncompressed video (contents protected by HDCP (1080p/24, 1080p/60, etc.))
- 3D signal transfer
- Deep Color signal transfer
- x.v.Color signal transfer
- Audio Return Channel (see *ARC (Audio Return Channel) function* on page 27)
- Input of multi-channel linear PCM digital audio signals (192 kHz or less) for up to 8 channels
- Input of the following digital audio formats:
  - Dolby Digital, Dolby Digital Plus, DTS, High bitrate audio (Dolby TrueHD, DTS-HD Master Audio), DVD-Audio, CD, Video CD, Super VCD.

### Note

- Use a High Speed HDMI<sup>®</sup> cable. If HDMI cable other than a High Speed HDMI<sup>®</sup> cable is used, it may not work properly.
- When an HDMI cable with a built-in equalizer is connected, it may not operate properly.
- 3D, Deep Color, x.v.Color signal transfer and Audio Return Channel are only possible when connected to a compatible component.
- HDMI format digital audio transmissions require a longer time to be recognized. Due to this, interruption in the audio may occur when switching between audio formats or beginning playback.
- Turning on/off the device connected to this unit's HDMI OUT terminal during playback, or disconnecting/connecting the HDMI cable during playback, may cause noise or interrupted audio.

*The terms HDMI and HDMI High-Definition Multimedia Interface, and the HDMI logo are trademarks or registered trademarks of HDMI Licensing, LLC in the United States and other countries.*

*"x.v.Color" and x.v.Color are trademarks of Sony Corporation.*

## Analog audio cables

Use stereo RCA phono cables to connect analog audio components. These cables are typically red and white, and you should connect the red plugs to R (right) terminals and white plugs to L (left) terminals.

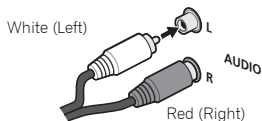

## Digital audio cables

Commercially available coaxial digital audio cables or optical cables should be used to connect digital components to this receiver.

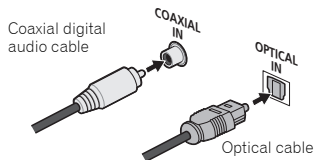

### Note

- When connecting optical cables, be careful when inserting the plug not to damage the shutter protecting the optical socket.
- When storing optical cable, coil loosely. The cable may be damaged if bent around sharp corners.
- You can also use a standard RCA video cable for coaxial digital connections.

## Video cables

### Standard RCA video cables

These cables are the most common type of video connection and are used to connect to the composite video terminals. The yellow plugs distinguish them from cables for audio.

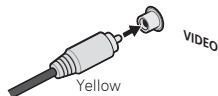

## About video outputs connection

This receiver is not loaded with a video converter. When you use HDMI cables for connecting to the input device, the same cables should be used for connecting to the TV. The signals input from the analog (composite) video inputs of this unit will not be output from the **HDMI OUT**.

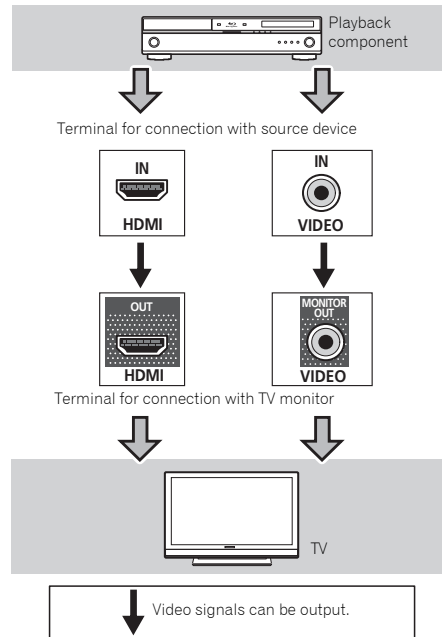

## Connecting a TV and playback components

### Connecting using HDMI

If you have an HDMI or DVI (with HDCP) equipped component (Blu-ray Disc player, etc.), you can connect it to this receiver using a commercially available HDMI cable.

- The following connection/setting is required to listen to the sound of the TV over this receiver.
  - If the TV does not support the HDMI Audio Return Channel function, connect the receiver and TV with audio cables (as shown).
  - If the TV supports the HDMI Audio Return Channel function, the sound of the TV is input to the receiver via the HDMI terminal, so there is no need to connect an audio cable. In this case, set **ARC** at **HDMI SET** to **ON** (see *ARC Setup* on page 27).

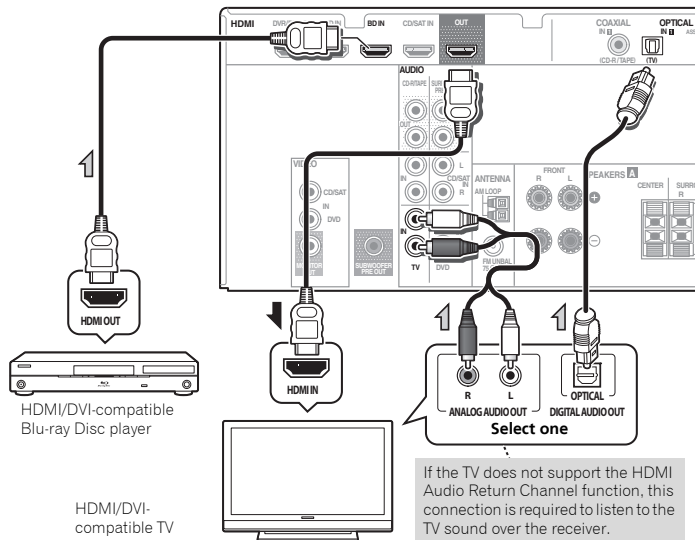

### Connecting your component with no HDMI terminal

This diagram shows connections of a TV and DVD player (or other playback component) with no HDMI terminal to the receiver.

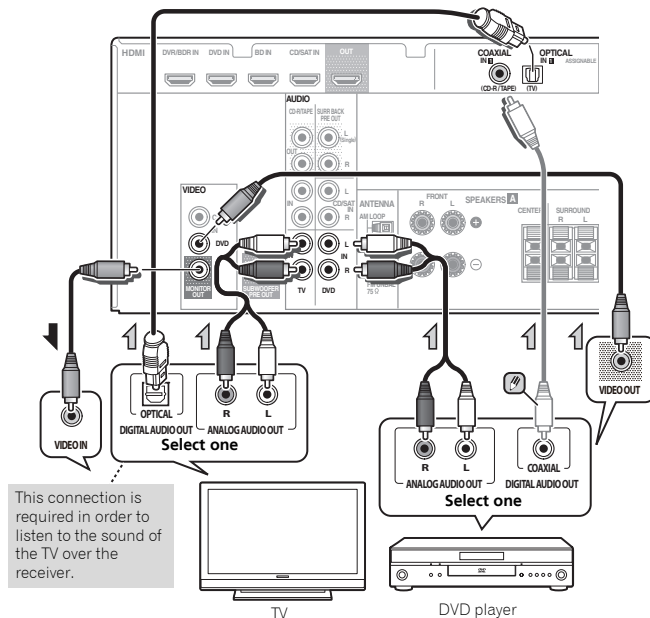

#### Note

- In order to listen to the audio from the DVD player that is connected to this receiver using a coaxial cable, first, switch to the **DVD** input, then press **SIGNAL SEL** to choose the audio signal **C1** (COAXIAL1) (see *Selecting the audio input signal* on page 17).

### Connecting a satellite receiver or other digital set-top box

Satellite and cable receivers, and terrestrial digital TV tuners are all examples of so-called 'set-top boxes'.

- If the set-top box or video component also has an HDMI output, you can connect this too. See *Connecting using HDMI* on page 14 for more on this.

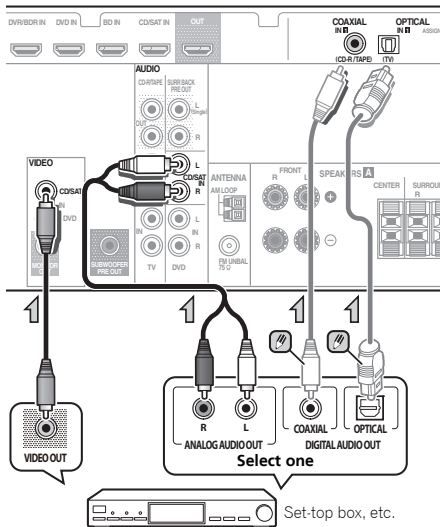

**Note**

- In order to listen to the audio from the source component that is connected to this receiver using a coaxial cable or an optical cable, first, switch to the **CD/SAT**, then press **SIGNAL SEL** to choose the audio signal **C1** (COAXIAL1) or **O1** (OPTICAL1) (see *Selecting the audio input signal* on page 17).

### Connecting other audio components

The number and kind of connections depends on the kind of component you're connecting. Follow the steps below to connect a CD-R, MD, DAT, tape recorder or other audio component.

- Note that you must connect digital components to analog audio jacks if you want to record to/from digital components (like an MD) to/from analog components.

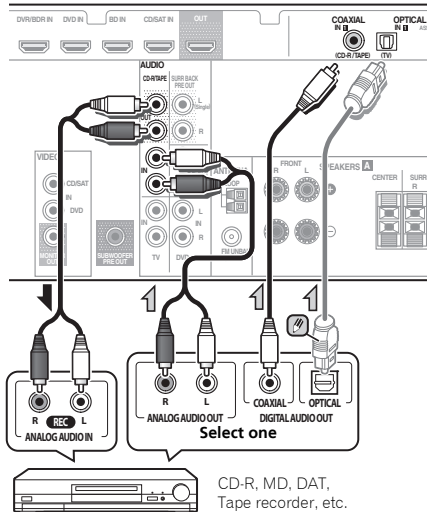

**Note**

- In order to listen to the audio from the CD player that is connected to this receiver using an optical cable, first, switch to the **CD-R** input, then press **SIGNAL SEL** to choose the audio signal **O1** (OPTICAL1) (see *Selecting the audio input signal* on page 17).

### Connecting antennas

Connect the AM loop antenna and the FM wire antenna as shown below. To improve reception and sound quality, connect external antennas (see *Using external antennas* on page 16).

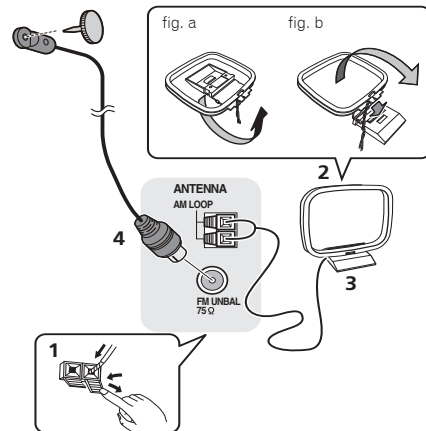

- 1 Push open the tabs, then insert one wire fully into each terminal, then release the tabs to secure the AM antenna wires.
- 2 Fix the AM loop antenna to the attached stand. To fix the stand to the antenna, bend in the direction indicated by the arrow (fig. a) then clip the loop onto the stand (fig. b).
- 3 Place the AM antenna on a flat surface and in a direction giving the best reception.
- 4 Connect the FM wire antenna into the FM antenna socket.

For best results, extend the FM antenna fully and fix to a wall or door frame. Don't drape loosely or leave coiled up.

### Using external antennas

#### To improve FM reception

Use a PAL connector (not supplied) to connect an external FM antenna.

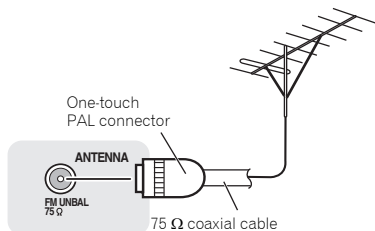

#### To improve AM reception

Connect a 5 m to 6 m length of vinyl-coated wire to the AM antenna terminal without disconnecting the supplied AM loop antenna.

For the best possible reception, suspend horizontally outdoors.

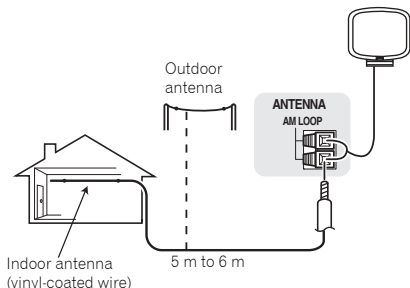

### Plugging in the receiver

Only plug in after you have connected all your components to this receiver, including the speakers.

#### ⚠ CAUTION

- Handle the power cord by the plug part. Do not pull out the plug by tugging the cord, and never touch the power cord when your hands are wet, as this could cause a short circuit or electric shock. Do not place the unit, a piece of furniture, or other object on the power cord or pinch the cord in any other way. Never make a knot in the cord or tie it with other cables. The power cords should be routed so that they are not likely to be stepped on. A damaged power cord can cause a fire or give you an electric shock. Check the power cord once in a while. If you find it damaged, ask your nearest Pioneer authorized independent service company for a replacement.
- Do not use any power cord other than the one supplied with this unit.
- Do not use the supplied power cord for any purpose other than that described below.
- The receiver should be disconnected by removing the mains plug from the wall socket when not in regular use, e.g., when on vacation.

#### 📌 Note

- After this receiver is connected to an AC outlet, a 2 second to 10 second HDMI initialization process begins. You cannot carry out any operations during this process. The **HDMI** indicator in the front panel display blinks during this process, and you can turn on this receiver once it has stopped blinking. When you set **ARC** at HDMI setup to **OFF**, you can skip this process. For details, see *ARC (Audio Return Channel) function* on page 27.

- 1 **Plug the supplied power cord into the AC IN socket on the back of the receiver.**
- 2 **Plug the other end into a power outlet.**







## Saving station presets

If you often listen to a particular radio station, it's convenient to have the receiver store the frequency for easy recall whenever you want to listen to that station. This saves the effort of manually tuning in each time. This unit can memorize up to 30 stations.

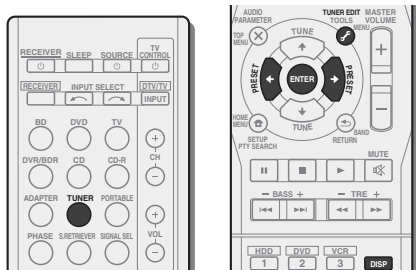

### 1 Tune to a station you want to memorize.

See *Listening to the radio* on page 18 for more on this.

### 2 Press TUNER EDIT.

The display shows **PRESET**, then a blinking **MEM** and station preset.

### 3 Press PRESET $\leftarrow/\rightarrow$ to select the station preset you want.

You can also use the number buttons.

### 4 Press ENTER.

The preset number stop blinking and the receiver stores the station.

#### Note

- If the receiver is left disconnected from the AC power outlet for over a month, the station memories will be lost and will have to be reprogrammed.
- Stations are stored in stereo. When the station is stored in the FM MONO mode, it shows as **ST** when recalled.

## Listening to station presets

You will need to have some presets stored to do this. See *Saving station presets* above if you haven't done this already.

### • Press PRESET $\leftarrow/\rightarrow$ to select the station preset you want.

- You can also use the number buttons on the remote control to recall the station preset.

## Naming preset stations

For easier identification, you can name all of your preset stations.

### 1 Choose the station preset you want to name.

See *Listening to station presets* above for how to do this.

### 2 Press TUNER EDIT twice.

The cursor at the first character position is blinking on the display.

### 3 Input the name you want.

Choose a name up to eight characters long.

- Use **PRESET**  $\leftarrow/\rightarrow$  to select character position.
- Use **TUNE**  $\uparrow/\downarrow$  to select characters.
- The name is stored when **ENTER** is pressed.

#### Tip

- To erase a station name, follow steps 1 and 2, and press **ENTER** while the display is blank. Press **TUNER EDIT** while the display is blank, to keep the previous name.
- Once you have named a station preset, Press **DISP** to show the name. When you want to return to the frequency display, press **DISP** several times to show the frequency.

## An introduction to RDS

Radio Data System (RDS) is a system used by most FM radio stations to provide listeners with various kinds of information—the name of the station and the kind of show they're broadcasting, for example.

One feature of RDS is that you can search by type of program. For example, you can search for a station that's broadcasting a show with the program type, **JAZZ**.

You can search the following program types:

**NEWS** – News

**AFFAIRS** – Current Affairs

**INFO** – General Information

**SPORT** – Sport

**EDUCATE** – Educational

**DRAMA** – Radio plays, etc.

**CULTURE** – National or regional culture, theater, etc.

**SCIENCE** – Science and technology

**VARIED** – Usually talk-based material, such as quiz shows or interviews.

**POP M** – Pop music

**ROCK M** – Rock music

**EASY M** – Easy listening

**LIGHT M** – 'Light' classical music

**CLASSICS** – 'Serious' classical music

**OTHER M** – Music not fitting above categories

**WEATHER** – Weather reports

**FINANCE** – Stock market reports, commerce, trading, etc.

**CHILDREN** – Programs for children

**SOCIAL** – Social affairs

**RELIGION** – Programs concerning religion

**PHONE IN** – Public expressing their views by phone

**TRAVEL** – Holiday-type travel rather than traffic announcements

**LEISURE** – Leisure interests and hobbies

**JAZZ** – Jazz

**COUNTRY** – Country music

**NATION M** – Popular music in a language other than English

**OLDIES** – Popular music from the '50s and '60s

**FOLK M** – Folk music

**DOCUMENT** – Documentary

#### Note

- In addition, there are three other program types, **ALARM**, **ALARMST**, and **NO TYPE**. **ALARM** and **ALARMST** are used for emergency announcements. **NO TYPE** appears when a program type cannot be found.



## Chapter 4: Listening to your system

### Choosing the listening mode

This receiver offers a variety of listening modes to accommodate playback of various audio formats. Choose one according to your speaker environment or the source.

- While listening to a source, press the listening mode button repeatedly to select a listening mode you want.

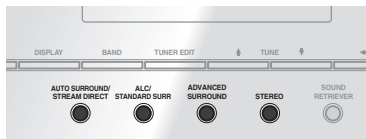
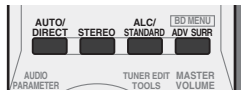

- The listening mode is shown on the display on the front panel.

#### Important

- The listening modes and many features described in this section may not be available depending on the current source, settings and status of the receiver.

### Auto playback

The simplest, most direct listening option is the **AUTO SURROUND** feature. With this, the receiver automatically detects what kind of source you're playing and selects multichannel or stereo playback as necessary.

- Press **AUTO/DIRECT** repeatedly until **AUTO SURROUND** shows briefly in the display (it will then show the decoding or playback format). Check the digital format indicators in the display to see how the source is being processed.

#### Note

- Stereo surround (matrix) formats are decoded accordingly using **NEO:6 CINEMA** or **DOLBY PLIIX MOVIE** (see *Listening in surround sound* below for more on these decoding formats).

### Listening in surround sound



Using this receiver, you can listen to any source in surround sound. However, the options available will depend on your speaker setup and the type of source you're listening to.

- If the source is Dolby Digital, DTS, or Dolby Surround encoded, the proper decoding format will automatically be selected and shows in the display.

When you select **STEREO ALC** (Auto Level Control stereo mode), this unit equalizes playback sound levels if each sound level varies with the music source recorded in a portable audio player.

When you select **STEREO**, you will hear the source through just the front left and right speakers (and possibly your subwoofer depending on your speaker settings). Dolby Digital and DTS multichannel sources are downmixed to stereo.

The following modes provide basic surround sound for stereo and multichannel sources.

#### Explanatory notes

No: No connected / Yes: Connected / Two: Two speakers are connected / -: Whether connected or no

Type of surround modes	Suitable sources	Surround back speaker(s)
<b>Two channel sources</b>		
<b>STEREO ALC</b>	See above.	–
<b>DOLBY PLIIX MOVIE</b>	Movie	Yes <sup>a</sup>
<b>DOLBY PLII MOVIE</b>		No
<b>DOLBY PLIIX MUSIC<sup>b</sup></b>	Music	Yes <sup>a</sup>
<b>DOLBY PLII MUSIC<sup>b</sup></b>		No
<b>DOLBY PLIIX GAME</b>	Video games	Yes <sup>a</sup>
<b>DOLBY PLII GAME</b>		No

Type of surround modes	Suitable sources	Surround back speaker(s)
<b>NEO:6 CINEMA<sup>c</sup></b>	Movie	–
<b>NEO:6 MUSIC<sup>c</sup></b>	Music	–
<b>DOLBY PRO LOGIC</b>	Old movies	–
Straight Decode <sup>d</sup>	No additional effects	–
<b>STEREO<sup>e</sup></b>	See above.	–
<b>Multichannel sources</b>		
<b>STEREO ALC</b>	See above.	–
<b>DOLBY PLIIX MOVIE</b>	Movie	Two <sup>a</sup>
<b>DOLBY PLII MOVIE</b>		No
<b>DOLBY PLIIX MUSIC<sup>b</sup></b>	Music	Yes
<b>DOLBY PLII MUSIC<sup>b</sup></b>		No
<b>DOLBY DIGITAL EX</b>	Movie/Music	Yes
<b>DTS-ES</b>	Movie/Music	Yes
<b>DTS NEO:6</b>	Movie/Music	Yes
Straight Decode <sup>d</sup>	No additional effects	–
<b>STEREO<sup>e</sup></b>	See above.	–

- If surround back channel processing (page 23) is switched off, or the surround back speakers are set to **NO**, **DOLBY PLIIX** becomes **DOLBY PLII** (5.1 channel sound).
- You can also adjust the **C.WIDTH**, **DIMEN.**, and **PNRM** effect (see *Setting the Audio options* on page 23).
- You can also adjust the **C.IMG** effect (see *Setting the Audio options* on page 23).
- This mode can only be selected when surround back channel processing (page 23) is switched off.
- You can choose the **STEREO** mode by using **STEREO** button.
  - The audio is heard with your surround settings and you can still use the Midnight, Loudness, Phase Control, Sound Retriever and Tone functions.

#### Note

- In modes that give 6.1 channel sound, the same signal is heard from both surround back speakers.

### Using the Advanced surround



The Advanced surround feature creates a variety of surround effects. Try different modes with various soundtracks to see which you like.

<b>ACTION</b>	Designed for action movies with dynamic soundtracks.
<b>DRAMA</b>	Designed for movies with lots of dialog.
<b>ENT.SHOW</b>	Suitable for musical sources.
<b>ADVANCED GAME</b>	Suitable for video games.
<b>SPORTS</b>	Suitable for sports programs.
<b>CLASSICAL</b>	Gives a large concert hall-type sound.
<b>ROCK/POP</b>	Creates a live concert sound for rock and/or pop music.
<b>UNPLUGGED</b>	Suitable for acoustic music sources.
<b>EXT.STEREO</b>	Gives multichannel sound to a stereo source, using all of your speakers.
<b>F.S.S.ADVANCE</b> (Front Stage Surround ADVANCE)	Allows you to create natural surround sound effects using just the front speakers and the subwoofer. Use to provide a rich surround sound effect directed to the center of where the front left and right speakers sound projection area converges.
<b>PHONES SURR</b>	When listening through headphones, you can still get the effect of overall surround.

### Using Stream Direct



Use the Stream Direct modes when you want to hear the truest possible reproduction of a source. All unnecessary signal processing is bypassed.

**AUTO SURROUND** See *Auto playback* on page 21.

<b>DIRECT</b>	Sources are heard according to the settings made in the Speaker Setup (speaker setting, channel level, speaker distance), as well as with dual mono settings. You will hear sources according to the number of channels in the signal. Phase Control, Sound Delay, Auto Delay, LFE Attenuate and Center image functions are available.
<b>PURE DIRECT</b>	Analog and PCM sources are heard without any digital processing.

### Using the Sound Retriever

When audio data is removed during the compression process, sound quality often suffers from an uneven sound image. The Sound Retriever feature employs new DSP technology that helps bring CD quality sound back to compressed 2-channel audio by restoring sound pressure and smoothing jagged artifacts left over after compression.

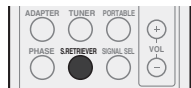

● Press **S.RETRIEVER** to switch the **S.RTV (Sound Retriever)** ON or OFF.

#### Note

- The Sound Retriever is only applicable to 2-channel sources.

### Better sound using Phase Control

This receiver's Phase Control feature uses phase correction measures to make sure your sound source arrives at the listening position in phase, preventing unwanted distortion and/or coloring of the sound.

Phase Control technology provides coherent sound reproduction through the use of phase matching for an optimal sound image at your listening position. The default setting is on and we recommend leaving Phase Control switched on for all sound sources.

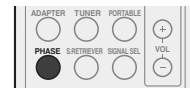

● Press **PHASE** to switch the **P.CTL (Phase Control)** ON or OFF.

#### Note

- Phase matching is a very important factor in achieving proper sound reproduction. If two waveforms are 'in phase', they crest and trough together, resulting in increased amplitude, clarity and presence of the sound signal. If a crest of a wave meets a trough, then the sound will be 'out of phase' and an unreliable sound image will be produced.
- If your subwoofer has a phase control switch, set it to the plus (+) sign (or 0°). However, the effect you can actually feel when Phase Control is set to **ON** on this receiver depends on the type of your subwoofer. Set your subwoofer to maximize the effect. It is also recommended you try changing the orientation or the place of your subwoofer.
- Set the built-in lowpass filter switch of your subwoofer to OFF. If this cannot be done on your subwoofer, set the cutoff frequency to a higher value.
- If the speaker distance is not properly set, you may not have a maximized Phase Control effect.
- The Phase Control mode cannot be set to **ON** in the following cases:
  - When the **PURE DIRECT** mode is switched on.
  - When the headphones are connected.

### Using surround back channel processing

You can have the receiver automatically use 6.1 or 7.1 decoding for 6.1 encoded sources (for example, Dolby Digital EX or DTS-ES), or you can choose to always use 6.1 or 7.1 decoding (for example, with 5.1 encoded material). With 5.1 encoded sources, a surround back channel will be generated, but the material may sound better in the 5.1 format for which it was originally encoded (in which case, you can simply switch surround back channel processing off).

- With a 7.1-channel surround system, audio signals that have undergone matrix decoding processing through surround back channel processing to which the Up Mix function is added are output from the surround back speakers.

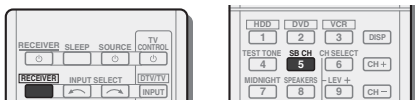

- Press **RECEIVER**, then press **SB CH** repeatedly to cycle the surround back channel options.

Each press cycles through the options as follows:

- **SB ON** – Matrix decoding processing for generating the surround back component from the surround component is turned on.
- **SB AUTO** – Matrix decoding processing for generating the surround back component from the surround component is switched automatically. Matrix decoding processing is only performed when surround back channel signals are detected in the input signals.
- **SB OFF** – Matrix decoding processing for generating the surround back component from the surround component is turned off.

### Setting the Up Mix function

In a 7.1-channel surround system with surround speakers placed directly at the sides of the listening position, the surround sound of 5.1-channel sources is heard from the side. The Up Mix function mixes the sound of the surround speakers with the surround back speakers so that the surround sound is heard from diagonally to the rear as it should be.

- Using the Up Mix function is effective when the speakers in the 7.1-channel surround system are set up as recommended in the example on page 10.
- Depending on the positions of the speakers and the sound source, in some cases it may not be possible to achieve good results. In this case, set the setting to **OFF**.

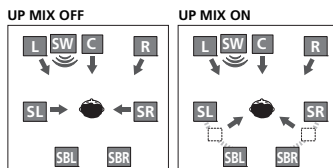

- 1 Switch the receiver into standby.
- 2 While holding down **PRESET** → on the front panel, and hold the **STANDBY/ON** for about two seconds. **UP MIX: OFF** appears and the Up Mix function turns off. If you want to turn this function on, perform steps 1 and 2 again.

- When set to **ON**, the **■** (Up Mix) indicator on the front panel lights.

#### Note

- Set to **ON** regardless of this setting when playing DTS-HD signals.
- May automatically be set to **OFF** even when set to **ON**, depending on the input signal and listening mode.

### Setting the Audio options

There are a number of additional sound settings you can make using the **AUDIO PARAMETER** menu. The defaults, if not stated, are listed in bold.

#### Important

- Note that if a setting doesn't appear in the **AUDIO PARAMETER** menu, it is unavailable due to the current source, settings and status of the receiver.

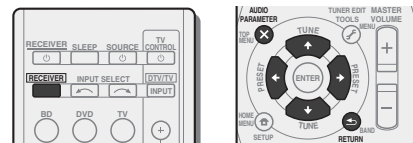

- 1 Press **RECEIVER**, then press **AUDIO PARAMETER** button.
- 2 Use **↑/↓** to select the setting you want to adjust. Depending on the current status/mode of the receiver, certain options may not be able to be selected. Check the table below for notes on this.
- 3 Use **←/→** to set it as necessary. See the table below for the options available for each setting.
- 4 Press **RETURN** to confirm and exit the menu.

Setting/What it does	Option(s)
<b>S.DELAY</b> (Sound Delay) Some monitors have a slight delay when showing video, so the soundtrack will be slightly out of sync with the picture. By adding a bit of delay, you can adjust the sound to match the presentation of the video.	0.0 to 9.0 (frames) 1 second = 25 frames (PAL) Default: <b>0.0</b>
<b>MIDNIGHT/LOUDNESS</b> <sup>a</sup> The <b>MIDNIGHT</b> allows you to hear effective surround sound of movies at low volumes. The <b>LOUDNESS</b> is used to get good bass and treble from music sources at low volumes.	<b>M/L OFF</b> <b>MIDNIGHT</b> <b>LOUDNESS</b>

Setting/What it does	Option(s)
<b>S.RTV</b> (Sound Retriever) <sup>b</sup> When audio data is removed during the compression process, sound quality often suffers from an uneven sound image. The Sound Retriever feature employs new DSP technology that helps bring CD quality sound back to compressed 2-channel audio by restoring sound pressure and smoothing jagged artifacts left over after compression.	<b>OFF</b> <hr/> <i>ON</i>
<b>DUAL MONO</b> <sup>c</sup> Specifies how dual mono encoded Dolby Digital soundtracks should be played.	<b>CH1</b> – Channel 1 is heard only <hr/> <b>CH2</b> – Channel 2 is heard only <hr/> <b>CH1 CH2</b> – Both channels heard from front speakers
<b>F.PCM</b> (Fixed PCM) This is useful if you find there is a slight delay before <b>OFF</b> recognizes the PCM signal on a CD, for instance. When <b>ON</b> is selected, noise may be output during playback of non-PCM sources. Please select another input signal if this is a problem.	<b>OFF</b> <hr/> <i>ON</i>
<b>DRC</b> (Dynamic Range Control) Adjusts the level of dynamic range for movie soundtracks optimized for Dolby Digital, DTS, Dolby Digital Plus, Dolby TrueHD, DTS-HD and DTS-HD Master Audio (you may need to use this feature when listening to surround sound at low volumes).	<b>AUTO</b> <sup>d</sup> <hr/> <i>MAX</i> <hr/> <i>MID</i> <hr/> <i>OFF</i>

Setting/What it does	Option(s)
<b>LFE ATT</b> (LFE Attenuate) Some Dolby Digital and DTS audio sources include ultra-low bass tones. Set the LFE attenuator as necessary to prevent the ultra-low bass tones from distorting the sound from the speakers. The LFE is not limited when set to 0 dB, which is the recommended value. When set to –15 dB, the LFE is limited by the respective degree. When <b>OFF</b> is selected, no sound is output from the LFE channel.	<b>0</b> (0 dB) <hr/> <i>5</i> (–5 dB) <hr/> <i>10</i> (–10 dB) <hr/> <i>15</i> (–15 dB) <hr/> <i>20</i> (–20 dB) <hr/> <b>**</b> ( <i>OFF</i> )
<b>HDMI</b> (HDMI Audio) Specifies the routing of the HDMI audio signal out of this receiver ( <b>AMP</b> ) or through to a TV ( <b>THRU</b> ). When <b>THRU</b> is selected, no sound is output from this receiver.	<b>AMP</b> <hr/> <i>THRU</i>
<b>A.DLY</b> (Auto Delay) <sup>e</sup> This feature automatically corrects the audio-to-video delay between components connected with an HDMI cable. The audio delay time is set depending on the operational status of the display connected with an HDMI cable. The video delay time is automatically adjusted according to the audio delay time.	<b>OFF</b> <hr/> <i>ON</i>
<b>C.WIDTH</b> (Center Width) <sup>f</sup> (Applicable only when using a center speaker) Spreads the center channel between the front right and left speakers, making it sound wider (higher settings) or narrower (lower settings).	<b>0 to 7</b> Default: <b>3</b>
<b>DIMEN</b> (Dimension) <sup>f</sup> Adjusts the surround sound balance from front to back, making the sound more distant (minus settings), or more forward (positive settings).	<b>–3 to +3</b> Default: <b>0</b>
<b>PNRM</b> . (Panorama) <sup>f</sup> Extends the front stereo image to include surround speakers for a 'wraparound' effect.	<b>OFF</b> <hr/> <i>ON</i>

Setting/What it does	Option(s)
<b>C.IMG</b> (Center Image) <sup>g</sup> (Applicable only when using a center speaker) Adjust the center image to create a wider stereo effect with vocals. Adjust the effect from <b>0</b> (all center channel sent to front right and left speakers) to <b>10</b> (center channel sent to the center speaker only).	<b>0 to 10</b> Default: <b>3</b> (NEO:6 MUSIC), <b>10</b> (NEO:6 CINEMA)
<b>a.</b> You can change the MIDNIGHT/LOUDNESS options at any time by using <b>MIDNIGHT</b> button. <b>b.</b> You can change the Sound Retriever feature at any time by using <b>S.RETRIEVER</b> button. <b>c.</b> This setting works only with dual mono encoded Dolby Digital and DTS soundtracks. <b>d.</b> The initial set <b>AUTO</b> is only available for Dolby TrueHD signals. Select <b>MAX</b> or <b>MID</b> for signals other than Dolby TrueHD. <b>e.</b> This feature is only available when the connected display supports the automatic audio/video synchronizing capability ('lip-sync') for HDMI. If you find the automatically set delay time unsuitable, set <b>A.DLY</b> to <b>OFF</b> and adjust the delay time manually. For more details about the lip-sync feature of your display, contact the manufacturer directly. <b>f.</b> Only available with 2-channel sources in <b>DOLBY PLII MUSIC</b> mode. <b>g.</b> Only when listening to 2-channel sources in <b>NEO:6 CINEMA</b> and <b>NEO:6 MUSIC</b> mode.	



## Chapter 5: The System Setup menu

### Using the System Setup menu

The following section shows you how to make detailed settings to specify how you're using the receiver, and also explains how to fine-tune individual speaker system settings to your liking.

#### Important

- If headphones are connected to the receiver, disconnect them.

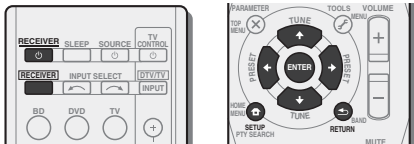

1 Press **RECEIVER** to switch the receiver on.

2 Press **RECEIVER**, then press **SETUP**.

The System Setup menu appears on the front panel display. Use **↑/↓/←/→** and **ENTER** on the remote control to navigate through the screens and select menu items. Press **RETURN** to confirm and exit the current menu.

- Press **SETUP** at any time to exit the System Setup menu.

3 Select the setting you want to adjust.

#### • SP SETUP

– **SP SET** – Specify the size and number of speakers you've connected (see below).

– **X.OVER** – Specify which frequencies will be sent to the subwoofer (page 26).

– **CH LEVEL** – Adjust the overall balance of your speaker system (page 26).

– **SP DISTN** – Specify the distance of your speakers from the listening position (page 26).

- **HDMI SET** – Set when using the ARC function. (see *ARC Setup* on page 27).

- **APD** – Sets to automatically turn off the power when the receiver has not operated for several hours (see *The Auto Power Down menu* on page 26).

- **FL DEMO** – Sets the demo display on the front panel display (see *The FL Demo Mode menu* on page 26).

### The Speaker Setup menu

This receiver allows you to make detailed settings to optimize the surround sound performance. You only need to make these settings once (unless you change the placement of your current speaker system or add new speakers).

#### Speaker Setting

Use this setting to specify your speaker configuration (size, number of speakers).

1 Use **↑/↓** to select '**SP SETUP**' from the System Setup menu, then press **ENTER**.

2 Use **↑/↓** to select '**SP SET**' from the SP SETUP menu, then press **ENTER**.

3 Use **↑/↓** to select the set of speakers that you want to set then select a speaker size.

Use **←/→** to select the size (and number) of each of the following speakers:

- **F (Front)** – Select **LARGE** if your front speakers reproduce bass frequencies effectively, or if you didn't connect a subwoofer. Select **SMALL** to send the bass frequencies to the subwoofer.

- **C (Center)** – Select **LARGE** if your center speaker reproduces bass frequencies effectively, or select **SMALL** to send bass frequencies to the other speakers or subwoofer. If you didn't connect a center speaker, choose **NO** (the center channel is sent to the other speakers).

- **S (Surround)** – Select **LARGE** if your surround speakers reproduce bass frequencies effectively. Select **SMALL** to send bass frequencies to the other speakers or subwoofer. If you didn't connect surround speakers choose **NO** (the sound of the surround channels is sent to the other speakers).

- **SB (Surround Back)** – Select the number of surround back speakers you have (one (**X1**), two (**X2**) or none). Select **L (LARGE)** if your surround back speakers reproduce bass frequencies effectively. Select **S (SMALL)** to send bass frequencies to the other speakers or subwoofer. If you didn't connect surround back speakers choose **NO**.

– If you select one surround back speaker only, make sure that additional amplifier is hooked up to the **PRE OUT L (Single)** terminal.

- **SW (Subwoofer)** – LFE signals and bass frequencies of channels set to **SMALL** are output from the subwoofer when **YES** is selected (see notes below). Choose the **PLUS** setting if you want the subwoofer to output bass sound continuously or you want deeper bass (the bass frequencies that would normally come out the front and center speakers are also routed to the subwoofer). If you did not connect a subwoofer choose **NO** (the bass frequencies are output from other speakers).

4 When you're finished, press **RETURN**.

You return to the Speaker Setup menu.

#### Note

- If you select **SMALL** for the front speakers, the subwoofer will automatically be fixed to **YES**. Also, the center, surround and surround back speakers can't be set to **LARGE (L)** if the front speakers are set to **SMALL**. In this case, all bass frequencies are sent to the subwoofer.

- If the surround speakers are set to **NO**, the surround back speakers will automatically be set to **NO**.

- If you have a subwoofer and like lots of bass, it may seem logical to select **LARGE** for your front speakers and **PLUS** for the subwoofer. This may not, however, yield the best bass results. Depending on the speaker placement of your room you may actually experience a decrease in the amount of bass due to low frequency cancellations. In this case, try changing the position or direction of speakers. If you can't get good results, listen to the bass response with it set to **PLUS** and **YES** or the front speakers set to **LARGE** and **SMALL** alternatively and let your ears judge which sounds best. If you're having problems, the easiest option is to route all the bass sounds to the subwoofer by selecting **SMALL** for the front speakers.

### X.Over

- Default setting: **100Hz**

This setting decides the cutoff between bass sounds playing back from the speakers selected as **LARGE**, or the subwoofer, and bass sounds playing back from those selected as **SMALL**. It also decides where the cutoff will be for bass sounds in the LFE channel.

- For more on selecting the speaker sizes, see *Speaker Setting* on page 26.

**1 Use ↑/↓ to select 'SP SETUP' from the System Setup menu, then press ENTER.**

**2 Use ↑/↓ to select 'X.OVER' from the SP SETUP menu, then press ENTER.**

**3 Use ←/→ to select the frequency cutoff point.** Frequencies below the cutoff point will be sent to the subwoofer (or **LARGE** speakers).

**4 When you're finished, press RETURN.** You return to the Speaker Setup menu.

### Channel Level

Using the channel level settings, you can adjust the overall balance of your speaker system, an important factor when setting up a home theater system.

#### CAUTION

- The test tones used in the System Setup are output at high volume.

**1 Use ↑/↓ to select 'SP SETUP' from the System Setup menu, then press ENTER.**

**2 Use ↑/↓ to select 'CH LEVEL' from the SP SETUP menu, then press ENTER.**

**3 Use ←/→ to select a setup option.**

- **T. TONE M** – Move the test tone manually from speaker to speaker and adjust individual channel levels.
- **T. TONE A** – Adjust channel levels as the test tone moves from speaker to speaker automatically.

**4 Confirm your selected setup option.**

The test tones will start after you press **ENTER**. After the volume increases to the reference level, test tones will be output.

**5 Use ←/→ to adjust the level of each channel.**

If you selected **T. TONE M**, use ↑/↓ to switch speakers. The **T. TONE A** setup outputs test tones in the following order (depends on speaker settings):

**L → C → R → SR → SBR → SBL → SL → SW**

Adjust the level of each speaker as the test tone is emitted.

#### Note

- If you are using a Sound Pressure Level (SPL) meter, take the readings from your main listening position and adjust the level of each speaker to 75 dB SPL (C-weighting/slow reading).
- The subwoofer test tone is output at low volumes. You may need to adjust the level after testing with an actual soundtrack.

**6 When you're finished, press RETURN.**

You return to the Speaker Setup menu.

#### Tip

- You can change the channel levels at any time by press **RECEIVER**, then press **CH SELECT** and **LEV +/-** on the remote control. You can also press **CH SELECT** and use ↑/↓ to select the channel, and then use ←/→ to adjust the channel levels.

### Speaker Distance

For good sound depth and separation from your system, you need to specify the distance of your speakers from the listening position. The receiver can then add the proper delay needed for effective surround sound.

**1 Use ↑/↓ to select 'SP SETUP' from the System Setup menu, then press ENTER.**

**2 Use ↑/↓ to select 'SP DISTN' from the SP SETUP menu, then press ENTER.**

**3 Use ↑/↓ to choose the speaker that you want then set the distance.**

Use ←/→ to adjust the distance of each speaker in 0.1 m increments.

**4 When you're finished, press RETURN.**

You return to the Speaker Setup menu.

### The Auto Power Down menu

Set to automatically turn off the receiver after a specified time has passed (when the power has been on with no operation for several hours).

- Default setting: **6 hours**

**1 Use ↑/↓ to select 'APD' from the System Setup menu, then press ENTER.**

**2 Specify the amount of time to allow before the power is turned off (when there has been no operation).**

- Use ←/→ to select 2, 4 or 6 hours, or **OFF** (if no automatic shutoff is desired).

**3 When you're finished, press RETURN.**

You return to the System Setup menu.

### The FL Demo Mode menu

Set whether or not various demos are to be shown on the front panel display.

- Default setting: **ON**

**1 Use ↑/↓ to select 'FL DEMO' from the System Setup menu, then press ENTER.**

**2 Use ←/→ to choose ON or OFF for the demo display.**

**3 When you're finished, press RETURN.**

You return to the System Setup menu.

## Chapter 6: ARC (Audio Return Channel) function

If your TV supports an audio return channel function, connect your TV and this unit with an HDMI cable and the TV audio will be inputted into this unit via the HDMI terminal without the need for an audio cable to be connected. Turn ON the "ARC" in the HDMI SETUP when using this function.





### Important

- Use a High Speed HDMI® Cable when using the ARC function. The ARC function may not operate properly with other HDMI cables.

### ARC Setup

**1 Press  RECEIVER to switch the receiver on.**

**2 Press [RECEIVER], then press SETUP.**

The System Setup menu appears on the front panel display. Use /// and **ENTER** on the remote control to navigate through the screens and select menu items. Press **RETURN** to confirm and exit the current menu.

- Press **SETUP** at any time to exit the System Setup menu.

**3 Use / to select 'HDMI SET' from the System Setup menu, then press ENTER.**

**4 Use / to choose the 'ARC' setting you want.**

When a TV supporting the HDMI Audio Return Channel function is connected to the receiver, the sound of the TV can be input via the HDMI terminal.

- **ON** – The TV's sound is input via the HDMI terminal.
- **OFF** – The TV's sound is input from the audio input terminals other than HDMI inputs.

**5 When you're finished, press RETURN.**

You return to the System Setup menu.

### Before starting ARC operation

When starting ARC operation, put the TV and this unit in STANDBY mode after connecting this unit with the TV. Next, turn ON the power of this unit and then the TV, in this order. In order to start ARC operation, after connecting this unit to a TV with an HDMI cable, you will need to switch the input on the TV to the input mode required to connect to this unit. Then, you can select a TV program.

### Important

- The ARC function may not operate even if the above conditions are met. If this is the case, listen to the TV audio after connecting this unit and the TV with an audio cable.
- The CEC (Consumer Electronic Control) function may activate when the ARC function is turned ON, causing power to turn ON and OFF and the input to switch from one to another. Since this unit does not guarantee synchronized operation based on the CEC function, we recommend that you turn OFF the HDMI CONTROL setting on the connected player. This unit may not operate properly if the HDMI CONTROL on the player is ON. Refer to the relevant device's instruction manual for details. If this does not work, turn OFF the ARC function. If this is the case, listen to the TV audio after connecting this unit and the TV with an audio cable. In addition, this unit does not guarantee synchronized operation that allows the TV remote control to operate the volume (including mute). Use this unit to operate the volume (including mute).
- Turn OFF the power and remove the power cord from the wall socket when connecting other devices or making connection changes to this unit. After all connections are completed, insert the power cord into the wall socket.
- If the power cord is connected when the ARC function is ON, the HDMI will take 2 to 10 seconds to initialize. This unit cannot be operated during the initialization. During initialization, the HDMI indicator on the display will blink. Turn ON the unit after blinking stops.

## Chapter 7:

## Additional information

## Troubleshooting

Incorrect operations are often mistaken for trouble and malfunctions. If you think that there is something wrong with this component, check the points below. Take a look at the other components and electrical appliances being used, because sometimes the problem may lie there. If the trouble isn't sorted out even after going through the checks below, ask your nearest Pioneer authorized independent service company to carry out repair work.

- If the unit does not operate normally due to external effects such as static electricity disconnect the power plug from the outlet and insert again to return to normal operating conditions.

## General

## The power does not turn on.

- Disconnect the power plug from the outlet, and insert again.
- Make sure there are no loose strands of speaker wire touching the rear panel. This could cause the receiver to shut off automatically.

## The receiver suddenly switches off.

- When the Auto Power Down function is working, the power will automatically turn off if the receiver has not operated for several hours. Check the setting for the Auto Power Down function (see *The Auto Power Down menu* on page 26).
- After about a minute (you won't be able to switch the unit on during this time), switch the receiver back on. If the message persists, call a Pioneer authorized independent service company.

## Power automatically turns ON/OFF and the input switches from one to another. (When the ARC function is ON)

- The CEC (Consumer Electronic Control) function may activate when the ARC function is turned ON, causing power to turn ON and OFF and the input to switch from one to another. Since this unit does not guarantee synchronized operation based on the CEC function, turn OFF the HDMI CONTROL setting on the connected player. Refer to the relevant device's instruction manual for details.
- If this does not work, turn OFF the ARC function. If this is the

case, listen to the TV audio after connecting this unit and the TV with an audio cable.

## No sound is output when an input function is selected.

- Use **MASTER VOLUME** to turn up the volume.
- Press **MUTE** on the remote control to turn muting off.
- Set the **SIGNAL SEL** to **H** (HDMI), **C1/O1** (digital) or **A** (analog) according to the type of connections made (refer to page 17).
- Make sure the component is connected correctly (refer to *Connecting your equipment* on page 10).
- Check the audio output settings of the source component.
- Refer to the instruction manual supplied with the source component.

## No image is output when an input function is selected.

- Make sure the component is connected correctly (refer to *Connecting your equipment* on page 10).
- Use the same type of video cables for the source component and TV to connect to this receiver (see *About video outputs connection* on page 13).
- The video input selected on the TV monitor is incorrect. Refer to the instruction manual supplied with the TV.

## No sound from subwoofer.

- Make sure the subwoofer is switched on.
- The Dolby Digital or DTS source you are listening to may not have an LFE channel.
- Switch the subwoofer setting in *Speaker Setting* on page 25 to **YES** or **PLUS**.
- Switch the **LFE ATT (LFE Attenuate)** on page 24 to **LFEATT 0** or **LFEATT 5**.

## No sound from surround or center speakers.

- Connect the speakers properly (refer to page 11).
- Refer to *Speaker Setting* on page 25 to check the speaker settings.
- Refer to *Channel Level* on page 26 to check the speaker levels.

## The Phase Control feature doesn't seem to have an audible effect.

- If applicable, check that the lowpass filter switch on your subwoofer is off, or the lowpass cutoff is set to the highest frequency setting. If there is a PHASE setting on your subwoofer, set it to 0° (or depending on the subwoofer, the setting where you think it has the best overall effect on the sound).
- Make sure the speaker distance setting is correct for all speakers (see *Speaker Distance* on page 26).

## Considerable noise in radio broadcasts.

- Connect the antenna (page 15) and adjust the position for best reception.
- Route any loose cables away from the antenna terminals and wires.
- Fully extend the FM wire antenna, position for best reception, and secure to a wall (or connect an outdoor FM antenna).
- Connect an additional internal or external AM antenna (page 16).
- Turn off equipment causing interference or move it away from the receiver (or move antennas farther away from equipment causing noise).

## Broadcast stations cannot be selected automatically.

- Connect an outdoor antenna (refer to page 16).

## Noise during playback of a cassette deck.

- Move the cassette deck away from your receiver, until the noise disappears.

## No sound is output or a noise is output when software with DTS is played back.

- Make sure the player's settings are correct and/or the DTS signal out is on. Refer to the instruction manual supplied with the DVD player.

## Can't operate the remote control.

- Replace the batteries (refer to page 9).
- Operate within 7 m, 30° of the remote sensor (refer to page 9).
- Remove the obstacle or operate from another position.
- Avoid exposing the remote sensor on the front panel to direct light.

## The display is dark or off.

- Press **DIMMER** on the remote control repeatedly to return to the default.

## The front panel display switches over to no apparent reason to various different displays.

- This happens because the demo display is in operation. To turn off the demo display, press any button to go back to the original display, or set the **FL DEMO** to **OFF** (see *The FL Demo Mode menu* on page 26).

## TEMP shows in the display and the volume level drops.

- The temperature within the unit has exceeded the allowable value. Try moving the unit for better ventilation (see page 2).
- Lower the volume level.

## HDMI

### No picture or sound.

→ If the problem still persists when connecting your HDMI component directly to your monitor, please consult the component or monitor manual or contact the manufacturer for support.

### No picture.

→ Video signals that are input from the analog video terminal will not output from the HDMI terminal. Signals that are input from the HDMI terminal will not output from the analog video terminal. Be consistent with the type of cable between input and output.

→ Depending in the output settings of the source component, it may be outputting a video format that can't be displayed. Change the output settings of the source, or connect using the composite jacks.

→ This receiver is HDCP-compatible. Check that the components you are connecting are also HDCP-compatible. If they are not, please connect them using the composite video jacks.

→ Depending on the connected source component, it's possible that it will not work with this receiver (even if it is HDCP-compatible). In this case, connect using the composite video jacks between source and receiver.

→ If video images do not appear on your TV, try adjusting the resolution, Deep Color or other setting for your component.

→ To output signals in Deep Color, use an HDMI cable (High Speed HDMI® Cable) to connect this receiver to a component or TV with the Deep Color feature.

### No sound, or sound suddenly ceases.

→ Check that the Audio Parameter setting is set to **HDMI AMP/THRU** (refer to page 23).

→ If the component is a DVI device, use a separate connection for the audio.

→ HDMI format digital audio transmissions require a longer time to be recognized. Due to this, interruption in the audio may occur when switching between audio formats or beginning playback.

→ Turning on/off the device connected to this unit's HDMI OUT terminal during playback, or disconnecting/connecting the HDMI cable during playback, may cause noise or interrupted audio.

## Important information regarding the HDMI connection

There are cases where you may not be able to route HDMI signals through this receiver (this depends on the HDMI equipped component you are connecting-check with the manufacturer for HDMI compatibility information).

If you aren't receiving HDMI signals properly through this receiver (from your component), please try the following configuration when connecting up.

### Configuration

Connect your HDMI-equipped component directly to the display using an HDMI cable. Then use the most convenient connection (digital is recommended) for sending audio to the receiver. See the operating instructions for more on audio connections. Set the display volume to minimum when using this configuration.

### Note

- Depending on the component, audio output may be limited to the number of channels available from the connected display unit (for example audio output is reduced to 2 channels for a monitor with stereo audio limitations).
- If you want to switch the input source, you'll have to switch functions on both the receiver and your display unit.
- Since the sound is muted on the display when using the HDMI connection, you must adjust the volume on the display every time you switch input sources.

## Resetting the main unit

Use this procedure to reset all the receiver's settings to the factory default. Use the front panel controls to do this.

- 1 **Switch the receiver into standby.**
- 2 **While holding down BAND, press and hold  STANDBY/ON for about two seconds.**
- 3 **When you see RESET? appear in the display, press AUTO SURROUND/STREAM DIRECT.**  
**OK?** shows in the display.
- 4 **Press ALC/STANDARD SURR to confirm.**  
**OK** appears in the display to indicate that the receiver has been reset to the factory default settings.

### Important

- If the ARC function is ON, you may not be able to initialize the unit. If this happens, turn OFF the ARC function or turn OFF all the connected device before turning OFF (STANDBY) the power for this unit, and initialize after the HDMI indicator goes out.

## Cleaning the unit

- Use a polishing cloth or dry cloth to wipe off dust and dirt.
- When the surface is dirty, wipe with a soft cloth dipped in some neutral cleanser diluted five or six times with water, and wrung out well, and then wipe again with a dry cloth. Do not use furniture wax or cleansers.
- Never use thinners, benzene, insecticide sprays or other chemicals on or near this unit, since these will corrode the surface.

## Specifications

### Audio section

Rated power output	
Front, Center, Surround	
.....	100 W per channel (1 kHz, 6 Ω, 0.7 %)
Total Harmonic Distortion	
.....	0.06 % (20 Hz to 20 kHz, 8 Ω, 50 W/ch)
Frequency response (LINE Pure Direct mode)	
.....	10 Hz to 70 kHz $\pm 3$ dB
Guaranteed speaker impedance	
.....	6 Ω to 16 Ω
Input (Sensitivity/Impedance)	
LINE	200 mV/47 kΩ
Output (Level/Impedance)	
REC	200 mV/2.2 kΩ
Signal-to-Noise Ratio (IHF, short circuited, A network)	
LINE	98 dB

### Video section

Signal level	
Composite	1 Vp-p (75 Ω)

### Tuner section

Frequency Range (FM)	87.5 MHz to 108 MHz
Antenna Input (FM)	75 Ω unbalanced
Frequency Range (AM)	531 kHz to 1602 kHz
Antenna (AM)	Loop antenna

### Digital In/Out section

HDMI terminal	Type A (19-pin)
HDMI output type	5 V, 100 mA

### Miscellaneous

Power Requirements	AC 220 V to 230 V, 50 Hz/60 Hz
Power Consumption	180 W
In standby	0.45 W
	(ARC function: OFF)
Dimensions	435 mm (W) x 168 mm (H) x 362.5 mm (D)
Weight (without package)	7.5 kg

### Furnished Parts

Remote control	1
Dry cell batteries (AAA size IEC R03)	2
AM loop antenna	1
FM wire antenna	1
Warranty card	1
Power cord	
Quick start guide	
These operating instructions (CD-ROM)	

### Note

- The specifications are applicable when the power supply is 230 V.
- Specifications and the design are subject to possible modifications without notice, due to improvements.



Manufactured under license from Dolby Laboratories. "Dolby", "Pro Logic", "Surround EX", and the double-D symbol are trademarks of Dolby Laboratories.



Manufactured under license under U.S. Patent Nos: 5,956,674; 5,974,380; 6,226,616; 6,487,535; 7,212,872; 7,333,929; 7,392,195; 7,272,567 & other U.S. and worldwide patents issued & pending. DTS-HD, the Symbol, & DTS-HD and the Symbol together are registered trademarks & DTS-HD Master Audio is a trademark of DTS, Inc. Product includes software. © DTS, Inc. All Rights Reserved.

<http://www.pioneer.co.uk>

<http://www.pioneer.eu>

© 2012 PIONEER CORPORATION.  
All rights reserved.

---

**PIONEER CORPORATION**

1-1, Shin-ogura, Saiwai-ku, Kawasaki-shi, Kanagawa 212-0031, Japan

**PIONEER ELECTRONICS (USA) INC.**

P.O. BOX 1540, Long Beach, California 90801-1540, U.S.A. TEL: (800) 421-1404

**PIONEER ELECTRONICS OF CANADA, INC.**

340 Ferrier Street, Unit 2, Markham, Ontario L3R 2Z5, Canada TEL: 1-877-283-5901, 905-479-4411

**PIONEER EUROPE NV**

Haven 1087, Keetberglaan 1, B-9120 Melsele, Belgium TEL: 03/570.05.11

**PIONEER ELECTRONICS ASIACENTRE PTE. LTD.**

253 Alexandra Road, #04-01, Singapore 159936 TEL: 65-6472-7555

**PIONEER ELECTRONICS AUSTRALIA PTY. LTD.**

5 Arco Lane, Heatherton, Victoria, 3202, Australia, TEL: (03) 9586-6300

**PIONEER ELECTRONICS DE MEXICO S.A. DE C.V.**

Bldv.Manuel Avila Camacho 138 10 piso Col.Lomas de Chapultepec, Mexico, D.F. 11000 TEL: 55-9178-4270

K002\_B3\_En

<ARB7494-A>

## Free Manuals Download Website

<http://myh66.com>

<http://usermanuals.us>

<http://www.somanuals.com>

<http://www.4manuals.cc>

<http://www.manual-lib.com>

<http://www.404manual.com>

<http://www.luxmanual.com>

<http://aubethermostatmanual.com>

Golf course search by state

<http://golfingnear.com>

Email search by domain

<http://emailbydomain.com>

Auto manuals search

<http://auto.somanuals.com>

TV manuals search

<http://tv.somanuals.com>