

Pioneer

Operating Instructions

audio/video multi-channel receiver

VSX-LX52

IMPORTANT



The lightning flash with arrowhead symbol, within an equilateral triangle, is intended to alert the user to the presence of uninsulated "dangerous voltage" within the product's enclosure that may be of sufficient magnitude to constitute a risk of electric shock to persons.

CAUTION

RISK OF ELECTRIC SHOCK
DO NOT OPEN

CAUTION:

TO PREVENT THE RISK OF ELECTRIC SHOCK, DO NOT REMOVE COVER (OR BACK). NO USER-SERVICEABLE PARTS INSIDE. REFER SERVICING TO QUALIFIED SERVICE PERSONNEL.



The exclamation point within an equilateral triangle is intended to alert the user to the presence of important operating and maintenance (servicing) instructions in the literature accompanying the appliance.

D3-4-2-1-1_A1_En

Replacement and mounting of an AC plug on the power supply cord of this unit should be performed only by qualified service personnel.

IMPORTANT: THE MOULDED PLUG

This appliance is supplied with a moulded three pin mains plug for your safety and convenience. A 10 amp fuse is fitted in this plug. Should the fuse need to be replaced, please ensure that the replacement fuse has a rating of 10 amps and that it is approved by ASTA or BSI to BS1362.

Check for the ASTA mark  or the BSI mark  on the body of the fuse.

If the plug contains a removable fuse cover, you must ensure that it is refitted when the fuse is replaced. If you lose the fuse cover the plug must not be used until a replacement cover is obtained. A replacement fuse cover can be obtained from your local dealer.

If the fitted moulded plug is unsuitable for your socket outlet, then the fuse shall be removed and the plug cut off and disposed of safely. There is a danger of severe electrical shock if the cut off plug is inserted into any 13 amp socket.

If a new plug is to be fitted, please observe the wiring code as shown below. If in any doubt, please consult a qualified electrician.

IMPORTANT: The wires in this mains lead are coloured in accordance with the following code:

Blue : Neutral Brown : Live

As the colours of the wires in the mains lead of this appliance may not correspond with the coloured markings identifying the terminals in your plug, proceed as follows :

The wire which is coloured BLUE must be connected to the terminal which is marked with the letter **N** or coloured BLACK.

The wire which is coloured BROWN must be connected to the terminal which is marked with the letter **L** or coloured RED.

How to replace the fuse: Open the fuse compartment with a screwdriver and replace the fuse.

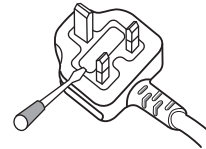

D3-4-2-1-2-2_B_En

WARNING

Before plugging in for the first time, read the following section carefully.

The voltage of the available power supply differs according to country or region. Be sure that the power supply voltage of the area where this unit will be used meets the required voltage (e.g., 230 V or 120 V) written on the rear panel.

D3-4-2-1-4_A_En

WARNING

To prevent a fire hazard, do not place any naked flame sources (such as a lighted candle) on the equipment.

D3-4-2-1-7a_A_En

WARNING

This equipment is not waterproof. To prevent a fire or shock hazard, do not place any container filled with liquid near this equipment (such as a vase or flower pot) or expose it to dripping, splashing, rain or moisture.

D3-4-2-1-3_B_En

This product complies with the Low Voltage Directive 2006/95/EC and EMC Directive 2004/108/EC.

D3-4-2-1-9a_A1_En

Information for users on collection and disposal of old equipment and used batteries

(Symbol for equipment)



These symbols on the products, packaging, and/or accompanying documents mean that used electrical and electronic products and batteries should not be mixed with general household waste.

For proper treatment, recovery and recycling of old products and used batteries, please take them to applicable collection points in accordance with your national legislation.

(Symbol examples for batteries)



By disposing of these products and batteries correctly, you will help to save valuable resources and prevent any potential negative effects on human health and the environment which could otherwise arise from inappropriate waste handling.

For more information about collection and recycling of old products and batteries, please contact your local municipality, your waste disposal service or the point of sale where you purchased the items.



These symbols are only valid in the European Union.

For countries outside the European Union:

If you wish to discard these items, please contact your local authorities or dealer and ask for the correct method of disposal.

K058a_A1_En

VENTILATION CAUTION

When installing this unit, make sure to leave space around the unit for ventilation to improve heat radiation (at least 60 cm at top, 10 cm at rear, and 30 cm at each side).

WARNING

Slots and openings in the cabinet are provided for ventilation to ensure reliable operation of the product, and to protect it from overheating. To prevent fire hazard, the openings should never be blocked or covered with items (such as newspapers, table-cloths, curtains) or by operating the equipment on thick carpet or a bed.

D3-4-2-1-7b_A_En

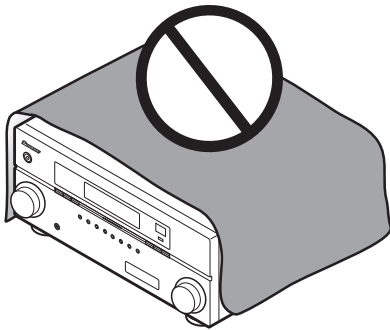

Operating Environment

Operating environment temperature and humidity: +5 °C to +35 °C (+41 °F to +95 °F); less than 85 %RH (cooling vents not blocked)

Do not install this unit in a poorly ventilated area, or in locations exposed to high humidity or direct sunlight (or strong artificial light)

D3-4-2-1-7c_A_En

This product is for general household purposes. Any failure due to use for other than household purposes (such as long-term use for business purposes in a restaurant or use in a car or ship) and which requires repair will be charged for even during the warranty period.

K041_En

CAUTION

The STANDBY/ON switch on this unit will not completely shut off all power from the AC outlet. Since the power cord serves as the main disconnect device for the unit, you will need to unplug it from the AC outlet to shut down all power. Therefore, make sure the unit has been installed so that the power cord can be easily unplugged from the AC outlet in case of an accident. To avoid fire hazard, the power cord should also be unplugged from the AC outlet when left unused for a long period of time (for example, when on vacation).

D3-4-2-2-2a_A_En

If the AC plug of this unit does not match the AC outlet you want to use, the plug must be removed and appropriate one fitted. Replacement and mounting of an AC plug on the power supply cord of this unit should be performed only by qualified service personnel. If connected to an AC outlet, the cut-off plug can cause severe electrical shock. Make sure it is properly disposed of after removal. The equipment should be disconnected by removing the mains plug from the wall socket when left unused for a long period of time (for example, when on vacation).

D3-4-2-2-1a_A_En

Contents

Flow of settings on the receiver	6	Connecting an HDMI-equipped component to the front panel input	35
01 Before you start		Connecting an iPod	36
Features	7	Connecting a USB device	36
Checking what's in the box	8	Plugging in the receiver	37
Installing the receiver	8	04 Basic Setup	
Loading the batteries	8	Switching the speaker impedance	38
Operating range of remote control unit	8	Changing the OSD display language (OSD Language)	38
02 Controls and displays		Automatically setting up for surround sound (Auto MCACC)	39
Remote control	9	Problems when using the Auto MCACC Setup	40
Front panel	11	The Input Setup menu	40
Display	12	Input function default and possible settings	41
03 Connecting your equipment		05 Basic playback	
Rear panel	14	Playing a source	42
Determining the speakers' application	16	Playing a source with HDMI connection	42
Other speaker connection	16	Selecting the multichannel analog inputs	43
Placing the speakers	17	Playing an iPod	43
THX speaker system setup	17	Playing back audio files stored on an iPod	43
Some tips for improving sound quality	18	Playing a USB device	45
Connecting the speakers	18	Playing back audio files stored on a USB memory device	45
Installing your speaker system	19	Playing back photo files stored on a USB memory device	46
Standard 5.1/6.1/7.1-channel surround connections	19	About playable file formats	47
Bi-amping your speakers	20	Listening to the radio	48
Bi-wiring your speakers	20	Improving FM sound	48
Selecting the Surr Back system	21	Using Neural THX	48
ZONE 2 setup	21	Tuning directly to a station	48
Speaker B setup	21	Saving station presets	48
Bi-Amping setup	21	Naming station presets	48
About the audio connection	21	Listening to station presets	49
About the video converter	22	An introduction to RDS	49
Connecting your TV and playback components	23	06 Listening to your system	
Connecting using HDMI	23	Auto playback	50
Connecting your DVD player with no HDMI output	24	Listening in surround sound	50
Connecting your TV with no HDMI input	25	Standard surround sound	50
Connecting an HDD/DVD recorder, VCR and other video sources	27	Using the Home THX modes	51
Connecting a satellite/cable receiver or other set-top box	28	Using the Advanced surround effects	51
Connecting the multichannel analog inputs	28	Listening in stereo	52
Connecting other audio components	28	Using Front Stage Surround Advance	52
About the WMA9 Pro decoder	29	Using Stream Direct	53
Connecting additional amplifiers	29	Using surround back channel processing	53
Connecting AM/FM antennas	30	Using the Virtual Surround Back mode	53
Connecting external antennas	30	Setting the Up Mix function	54
MULTI-ZONE setup	31	Selecting MCACC presets	54
Making MULTI-ZONE connections	31	Choosing the input signal	55
Connecting an IR receiver	33	Better sound using Phase Control	55
Operating other Pioneer components with this unit's sensor	33		
Switching components on and off using the 12 volt trigger	34		
Connecting a PC for Advanced MCACC output	34		

07 KURO LINK

Making the KURO LINK connections.....	57
Cautions on the KURO LINK function	57
About connections with a product of a different brand that supports the KURO LINK function	58
KURO LINK Setup.....	58
Setting the PQLS function	59
Before using synchronization	59
Synchronized amp mode.....	59
Synchronized amp mode operations.....	59
Canceling synchronized amp mode	59

08 Using other functions

Setting the Audio options	60
Setting the Video options.....	61
Switching the speaker system	63
Using the MULTI-ZONE controls	63
Making an audio or a video recording	64
Reducing the level of an analog signal	64
Using the sleep timer.....	65
Dimming the display	65
Switching the HDMI output.....	65
Checking your system settings	65
Resetting the system	66
Default system settings.....	66

09 Controlling the rest of your system

Operating multiple receivers	67
Setting the remote to control other components	67
Selecting preset codes directly	67
Resetting the remote control presets.....	68
Default preset codes	68
Controls the components	68

10 The Advanced MCACC menu

Making receiver settings from the Advanced MCACC menu	71
Automatic MCACC (Expert)	72
Manual MCACC setup.....	74
Fine Channel Level	75
Fine Speaker Distance.....	75
Standing Wave	76
Acoustic Calibration EQ Adjust.....	77
Acoustic Calibration EQ Professional	77
Checking MCACC Data	80
Speaker Setting.....	80
Channel Level	80
Speaker Distance	80
Standing Wave	81
Acoustic Cal EQ	81
Output PC.....	81
Data Management.....	82
Renaming MCACC presets	82
Copying MCACC preset data	82
Clearing MCACC presets.....	83

11 The system and the other setup

Making receiver settings from the System Setup menu.....	84
Manual speaker setup	84
Surround back speaker setting	85
Speaker Setting.....	85
Channel Level	86
Speaker Distance	87
X-Curve	87
THX Audio Setting.....	87
The Other Setup menu	88
Multi Channel Input Setup	89
ZONE Audio Setup	89
Power ON Level Setup.....	90
Volume Limit Setup.....	90
Remote Control Mode Setup.....	90
Flicker Reduction Setup	90

12 Additional information

Speaker Setting Guide.....	91
Positional relationship between speakers and monitor	92
Troubleshooting.....	92
Power	92
No sound	93
Other audio problems	94
Video.....	95
Settings.....	95
Professional Calibration EQ graphical output	96
Display	96
Remote control	97
HDMI	97
Important information regarding the HDMI connection	98
USB interface	99
Surround sound formats	100
Dolby.....	100
DTS.....	101
Windows Media Audio 9 Professional	101
About iPod	101
About THX	102
About Neural – THX Surround.....	103
Auto Surround, ALC and Stream Direct with different input signal formats.....	104
Preset code list	105
Specifications	113
Cleaning the unit.....	113
Our philosophy	113
Index.....	114

Flow of settings on the receiver

The unit is a full-fledged AV receiver equipped with an abundance of functions and terminals. It can be used easily after following the procedure below to make the connections and settings.

The colors of the steps indicate the following:

Required setting item

Setting to be made as necessary

1 Before you start

- Checking what's in the box (page 8)
- Loading the batteries (page 8)



2 Determining the speakers' application (page 16)

- 7.1ch surround connection
- 5.1ch surround & Front Bi-amping connection
- 5.1ch surround & ZONE 2 connection
- 5.1ch surround & Speaker B connection



3 Connecting the speakers

- Placing the speakers (page 17)
- Connecting the speakers (page 18)
- Standard 5.1/6.1/7.1-channel surround connections (page 19)
- Bi-amping your speakers (page 20)



4 Connecting the components

- About the audio connection (page 21)
- About the video converter (page 22)
- Connecting your TV and playback components (page 23)
- Connecting AM/FM antennas (page 30)
- Plugging in the receiver (page 37)



5 Switching the speaker impedance (page 38)

(Only if the impedance of the connected speakers is 6 Ω to 8 Ω)



6 Power On



7 Changing the OSD display language (OSD Language) (page 38)



8 Surround back speaker setting (page 85)



9 MCACC speaker settings

- Automatically setting up for surround sound (Auto MCACC) (page 39)



10 The Input Setup menu (page 40)

(When using connections other than the recommended connections)



11 Switching the HDMI output (page 65)



12 Basic playback (page 42)



13 Adjusting the sound and picture quality as desired

- Using the various listening modes
- Using surround back channel processing (page 53)
- Better sound using Phase Control (page 55)
- Measure the all EQ type (SYMMETRY/ALL CH ADJ/FRONT ALIGN) (page 72)
- Change the channel level while listening (*Tip* on page 86)
- Switches on/off the Acoustic Calibration EQ, Sound retriever or Dialog Enhancement (page 60)
- Setting the PQLS function (page 59)
- Setting the Audio options (Tone, Loudness or Sound delay, etc.) (page 60)
- Setting the Video options (page 61)



14 Other optional adjustments and settings

- KURO LINK Setup (page 58)
- The Advanced MCACC menu (page 71)
- The system and the other setup (page 84)



15 Making maximum use of the remote control

- Operating multiple receivers (page 67)
- Setting the remote to control other components (page 67)

Chapter 1: Before you start

Features

- **Advanced Direct Energy design**

This receiver offers a new advancement in discrete design unique to Pioneer for high-power drivability, low distortion and stable imaging. Through a circuit design that minimizes the energy loss of the amplifier for each of the channels, this receiver generates equal amplifier power to all channels, eliminating the possibility of one channel dominating a particular sound field.

- **Easy setup using Advanced MCACC**

The Auto MCACC Setup provides a quick but accurate surround sound setup, which includes the advanced features of Professional Acoustic Calibration EQ. This innovative technology measures the reverberant characteristics of your listening area, allowing you to customize your system calibration with the help of a graphical output that can be displayed on-screen or using computer. With the additional benefits of numerous MCACC preset memories, standing wave control and microphone measurements from a series of reference points, your home theater experience can be truly customized for optimal surround sound.

- **THX Select2 Plus certified design**

This receiver bears the THX Select2 Plus logo, which means it has passed a rigorous series of quality and performance tests covering every aspect of the product. This includes testing of pre-amplifier and power amplifier performance and operation, and hundreds of other parameters in both the digital and analog domain, making your home theater experience as faithful as possible to what the director intended.

- **Dolby Digital and DTS decoding, including Dolby Digital EX, Dolby Pro Logic IIx, DTS 96/24, DTS-ES, Dolby Digital Plus, Dolby TrueHD, DTS-EXPRESS and DTS-HD Master Audio**

Dolby Digital and DTS decoding brings theater sound right into your home with up to six channels of surround sound, including a special LFE (Low Frequency Effects) channel for deep, realistic sound effects.

The built-in Dolby Pro Logic IIx and DTS Neo:6 decoders not only provide full surround sound decoding for Dolby Surround sources, but will also generate convincing surround sound for any stereo source.

Also, with the addition of a surround back speaker, you can take advantage of the built-in Dolby Digital EX and DTS-ES decoders for six-channel surround sound.

Furthermore, Dolby Digital Plus and Dolby TrueHD, which are designed for the next-generation high-definition media such as Blu-ray Disc and HD DVD, support up to 7.1 channels and 8 channels respectively.

DTS-EXPRESS is a low-bitrate encoding technology supporting up to 5.1 channels, with fixed data transfer rates ranging from 24 kbps to 256 kbps (this encoding is available only when signals are delivered to this receiver as primary audio).

DTS-HD Master Audio delivers audio signals to listeners without any loss of data with its high transfer rates.

- **Phase Control**

The Phase Control technology incorporated into this receiver's design provides coherent sound reproduction through the use of phase matching for an optimal sound image at your listening position.

- **Sound Retriever**

The Sound Retriever feature employs DSP technology to restore sound pressure and smooth jagged artifacts left over after compression. This helps bring CD quality sound back to WMA, MP3 and MPEG-4 AAC audio files and achieves a richer sense of presence when playing Dolby Digital, DTS or WMA 9 Pro audio formats recorded in multiple channels on DVDs and other discs.

- **Front Stage Surround Advance**

With the Front Stage Surround Advance feature, you can enjoy seamless, natural surround sound effects using only the front speakers, without deteriorating the quality of the original sound.

- **Auto Level Control**

When the source is played in Auto level control mode (ALC), this receiver automatically equalizes the playback sound level according to the variation in recording levels.

- **HDMI and digital video conversion**

This receiver is compatible with the HDMI digital video format, providing you with high-definition digital video/audio via a single cable.

High-quality sound formats such as DTS-HD and Dolby TrueHD are supported while this receiver is also compatible with the DeepColor feature. You can operate this receiver in synchronization with your Pioneer component that supports the KURO LINK function by connecting your component to this receiver via HDMI. Also, the built-in digital video converter of this receiver makes both de-interlacing and up-scaling possible, and analog video signals being input are converted and output as digital video signals at the HDMI terminal.

• iPod and USB Ready

This receiver has the terminals for connecting an iPod unit and a USB mass storage device.

The iPod terminal is ready for handling digital audio, and this receiver's enhanced compatibility makes on-screen control of your iPod an added possibility.

The USB terminal allows you to listen to two-channel audio from a USB mass storage device connected to this receiver.

Checking what's in the box

Please check that you've received the following supplied accessories:

- Setup microphone (cable: 5 m)
- Remote control unit
- AA size IEC R6 dry cell batteries (to confirm system operation) x2
- AM loop antenna
- FM wire antenna
- iPod cable
- Power cord
- Warranty card
- These operating instructions

Installing the receiver

- When installing this unit, make sure to put it on a level and stable surface.

Don't install it on the following places:

- on a color TV (the screen may distort)
- near a cassette deck (or close to a device that gives off a magnetic field). This may interfere with the sound.
- in direct sunlight
- in damp or wet areas
- in extremely hot or cold areas
- in places where there is vibration or other movement
- in places that are very dusty
- in places that have hot fumes or oils (such as a kitchen)
- Do not touch this receiver's bottom panel while the power is turned on. The bottom panel gets hot when the power is on, and touching it could cause burns.

Loading the batteries

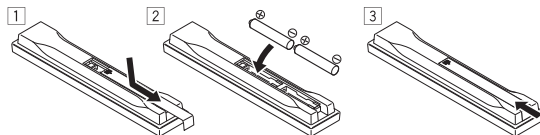

⚠ CAUTION

Incorrect use of batteries may result in such hazards as leakage and bursting. Observe the following precautions:

- Never use new and old batteries together.
- Insert the plus and minus sides of the batteries properly according to the marks in the battery case.
- Batteries with the same shape may have different voltages. Do not use different batteries together.
- When disposing of used batteries, please comply with governmental regulations or environmental public instruction's rules that apply in your country or area.

• WARNING

Do not use or store batteries in direct sunlight or other excessively hot place, such as inside a car or near a heater. This can cause batteries to leak, overheat, explode or catch fire. It can also reduce the life or performance of batteries.

Operating range of remote control unit

The remote control may not work properly if:

- There are obstacles between the remote control and the receiver's remote sensor.
- Direct sunlight or fluorescent light is shining onto the remote sensor.
- The receiver is located near a device that is emitting infrared rays.
- The receiver is operated simultaneously with another infrared remote control unit.

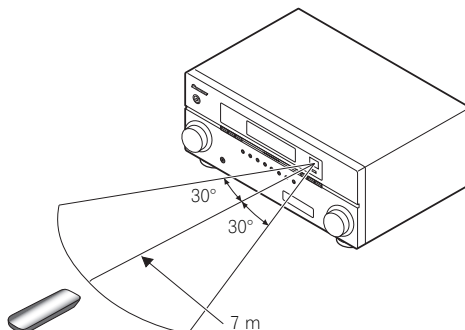

Chapter 2: Controls and displays

Remote control

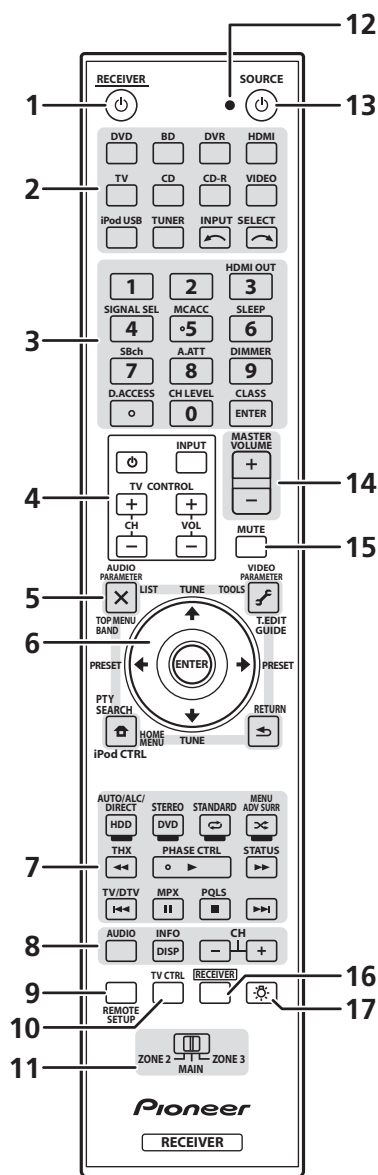

The remote has been conveniently color-coded according to component control using the following system:

- **White** – Receiver control, TV Control
- **Blue** – Other controls

1 RECEIVER

This switches between standby and on for this receiver.

2 **Input function buttons**

Press to select control of other components (see *Controlling the rest of your system* on page 67).

Use **INPUT SELECT** to select the input function (page 42).

3 **Number buttons and other receiver/component controls**

Use the number buttons to directly select a radio frequency (page 48) or the tracks on a CD, DVD, etc.

ENTER can be used to enter commands for TV or DTV.

Press **RECEIVER** first to access:

HDMI OUT – Switch the HDMI output terminal (page 65).

SIGNAL SEL – Use to select an input signal (page 55).

MCACC – Press to switch between MCACC presets (page 54).

SLEEP – Use to put the receiver in sleep mode and select the amount of time before sleep (page 65).

SBch – Use to select the surround back/virtual surround back channel mode (page 53).

A.ATT – Attenuates (lowers) the level of an analog input signal to prevent distortion (page 64).

DIMMER – Dims or brightens the display (page 65).

CH LEVEL – Press repeatedly to select a channel, then use **←/→** to adjust the level (page 86).

Press **TUNER** first to access:

D.ACCESS – After pressing, you can access a radio station directly using the number buttons (page 48).

CLASS – Switches between the seven banks (classes) of radio station presets (page 48).

4 **TV CONTROL buttons**

These buttons are dedicated to control the TV assigned to **TV** operation selector switch. Thus if you only have one TV to hook up to this system assign it to the **TV** operation selector switch (see page 68 for more on this).

⏻ – Use to turn on/off the power of the TV.

INPUT – Use to select the TV input signal.

CH +/- – Use to select channels.

VOL +/- – Use to adjust the volume on your TV.

5 Tuner/component control buttons/HOME MENU

These button controls can be accessed after you have selected the corresponding input function button (**DVD**, **DVR**, **TV**, etc.). The **BAND**, **T.EDIT** and **PTY SEARCH** tuner controls are explained on page 48.

Press **RECEIVER** first to access:

AUDIO PARAMETER – Use to access the Audio options (page 60).

VIDEO PARAMETER – Use to access the Video options (page 61).

HOME MENU – Use to access the Home Menu (pages 38, 40, 58, 71, 84 and 88).

RETURN – Press to confirm and exit the current menu screen (also use to return to the previous menu with DVDs or to select closed captioning with DTV).

6 ↑/↓/←/→ (TUNE/PRESET) /ENTER

Use the arrow buttons when setting up your surround sound system (see page 71) and the Audio or Video options (page 60 or 61). Also used to control DVD menus/options and for deck 1 of a double cassette deck player. Use **TUNE** ↑/↓ to find radio frequencies and use **PRESET** ←/→ to find preset stations (page 48).

7 Component/Receiver control buttons

The main buttons (▶, ■, etc.) are used to control a component after you have selected it using the input function buttons.

The controls above these buttons can be accessed after you have selected the corresponding input function button (for example **DVD**, **DVR** or **TV**). These buttons also function as described below.

Press **TUNER** first to access:

MPX – Switches between stereo and mono reception of FM broadcasts. If the signal is weak, then switching to mono will improve the sound quality (page 48).

Press **RECEIVER** first to access:

AUTO/ALC/DIRECT – Switches between Auto Surround (page 50), Auto level control mode and Stream Direct mode (page 53).

STEREO – Switches between stereo playback and Front Stage Surround Advance modes (page 52).

STANDARD – Press for Standard decoding and to switch between the various **DOLBY** Pro Logic IIx and Neo:6 options (page 50).

ADV SURR – Use to switch between the various surround modes (page 51).

THX – Press to select a Home THX listening mode (page 51).

PHASE CTRL – Press to switch on/off Phase Control (page 55).

STATUS – Press to check selected receiver settings (page 65).

PQLS – Press to select PQLS setting (page 59).

8 AUDIO – Changes the audio or channel on DVD or BD discs.

DISP – Switches between named station presets and radio frequencies.

CH +/- – Use to select channels for DVD/DVR units.

9 REMOTE SETUP

Use to input the preset code when making remote control settings and to set the remote control mode (page 67).

10 TV CTRL

Use this button to set preset code of your TV's manufacturer when controlling TV (see *Selecting preset codes directly* on page 67 for more on this).

11 MULTI-ZONE operation selector switch

Switch to perform operations in the main zone, ZONE 2 and ZONE 3 (page 64).

12 Remote control LED

Lights when a command is sent from the remote control (page 67).

13 SOURCE

Press to turn on/off other components connected to the receiver (see page 67 for more on this).

14 MASTER VOLUME +/-

Use to set the listening volume.

15 MUTE

Mutes the sound or restores the sound if it has been muted (adjusting the volume also restores the sound).

16 RECEIVER

Switches the remote to control the receiver (used to select the white commands above the number buttons (**A.ATT**, etc.)). Also use this button to set up surround sound.

17

Press to turn on/off the illumination of some of the buttons.

Front panel

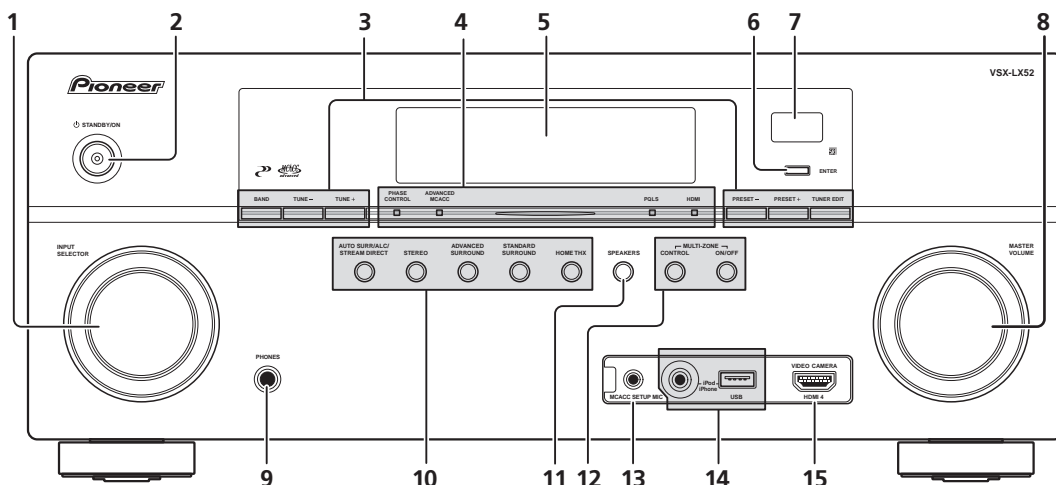

1 INPUT SELECTOR dial

Use to select an input function.

2 STANDBY/ON

Switches the receiver between on and standby. Power indicator lights when the receiver is on.

When the **KURO LINK** function is set to **ON**, the power indicator lights dimly when the power is in standby.

3 Tuner controls

BAND – Switches between AM and FM radio bands (page 48).

TUNE +/- – Use to find radio frequencies (page 48).

PRESET +/- – Use to find preset stations (page 48).

TUNER EDIT – Use with **TUNE +/-**, **PRESET +/-** and **ENTER** to memorize and name stations for recall (page 48).

4 PHASE CONTROL indicator – Lights to indicate Phase Control is selected (page 55).

ADVANCED MCACC indicator – Lights when **EQ** is set to **ON** in the **AUDIO PARAMETER** menu (page 60).

PQLS indicator – Lights when the PQLS feature is active (page 59).

HDMI indicator – Blinks when connecting an HDMI-equipped component; lights when the component is connected (page 23).

5 Character display

See *Display* on page 12.

6 ENTER

7 Remote sensor

Receives the signals from the remote control (see *Operating range of remote control unit* on page 8).

8 MASTER VOLUME dial

9 PHONES jack

Use to connect headphones. When the headphones are connected, there is no sound output from the speakers.

10 Listening mode buttons

AUTO SURR/ALC/STREAM DIRECT – Switches between Auto Surround (page 50), Auto level control mode and Stream Direct mode (page 53).

STEREO – Switches between stereo playback and Front Stage Surround Advance modes (page 52).

ADVANCED SURROUND – Use to switch between the various surround modes (page 51).

STANDARD SURROUND – Press for Standard decoding and to switch between the various Pro Logic IIx and Neo:6 options (page 50).

HOME THX – Press to select a Home THX listening mode (page 51).

11 SPEAKERS

Use to change the speaker system (page 63).

12 MULTI-ZONE controls

If you've made MULTI-ZONE connections (see *MULTI-ZONE setup* on page 31) use these controls to control the sub zone from the main zone (see *Using the MULTI-ZONE controls* on page 63).

13 MCACC SETUP MIC jack

Use to connect the supplied microphone (page 39).

14 iPod/iPhone/USB terminals

Use to connect your Apple iPod as an audio and video source, or connect a USB device for audio and photo playback (page 36).

15 HDMI input connector

Use for connection to compatible HDMI device (Video camera, etc.). See *Connecting an HDMI-equipped component to the front panel input* on page 35.

Display

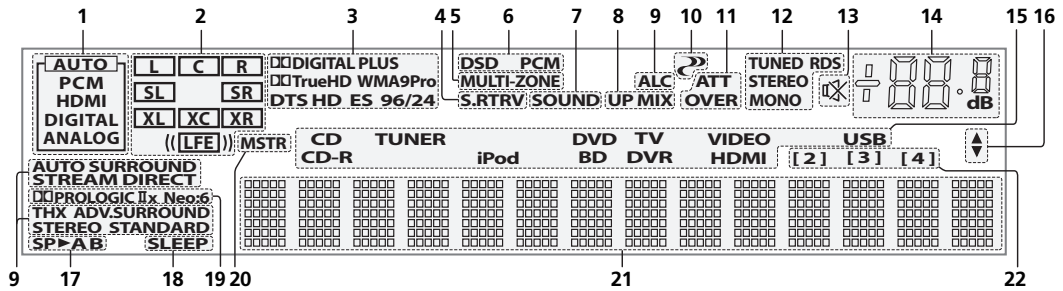

1 SIGNAL indicators

Light to indicate the currently selected input signal.

AUTO lights when the receiver is set to select the input signal automatically (page 55).

2 Program format indicators

Light to indicate the channels being input when PCM signals are being input. They do not indicate the audio signals being output from the receiver.

L/R – Left front/Right front channel

C – Center channel

SL/SR – Left surround/Right surround channel

LFE – Low frequency effects channel (the (()) indicators light when an LFE signal is being input)

XL/XR – Two channels other than the ones above

XC – Either one channel other than the ones above, the mono surround channel or matrix encode flag

3 Digital format indicators

Light when a signal encoded in the corresponding format is detected.

4 S.RTRV

Lights when the Sound Retriever function is active (page 60).

5 MULTI-ZONE

Lights when the MULTI-ZONE feature is active (page 63).

6 DSD PCM – Light during DSD (Direct Stream Digital) to PCM conversion with SACDs.

PCM – Lights during playback of PCM signals.

7 SOUND

Lights when any of the Midnight, Loudness or tone controls feature is selected (page 60).

Lights when Dialog Enhancement is switched on.

8 UP MIX

Lights when the Up Mix is switched on (page 54).

9 Listening mode indicators

AUTO SURROUND – Lights when the Auto Surround feature is switched on (page 50).

ALC – Lights when the ALC (Auto level control) mode is selected (page 53).

STREAM DIRECT – Lights when Direct/Pure Direct is selected (page 53).

ADV.SURROUND – Lights when one of the Advanced Surround modes has been selected (page 51).

STEREO – Lights when stereo listening is switched on (page 52).

STANDARD – Lights when one of the Standard Surround modes is switched on (page 50).

THX – Lights when one of the Home THX modes is selected (page 51).

10 (PHASE CONTROL)

Lights when the Phase Control is switched on (page 55).

11 Analog signal indicators

Light to indicate reducing the level of an analog signal (page 64).

12 Tuner indicators

TUNED – Lights when a broadcast is being received.

STEREO – Lights when a stereo FM broadcast is being received in auto stereo mode.

MONO – Lights when the mono mode is set using **MPX**.

RDS – Lights when an RDS broadcast is received.

13

Lights when the sound is muted (page 10).

14 Master volume level

Shows the overall volume level.

“---” indicates the minimum level, and “+12dB” indicates the maximum level.

15 Input function indicators

Light to indicate the input function you have selected.

16 Scroll indicators

Light when there are more selectable items when making the various settings.

17 Speaker indicators

Lights to indicate the current speaker system, **A** and/or **B** (page 63).

18 SLEEP

Lights when the receiver is in sleep mode (page 65).

19 Matrix decoding format indicators

PRO LOGIC IIx – This lights to indicate **PRO LOGIC II** / **PRO LOGIC IIx** decoding (page 50).

Neo:6 – When one of the Neo:6 modes of the receiver is on, this lights to indicate Neo:6 processing (page 50).

20 MSTR

Lights during playback of DTS-HD Master Audio signal.

21 Character display

Displays various system information.

22 Remote control mode indicator

Lights to indicate the receiver's remote control mode setting. (Not displayed when set to **1**.) (page 67)

Chapter 3:

Connecting your equipment

This receiver provides you with many connection possibilities, but it doesn't have to be difficult. This page explains the kinds of components you can connect to make up your home theater system.

Rear panel

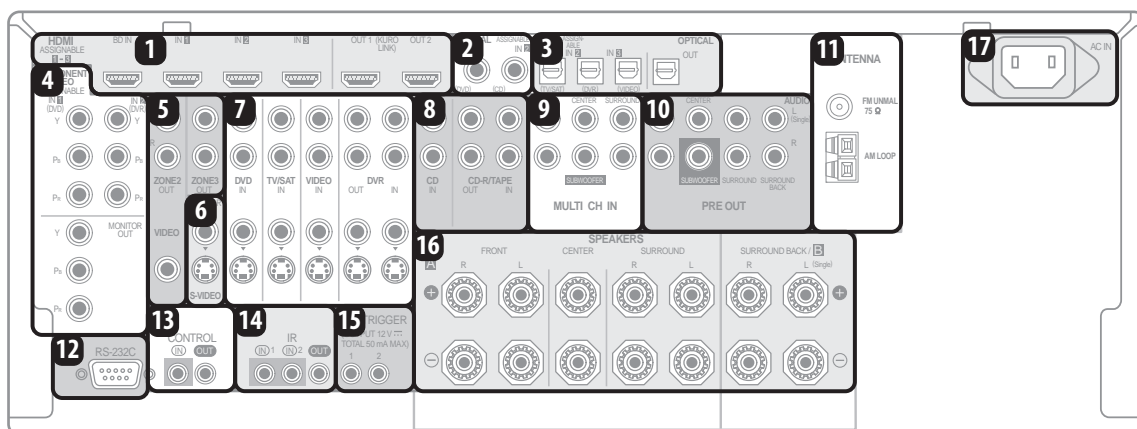

⚠ CAUTION

- Before making or changing the connections, switch off the power and disconnect the power cord from the power outlet. Plugging in should be the final step.
- To avoid hum, do not lay connected cables over the top of the receiver.

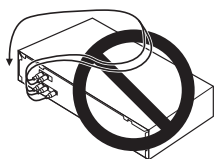

1 HDMI connectors (x6)

Multiple inputs and two outputs for high-quality audio/video connection to compatible HDMI devices.

→ See *Connecting your TV and playback components* on page 23.

→ See *Switching the HDMI output* on page 65.

2 Coaxial digital audio inputs (x2)

Use for digital audio sources, including DVD players/recorders, digital satellite receivers, CD players, etc.

→ See also *The Input Setup menu* on page 40 to assign the inputs.

3 Optical digital audio output/input(s) (x4)

Use the **OUT** jack for recording to a CD or MiniDisc recorder.

→ See *Connecting other audio components* on page 28.

Use the **IN** jacks for digital audio sources, including DVD players/recorders, digital satellite receivers, CD players, etc.

→ See also *The Input Setup menu* on page 40 to assign the inputs.

4 Component video connectors (x3)

Use the inputs to connect any video source that has component video output, such as a DVD player.

→ See *Connecting your DVD player with no HDMI output* on page 24.

Use the output to connect monitor or TV.

→ See *Connecting your TV with no HDMI input* on page 25.

5 MULTI-ZONE audio/video outputs

Use to connect a second or third amplifier and monitors or TVs in a separate room.

→ See *MULTI-ZONE setup* on page 31.

6 Composite and S-Video monitor outputs

Use to connect monitors and TVs.

→ See *Connecting your TV with no HDMI input* on page 25.

7 Audio/video source inputs/(outputs) (x5)

Use for connection to audio/visual sources, such as DVD players/recorders, VCRs, etc. Each set of inputs has jacks for composite video, S-Video and stereo analog audio.

→ See *Connecting an HDD/DVD recorder, VCR and other video sources* on page 27.

8 Stereo analog audio source inputs/(outputs) (x3)

Use for connection to audio sources such as CD players, tape decks, turntables, etc.

→ See *Connecting other audio components* on page 28.

9 Multichannel analog audio inputs

7.1 channel inputs for connection to a DVD player with multichannel analog outputs.

→ See *Connecting the multichannel analog inputs* on page 28.

10 Multichannel pre-amplifier outputs

Use to connect separate amplifiers for front, center, surround, surround back and subwoofer channels.

→ See *Connecting additional amplifiers* on page 29 (see also *Installing your speaker system* on page 19 for powered subwoofer connection).

11 AM and FM antenna terminals

Use to connect indoor or outdoor antennas for radio broadcasts.

→ See *Connecting AM/FM antennas* on page 30.

12 RS-232C connector

Use for connection to a PC for graphical output when using Advanced MCACC.

→ See *Connecting a PC for Advanced MCACC output* on page 34.

13 Control input/output

Use to connect other Pioneer components so that you can control all your equipment from a single IR remote sensor.

→ See *Operating other Pioneer components with this unit's sensor* on page 33.

14 Remote inputs/output

Use for connection to an external remote control sensor for use in a MULTI-ZONE setup, for example.

→ See *Connecting an IR receiver* on page 33.

15 12 V trigger jacks (total 50 mA max.) (x2)

Use to switch components in your system on and off according to the input function of the receiver.

→ See *Switching components on and off using the 12 volt trigger* on page 34.

16 Speaker terminals

Use for connection to the main front, center, surround and surround back speakers.

→ See *Connecting the speakers* on page 18.

17 AC power inlet

Connect the supplied power cord here.

→ See *Plugging in the receiver* on page 37.

Determining the speakers' application

Surround sound with a strong sense of presence can be enjoyed by connecting 7 speakers and 1 subwoofer. It is also possible to achieve high sound quality using bi-amp connections and to enjoy music in other rooms using the MULTI-ZONE feature. High sound quality can be achieved with a minimum of two speakers.

- Be sure to connect speakers to the front left and right channels (**L** and **R**).
- The **Surr Back System** setting must be made if you use any of the connections shown below other than [1] (see *Selecting the Surr Back system* on page 21).

[1] 7.1ch surround connection (Simple connection & Best surround)

**Default setting*

These connections prioritize surround sound with a speaker layout like that in a movie theater.

- **Surr Back System setting: Normal** (*default*)
- If you have six speakers, either only connect one surround back speaker (6.1 ch surround), or connect for the 7.1-channel setting as shown on the diagram below but without the center speaker.

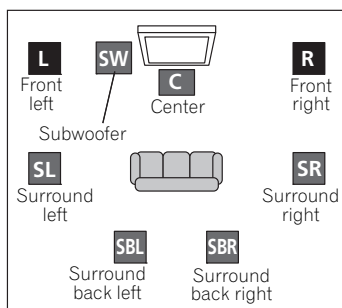

[2] 5.1ch surround & Front Bi-amping connection (High quality surround)

Bi-amping connection of the front speakers for high sound quality with 5.1-channel surround sound.

- **Surr Back System setting: Front Bi-Amp**

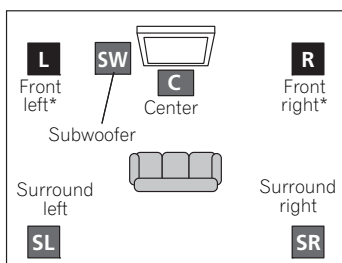

*Bi-amp compatible speaker

[3] 5.1ch surround & ZONE 2 connection (Multi Zone)

With these connections you can simultaneously enjoy 5.1-channel surround sound in the main zone with stereo playback on another component in ZONE 2. (The selection of input devices is limited.)

- **Surr Back System setting: ZONE 2**

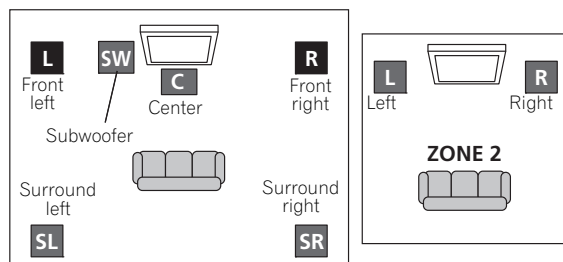

[4] 5.1ch surround & Speaker B connection

With these connections you can simultaneously enjoy 5.1-channel surround sound in the main zone with stereo playback of the same sound on the B speakers.

- **Surr Back System setting: Speaker B**

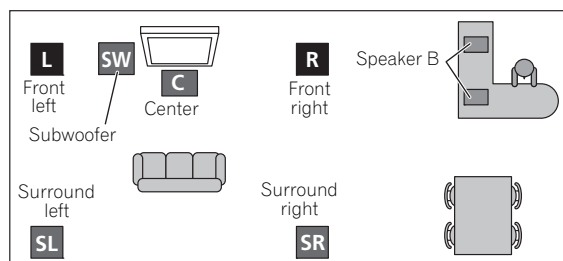

Other speaker connection

- Your favorite speaker connections can be selected even if you have fewer than 5.1 speakers.
- When not connecting a subwoofer, connect speakers with low frequency reproduction capabilities to the front channel. (The subwoofer's low frequency component is played from the front speakers, so the speakers could be damaged.)
- **After connecting, be sure to conduct the Auto MCACC (speaker environment setting) procedure.** See *Automatically setting up for surround sound (Auto MCACC)* on page 39.

Placing the speakers

To achieve the best possible surround sound, install your speakers as shown below.

5.1 channel surround system:

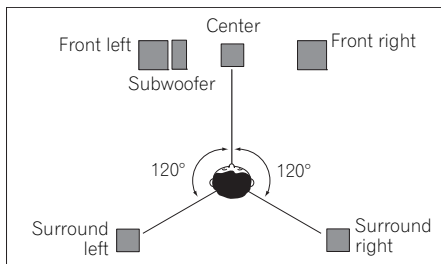

6.1 channel surround system:

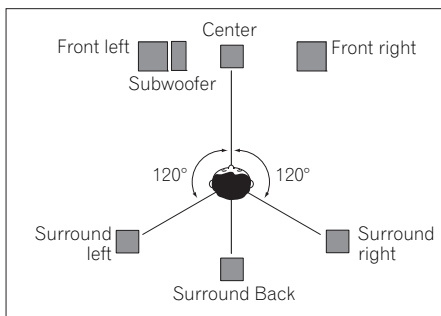

7.1 channel surround system:

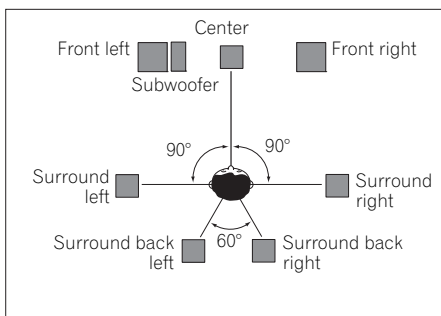

- If you have two surround back speakers THX recommends placing them together and the same distance from your listening position (see below).

THX speaker system setup

If you have a complete THX speaker system, follow the diagram below to place your speakers. Note that the surround speakers (⊞ indicates bi-polar radiating speakers) should output at an angle parallel to the listener.

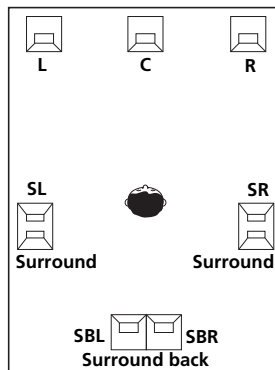

- If you have two surround back speakers THX recommends placing them together and the same distance from your listening position for the following THX modes: **THX Select2 CINEMA**, **THX Select2 MUSIC** and **THX Select2 GAMES**.
- If you are using a THX certified subwoofer use the **THX INPUT** jack on the subwoofer (if your subwoofer has one) or switch the filter position to **THX** on your subwoofer.

See also *THX Audio Setting* on page 87 to make the settings that will give you the best sound experience when using the Home THX modes (page 51).

Some tips for improving sound quality

Where you put your speakers in the room has a big effect on the quality of the sound. The following guidelines should help you to get the best sound from your system.

- The subwoofer can be placed on the floor. Ideally, the other speakers should be at about ear-level when you're listening to them. Putting the speakers on the floor (except the subwoofer), or mounting them very high on a wall is not recommended.
- For the best stereo effect, place the front speakers 2 m to 3 m apart, at equal distance from the TV.
- If you're using a center speaker, place the front speakers at a wider angle. If not, place them at a narrower angle.
- Place the center speaker above or below the TV so that the sound of the center channel is localized at the TV screen. Also, make sure the center speaker does not cross the line formed by the leading edge of the front left and right speakers.
- It is best to angle the speakers towards the listening position. The angle depends on the size of the room. Use less of an angle for bigger rooms.
- Surround and surround back speakers should be positioned 60 cm to 90 cm higher than your ears and tilted slight downward. Make sure the speakers don't face each other. For DVD-Audio, the speakers should be more directly behind the listener than for home theater playback.
- If the surround speakers cannot be set directly to the side of the listening position with a 7.1-channel system, the surround effect can be enhanced by turning off the Up Mix function (see *Setting the Up Mix function* on page 54).
- Try not to place the surround speakers farther away from the listening position than the front and center speakers. Doing so can weaken the surround sound effect.

Connecting the speakers

Each speaker connection on the receiver comprises a positive (+) and negative (-) terminal. Make sure to match these up with the terminals on the speakers themselves.

⚠ CAUTION

- These speaker terminals carry **HAZARDOUS LIVE voltage**. To prevent the risk of electric shock when connecting or disconnecting the speaker cables, disconnect the power cord before touching any uninsulated parts.
- Make sure that all the bare speaker wire is twisted together and inserted fully into the speaker terminal. If any of the bare speaker wire touches the back panel it may cause the power to cut off as a safety measure.

Bare wire connections

- 1 **Twist exposed wire strands together.** (*fig. A*)
- 2 **Loosen terminal and insert exposed wire.** (*fig. B*)
- 3 **Tighten terminal.** (*fig. C*)

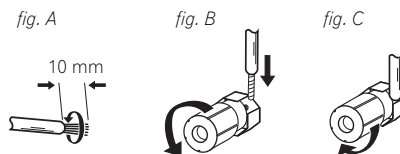

👉 Important

- Please refer to the manual that came with your speakers for details on how to connect the other end of the speaker cables to your speakers.
- Use an RCA cable to connect the subwoofer. It is not possible to connect using speaker cables.

⚠ CAUTION

- Make sure that all speakers are securely installed. This not only improves sound quality, but also reduces the risk of damage or injury resulting from speakers being knocked over or falling in the event of external shocks such as earthquakes.

Installing your speaker system

At the very least, front left and right speakers only are necessary. Note that your main surround speakers should always be connected as a pair, but you can connect just one surround back speaker if you like (it must be connected to the left surround back terminal).

Standard 5.1/6.1/7.1-channel surround connections

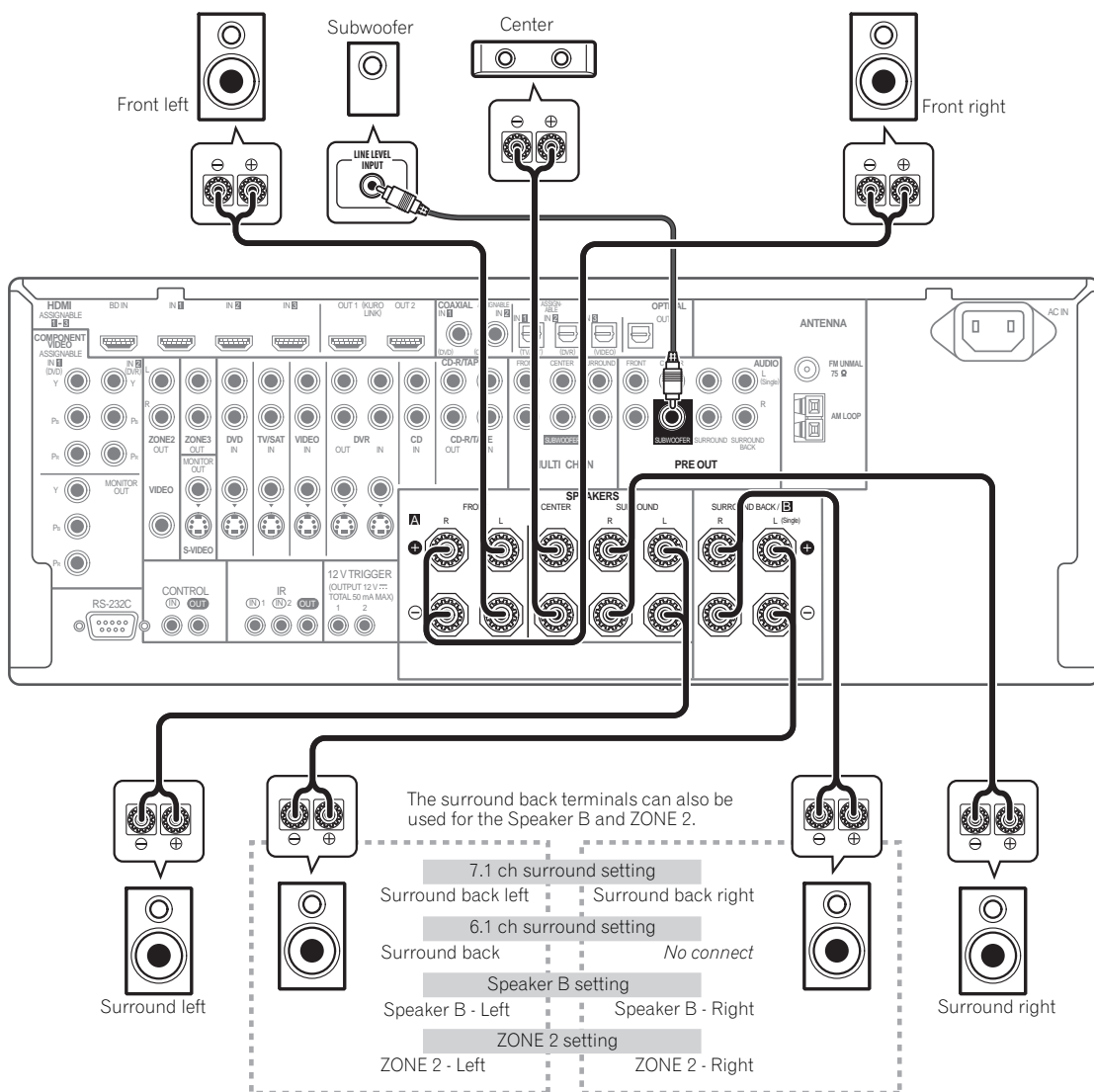

Bi-amping your speakers

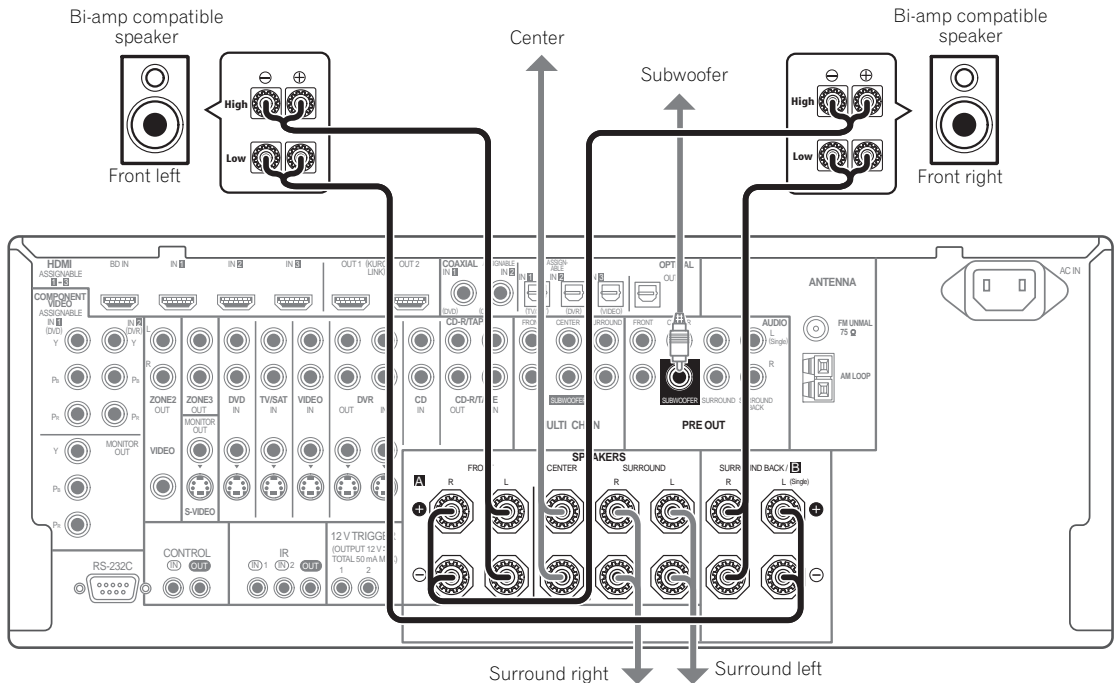

Bi-amping is when you connect the high frequency driver and low frequency driver of your speakers to different amplifiers for better crossover performance. Your speakers must be bi-ampable to do this (having separate terminals for high and low) and the sound improvement will depend on the kind of speakers you're using.

⚠ CAUTION

- Most speakers with both **High** and **Low** terminals have two metal plates that connect the **High** to the **Low** terminals. These must be removed when you are bi-amping the speakers or you could severely damage the amplifier. See your speaker manual for more information.
- If your speakers have a removable crossover network, make sure you do not remove it for bi-amping. Doing so may damage your speakers.

Bi-wiring your speakers

Your speakers can also be bi-wired if they support bi-amping.

- With these connections, the **Surr Back System** setting makes no difference.
- **To bi-wire a speaker, connect two speaker cords to the speaker terminal on the receiver.**

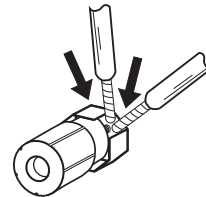

⚠ CAUTION

- Don't connect different speakers from the same terminal in this way.
- When bi-wiring as well, heed the cautions for bi-amping shown at the left.

Selecting the Surr Back system

The surround back terminals can be used for bi-amping, Speaker B and ZONE 2 connections, in addition to for the surround back speakers. Make this setting according to the application.

ZONE 2 setup

With these connections you can simultaneously enjoy 5.1-channel surround sound in the main zone with stereo playback on another component in ZONE 2.

1 Connect a pair of speakers to the surround back speaker terminals.

See *Standard 5.1/6.1/7.1-channel surround connections* on page 19.

2 Select 'ZONE 2' from the Surr Back System menu.

See *Surround back speaker setting* on page 85 to do this.

Speaker B setup

You can listen to stereo playback in another room.

1 Connect a pair of speakers to the surround back speaker terminals.

See *Standard 5.1/6.1/7.1-channel surround connections* on page 19.

2 Select 'Speaker B' from the Surr Back System menu.

See *Surround back speaker setting* on page 85 to do this.

Bi-Amping setup

Bi-amping connection of the front speakers for high sound quality with 5.1-channel surround sound.

1 Connect a Bi-amp compatible speakers to the front and surround back speaker terminals.



See *Bi-amping your speakers* on page 20.

2 Select 'Front Bi-Amp' from the Surr Back System menu.

See *Surround back speaker setting* on page 85 to do this.

About the audio connection

There are several types of audio input and output terminals on this receiver. The receiver selects the first available signal in the following order:

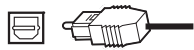
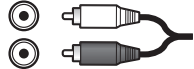
	Types of cables and terminals	Transferable audio signals
↑ Sound signal priority	HDMI 	HD audio
	Digital (Coaxial)  Digital (Optical) 	Conventional digital audio
	RCA (Analog) (White/Red) 	Conventional analog audio

- With an HDMI cable, video and audio signals can be transferred in high quality over a single cable.

CAUTION

- When connecting optical cables, be careful when inserting the plug not to damage the shutter protecting the optical socket.
- When storing optical cable, coil loosely. The cable may be damaged if bent around sharp corners.

About the video converter

The video converter ensures that all video sources are output through all of the **MONITOR VIDEO OUT** jacks. The only exception is HDMI: since this resolution cannot be downsampled, you must connect your monitor/TV to the receiver's HDMI video outputs when connecting this video source.¹

If several video components are assigned to the same input function (see *The Input Setup menu* on page 40), the converter gives priority to HDMI, component, S-Video, then composite (in that order).

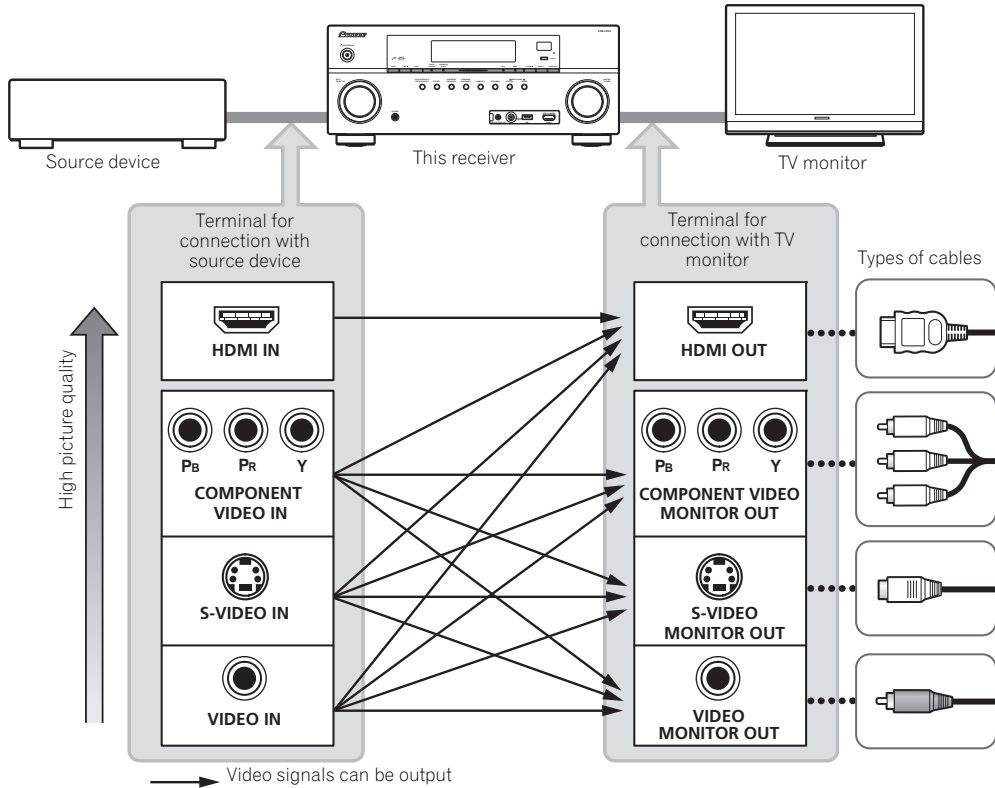

- For optimal video performance, THX recommends switching Digital Video Conversion (in *Setting the Video options* on page 61) **OFF**.

This product incorporates copyright protection technology that is protected by method claims of certain U.S. patents and other intellectual property rights owned by Macrovision Corporation and other rights owners. Use of this copyright protection technology must be authorized by Macrovision Corporation, and is intended for home and other limited viewing uses only unless otherwise authorized by Macrovision Corporation. Reverse engineering or disassembly is prohibited.

Note

- 1 • If the video signal does not appear on your TV or flat screen TV, try adjusting the resolution settings on your component or display. Note that some components (such as video game units) have resolutions that may not be converted. In this case, try switching Digital Video Conversion (in *Setting the Video options* on page 61) **OFF**.
 - The signal input resolutions that can be converted from the component video input for the HDMI output are 480i/576i, 480p/576p, 720p and 1080i. 1080p signals cannot be converted.
 - Only signals with an input resolution of 480i/576i can be converted from the component video input for the composite monitor output.

Connecting your TV and playback components

Connecting using HDMI

If you have an HDMI or DVI (with HDCP) equipped component (Blu-ray disc player, etc.), you can connect it to this receiver using a commercially available HDMI cable.

If the TV and playback components support the Pioneer KURO LINK feature, the convenient KURO LINK functions can be used (see *KURO LINK* on page 57).

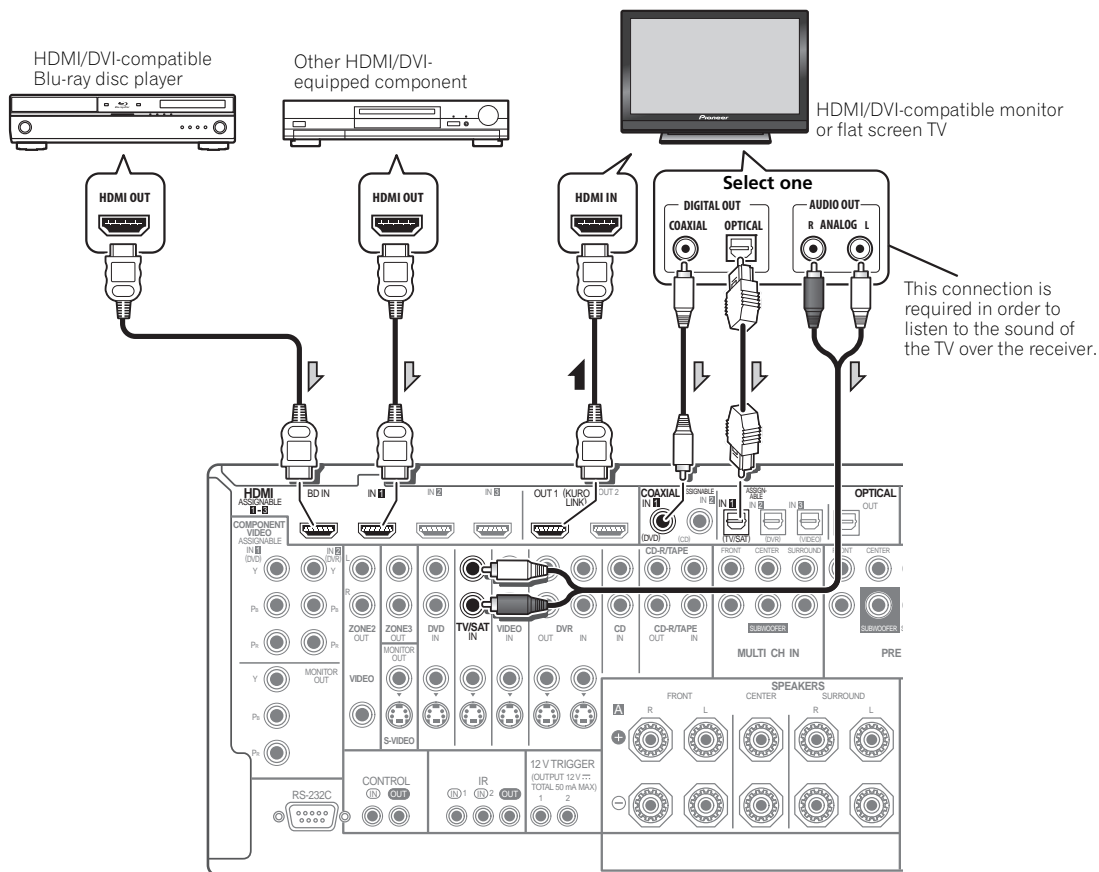

- When connecting a Blu-ray disc player, connect the player to the receiver's **BD IN** terminal.
- When connecting to an HDMI/DVI-compatible monitor or a flat screen TV using the **HDMI OUT 2** terminal, switch the HDMI output setting to **HDMI OUT 2** or **HDMI OUT ALL**. See *Switching the HDMI output* on page 65.
- The **HDMI** indicator lights on the front panel when an HDMI-equipped component is connected.
- For input components, connections other than HDMI connections are also possible (see *Connecting your DVD player with no HDMI output* on page 24).
- If your Blu-ray disc player offers multi-channel analog audio outputs, see *Connecting the multichannel analog inputs* on page 28.
- The sound of the TV cannot be heard over the receiver if the TV is connected using an HDMI cable. If you want to listen to the sound of the TV over the receiver, connect the receiver and TV with audio cables.

Connecting your DVD player with no HDMI output

This diagram shows connections of a TV (with HDMI input) and DVD player (or other playback component with no HDMI output) to the receiver.

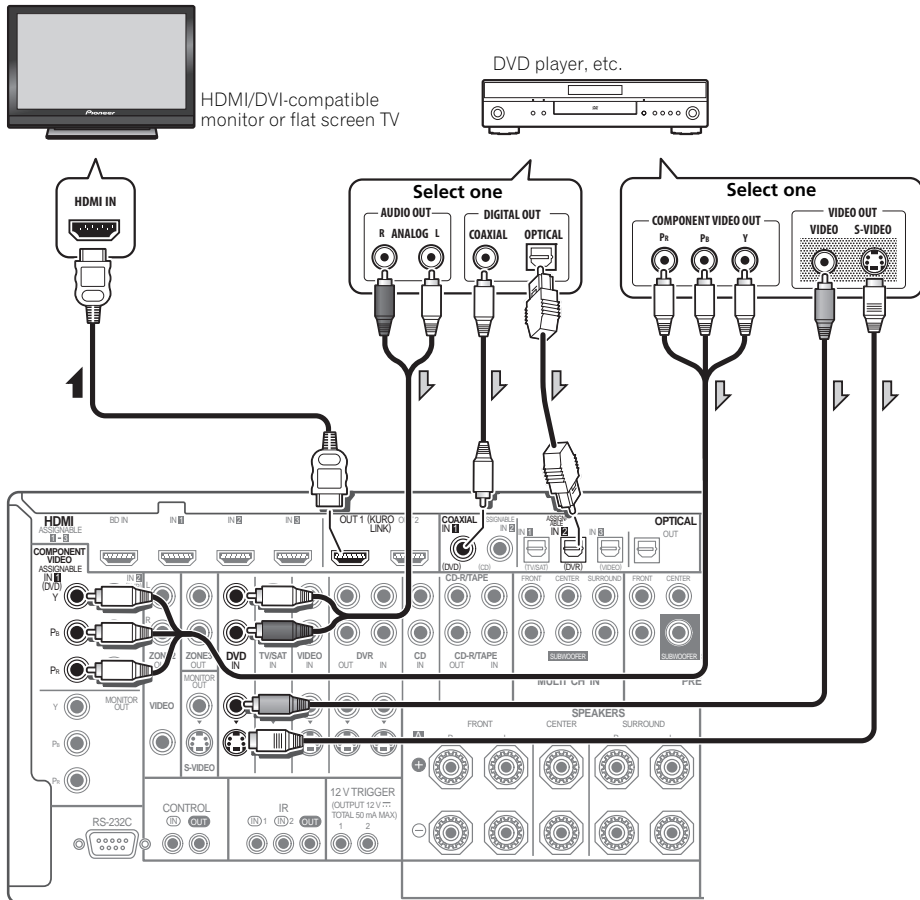

- If you want to listen to the sound of the TV over the receiver, connect the receiver and TV with audio cables.
- Component video should give superior picture quality when compared to composite. You can also take advantage of progressive scan video (if your source and TV are both compatible), which delivers a very stable, flicker-free picture. See the manuals that came with your TV and source component to check whether they are compatible with progressive-scan video.

Connecting your TV with no HDMI input

This diagram shows connections of a TV (with no HDMI input) and DVD player (or other playback component) to the receiver.

- With these connections, the picture is not output to the TV even if the DVD player is connected with an HDMI cable. Connect the DVD player's video signals using a composite or component cord.

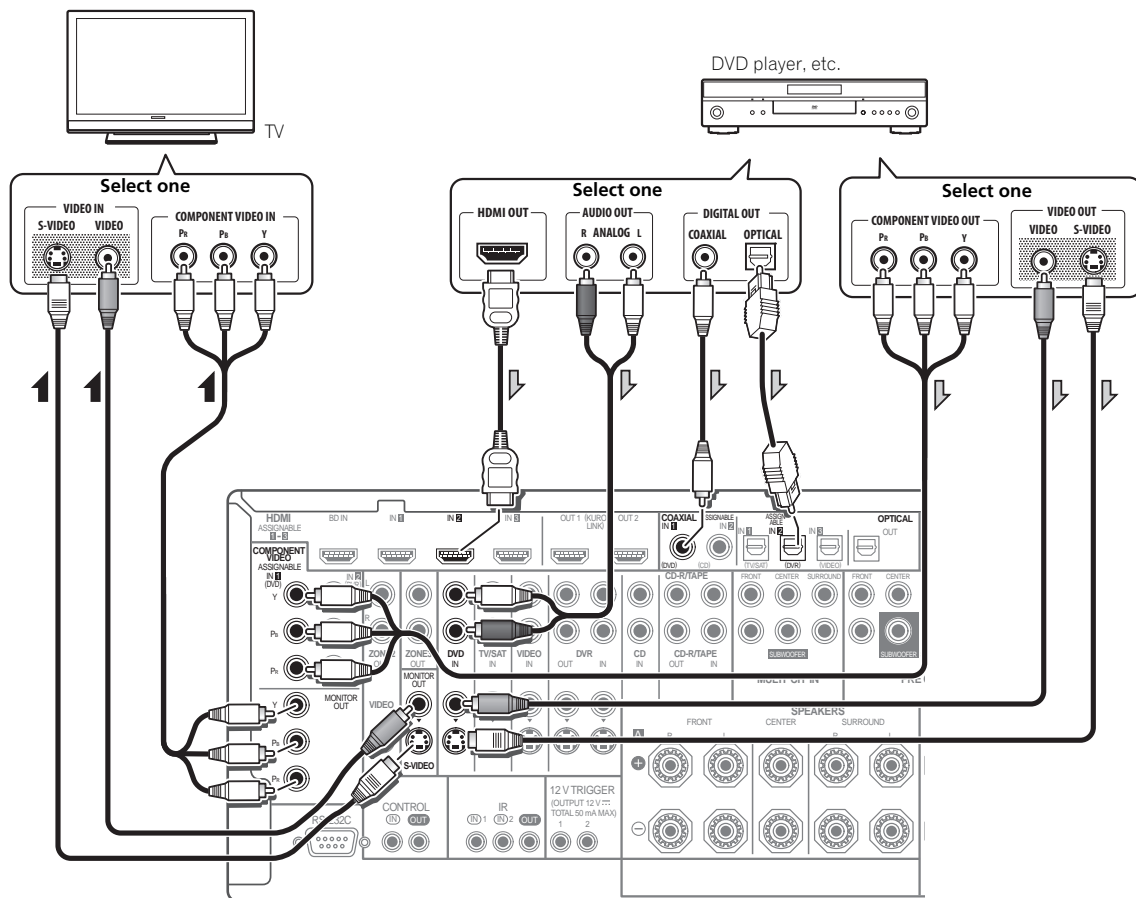

- Connect using an HDMI cable to listen to HD audio on the receiver. Do not use an HDMI cable to input video signals. Depending on the video component, it may not be possible to output signals connected by HDMI and other methods simultaneously, and it may be necessary to make output settings. Please refer to the operating instructions supplied with your component for more information.
- Component video should give superior picture quality when compared to composite. You can also take advantage of progressive scan video (if your source and TV are both compatible), which delivers a very stable, flicker-free picture. See the manuals that came with your TV and source component to check whether they are compatible with progressive-scan video.
- If your DVD player has multichannel analog outputs, you can connect these instead. See also *Connecting the multichannel analog inputs* on page 28.

- The input functions below are assigned by default to the receiver's different input terminals. Refer to *The Input Setup menu* on page 40 to change the assignments if other connections are used. For example, the BD terminal is fixed to **BD** input; no other audio signals can be input to this terminal.

Input function	Input Terminals		
	Digital	HDMI	Component
DVD	COAX-1		IN 1
BD		(BD)	
TV/SAT	OPT-1		
DVR	OPT-2		IN 2
VIDEO	OPT-3		
HDMI 1		(HDMI-1)	
HDMI 2		(HDMI-2)	
HDMI 3		(HDMI-3)	
HDMI 4 (front panel)		(HDMI-4)	
CD	COAX-2		

About HDMI¹

The HDMI connection transfers uncompressed digital video, as well as almost every kind of digital audio that the connected component is compatible with, including DVD-Video, DVD-Audio, SACD, Dolby Digital Plus, Dolby TrueHD, DTS-HD Master Audio (see below for limitations), Video CD/Super VCD and CD. See *About the video converter* on page 22 for more on HDMI compatibility.

This receiver incorporates High-Definition Multimedia Interface (HDMI™) technology.

This receiver supports the functions described below through HDMI connections.

- Digital transfer of uncompressed video (contents protected by HDCP (1080p/24, 1080p/60, etc.))
- DeepColor signal transfer²
- x.v.Color signal transfer²
- Input of multi-channel linear PCM digital audio signals (192 kHz or less) for up to 8 channels
- Input of the following digital audio formats:
 - Dolby Digital, Dolby Digital Plus, DTS, High bitrate audio (Dolby TrueHD, DTS-HD Master Audio), DVD-Audio, CD, SACD (DSD signal), Video CD, Super VCD
- Synchronized operation with components using the KURO LINK function (see *KURO LINK* on page 57)

HDMI, the HDMI logo and High-Definition Multimedia Interface are trademarks or registered trademarks of HDMI Licensing, LLC.

"x.v.Color" and x.v.Color logo are trademarks of Sony Corporation.

Note

- An HDMI connection can only be made with DVI-equipped components compatible with both DVI and High Bandwidth Digital Content Protection (HDCP). If you choose to connect to a DVI connector, you will need a separate adaptor (DVI→HDMI) to do so. A DVI connection, however, does not support audio signals. Consult your local audio dealer for more information.
 - If you connect a component that is not compatible with HDCP, an **HDCP ERROR** message is displayed on the front panel display. Some components that are compatible with HDCP still cause this message to be displayed, but so long as there is no problem with displaying video this is not a malfunction.
 - Depending on the component you have connected, using a DVI connection may result in unreliable signal transfers.
 - This receiver supports SACD, Dolby Digital Plus, Dolby TrueHD and DTS-HD Master Audio. To take advantage of these formats, however, make sure that the component connected to this receiver also supports the corresponding format.
- Signal transfer is only possible when connected to a compatible component.

Connecting an HDD/DVD recorder, VCR and other video sources

This receiver has two sets of audio/video inputs and outputs suitable for connecting analog or digital video devices, including HDD/DVD recorders and VCRs.

When you set up the receiver you'll need to tell the receiver which input you connected the recorder to (see also *The Input Setup menu* on page 40).

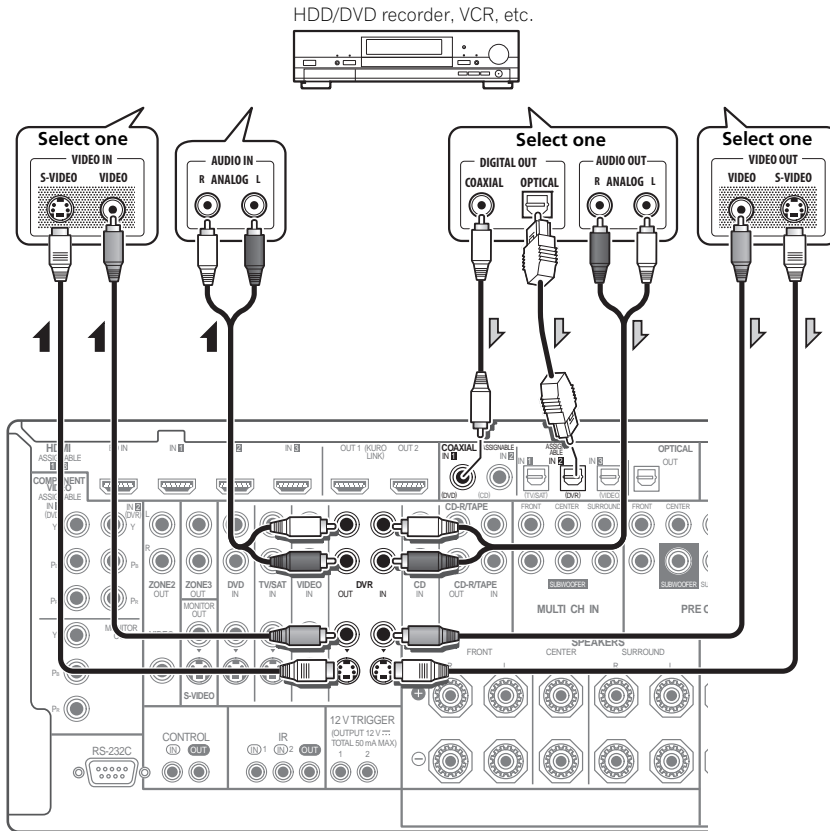

Connecting a satellite/cable receiver or other set-top box

Satellite and cable receivers, and terrestrial digital TV tuners are all examples of so-called 'set-top boxes'.

When you set up the receiver you'll need to tell the receiver which input you connected the set-top box to (see *The Input Setup menu* on page 40).

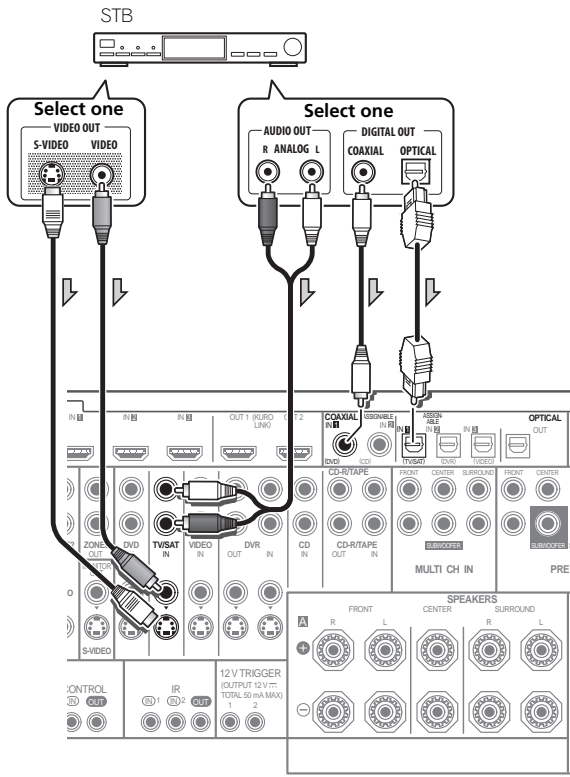

Connecting the multichannel analog inputs

For DVD Audio and SACD playback, your DVD player may have 5.1 channel analog outputs. Make sure that the player is set to output multichannel analog audio.

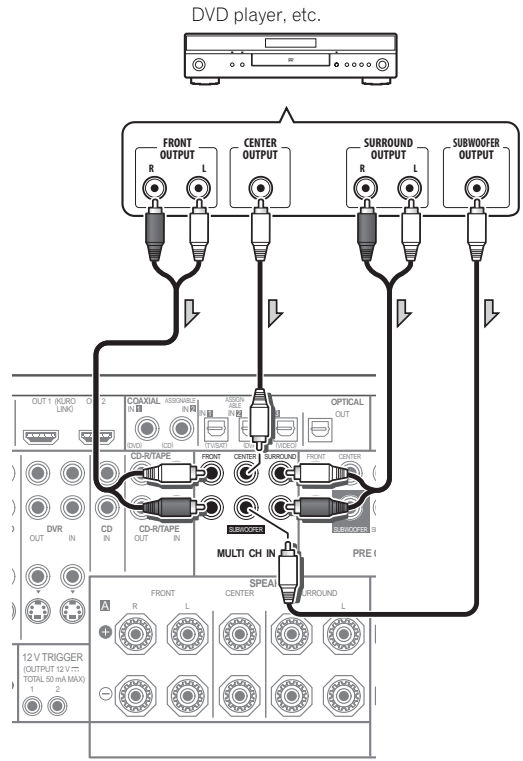

- If your player has 7.1-channel analog outputs, the player's surround back output terminals are not used. Please refer to the operating instructions supplied with your component for more information.

Connecting other audio components

This receiver has both digital and analog inputs, allowing you to connect audio components for playback.

This receiver features five stereo audio-only inputs. One of these inputs have corresponding outputs for use with audio recorders.

Most digital components also have analog connections.

When you set up the receiver you'll need to tell the receiver which input you connected the component to (see also *The Input Setup menu* on page 40).

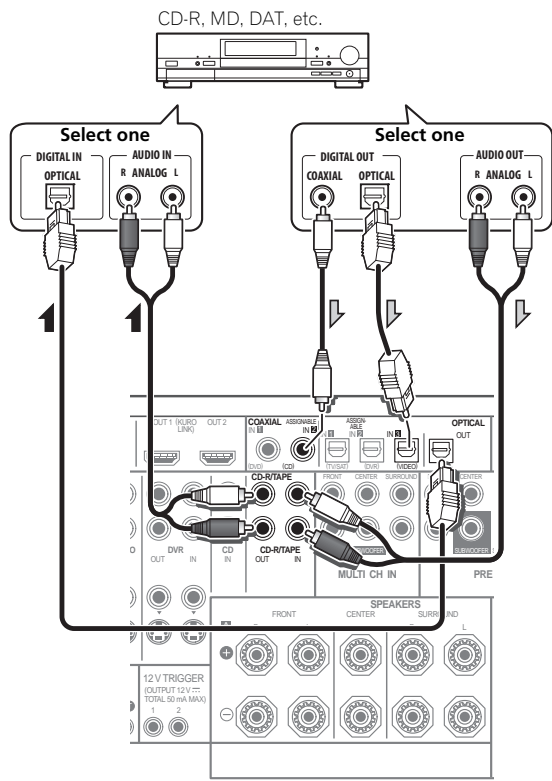

- If your turntable has line-level outputs (i.e., it has a built-in phono pre-amp), connect it to the **CD** inputs instead.
- If you're connecting a recorder, connect the analog audio outputs to the analog audio inputs on the recorder.

About the WMA9 Pro decoder

This unit has an on-board Windows Media™ Audio 9 Professional¹ (WMA9 Pro) decoder, so it is possible to playback WMA9 Pro-encoded audio using HDMI, coaxial or optical digital connection when connected to a WMA9 Pro-compatible player. However, the connected DVD player, set-top box, etc. must be able to output WMA9 Pro format audio signals through a coaxial or optical digital output.

Note

- 1 • Windows Media and the Windows logo are trademarks or registered trademarks of Microsoft Corporation in the United States and/or other countries.
- With WMA9 Pro, sound problems may occur depending on your computer system. Note that WMA9 Pro 96 kHz sources will be downsampled to 48 kHz.

Connecting additional amplifiers

This receiver has more than enough power for any home use, but it's possible to add additional amplifiers to every channel of your system using the pre-outs. Make the connections shown below to add amplifiers to power your speakers.

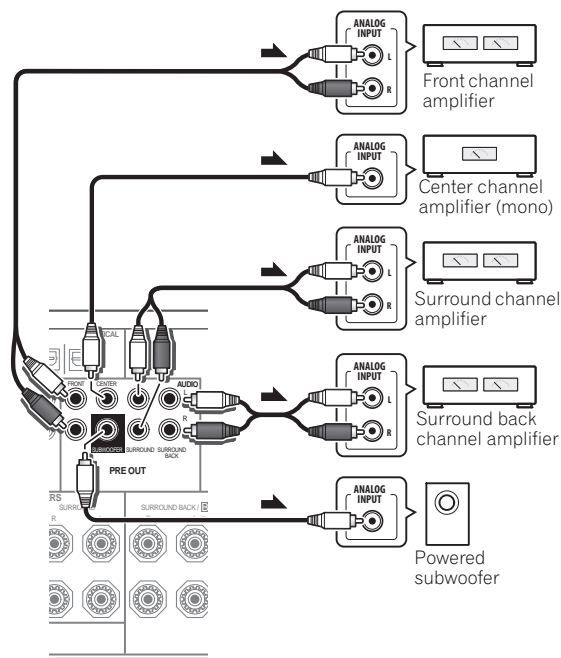

- You can use the additional amplifier on the surround back channel pre-outs for a single speaker as well. In this case plug the amplifier into the left (**L (Single)**) terminal only.
- The sound from the surround back terminals will depend on how you have configured the *Surround back speaker setting* on page 85.
- To hear sound only from the pre-outs, switch the speaker system to **OFF**, or simply disconnect any speakers that are connected directly to the receiver.

If you're not using a subwoofer, change the front speaker setting (see *Speaker Setting* on page 85) to **LARGE**.

Connecting AM/FM antennas

Connect the AM loop antenna and the FM wire antenna as shown below. To improve reception and sound quality, connect external antennas (see *Connecting external antennas* below).

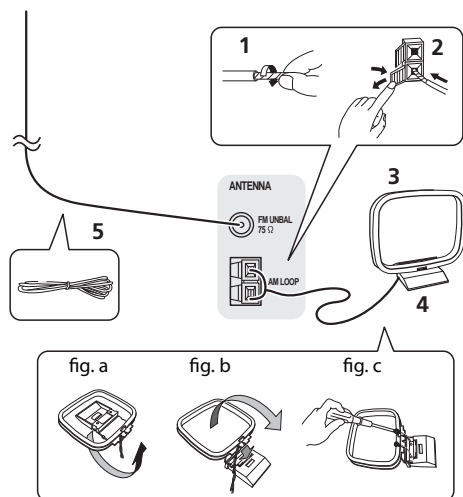

1 Pull off the protective shields of both AM antenna wires.

2 Push open the tabs, then insert one wire fully into each terminal, then release the tabs to secure the AM antenna wires.

3 Fix the AM loop antenna to the attached stand.

To fix the stand to the antenna, bend in the direction indicated by the arrow (*fig. a*) then clip the loop onto the stand (*fig. b*).

- If you plan to mount the AM antenna to a wall or other surface, secure the stand with screws (*fig. c*) before clipping the loop to the stand. Make sure the reception is clear.

4 Place the AM antenna on a flat surface and in a direction giving the best reception.

5 Connect the FM wire antenna in the same way as the AM loop antenna.

For best results, extend the FM antenna fully and fix to a wall or door frame. Don't drape loosely or leave coiled up.

Connecting external antennas

To improve FM reception connect an external FM antenna to the **FM UNBAL 75 Ω**.

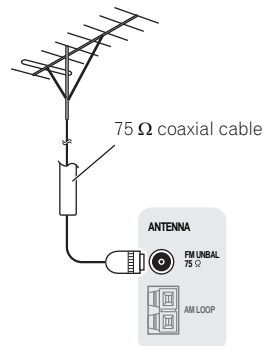

To improve AM reception, connect a 5 m to 6 m length of vinyl-coated wire to the **AM LOOP** terminals without disconnecting the supplied AM loop antenna.

For the best possible reception, suspend horizontally outdoors.

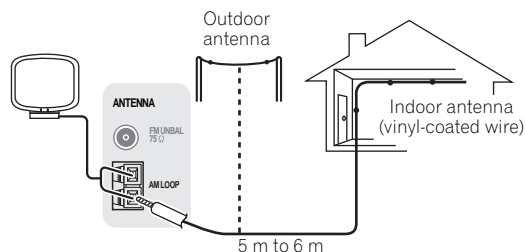

MULTI-ZONE setup

This receiver can power up to three independent systems in separate rooms after you have made the proper MULTI-ZONE connections. An example MULTI-ZONE setup is shown below, but the number of MULTI-ZONE connections (and the way you choose to connect them) depends on how you want to set up your system.

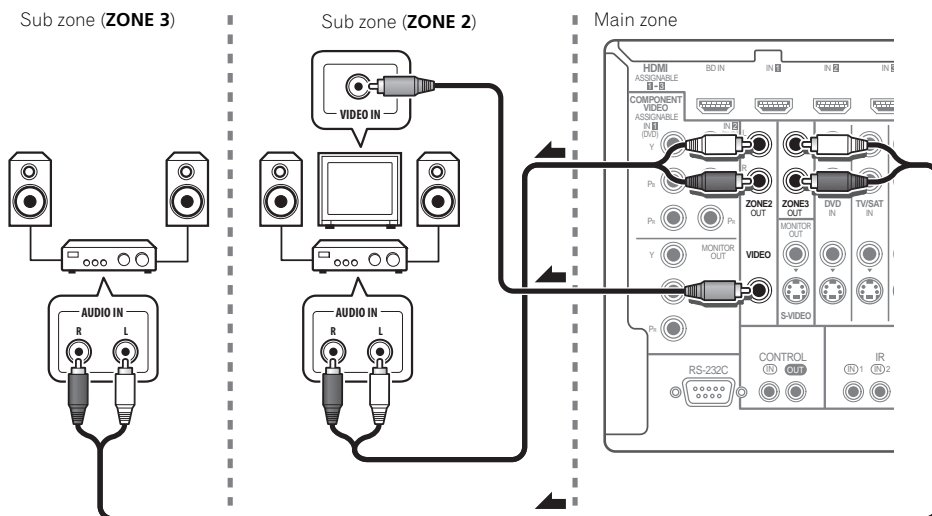

Different sources can be playing in three zones at the same time or, depending on your needs, the same source can also be used. The main and sub zones have independent power (the main zone power can be off while one (or both) of the sub zones is on) and the sub zones can be controlled by the remote or front panel controls. However, you may need to specify the volume settings in *ZONE Audio Setup* on page 89.

Making MULTI-ZONE connections

It is possible to make these connections if you have a separate TV and speakers for your primary (**ZONE 2**) sub zone, and a separate amplifier¹ (and speakers) for your secondary (**ZONE 3**) sub zone. You will also need a separate amplifier if you are not using the *MULTI-ZONE setup using speaker terminals (ZONE 2)* on page 32 for your primary sub zone. There are two primary sub zone setups possible with this system. Choose whichever works best for you.

MULTI-ZONE listening options

The following table shows the signals that can be output to ZONE 2 and ZONE 3:

Sub Zone	Input functions available
ZONE 2	Analog audio signals (AUDIO ZONE 2 OUT). ^a With video signals, ^b the composite video (VIDEO ZONE 2 OUT) signals can be output.
ZONE 3	Analog audio signals (AUDIO ZONE 3 OUT). ^{a,c}

a. Any analog signal. (This does not apply for the MULTI CH IN input.)

b. JPEG files cannot be played with the USB input.

c. iPod/USB function cannot be selected for ZONE 3.

Note

¹ You can't use sound controls (such as the tone controls or Midnight listening) or any surround modes with a separate amplifier in the sub zone. You can, however, use the features available with your sub zone amplifier.

Basic MULTI-ZONE setup (ZONE 2)

- Connect a separate amplifier to the **AUDIO ZONE 2 OUT** jacks and a TV monitor to the **VIDEO ZONE 2 OUT** jack, both on this receiver.

You should have a pair of speakers attached to the sub zone amplifier as shown in the following illustration.

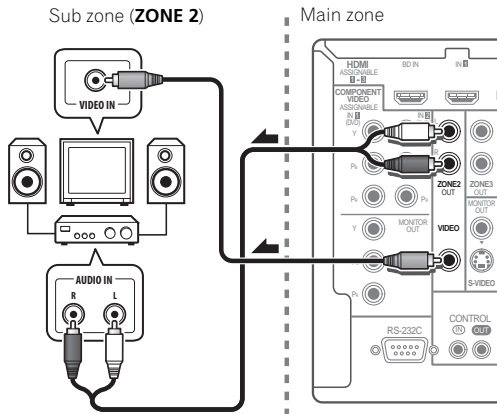

Secondary MULTI-ZONE setup (ZONE 3)

- Connect a separate amplifier to the **AUDIO ZONE 3 OUT** jacks on this receiver.

You should have a pair of speakers attached to the sub zone amplifier as shown in the following illustration.

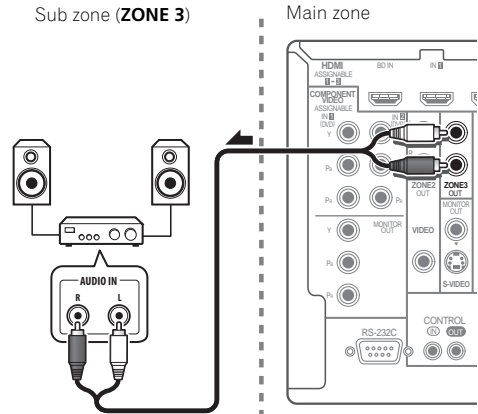

MULTI-ZONE setup using speaker terminals (ZONE 2)

You must select **ZONE 2** in *Surround back speaker setting* on page 85 to use this setup. Note that the sound in the sub zone will be temporarily interrupted when controlling the main zone (for example, changing the input function or starting playback).

- Connect a TV monitor to the **VIDEO ZONE 2 OUT** jacks on this receiver.

You should have a pair of speakers attached to the surround back speaker terminals as shown below.

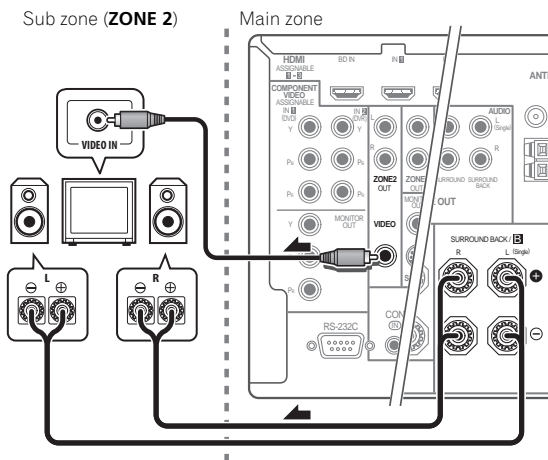

Connecting an IR receiver

If you keep your stereo components in a closed cabinet or shelving unit, or you wish to use the sub zone remote control in another zone, you can use an optional IR receiver (such as a Niles or Xantech unit) to control your system instead of the remote sensor on the front panel of this receiver.¹

1 Connect the IR receiver sensor to the IR IN jack on the rear of this receiver.

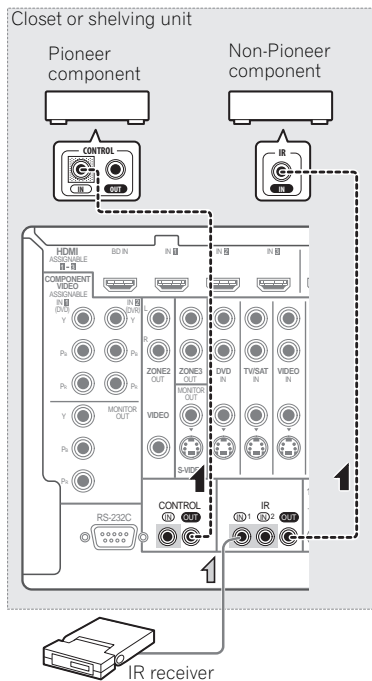

2 Connect the IR IN jack of another component to the IR OUT jack on the rear of this receiver to link it to the IR receiver.

Please see the manual supplied with your IR receiver for the type of cable necessary for the connection.

- If you want to link a Pioneer component to the IR receiver, see *Operating other Pioneer components with this unit's sensor* below to connect to the **CONTROL** jacks instead of the **IR OUT** jack.

Operating other Pioneer components with this unit's sensor

Many Pioneer components have **SR CONTROL** jacks which can be used to link components together so that you can use just the remote sensor of one component. When you use a remote control, the control signal is passed along the chain to the appropriate component.²

Important

- Note that if you use this feature, *make sure that you also have at least one set of analog audio, video or HDMI jacks connected to another component for grounding purposes.*

1 Decide which component you want to use the remote sensor of.

When you want to control any component in the chain, this is the remote sensor at which you'll point the corresponding remote control.

2 Connect the CONTROL OUT jack of that component to the CONTROL IN jack of another Pioneer component.

Use a cable with a mono mini-plug on each end for the connection.

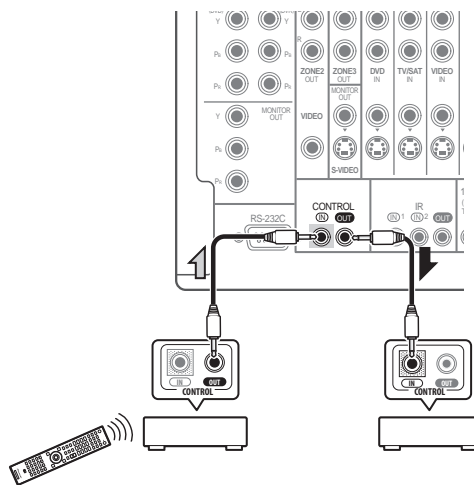

Continue the chain in the same way for as many components as you have.

Note

- Remote operation may not be possible if direct light from a strong fluorescent lamp is shining on the IR receiver remote sensor window.
 - Note that other manufacturers may not use the IR terminology. Refer to the manual that came with your component to check for IR compatibility.
 - If using two remote controls (at the same time), the IR receiver's remote sensor takes priority over the remote sensor on the front panel.
- If you want to control all your components using this receiver's remote control, see *Setting the remote to control other components* on page 67.
 - If you have connected a remote control to the **CONTROL IN** jack (using a mini-plug cable), you won't be able to control this unit using the remote sensor.

Switching components on and off using the 12 volt trigger

You can connect components in your system (such as a screen or projector) to this receiver so that they switch on or off using 12 volt triggers when you select an input function. However, you must specify which input functions switch on the trigger using the *The Input Setup menu* on page 40. Note that this will only work with components that have a standby mode.¹

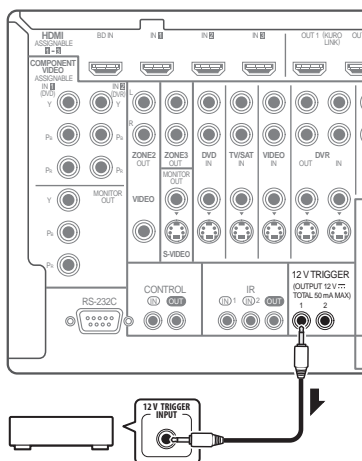

- **Connect the 12 V TRIGGER jack of this receiver to the 12 V trigger of another component.**

Use a cable with a mono mini-plug on each end for the connection.

- The trigger maximum power is DC OUT 12 V/50 mA.

After you've specified the input functions that will switch on the trigger, you'll be able to switch the component on or off just by pressing the input function(s) you've set on page 40.

Connecting a PC for Advanced MCACC output

When using Auto MCACC (page 72) or Acoustic Calibration EQ Professional (page 77) to calibrate the reverb characteristics of your listening room, the 3D graphs of the reverb characteristics in your listening room (before and after calibration) can be checked on a computer screen by connecting the receiver to the computer and using a special application to transfer the data. The various MCACC parameters can also be checked on the computer.

Use a commercially-available RS-232C cable to connect the RS-232C jack on your computer to the 9-pin RS-232C jack on the back panel of this receiver (the cable must be cross type, female-female).

The software to output the results is available from the support area of the Pioneer website (<http://www.pioneer.eu>). Instructions for using the software are also available here. If you have any questions about the software, please contact the Pioneer Service Center specified on your warranty card.

Please make sure your system meets the following requirements:

- The computer must be a PC functioning with one of the following operating systems: Microsoft® Windows® Vista Home Basic/Home Premium/Ultimate SP1, Windows® XP Professional/Home Edition SP3 or Windows® 2000 Professional SP4.
- The monitor must have a display resolution of 800 x 600 dots (SVGA) or greater.
- The computer must be equipped with at least one RS-232C port.²
- System must have internet access.

Microsoft®, Windows® Vista, Windows® XP and Windows® 2000 are either registered trademarks or trademarks of Microsoft Corporation in the United States and/or other countries.

Note

¹ Triggered connections with up to two devices compatible with 12-volt triggers can be made with this receiver.

² Laptops and other computers not equipped with an RS-232C port can be connected via USB port using a commercially available USB to RS-232C converter cable (USB to serial converter cable). For instructions on COM port connections and settings, contact the manufacturer of your computer.

- **Connect your computer to the RS-232C jack on the rear panel of the receiver.**

Make sure that the receiver and all connected components are switched off and disconnected from the power outlet when you do this.¹

Use a commercially-available cable to connect the RS-232C jack on your computer to the 9-pin RS-232C jack on this receiver. See the documentation provided with the Advanced MCACC application for more information.

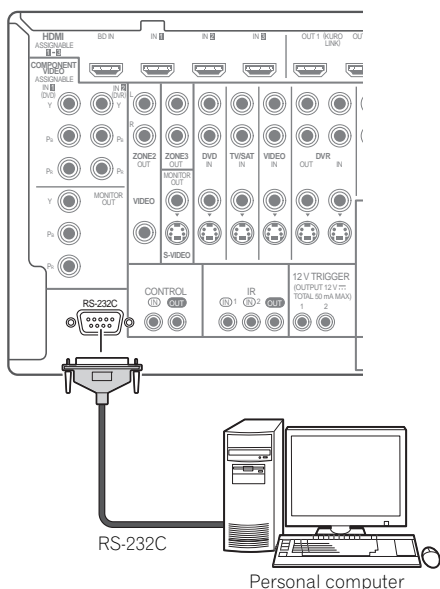

Connecting an HDMI-equipped component to the front panel input

There is an HDMI input terminal on the front panel. High quality pictures can be viewed via the receiver simply by connecting an HDMI-equipped video camera with a single HDMI cable. HDMI-equipped components other than video cameras can also be connected to this terminal.

- Push down on the **PUSH OPEN** tab to access the front panel input.
- Select this input using **INPUT SELECT** (remote) or the **INPUT SELECTOR** dial (front panel) to select **HDMI 4**.

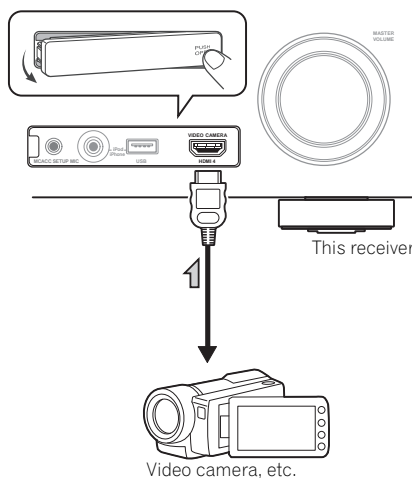

Note

¹ The various parameters and the reverb characteristics data used for display on the computer are not cleared when the power is turned off (see *Output PC* on page 81).

Connecting an iPod

This receiver has a dedicated iPod terminal that will allow you to control playback of audio content from your iPod using the controls of this receiver.

- **Switch the receiver into standby then use the supplied iPod cable to connect your iPod to the iPod/iPhone/USB terminal on the front panel of this receiver.**
 - Push down on the **PUSH OPEN** tab to access the **iPod/iPhone/USB** terminal.
 - It is also possible to connect using the cable included with the iPod, but in this case it is not possible to view pictures via the receiver.
 - For the cable connection, refer to also the operating instructions for iPod.
 - For instructions on playing the iPod, see *Playing an iPod* on page 43.

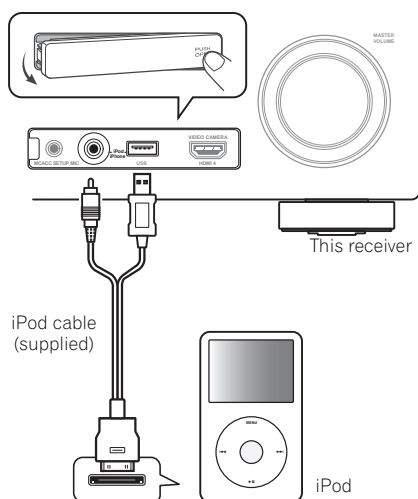

Connecting a USB device

It is possible to playback files using the USB interface on the front of this receiver.

- **Switch the receiver into standby then connect your USB device to the USB terminal on the front panel of this receiver.**
 - Push down on the **PUSH OPEN** tab to access the **USB** terminal.
 - For instructions on playing the USB device, see *Playing a USB device* on page 45.

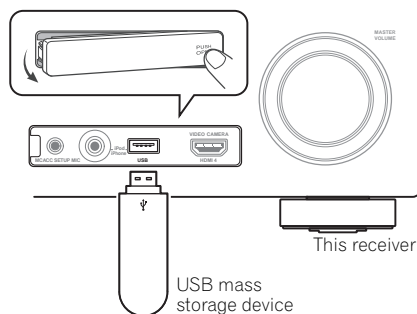

Plugging in the receiver

Only plug in after you have connected all your components to this receiver, including the speakers.

- 1 Plug the supplied power cord into the AC IN socket on the back of the receiver.
- 2 Plug the other end into a power outlet.¹

CAUTION

- Handle the power cord by the plug part. Do not pull out the plug by tugging the cord, and never touch the power cord when your hands are wet, as this could cause a short circuit or electric shock. Do not place the unit, a piece of furniture, or other object on the power cord or pinch the cord in any other way. Never make a knot in the cord or tie it with other cables. The power cords should be routed so that they are not likely to be stepped on. A damaged power cord can cause a fire or give you an electric shock. Check the power cord once in a while. If you find it damaged, ask your nearest Pioneer authorized independent service company for a replacement.
- Do not use any power cord other than the one supplied with this unit.
- Do not use the supplied power cord for any purpose other than that described below.
- The receiver should be disconnected by removing the mains plug from the wall socket when not in regular use, e.g., when on vacation.
- Make sure the blue  **STANDBY/ON** light has gone out before unplugging.
- If you have connected speakers with a 6 Ω impedance, change the impedance setting before turning on the power.

Note

¹ After this receiver is connected to an AC outlet, a 2 second to 10 second HDMI initialization process begins. You cannot carry out any operations during this process. The **HDMI** indicator in the front panel display blinks during this process, and you can turn on this receiver once it has stopped blinking. When you set the **KURO LINK** mode to **OFF**, you can skip this process. For details about the **KURO LINK** feature, see *KURO LINK* on page 57.

Chapter 4: Basic Setup

Switching the speaker impedance

We recommend using speakers of 8 Ω with this system, but it is possible to switch the impedance setting if you plan to use speakers with a 6 Ω impedance rating.

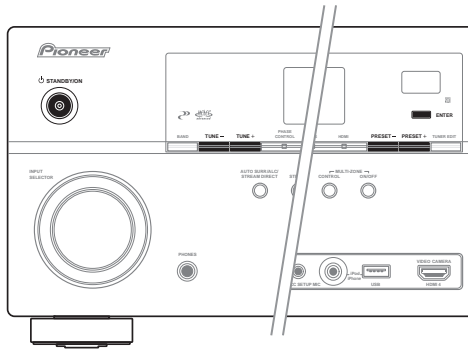

- 1 Switch the receiver into standby.
- 2 While holding down ENTER on the front panel, press **STANDBY/ON**.
The display shows **RESET ◀ NO ▶**.
Use **TUNE +/-** (or **↑/↓** on the remote control) to select **SPEAKER ◀ 8Ω ▶**, and then use **PRESET +/-** (or **←/→** on the remote control) to select **SPEAKER 8Ω** or **SPEAKER 6Ω**.
 - **SPEAKER 8Ω** – Use this setting if your speakers are rated at 8 Ω or more.
 - **SPEAKER 6Ω** – Use this setting if your speakers are rated at 6 Ω.

Changing the OSD display language (OSD Language)

The language used on the Graphical User Interface screen can be changed.

- The explanations in these operating instructions are for when English is selected for the GUI screen.

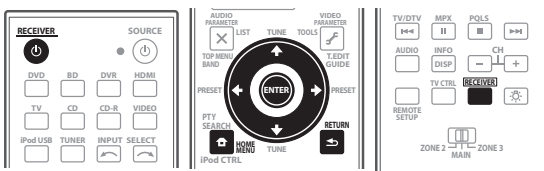

- 1 Switch on the receiver and your TV.

Use **RECEIVER** to switch on.

- 2 Press **RECEIVER** on the remote control, then press **HOME MENU**.

A Graphical User Interface (GUI) screen appears on your TV. Use **↑/↓/←/→** and **ENTER** to navigate through the screens and select menu items. Press **RETURN** to exit the current menu.

- 3 Select 'System Setup' from the HOME MENU.
- 4 Select 'OSD Language' from the System Setup menu.

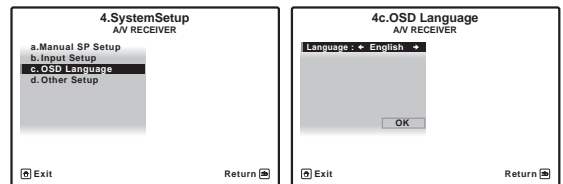

- 5 Select the desired language.
 - English
 - French
 - German
 - Italian
 - Spanish
 - Dutch
 - Russian
- 6 Select 'OK' to change the language.

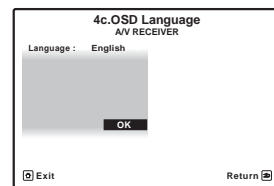

The setting is completed and the **System Setup** menu reappears automatically.

Automatically setting up for surround sound (Auto MCACC)

The Auto MCACC Setup measures the acoustic characteristics of your listening area, taking into account ambient noise, speaker connection and speaker size, and tests for both channel delay and channel level. After you have set up the microphone provided with your system, the receiver uses the information from a series of test tones to optimize the speaker settings and equalization for your particular room.

Make sure you do this before moving on to *Playing a source* on page 42.

Important

- Make sure the microphone and speakers are not moved during the Auto MCACC Setup.
- Using the Auto MCACC Setup will overwrite any existing settings for the MCACC preset you select.
- Before using the Auto MCACC Setup, the headphones should be disconnected and the iPod/USB function should not be selected as an input function.

CAUTION

- The test tones used in the Auto MCACC Setup are output at high volume.

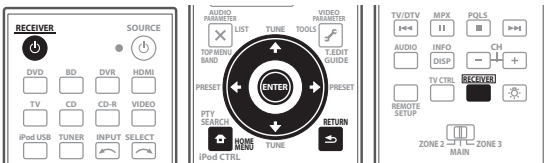

1 Switch on the receiver and your TV.

Use **RECEIVER** to switch on.

2 Connect the microphone to the MCACC SETUP MIC jack on the front panel.

- Push down on the **PUSH OPEN** tab to access the **MCACC SETUP MIC** jack.

Make sure there are no obstacles between the speakers and the microphone.

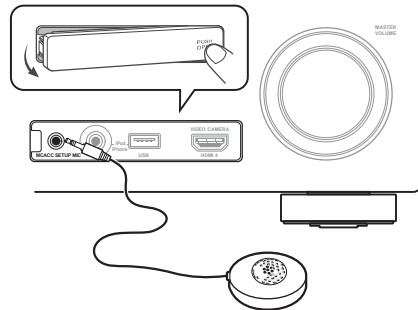

If you have a tripod, use it to place the microphone so that it's about ear level at your normal listening position. If you do not have a tripod, use some other object to install the microphone.¹

The Full Auto MCACC display appears once the microphone is connected.²

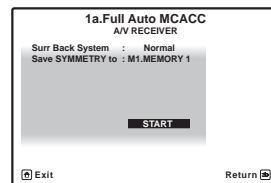

3 Select Surr Back System setting,³ select an MCACC preset⁴, press **RECEIVER and then select **START**.⁵ Select **Normal** (Surround back), **Speaker B, Front Bi-Amp** or **ZONE 2** for the **Surr Back System** setting according to connections to the surround back speaker terminals.**

4 Follow the instructions on-screen.

Make sure the microphone is connected, and if you're using a subwoofer, make sure it is switched on and set to a comfortable volume level.

Note

- 1 It may not be possible to measure correctly if the microphone is placed on a table, sofa, etc.
- 2 • You can't use the **HOME MENU** when the iPod/USB input function is selected (in either the main or sub zone). When you set **ZONE 2, ZONE 3** or **ZONE 2&3** to **ON** (page 63), you can't use the **HOME MENU**.
 - If you leave the GUI screen for over five minutes, the screen saver will appear.
- 3 • If you are planning on bi-amping your front speakers, or setting up a separate speaker system in another room, read through *Surround back speaker setting* on page 85 and make sure to connect your speakers as necessary before continuing to step 4.
 - If you have THX-certified speakers, select **Return**, then select **Auto MCACC** for the THX Speaker setting. See *Automatic MCACC (Expert)* on page 72 for more on this.
- 4 The six MCACC presets are used for storing surround sound settings for different listening positions. Simply choose an unused preset for now (you can rename it later in *Data Management* on page 82).
- 5 Note that correction curves are saved only when set to **SYMMETRY**. Select **Return**, then select **Auto MCACC** to save other correction curves (such as **ALL CH ADJ** and **FRONT ALIGN**). See *Automatic MCACC (Expert)* on page 72 for more on this.

5 Wait for the test tones to finish, then confirm the speaker configuration in the GUI screen.

A progress report is displayed on-screen while the receiver outputs test tones to determine the speakers present in your setup. Try to be as quiet as possible while it's doing this.¹

If no operations are performed for 10 seconds while the speaker configuration check screen is being displayed, the Auto MCACC Setup will resume automatically. In this case, you don't need to select 'OK' and press ENTER in step 6.

- With error messages (such as **Too much ambient noise!** or **Check microphone.**) select **RETRY** after checking for ambient noise (see *Problems when using the Auto MCACC Setup* below) and verifying the mic connection. If there doesn't seem to be a problem, you can simply select **GO NEXT** and continue.

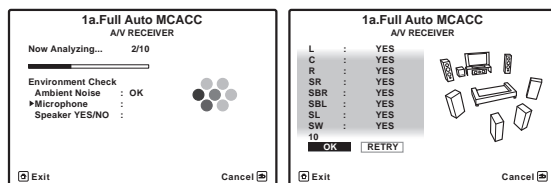

The configuration shown on-screen should reflect the actual speakers you have.

- If you see an **ERR** message (or the speaker configuration displayed isn't correct), there may be a problem with the speaker connection. If selecting **RETRY** doesn't work, turn off the power and check the speaker connections. If there doesn't seem to be a problem, you can simply use **↑/↓** to select the speaker and **←/→** to change the setting and continue.
- If **Reverse Phase** is displayed, the speaker's wiring (+ and -) may be inverted. Check the speaker connections.²
 - If the connections were wrong, turn off the power, disconnect the power cord, then reconnect properly. After this, perform the Full Auto MCACC procedure again.
 - If the connections were right, select **GO NEXT** and continue.

6 Make sure 'OK' is selected, then press ENTER.

A progress report is displayed on-screen while the receiver outputs more test tones to determine the optimum receiver settings for Channel Level, Speaker Distance, Standing Wave and Acoustic Cal EQ.

Again, try to be as quiet as possible while this is happening. It may take 3 to 10 minutes.

7 The Auto MCACC Setup procedure is completed and the Home Menu menu reappears automatically.³

Be sure to disconnect the microphone from this receiver upon completion of the Auto MCACC Setup.

The settings made in the Auto MCACC Setup should give you excellent surround sound from your system, but it is also possible to adjust these settings manually using *The Advanced MCACC menu* on page 71 or *The system and the other setup* on page 84.⁴

Problems when using the Auto MCACC Setup

If the room environment is not optimal for the Auto MCACC Setup (too much background noise, echo off the walls, obstacles blocking the speakers from the microphone) the final settings may be incorrect. Check for household appliances (air conditioner, fridge, fan, etc.), that may be affecting the environment and switch them off if necessary. If there are any instructions showing in the front panel display, please follow them.

- Some older TVs may interfere with the operation of the microphone. If this seems to be happening, switch off the TV when doing the Auto MCACC Setup.

The Input Setup menu

You only need to make settings in the **Input Setup** menu if you didn't hook up your digital equipment according to the default settings (see *Input function default and possible settings* on page 41). In this case, you need to tell the receiver what equipment is hooked up to which terminal so the buttons on the remote control correspond to the components you've connected.

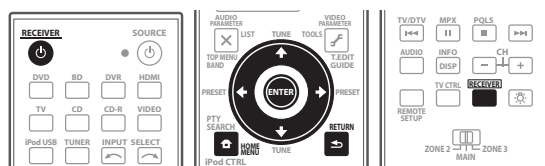

Note

- 1 Do not adjust the volume during the test tones. This may result in incorrect speaker settings.
- 2 If the speaker is not pointed to the microphone (listening position) or when using speakers that affect the phase (dipole speakers, reflective speakers, etc.), **Reverse Phase** may be displayed even if the speakers are properly connected.
- 3 You can also choose to view the settings from the **MCACC Data Check** screen. See *Checking MCACC Data* on page 80 for more on this.
- 4 Depending on the characteristics of your room, sometimes identical speakers with cone sizes of around 12 cm will end up with different size settings. You can correct the setting manually using the *Manual speaker setup* on page 84.
 - The subwoofer distance setting may be farther than the actual distance from the listening position. This setting should be accurate (taking delay and room characteristics into account) and generally does not need to be changed.
 - If Auto MCACC Setup measurement results are incorrect due to the interaction of the speakers and viewing environment, we recommend adjusting the settings manually.

1 Switch on the receiver and your TV.

Use **RECEIVER** to switch on.

2 Press **RECEIVER on the remote control, then press **HOME MENU**.**

A Graphical User Interface (GUI) screen appears on your TV. Use **↑/↓/←/→** and **ENTER** to navigate through the screens and select menu items. Press **RETURN** to confirm and exit the current menu.

3 Select 'System Setup' from the HOME MENU.

4 Select 'Input Setup' from the System Setup menu.

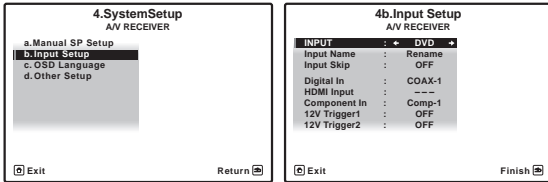

5 Select the input function that you want to set up.

The default names correspond with the names next to the terminals on the rear panel (such as **DVD** or **VIDEO**) which, in turn, correspond with the names on the remote control.

6 Select the input(s) to which you've connected your component.

For example, if your DVD player only has an optical output, you will need to change the **DVD** input function's **Digital In** setting from **COAX-1** (default) to the optical input you've connected it to. The numbering (**OPT-1** to **3**) corresponds with the numbers beside the inputs on the back of the receiver.

- If your component is connected via a component video cable to an input terminal other than the default, you must tell the receiver which input terminal your component is connected to, or else you may see the S-Video or composite video signals instead of the component video signals.¹

7 When you're finished, proceed to the settings for other inputs.

There are three optional settings in addition to the assignment of the input jacks:

- **Input Name** – You can choose to rename the input function for easier identification. Select **Rename** to do so, or **Default** to return to the system default.
- **Input Skip** – When set to **ON**, that input is skipped when selecting the input using **INPUT SELECT**. (**DVD** and other inputs can be still be selected directly with the input function buttons.)

- **12V Trigger1/2** – After connecting a component to one of the 12 volt triggers (see *Switching components on and off using the 12 volt trigger* on page 34), select **MAIN, ZONE 2, ZONE 3** or **OFF** for the corresponding trigger setting to switch it on automatically along with the (main or sub) zone specified.

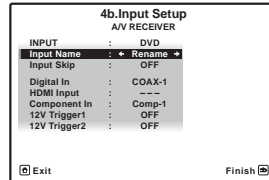

8 When you're finished, press RETURN.

You will return to the **System Setup** menu.

Input function default and possible settings

The terminals on the receiver generally correspond to the name of one of the input functions. If you have connected components to this receiver differently from (or in addition to) the defaults below, see *The Input Setup menu* on page 40 to tell the receiver how you've connected up. The dots (●) indicate possible assignments.

Input function	Input Terminals		
	Digital	HDMI	Component
DVD	COAX-1	● ^a	IN 1
BD		(BD) ^b	
TV/SAT	OPT-1	● ^a	●
DVR	OPT-2	● ^a	IN 2
VIDEO	OPT-3	● ^a	●
HDMI 1		(HDMI-1)	
HDMI 2		(HDMI-2)	
HDMI 3		(HDMI-3)	
HDMI 4		(HDMI-4) ^b	
iPod/USB			
CD	COAX-2		
CD-R/TAPE	●		
TUNER			
MULTI CH IN		● ^a	

a. With **KURO LINK** set to **ON**, assignments cannot be made (see *KURO LINK* on page 57).

b. This assignment is fixed and cannot be changed.

Note

¹ For high-definition video (using component video connections), or when digital video conversion is switched off (in *Setting the Video options* on page 61), you must connect your TV to this receiver using the same type of video cable as you used to connect your video component.

Chapter 5: Basic playback

Playing a source

Here are the basic instructions for playing a source (such as a DVD disc) with your home theater system.

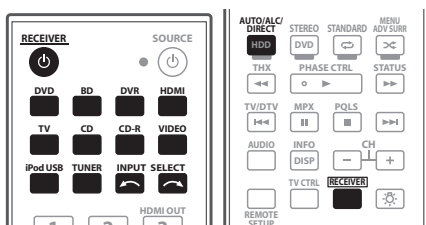

1 Switch on your system components and receiver.

Start by switching on the playback component (for example a DVD player), your TV¹ and subwoofer (if you have one), then the receiver (press **RECEIVER**).

- Make sure the setup microphone is disconnected.

2 Select the input function you want to play.

You can use the input function buttons on the remote control, **INPUT SELECT**, or the front panel **INPUT SELECTOR** dial.²

3 Press **RECEIVER**, then press **AUTO/ALC/DIRECT (AUTO SURR/ALC/STREAM DIRECT)** to select 'AUTO SURROUND' and start playback of the source.³

If you're playing a Dolby Digital or DTS surround sound DVD disc, you should hear surround sound. If you are playing a stereo source, you will only hear sound from the front left/right speakers in the default listening mode.

- See also *Listening to your system* on page 50 for information on different ways of listening to sources.

It is possible to check on the front panel display whether or not multi-channel playback is being performed properly.

When using a surround back speaker, **DOD+PLIIx MOVIE** is displayed when playing Dolby Digital signals, and **DTS+Neo:6** is displayed when playing DTS 5.1-channel signals.

When not using a surround back speaker, **DOLBY DIGITAL** is displayed when playing Dolby Digital signals. If the display does not correspond to the input signal and listening mode, check the connections and settings.

4 Use the volume control to adjust the volume level.

Turn down the volume of your TV so that all sound is coming from the speakers connected to this receiver.

Playing a source with HDMI connection

- Use **INPUT SELECT** to select the HDMI input you've connected to (for example, **HDMI 1**).

You can also perform the same operation by using the **INPUT SELECTOR** dial on the front panel or by pressing **HDMI** on the remote control repeatedly.

- Set the HDMI parameter in *Setting the Audio options* on page 60 to **THROUGH** if you want to hear HDMI audio output from your TV or flat screen TV (no sound will be heard from this receiver).
- If the video signal does not appear on your TV or flat screen TV, try adjusting the resolution settings on your component or display. Note that some components (such as video game units) have resolutions that may not be converted. In this case, use an analog video connection.
- You can't hear HDMI audio through this receiver's digital out jack.

Note

¹ Make sure that the TV's video input is set to this receiver (for example, if you connected this receiver to the **VIDEO** jacks on your TV, make sure that the **VIDEO** input is now selected).

² If you need to manually switch the input signal type press **SIGNAL SEL** (page 55).

³ • You may need to check the digital audio output settings on your DVD player or digital satellite receiver. It should be set to output Dolby Digital, DTS and 88.2 kHz / 96 kHz PCM (2 channel) audio, and if there is an MPEG audio option, set this to convert the MPEG audio to PCM.
• Depending on your DVD player or source discs, you may only get digital 2 channel stereo and analog sound. In this case, the receiver must be set to a multichannel listening mode (see *Listening in surround sound* on page 50 if you need to do this) if you want multichannel surround sound.

Selecting the multichannel analog inputs

If you have connected a decoder or a DVD player as above, you must select the analog multichannel inputs for surround sound playback.¹

1 Make sure you have set the playback source to the proper output setting.

For example, you might need to set your DVD player to output multichannel analog audio.

2 Use INPUT SELECT to select MULTI CH IN.

You can also use the **INPUT SELECTOR** dial on the front panel.

- Depending on the DVD player you're using, the analog output level of the subwoofer channel may be too low. In this case, the output level of the subwoofer can be increased by 10 dB in the **Multi Ch In Setup** in **Other Setup**. For details, see *Multi Channel Input Setup* on page 89.

Playing an iPod

This receiver has a dedicated iPod terminal that will allow you to control playback of audio content from your iPod using the controls of this receiver.²

1 Switch on the receiver and your TV.

See *Connecting an iPod* on page 36.

- It is also possible to operate the iPod on the iPod itself, without using the TV screen. For details, see *Switching the iPod controls* on page 44.

2 Press iPod USB on the remote control to switch the receiver to the iPod/USB.

Loading appears in the GUI screen while the receiver verifies the connection and retrieves data from the iPod.

When the display shows **iPod** top menu you're ready to play music from the iPod.³

- Main Zone:**

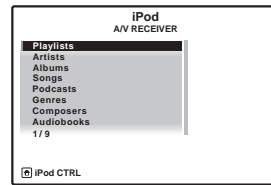

- Sub Zone:**



Playing back audio files stored on an iPod

To navigate songs on your iPod, you can take advantage of the GUI screen of your TV connected to this receiver.⁴ You can also control all operations for music in the front panel display of this receiver.

Finding what you want to play

When your iPod is connected to this receiver, you can browse songs stored on your iPod by playlist, artist name, album name, song name, genre or composer, similar to using your iPod directly.

1 Use ↑/↓ to select a category, then press ENTER to browse that category.

- To return to the previous level any time, press **RETURN**.

2 Use ↑/↓ to browse the selected category (e.g., albums).

- Use ←/→ to move to previous/next levels.

Note

- When playback from the multichannel inputs is selected, only the volume and channel levels can be set.
 - You can't listen to your speaker B system during playback from the multichannel inputs.
 - With **MULTI CH IN** inputs, it is possible to play pictures simultaneously. For details, see *Multi Channel Input Setup* on page 89.
- This system is compatible with the audio and video of the iPod nano, iPod fifth generation (audio only), iPod classic, iPod touch and iPhone. However, some of the functions may be restricted for some models. The system is not compatible with the iPod shuffle.
 - Compatibility may vary depending on the software version of your iPod and iPhone. Please be sure to use the latest available software version.
 - iPod and iPhone are licensed for reproduction of non-copyrighted materials or materials the user is legally permitted to reproduce.
 - Features such as the equalizer cannot be controlled using this receiver, and we recommend switching the equalizer off before connecting.
 - Pioneer cannot under any circumstances accept responsibility for any direct or indirect loss arising from any inconvenience or loss of recorded material resulting from the iPod failure.
 - When listening to a track on the iPod in the main zone, it is possible to control the sub zone, but not to listen to a different track in the sub zone from the one playing in the main zone.
- The controls of your iPod will be inoperable when connected to this receiver.
- Note that characters that cannot be displayed on this receiver are displayed as #.
 - This feature is not available for photos or video clips on your iPod. To display video clips, switch iPod operation to the iPod (see *Switching the iPod controls* on page 44).

3 Continue browsing until you arrive at what you want to play, then press ► to start playback.¹

- *Main Zone:*

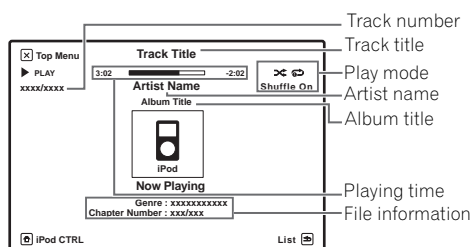

- *Sub Zone:*

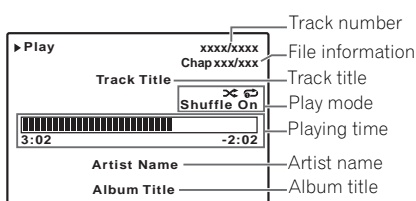

Navigation through categories on your iPod looks like this:

Playlists → Songs
 Artists → Albums → Songs
 Albums → Songs
 Songs
 Podcasts
 Genres → Artists → Albums → Songs
 Composers → Albums → Songs
 Audiobooks
 Shuffle Songs

Tip

- You can play all of the songs in a particular category by selecting the **All** item at the top of each category list. For example, you can play all the songs by a particular artist.

Basic playback controls

The following table shows the basic playback controls for your iPod. Press **iPod USB** to switch the remote control to the iPod/USB operation mode.

Button	What it does
►	Press to start playback. If you start playback when something other than a song is selected, all the songs that fall into that category will play.
	Pauses/unpauses playback.
◀◀/▶▶	Press and hold during playback to start scanning.
◀◀/▶▶	Press to skip to previous/next track.
↺	Press repeatedly to switch between Repeat One , Repeat All and Repeat Off .
↻	Press repeatedly to switch between Shuffle Songs , Shuffle Albums and Shuffle Off .
DISP	Press repeatedly to change the song playback information displayed in the front panel display.
ENTER	When browsing, press to move to next levels. During playback, press to set the play and pause modes.
RETURN	When browsing, press to move to previous levels.
◀/▶	When browsing, press to move to previous/next levels.
↑/↓	During Audiobook playback, press to switch the playback speed: Faster ↔ Normal ↔ Slower
TOP MENU	Press to return to the iPod top menu screen.

Switching the iPod controls²

You can switch over the iPod controls between the iPod and the receiver.

1 Press iPod CTRL to switch the iPod controls.³

This enables operation and display on your iPod, and this receiver's remote control and GUI screen become inactive.

2 Press iPod CTRL again to switch back to the receiver controls.

Note

- 1 If you're in the song category, you can also press **ENTER** to start playback.
- 2 You cannot use this function, when an iPod of fifth generation or iPod nano of first generation is connected.
- 3 When this function is set, iPod images cannot be played on this receiver. However, when video clips recorded on the iPod are played, the playback picture is displayed.

Playing a USB device

It is possible to playback files¹ using the USB interface on the front of this receiver.

1 Switch on the receiver and your TV.
See *Connecting a USB device* on page 36.²

2 Press iPod USB on the remote control to switch the receiver to the iPod/USB.

Loading appears in the GUI screen as this receiver starts recognizing the USB device connected.³ When the display shows **USB Top** menu you're ready to playback from the USB device.

- *Main Zone:*

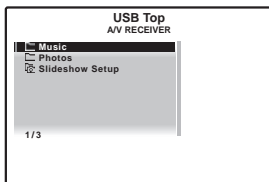

- *Sub Zone:*

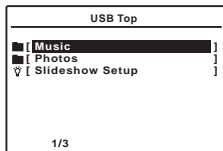

Important

If an **Over Current** message lights in the display, the power requirements of the USB device are too high for this receiver. Try following the points below:

- Switch the receiver off, then on again.
- Reconnect the USB device with the receiver switched off.
- Use a dedicated AC adapter (supplied with the device) for USB power.

If this doesn't remedy the problem, it is likely your USB device is incompatible.

Note

- Compatible USB devices include external magnetic hard drives, portable flash memory (particularly keydrives) and digital audio players (MP3 players) of format FAT16/32. It is not possible to connect this unit to a personal computer for USB playback.
 - Pioneer cannot guarantee compatibility (operation and/or bus power) with all USB mass storage devices and assumes no responsibility for any loss of data that may occur when connected to this receiver.
- Make sure the receiver is in standby when disconnecting the USB device.
- If the file selected cannot be played back, this receiver automatically skips to the next file playable.
 - When the file currently being played back has no title assigned to it, the file name is displayed in the GUI screen instead; when neither the album name nor the artist name is present, the row is displayed as a blank space.
 - Note that non-roman characters in the playlist are displayed as #.
 - If this error occurs, playback is interrupted and the next playable file is played automatically.
 - This error may occur if the title information is changed on a computer, etc.
- Playback stops when the last song in a USB memory device is played back to the end.
 - When a USB memory device with a large capacity is connected, it may take some time to read all the contents.
 - This receiver does not support a USB hub.
 - Copyrighted audio files cannot be played back on this receiver.
 - DRM-protected audio files cannot be played back on this receiver.

Playing back audio files stored on a USB memory device

The maximum number of levels that you can select in Step 2 (below) is 8. Also, you can display and play back up to 30 000 folders and files within a USB memory device.⁴

1 Use ↑/↓ to select 'Music' from the USB Top menu.

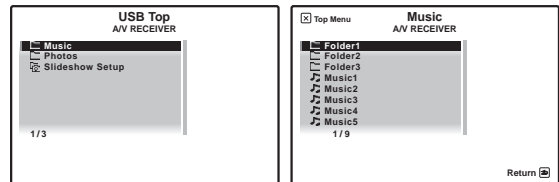

2 Use ↑/↓ to select a folder, then press ENTER to browse that folder.

- To return to the previous level any time, press **RETURN**.

3 Continue browsing until you arrive at what you want to play, then press ► to start playback.

- *Main Zone:*

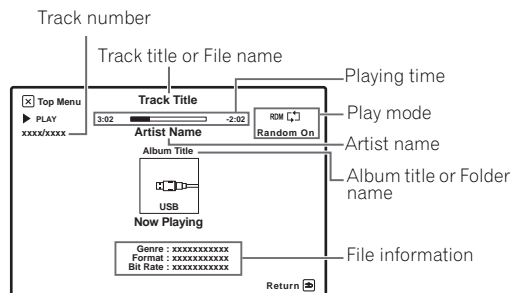

- *Sub Zone:*

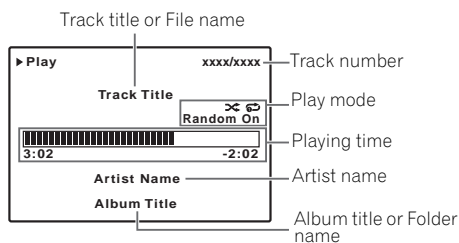

Basic playback controls

The following table shows the basic playback controls for your USB memory device. Press **iPod USB** to switch the remote control to the iPod/USB operation mode.

Button	What it does
▶	Press to start playback.
⏸	Pauses/unpauses playback.
◀▶	Press and hold during playback to start scanning.
⏮▶▶	Press to skip to previous/next track.
↺	Press repeatedly to switch between Repeat One , Repeat Folder , Repeat All and Repeat Off .
↻	Press repeatedly to switch between Random On and Random Off .
DISP	Press repeatedly to change the song playback information displayed in the front panel display.
ENTER	When browsing, press to move to next levels. During playback, press to set the play and pause modes.
RETURN	When browsing, press to move to previous levels.
◀▶	When browsing, press to move to previous/next levels.
TOP MENU	Press to return to the USB Top menu.

Playing back photo files stored on a USB memory device¹

- 1 Use **↑/↓** to select 'Photos' from the **USB Top** menu.

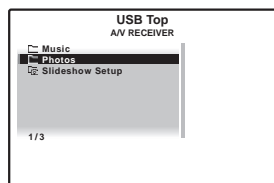

- 2 Use **↑/↓** to select a folder, then press **ENTER** to browse that folder.

- To return to the previous level any time, press **RETURN**.

- 3 Continue browsing until you arrive at what you want to play, then press **▶** to start playback.²

The selected content is displayed in full screen and starts a slideshow.

After a slideshow launches, pressing **ENTER** toggles between play and pause.

Basic playback controls

Button(s)	Function
ENTER, ▶	Starts displaying a photo and playing a slideshow.
RETURN, ◀	Stops the Player and returns to the previous menu.
⏮	Displays the previous photo content
⏭	Display the next photo content
⏸	Pauses/unpauses the slideshow

Slideshow Setup

Make the various settings for playing slideshows of photo files here.

- 1 Use **↑/↓** to select 'Slideshow Setup' from the **USB Top** menu.

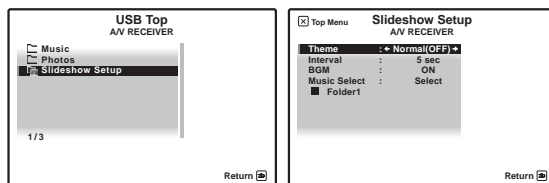

- 2 Select the setting you want.

- **Theme** – Add various effects to the slideshow.
- **Interval** – Set the interval for switching the photos. This may not be available depending on the **Theme** setting.
- **BGM** – Play music files stored on the USB device while displaying photos.
- **Music Select** – Select the folder containing the music files to be played when **BGM** is set to **ON**.

- 3 When you're finished, press **RETURN**.

You will return to the **USB Top** menu.

Note

¹ Photo files cannot be played in the sub zone.

² If the slideshow is left in the pause mode for five minutes, the list screen reappears.

About playable file formats

The USB function of this receiver supports the following file formats. Note that some file formats are not available for playback although they are listed as playable file formats.

Music files

Category	Extension	Stream		
MP3^a	.mp3	MPEG-1, 2, 2.5 Audio Layer-3	Sampling frequency	8 kHz to 48 kHz
			Quantization bitrate	16 bit
			Channel	2 ch
			Bitrate	8 kbps to 320 kbps
			VBR/CBR	Supported/Supported
WAV	.wav	LPCM	Sampling frequency	32 kHz, 44.1 kHz, 48 kHz
			Quantization bitrate	8 bit, 16 bit
			Channel	2 ch, Monaural
WMA	.wma	WMA8/g ^b	Sampling frequency	8 kHz to 48 kHz
			Quantization bitrate	16 bit
			Channel	2 ch
			Bitrate	8 kbps to 320 kbps
			VBR/CBR	Supported/Supported

a. "MPEG Layer-3 audio decoding technology licensed from Fraunhofer IIS and Thomson multimedia."

b. Files encoded using Windows Media Codec 9 may be playable but some parts of the specification are not supported; specifically, Pro, Lossless, Voice.

Photo files

Category	Extension		
JPEG	.jpg	Format	Meeting the following conditions:
	.jpeg		
	.jpe	Resolution	30 to 8192 pixels vertical, 40 to 8192 pixels horizontal
	.jif		
	.jfif		

Listening to the radio

The following steps show you how to tune in to FM and AM radio broadcasts using the automatic (search) and manual (step) tuning functions. If you already know the frequency of the station you want, see *Tuning directly to a station* below. Once you are tuned to a station you can memorize the frequency for recall later—see *Saving station presets* below for more on how to do this.

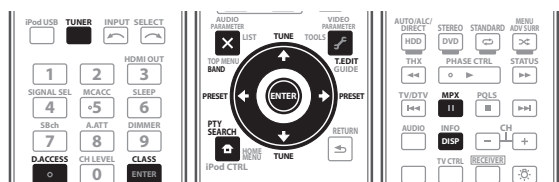

1 Press TUNER to select the tuner.

2 Use BAND to change the band (FM or AM), if necessary.

Each press switches the band between FM and AM.

3 Tune to a station.

There are three ways to do this:

Automatic tuning – To search for stations in the currently selected band, press and hold **TUNE** \uparrow/\downarrow for about a second. The receiver will start searching for the next station, stopping when it has found one. Repeat to search for other stations.

Manual tuning – To change the frequency one step at a time, press **TUNE** \uparrow/\downarrow .

High speed tuning – Press and hold **TUNE** \uparrow/\downarrow for high speed tuning. Release the button at the frequency you want.

Improving FM sound

If the **TUNED** or **STEREO** indicator doesn't light when tuning to an FM station because the signal is weak, press **MPX** to switch the receiver into mono reception mode. This should improve the sound quality and allow you to enjoy the broadcast.

Using Neural THX

This feature uses Neural Surround™, THX® technologies to achieve optimal surround sound from FM radio.

- While listening to FM radio, press **AUTO/ALC/DIRECT** for Neural THX listening.

See *About Neural – THX Surround* on page 103 for more on this.

The **Neural THX** mode can be selected also with **STANDARD**.

Tuning directly to a station

Sometimes, you'll already know the frequency of the station you want to listen to. In this case, you can simply enter the frequency directly using the number buttons on the remote control.

1 Press TUNER to select the tuner.

2 Use BAND to change the band (FM or AM), if necessary.

Each press switches the band between FM and AM.

3 Press D.ACCESS (Direct Access).

4 Use the number buttons to enter the frequency of the radio station.

For example, to tune to **106.00** (FM), press **1, 0, 6, 0, 0**.

If you make a mistake halfway through, press **D.ACCESS** twice to cancel the frequency and start over.

Saving station presets

If you often listen to a particular radio station, it's convenient to have the receiver store the frequency for easy recall whenever you want to listen to that station. This saves the effort of manually tuning in each time. This receiver can memorize up to 63 stations, stored in seven banks, or classes (A to G) of 9 stations each. When saving an FM frequency, the **MPX** setting (see above) is also stored.

1 Tune to a station you want to memorize.

See *Listening to the radio* above for more on this.

2 Press T.EDIT (TUNER EDIT).

The display shows **PRESET MEMORY**, then a blinking memory class.

3 Press CLASS to select one of the seven classes, then press PRESET \leftarrow/\rightarrow to select the station preset you want.

You can also use the number buttons to select a station preset.

4 Press ENTER.

After pressing **ENTER**, the preset class and number stop blinking and the receiver stores the station.

Naming station presets

For easier identification, you can name your station presets.

1 Choose the station preset you want to name.

See *Listening to station presets* below for how to do this.

2 Press T.EDIT (TUNER EDIT).

The display shows **PRESET NAME**, then a blinking cursor at the first character position.

3 Input the name you want.

Choose from the following characters for a name up to eight characters long.

ABCDEFGHIJKLMNOPQRSTUVWXYZ

abcdefghijklmnopqrstuvwxyz

0123456789

! " # \$ % & ' () * + , - . / : ; < = > ? @ [\] ^ _ { } ~ [space]

Use \uparrow/\downarrow to select a character, \leftarrow/\rightarrow to set the position, and **ENTER** to confirm your selection.

**Tip**

- To erase a station name, simply repeat steps 1 to 3 and input eight spaces instead of a name.
- Once you have named a station preset, you can press **DISP** when listening to a station to switch the display between name and frequency.

Listening to station presets

You will need to have some presets stored to do this. See *Saving station presets* on page 48 if you haven't done this already.

- 1 Press **TUNER** to select the tuner.
- 2 Press **CLASS** to select the class in which the station is stored.
Press repeatedly to cycle through classes A to G.
- 3 Press **PRESET** \leftarrow/\rightarrow to select the station preset you want.
 - You can also use the number buttons on the remote control to recall the station preset.

An introduction to RDS

Radio Data System (RDS) is a system used by most FM radio stations to provide listeners with various kinds of information—the name of the station and the kind of show they're broadcasting, for example.

One feature of RDS is that you can search by type of program. For example, you can search for a station that's broadcasting a show with the program type, **JAZZ**.

You can search the following program types:¹

- | | |
|--|--|
| NEWS – News | EASY M – Easy listening |
| AFFAIRS – Current Affairs | LIGHT M – 'Light' classical music |
| INFO – General Information | CLASSICS – 'Serious' classical music |
| SPORT – Sport | OTHER M – Music not fitting above categories |
| EDUCATE – Educational | WEATHER – Weather reports |
| DRAMA – Radio plays, etc. | FINANCE – Stock market reports, commerce, trading, etc. |
| CULTURE – National or regional culture, theater, etc. | CHILDREN – Programs for children |
| SCIENCE – Science and technology | SOCIAL – Social affairs |
| VARIED – Usually talk-based material, such as quiz shows or interviews. | RELIGION – Programs concerning religion |
| POP M – Pop music | PHONE IN – Public expressing their views by phone |
| ROCK M – Rock music | |

- TRAVEL** – Holiday-type travel rather than traffic announcements
- LEISURE** – Leisure interests and hobbies
- JAZZ** – Jazz
- COUNTRY** – Country music

- NATION M** – Popular music in a language other than English
- OLDIES** – Popular music from the '50s and '60s
- FOLK M** – Folk music
- DOCUMENT** – Documentary

Searching for RDS programs

One of the most useful features of RDS is the ability to search for a particular kind of radio program. You can search for any of the program types listed above.

- 1 Press **TUNER** to select the FM band.²
- 2 Press **PTY SEARCH**.
PTY SEARCH shows in the display.
- 3 Press **PRESET** \leftarrow/\rightarrow to select the program type you want to hear.
- 4 Press **ENTER** to search for the program type.
The system starts searching through all frequency for a match. When it finds one, the search stops and the station plays for five seconds.

5 If you want to keep listening to the station, press ENTER within the five seconds.

If you don't press **ENTER**, searching resumes.

If **NO PTY** is displayed it means the tuner couldn't find that program type at the time of the search.³

Displaying RDS information

Use the **DISP** button to display the different types of RDS information available.⁴

- Press **DISP** for RDS information.

Each press changes the display as follows:

- Radio Text (**RT**) – Messages sent by the radio station. For example, a talk radio station may provide a phone number as RT.
- Program Service Name (**PS**) – The name of the radio station.
- Program Type (**PTY**) – This indicates the kind of program currently being broadcast.
- Current tuner frequency.

Note

1 In addition, there are two other program types, **TEST** and **NONE**. You can't search for these.

2 RDS is only possible in the FM band.

3 RDS searches all frequency. If the program type could not be found among all frequency, **NO PTY** is displayed.

4 • If any noise is picked up while displaying the RT scroll, some characters may be displayed incorrectly.

• If you see **NO RT DATA** in the RT display, it means no RT data is sent from the broadcast station.

• If you see **NO PS DATA** in the PS display, it means no PS data can be received.

• If you see **NO PTY DATA** in the PTY display, it means no PTY data can be received.

Chapter 6:

Listening to your system

 Important

- The listening modes and many features described in this section may not be available depending on the current source, settings and status of the receiver.

Auto playback

There are many ways to listen back to sources using this receiver, but for the simplest, most direct listening option is the Auto Surround feature. The receiver automatically detects what kind of source you're playing and selects multichannel or stereo playback as necessary.¹

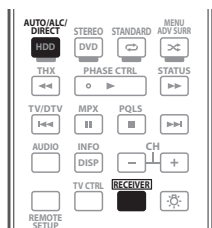

- While listening to a source, press **RECEIVER**, then press **AUTO/ALC/DIRECT (AUTO SURR/ALC/STREAM DIRECT)**² for auto playback of a source.

AUTO SURROUND shows briefly in the display before showing the decoding or playback format. Check the digital format indicators in the front panel display to see how the source is being processed.

- When listening to the FM radio, the Neural THX feature is selected automatically (see *Using Neural THX* on page 48 for more on this).

In the Auto level control (ALC) mode, this receiver equalizes playback sound levels.

 Tip

- When an **ALC** is selected, the effect level can be adjusted using the **EFFECT** parameter in *Setting the Audio options* on page 60.

Listening in surround sound

Using this receiver, you can listen to any source in surround sound. However, the options available will depend on your speaker setup and the type of source you're listening to.

If you connected surround back speakers, see also *Using surround back channel processing* on page 53.

Standard surround sound

The following modes provide basic surround sound for stereo and multichannel sources.³

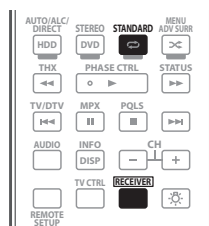





- While listening to a source, press **RECEIVER**, then press **STANDARD (STANDARD SURROUND)**.



If necessary, press repeatedly to select a listening mode.

- If the source is Dolby Digital, DTS, or Dolby Surround encoded, the proper decoding format will automatically be selected and shows in the display.⁴

With two channel sources, you can select from:

-  **Pro Logic IIx MOVIE** – Up to 7.1 channel sound, especially suited to movie sources
-  **Pro Logic IIx MUSIC** – Up to 7.1 channel sound, especially suited to music sources⁵
-  **Pro Logic IIx GAME** – Up to 7.1 channel sound, especially suited to video games
-  **PRO LOGIC** – 4.1 channel surround sound (sound from the surround speakers is mono)
- Neo:6 CINEMA** – 7.1 channel sound, especially suited to movie sources

 Note

- Stereo surround (matrix) formats are decoded accordingly using **Neo:6 CINEMA** or  **Pro Logic IIx MOVIE** (see *Listening in surround sound* above for more on these decoding formats).
- The Auto Surround feature is canceled if you connect headphones.
- For more options using this button, see *Using Stream Direct* on page 53.
- In modes that give 6.1 channel sound, the same signal is heard from both surround back speakers.
- If surround back channel processing (page 53) is switched **OFF**, or the surround back speakers are set to **NO** (this happens automatically if the *Surround back speaker setting* on page 85 is set to anything but **Normal**),  **Pro Logic IIx** becomes  **Pro Logic II** (5.1 channel sound).
- When listening to 2-channel sources in Dolby Pro Logic IIx Music mode, there are three further parameters you can adjust: **C.WIDTH**, **DIMENSION** and **PANORAMA**. See *Setting the Audio options* on page 60 to adjust them.

- **Neo:6 MUSIC** – 7.1 channel sound, especially suited to music sources¹
- **Neural THX** – Up to 7.1 channel sound, especially suited to music sources²

With multichannel sources, if you have connected surround back speaker(s) and have selected **SBch ON**, you can select (according to format):

- **Pro Logic IIx MOVIE** – See above (only available when you're using two surround back speakers)
- **Pro Logic IIx MUSIC** – See above
- **Dolby Digital EX** – Creates surround back channel sound for 5.1 channel sources and provides pure decoding for 6.1 channel sources (like Dolby Digital Surround EX)
- **DTS-ES** – Allows you to hear 6.1 channel playback with DTS-ES encoded sources
- **DTS Neo:6** – Allows you to hear 6.1 channel playback with DTS encoded sources

Using the Home THX modes

THX and Home THX are technical standards created by THX Ltd. for cinema and home theater sound. Home THX is designed to make home theater audio sound more like what you hear in a cinema.

Different THX options will be available depending on the source and the setting for surround back channel processing (see *Using surround back channel processing* on page 53 for more on this).

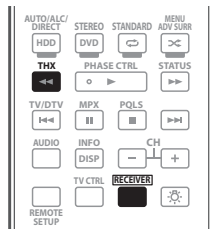

- Press **RECEIVER**, then press **THX (HOME THX)** to select a listening mode.³

With two channel sources, press **THX** repeatedly to select a matrix-decoding process for the **THX CINEMA** mode (see *Using surround back channel processing* on page 53 for an explanation of each process):

- **Pro Logic IIx MOVIE+THX CINEMA**
- **PRO LOGIC+THX CINEMA**
- **Neo:6 CINEMA+THX CINEMA**
- **Pro Logic IIx MUSIC+THX MUSIC**
- **Neo:6 MUSIC+THX MUSIC**
- **Pro Logic IIx GAME+THX GAMES**
- **THX SELECT2 GAMES**⁴

With multichannel sources, press **THX (HOME THX)** repeatedly to select from:⁵

- **THX Surround EX** – Allows you to hear 6.1 or 7.1 channel playback with 5.1 channel sources⁶
- **Pro Logic IIx MOVIE+THX CINEMA**⁴
- **THX SELECT2 CINEMA**⁴ – Allows you to hear 7.1 channel playback with 5.1 channel sources
- **Pro Logic IIx MUSIC+THX MUSIC**
- **THX SELECT2 MUSIC**⁴ – This mode is suited not only for sources recorded in Dolby Digital and DTS, but also to all multi-channel music sources (DVD-Audio, etc.).
- **THX SELECT2 GAMES**⁴ – This mode is suited to playing the sound of games.

Using the Advanced surround effects

The Advanced surround effects can be used for a variety of additional surround sound effects. Most Advanced Surround modes are designed to be used with film soundtracks, but some modes are also suited for music sources. Try different settings with various soundtracks to see which you like.

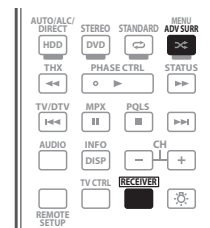

- Press **RECEIVER**, then press **ADV SURR (ADVANCED SURROUND)** repeatedly to select a listening mode.⁷

- **ACTION** – Designed for action movies with dynamic soundtracks

Note

- 1 When listening to 2-channel sources in Neo:6 Cinema or Neo:6 Music mode, you can also adjust the center image effect (see *Setting the Audio options* on page 60).
- 2 **Neural THX** can be selected for 2-channel signals for which the input signal is PCM (48 kHz or less), Dolby Digital, DTS or analog 2-channel sources.
- 3 • When the function is set to **TUNER** or **iPod/USB**, it is not possible to select **Pro Logic IIx GAME+THX GAMES** or **THX SELECT2 GAME**.
• When playing an SACD, **Pro Logic IIx MUSIC+THX MUSIC**, **Neo:6 MUSIC+THX MUSIC** and **THX SELECT2 MUSIC** can be selected.
- 4 Unavailable with only one surround back speaker connected.
- 5 **THX CINEMA**, **THX MUSIC** and **THX GAMES** can be selected when surround back processing is set to **SBch OFF**, when there is no surround back speaker, or when playing 6.1- and 7.1-channel sources.
- 6 When playing DTS-encoded sources, **Neo:6 CINEMA+THX CINEMA** can be selected, not **THX Surround EX**.
- 7 • Depending on the source and the sound mode you have selected, you may not get sound from the surround back speakers in your setup. For more on this, refer to *Using surround back channel processing* on page 53.
• If you press **ADV SURR** when the headphones are connected, the **PHONES SURR** mode will automatically be selected.

- **DRAMA** – Designed for movies with lots of dialog
- **SCI-FI** – Designed for science fiction with lots of special effects
- **MONO FILM** – Creates surround sound from mono soundtracks
- **ENT.SHOW** – Suitable for musical sources
- **EXPANDED** – Creates an extra wide stereo field¹
- **TV SURROUND** – Provides surround sound for both mono and stereo TV sources
- **ADVANCED GAME** – Suitable for video games
- **SPORTS** – Suitable for sports programs
- **CLASSICAL** – Gives a large concert hall-type sound
- **ROCK/POP** – Creates a live concert sound for rock and/or pop music
- **UNPLUGGED** – Suitable for acoustic music sources
- **EXT.STEREO** – Gives multichannel sound to a stereo source, using all of your speakers
- **PHONES SURR** – When listening through headphones, you can still get the effect of overall surround.

Tip

- When an Advanced Surround listening mode is selected, the effect level can be adjusted using the **EFFECT** parameter in *Setting the Audio options* on page 60.

Listening in stereo

When you select **STEREO**, you will hear the source through just the front left and right speakers (and possibly your subwoofer depending on your speaker settings). Dolby Digital, DTS and WMA9 Pro multichannel sources are downmixed to stereo.

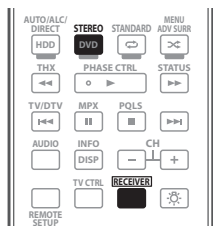

- While listening to a source, press **RECEIVER**, then press **STEREO** for stereo playback. Press repeatedly to switch between:

- **STEREO** – The audio is heard with your surround settings and you can still use the Midnight, Loudness, and Tone functions.
- **F.S.SURR FOCUS** – See *Using Front Stage Surround Advance* below for more on this.
- **F.S.SURR WIDE** – See *Using Front Stage Surround Advance* below for more on this.

Using Front Stage Surround Advance

The Front Stage Surround Advance function allows you to create natural surround sound effects using just the front speakers and the subwoofer.

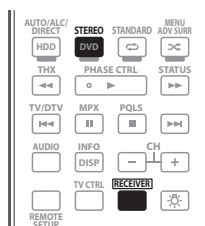

- While listening to a source, press **RECEIVER**, then press **STEREO** to select Front Stage Surround Advance modes.
- **STEREO** – See *Listening in stereo* above for more on this.
- **F.S.SURR FOCUS** – Use to provide a rich surround sound effect directed to the center of where the front left and right speakers sound projection area converges.
- **F.S.SURR WIDE** – Use to provide a surround sound effect to a wider area than **FOCUS** mode.²

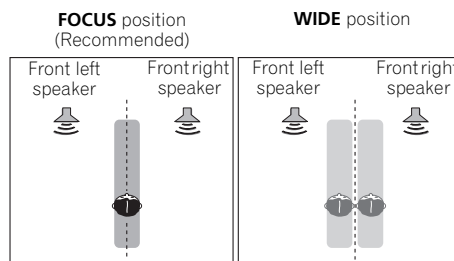

Note

- ¹ Use with Dolby Pro Logic for a stereo surround effect (stereo field is wider than Standard modes with Dolby Digital sources).
- ² When using **F.S.SURR WIDE**, a better effect can be obtained if the **Full Auto MCACC** procedure under **Advanced MCACC** is performed. For more on this, refer to *Automatically setting up for surround sound (Auto MCACC)* on page 39.

Using Stream Direct

Use the Stream Direct modes when you want to hear the truest possible reproduction of a source. All unnecessary signal processing is bypassed, and you're left with the pure analog or digital sound source.

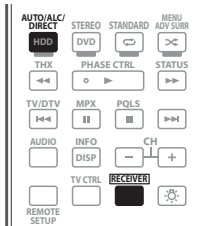

- While listening to a source, press **RECEIVER**, then press **AUTO/ALC/DIRECT (AUTO SURR/ALC/STREAM DIRECT)** to select the mode you want.

Check the digital format indicators in the front panel display to see how the source is being processed.

- **AUTO SURROUND** – See *Auto playback* on page 50.
- **ALC** – Listening in Auto level control mode (page 50).
- **DIRECT** – Sources are heard according to the settings made in the Surround Setup (speaker setting, channel level, speaker distance, acoustic calibration EQ, and X-curve), as well as with dual mono, the input attenuator, and any sound delay settings. You will hear sources according to the number of channels in the signal.
- **PURE DIRECT** – Analog sources are heard without any digital processing. No sound is output from the Speaker B in this mode.

Using surround back channel processing

- Default setting: **SBch ON**

You can have the receiver automatically use 6.1 or 7.1 decoding for 6.1 encoded sources (for example, Dolby Digital EX or DTS-ES), or you can choose to always use 6.1 or 7.1 decoding (for example, with 5.1 encoded material). With 5.1 encoded sources, a surround back channel will be generated, but the material may sound better in the 5.1 format for which it was originally encoded (in which case, you can simply switch surround back channel processing off).

- With a 7.1-channel surround system, audio signals that have undergone matrix decoding processing through surround back channel processing to which the Up Mix function is added are output from the surround back speakers.

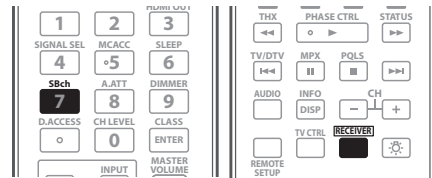

- Press **RECEIVER**, then press **SBch** repeatedly to cycle the surround back channel options.

Each press cycles through the options as follows:

- **SBch ON** – Matrix decoding processing for generating the surround back component from the surround component is turned on.
- **SBch AUTO** – Matrix decoding processing for generating the surround back component from the surround component is switched automatically. Matrix decoding processing is only performed when surround back channel signals are detected in the input signals.
- **SBch OFF** – Matrix decoding processing for generating the surround back component from the surround component is turned off.

Using the Virtual Surround Back mode

- Default setting: **OFF**

When you're not using surround back speakers, selecting this mode allows you to hear a virtual surround back channel through your surround speakers. You can choose to listen to sources with no surround back channel information, or if the material sounds better in the format (for example, 5.1) for which it was originally encoded, you can have the receiver only apply this effect to 6.1 encoded sources like Dolby Digital EX or DTS-ES.¹

- Press **SBch** repeatedly to cycle the virtual surround back channel options.

Each press cycles through the options as follows:

- **VirtualSB ON** – Virtual Surround Back is always used (for example, on 5.1 encoded material)
- **VirtualSB AUTO** – Virtual Surround Back is automatically applied to 6.1 encoded sources (for example, Dolby Digital EX or DTS-ES)
- **VirtualSB OFF** – Virtual Surround Back mode is switched off

Note

- You can't use the Virtual Surround Back mode when the headphones are connected to this receiver or when any of the stereo, Front Stage Surround Advance or Stream Direct mode is selected.
- You can only use the Virtual Surround Back mode if the surround speakers are on and the **SB** setting is set to **NO** or if **Front Bi-Amp, Speaker B** or **ZONE 2** is selected at **Surr Back System**.
- The Virtual Surround Back mode cannot be applied to sources that do not have surround channel information.

Setting the Up Mix function

In a 7.1-channel surround system with surround speakers placed directly at the sides of the listening position, the surround sound of 5.1-channel sources is heard from the side. The Up Mix function mixes the sound of the surround speakers with the surround back speakers so that the surround sound is heard from diagonally to the rear as it should be.¹

- Using the Up Mix function is effective when the speakers in the 7.1-channel surround system are set up as recommended in the example on page 17.
- Depending on the positions of the speakers and the sound source, in some cases it may not be possible to achieve good results. In this case, set the setting to **OFF**.

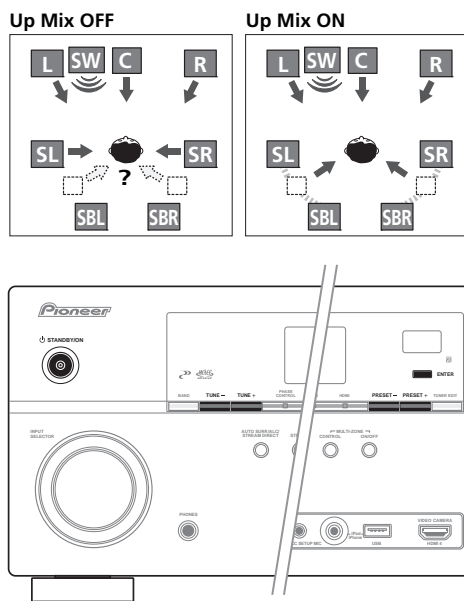

1 Switch the receiver into standby.

2 While holding down ENTER on the front panel, press STANDBY/ON.

The display shows **RESET ◀ NO ▶**.

Use **TUNE +/-** (or on the remote control) to select **UP MIX ◀ON ▶**, and then use **PRESET +/-** (or on the remote control) to select **ON** or **OFF**.

3 Press ENTER to confirm.

- When set to **ON**, the **UP MIX** indicator on the front panel lights.

Selecting MCACC presets

- Default setting: **MEMORY 1**

If you have calibrated your system for different listening positions², you can switch between settings to suit the kind of source you're listening to and where you're sitting (for example, watching movies from a sofa, or playing a video game close to the TV).

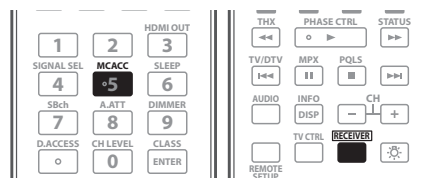

- **While listening to a source, press **RECEIVER**, then press **MCACC**.**

Press repeatedly to select one of the six MCACC presets³. See *Data Management* on page 82 to check and manage your current settings.

Note

- Set to **ON** regardless of this setting when playing DTS-HD signals.
- May automatically be set to **OFF** even when set to **ON**, depending on the input signal and listening mode.
- Different presets might also have separate calibration settings for the same listening position, depending on how you're using your system. These presets can be set in *Automatically setting up for surround sound (Auto MCACC)* on page 39 or *Automatic MCACC (Expert)* on page 72, either of which you should have already completed.
- These settings have no effect when headphones are connected.
- You can also press to select the MCACC preset.

Choosing the input signal

On this receiver, it is possible to switch the input signals for the different inputs as described below.¹

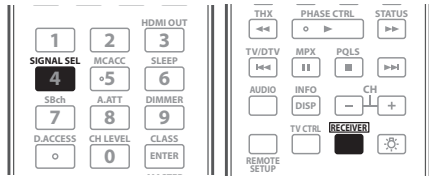

- Press **RECEIVER**, then press **SIGNAL SEL** to select the input signal corresponding to the source component.

Each press cycles through the options as follows:

- **AUTO** – The receiver selects the first available signal in the following order: **HDMI; DIGITAL; ANALOG**.
- **ANALOG** – Selects an analog signal.
- **DIGITAL** – Selects an optical or coaxial digital signal.
- **HDMI** – Selects an HDMI signal.²
- **PCM** – For PCM input signals.³ The receiver selects the first available signal in the following order: **HDMI; DIGITAL**.

When set to **DIGITAL** or **AUTO**, the indicators light according to the signal being decoded, as follows:

- **DIGITAL** lights with Dolby Digital decoding.
- **DIGITAL PLUS** lights with Dolby Digital Plus decoding.
- **TrueHD** lights with Dolby TrueHD decoding.
- **DTS** lights with DTS decoding.
- **DTS HD** lights with DTS-HD decoding.
- **MSTR** lights with DTS-HD Master Audio decoding.
- **96/24** lights with DTS 96/24 decoding.
- **WMA9 Pro** lights to indicate that a WMA9 Pro signal is being decoded.

- **HDMI** is not assigned by default. To select an HDMI signal, conduct the input setup procedure (see *The Input Setup menu* on page 40).

Better sound using Phase Control

This receiver's Phase Control feature uses phase correction measures to make sure your sound source arrives at the listening position in phase, preventing unwanted distortion and/or coloring of the sound.

During multichannel playback, LFE (Low-Frequency Effects) signals as well as low-frequency signals in each channel are assigned to the subwoofer or other the subwoofer and the most appropriate speaker. At least in theory, however, this type of processing involves a group delay that varies with frequency, resulting in phase distortion where the low-frequency sound is delayed or muffled by the conflict with other channels. With the Phase Control mode switched on, this receiver can reproduce powerful bass sound without deteriorating the quality of the original sound (see illustration below).

Phase Control OFF

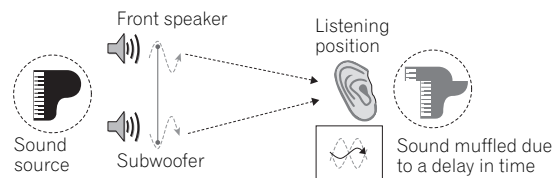

- Rhythms blurred and difficult to hear
- Bass sound with loss of depth
- Sound of musical instruments with no reality

Phase Control ON

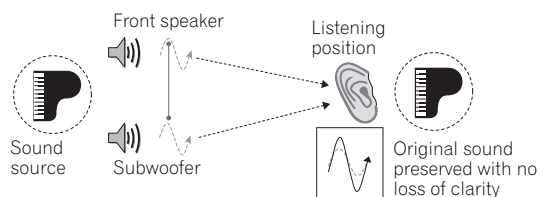

- Rhythms with crystal-like clarity
- Bass sound with no loss of depth
- Sound of musical instruments with superb reality

Note

- 1 • This receiver can only play back Dolby Digital, PCM (32 kHz to 192 kHz), DTS (including DTS 96/24) and WMA9 Pro digital signal formats. The compatible signals via the HDMI terminals are: Dolby Digital, DTS, WMA9 Pro, PCM (32 kHz to 192 kHz), Dolby TrueHD, Dolby Digital Plus, DTS-EXPRESS, DTS-HD Master Audio, SACD and DVD Audio (including 192 kHz). With other digital signal formats, set to **ANALOG** (the **MULTI CH IN** and **TUNER**).
 - You may get digital noise when a LD or CD player compatible with DTS is playing an analog signal. To prevent noise, make the proper digital connections (page 28) and set the signal input to **DIGITAL**.
 - Some DVD players don't output DTS signals. For more details, refer to the instruction manual supplied with your DVD player.
- 2 When the **HDMI** audio output parameter is set to **THROUGH**, the sound will be heard through your TV, not from this receiver.
- 3 • This is useful if you find there is a slight delay before **AUTO** recognizes the PCM signal on a CD, for instance.
 - When **PCM** is selected, noise may be output during playback of non-PCM sources. Please select another input signal if this is a problem.

Phase Control technology provides coherent sound reproduction through the use of phase matching¹ for an optimal sound image. The default setting is on and we recommend leaving Phase Control switched on for all sound sources.

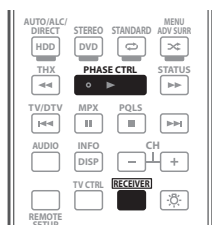

- Press **RECEIVER**, then press **PHASE CTRL (PHASE CONTROL)** to switch on phase correction. The **PHASE CONTROL** indicator on the front panel lights.

Note

- Phase matching is a very important factor in achieving proper sound reproduction. If two waveforms are 'in phase', they crest and trough together, resulting in increased amplitude, clarity and presence of the sound signal. If a crest of a wave meets a trough, then the sound will be 'out of phase' and an unreliable sound image will be produced.
 - The **PHASE CONTROL** feature is available even when the headphones are plugged in.
 - If your subwoofer has a phase control switch, set it to the plus (+) sign (or 0°). However, the effect you can actually feel when **PHASE CONTROL** is set to **ON** on this receiver depends on the type of your subwoofer. Set your subwoofer to maximize the effect. It is also recommended you try changing the orientation or the place of your subwoofer.
 - Set the built-in lowpass filter switch of your subwoofer to off. If this cannot be done on your subwoofer, set the cutoff frequency to a higher value.
 - If the speaker distance is not properly set, you may not have a maximized **PHASE CONTROL** effect.
 - The **PHASE CONTROL** mode cannot be set to **ON** in the following cases:
 - When the **PURE DIRECT** mode is switched on.
 - When the **MULTI CH IN** input is selected.
 - When the **HDMI** audio output parameter is set to **THROUGH** in *Setting the Audio options* on page 60.

Chapter 7: KURO LINK

Synchronized operation with a KURO LINK-compatible Pioneer flat screen TV or Blu-ray disc player or with a component of another make that supports the KURO LINK function is possible when the component is connected to the receiver using an HDMI cable.

For details about concrete operations, settings, etc., refer to also the operating instructions for each component.

- You cannot use this function with components that do not support KURO LINK.
- We do not guarantee this receiver will work with Pioneer KURO LINK-compatible components or components of other makes that support the KURO LINK function. We do not guarantee that all synchronized operations will work with components of other makes that support the KURO LINK function.
- Use a High Speed HDMI™ cable when you want to use the KURO LINK function. The KURO LINK function may not work properly if a different type of HDMI cable is used.
- To use the KURO LINK function, connect this receiver and flat screen TV using the **HDMI OUT 1** terminal. Connecting the KURO LINK compatible component using the **HDMI OUT 2** terminal may result in malfunction. If this happens, turn off the KURO LINK compatible component's KURO LINK setting.
- While the receiver is equipped with four HDMI inputs, the KURO LINK function can only be used with up to three DVD or Blu-ray disc players or up to three DVD or Blu-ray disc recorders.

Cautions on the KURO LINK function

- Connect the TV directly to this receiver. Interrupting a direct connection with other amps or an AV converter (such as an HDMI switch) can cause operational errors.
- Only connect components (Blu-ray disc player, etc.) you intend to use as a source to the HDMI input of this receiver. Interrupting a direct connection with other amps or an AV converter (such as an HDMI switch) can cause operational errors.
- When **KURO LINK** is set to **ON**, HDMI Input is automatically set to **OFF**.
- If a listening mode other than **AUTO SURROUND**, **ALC**, **DIRECT**, **PURE DIRECT** or **STEREO** is selected while the PQLS effect is enabled, the PQLS effect is disabled.
- When this receiver is connected by HDMI cable to a Pioneer player that is compatible with the PQLS function via HDMI connection and HDMI reauthentication is performed (the **HDMI** indicator blinks), the PQLS effect is enabled and the listening mode is set to **AUTO SURROUND** if a listening mode other than **AUTO SURROUND**, **ALC**, **DIRECT**, **PURE DIRECT** or **STEREO** is selected.
- When the receiver's **KURO LINK** is turned **ON**, even if the receiver's power is in the standby mode, it is possible to output the audio and video signals from a player via HDMI to the TV without producing sound from the receiver, but only when a KURO LINK-compatible component (Blu-ray disc player, etc.) and compatible TV are connected. In this case, the receiver's power turns on and the power and **HDMI** indicators light.

Making the KURO LINK connections

You can use synchronized operation for a connected flat screen TV and up to four other components.

Be sure to connect the flat screen TV's audio cable to the audio input of this unit.

For details, see *Connecting your TV and playback components* on page 23.

Important

- When connecting this system or changing connections, be sure to switch the power off and disconnect the power cord from the wall socket. After completing all connections, connect the power cords to the wall socket.
- After this receiver is connected to an AC outlet, a 2 second to 10 second HDMI initialization process begins. You cannot carry out any operations during initialization. The HDMI indicator on the display unit blinks during initialization, and you can turn this receiver on once it has stopped blinking.
- To get the most out of this function, we recommend that you connect your HDMI component not to a flat screen TV but rather directly to the HDMI terminal on this receiver.

About connections with a product of a different brand that supports the KURO LINK function

The synchronized operations below can be used when the receiver's KURO LINK function is connected to a TV of a brand other than Pioneer that supports the KURO LINK function. (Depending on the TV, however, some of the KURO LINK functions may not work.)

- You can set whether to output the sound over the speakers connected to the receiver or over the TV's speakers using the TV's menu screen.
- You can adjust the receiver's volume or mute the sound using the TV's remote control.
- When the TV's power is set to standby, the receiver's power is also set to standby. (Only when the input for a component connected to the receiver by HDMI connection is selected or when watching the TV.)
- The sound of TV programs or an external input connected to the TV can also be output from the speakers connected to the receiver. (This requires connection of an optical digital cable, etc., in addition to the HDMI cable.)

The synchronized operations below can be used when the receiver's KURO LINK function is connected to a player or recorder of a brand other than Pioneer that supports the KURO LINK function.

- When playback starts on the player or recorder, the receiver's input switches to the HDMI input to which that component is connected.

See the Pioneer website for the latest information on the models of non-Pioneer brands and products that support the KURO LINK function.

KURO LINK Setup

You must adjust the settings of this receiver as well as KURO LINK-compatible connected components in order to make use of the KURO LINK function. For more information see the operating instructions for each component.

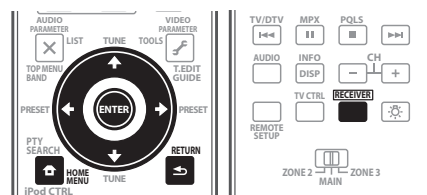

- 1 Press **RECEIVER**, then press Home Menu.
- 2 Select 'System Setup', then press ENTER.
- 3 Select 'Other Setup', then press ENTER.

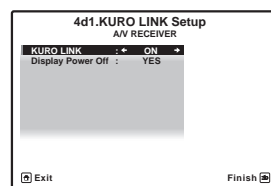
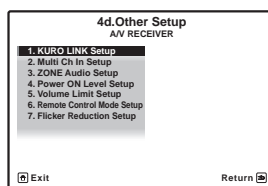

- 4 Select the 'KURO LINK' setting you want.

Choose whether to set this unit's KURO LINK function **ON** or **OFF**. You will need to set it to **ON** to use the KURO LINK function.

When using a component that does not support the KURO LINK function, set this to **OFF**.

- **ON** – Enables the KURO LINK function. When this unit's power is turned off and you have a supported source begin playback while using the KURO LINK function, the audio and video output from the HDMI connection are output from the flat screen TV.
- **OFF** – The KURO LINK is disabled. Synchronized operations cannot be used. When this unit's power is turned off, audio and video of sources connected via HDMI are not output.

- 5 Select the 'Display Power Off' setting you want.

If the TV's power is turned off while using the KURO LINK function, the receiver's power is also turned off (all power off function). This function can be disabled.

- **YES** – The all power off function is enabled. The receiver's power turns off together with the TV's power. This function only works when the input for a component connected to the receiver by HDMI connection is selected or when watching the TV.
- **NO** – The all power off function is disabled. The receiver's power is not affected when the TV's power is turned off.

- 6 When you're finished, press HOME MENU.

You will finish to **HOME MENU**.

Setting the PQLS function

PQLS (Precision Quartz Lock System) is a digital audio signal transfer control technology using the KURO LINK function. It offers higher-quality audio playback by controlling audio signals from the receiver to a PQLS compatible player, etc. This enables removing jitter that has a negative effect on the quality of the sound and is generated upon transmission.

- On players compatible with PQLS Multi Surround, PQLS works for all sources. Set the player's audio output to Linear PCM.
- On players compatible with PQLS 2 ch Audio, PQLS only works when playing CDs.

To use the PQLS function, set PQLS in the player's Setup Navigator to **AUTO**.

Please refer to the operating instructions supplied with your player for more information.

This function is activated when **KURO LINK** is set to **ON**.

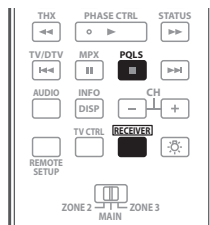

- Press **RECEIVER**, then press **PQLS** to select **PQLS** setting.

The setting is displayed on the front panel display.

- **PQLS AUTO** – PQLS is enabled. A precision quartz controller in this receiver eliminates distortion caused by timing errors (jitter), giving you the best possible digital-to-analog conversion when you use the HDMI interface. This is valid as an HDMI function for PQLS-compatible players.
- **PQLS OFF** – PQLS is disabled.

Before using synchronization

Once you have finished all connections and settings, you must:

- 1 Put all components into standby mode.
- 2 Turn the power on for all components, with the power for the flat screen TV being turned on last.
- 3 Choose the HDMI input to which the TV is connected to this receiver, and see if video output from connected components displays properly on the screen or not.
- 4 Check whether the components connected to all HDMI inputs are properly displayed.

Synchronized amp mode

The synchronized amp mode can be set from the KURO LINK-compatible TV's remote control. See the explanation below for operations in the synchronized amp mode.

These functions are set from the TV's menu screen. For more information, refer to the operating instructions of the KURO LINK-compatible TV.

Synchronized amp mode operations

When using the synchronized amp mode, the KURO LINK-compatible component connected to the receiver operates in sync as described below.

- The receiver's volume can be set and the sound can be muted using the TV's remote control.
- When the TV's power is set to standby, the receiver's power is also set to standby. (Only when the input for a component connected to the receiver by HDMI connection is selected or when watching the TV.)
- The receiver's input switches automatically when the KURO LINK-compatible component is played.
- The receiver's input switches automatically when the TV's channel is switched.
- The synchronized amp mode remains in effect even if the receiver's input is switched to a component other than one connected by HDMI.

The operations below can also be used on Pioneer KURO LINK-compatible flat screen TVs.

- When the receiver's volume is adjusted or the sound is muted, the volume status is displayed on the flat screen TV's screen.
- When the OSD language is switched on the flat screen TV, the receiver's language setting also switches accordingly.

Canceling synchronized amp mode

- When the synchronized amp mode is canceled, the receiver's power turns off if you were viewing an HDMI input or a TV program on the TV.
- When in the synchronized amp mode, the synchronized amp mode is canceled when the receiver's power is turned off. To turn the synchronized amp mode back on, select the synchronized amp mode using the TV's remote control.
- When in the synchronized amp mode, the synchronized amp mode is canceled if an operation that produces sound from the TV is performed from the TV's menu screen, if the receiver's HDMI output setting is changed, etc.

Chapter 8: Using other functions

Setting the Audio options

There are a number of additional sound settings you can make using the **AUDIO PARAMETER** menu. The defaults, if not stated, are listed in bold.



Important

- Note that if a setting doesn't appear in the **AUDIO PARAMETER** menu, it is unavailable due to the current source, settings and status of the receiver.

1 Press **RECEIVER**, then press **AUDIO PARAMETER**.

2 Use **↑/↓** to select the setting you want to adjust. Depending on the current status/mode of the receiver, certain options may not be able to be selected. Check the table below for notes on this.

3 Use **←/→** to set it as necessary.

See the table below for the options available for each setting.

4 Press **RETURN** to confirm and exit the menu.

Setting	What it does	Option(s)
MCACC (MCACC preset)	Selects your favorite MCACC preset memory when multiple preset memories are saved. When an MCACC preset memory has been renamed, the given name is displayed.	<i>M1. MEMORY 1</i> to <i>M6. MEMORY 6</i> Default: M1. MEMORY 1
EQ (Acoustic Calibration EQ)	Switches on/off the effects of EQ Pro.	ON <i>OFF^a</i>
S-WAVE (Standing Wave)	Switches on/off the effects of Standing Wave Control.	ON <i>OFF</i>
DELAY (Sound Delay)	Some monitors have a slight delay when showing video, so the soundtrack will be slightly out of sync with the picture. By adding a bit of delay, you can adjust the sound to match the presentation of the video.	0.0 to 10.0 (frames) <i>1 second = 25 frames (PAL)</i> Default: 0.0
MIDNIGHT	Allows you to hear effective surround sound of movies at low volumes.	MIDNIGHT/LOUDNESS OFF <i>MIDNIGHT ON</i>
LOUDNESS	Used to get good bass and treble from music sources at low volumes.	<i>LOUDNESS ON</i>

Setting	What it does	Option(s)
TONE^b (Tone Control)	Applies the treble and bass tone controls to a source, or bypasses them completely.	BYPASS <i>ON</i>
BASS^c	Adjusts the amount of bass.	-6 to +6 (dB) Default: 0 (dB)
TREBLE^c	Adjusts the amount of treble.	-6 to +6 (dB) Default: 0 (dB)
S.RTRV (Sound Retriever)	With the Sound Retriever function, DSP processing is used to compensate for the loss of audio data upon compression, improving the sound's sense of density and modulation.	OFF^d <i>ON</i>
DNR (Digital Noise Reduction)	May improve the quality of sound in a noisy source (for example, video tape with lots of background noise) when switched on.	OFF <i>ON</i>
DIALOG E. (Dialog Enhancement)	Localizes dialog in the center channel to make it stand out from other background sounds in a TV or movie soundtrack.	OFF <i>ON</i>
DUAL (Dual Mono)	Specifies how dual mono encoded Dolby Digital soundtracks should be played. Dual mono is not widely used, but is sometimes necessary when two languages need to be sent to separate channels.	CH1 – Channel 1 is heard only CH2 – Channel 2 is heard only <i>CH1 CH2</i> – Both channels heard from front speakers
DRC (Dynamic Range Control)	Adjusts the level of dynamic range for movie soundtracks optimized for Dolby Digital, DTS, Dolby Digital Plus, Dolby TrueHD, DTS-HD and DTS-HD Master Audio (you may need to use this feature when listening to surround sound at low volumes).	AUTO^e <i>MAX</i> <i>MID</i> <i>OFF</i>
LFE (LFE Attenuate)	Some Dolby Digital and DTS audio sources include ultra-low bass tones. Set the LFE attenuator as necessary to prevent the ultra-low bass tones from distorting the sound from the speakers. The LFE is not limited when set to 0 dB, which is the recommended value. When set to -5 dB, -10 dB, -15 dB or -20 dB, the LFE is limited by the respective degree. When OFF is selected, no sound is output from the LFE channel.	0dB/ -5dB/ -10dB/ -15dB/ -20dB <i>OFF</i>

Setting	What it does	Option(s)
SACD GAIN^f	Brings out detail in SACDs by maximizing the dynamic range (during digital processing).	0dB +6 dB
HDMI^g (HDMI Audio)	Specifies the routing of the HDMI audio signal out of this receiver (<i>amp</i>) or <i>through</i> to a TV or flat screen TV. When THROUGH is selected, no sound is output from this receiver.	AMPLIFIER <i>THROUGH</i>
A. DELAY (Auto delay)	This feature automatically corrects the audio-to-video delay between components connected with an HDMI cable. The audio delay time is set depending on the operational status of the display connected with an HDMI cable. The video delay time is automatically adjusted according to the audio delay time. ^h	OFF <i>ON</i>
C. WIDTHⁱ (Center Width) (Applicable only when using a center speaker)	Provides a better blend of the front speakers by spreading the center channel between the front right and left speakers, making it sound wider (higher settings) or narrower (lower settings).	0 to 7 Default: 3
DIMENSIONⁱ	Adjusts the depth of the surround sound balance from front to back, making the sound more distant (minus settings), or more forward (positive settings).	-3 to +3 Default: 0
PANORAMAⁱ	Extends the front stereo image to include the surround speakers for a 'wraparound' effect.	OFF <i>ON</i>
C. IMAGE^j (Center Image) (Applicable only when using a center speaker)	Adjusts the center image to create a wider stereo effect with vocals. Adjust the effect from 0 (all center channel sent to front right and left speakers) to 10 (center channel sent to the center speaker only).	0 to 10 Defaults: Neo:6 MUSIC: 3 Neo:6 CINEMA: 10
EFFECT	Sets the effect level for the currently selected Advanced Surround or ALC mode (each mode can be set separately).	10 to 90

a. When **EQ OFF** is selected, the MCACC indicator does not light.

b. This setting is only displayed when the listening mode is Stereo, Auto surround (STEREO) or ALC (STEREO).

c. The adjustment can be made only when **TONE** is set to **ON**.

d. With the **iPod/USB** input function, by default **S.RTRV** is set to **ON**.

e. The initially set **AUTO** is only available for Dolby TrueHD signals. Select **MAX** or **MID** for signals other than Dolby TrueHD.

f. You shouldn't have any problems using this with most SACD discs, but if the sound distorts, it is best to switch the gain setting back to **0 dB**.

g. • HDMI Audio setting cannot be switched while performing synchronized amp mode operations.

• The synchronized amp mode must be turned on in order to play the receiver's HDMI audio and video input signals from the TV with the receiver's power in the standby mode. See *Synchronized amp mode* on page 59.

h. This feature is only available when the connected display supports the automatic audio/video synchronizing capability ('lipsync') for HDMI. If you find the automatically set delay time unsuitable, set **A. DELAY** to **OFF** and adjust the delay time manually. For more details about the lipsync feature of your display, contact the manufacturer directly.

i. Only when listening to 2-channel sources in Dolby Pro Logic IIx Music/Dolby Pro Logic II Music mode.

j. Only when listening to 2-channel sources in Neo:6 MUSIC/CINEMA mode.

Setting the Video options

There are a number of additional picture settings you can make using the **VIDEO PARAMETER** menu. The defaults, if not stated, are listed in bold.

Important

- Note that if an option cannot be selected on the **VIDEO PARAMETER** menu, it is unavailable due to the current source, setting and status of the receiver.
- The **VIDEO PARAMETER** menu cannot be used when the input function is set to **iPod/USB**, **CD**, **CD-R**, **TUNER**, **BD** or **HDMI 1** to **4**.

1 Press **RECEIVER, then press VIDEO PARAMETER.**

2 Use **↑/↓ to select the setting you want to adjust.**

Depending on the current status/mode of the receiver, certain options may not be able to be selected. Check the table below for notes on this.

3 Use **←/→ to set it as necessary.**

See the table below for the options available for each setting.¹

4 Press RETURN to confirm and exit the menu.

Setting	What it does	Option(s)
V. CONV (Digital Video Conversion)	Converts video signals for output from the MONITOR OUT jacks (including HDMI OUT connector) for all video types (see page 22).	ON <i>OFF</i>
RES^a (Resolution)	Specifies the output resolution of the video signal (when analog video input signals are output at the HDMI OUT connector, select this according to the resolution of your monitor and the images you wish to watch).	AUTO <i>PURE</i> 480p/576p 720p 1080i 1080p

Note

- ¹ • All of the setting items can be set for each input function.
• Setting items other than **V. CONV** can only be selected when **V. CONV** is set to **ON**.

Setting	What it does	Option(s)
ASP ^b (Aspect)	Specifies the aspect ratio when analog video input signals are output at the HDMI output. Make your desired settings while checking each setting on your display (if the image doesn't match your monitor type, cropping or black bands appear).	THROUGH <i>NORMAL</i>
PCINEMA ^{c,d,e} (PureCinema)	This setting optimizes the picture for film material when the video output is set to progressive. Usually set to AUTO ; but try switching to OFF if the picture appears unnatural. Additionally, certain PAL movie video (576i, 25 frames/second STB video output or DVD disc playback, etc.) that contain film progressive material cannot be recognized as such by this receiver. In such instances, if you choose PAL , PureCinema mode is activated.	AUTO <i>PAL</i> <i>OFF</i>
P.MOTION ^{c,e} (Progressive Motion)	Adjusts the motion and still picture quality when video output is set to progressive.	-4 to +4 Default: 0
YNR ^c	Adjusts the amount of noise reduction (NR) applied to the Y (brightness) component.	0 to +8 Default: 0
DETAIL ^c	Adjusts how sharp edges appear.	-4 to +4 Default: 0
SHARP ^{c,f} (Sharpness)	Adjusts the sharpness of the high-frequency (detailed) elements in the picture.	-4 to +4 Default: 0
BRIGHT ^c (Brightness)	Adjusts the overall brightness.	-6 to +6 Default: 0
CONTRAST ^c	Adjusts the contrast between light and dark.	-6 to +6 Default: 0
HUE ^{c,g}	Adjusts the red/green balance.	-6 to +6 Default: 0
CHROMA ^c (Chroma Level)	Adjusts saturation from dull to bright.	-6 to +6 Default: 0

- a. • When set to a resolution with which the TV (monitor) is not compatible, no picture is output. Also, in some cases no picture will be output due to copyright protection signals. In this case, change the setting.
- When **AUTO** is selected, the resolution is selected automatically according to the capacity of the TV (monitor) connected by HDMI. When **PURE** is selected, the signals are output with the same resolution as when input (At this time, video signals are only output from the same type of terminals to which they were input).
 - When a display is connected by HDMI, if this is set to something other than **PURE** and 480i/576i analog signals are input, 480p/576p signals are output from the component output terminals.
- b. • If the image doesn't match your monitor type, adjust the aspect ratio on the source component or on the monitor.
- **NORMAL** setting is only displayed when 480i/p or 576i/p video signals are being input.

- c. This setting is only displayed when 480i or 576i video signals are being input.
- d. If the picture does not display properly when **PAL** is selected, select **AUTO** or **OFF**.
- e. This setting is only valid for component outputs.
- f. This setting is not valid for HDMI outputs.
- g. This setting is not displayed for component inputs.

Switching the speaker system

If you selected **Speaker B** in *Surround back speaker setting* on page 85, three speaker system settings are possible using **SPEAKERS**. If you selected **Normal, Front Bi-Amp** or **ZONE 2**, the button will simply switch your main speaker system on or off. The options below are for the **Speaker B** setting only.¹

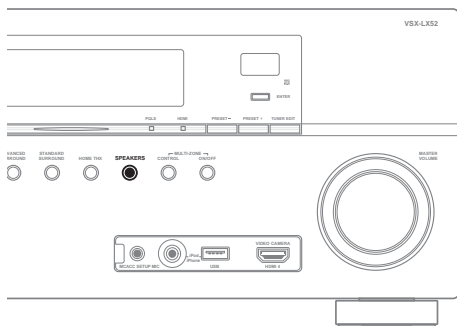

- Use **SPEAKERS** on the front panel to select a speaker system setting.

As mentioned above, if you have selected **Normal**, the button will simply switch your main speaker system (A) on or off.

Press repeatedly to choose a speaker system option:

- **SP▶A** – Sound is output from speaker system A and the same signal is output from the pre-out terminals.
- **SP▶B** – Sound is output from the two speakers connected to speaker system B. Multichannel sources will not be heard. The same signal is output from the surround back channel pre-out terminals.
- **SP▶AB** – Sound is output from speaker system A (up to 5 channels, depending on the source), the two speakers in speaker system B, and the subwoofer. The sound from speaker system B will be the same as the sound from speaker system A (multichannel sources will be downmixed to 2 channels).
- **SP▶ (off)** – No sound is output from the speakers. The same sound is output from the pre-out terminals (including from your subwoofer, if connected) as when selecting speaker system A (above).

Using the MULTI-ZONE controls

The following steps use the front panel controls to adjust the sub zone volume and select sources. See *MULTI-ZONE remote controls* on page 64.

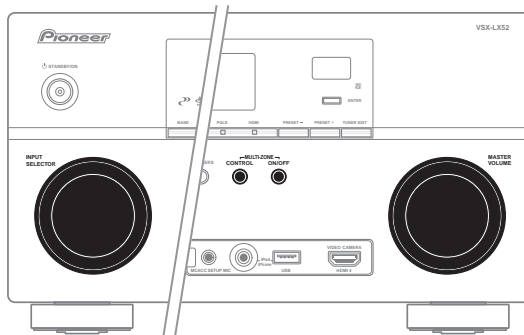

- 1 Press **MULTI-ZONE ON/OFF** on the front panel.

Each press selects a MULTI-ZONE option:

- **ZONE 2 ON** – Selects your primary (**ZONE 2**) sub zone
- **ZONE 2&3 ON** – Select both sub zones
- **ZONE 3 ON** – Selects your secondary (**ZONE 3**) sub zone
- **MULTI ZONE OFF** – Switches the MULTI-ZONE feature off

The **MULTI-ZONE** indicator lights when the MULTI-ZONE control has been switched ON.

- 2 Press **MULTI-ZONE CONTROL** on the front panel to select the sub zone(s) you want.

If you selected **ZONE 2&3 ON** above, you can toggle between **ZONE 2** and **ZONE 3**.

- When the receiver is on,² make sure that any operations for the sub zone are done while **ZONE** and your selected sub zone(s) show in the display. If this is not showing, the front panel controls affect the main zone only.

- 3 Use the **INPUT SELECTOR** dial to select the source for the zone you have selected.

For example, **ZONE 2 CD-R** sends the source connected to the **CD-R** inputs to the primary (**ZONE 2**) sub room.

- If you select **TUNER**, you can use the tuner controls to select a preset station (see *Saving station presets* on page 48 if you're unsure how to do this).³

Note

- 1 • The subwoofer output depends on the settings you made in *Manual speaker setup* on page 84. However, if **SP▶B** is selected above, no sound is heard from the subwoofer (the LFE channel is not downmixed).
 - Depending on the settings in *Surround back speaker setting* on page 85 output from the surround back pre-out terminals may change.
 - All speaker systems (except **Speaker B** connections) are switched off when headphones are connected.
- 2 If the receiver is in standby, the display is dimmed, and **ZONE** and your selected sub zone(s) continue to show in the display.
- 3 The tuner cannot be tuned to more than one station at a time. Therefore, changing the station in one zone also changes the station in the other zone. Please be careful not to change stations when recording a radio broadcast.

4 Use the MASTER VOLUME dial to adjust the volume for the zone you have selected.

This is only possible if you selected the **Variable** volume control in *ZONE Audio Setup* on page 89.¹

5 When you're finished, press MULTI-ZONE CONTROL again to return to the main zone controls.

You can also press **MULTI-ZONE ON/OFF** on the front panel to switch off all output to the sub zone(s).²

MULTI-ZONE remote controls

Set the MULTI-ZONE operation switch to **ZONE 2** or **ZONE 3** to operate the corresponding zone.

The following table shows the possible MULTI-ZONE remote controls:

Button	What it does
	Switches on/off power in the sub zone.
INPUT SELECT	Use to select the input function in the sub zone.
Input function buttons	Use to select the input function directly (this may not work for some functions) in the sub zone.
MASTER VOLUME +/-	Use to set the listening volume in the sub zone.

Making an audio or a video recording

You can make an audio or a video recording from the built-in tuner, or from an audio or video source connected to the receiver (such as a CD player or TV).³

Keep in mind you can't make a digital recording from an analog source or vice-versa, so make sure the components you are recording to/from are hooked up in the same way (see *Connecting your equipment* on page 14 for more on connections).

Since the video converter is not available when making recordings (from the video **OUT** jacks) make sure to use the same type of video cable for connecting your recorder as you used to connect your video source (the one you want to record) to this receiver. For example, you must connect your recorder using Component video if your source has also been connected using Component video.

For more information about video connections, see *Connecting an HDD/DVD recorder, VCR and other video sources* on page 27.

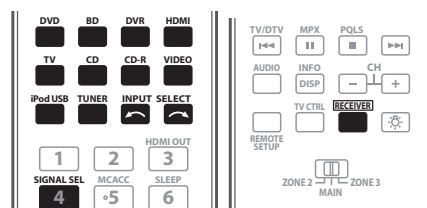

1 Select the source you want to record.

Use the input function buttons (or **INPUT SELECT**).

- If necessary, press **RECEIVER**, then press **SIGNAL SEL** to select the input signal corresponding to the source component (see *Choosing the input signal* on page 55 for more on this).

2 Prepare the source you want to record.

Tune to the radio station, load the CD, video, DVD etc.

3 Prepare the recorder.

Insert a blank tape, MD, video etc. into the recording device and set the recording levels.

Refer to the instructions that came with the recorder if you are unsure how to do this. Most video recorders set the audio recording level automatically—check the component's instruction manual if you're unsure.

4 Start recording, then start playback of the source component.

Reducing the level of an analog signal

The input attenuator lowers the input level of an analog signal when it's too strong. You can use this if you find that the **OVER** indicator lights often or you can hear distortion in the sound.⁴

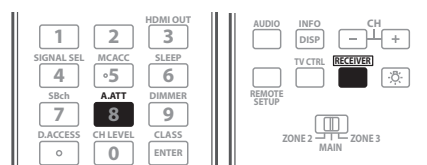

- Press **RECEIVER**, then press **A.ATT** to switch the input attenuator on or off.

Note

- The volume levels of the main and sub zones are independent.
- You won't be able to switch the main zone off completely unless you've switched off the MULTI-ZONE control first.
 - If you don't plan to use the MULTI-ZONE feature for a while, turn off the power in both the sub and main rooms so that this receiver is in standby.
- The receiver's volume, Audio parameters (the tone controls, for example), and surround effects have no effect on the recorded signal.
 - Some digital sources are copy-protected, and can only be recorded in analog.
 - Some video sources are copy-protected. These cannot be recorded.
- The attenuator isn't available with digital sources, or when using the Stream Direct (ANALOG DIRECT) modes.

Using the sleep timer

The sleep timer switches the receiver into standby after a specified amount of time so you can fall asleep without worrying about the receiver being left on all night. Use the remote control to set the sleep timer.

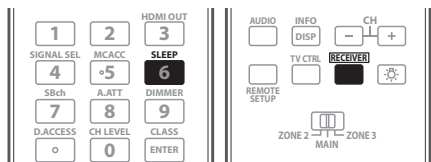

- Press **RECEIVER**, then press **SLEEP** repeatedly to set the sleep time.

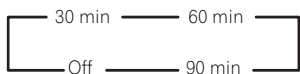

- You can check the remaining sleep time at any time by pressing **SLEEP** once. Pressing repeatedly will cycle through the sleep options again.¹

Dimming the display

You can choose between four brightness levels for the front panel display. Note that when selecting sources, the display automatically brightens for a few seconds.

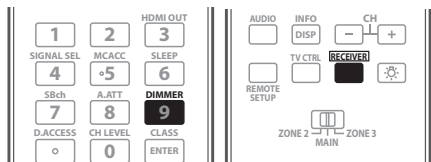

- Press **RECEIVER**, then press **DIMMER** repeatedly to change the brightness of the front panel display.

Switching the HDMI output

Set which terminal to use when outputting video and audio signals from the HDMI output terminals (**HDMI OUT ALL**, **HDMI OUT 1** or **HDMI OUT 2**).

The HDMI OUT1 terminal is compatible with the KURO LINK function.

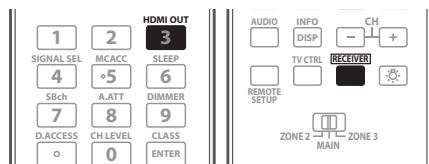

- Press **RECEIVER**, then press **HDMI OUT**. Please wait a while when **Please wait ...** is displayed.

The output switches among **HDMI OUT ALL**, **HDMI OUT 1** and **HDMI OUT 2** each time the button is pressed.²

Checking your system settings

Use the status display screen to check your current settings for features such as surround back channel processing and your current MCACC preset.

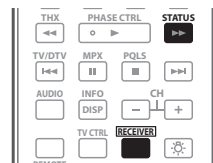

- 1 Press **RECEIVER**, then press **STATUS** to check the system settings.

These appear on the front panel display.³

The front panel display shows each of the following settings for three seconds each:

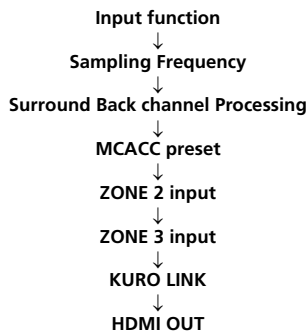

- 2 When you're finished, press **STATUS** again to switch off the display.

Note

- 1 You can also switch off the sleep timer simply by switching off the receiver.
- 2 The sleep timer is valid for all zones. If any zone is on, the sleep timer continues functioning.
- 2 *Synchronized amp mode* on page 59 is canceled when the HDMI output is switched. If you wish to use the synchronized amp mode, switch to **HDMI OUT 1**, then select the synchronized amp mode on the flat screen TV using the flat screen TV's remote control.
- When the power is turned off then back on after switching the HDMI output, the input is set to a setting between HDMI1 and HDMI3, or BD.
- 3 If the Pure Direct mode is switched on, some settings above will show **OFF**, even though they are on.

Resetting the system

Use this procedure to reset all the receiver's settings to the factory default. Use the front panel controls to do this. Set **MULTI-ZONE** to **OFF**.

- Disconnect the iPod and USB memory device from the receiver beforehand.

1 Switch the receiver into standby.

2 While holding down ENTER on the front panel, press \odot STANDBY/ON.

The display shows **RESET ◀ NO ▶**.

3 Select 'RESET' using PRESET +/-, then press ENTER on the front panel.

The display shows **RESET? OK**.

4 Press ENTER to confirm.

OK appears in the display to indicate that the receiver has been reset to the factory default settings.

- Note that all settings will be saved, even if the receiver is unplugged.

Default system settings

Setting	Default
Digital Video Conversion	ON
SPEAKERS	A
Surround Back System	Normal
Speaker System	Front
	Center
	Surr
	SB
	SW
Crossover	80 Hz
X-Curve	OFF
THX Audio Setting	1.2 m<
DIMMER	Medium bright
Inputs	
See <i>Input function default and possible settings</i> on page 41.	
MULTI-ZONE	
ZONE 2/3 Volume Level	Variable
ZONE 2/3 Volume	-60 dB
HDMI	
HDMI Audio	Amp
HDMI output	HDMI OUT ALL
KURO LINK	ON

Setting	Default
DSP	
Surround back channel Processing	ON
Phase Control	ON
Sound Retriever	iPod/USB function
	Other functions
Sound Delay	0.0 frame
Dual Mono	CH1
DRC	AUTO
SACD Gain	0 dB
LFE Attenuate	0 dB
Auto delay	OFF
Up Mix	ON
Digital Safety	OFF
Effect Level	ExtendedStereo
	Other modes
<input checked="" type="checkbox"/> PL II Music Options	Center Width
	Dimension
	Panorama
Neo:6 Options	Center Image
	Neo:6 MUSIC: 3
	Neo:6 CINEMA: 10
All Inputs	Listening Mode (2 ch)
	Listening Mode (x ch)
	Listening Mode (HP)
	STEREO
See also <i>Setting the Audio options</i> on page 60 for other default DSP settings.	
MCACC	
MCACC Position Memory	M1: MEMORY 1
Channel Level (M1 to M6)	0.0 dB
Speaker Distance (M1 to M6)	3.00 m
Standing Wave (M1 to M6)	ATT of all channels/ filters
	SWch Wide Trim
EQ Data (M1 to M6)	All channels/bands
	EQ Wide Trim

Chapter 9:

Controlling the rest of your system

Operating multiple receivers

The remote control included with this receiver can be used to operate up to three other receivers (of the same model as this receiver) in addition to this receiver. The receiver to be operated is switched by inputting the preset code to set the remote control setting.

- Set the remote modes on the receivers before using this function (see *Remote Control Mode Setup* on page 90).

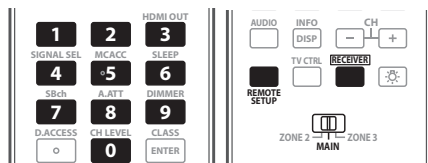

- Check the operation selector switch to **MAIN**.
- Press **RECEIVER**.
- Press and hold **REMOTE SETUP**, then release it after the LED flashes twice.
- Use the number buttons to enter the 5-digit preset code (see below).
 - Receiver 1: **6 1 9 3 5** (Default)
 - Receiver 2: **6 2 6 3 0**
 - Receiver 3: **6 2 6 3 1**
 - Receiver 4: **6 2 6 3 2**

When the preset code is fully input, the LED flashes once to indicate that the setting is completed.

To operate another receiver, start over from step 1 to input its preset code.

Setting the remote to control other components

Most components can be assigned to one of the input function buttons (such as **DVD** or **CD**) using the component's manufacturer preset code stored in the remote.

However, there are cases where only certain functions may be controllable after assigning the proper preset code, or the codes for the manufacturer in the remote control will not work for the model that you are using.

Note

- You can cancel or exit any of the steps by pressing **RECEIVER**. To go back a step, press **RETURN**.
- After one minute of inactivity, the remote automatically exits the operation.

Selecting preset codes directly

- Press the input function button for the component you want to control.¹

When assigning preset codes to **TV CONTROL**, press **TV CTRL** here.

- Press and hold **REMOTE SETUP**, then release it after the LED flashes twice.

- Use the number buttons to enter the 5-digit preset code.

See *Preset code list* on page 105.

When the preset code is fully input, the LED flashes once to indicate that the setting is completed.

- Repeat steps 1 through 3 for the other components you want to control.

To try out the remote control, switch the component on or off (into standby) by pressing **SOURCE**. If it doesn't seem to work, select the next code from the list (if there is one).

Note

¹ You can't assign **RECEIVER**, **TUNER** or **iPod/USB**.

Resetting the remote control presets

This will erase all preset remote control preset codes and programmed buttons.

- 1 Check the operation selector switch to **MAIN**.
- 2 Press **RECEIVER**.
- 3 Press and hold **REMOTE SETUP**, then release it after the LED flashes twice.
- 4 Use the number buttons to enter **9, 8, 1**.
The LED flashes four times to indicate that the resetting is completed.

Default preset codes

Input function button	Preset code
DVD	3 1 5 7 1
BD	3 2 4 4 2
DVR	2 2 3 0 6
HDMI	3 2 4 4 2
TV	1 3 0 0 0
CD	7 0 4 6 8
CD-R	7 1 0 8 7
VIDEO	2 0 0 5 8
TV CTRL	1 3 0 0 0
RECEIVER	6 1 9 3 5

Controls the components

This remote control can control components after entering the proper codes (see *Setting the remote to control other components* on page 67 for more on this). Use the input function buttons to select the component.

- The **TV CONTROL** buttons on the remote control are dedicated to control the TV assigned to the **TV CTRL** button. If you have two TVs, assign the main TV to the **TV CTRL** button.

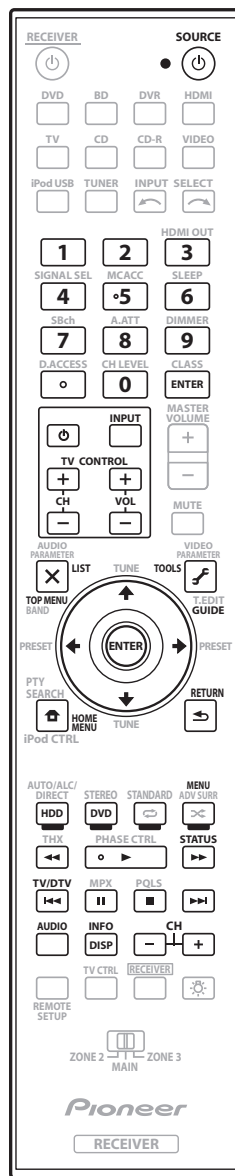

Button(s)	TV	TV (Monitor)	BD/DVD	HDD/DVR	VCR	SAT/CATV
SOURCE	POWER ON/OFF	POWER ON/OFF	POWER ON/OFF	POWER ON/OFF	POWER ON/OFF	POWER ON/OFF
Number buttons	<i>numerics</i>	<i>numerics</i>	<i>numerics</i>	<i>numerics</i>	<i>numerics</i>	<i>numerics</i>
• (dot)	• (dot)	KURO LINK	CLEAR	+	-	*
ENTER (CLASS)	ENTER	CH ENTER	ENTER	ENTER	-	ENTER
	EXIT/INFO	EXIT	TOP MENU	TOP MENU	-	LIST
	TOOLS/GUIDE/EPG	USER MENU	TOOLS	GUIDE	-	GUIDE
					-	
ENTER	ENTER	ENTER	ENTER	ENTER	-	ENTER
	HOME MENU	HOME MENU	HOME MENU	HOME MENU	-	HOME / MENU
	RETURN	RETURN	RETURN	RETURN	-	RETURN
HDD (Red)	<i>Red</i>	<i>Red</i>	-	HDD	-	<i>Red</i>
DVD (Green)	<i>Green</i>	<i>Green</i>	-	DVD	-	<i>Green</i>
(Yellow)	<i>Yellow</i>	<i>Yellow</i>	-	VCR	-	<i>Yellow</i>
(Blue)	<i>Blue</i>	<i>Blue</i>	MENU	MENU	-	<i>Blue</i>
	-	-				
	-	AUTO SETUP				
	-	FREEZE				
	-	-				
	-	-				
	TV/DTV	AV SELECTION			-	
	-	SCREEN SIZE			-	
AUDIO	AUDIO	AUDIO	AUDIO	AUDIO	AUDIO	AUDIO
DISP	DISPLAY	DISPLAY	DISPLAY	DISPLAY	-	DISPLAY/INFO
CH +/-	CH +/-	CH +/-	-	CH +/-	CH +/-	CH +/-
	-	-	-	-	-	RECORD

Button(s)	LD	CD/CD-R/SACD	MD/DAT	TAPE
SOURCE	POWER ON/OFF	POWER ON/OFF	POWER ON/OFF	POWER ON/OFF
Number buttons	<i>numerics</i>	<i>numerics</i>	<i>numerics</i>	-
• (<i>dot</i>)	+10	>10/CLEAR	CLEAR ^b	CLEAR
ENTER (CLASS)	ENTER	DISK/ENTER	OPEN/CLOSE ^b	ENTER
	TOP MENU	-	-	MS←
	-	LEGATO LINK ^a	-	MS→
		-	-	
ENTER	ENTER	-	-	-
	-	SACD SETUP ^a	-	-
	RETURN	-	-	-
AUDIO	AUDIO	PURE AUDIO ^a	-	-
DISP	DISPLAY/INFO	TIME ^a	-	-

a. Controls for SACD.

b. Controls for MD.

Button(s)	TV (Projector)
SOURCE	POWER ON
1	MOVIE
2	STANDARD
3	DYNAMIC
4	USER1
5	USER2
6	USER3
7	COLOR+
8	SHARP+
9	GAMMA
0	COLOR-
• (<i>dot</i>)	SHARP-
ENTER (CLASS)	COLOR TEMP
	EXIT
	INFO
ENTER	ENTER
	TEST
	HIDE
	MENU
	HDMI1
	HDMI2
	COMP.
	VIDEO
	S-VIDEO
	BRIGHT-
	BRIGHT+
AUDIO	POWER OFF
DISP	ASPECT
CH +/-	CONTRAST+/-

Chapter 10: The Advanced MCACC menu

Making receiver settings from the Advanced MCACC menu

The Advanced MCACC (Multi Channel Acoustic Calibration) system was developed in Pioneer's laboratories with the aim of making it possible for home users to perform adjustments of the same level as in a studio easily and with high precision. The acoustic characteristics of the listening environment are measured and the frequency response is calibrated accordingly to allow high precision, automatic analysis and optimal calibration of the sound field to bring it closer to a studio environment than ever before. Furthermore, while it was previously difficult to eliminate standing waves, this receiver is equipped with a standing wave control function using a unique process to perform acoustic analysis and reduce their influence.

This section describes how to calibrate the sound field automatically and fine-adjust the sound field data manually.

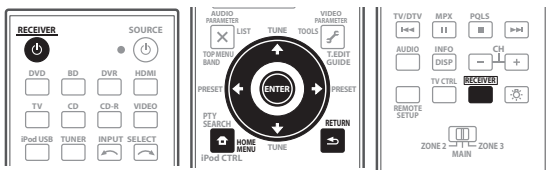

1 Switch on the receiver and your TV.

Use **RECEIVER** to switch on.¹

- If headphones are connected to the receiver, disconnect them.

2 Press **RECEIVER** on the remote control, then press **HOME MENU**.²

A Graphical User Interface (GUI) screen appears on your TV. Use **↑/↓/←/→** and **ENTER** to navigate through the screens and select menu items. Press **RETURN** to confirm and exit the current menu.

- Press **HOME MENU** at any time to exit the **HOME MENU**.

3 Select 'Advanced MCACC' from the **HOME MENU**, then press **ENTER**.

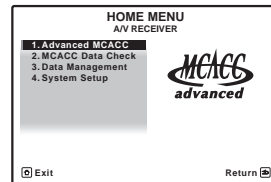

4 Select the setting you want to adjust.

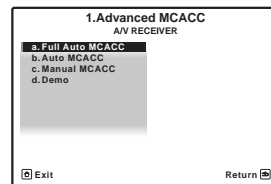

- **Full Auto MCACC** – See *Automatically setting up for surround sound (Auto MCACC)* on page 39 for a quick and effective automatic surround setup.
- **Auto MCACC** – See *Automatic MCACC (Expert)* on page 72 for a more detailed MCACC setup.
- **Manual MCACC** – Fine-tunes your speaker settings and customize the Acoustic Calibration EQ (see *Manual MCACC setup* on page 74).
- **Demo** – No settings are saved and no errors occur. When the speakers are connected to this receiver, the test tone is output repeatedly. Press **RETURN** to cancel the test tone.

Note

¹ Make sure not to switch off the power when using the **HOME MENU**.

² You can't use the **HOME MENU** when the iPod/USB input function is selected (in either the main or sub zone). When you set **ZONE 2**, **ZONE 3** or **ZONE 2&3** to **ON** (page 63), you can't use the **HOME MENU**.

Automatic MCACC (Expert)

If your setup requires more detailed settings than those provided in *Automatically setting up for surround sound (Auto MCACC)* on page 39, you can customize your setup options below. You can calibrate your system differently for up to six different MCACC presets¹, which are useful if you have different listening positions depending on the type of source (for example, watching movies from a sofa, or playing a video game close to the TV).²



Important

- Make sure the microphone/speakers are not moved during the Auto MCACC Setup.
- Using the Auto MCACC Setup will overwrite any existing settings for the MCACC preset you select.³
- The screen saver will automatically appear after five minutes of inactivity.



CAUTION

- The test tones used in the Auto MCACC Setup are output at high volume.

THX®

THX is a trademark of THX Ltd., which may be registered in some jurisdictions. All rights reserved.

1 Select 'Auto MCACC' from the Advanced MCACC menu, then press ENTER.

If the **Advanced MCACC** screen is not displayed, refer to *Making receiver settings from the Advanced MCACC menu* on page 71.

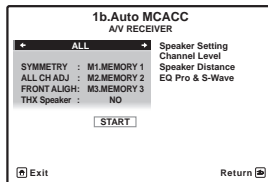
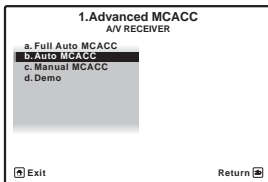

2 Select the parameters you want to set.

Use **↑/↓** to select the item, then use **←/→** to set.

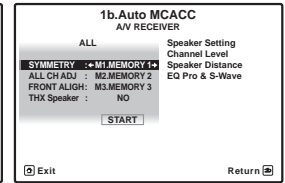
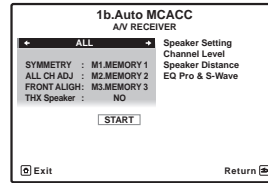

- **Auto MCACC** – The default is **ALL** (recommended), but you can limit the system calibration to only one setting (to save time) if you want.⁴ The available options are **ALL**, **Keep SP System**,⁵ **Speaker Setting**, **Channel Level**, **Speaker Distance** and **EQ Pro & S-Wave**.
- **EQ Type** (*only available when the Auto MCACC Menu above is EQ Pro & S-Wave*) – This determines how the frequency balance is adjusted.

After a single calibration is performed, each of the following three correction curves can be stored separately in the MCACC memory. **SYMMETRY** (default) implements symmetric correction for each pair of left and right speakers to flatten the frequency-amplitude characteristics. **ALL CH ADJ** is a 'flat' setting where all the speakers are set individually so no special weighting is given to any one channel. **FRONT ALIGN**⁶ sets all speakers in accordance with the front speaker settings (no equalization is applied to the front left and right channels).

- **THX Speaker** (*only available when the Auto MCACC Menu above is ALL or Speaker Setting*) – Select **YES** if you are using THX speakers (set all speakers to **SMALL**), otherwise leave it set to **NO**.
- **STAND.WAVE Multi-Point** (*only available when the Auto MCACC Menu above is EQ Pro & S-Wave*) – In addition to measurements at the listening position, you can use two more reference points for which test tones will be analyzed for standing waves. This is useful if you want to get a balanced 'flat' calibration for several seating positions in your listening area.⁷ Place the microphone at the reference point indicated on-screen and note *the last microphone placement will be at your main listening position*:

Note

- These are stored in memory and referred to as **MEMORY1** to **MEMORY6** until you rename them in *Data Management* on page 82.
- You may also want to have separate calibration settings for the same listening position, depending on how you're using your system.
- Except in cases where you are only adjusting one parameter (i.e. channel level) from the **Auto MCACC** menu (step 2).
- The **EQ Pro & S-Wave** measurement is also taken when **Keep SP System** or **EQ Pro & S-Wave** is selected. See *Acoustic Calibration EQ Professional* on page 77 for more on this.
 - Either effect of Acoustic Calibration EQ Professional and Standing Wave can be switched on and off in the respective MCACC preset. For details, see *Setting the Audio options* on page 60.
- The **Keep SP System** option allows you to calibrate your system while leaving your current speaker setting (page 85) unchanged.
- If you selected **ALL** as your **Auto MCACC** menu, you can specify the MCACC preset where you want to save the **ALL CH ADJ** and **FRONT ALIGN** settings.
- Switch the **Multi-Point** setting **NO** if you only use one listening position.

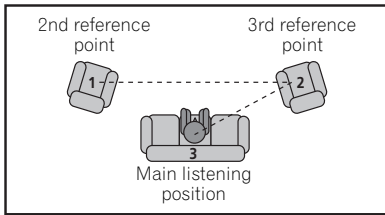

3 Connect the microphone to the MCACC SETUP MIC jack on the front panel.

- Push down on the **PUSH OPEN** tab to access the **MCACC SETUP MIC** jack.

Make sure there are no obstacles between the speakers and the microphone.

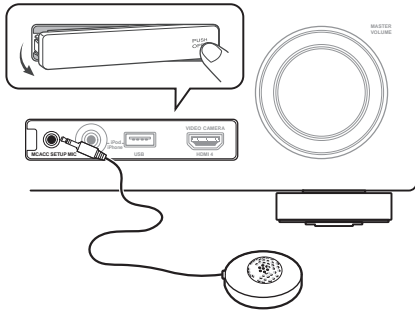

If you have a tripod, use it to place the microphone so that it's about ear level at your normal listening position. If you do not have a tripod, use some other object to install the microphone.¹

4 When you're finished setting the options, select **START** then press **ENTER**.

5 Follow the instructions on-screen.

- Make sure the microphone is connected.
- If you're using a subwoofer, it is automatically detected every time you switch on the system. Make sure it is on and the volume is turned up.
- See *Problems when using the Auto MCACC Setup* on page 40 for notes regarding high background noise levels and other possible interference.

6 Wait for the Auto MCACC Setup to finish outputting test tones.

A progress report is displayed on-screen while the receiver outputs test tones to determine the speakers present in your setup. Try to be as quiet as possible while it's doing this.

- Do not adjust the volume during the test tones. This may result in incorrect speaker settings.
- With error messages (such as **Too much ambient noise!** or **Check microphone**) select **RETRY** after checking for ambient noise (see *Problems when using the Auto MCACC Setup* on page 40) and verifying the mic connection. If there doesn't seem to be a problem, you can simply select **GO NEXT** and continue.

7 If necessary, confirm the speaker configuration in the GUI screen.²

The configuration shown on-screen should reflect the actual speakers you have.

If no operations are performed for 10 seconds while the speaker configuration check screen is being displayed, the Auto MCACC Setup will resume automatically. In this case, you don't need to select '**OK**' and press **ENTER** in step 8.

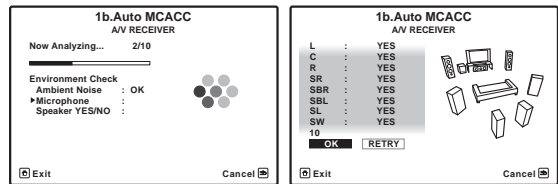

- If you see an **ERR** message (or the speaker configuration displayed isn't correct), there may be a problem with the speaker connection. If selecting **RETRY** doesn't work, turn off the power and check the speaker connections. If there doesn't seem to be a problem, you can simply use **↑/↓** to select the speaker and **←/→** to change the setting and continue.
- If **Reverse Phase** is displayed, the speaker's wiring (+ and -) may be inverted. Check the speaker connections.³
 - If the connections were wrong, turn off the power, disconnect the power cord, then reconnect properly. After this, perform the Full Auto MCACC procedure again.
 - If the connections were right, select **GO NEXT** and continue.

Note

1 It may not be possible to measure correctly if the microphone is placed on a table, sofa, etc.
 2 This screen is only shown if you selected **ALL** or **Speaker Setting** from the **Auto MCACC** menu.
 3 If the speaker is not pointed to the microphone (listening position) or when using speakers that affect the phase (dipole speakers, reflective speakers, etc.), **Reverse Phase** may be displayed even if the speakers are properly connected.

8 Make sure 'OK' is selected, then press ENTER.

A progress report is displayed on-screen while the receiver outputs more test tones to determine the optimum receiver settings for channel level, speaker distance, and Acoustic Calibration EQ.

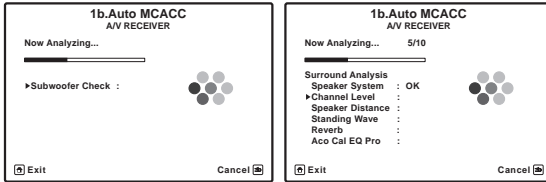

Again, try to be as quiet as possible while this is happening. It may take 3 to 7 minutes.

- If you selected a **STAND.WAVE Multi-Point** setup (in step 2), you will be asked to place the mic at the 2nd and 3rd reference points before finally placing it at your main listening position.

9 The Auto MCACC Setup procedure is completed and the Advanced MCACC menu reappears automatically.

The settings made in the Auto MCACC Setup should give you excellent surround sound from your system, but it is also possible to adjust these settings manually using the **Manual MCACC** setup menu (starting below) or **Manual SP Setup** menu (starting on page 84).¹

You can also choose to view the settings by selecting individual parameters from the **MCACC Data Check** screen:

- **Speaker Setting** – The size and number of speakers you've connected (see page 85 for more on this)
- **Channel Level** – The overall balance of your speaker system (see page 75 or 86 for more on this)
- **Speaker Distance** – The distance of your speakers from the listening position (see page 75 or 87 for more on this)²
- **Standing Wave** – Filter settings to control lower 'boomy' frequencies (see page 76 for more on this)
- **Acoustic Cal EQ** – Adjustments to the frequency balance of your speaker system based on the acoustic characteristics of your room (see page 77 for more on this)
- **Output PC** – The data transfer mode with the connected computer is set. The graphs of the reverb characteristics before and after calibration and the various MCACC parameters can be checked (see *Output PC* on page 81 for more on this).

Note

- Depending on the characteristics of your room, sometimes identical speakers with cone sizes of around 12 cm will end up with different size settings. You can correct the setting manually using the *Manual speaker setup* on page 84.
 - The subwoofer distance setting may be farther than the actual distance from the listening position. This setting should be accurate (taking delay and room characteristics into account) and generally does not need to be changed.
 - If Auto MCACC Setup measurement results are incorrect due to the interaction of the speakers and viewing environment, we recommend adjusting the settings manually.
- Since the distance measurements have been set according to the sound characteristics of your speakers, there are cases where (for optimal surround sound) the actual distance may differ from the speaker distance setting.

Press **RETURN** after you have finished checking each screen. When you're finished, select **RETURN** to go back to the **HOME MENU**.

Be sure to disconnect the microphone from this receiver upon completion of the Auto MCACC Setup.

Manual MCACC setup

You can use the settings in the **Manual MCACC** setup menu to make detailed adjustments when you're more familiar with the system. Before making these settings, you should have already completed *Automatically setting up for surround sound (Auto MCACC)* on page 39.

You only need to make these settings once (unless you change the placement of your current speaker system or add new speakers).

CAUTION

- The test tones used in the **Manual MCACC** setup are output at high volume.

Important

- You will need to first specify the MCACC preset you want to adjust by pressing **MCACC** before pressing **HOME MENU** (step 2 in *Making receiver settings from the Advanced MCACC menu* on page 71).
- For some of the settings below, you'll have to connect the setup microphone to the front panel and place it about ear level at your normal listening position. Press **HOME MENU** to display the **HOME MENU** before you connect the microphone to this receiver. If the microphone is connected while the **HOME MENU** is not being displayed, the display will change to the **Full Auto MCACC** under **Advanced MCACC**.
- See *Problems when using the Auto MCACC Setup* on page 40 for notes regarding high background noise levels and other possible interference.
- If you're using a subwoofer, switch it on and turn up the volume to the middle position.

1 Select 'Manual MCACC' from the Advanced MCACC menu.

See *Making receiver settings from the Advanced MCACC menu* on page 71 if you're not already at this screen.

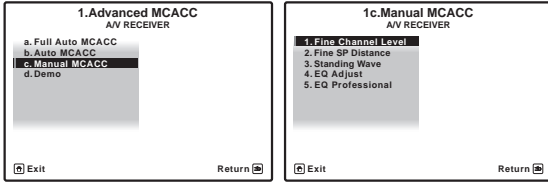

2 Select the setting you want to adjust.

If you're doing this for the first time, you might want to make these settings in order.

- **Fine Channel Level** – Make fine adjustments to the overall balance of your speaker system (see *Fine Channel Level* below).
- **Fine SP Distance** – Make precise delay settings for your speaker system (see *Fine Speaker Distance* below).
- **Standing Wave** – Control overly resonant low frequencies in your listening room (see *Standing Wave* on page 76).

The last two settings are specifically for customizing the parameters explained in *Acoustic Calibration EQ Adjust* on page 77:

- **EQ Adjust** – Manually adjust the frequency balance of your speaker system while listening to test tones (see *Acoustic Calibration EQ Adjust* on page 77).
- **EQ Professional** – Calibrate your system based on the direct sound coming from the speakers and make detailed settings according to your room's reverb characteristics (see *Acoustic Calibration EQ Professional* on page 77).

Fine Channel Level

- Default setting: **0.0dB** (all channels)

You can achieve better surround sound by properly adjusting the overall balance of your speaker system. You can adjust the Channel Level of each speaker in 0.5 dB increments. The following setting can help you make detailed adjustments that you may not achieve using the *Manual speaker setup* on page 84.

1 Select 'Fine Channel Level' from the Manual MCACC setup menu.

The volume increases to the 0.0 dB reference level.

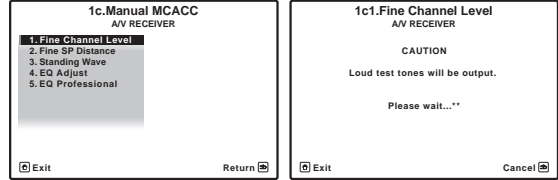

2 Adjust the level of the left channel.

This will be the reference speaker level, so you may want to keep the level around **0.0dB** so that you'll have plenty of room to adjust the other speaker levels.

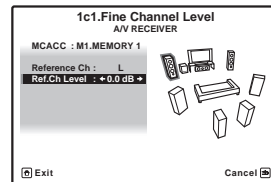

- After pressing **ENTER**, test tones will be output.

3 Select each channel in turn and adjust the levels (+/-10.0 dB) as necessary.

Use **←/→** to adjust the volume of the speaker you selected to match the reference speaker. When it sounds like both tones are the same volume, press **↓** to confirm and continue to the next channel.

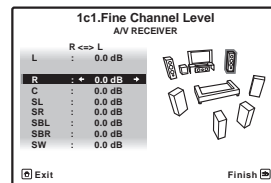

- For comparison purposes, the reference speaker will change depending on which speaker you select.
- If you want to go back and adjust a channel, simply use **↑/↓** to select it.

4 When you're finished, press RETURN.

You will return to the **Manual MCACC** setup menu.

Fine Speaker Distance

- Default setting: **3.00m** (all speakers)

For proper sound depth and separation with your system, it is necessary to add a slight bit of delay to some speakers so that all sounds will arrive at the listening position at the same time. You can adjust the distance of each speaker in 1 cm increments. The following setting can help you make detailed adjustments that you may not achieve using the *Manual speaker setup* on page 84.

1 Select 'Fine SP Distance' from the Manual MCACC setup menu.

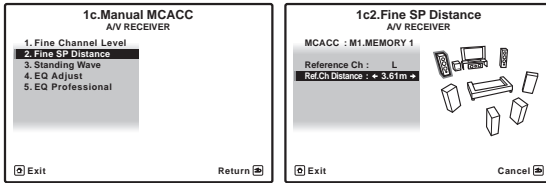

2 Adjust the distance of the left channel from the listening position.

3 Select each channel in turn and adjust the distance as necessary.

Use \leftarrow/\rightarrow to adjust the delay of the speaker you selected to match the reference speaker. The delay is measured in terms of speaker distance from **0.01m** to **9.00m**.

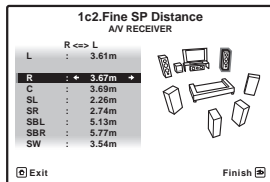

Listen to the reference speaker and use it to measure the target channel. From the listening position, face the two speakers with your arms outstretched pointing at each speaker. Try to make the two tones sound as if they are arriving simultaneously at a position slightly in front of you and between your arm span.¹

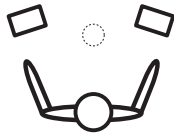

When it sounds like the delay settings are matched up, press \downarrow to confirm and continue to the next channel.

- For comparison purposes, the reference speaker will change depending on which speaker you select.
- If you want to go back and adjust a channel, simply use \uparrow/\downarrow to select it.

4 When you're finished, press RETURN.

You will return to the **Manual MCACC** setup menu.

Standing Wave

- Default setting: **ON²/ATT 0.0dB** (all filters)

Acoustic standing waves occur when, under certain conditions, sound waves from your speaker system resonate mutually with sound waves reflected off the walls in your listening area. This can have a negative effect on the overall sound, especially at certain lower frequencies. Depending on speaker placement, your listening position, and ultimately the shape of your room, it results in an overly resonant ('boomy') sound. The Standing Wave Control uses filters to reduce the effect of overly resonant sounds in your listening area. During playback of a source, you can customize the filters used for Standing Wave Control for each of your MCACC presets.³

1 Select 'Standing Wave' from the Manual MCACC setup menu.

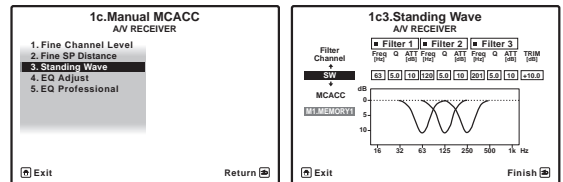

2 Adjust the parameters for the Standing Wave Control.

- **Filter Channel** – Select the channel to which you will apply the filter(s): **MAIN** (all except center channel and subwoofer), **Center** or **SW** (subwoofer).
- **TRIM** (only available when the filter channel above is **SW**) – Adjust the subwoofer channel level (to compensate for the difference in output post-filter).
- **Freq / Q / ATT** – These are the filter parameters where **Freq** represents the frequency you will be targeting and **Q** is the bandwidth (the higher the Q, the narrower the bandwidth, or range) of the attenuation (**ATT**, the amount of reduction to the targeted frequency).

3 When you're finished, press RETURN.

You will return to the **Manual MCACC** setup menu.

Note

- If you can't seem to achieve this by adjusting the distance setting, you may need to change the angle of your speakers very slightly.
- For better audibility, the subwoofer emits a continuous test tone (oscillating pulses are heard from your other speakers). Note that it may be difficult to compare this tone with the other speakers in your setup (depending on the low frequency response of the reference speaker).
- You can switch on or off the Standing Wave and Acoustic Calibration EQ feature in the **AUDIO PARAMETER** menu. See *Setting the Audio options* on page 60 for more on this.
- Since they will be overwritten, you may want to save the standing wave settings made with the Auto MCACC Setup to another MCACC preset.
- Standing Wave control filter settings cannot be changed during playback of sources using the HDMI connection.
- When **Standing Wave** is selected for an MCACC preset memory where **STAND.WAVE** is set to **OFF** in the **AUDIO PARAMETER**, **STAND.WAVE ON** is automatically selected.

Acoustic Calibration EQ Adjust

- Default setting: **ON**¹/**0.0dB** (all channels/bands)

Acoustic Calibration Equalization is a kind of room equalizer for your speakers (excluding the subwoofer). It works by measuring the acoustic characteristics of your room and neutralizing the ambient characteristics that can color the original source material (providing a 'flat' equalization setting). If you're not satisfied with the adjustment provided in *Automatically setting up for surround sound (Auto MCACC)* on page 39 or *Automatic MCACC (Expert)* on page 72, you can also adjust these settings manually to get a frequency balance that suits your tastes.

1 Select 'EQ Adjust' from the Manual MCACC setup menu.

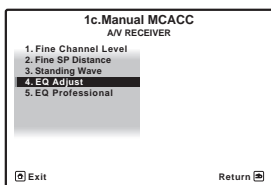

2 Select the channel(s) you want and adjust to your liking.

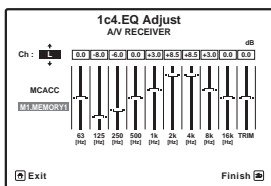

Use **↑/↓** to select the channel.

Use **←/→** to select the frequency and **↑/↓** to boost or cut the EQ. When you're finished, go back to the top of the screen and press **←** to return to **Ch**, then use **↑/↓** to select the channel.

- The **OVER!** indicator shows in the display if the frequency adjustment is too drastic and might distort. If this happens, bring the level down until **OVER!** disappears from the display.

Tip

- Changing the frequency curve of one channel too drastically will affect the overall balance. If the speaker balance seems uneven, you can raise or lower channel levels using test tones with the **TRIM** feature. Use **↑/↓** to select **TRIM**, then use **←/→** to raise or lower the channel level for the current speaker.

3 When you're finished, press RETURN.

You will return to the **Manual MCACC** setup menu.

Acoustic Calibration EQ Professional

This setup minimizes the unwanted effects of room reverberation by allowing you to calibrate your system based on the direct sound coming from the speakers. It can also provide you with a graphical output of the frequency response of your room.²

How to use Acoustic Calibration EQ Professional

If you find that lower frequencies seem overly reverberant in your listening room (i.e. it sounds 'boomy'), or that different channels seem to exhibit different reverb characteristics, select **EQ Pro. & S-Wave** (or **ALL**) for the **Auto MCACC** setting in *Automatic MCACC (Expert)* on page 72 to calibrate the room automatically. This should provide a balanced calibration that suits the characteristics of your listening room.

If you still aren't satisfied with the results, the manual **Advanced EQ Setup** (below) provides a more customized calibration of your system using the direct sound of the speakers. This is done with the help of a graphical output that can be displayed on-screen, or using a computer (with software available from Pioneer — see *Output PC* on page 81).

How to interpret the graphical output

The graph shows decibels on the vertical axis and time (in milliseconds) on the horizontal axis. A straight line indicates a flat-response room (no reverb), whereas a sloping line indicates the presence of reverberation when outputting test tones. The sloping line will eventually flatten out when the reverberant sound stabilizes (this usually takes about 100 ms or so).

By analyzing the graph, you should be able to see how your room is responding to certain frequencies. Differences in channel level and speaker distance are taken into account automatically (compensation is provided for comparison purposes), and the frequency measurements can be examined both with and without the equalization performed by this receiver.³

Note

- 1 When **EQ Adjust** is selected for an MCACC preset memory where **EQ** is set to **OFF** in the **AUDIO PARAMETER**, **EQ ON** is automatically selected.
- 2 This system allows you to customize your system calibration with the help of a graphical output that can be displayed on-screen, or using a computer (with software available from Pioneer—see *Output PC* on page 81 for more on this).
- 3 Note that due to an effect known as 'group delay', lower frequencies will take longer to be generated than higher frequencies (this is most obvious when comparing the frequencies at 0 ms). This initial slope is not a problem (i.e. excessive reverb) with your listening room.

Setting Acoustic Calibration EQ Professional according to your room characteristics

Using the manual setup, you can set the time period at which the frequency response is analyzed, pinpointing the time that is best for system calibration with your particular room characteristics.

The graph below shows the difference between conventional acoustic calibration and professional calibration (the gray circle indicates the point where the microphone captures sound during frequency analysis).

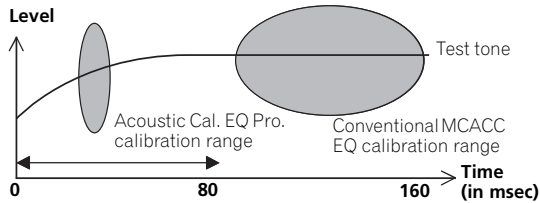

As soon as audio is output from your speaker system, it is influenced by room characteristics, such as walls, furniture, and the dimensions of the room. The sooner the frequency analysis, the less it is influenced by the room. We recommend an earlier time setting of **30~50ms** to compensate for two major factors that will influence the sound of most rooms:

- **Reverberance of high vs. low frequencies** – Depending on your room, you may find that lower frequencies seem overly reverberant compared to higher frequencies (i.e. your room sounds 'boomy'). This may result in a skewed frequency analysis if the measurement is done too late.

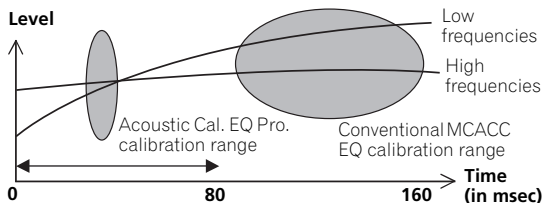

- **Reverb characteristics for different channels** – Reverb characteristics can be somewhat different for each channel. Since this difference increases as the sound is influenced by the various room characteristics, it is often better to capture a frequency analysis early on for smoother mixing of

channel frequencies/sounds.

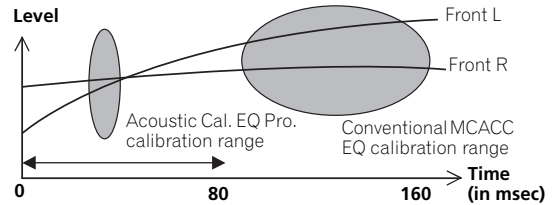

If your room isn't affected by the factors above, it is often not necessary to make a **30~50ms** setting. Later time settings may provide a more detailed sound experience with your speaker system. It is best to try and see what works best for your particular room.

Note that changing the room (for example, moving furniture or paintings) will affect the calibration results. In such cases, you should recalibrate your system.

Using Acoustic Calibration EQ Professional

1 Select 'EQ Professional', then press ENTER.

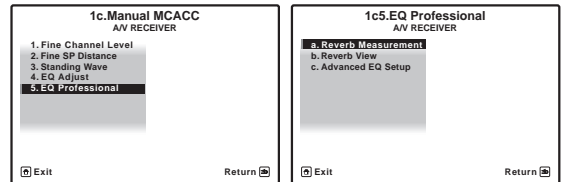

2 Select an option and press ENTER.

- **Reverb Measurement** – Use this to measure the reverb characteristics before and after calibration. (For graphical output using a PC, see *Connecting a PC for Advanced MCACC output* on page 34 to connect an RS-232C cable before selecting this option.)
- **Reverb View** – You can check the reverb measurements made for specified frequency ranges in each channel.¹ This can also be used to compare the reverb characteristics before and after calibration.²

Note

¹ If the **Reverb View** procedure is performed after the *Automatically setting up for surround sound (Auto MCACC)* on page 39 or **Reverb Measurement** operation, depending on the standing wave control setting, differences may appear on the reverb graph. With the Auto MCACC function, the reverberations are measured with the standing waves controlled, so the reverb characteristics graph shows the characteristics with the effect of the standing waves eliminated. By contrast, the **Reverb Measurement** function measures the reverberations without controlling the standing waves, so the graph indicates the reverb characteristics including the effect of the standing waves. If you wish to check the reverb characteristics of the room itself (with the standing waves as such), we recommend using the **Reverb Measurement** function.

² The reverb characteristics after calibration can be displayed even after performing the **Full Auto MCACC** function (*Automatically setting up for surround sound (Auto MCACC)* on page 39). In this case, the display shows the predicted reverb characteristics after calibration. If the measurements are taken using the Reverb Measurement command (page 79) with the equalizer on, the actually measured reverb characteristics after calibration are displayed.

- **Advanced EQ Setup** – Use this to select the time period that will be used for frequency adjustment and calibration, based on the reverb measurement of your listening area. Note that customizing system calibration using this setup will alter the settings you made in *Automatically setting up for surround sound (Auto MCACC)* on page 39 or *Automatic MCACC (Expert)* on page 72 and is not necessary if you're satisfied with these settings.

3 If you selected 'Reverb Measurement', select EQ ON or OFF, and then START.

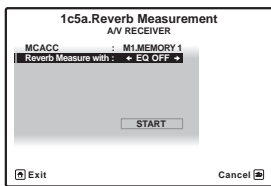

The following options determine how the reverb characteristics of your listening area are displayed in **Reverb View** and **Output PC** (see *Connecting a PC for Advanced MCACC output* on page 34):

- **EQ OFF** – You will see the reverb characteristics of your listening area *without* the equalization performed by this receiver (before calibration).
- **EQ ON** – You will see the reverb characteristics of your listening area *with* the equalization performed by this receiver (after calibration).¹ Note that the EQ response may not appear entirely flat due to adjustments necessary for your listening area.²

When the reverb measurement is finished, you can select **Reverb View** to see the results on-screen. See *Professional Calibration EQ graphical output* on page 96 for troubleshooting information.

4 If you selected 'Reverb View', you can check the reverb characteristics for each channel. Press RETURN when you're done.

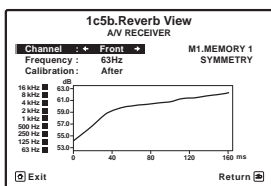

Note

- The calibration corresponding to the currently selected MCACC preset will be used when **EQ ON** is selected. To use another MCACC preset, exit the **HOME MENU** and press **MCACC** to select it before pressing **HOME MENU**.
- The predicted reverb characteristics after calibration can be acquired with the **Full Auto MCACC** function (*Automatically setting up for surround sound (Auto MCACC)* on page 39), but here the actually measured reverb characteristics after calibration can be acquired.
- After auto calibration with **EQ Type : SYMMETRY (Full Auto MCACC, etc.)**, the graph for the inferred reverb characteristics can be displayed by selecting **Reverb View**. To display the actually measured reverb characteristics after EQ calibration, measure with **EQ ON**.
- The **After** display when measurements have been made using the **Full Auto MCACC** or **Auto MCACC (ALL)** function shows the graph for the inferred reverb characteristics after **EQ Type : SYMMETRY** calibration.
- The reverb characteristics graph is overwritten each time the reverberations are measured. **No Data** is displayed if there is no reverb characteristic data, for example before measurements have been taken.

The reverb characteristics are displayed when the **Full Auto MCACC** or **Reverb Measurement** measurements are conducted.³

Use **←/→** to select the channel, frequency and calibration setting you want to check. Use **↑/↓** to go back and forth between the three. The reverb characteristics graph before and after EQ calibration can be displayed by selecting **Calibration : Before / After**.⁴ Note that the markers on the vertical axis indicate decibels in 2 dB steps.

5 If 'Advanced EQ Setup' is selected, select the MCACC memory to be stored, then enter the desired time setting for calibration, and then select START.

Based on the reverb measurement above, you can choose the time period that will be used for the final frequency adjustment and calibration. Even though you can make this setting without reverb measurement, it is best to use the measurement results as a reference for your time setting. For an optimal system calibration based on the direct sound coming from the speakers, we recommend using the **30-50ms** setting.

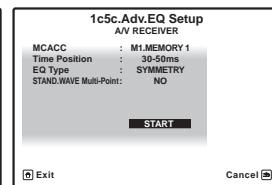
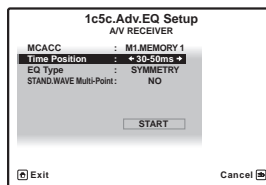

Use **←/→** to select the setting. Use **↑/↓** to switch between them.

Select the setting from the following time periods (in milliseconds): **0-20ms, 10-30ms, 20-40ms, 30-50ms, 40-60ms, 50-70ms** and **60-80ms**. This setting will be applied to all channels during calibration.

When you're finished, select **START**. It will take about 2 to 4 minutes for the calibration to finish.

After the Acoustic Calibration Equalization is set, you are given the option to check the settings on-screen.

Checking MCACC Data

At the procedure of *Automatically setting up for surround sound (Auto MCACC)* on page 39, the procedure of *Automatic MCACC (Expert)* on page 72 or after fine-adjusting at *Manual MCACC setup* on page 74, you can check your calibrated settings using the GUI screen or, if a computer is connected, on the computer's screen.

1 Press **RECEIVER**, then press **HOME MENU**.

A Graphical User Interface (GUI) screen appears on your TV. Use **↑/↓/←/→** and **ENTER** to navigate through the screens and select menu items. Press **RETURN** to confirm and exit the current menu.

2 Select 'MCACC Data Check' from the **HOME MENU**.

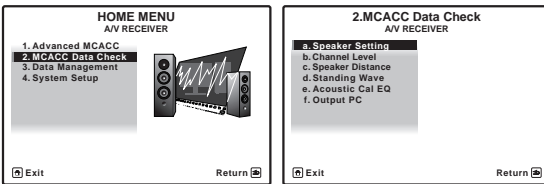

3 Select the setting you want to check.

- **Speaker Setting** – Used to check the settings of the speaker systems. See *Speaker Setting* below for more on this.
- **Channel Level** – Used to check the output level of the different speakers. See *Channel Level* below for more on this.
- **Speaker Distance** – Used to check the distance to the different speakers. See *Speaker Distance* below for more on this.
- **Standing Wave** – Used to check the standing wave control filter settings. See *Standing Wave* on page 81 for more on this.
- **Acoustic Cal EQ** – Used to check the calibration values of the listening environment's frequency response. See *Acoustic Cal EQ* on page 81 for more on this.
- **Output PC** – See *Output PC* on page 81 for more on this.

4 Press **RETURN** to go back to MCACC Data Check menu, repeating steps 2 and 3 to check other settings.

5 When you're finished, press **RETURN**.

You will return to the **HOME MENU**.

Speaker Setting

Use this to display the speaker size and number of speakers. See *Speaker Setting* on page 85 for more on this.

1 Select 'Speaker Setting' from the MCACC Data Check menu.

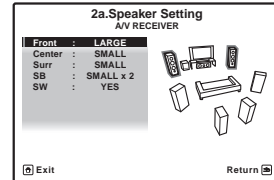

2 Select the channel you want to check.

Use **↑/↓** to select the channel. The corresponding channel on the layout diagram is highlighted.

Channel Level

Use this to display the level of the various channels. See *Channel Level* on page 86 for more on this.

1 Select 'Channel Level' from the MCACC Data Check menu.

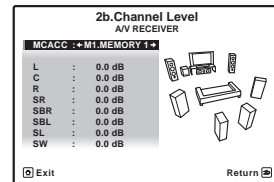

2 When 'MCACC' is highlighted, use **←/→** to select the MCACC preset you want to check.

The level of the various channels set at the selected MCACC preset is displayed. '---' is displayed for channels that are not connected.

Speaker Distance

Use this to display the distance from the different channels to the listening position. See *Speaker Distance* on page 87 for more on this.

1 Select 'Speaker Distance' from the MCACC Data Check menu.

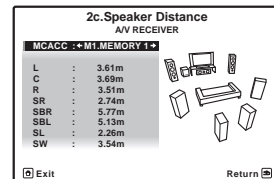

2 When 'MCACC' is highlighted, use **←/→** to select the MCACC preset you want to check.

The distance from the various channels set at the selected MCACC preset is displayed. '---' is displayed for channels that are not connected.

Standing Wave

Use this to display the standing wave related adjustment values for the various MCACC memories. See *Standing Wave* on page 76 for more on this.

- 1 Select 'Standing Wave' from the MCACC Data Check menu.

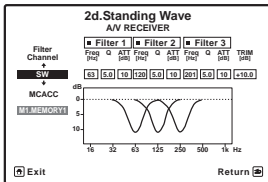

- 2 When 'Filter Channel' is highlighted, use ↑/↓ to select the channel for which you want to check standing wave control.

The standing wave related calibration value for the selected channel stored at the selected MCACC preset and its graph are displayed.

- 3 Press ← to highlight 'MCACC', then use ↑/↓ to select the MCACC preset you want to check.

Acoustic Cal EQ

Use this to display the calibration values for the frequency response of the various channels set in the different MCACC presets. See *Acoustic Calibration EQ Adjust* on page 77 for more on this.

- 1 Select 'Acoustic Cal EQ' from the MCACC Data Check menu.

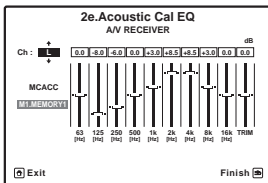

- 2 When 'Ch' is highlighted, use ↑/↓ to select the channel.

The calibration value for the frequency response of the selected channel stored at the selected MCACC preset and its graph are displayed.

- 3 Press ← to highlight 'MCACC', then use ↑/↓ to select the MCACC preset you want to check.

Output PC

Before continuing, make sure you have completed step 2 in *Checking MCACC Data* on page 80. The data measured with the Advanced MCACC function is transmitted to the connected computer.¹ The 3D graphs of the reverb characteristics before and after calibration and the MCACC results (parameters) can be checked.

- 1 Select 'Output PC' from MCACC Data Check menu and press ENTER.

When the receiver is ready for transmission, **Start the MCACC application on your PC** shows on the GUI screen.

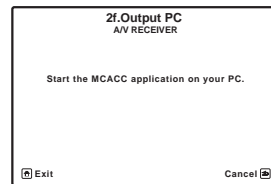

- 2 Start the MCACC application on your computer.

Follow the instructions provided with the application. It will take about ten seconds for the transmission to complete, then you will be able to analyze the output on your computer. The various parameters and the reverb characteristics data used for display on the computer are not cleared when the power is turned off. If the reverb characteristics are re-measured, however, the data is overwritten.²

- 3 When you're finished, press RETURN.

You will return to the **MCACC Data Check** menu. Continue with other operations in the **MCACC Data Check** menu if necessary. Press RETURN again to exit the **MCACC Data Check** menu.

Note

1 To transmit data, the receiver and computer must be connected using an RS-232C cable and a special application must be installed on the computer. See *Connecting a PC for Advanced MCACC output* on page 34 for more on this.

2 Only one set of reverb characteristics is stored on the receiver. If you wish to compare several different measurement results, transmit the data to the computer each time reverb measurements are taken.

Data Management

This system allows you to store up to six MCACC presets, allowing you to calibrate your system for different listening positions (or frequency adjustments for the same listening position).¹ This is useful for alternate settings to match the kind of source you're listening to and where you're sitting (for example, watching movies from a sofa, or playing a video game close to the TV).

From this menu you can copy from one preset to another, name presets for easier identification and clear any ones you don't need.

1 Press **RECEIVER**, then press **HOME MENU**.

A Graphical User Interface (GUI) screen appears on your TV. Use **↑/↓/←/→** and **ENTER** to navigate through the screens and select menu items. Press **RETURN** to confirm and exit the current menu.

2 Select 'Data Management' from the HOME MENU.

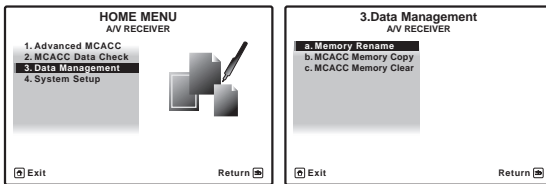

3 Select the setting you want to adjust.

- **Memory Rename** – Name your MCACC presets for easy identification (see *Renaming MCACC presets* below).
- **MCACC Memory Copy** – Copy settings from one MCACC preset to another (see *Copying MCACC preset data* below).
- **MCACC Memory Clear** – Clear any MCACC presets that you don't want (see *Clearing MCACC presets* on page 83).

Renaming MCACC presets

If you have several different MCACC presets that you're using, you may want to rename them for easier identification.

1 Select 'Memory Rename' from the Data Management setup menu.

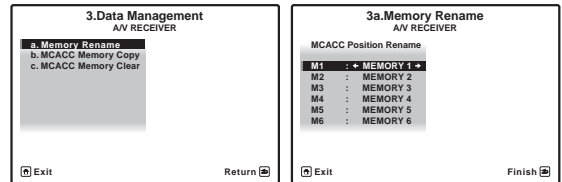

2 Select the MCACC preset you want to rename, then select an appropriate preset name.

Use **↑/↓** to select the preset, then **←/→** to select a preset name.

3 Repeat for as many MCACC presets as necessary, then press **RETURN** when you're finished.

You will return to the **Data Management** setup menu.

Copying MCACC preset data

If you want to manually adjust the Acoustic Calibration EQ (see *Manual MCACC setup* on page 74), we recommend copying your current settings² to an unused MCACC preset. Instead of just a flat EQ curve, this will give you a reference point from which to start.

1 Select 'MCACC Memory Copy' from the Data Management setup menu.

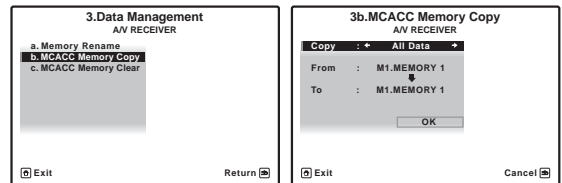

2 Select the setting you want to copy.

- **All Data** – Copies all the settings of the selected MCACC preset memory.
- **Level & Distance** – Copies only the channel level and speaker distance settings of the selected MCACC preset memory.

3 Select the MCACC preset you'll be copying the settings 'From', then specify where you want to copy them ('To').

Make sure you don't overwrite an MCACC preset you're currently using (this can't be undone).

Note

¹ This can be done in *Automatically setting up for surround sound (Auto MCACC)* on page 39 or *Automatic MCACC (Expert)* on page 72, either of which you should have already completed.

² The settings made in *Automatically setting up for surround sound (Auto MCACC)* on page 39 or *Automatic MCACC (Expert)* on page 72.

4 Select 'OK' to confirm and copy the settings.

When **MCACC Memory Copy?** is displayed, select **YES**. If **NO** is selected, the memory is not copied.

Completed! shows in the GUI screen to confirm the MCACC preset has been copied, then you automatically return to the **Data Management** setup menu.

Clearing MCACC presets

If you are no longer using one of the MCACC presets stored in memory, you can choose to clear the calibration settings of that preset.

1 Select 'MCACC Memory Clear' from the Data Management setup menu.

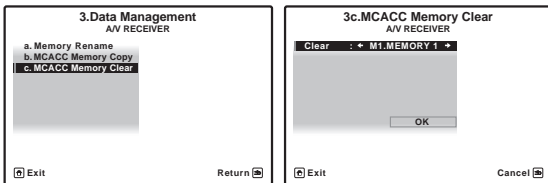

2 Select the MCACC preset you want to clear.

Make sure you don't clear an MCACC preset you're currently using (this can't be undone).

3 Select 'OK' to confirm and clear the preset.

When **MCACC Memory Clear?** is displayed, select **YES**. If **NO** is selected, the memory is not cleared.

Completed! shows in the GUI screen to confirm the MCACC preset has been cleared, then you automatically return to the **Data Management** setup menu.

Chapter 11:

The system and the other setup

Making receiver settings from the System Setup menu

The following section describes how to change the speaker-related settings manually and make various other settings (input selection, OSD language selection, etc.).

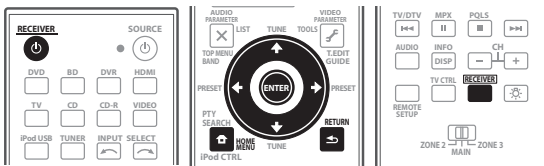

1 Switch on the receiver and your TV.

Use the **RECEIVER** button to switch on.¹

- If headphones are connected to the receiver, disconnect them.

2 Press **RECEIVER**, then press **HOME MENU**.²

A Graphical User Interface (GUI) screen appears on your TV. Use **↑/↓/←/→** and **ENTER** to navigate through the screens and select menu items. Press **RETURN** to confirm and exit the current menu.

- Press **HOME MENU** at any time to exit the **HOME MENU**.

3 Select 'System Setup' from the **HOME MENU**, then press **ENTER**.

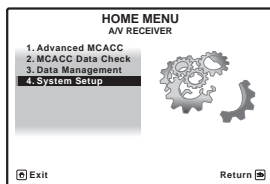

4 Select the setting you want to adjust.

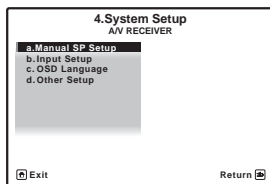

- **Manual SP Setup** – Sets the type of connection used for surround back terminals and the size, number distance and overall balance of the connected speakers (see *Manual speaker setup* below).
- **Input Setup** – Specifies what you've connected to the digital, HDMI and component video inputs (see *The Input Setup menu* on page 40).
- **OSD Language** – The GUI screen's display language can be changed (see *Changing the OSD display language (OSD Language)* on page 38).
- **Other Setup** – Makes customized settings to reflect how you are using the receiver (see *The Other Setup menu* on page 88).

Manual speaker setup

This receiver allows you to make detailed settings to optimize the surround sound performance. You only need to make these settings once (unless you change the placement of your current speaker system or add new speakers).

These settings are designed to customize your system, but if you're satisfied with the settings made in *Automatically setting up for surround sound (Auto MCACC)* on page 39, it isn't necessary to make all of these settings.

⚠ CAUTION

- The test tones used in the **Manual SP Setup** are output at high volume.

1 Select 'Manual SP Setup', then press **ENTER**.

See *Making receiver settings from the System Setup menu* above if you're not already at this screen.

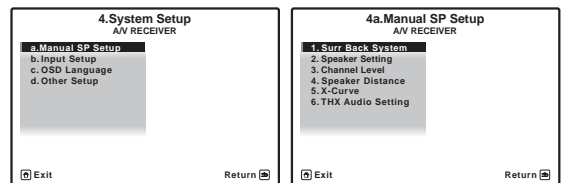

2 Select the setting you want to adjust.

If you are doing this for the first time, you may want to adjust these settings in order:

Note

¹ Make sure not to switch off the power when using the System Setup menu.

² You can't use the **HOME MENU** when either the iPod/USB input function is selected or the headphones are connected. When you set **ZONE 2, ZONE 3** or **ZONE 2&3** to **ON** (page 63), you can't use the **HOME MENU**.

- **Surr Back System** – Specifies how you are using your surround back speakers (see below).
- **Speaker Setting** – Specifies the size and number of speakers you've connected (see below).
- **Channel Level** – Adjusts the overall balance of your speaker system (page 86).
- **Speaker Distance** – Specifies the distance of your speakers from the listening position (page 87).
- **X-Curve** – Adjusts the tonal balance of your speaker system for movie soundtracks (page 87).
- **THX Audio Setting** – Specifies whether you are using a THX speaker setup (page 87).

3 Make the adjustments necessary for each setting, pressing RETURN to confirm after each screen.

Surround back speaker setting

- Default setting: **Normal**

There are several ways you can use the surround back speaker channels with this system. In addition to a normal home theater setup where they are used for the surround back speakers, they can be used for bi-amping the front speakers or as an independent speaker system in another room.

1 Select 'Surr Back System' from the Manual SP Setup menu.

See *Making receiver settings from the System Setup menu* on page 84 if you're not already at this screen.

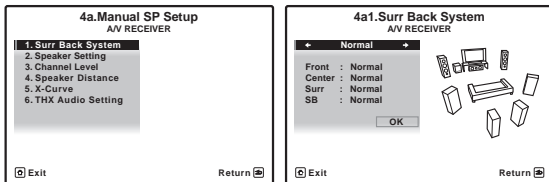

2 Select the surround back speaker setting.

- **Normal** – Select for normal home theater use with surround back speakers in your main (speaker system A) setup.
- **Speaker B** – Select to use the (surround back) B speaker terminals to listen to stereo playback in another room (see *Switching the speaker system* on page 63).
- **Front Bi-Amp** – Select this setting if you're bi-amping your front speakers (see *Bi-amping your speakers* on page 20).
- **ZONE 2** – Select to use the (surround back) B speaker terminals for an independent system in another zone (see *Using the MULTI-ZONE controls* on page 63).

Note

1 If you're using a THX speaker setup, set all speakers to **SMALL**.

2 If you select **SMALL** for the front speakers the subwoofer will automatically be fixed to **YES**. Also, the center, surround and surround back speakers can't be set to **LARGE** if the front speakers are set to **SMALL**. In this case, all bass frequencies are sent to the subwoofer.

3 When 'Setting Change?' is displayed, select Yes. If No is selected, the setting is not changed.

You will return to the **Manual SP Setup** menu.

Speaker Setting

Use this setting to specify your speaker configuration (size, number of speakers and crossover frequency)¹. It is a good idea to make sure that the settings made in *Automatically setting up for surround sound (Auto MCACC)* on page 39 are correct. Note that this setting applies to all MCACC presets, and cannot be set independently.

1 Select 'Speaker Setting' from the Manual SP Setup menu.

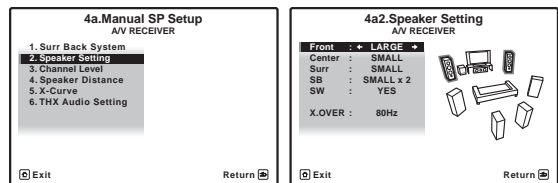

2 Choose the set of speakers that you want to set, then select a speaker size.

Use **←/→** to select the size (and number) of each of the following speakers:²

- **Front** – Select **LARGE** if your front speakers reproduce bass frequencies effectively, or if you didn't connect a subwoofer. Select **SMALL** to send the bass frequencies to the subwoofer.
- **Center** – Select **LARGE** if your center speaker reproduces bass frequencies effectively, or select **SMALL** to send bass frequencies to the other speakers or subwoofer. If you didn't connect a center speaker, choose **NO** (the center channel is sent to the front speakers).
- **Surr** – Select **LARGE** if your surround speakers reproduce bass frequencies effectively. Select **SMALL** to send bass frequencies to the other speakers or subwoofer. If you didn't connect surround speakers choose **NO** (the sound of the surround channels is sent to the front speakers or a subwoofer).

- **SB** – Select the number of surround back speakers you have (one, two or none).¹ Select **LARGE_{x2}** or **LARGE_{x1}** if your surround back speakers reproduce bass frequencies effectively. Select **SMALL_{x2}** or **SMALL_{x1}** to send bass frequencies to the other speakers or subwoofer. If you didn't connect surround back speakers choose **NO**.
- **SW** – LFE signals and bass frequencies of channels set to **SMALL** are output from the subwoofer when **YES** is selected. Choose the **PLUS** setting if you want the subwoofer to output bass sound continuously or you want deeper bass (the bass frequencies that would normally come out the front and center speakers are also routed to the subwoofer).² If you did not connect a subwoofer choose **NO** (the bass frequencies are output from other speakers).

3 Select 'X. OVER' and set the crossover frequency.³
Frequencies below this point will be sent to the subwoofer (or **LARGE** speakers).

4 When you're finished, press RETURN.
You will return to the **Manual SP Setup** menu.

Channel Level

Using the channel level settings, you can adjust the overall balance of your speaker system, an important factor when setting up a home theater system.

1 Select 'Channel Level' from the Manual SP Setup menu.

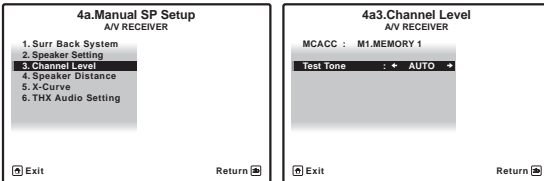

2 Select a setup option.

- **MANUAL** – Move the test tone manually from speaker to speaker and adjust individual channel levels.
- **AUTO** – Adjust channel levels as the test tone moves from speaker to speaker automatically.

3 Confirm your selected setup option.

The test tones will start after you press **ENTER**.

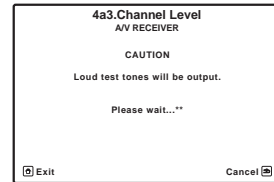

4 Adjust the level of each channel using ←/→.

If you selected **MANUAL**, use **↑/↓** to switch speakers. The **AUTO** setup will output test tones in the order shown on-screen:

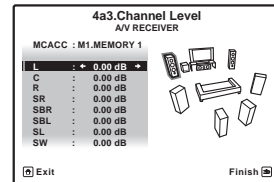

Adjust the level of each speaker as the test tone is emitted.⁴

5 When you're finished, press RETURN.

You will return to the **Manual SP Setup** menu.

Tip

- You can change the channel levels at any time by press **RECEIVER**, then press **CH LEVEL**, and then using **←/→** on the remote control.

Note

- If you selected **Speaker B. ZONE 2** or **Front Bi-Amp** (in *Surround back speaker setting* on page 85) you can't adjust the surround back settings.
 - If the surround speakers are set to **NO**, the surround back speakers will automatically be set to **NO**.
 - If you select one surround back speaker only, make sure that speaker is hooked up to the left surround back terminal.
- If you have a subwoofer and like lots of bass, it may seem logical to select **LARGE** for your front speakers and **PLUS** for the subwoofer. This may not, however, yield the best bass results. Depending on the speaker placement of your room you may actually experience a decrease in the amount of bass due low frequency cancellations. In this case, try changing the position or direction of speakers. If you can't get good results, listen to the bass response with it set to **PLUS** and **YES** or the front speakers set to **LARGE** and **SMALL** alternatively and let your ears judge which sounds best. If you're having problems, the easiest option is to route all the bass sounds to the subwoofer by selecting **SMALL** for the front speakers.
- This setting decides the cutoff between bass sounds playing back from the speakers selected as **LARGE**, or the subwoofer, and bass sounds playing back from those selected as **SMALL**. It also decides where the cutoff will be for bass sounds in the LFE channel.
 - If you're using a THX speaker setup, confirm that the crossover frequency is set to **80Hz**.
- If you are using a Sound Pressure Level (SPL) meter, take the readings from your main listening position and adjust the level of each speaker to 75 dB SPL (C-weighting/slow reading).
 - The subwoofer test tone is output at low volumes. You may need to adjust the level after testing with an actual soundtrack.

Speaker Distance

For good sound depth and separation from your system, you need to specify the distance of your speakers from the listening position. The receiver can then add the proper delay needed for effective surround sound.

1 Select 'Speaker Distance' from the Manual SP Setup menu.

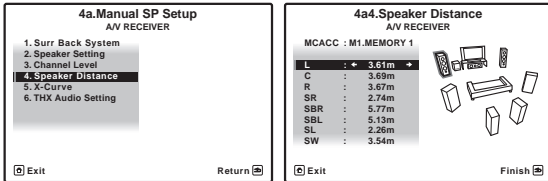

2 Adjust the distance of each speaker using ←/→.

You can adjust the distance of each speaker in 0.01 m increments.

3 When you're finished, press RETURN.

You will return to the **Manual SP Setup** menu.



Tip

- For best surround sound, make sure the surround back speakers are the same distance from the listening position.

X-Curve

Most soundtracks mixed for cinema sound too bright when played back in large rooms. The X-Curve setting acts as a kind of re-equalization for home theater listening, and restores proper tonal balance of movie soundtracks.¹

1 Select 'X-Curve' from the Manual SP Setup menu.

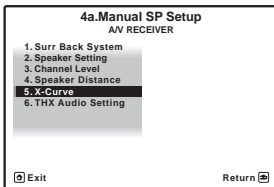

2 Choose the X-Curve setting you want.

Use ←/→ to adjust the setting. The X-Curve is expressed as a downwards slope in decibels per octave, starting at 2 kHz. The sound becomes less bright as the slope increases (to a maximum of **-3.0dB/oct**). Use the following guidelines to set the X-Curve according to your room size:

Room size (m ²)	≤36	≤48	≤60	≤72	≤300	≤1000
X-Curve (dB/oct)	-0.5	-1.0	-1.5	-2.0	-2.5	-3.0

- If you select **OFF**, the frequency curve will be flat and the X-Curve has no effect.

3 When you're finished, press RETURN.

THX Audio Setting

When the THX Loudness Plus function is used, sound can be played with the full surround effect even when the volume is low.

For the most effective results when using the THX Select2 Cinema, THX Select2 Music Mode and THX Select2 Games Mode listening modes (see *Using the Home THX modes* on page 51) with the Advanced Speaker Array (ASA) system (see *About THX* on page 102), it is required that you make the setting. See *Placing the speakers* on page 17 for more on THX speaker placement.²

With some speaker setups, depending on the position of the subwoofer and the walls in your listening area, you may experience overly resonant frequencies in the bass. If you have this problem use the THX Select2 subwoofer setup to switch on BGC (boundary gain compensation) (see *About THX* on page 102 for more on this).³

1 Select 'THX Audio Setting' from the Manual SP setup menu.

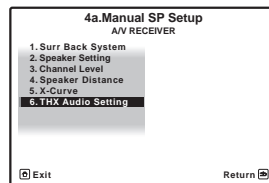

Note

- 1 Since the principal is the same, X-Curve isn't applied when you're using any of the Home THX modes (see *Using the Home THX modes* on page 51).
- 2 If you don't have surround back speakers, or just have one, you won't be able to select this setting.
- 3 • **THX Select2 SW** can only be selected when **SW** at **Speaker Setting** is set to **YES** or **PLUS**.
 - The BGC setting can only be selected when **THX Select2 SW** is set to **YES**.

2 Select either ON or OFF for THX Loudness Plus setting.

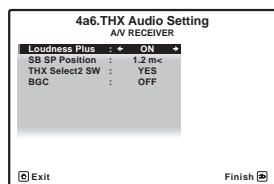

3 Specify the distance of your surround back speakers from each other.

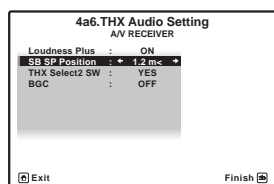

- **0–0.3 m** – Surround back speakers within 30 cm apart (best for THX surround sound).
- **>0.3– 1.2 m** – Surround back speakers between 30 cm and 1.2 m apart.
- **1.2 m<** – Surround back speakers more than 1.2 m apart (default).

4 Specify whether your subwoofer is THX Select2 certified or not.

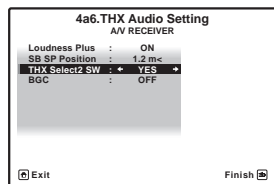

If your subwoofer isn't THX Select2 certified, but you still want to switch boundary gain compensation on, select **YES** here, but the effect might not work properly.

5 Select either ON or OFF for Boundary Gain Compensation setting.

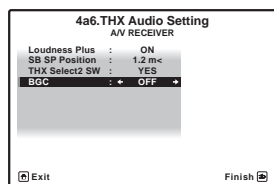

6 When you're finished, press RETURN. You will return to the **Manual SP Setup** menu.

The Other Setup menu

The **Other Setup** menu is where you can make customized settings to reflect how you are using the receiver.

1 Press **RECEIVER** on the remote control, then press **HOME MENU**.

A Graphical User Interface (GUI) screen appears on your TV. Use **↑/↓/←/→** and **ENTER** to navigate through the screens and select menu items. Press **RETURN** to confirm and exit the current menu.

2 Select 'System Setup' from the HOME MENU.

3 Select 'Other Setup', then press ENTER.

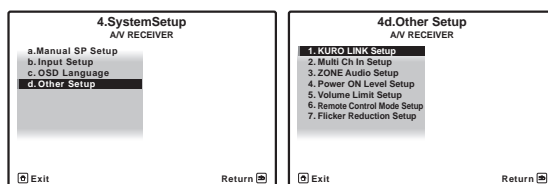

4 Select the setting you want to adjust.

If you are doing this for the first time, you may want to adjust these settings in order:

- **KURO LINK Setup** – Synchronizes this receiver with your Pioneer component supporting KURO LINK (see *KURO LINK Setup* on page 58).
- **Multi Ch In Setup** – Specifies the optional settings for a multi-channel input (page 89).
- **ZONE Audio Setup** – Specifies the volume setting for a MULTI-ZONE setup (page 89).
- **Power ON Level Setup** – Specifies the volume level set when the power is turned on (page 90).
- **Volume Limit Setup** – Limits the maximum volume (page 90).
- **Remote Control Mode Setup** – Sets this receiver's remote control mode (page 90).
- **Flicker Reduction** – Adjusts the way the GUI screen looks (page 90).

5 Make the adjustments necessary for each setting, pressing RETURN to confirm after each screen.

Multi Channel Input Setup

You can adjust the level of the subwoofer for a multi-channel input. Also, when the multi-channel input is selected as an input function, you can display the video images of other input functions. In the Multi Channel Input Setup, you can assign a video input to the multi-channel input.

1 Select 'Multi Ch In Setup' from the Other Setup menu.

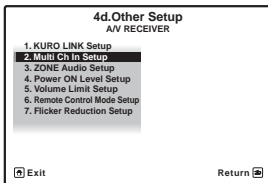

2 Select the 'SW Input Gain' setting you want.

- **0dB** – Outputs sound of the subwoofer at the level originally recorded on the source.
- **+10dB** – Outputs sound of the subwoofer at the level increased by 10 dB.

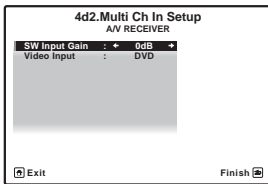

3 Select the 'Video Input' setting you want.

When the multi-channel input is selected as an input function, you can display the video images of other input functions. The video input can be selected from the following: **DVD**, **TV/SAT**, **DVR**, **VIDEO**, **OFF**.

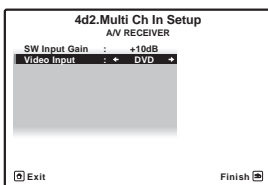

4 When you're finished, press RETURN.

You will return to the **Other Setup** menu.

ZONE Audio Setup

If you've made MULTI-ZONE connections (see *Using the MULTI-ZONE controls* on page 63), you may need to specify your volume setting.

1 Select 'ZONE Audio Setup' from the Other Setup menu.

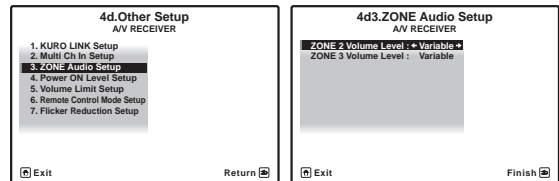

2 Select the volume level setting of ZONE 2 and ZONE 3.¹

- **Variable** – Use this setting if you've connected a power amplifier in the sub room (this receiver is simply being used as a pre-amp) and you will be using this receiver's controls to adjust the volume.
- **Fixed** – Use this setting if you've connected a fully integrated amplifier (such as another Pioneer VSX receiver) in the sub room and want to use that receiver's volume controls.

With the **Fixed** setting, the source is sent from this receiver at maximum volume, so make sure the volume is quite low in the sub zone at first, and then experiment to find the correct level.

3 When you're finished, press RETURN.

You will return to the **Other Setup** menu.

Note

¹ If you selected **ZONE 2** in the *Surround back speaker setting* on page 85, you won't be able to change the volume level.

Power ON Level Setup

The volume can be set so that it is always set to the same level when the receiver's power is turned on.

- 1 Select 'Power ON Level Setup' from the Other Setup menu.

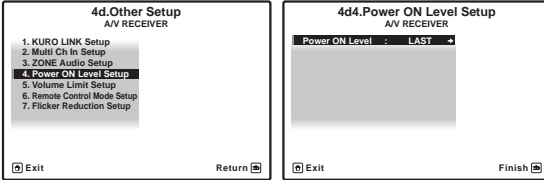

- 2 Select the Power ON Level setting you want.
 - **LAST** – When the power is turned on, the volume is set to the same level as when the power was last turned off.
 - **"---**" – When the power is turned on, the volume is set to minimum level.
 - **-80.0dB to +12.0dB** – Specify the volume to be set when the power is turned, in steps of 0.5 dB.

It is not possible to set a volume level greater than the value specified at Volume Limit Setup.

- 3 When you're finished, press RETURN. You will return to the Other Setup menu.

Volume Limit Setup

Use this function to limit the maximum volume. The volume cannot be increased above the level set here, even by operating **MASTER VOLUME** button (or the dial on the front panel).

- 1 Select 'Volume Limit Setup' from the Other Setup menu.

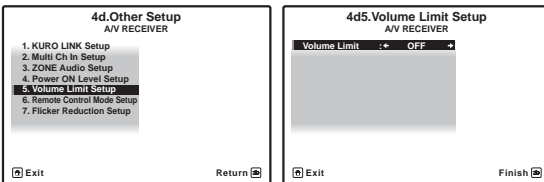

- 2 Select the Volume Limit setting you want.
 - **OFF** – The maximum volume is not limited.
 - **-20.0dB/-10.0dB/0.0dB** – The maximum volume is limited to the value set here.

- 3 When you're finished, press RETURN. You will return to the Other Setup menu.

Remote Control Mode Setup

- Default setting: 1

This sets this receiver's remote control mode to prevent erroneous operation when multiple units of the receiver are being used.¹

- 1 Select 'Remote Control Mode Setup' from the Other Setup menu.

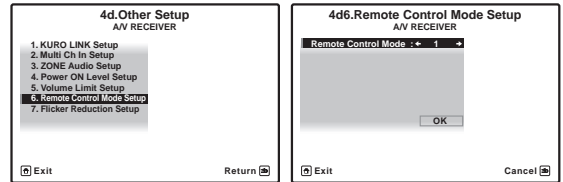

- 2 Select the Remote Control Mode setting you want.
- 3 Select "OK" to change the remote control mode.
- 4 Follow the instructions on the screen to change the remote control's setting. See *Operating multiple receivers* on page 67.
- 5 When you're finished, press RETURN. You will return to the Other Setup menu.

Flicker Reduction Setup

- Default setting: 4

The GUI screen's resolution can be increased. If you feel the GUI screen is hard to see, try changing this setting. Note that the resolution in this setting only affects the GUI screen; it has no influence on the video output.

- 1 Select 'Flicker Reduction Setup' from the Other Setup menu.

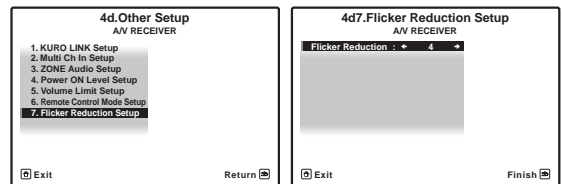

- 2 Select the Flicker Reduction setting you want.
- 3 When you're finished, press RETURN. You will return to the Other Setup menu.

Note

¹ If you change this receiver's setting, also change the setting on the remote control.

Chapter 12: Additional information

Speaker Setting Guide

In order to achieve an even better surround effect, it is important to accurately position the speakers and make their volume and tone characteristics uniform so as to finely focus the multi-channel sound.

The three major elements in positioning the speakers are **distance**, **angle** and **orientation** (the direction in which the speakers are pointing).

Distance: The distance of all the speakers should be equal.

Angle: The speakers should be horizontally symmetrical.

Orientation: The orientation should be horizontally symmetrical.

In most homes, however, it is not possible to achieve this environment. For the distance, on this receiver it is possible to automatically correct the speaker distance electrically to a precision of 1 cm using the Auto MCACC Setup function (page 39).

Step 1: Speaker layout and distance adjustment

Use speaker stands or the like to make sure the speakers are steady, and leave at least 10 cm from the surrounding walls. Position the speakers attentively so that the speakers on the left and right are at equal angles from the listening position (center of the adjustments). (We recommend using cords, etc., when adjusting the layout.) Ideally all the speakers should be equidistant from the listening position.



Tip

- If the speakers cannot be set at equal distances (on a circle), use the Auto MCACC Setup speaker distance correction and Fine Speaker Distance functions to make them equalize the distance artificially.

Step 2: Adjusting the speaker height

Adjust the heights (angles) of the different speakers.

Adjust so that the front speaker units reproducing mid- and high frequencies is roughly at the height of the ears. If the center speaker cannot be set at the same height as the front speakers, adjust its angle of elevation to point it to the listening position.

Set surround speaker 1 so that it is not under the height of the ears.

Step 3: Adjusting the speaker orientation

If the left and right speakers are not pointing in the same direction, the tone will not be the same on the right and left, and as a result the sound field will not be reproduced properly. However, if all the speakers are pointed towards the listening position, the sound field will seem cramped. Testing by the Pioneer Multi-channel Research Group has shown that a good sense of sound positioning can be achieved by pointing all the speakers towards an area 30 cm to 80 cm behind the listening position (between the surround speakers and the listening position).

However, the sense of sound positioning can differ according to the conditions in the room and the speakers being used. In smaller environments in particular (when the front speakers are close to the listening position), with this method the speakers will be pointed too inward. We suggest you use this example of installation as reference when trying out different installation methods.

Step 4: Positioning and adjusting the subwoofer

Placing the subwoofer between the center and front speakers makes even music sources sound more natural (If there is only one subwoofer, it doesn't matter if it is placed on the left or right side). The low bass sound output from the subwoofer is not directional and there is no need to adjust the height. Normally the subwoofer is placed on the floor. Put it in a position at which it will not cancel out the bass sound output from the other speakers. Also note that placing it near a wall may result in sympathetic vibrations with the building that could excessively amplify the bass sound.

If the subwoofer must be installed near a wall, place it at an angle so that it is not parallel to the wall surface. This can help reduce any sympathetic vibrations, but depending on the shape of the room this could result in standing waves. However, even if standing waves are generated, their influence on the sound quality can be prevented using the Auto MCACC's standing wave control function (page 81).

Step 5: Default settings with the Auto MCACC Setup (auto sound field correction) function

It is more effective to perform the Auto MCACC Setup (page 39) procedure once the adjustments described above have been completed.



Tip

- The distance to the subwoofer may be slightly larger than the distance actually measured with a tape measure, etc. This is because this distance is corrected for electric delay, and is not a problem.

Positional relationship between speakers and monitor

Position of front speakers and monitor

The front speakers should be as equidistant as possible to the monitor.

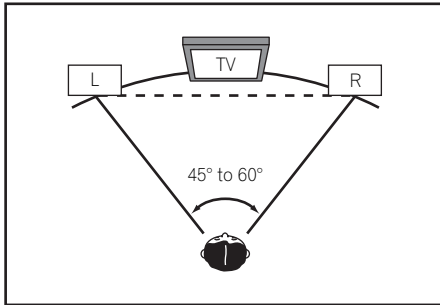

Position of center speaker and monitor

Since mostly dialogs are output from the center speaker, keeping the center speaker as close as possible to the screen makes the overall sound more natural. For TVs using Braun tubes, however, when installing the center speaker on the floor, adjust its angle of elevation to point it towards the listening position.

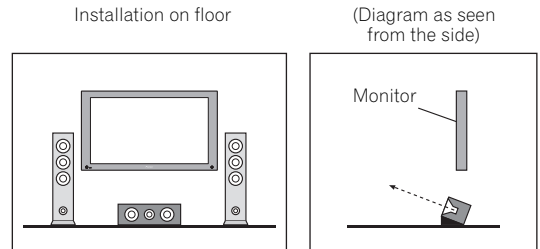

- If the center speaker is not of the shielded type, install it away from the TV.
- When installing the center speaker on top of the monitor, place it facing slightly downwards towards the listening position.

Troubleshooting

Incorrect operations are often mistaken for trouble and malfunctions. If you think that there is something wrong with this component, check the points below. Sometimes the trouble may lie in another component. Investigate the other components and electrical appliances being used. If the trouble cannot be rectified even after exercising the checks listed below, ask your nearest Pioneer authorized independent service company to carry out repair work.



Note

- If the unit does not operate normally due to external effects such as static electricity disconnect the power plug from the outlet and insert again to return to normal operating conditions.

Power

Symptom	Remedy
The power does not turn on.	<ul style="list-style-type: none"> • Make sure that the power cord is plugged in to an active power outlet. • Try disconnecting from the power outlet, then plugging back in.
Power cannot be turned off. (ZONE 2 ON or ZONE 3 ON is displayed.)	<ul style="list-style-type: none"> • Set the remote control's MULTI-ZONE operation selector switch to ZONE 2 or ZONE 3, then press RECEIVER to switch the sub zone off.
The receiver suddenly switches off or the PHASE CONTROL indicator blinks.	<ul style="list-style-type: none"> • Check that there are no loose strands of speaker wire touching the rear panel or another set of wires. If so, re-attach the speaker wires, making sure there are no stray strands. • The receiver may have a serious problem. Disconnect from the power and call a Pioneer authorized independent service company.
During loud playback the power suddenly switches off.	<ul style="list-style-type: none"> • Turn down the volume. • Lower the 63 Hz and 125 Hz equalizer levels in the <i>Manual MCACC setup</i> on page 74. • Switch on the digital safety feature. While holding down ENTER on the front panel, press STANDBY/ON to set this receiver to the standby mode. Use TUNE +/- to select D.SAFETY <OFF>, and then use PRESET +/- to select 1 or 2 (select D.SAFETY <OFF> to deactivate this feature). If the power switches off even with 2 switched on, turn down the volume. With 1 or 2 on, some features may be unavailable.
The unit does not respond when the buttons are pressed.	<ul style="list-style-type: none"> • Try switching the receiver off, then back on again. • Try disconnecting the power cord, then connect again.

Symptom	Remedy
AMP ERR blinks in the display, then the power automatically switches off. The ADVANCED MCACC blinks and the power does not turn on.	<ul style="list-style-type: none"> The receiver may have a serious problem. Do not try switching the receiver on. Contact a Pioneer authorized independent service company for help.
The ADVANCED MCACC indicator flashes and power turns off.	<ul style="list-style-type: none"> There is a problem with the receiver's power unit or fan. Try turning on the power after 1 minute. If the same thing happens, the receiver is damaged. Unplug the receiver from the wall and call a Pioneer authorized independent service company. (Other symptoms may appear when the power is turned on.)
AMP OVERHEAT and the power indicator flash and the power turns off.	<ul style="list-style-type: none"> Allow the unit to cool down in a well-ventilated place before switching back on. Wait at least 1 minute, then try turning the power on again.
The Receiver suddenly power off or the blue indicator at the center of the receiver flashes.	<ul style="list-style-type: none"> The power unit is damaged. Unplug the receiver from the wall and call a Pioneer authorized independent service company.
Display blinks 12V TRG ERR .	<ul style="list-style-type: none"> An error has arisen in the 12 V trigger jacks. Reconnect accurately then turn the power back on.

No sound

Symptom	Remedy
No sound is output when an input function is selected. No sound output from the front speakers.	<ul style="list-style-type: none"> Check the volume, mute setting (press MUTE) and speaker setting (press SPEAKERS). Make sure the correct input function is selected. Check that the MCACC setup microphone is disconnected. Make sure the correct input signal is selected (press SIGNAL SEL). Note that when PCM is selected, you won't be able to hear any other signal format. Check that the source component is connected properly (see <i>Connecting your equipment</i> on page 14). Check that the speakers are connected properly (see <i>Connecting the speakers</i> on page 18).
No sound from the surround or center speakers.	<ul style="list-style-type: none"> Check that the Stereo listening mode or the Front Stage Surround Advance mode isn't selected; select one of the surround listening modes (see <i>Listening in surround sound</i> on page 50). Check that the surround/center speakers are not set to NO (see <i>Speaker Setting</i> on page 85). Check the channel level settings (see <i>Channel Level</i> on page 86). Check the speaker connections (see <i>Connecting the speakers</i> on page 18).
No sound from surround back speakers.	<ul style="list-style-type: none"> Check that the surround back speakers are set to LARGE or SMALL (see <i>Speaker Setting</i> on page 85). Make sure surround back channel processing is set to SBch ON (see <i>Using surround back channel processing</i> on page 53). If the source is Dolby Surround EX or DTS-ES with no flag to indicate 6.1 compatibility, then with surround back channel processing set to SBch Auto, there will be no sound from the surround back speakers. In this case, set to SBch ON (see <i>Using surround back channel processing</i> on page 53). If the source does not have 6.1 playback channels, make sure that surround back channel processing is set to SBch ON and a surround mode is selected (see <i>Listening in surround sound</i> on page 50). Check the speaker connections (see <i>Connecting the speakers</i> on page 18). <p>If only one surround back speaker is connected, make sure it's connected to the left channel speaker terminal.</p>
No sound from subwoofer.	<ul style="list-style-type: none"> Check that the subwoofer is connected properly, switched on and the volume turned up. If your subwoofer has a sleep function, make sure it is switched off. Make sure that the Subwoofer setting is YES or PLUS (see <i>Speaker Setting</i> on page 85). The crossover frequency may be set too low; try setting it higher to match the characteristics of your other speakers (see <i>Speaker Setting</i> on page 85). If there is very little low frequency information in the source material, change your speaker settings to Front: SMALL / Subwoofer: YES, or Front: LARGE / Subwoofer: PLUS (see <i>Speaker Setting</i> on page 85). Check that the LFE channel is not set to OFF, or a very quiet setting (see <i>Setting the Audio options</i> on page 60). Check the speaker level settings (see <i>Channel Level</i> on page 86).

Symptom	Remedy
No sound from one speaker.	<ul style="list-style-type: none"> • Check the speaker connection (see <i>Connecting the speakers</i> on page 18). • Check the speaker level settings (see <i>Channel Level</i> on page 86). • Check that the speaker hasn't been set to NO (see <i>Speaker Setting</i> on page 85). • The channel may not be recorded in the source. By using one of the advanced effect listening mode, you may be able to create the missing channel (see <i>Listening in surround sound</i> on page 50).
Sound is produced from analog components, but not from digital ones (DVD, LD, CD-ROM, etc.).	<ul style="list-style-type: none"> • Check that the input signal type is set to DIGITAL (see <i>Choosing the input signal</i> on page 55). • Make sure that the digital input is assigned correctly for the input jack the component is connected to (see <i>The Input Setup menu</i> on page 40). • Check the digital output settings on the source component. • If the source component has a digital volume control, make sure this is not turned down. • Make sure that the multichannel analog inputs are not selected. Select any other input function.
No sound is output or a noise is output when Dolby Digital/DTS software is played back.	<ul style="list-style-type: none"> • Check that your DVD player is compatible with Dolby Digital/DTS discs. • Check the digital output settings of your DVD player. Make sure that the DTS signal output is set to On. • If the source component has a digital volume control, make sure this is not turned down.
No sound when using the HOME MENU .	<ul style="list-style-type: none"> • If the HDMI input function is selected, sound is muted until exiting the HOME MENU.

Other audio problems

Symptom	Remedy
Broadcast stations cannot be selected automatically, or there is considerable noise in radio broadcasts.	<p><i>For FM broadcasts</i></p> <ul style="list-style-type: none"> • Fully extend the FM wire antenna, adjust the position for best reception and secure to a wall, etc. • Use an outdoor antenna for better reception (see page 30). <p><i>For AM broadcasts</i></p> <ul style="list-style-type: none"> • Adjust the position and direction of the AM antenna. • Use an outdoor antenna for better reception (see page 30). • Noise may be caused by interference from other equipment, such as a fluorescent light, motor, etc. Switch off or move the other equipment, or move the AM antenna.
A multichannel DVD source appears to be downmixed to 2 channels during playback.	<ul style="list-style-type: none"> • Make sure that the multichannel analog inputs are selected (see <i>Selecting the multichannel analog inputs</i> on page 43).
Noise is output when scanning a DTS CD.	<ul style="list-style-type: none"> • This is not a malfunction of the receiver. The scan function of your player alters the digital information, making it unreadable, resulting in noise being output. Lower the volume when scanning.
When playing a DTS format LD there is audible noise on the soundtrack.	<ul style="list-style-type: none"> • Make sure that the input signal type is set to DIGITAL (see <i>Choosing the input signal</i> on page 55).
Can't record audio.	<ul style="list-style-type: none"> • You can only make a digital recording from a digital source, and an analog recording from an analog source. • For digital sources, make sure that what you're recording isn't copy protected. • Check that the OUT jacks are properly connected to the recorders input jacks (see <i>Connecting other audio components</i> on page 28).
Subwoofer output is very low.	<ul style="list-style-type: none"> • To route more signal to the subwoofer, set it to PLUS or set the front speakers to SMALL (see <i>Speaker Setting</i> on page 85).
Everything seems to be set up correctly, but the playback sound is odd.	<ul style="list-style-type: none"> • The speakers may be out of phase. Check that the positive/negative speaker terminals on the receiver are matched with the corresponding terminals on the speakers (see <i>Connecting the speakers</i> on page 18).
The PHASE CONTROL feature doesn't seem to have an audible effect.	<ul style="list-style-type: none"> • If applicable, check that the lowpass filter switch on your subwoofer is off, or the lowpass cutoff is set to the highest frequency setting. If there is a PHASE setting on your subwoofer, set it to 0° (or depending on the subwoofer, the setting where you think it has the best overall effect on the sound). • Make sure the speaker distance setting is correct for all speakers (see <i>Speaker Distance</i> on page 87).
Noise or hum can be heard even when there is no sound being input.	<ul style="list-style-type: none"> • Check that personal computers or other digital components connected to the same power source are not causing interference.

Symptom	Remedy
There seems to be a time lag between the speakers and the output of the subwoofer.	<ul style="list-style-type: none"> See <i>Automatically setting up for surround sound (Auto MCACC)</i> on page 39 to set up your system again using MCACC (this will automatically compensate for a delay in the subwoofer output).
The maximum volume available (shown in the front panel display) is lower than the +12dB maximum.	<ul style="list-style-type: none"> Check that the Volume Limit is set to OFF (see <i>Volume Limit Setup</i> on page 90).

Video

Symptom	Remedy
No image is output when an input is selected.	<ul style="list-style-type: none"> Check the video connections of the source component (see page 27). For HDMI, or when digital video conversion is set to OFF and a TV and another component are connected with different cords (in <i>Setting the Video options</i> on page 61), you must connect your TV to this receiver using the same type of video cable as you used to connect your video component. Make sure the input assignment is correct for components connected using component video, HDMI or S-Video cables (see <i>The Input Setup menu</i> on page 40). Check the video output settings of the source component. Check that the video input you selected on your TV is correct. Some components (such as video game units) have resolutions that may not be converted. If adjusting this receiver's Resolution setting (in <i>Setting the Video options</i> on page 61) and/or the resolution settings on your component or display doesn't work, try switching Digital Video Conversion (in <i>Setting the Video options</i> on page 61) OFF.
Can't record video.	<ul style="list-style-type: none"> Check that the source is not copy-protected. The video converter is not available when making recordings. Check that the same type of video cable is used for connecting both the recorder and the video source (the one you want to record) to this receiver.
Noisy, intermittent, or distorted picture.	<ul style="list-style-type: none"> Sometimes a video deck may output a noisy video signal (during scanning, for example), or the video quality may just be poor (with some video game units, for example). The picture quality may also depend on the settings, etc. of your display device. Switch off the video converter and reconnect the source and display device using the same type of connection (component, S-Video or composite), then start playback again.
Video signals are not output from the component terminal.	<ul style="list-style-type: none"> When a monitor only compatible with resolutions of 480i is connected to the component terminal and another monitor is connected to the HDMI terminal, the video signals may not be output to the monitor connected to the component terminal. If this happens, do the following: <ul style="list-style-type: none"> Turn off the power of the monitor connected to the HDMI terminal. Set RES on the VIDEO PARAMETER menu to PURE (page 61).

Settings

Symptom	Remedy
The Auto MCACC Setup continually shows an error.	<ul style="list-style-type: none"> The ambient noise level may be too high. Keep the noise level in the room as low as possible (see also <i>Problems when using the Auto MCACC Setup</i> on page 40). If the noise level cannot be kept low enough, you will have to set up the surround sound manually (page 84). When using only one surround back speaker, connect it to the SURROUND BACK L (Single) terminals. To use a 5.1-channel speaker set, use the surround speakers for the surround channel, not the surround back channel. Make sure there are no obstacles between the speakers and the microphone. If Reverse Phase is displayed, try the following: <ul style="list-style-type: none"> The speaker's wiring (+ and -) may be inverted. Check the speaker connections. Depending on the type of speakers and their installation conditions, Reverse Phase may be displayed even if the speakers are properly connected. If this happens, select GO NEXT and continue. If the speaker is not pointed to the microphone (listening position) or when using speakers that affect the phase (dipole speakers, reflective speakers, etc.), it may not be possible to properly identify the polarity.

Symptom	Remedy
After using the Auto MCACC Setup, the speaker size setting is incorrect.	<ul style="list-style-type: none"> There may have been some low frequency noise in the room from an air-conditioner, motor, etc. Switch off all other appliances in the room and use Auto MCACC Setup again. Depending on a number of factors (room size, speaker placement, etc.) this may occur in some cases. Change the speaker setting manually in <i>Speaker Setting</i> on page 85, and use the ALL (Keep SP System) option for the Auto MCACC menu in <i>Automatic MCACC (Expert)</i> on page 72 if this is a recurring problem.
Can't adjust the Fine Speaker Distance setting (page 75) properly.	<ul style="list-style-type: none"> Check that the speakers are all in phase (make sure the positive (+) and negative (-) terminals are matched up properly).
The display shows KEY LOCK ON when you try to make settings.	<ul style="list-style-type: none"> With the receiver in standby, press STANDBY/ON while holding down SPEAKERS to disable the key lock.
Most recent settings have been erased.	<ul style="list-style-type: none"> The power cord was disconnected from the wall while adjusting this setting. Settings are only stored if all the zones are turned off. Turn off all the zones before unplugging the power cord.
The various system settings are not stored.	<ul style="list-style-type: none"> Make sure the blue STANDBY/ON light has gone out before unplugging.

Professional Calibration EQ graphical output

Symptom	Remedy
The EQ response displayed in the graphical output following calibration does not appear entirely flat.	<ul style="list-style-type: none"> There are cases where the graph does not appear flat (even when selecting ALL CH ADJ in the Auto MCACC Setup) due to adjustments made to compensate for room characteristics to achieve optimal sound. Areas of the graph may appear identical (before and after) when there is little or no adjustment needed. The graph may appear to have shifted vertically when comparing before and after measurements.
EQ adjustments made using the <i>Manual MCACC setup</i> on page 74 do not appear to change the graphical output.	<ul style="list-style-type: none"> Despite level adjustments being made, the filters used for analysis may not display these adjustments in the graphical output. However, these adjustments are taken into account by the filters dedicated to overall system calibration.
Lower frequency response curves do not seem to have been calibrated for SMALL speakers.	<ul style="list-style-type: none"> Low frequencies used in bass management (the subwoofer channel) will not change for speakers that have been specified as SMALL in the configuration, or do not output these frequencies. Calibration is performed, but due to your speakers' low frequency limitations, no measurable sound is output for display.

Display

Symptom	Remedy
The display is dark or off.	<ul style="list-style-type: none"> Press DIMMER repeatedly to select a different brightness.
After making an adjustment the display goes off.	<ul style="list-style-type: none"> Press DIMMER repeatedly to select a different brightness.
You can't get DIGITAL to display when using SIGNAL SEL .	<ul style="list-style-type: none"> Check the digital connections and make sure that the digital inputs are assigned correctly (see <i>The Input Setup menu</i> on page 40). If the multichannel analog inputs are selected, select a different input function.
DIGITAL or DTS does not light when playing Dolby/DTS software.	<ul style="list-style-type: none"> These indicators does not light if playback is paused. Check the playback (especially the digital output) settings of the source component.
When playing Dolby Digital or DTS sources, the receiver's format indicators do not light.	<ul style="list-style-type: none"> Check that the player is connected using a digital connection. Make sure that the receiver is set to AUTO or DIGITAL (see <i>Choosing the input signal</i> on page 55). Check that the player isn't set up so that Dolby Digital and DTS sources are converted to PCM. Ensure that if there are several audio tracks on the disc, the Dolby Digital or DTS is selected.
When playing certain discs, none of the receiver's format indicators light.	<ul style="list-style-type: none"> The disc may not contain 5.1/6.1 channel material. Check the disc packaging for more on what audio tracks are recorded on the disc.
When playing a disc with the listening mode set to Auto Surround or ALC, PL II or Neo:6 appear on the receiver.	<ul style="list-style-type: none"> Make sure that the receiver is set to AUTO or DIGITAL (see <i>Choosing the input signal</i> on page 55). If a two channel soundtrack is currently playing (including Dolby Surround encoded), then this is not a malfunction. Check the disc packaging for details about the audio tracks available.

Symptom	Remedy
During playback of a Surround EX or DTS-ES source on the SBch AUTO setting, EX or ES does not appear, or the signal is not properly processed.	<ul style="list-style-type: none"> The source may be Dolby Surround EX/DTS-ES software, but it has no flag to indicate it is 6.1 compatible. Set to SBch ON (see <i>Using surround back channel processing</i> on page 53), then switch to the THX Surround EX or Standard EX listening mode (see <i>Listening in surround sound</i> on page 50).
During playback of DVD-Audio, the display shows PCM .	<ul style="list-style-type: none"> This will occur when playing DVD-Audio material over the HDMI connection. This is not a malfunction.
The power turns off automatically and some indicator flashes, or some indicator flashes and the power does not turn on.	<ul style="list-style-type: none"> See the Power section (page 92).

Remote control

Symptom	Remedy
Cannot be remote controlled.	<ul style="list-style-type: none"> Set a 5-digit preset code corresponding to the receiver to be operated in the remote control (see <i>Operating multiple receivers</i> on page 67). Check whether the receiver's remote control mode is properly set (see <i>Remote Control Mode Setup</i> on page 90). Try replacing the batteries in the remote control (see <i>Loading the batteries</i> on page 8). Be sure to operate within 7 m and a 30° angle of the remote sensor on the front panel (see <i>Operating range of remote control unit</i> on page 8). Check that there are no obstacles between the receiver and the remote control. Make sure that there is no fluorescent or other strong light shining on to the remote sensor. Check the connections of the CONTROL IN jack (see <i>Operating other Pioneer components with this unit's sensor</i> on page 33).
Other components can't be operated with the system remote.	<ul style="list-style-type: none"> If the battery ran down, the preset codes may have been cleared. Re-enter the preset codes. The preset code may be incorrect. Redo the procedure for entering preset codes.

HDMI

Symptom	Remedy
The HDMI indicator blinks continuously.	<ul style="list-style-type: none"> Check all the points below.
No picture or sound.	<ul style="list-style-type: none"> This receiver is HDCP-compatible. Check that the components you are connecting are also HDCP-compatible. If they are not, please connect them using the component, S-Video or composite video jacks. Depending on the connected source component, it's possible that it will not work with this receiver (even if it is HDCP-compatible). In this case, connect using the component, S-Video or composite video jacks between source and receiver. If the problem still persists when connecting your HDMI component directly to your monitor, please consult the component or monitor manual or contact the manufacturer for support. If video images do not appear on your TV or flat screen TV, try adjusting the resolution, DeepColor or other setting for your component. While analog video signals are being output over HDMI, use a separate connection for audio output. When this receiver reproduces MULTI CH IN audio sources with the HDMI setting set to THROUGH, you cannot hear audio output from all channels. In this case, make a digital or analog audio connection. To output signals in DeepColor, use an HDMI cable (High Speed HDMI™ Cable) to connect this receiver to a component or TV with the DeepColor feature.
No picture.	<ul style="list-style-type: none"> Try changing the Resolution setting (in <i>Setting the Video options</i> on page 61). Set the HDMI output setting to the connected HDMI OUT terminal (in <i>Switching the HDMI output</i> on page 65).

Symptom	Remedy
No sound, or sound suddenly ceases.	<ul style="list-style-type: none"> • Check that the HDMI AV setting is set to AMP/THROUGH. • If the component is a DVI device, use a separate connection for the audio. • If analog video is being output over HDMI, please use a separate connection for the audio. • Check the audio output settings of the source component.
Noisy or distorted picture.	<ul style="list-style-type: none"> • Sometimes a video deck may output a noisy video signal (during scanning, for example), or the video quality may just be poor (with some video game units, for example). The picture quality may also depend on the settings, etc. of your display device. Switch off the video converter and reconnect the source and display device using the same type of connection (component, S-Video or composite), then start playback again. • If the problem still persists when connecting your HDMI component directly to your monitor, please consult the component or monitor manual or contact the manufacturer for support.
HDCP ERROR shows in the display.	<ul style="list-style-type: none"> • Check whether or not the connected component is compatible with HDCP. If it is not compatible with HDCP, reconnect the source device using a different type of connection (component, S-Video or composite). Some components that are compatible with HDCP still cause this message to be displayed, but so long as there is no problem with displaying video, this is not a malfunction.
Amp-linked operation not possible using KURO LINK function.	<ul style="list-style-type: none"> • Check the HDMI connections. • The cable may be damaged. • Select ON for the KURO LINK setting (see <i>KURO LINK Setup</i> on page 58). • Turn the TV's power on before turning on this receiver's power. • Set the TV side KURO LINK setting to ON. • Connect the TV to the HDMI OUT 1 terminal and set the HDMI output to HDMI OUT 1. Then turn on first the TV's power, then this receiver's power.

Important information regarding the HDMI connection

There are cases where you may not be able to route HDMI signals through this receiver (this depends on the HDMI-equipped component you are connecting—check with the manufacturer for HDMI compatibility information).

If you aren't receiving HDMI signals properly through this receiver (from your component), please try one of the following configurations when connecting up.

Configuration A

Use component video cables to connect the video output of your HDMI-equipped component to the receiver's component video input. The receiver can then convert the analog component video signal to a digital HDMI signal for transmission to the display. For this configuration, use the most convenient connection (digital is recommended) for sending audio to the receiver. See the operating instructions for more on audio connections.

Note

- The picture quality will change slightly during conversion.

Configuration B

Connect your HDMI-equipped component directly to the display using an HDMI cable. Then use the most convenient connection (digital is recommended) for sending audio to the receiver. See the operating instructions for more on audio connections. Set the display volume to minimum when using this configuration.

Note

- If your display only has one HDMI terminal, you can only receive HDMI video from the connected component.
- Depending on the component, audio output may be limited to the number of channels available from the connected display unit (for example audio output is reduced to 2 channels for a monitor with stereo audio limitations).
- If you want to switch the input function, you'll have to switch functions on both the receiver and your display unit.
- Since the sound is muted on the display when using the HDMI connection, you must adjust the volume on the display every time you switch input functions.

USB interface

Symptoms	Causes	Remedies
The folders/files stored on a USB memory device are not displayed.	The folders/files are currently stored in a region other than the FAT (File Allocation Table) region.	Store the folders/files in the FAT region.
	The number of levels in a folder is more than 8.	Limit the maximum number of levels in a folder to 8 (page 45).
	There are more than 30 000 folders/files stored in a USB memory device.	Limit the maximum number of folders/files stored in a USB memory device to 30 000 (page 45).
A USB memory device is not recognized.	The audio files are copyrighted.	Copyrighted audio files stored on a USB memory device cannot be played back (page 45).
	The USB memory device does not support the mass storage class specifications.	Try using a USB memory device compatible with the mass storage class specifications. Note that there are cases where even the audio files stored on a USB memory device compatible with the mass storage class specifications are not played back on this receiver (page 45). Connect the USB memory device and switch on this receiver (page 36).
	A USB hub is currently being used.	This receiver does not support a USB hub (page 45).
A USB memory device is connected and displayed, but the audio files stored on the USB memory device cannot be played back.	This receiver recognizes the USB memory device as a fraud.	Switch off and on again this receiver.
	Some formats of a USB memory device, including FAT 12, NTFS, and HFS, cannot be played back on this receiver.	Check whether the format of your USB memory device is either FAT 16 or FAT 32. Note that the FAT 12, NTFS, and HFS formats cannot be played back on this receiver (page 45).
	The file format cannot be properly played back on this receiver.	See the list of file formats that can be played back on this receiver (page 47).

If the problem is not solved after the troubleshooting above, if the screen freezes unexpectedly or if the buttons on the remote control or front panel stop working completely, do the following:

- Press **⏻ STANDBY/ON** on the front panel to turn off the power, then turn the power back on.
- If the power cannot be turned off, press and hold **⏻ STANDBY/ON** on the front panel for over 10 seconds. The power will turn off. (In this case, the various settings made on the receiver may be cleared.)

Surround sound formats

Below is a brief description of the main surround sound formats you'll find on DVDs, satellite, cable and terrestrial broadcasts, and video cassettes.

Dolby

The Dolby technologies are explained below. See www.dolby.com for more detailed information.



Dolby Digital

Dolby Digital is a multichannel digital audio coding system widely used in cinemas, and in the home for DVD and digital broadcast soundtracks. It can deliver up to six discrete audio channels, comprising five full range channels and a special LFE (low frequency effects) channel used mainly for deep, rumbling sound effects; hence the term "5.1-channel" Dolby Digital.

In addition to the format features above, Dolby Digital decoders offer downmixing for compatibility with mono, stereo and Dolby Pro Logic audio from a number of bit rates and channels. Another feature, called Dialog Normalization, attenuates programs based on the average level of dialog in a program relative to its peak level (also known as Dialnorm) in order to achieve uniform playback level.

Dolby Digital Surround EX

Dolby Digital Surround EX (the EX stands for EXtended) is an extension of Dolby Digital encoding whereby a surround back channel is matrixed into the surround left/right channels for 6.1 channel playback. This allows for compatibility with Dolby Digital 5.1 channel decoding, as well as for decoding using Dolby Digital EX.

Dolby Pro Logic IIx and Dolby Surround

Dolby Pro Logic IIx is an improved version of the Dolby Pro Logic II (and Dolby Pro Logic) *decoding* system. Using the innovative "steering logic" circuit, this system extracts surround sound from sources as follows:

- **Dolby Pro Logic** – 4.1 channel sound (mono surround) from any stereo source
- **Dolby Pro Logic II** – 5.1 channel sound (stereo surround) from any stereo source
- **Dolby Pro Logic IIx** – 6.1 or 7.1 channel sound (stereo surround and surround back) from two channel or 5.1 (and 6.1) channel sources

With two channel sources, the ".1" subwoofer channel is generated by bass management in the receiver.

Dolby Surround is an *encoding* system which embeds surround sound information within a stereo soundtrack, which a Dolby Pro Logic decoder can then use for enhanced surround listening with greater sound detail.

Dolby Digital Plus

Dolby Digital Plus is the next-generation audio technology for all high-definition programming and media. It combines the efficiency to meet future broadcast demands with the power and flexibility to realize the full audio potential expected in the upcoming high-definition era. Built on Dolby Digital, the multi-channel audio standard for DVD and HD broadcasts worldwide, Dolby Digital Plus was designed for the next-generation A/V receivers but remains fully compatible with all current A/V receivers.

Dolby Digital Plus delivers multi-channel audio programs of up to 7.1 channels (*) and supports multiple programs in a single encoded bitstream with the maximum bit rate potential of up to 6 Mbps and the maximum bit rate performance of up to 3 Mbps on HD DVD and 1.7 Mbps on Blu-ray Disc, and it outputs Dolby Digital bitstreams for playback on existing Dolby Digital systems. Dolby Digital Plus can accurately reproduce the sound originally intended by directors and producers.

It also features multi-channel sound with discrete channel output, interactive mixing and streaming capability in advanced systems. Supported by High-Definition Media Interface (HDMI), a single-cable digital connection is possible for high-definition audio and video.

Dolby TrueHD

Dolby TrueHD is the next-generation lossless encoding technology developed for high-definition optical discs in the upcoming era. Dolby TrueHD delivers tantalizing sound that is bit-for-bit identical to the studio master, unlocking the true high-definition entertainment experience on high-definition optical discs in the next generation. When coupled with high-definition video, Dolby TrueHD offers an unprecedented home theater experience with stunning sound and high-definition picture.

It supports bit rates of up to 18 Mbps and records up to 8 full-range channels (*) individually with 24-bit/96 kHz audio. It also features extensive metadata including dialogue normalization and dynamic range control. Supported by High-Definition Media Interface (HDMI), a single-cable digital connection is possible for high-definition audio and video.

HD DVD and Blu-ray Disc standards currently limit their maximum number of audio channels to eight, whereas Dolby Digital Plus and Dolby TrueHD support more than eight audio channels.

Manufactured under license from Dolby Laboratories. Dolby, Pro Logic, Surround EX and the double-D symbol are trademarks of Dolby Laboratories.

DTS

The DTS technologies are explained below. See www.dtstech.com for more detailed information.

**DTS Digital Surround**

DTS Digital Surround is a 5.1-channel audio coding system from DTS Inc. now widely used for DVD-Video, DVD-Audio, 5.1 music discs, digital broadcasts, and video games. It can deliver up to six discrete audio channels, comprising five full range channels, including an LFE channel. Higher sound quality is achieved through the use of a low compression rate, and high rates of transmittance during playback.

DTS-ES

DTS-ES (the ES stands for Extended Surround) is a decoder that is capable of decoding both DTS-ES Discrete 6.1 and DTS-ES Matrix 6.1 encoded sources. DTS-ES Discrete 6.1 gives 'true' 6.1 channel sound, with a completely separate (discrete) surround back channel. DTS-ES Matrix 6.1 has a surround back channel matrixed into the surround left/right channels. Both sources are also compatible with a conventional DTS 5.1 channel decoder.

DTS Neo:6

DTS Neo:6 can generate 7.1 channel surround sound from any matrixed stereo source (such as video or TV) and from 5.1 channel sources. It uses both the channel information already encoded into the source, as well as its own processing to determine channel localization (with two channel sources, the ".1" subwoofer channel is generated by bass management in the receiver). Two modes (Cinema and Music) are available using DTS Neo:6 with two channel sources.

DTS 96/24

DTS 96/24 is an extension of the original DTS Digital Surround which offers high quality 96 kHz/24-bit audio using a DTS 96/24 decoder. This format is also fully backward compatible with all existing decoders. This means that DVD players can play this software using a conventional DTS 5.1 channel decoder.

DTS-EXPRESS

DTS-EXPRESS is a low-bitrate encoding technology supporting up to 5.1 channels with fixed data transfer rates. This format is incorporated with sub audio on HD DVD and secondary audio on Blu-ray Disc while boasting the potential applicability to upcoming broadcasts and memory audio contents.

DTS-HD Master Audio

DTS-HD Master Audio is a technology that delivers master audio sources recorded in a professional studio to listeners without any loss of data, preserving audio quality. DTS-HD Master Audio adopts variable data transfer rates, facilitating data transfer to the maximum rate of 24.5 Mbps in the Blu-ray disc format, 18.0 Mbps in the HD-DVD format, which by far exceeds that of a standard DVD. These high data transfer rates enable lossless transmission of 96 kHz/24-bit 7.1-channel audio sources without deteriorating the quality of the original sound. DTS-HD Master Audio is an irreplaceable technology that can reproduce sound faithfully as intended by the creator of music or movies.

Manufactured under license under U.S. Patent #'s: 5,451,942; 5,956,674; 5,974,380; 5,978,762; 6,226,616; 6,487,535; 7,212,872; 7,333,929; 7,392,195; 7,272,567 & other U.S. and worldwide patents issued & pending. DTS is a registered trademark and the DTS logos, Symbol, DTS-HD and DTS-HD Master Audio are trademarks of DTS, Inc. © 1996-2008 DTS, Inc. All Rights Reserved.

Windows Media Audio 9 Professional

Windows Media Audio 9 Professional (WMA9 Pro) is a discrete surround format developed by Microsoft Corporation.



Windows Media and the Windows logo are trademarks or registered trademarks of Microsoft Corporation in the United States and/or other countries.

About iPod

"Made for iPod" means that an electronic accessory has been designed to connect specifically to iPod and has been certified by the developer to meet Apple performance standards.

"Works with iPhone" means that an electronic accessory has been designed to connect specifically to iPhone and has been certified by the developer to meet Apple performance standards.

Apple is not responsible for the operation of this device or its compliance with safety and regulatory standards.

iPod is a trademark of Apple Inc., registered in the U.S. and other countries. iPhone is a trademark of Apple Inc.

About THX

The THX technologies are explained below. See www.thx.com for more detailed information.



• THX Cinema processing

THX is an exclusive set of standards and technologies established by THX Ltd. THX grew from George Lucas' personal desire to make your experience of the film soundtrack, in both movie theatres and in your home theatre, as faithful as possible to what the director intended. Movie soundtracks are mixed in special movie theatres called dubbing stages and are designed to be played back in movie theatres with similar equipment and conditions. This same soundtrack is then transferred directly onto Laserdisc, VHS tape, DVD, etc., and is not changed for playback in a small home theatre environment. THX engineers developed patented technologies to accurately translate the sound from the movie theatre environment into the home, correcting the tonal and spatial errors that occur. On this product, when the THX indicator is on, THX features are automatically added in Cinema modes (e.g. THX Cinema, THX Surround EX).

• Re-Equalization

The tonal balance of a film soundtrack will be excessively bright and harsh when played back over audio equipment in the home because film soundtracks were designed to be played back in large movie theaters using very different professional equipment. Re-Equalization restores the correct tonal balance for watching a movie soundtrack in a small home environment.

• Timbre Matching

The human ear changes our perception of a sound depending on the direction from which the sound is coming. In a movie theatre, there is an array of surround speakers so that the surround information is all around you. In a home theatre, you use only two speakers located to the side of your head. The Timbre Matching feature filters the information going to the surround speakers so that they more closely match the tonal characteristics of the sound coming from the front speakers. This ensures seamless panning between the front and surround speakers.

• Adaptive Decorrelation

In a movie theatre, a large number of surround speakers help create an enveloping surround sound experience, but in a home theatre there are usually only two speakers. This can make the surround speakers sound like headphones that lack spaciousness and envelopment. The surround sounds will also collapse into the closest speaker as you move away from the middle seating position. Adaptive Decorrelation slightly changes one surround channel's time and phase relationship with respect to the other surround channel. This expands the listening position and creates—with only two speakers—the same spacious surround experience as in a movie theatre.

• THX Select2 Plus

Before any home theatre component can be THX Select2 Plus certified, it must incorporate all the features above and also pass a rigorous series of quality and performance tests. Only then can a product feature the THX Select2 Plus logo, which is your guarantee that the Home Theatre products you purchase will give you superb performance for many years to come. THX Select2 Plus requirements cover every aspect of the product including pre-amplifier and power amplifier performance and operation, and hundreds of other parameters in both the digital and analog domain.

• THX Surround EX

THX Surround EX - Dolby Digital Surround EX is a joint development of Dolby Laboratories and the THX Ltd. In a movie theater, film soundtracks that have been encoded with Dolby Digital Surround EX technology are able to reproduce an extra channel which has been added during the mixing of the program. This channel, called Surround Back, places sounds behind the listener in addition to the currently available front left, front center, front right, surround right, surround left and subwoofer channels. This additional channel provides the opportunity for more detailed imaging behind the listener and brings more depth, spacious ambience and sound localization than ever before. Movies that were created using the Dolby Digital Surround EX technology, when released into the home consumer market may exhibit wording to that effect on the packaging. A list of movies created using this technology can be found on the Dolby web site at www.dolby.com.

Only amplifier and controller products bearing the THX Surround EX logo, when in the THX Surround EX mode, faithfully reproduce this new technology in the home.

This product may also engage the "THX Surround EX" mode during the playback of 5.1 channel material that is not Dolby Digital Surround EX encoded. In such case the information delivered to the Surround Back channel will be program dependent and may or may not be very pleasing depending on the particular soundtrack and the tastes of the individual listener.

• Advanced Speaker Array (ASA)

ASA is a proprietary THX technology which processes the sound fed to 2 side and 2 back surround speakers to provide the optimal surround sound experience. When you set up your home theater system using all eight speaker outputs (Left, Center, Right, Surround Right, Surround Back Right, Surround Back Left, Surround Left and Subwoofer) placing the two Surround Back speakers close together facing the front of the room as shown in the diagram will provide the largest sweet spot. If for practical reasons you have to place the Surround Back speakers apart, you will need to go THX Audio Set-up screen and choose the setting that most closely corresponds to the speaker spacing, which will re-optimize the surround sound-field. ASA is used in three new modes: THX Select2 CINEMA, THX Select2 MUSIC and THX Select2 GAMES.

• Boundary Gain Compensation™

Depending on the listener's and the subwoofer's position, the listener may experience an excessive bass effect. This feature compensates for excessive bass resulting from a boundary gain effect. This feature is designed to operate when used with a subwoofer certified to THX Select2™ specifications.

• THX Music

For the replay of multi-channel music the THX MusicMode should be selected. In this mode THX ASA processing is applied to the surround channels of all 5.1 encoded music sources such as DTS, Dolby Digital and DVD-Audio to provide a wide stable rear soundstage.

• THX Games

For the replay of stereo and multi-channel game audio the THX Games Mode should be selected. In this mode THX ASA processing is applied to the surround channels of all 5.1 and 2.0 encoded game sources such as analog, PCM, DTS and Dolby Digital. This accurately places all game audio surround information, providing a full 360 degree playback environment. THX Games Mode is unique as it gives you a smooth transition of audio in all points of the surround field.

• THX Loudness Plus Description

THX Loudness Plus is a new volume control technology featured in THX Ultra2 Plus™ and THX Select2 Plus™ Certified amplifiers. With THX Loudness Plus, home theater audiences can now experience the rich details in a surround mix at any volume level. A consequence of turning the volume below Reference Level is that certain sound elements can be lost or perceived differently by the listener. THX Loudness Plus compensates for the tonal and spatial shifts that occur when the volume is reduced by intelligently adjusting ambient surround channel levels and frequency response. This enables users to experience the true impact of soundtracks regardless of the volume setting. THX Loudness Plus is automatically applied when listening in any THX listening mode. The new THX Cinema, THX Music, and THX Games modes are tailored to apply the proper THX Loudness Plus settings for each type of content.

• ASA Description

ASA is a proprietary THX technology which processes the sound fed to 2 side and 2 back surround speakers to provide the optimal surround sound experience. When you set up your home theater system using all eight speaker outputs (Left, Center, Right, Surround Right, Surround Back Right, Surround Back Left, Surround Left and Subwoofer), be sure to go to the THX Audio Set-up screen and choose the setting that most closely corresponds to the speaker spacing, which will re-optimize the surround sound-field. ASA is used in three modes: THX Ultra2 Cinema, THX Ultra2 Music and THX Ultra2 Games.

• THX Select2 Cinema

THX Select2 Cinema mode plays 5.1 movies using all 8 speakers giving you the best possible movie watching experience. In this mode, ASA processing blends the side surround speakers and back surround speakers providing the optimal mix of ambient and directional surround sounds. DTS-ES (Matrix and 6.1 Discrete) and Dolby Digital Surround EX encoded soundtracks will be automatically detected in Select2 Cinema mode if the appropriate flag has been encoded.

Some Dolby Digital Surround EX soundtracks are missing the digital flag that allows automatic switching. If you know that the movie that you are watching is encoded in Surround EX, you can manually select the THX Surround EX playback mode, otherwise THX Select2 Cinema mode will apply ASA processing to provide optimum replay.

• THX Select2 Music

For the playback of multi-channel music the THX Select2 Music mode should be selected. In this mode THX ASA processing is applied to the surround channels of all 5.1 encoded music sources such as DTS, Dolby Digital and DVD-Audio to provide a wide stable rear soundstage.

• THX Select2 Games

For the playback of stereo and multi-channel game audio the THX Select2 Games mode should be selected. In this mode THX ASA processing is applied to the surround channels of all 5.1 and 2.0 encoded game sources such as analog, PCM, DTS and Dolby Digital. This accurately places all game audio surround information, providing a full 360 degree playback environment. THX Select2 Games mode is unique as it gives you a smooth transition of audio in all points of the surround field.

THX, the THX logo and Select2 Plus are trademarks of THX Ltd. which may be registered in some jurisdictions. All rights reserved. All other trademarks are the property of their respective owners.

About Neural – THX Surround



Neural-THX® Surround is taking surround sound to the next level. This revolutionary new technology delivers the rich envelopment and discrete image detail of surround sound in a format that is fully compatible with stereo from various content sources. Neural-THX Surround enables 5.1, 6.1 and 7.1-channel support for gaming, movies and digital music. By unmasking the audio details, typically lost by other playback modes, audiences will experience the deep ambience and subtle details of movies, music and games.

Neural-THX® Digital Music™ is a new surround mode specifically designed to enhance the playback of compressed digital music content. It provides listeners with an expanded sound stage and clean surround experience, even with compressed audio sources such as MP3s and Internet streams.

Neural-THX Surround has been chosen as the official surround sound format for TV sports broadcasting, 7.1 games, Music Direct Internet streaming as well as leading FM/HD radio stations worldwide. And with this technology being used by sound designers during content creation, as well as embedded into playback devices, Neural-THX Surround promises a listening experience that is true to the original mix.

For additional information, please visit www.neuralsurround.com. This product is manufactured under license from Neural Audio Corporation and THX Ltd. PIONEER Corporation hereby grants the user a non-exclusive, non-transferable, limited right of use to this product under USA and foreign patent, patent pending and other technology or trademarks owned by Neural Audio Corporation and THX Ltd. "Neural Surround", "Neural Audio", "Neural" and "NRL" are trademarks and logos owned by Neural Audio Corporation, THX is a trademark of THX Ltd., which may be registered in some jurisdictions. All rights reserved.

Auto Surround, ALC and Stream Direct with different input signal formats

The following charts show what you will hear with different input signal formats, depending on the Stream Direct mode (see *Using Stream Direct* on page 53) you have selected.

Stereo (2 channel) signal formats

Input signal format	Auto Surround / ALC / DIRECT	PURE DIRECT
Surround Back speaker(s): Connected		
Dolby Digital Surround	□□ Pro Logic IIx MOVIE	□□ Pro Logic IIx MOVIE
DTS Surround	Neo:6 CINEMA	Neo:6 CINEMA
Other stereo sources	Stereo playback	Stereo playback
Analog sources	As above	ANALOG DIRECT (stereo)
PCM sources	As above	Stereo playback
DVD-A sources	As above	As above
SACD sources	As above	As above
Surround Back speaker(s): Not connected		
Dolby Digital Surround	□□ Pro Logic II MOVIE	□□ Pro Logic II MOVIE
DTS Surround	Neo:6 CINEMA	Neo:6 CINEMA
Other stereo sources	Stereo playback	Stereo playback
Analog sources	As above	ANALOG DIRECT (stereo)
PCM sources	As above	Stereo playback
DVD-A sources	As above	As above
SACD sources	As above	As above

Multichannel signal formats

Input signal format	Auto Surround / ALC	PURE DIRECT / DIRECT
Surround Back speaker(s): Connected		
Dolby Digital EX (6.1 channel flagged)	Dolby Digital EX □□ Pro Logic IIx MOVIE ^a	Dolby Digital EX □□ Pro Logic IIx MOVIE ^a
DTS-ES (6.1 channel sources/6.1 channel flagged)	DTS-ES (Matrix/Discrete)	DTS-ES (Matrix/Discrete)
DTS sources (5.1 channel encoding)	DTS+Neo:6	Straight decoding
DTS-HD sources	Straight decoding	As above
Other 6.1/7.1 channel sources	As above	As above
Other 5.1 channel sources	Dolby Digital EX □□ Pro Logic IIx MOVIE ^a	As above
Surround Back speaker(s): Not connected		
DVD-A sources/Multi-ch PCM	Straight decoding	Straight decoding
SACD sources (5.1 channel encoding)	As above	As above
Other 5.1/6.1/7.1 channel sources	As above	As above

a.Unavailable with only one surround back speaker connected.

Preset code list

You should have no problem controlling a component if you find the manufacturer in this list, but please note that there are cases where codes for the manufacturer in the list will not work for the model that you are using. There are also cases where only certain functions may be controllable after assigning the proper preset code.

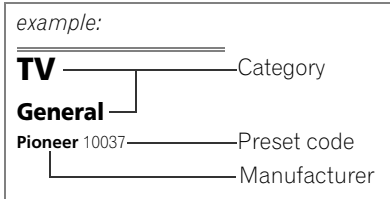

TV

General

- Pioneer** 10037, 10166, 10679, 11247, 11260, 11398
- A.R. Systems** 10556, 10037
- Accent** 10037
- Acer** 11403
- Acoustic Solutions** 11523
- ADL** 11217
- Admiral** 10093
- Aiko** 10037, 10092
- Aim** 10037
- Akai** 10556, 10037, 10000, 10702, 11675
- Akiba** 10037
- Akito** 10037
- Akura** 10037, 10171, 11498, 11687
- Alba** 10037, 10587
- All-Tel** 10865
- Allstar** 10037
- Amstrad** 10037, 10000, 10171
- Amtron** 10000, 10180
- Anam** 10037, 10180, 10250
- Anam National** 10037, 10650, 10250
- Anitech** 10037
- Ansonic** 10037
- AOC** 10625, 11365
- Ardem** 10037
- Arena** 10037
- Aristona** 10556, 10037
- Asberg** 10037
- Atlantic** 10037
- Audioasonic** 10037, 10865
- Audiovox** 10092, 10180, 10451, 10623
- Aumark** 10060
- AVP** 10000
- Awa** 10451
- Baird** 10037
- Basic Line** 10556, 10037
- Baur** 10037
- Baysonic** 10180
- Beaumark** 10178
- Beko** 10037
- Bell & Howell** 10017, 10154
- BenQ** 11574
- Beon** 10037
- Bestar** 10037
- Blue Sky** 10556, 10037, 11314
- BPL** 10037
- Bradford** 10180
- Brandt** 10625
- Brinkmann** 10037
- Brionvega** 10037
- Broksonic** 10463
- Bush** 10556, 10037, 10587, 10661, 11645, 11687, 12053
- Byd:sign** 11309
- Carena** 10037
- Carrefour** 10037
- Carver** 10054
- Cascade** 10037
- Casio** 10037
- Cathay** 10037
- CCE** 10037
- Celebrity** 10000
- Centurion** 10037
- Cineral** 10092, 10451
- Citizen** 10060, 10092, 10180
- Clarion** 10180
- Clarivox** 10037
- Clatronic** 10037
- Condor** 10037
- Conia** 11498, 11687
- Contec** 10037, 10180
- Cosmel** 10037
- Craig** 10180
- Crosley** 10054, 10180
- Crown** 10037, 10053, 10180, 10672
- Crown Mustang** 10672
- CTX** 11756
- Curtis Mathes** 10047, 10051, 10054, 10060, 10093, 10145, 10154, 10166, 10451
- CXC** 10180
- D-Vision** 10556, 10037
- Daewoo** 10556, 10037, 10092, 10154, 10178, 10451, 10623, 10661, 10865, 11812
- Dansai** 10037
- Dawa** 10037
- Daytron** 10037, 10092, 10178
- Decca** 10037
- Dell** 11264, 11403
- Denon** 10145
- Denver** 10037, 10587
- Desmet** 10037
- Diamant** 10037
- Digatron** 10037
- Digiline** 10037
- Digimate** 10890
- Dixi** 10037
- DMTech** 12001
- Dream Vision** 11704
- Dual** 10037
- Dumont** 10017
- Dux** 10037
- Dynatron** 10037
- Dynex** 11463
- ECE** 10037
- Elbe** 10556, 10037
- Electroband** 10000
- Electrohome** 10463
- Element** 11687
- ELG** 10037
- Elin** 10037
- Elite** 10037
- Emerson** 10037, 10017, 10047, 10154, 10178, 10180, 10236, 10463, 10623
- Envison** 11365
- Erres** 10037
- ESC** 10037
- Euroman** 10037
- Europa** 10037
- Europhon** 10037
- Evesham** 11719
- Evolution** 11756
- Exquisit** 10037
- Ferguson** 10037, 10625, 10053, 12053
- Fidelity** 10037, 10171
- Finlux** 10556, 10037
- Firstline** 10556, 10037
- Fisher** 10000, 10047, 10054, 10154
- Flint** 10037
- Formenti** 10037
- Fortress** 10093
- Fraba** 10037
- Friac** 10037
- Fujimaro** 10865
- Fujitsu** 10683, 10809, 10853
- Fujitsu General** 10683
- Funai** 10171, 10180, 11394, 11817
- Futuretech** 10180
- Galaxi** 10037
- Galaxis** 10037
- Gateway** 11755
- GE** 10047, 10051, 10093, 10178, 10451, 11147
- GEC** 10037
- Genexxa** 10037
- Gericom** 10865, 11217
- Gibralter** 10017
- Go Video** 10060
- GoldStar** 10037, 10178
- Goodmans** 10556, 10037, 10625, 10000, 10661, 11645, 11687, 11719, 12053
- Gradiente** 10037, 10053
- Granada** 10037, 10226
- Grandin** 10556, 10037, 10865
- Grundig** 10556, 10037, 10587, 10672, 12053, 12127
- Grunpy** 10180
- H & B** 12001
- Haier** 11748
- Hallmark** 10178
- Hannspree** 11351, 12027
- Hanseatic** 10556, 10037, 10625, 10661
- Hantarex** 10037, 10865
- Hantor** 10037
- Harman/Kardon** 10054
- Harsper** 10865
- Harvard** 10180
- Harwood** 10037
- Hauppauge** 10037
- Havermy** 10093
- HCM** 10037
- Hightline** 10037
- Hinari** 10037
- Hisense** 10556, 11314, 12098
- Hitachi** 10037, 10000, 10047, 10051, 10054, 10145, 10150, 10178, 11484, 11576, 11691
- Hitachi Fujian** 10150
- Hoeher** 10865
- Hornlyphon** 10037
- HP** 11502
- Hugoson** 10890, 11217
- Humax** 12057
- Hypson** 10556, 10037
- Hyundai** 10865
- Iberia** 10037
- ICE** 10037
- Iiyama** 10890, 11217
- Imperial** 10037
- Indiana** 10037
- Innowert** 10865
- Inteq** 10017
- Interbuy** 10037
- Interfunk** 10037
- Internal** 10556
- Intervision** 10037
- Irradio** 10037
- Isukai** 10037
- ITS** 10037
- ITV** 10037
- JCB** 10000
- JMB** 10556
- Jubilee** 10556
- JVC** 10650, 10053, 10054, 10093, 10160, 10463, 10683, 10731, 11253, 11428, 12118
- Kaisui** 10037
- Kathrein** 10556
- KEC** 10060, 10180
- Kendo** 10037
- Kiton** 10037
- Kneissel** 10556, 10037
- Kolin** 11240, 11331, 11610
- Kolster** 10037
- Konig** 10037
- Konka** 10037
- Korpel** 10037
- Kosmos** 10037
- KTV** 10180
- L&S Electronic** 10865
- Lescon** 10037
- Lenco** 10037, 10587
- Leyco** 10037
- LG** 10556, 10037, 10017, 10178, 10856, 11178, 11423, 11663, 11768
- Liesenk & Tter** 10037
- Liesenkotter** 10037
- Lifetec** 10037, 10683
- Loewe** 10037, 10633, 11884
- Logik** 11217, 11687
- Lumatron** 10037
- Lux May** 10037
- LXI** 10047, 10054, 10154, 10156
- M Electronic** 10037, 10661
- Madison** 10037
- MAG** 11498, 11687
- Magnadyne** 10054
- Magnavox** 10054, 11454, 11866

- Magnum** 10037
Manesth 10037
Manhattan 10037
Marantz 10556, 10037, 10054, 10704, 11398
Mark 10037
Matsui 10556, 10037
Maxent 11755
Mediator 10556, 10037
Medion 10556, 10037, 12001
Megatron 10145, 10178
Memorex 10037, 10060, 10150, 10154, 10178, 10180, 10250, 10463
Mercury 10037
Metronic 10625
Metz 10037, 10587
MGA 10150, 10178
Micromaxx 10037, 12001
Midland 10017, 10047, 10051
Minato 10037
Minoka 10037
Mirai 11852, 12072
Mitsubishi 10556, 10037, 10093, 10150, 10160, 10178
Morgan's 10037
Motorola 10093
MTC 10060, 10092
Multitec 10037
Multitech 10037, 10180
Mx Onda 11498, 11687
Myriad 10556
NAD 10037, 10865
Naiko 10037
Nakimura 10037
NAT 10226
National 10226
NEC 10053, 10704, 11704, 11797
Neckermann 10556, 10037
NEI 10037
Neovia 10865, 11710
Netsat 10037
Neufunk 10556, 10037
New Tech 10556, 10037
Nikkai 10037
Nikko 10178
Norcent 11365
Nordmende 10037, 12129
Normerel 10037
Novatron 10037
NTC 10092
Okano 10037
Olevia 11144, 11240, 11331, 11610
Onida 10053, 11253
Onwa 10180
Opera 10037
Optimus 10650, 10166, 10250
Orbit 10037
Orion 10556, 10037, 10236, 10463, 12001
Orline 10037
Osaki 10556, 10037
Osio 10037
Osume 10037
Otic 11498, 11687
Otto Versand 10556, 10037, 10226, 10093
Pacific 10556
Packard Bell 11314
Palladium 10556, 10037
Palsonic 10037
Panama 10037
Panasonic 11480, 10037, 10650, 10226, 10051, 10054, 10156, 10236, 10250, 10853, 11271, 11310, 11636, 11650
Panavision 10037
Penney 10047, 10051, 10060, 10156, 10178
Perdio 10037
Perfekt 10037
Petters 10037
Philco 10037, 10054, 10145, 11661
Philips 10556, 10037, 10000, 10017, 10054, 10605, 10690, 11254, 11454, 11506, 11756
Phoenix 10037
Phonola 10556, 10037
Plantron 10037
Playsonic 10037
Polaroid 11498, 11523, 11645, 11687, 11766
Portland 10092
Powerpoint 10037
Prism 10051
Profitronic 10037
Proline 10037, 10625
Proscan 10047
Proscro 10156
Prosonic 10037
Protec 10037
Protech 10037
Proton 10178
ProVision 10556, 10037
Pulsar 10017
Pvision 12001
Pye 10556, 10037
Quadral 10051
Quasar 10051, 10250, 10865
Quelle 10037
R-Line 10037
Radiola 10556, 10037
Radiomarelli 10037
RadioShack 10037, 10047, 10154, 10178, 10180
Radiotone 10037
RCA 10625, 10047, 10051, 10090, 10093, 11147, 11247, 11781
Realistic 10154, 10180
Recor 10037
Rectiligne 10037
Redstar 10037
Reflex 10037
Relisys 10865, 11211, 11645
Remotec 10037, 10093, 10145, 10171, 10250
Revox 10037
RFT 10037
Roadstar 10037
Runco 10017
Saba 10625
Saivod 10037
Sampo 11755
Samsung 10556, 10037, 10587, 10060, 10090, 10178, 10702, 10766, 10812, 10814, 11060, 11235, 11619, 12051
Sansui 10037, 10463
Sanyo 10037, 10000, 10047, 10154, 10704
Sanyong 10037
SBR 10556, 10037
Schneider 10556, 10037
Scotch 10178
Sears 10047, 10054, 10154, 10156, 10171, 10178
SEG 10037
SEI 10037
Sei-Sinudyne 10037
Semivox 10180
Semp 10156
Serino 10093
Sharp 10053, 10093, 10818, 11093, 11393
Shintoshii 10037
Shivaki 10037
Siemens 10037, 10145
Siera 10556, 10037
Silva 10037
Silva Schneider 10037
Silvano 10587
Singer 10037
Sinudyne 10037
SKY 10037
Sliding 10865
Somtron 10865
Solar Drape 10000
Solavox 10037
Soniko 10037
Sonneclair 10037
Sonoko 10037
Sontec 10037
Sony 10810, 10037, 10000, 10053, 10150, 10154, 11651, 11685
Soundesign 10178, 10180
Soundwave 10037
Squareview 10171
SSS 10180
Standard 10037
Starlite 10037, 10180
Strato 10037
Sunkai 10865
Sunstar 10037
Sunstech 12001
Sunwood 10037
SuperTech 10556, 10037
Supreme 10000
SVA 10587, 10865
Swisstec 10865
Sylvania 10054, 10171, 11394, 11864
Symphonic 10171, 10180
Syntax 11144, 11240, 11331
Sysline 10037
Tandy 10093
Tatung 10037, 11719, 11756
TCM 12001
Teac 10037, 10171, 10178
Tec 10037
Tech Line 10037
Technics 10556, 10650, 10051, 10250
TechniSat 10556
Technosonic 10556, 10625
Techwood 10051
Technimag 10556
Teknika 10054, 10060, 10092, 10180
Telecor 10037
Telefunken 10037, 10625, 10702
Telefusion 10037
Telegazi 10037
Telemeister 10037
Telesonic 10037
Telestar 10556, 10037
Teletech 10037
Televue 10037
Tennessee 10037
Tensai 10037
Tevion 10556, 10037, 11498, 11645, 11687
Thomson 10037, 10625, 11447
Thorn 10037
TKM 10178
Tokai 10037
Toshiba 10650, 10060, 10154, 10156, 11156, 11256, 11524, 11656
TRANS-continents 10556, 10037, 10865
Tranonic 10037, 10587
Trio 11498, 11687
Triumph 10556, 10037
TVTEXT 95 10556
Uher 10037
Ultravox 10037
Unic Line 10037
United 10037, 10587
Universal 10037
Universum 10037
Univox 10037
V2max 10865
V7 Videoseven 11217, 11755
Vestel 10037
Vexa 10037
Victor 10053, 10160, 10250, 11428
VideoSystem 10037
Vidikron 10054, 11398, 11633
Vidtech 10178
Viewsonic 11755
Vision 10037
Vizio 11758
Vortec 10037
Voxson 10037
Waltham 10037
Wards 10000, 10017, 10047, 10051, 10054, 10060, 10154, 10156, 10166, 10178, 10180, 11147
Watson 10037
Wega 10037
Westinghouse 10885, 10889, 10890
Wharfedale 10556, 10037
White Westinghouse 10037, 10623
Wilson 10556
Windy Sam 10556
World-of-Vision 10865, 10890, 11217
Xenius 10661
Xoro 11217
Xrypton 10037
Yamaha 11576
Yamishi 10037
Yapshe 10250
Yokan 10037
Yoko 10037
Zenith 10017, 10463
Plasma television
Pioneer 10166, 10679, 11247, 11260, 11398, 11633, 14002, 14003, 14004
Akai 11675
All-Tel 10865
CTX 11756
Daewoo 10661, 10865
Dell 11264
Dream Vision 11704
Evolution 11756
Fujimaro 10865
Fujitsu 10683, 10809, 10853
Fujitsu General 10683
Gateway 11755
Gericom 10865
Grandin 10865
Hantarex 10865
Harsper 10865
Hitachi 11484, 11576
Hoehner 10865
Hyundai 10865
Innowert 10865
JVC 10053, 10731
L&S Electronic 10865
LG 10037, 10178, 11423, 11663
Magnavox 11866
Marantz 11398
Maxent 11755
NEC 10704, 11704
Neovia 10865
Panasonic 11480, 10650, 10250, 10853, 11636, 11650
Philips 10556, 10605, 10690, 11756
Quasar 10865
Relisys 10865
Sampo 11755
Samsung 10812, 11619
Sanyo 10704
Sliding 10865
Somtron 10865
Sony 11651
Sunkai 10865
SVA 10865
Sylvania 11394
Tatung 11756
Tevion 11645
Thomson 10625
Toshiba 10650
Universal 10037
V2max 10865
V7 Videoseven 11755
Viewsonic 11755
Xenius 10661
Yamaha 11576
Zenith 10017
LCD
Acoustic Solutions 11523
ADL 11217
Akai 11675
AOC 10625
BenQ 11574
Blue Sky 11314
Bush 11645, 11687

Byd:sign 11309
Daewoo 10661
Dell 11264
Digatron 10037
Digimate 10890
Element 11687
Envision 11365
Evesham 11719
Funai 11394, 11817
Gericom 10865, 11217
Goodmans 11645, 11687, 11719
Grandin 10865
Grundig 12127
Haier 11748
Hannspree 11351, 12027
Hisense 11314, 12098
Hitachi 11484, 11576
Hoeher 10865
Hugoson 10890, 11217
Humax 12057
Iiyama 10890, 11217
JVC 10053, 11428, 12118
Kolin 11240, 11331, 11610
LG 10037, 10178, 11423, 11663, 11768
Loewe 11884
Logik 11217
Magnavox 11866
Medion 12001
Micromaxx 12001
Mirai 11852, 12072
NAD 10865
NEC 11797
Neovia 10865, 11710
Norcent 11365

Nordmende 12129
Olevia 11144, 11240, 11331, 11610
Orion 12001
Packard Bell 11314
Panasonic 11480, 10650, 11636, 11650
Philips 10556, 10605, 11506
Polaroid 11498, 11523, 11645, 11687, 11766
Relisys 11211, 11645
Samsung 10766, 10812, 10814, 11235, 11619, 12051
Sharp 10818, 11093, 11393
Sliding 10865
Sony 10810, 11651, 11685
Sunkai 10865
SVA 10587, 10865
Swisstec 10865
Sylvania 11864
Syntax 11144, 11240, 11331
Tatung 11719
TCM 12001
Technosonic 10625
Thomson 10625
Toshiba 11524
TRANS-continents 10865
V7 Videoseven 11217
Victor 11428
Vidikron 11398
Vizio 11758
Westinghouse 10885, 10889, 10890
World-of-Vision 10865, 10890, 11217
Xoro 11217

HDTV
Pioneer 10679
Rear Projection TV
Panasonic 11271
Philips 10037
Pye 10037
Sony 11651
Thomson 10625
Toshiba 11524, 11656
TV/DVD Combination
Akai 11675
Alba 10587
Bush 10587
Daewoo 11812
Denver 10587
DMTech 12001
Goodmans 11687
Grundig 12127
H & B 12001
Lenco 10587
Logik 11687
Philips 10556, 11454
Polaroid 11523, 11766
Pvision 12001
Sunstech 12001
Sylvania 11864
Thomson 10625
United 10587
TV/PVR Combination
Hitachi 11691

Loewe 11884
TV/VCR Combination
Amstrad 10171
Broksonic 10463
Curtis Mathes 10051
Emerson 10463
Ferguson 10625
Fidelity 10171
GE 10047, 10051, 10093
GoldStar 10037
Grundig 10556, 10037
LG 10178
Magnavox 10054
Memorex 10250
Mitsubishi 10556, 10093
Orion 10463
Panasonic 10051, 10250
Penney 10051
Philips 10556, 10037
Quasar 10051, 10250
Radiola 10556
RCA 10047, 10051, 10093
Saba 10625
Sansui 10463
Schneider 10556, 10037
Sharp 10093
Siemens 10037
Sony 10000
Sylvania 10054
Teac 10171
Technics 10556
Thomson 10625

DVR/VCR

General

Pioneer 20081, 20067, 20042, 20058, 20162, 22306, 22465, 22466, 22467
A-Mark 20278
Adventura 20000
AEG 21593
Aiko 20278
Aiwa 20037, 20348, 20000, 20032
Akai 20348
Alba 20081, 20278, 20348, 20000
Allstar 20081
America Action 20278
American High 20035
Amstrad 20278, 20000
Anam 20278, 20037, 20226, 20162
Anam National 20226, 20162, 21162
Ansonic 20000
Aristona 20081
ASA 20081, 20037
Astra 20035
Asuka 20081, 20037, 20000, 20038
Audiolab 20081
Audiosonic 20278
Audiovox 20037
AVP 20000
Awa 20037, 20320, 20043
Baird 20278, 20000
Basic Line 20278
Bestar 20278
Black Diamond 20642
Black Panther 20278
Blaupunkt 20081, 20226, 20162
Blue Sky 20278, 20037, 20348, 20642
Brandt 20320
Brinkmann 20348
Bush 20081, 20278, 20348, 20000, 20642
Calix 20037
Canon 20035
Carena 20081
Carrefour 20045
Carver 20081
Casio 20000

Cathay 20278
CCE 20278
Centrum 21593
CGE 20000
Cineral 20278
Citizen 20278, 20037
Clatronic 20000, 21593
Condor 20278
Craig 20037
Crosley 20081
Crown 20278, 20037
Curtis Mathes 20035, 20162
Cyrus 20081
Daewoo 20278, 20642, 20045
Dansai 20278
Daytron 20278
De Graaf 20081, 20042
Decca 20081, 20000, 20067
Degraff 20081, 20042
Deitron 20278
Denon 20081, 20042
Diamant 20037
Dual 20081, 20278, 20348, 20000
Dumont 20081, 20000
Durabrand 20642, 21593
Elbe 20278, 20038
Electrophonic 20037
Elta 20278
Emerex 20032
Emerson 20278, 20037, 20000, 20045, 20043, 20039
ESC 20278
EuroLine 21593
Ferguson 20278, 20348, 20000, 20320, 20084
Fidelity 20000
Finlandia 20081, 20037, 20000, 20043, 20042, 20226
Finlux 20081, 20000, 20042
Firstline 20278, 20037, 20348, 20045, 20043, 20042
Flint 20348
Fuji 20033, 20035

Fujitsu 20037, 20000
Fujitsu Siemens 21972
Funai 20278, 20000, 21593
Galaxi 20000
Galaxis 20278
Garrard 20000
GE 20035, 20060
GEC 20081
General Technic 20348
GoldStar 20037, 20000, 20038, 20225
Goodmans 20081, 20278, 20037, 20348, 20000, 20642
GPX 20037
Gradiente 20000
Granada 20081, 20037, 20000, 20042, 20226, 20035
Grandin 20278, 20037, 20000
Grundig 20081, 20348, 20320, 20226
Hanseatic 20081, 20037, 20038
Harley Davidson 20000
Harman/Kardon 20038
Hewlett Packard 21972
Hinari 20278
Hischito 20045
Hitachi 20081, 20037, 20000, 20042
Hoeher 20278, 20642
Hornophon 20081
Hughes Network Systems 20042
Hypson 20278, 20037, 20000
Imperial 20000
Interbuy 20037
Interfunk 20081
Internal 20278
International 20278, 20037, 20642
Intervision 20278, 20037, 20348, 20000
Irradio 20081, 20037
ITV 20278, 20037
JBL 20278
JMB 20348
Joyce 20000
JVC 20067, 20084

Karcher 20081, 20278, 20642
KEC 20278, 20037
Kendo 20278, 20037, 20348, 20642
Kenwood 20067, 20038
Kneissel 20278, 20037, 20348
Kodak 20037, 20035
Lenco 20278
LG 20278, 20037, 20000, 20225
Lifetec 20348
Lloyd's 20000
Loewe 20081, 21562, 20037, 20162, 21062, 21162
Luxor 20043
LXI 20037
M Electronic 20037, 20000, 20038
Magnadyne 20081
Magnasonic 20278
Magnavox 20081, 20000, 20035, 20039, 21593
Magnum 20642
Manesth 20081, 20045
Marantz 20081, 20035, 20038
Mark 20278, 20000
Marta 20037
Mascom 20642
Mastec 20642
Master's 20278
Matsui 20037, 20348
Mediator 20081
Medion 20348, 20642
MEI 20035
Memorex 20037, 20348, 20000, 20035, 20039, 20162, 21162
Metronic 20081
Metz 20081, 21562, 20037, 20226, 20162, 21062, 21162
MGA 20043
Micromay 20348
Microsoft 21972
Migros 20000
Minolta 20042
Mitsubishi 20081, 20642, 20067, 20043
Motorola 20035

- MTC** 20000
Multitec 20037
Multitech 20000
Murphy 20000
Myriad 20081
Naiko 20348, 20642
NAP 20039
National 20226
Nebula Electronics 20033
NEC 20037, 20067, 20038
Neckermann 20081
Nesco 20000
Nikkai 20278
Nikko 20037
Nokia 20081, 20278, 20042
Nordmende 20642, 20320, 20067
Oceanic 20081, 20000, 20320
Okano 20278, 20348
Olympus 20226, 20035
Onimax 20642
Onkyo 20222
Optimus 20058, 20162, 21062, 21162
Orion 20348
Orson 20000
Osaki 20037, 20000
Otto Versand 20081
Pacific 20348, 20000, 20642
Packard Bell 21972
Palladium 20037, 20348
Palsonic 20000
Panama 20035
Panasonic 21562, 20000, 20226, 20035, 20162, 20225, 20616, 21062, 21162, 21244, 21293
Pathe Cinema 20043
Penney 20037, 20042, 20035, 20038
Pentax 20042
Perdio 20000
Philco 20035, 20038
Philips 20081, 20035, 20618
Phoenix 20278
Phonola 20081
Pilot 20037
Portland 20278
Precision 20058
Prinz 20000
Profitronic 20081
Proline 20278, 20000, 20642, 20320
Proscan 20060
Proscro 20278
Prosonic 20278
Protech 20081
ProVision 20278
Pulsar 20039
Pye 20081
Quasar 20278, 20035, 20162, 21162
Quelle 20081
Radialva 20081, 20037
Radiola 20081
Radionette 20037
RadioShack 20037, 20000
Radix 20037
Randex 20037
RCA 20320, 20042, 20035, 20060
Realistic 20037, 20000, 20035
Reoc 20348
Ricavision 21972
Roadstar 20081, 20278, 20037, 20038
Runco 20039
Saba 20278, 20320
Saisho 20348
Salora 20043
Samsung 20045, 20060
Sanky 20039
Sansui 20000, 20067
Sanyo 20067
Saville 20278
SBR 20081
Schaub Lorenz 20348, 20000
Schneider 20081, 20278, 20037, 20348, 20000, 20642, 20042
Scott 20043
Sears 20037, 20000, 20042, 20035
Seaway 20278
SEG 20081, 20278, 20642
SEI 20081
Sei-Sinudyne 20081
Seleco 20037
Semp 20045
Sentra 20278
Sharp 20807
Shivaki 20037
Siemens 20081, 20037, 20320
Siera 20081
Silva 20037
Silver 20278
SilverCrest 20642
Singer 20045
Sinudyne 20081
Smaragd 20348
Sontec 20278, 20037
Sony 20000, 20067, 20032, 20226, 20033, 20035, 20636
Soundwave 20037, 20348
Standard 20278
Stern 20278
STS 20042
Sunkai 20278, 20348
Sunstar 20000
Suntronic 20000
Supra 20037
Susumu 20037
Sylvania 20081, 20000, 20043, 20035
Symphonic 20000, 21593
T+A 20162
Tandberg 20278
Tandy 20000
Tashiko 20081, 20037, 20000
Tatung 20081, 20348, 20000, 20067, 20043
Tchibo 20348
TCM 20348
Teac 20037, 20000, 20642
Technics 20081, 20000, 20226, 20035, 20162, 21162
TechniSat 20348
Teknika 20037, 20000, 20035
Telefunken 20278, 20320
Teletext 20226
Teletch 20278, 20000
Tensai 20278, 20037, 20000
Tevion 20348, 20642
Texet 20278
Thomas 20000
Thomson 20278, 20320, 20067, 20060
Thorn 20037, 20320, 20084
Tisonic 20278
Tivo 20618
Tokai 20037
Topline 20348
Toshiba 20081, 20000, 20045, 20043
Totevision 20037
Tradex 20081
Ultravox 20278
United 20348, 21593
Universum 20081, 20037, 20348, 20000
Vector 20045
Vector Research 20038
VIA Technologies 21972
Victor 20067
Video Concepts 20045
Video Technic 20000
Videomagic 20037
Villain 20000
Wards 20081, 20000, 20045, 20042, 20033, 20035, 20038, 20039, 20058, 20060
Watson 20081, 20642
Weltblick 20037
White Westinghouse 20278
World 20348
XR-1000 20000, 20035
Yamaha 20038
Yamishi 20278
Yoko 20037
Zenith 20000, 20033, 20039
ZX 20348
PVR
Pioneer 22306, 22465, 22466, 22467
Microsoft 21972
Panasonic 20616
Philips 20618
VCR/PVR Combination
JVC 20067

DVD

General

- Pioneer** 30571, 30525, 30142, 30631, 30632, 31460, 31571, 32442
3D LAB 30539
4Kus 31158
A-Trend 30714
Acoustic Solutions 30730, 30713, 31228
AEG 30770, 30790, 30675, 30788, 31233
AFK 31051, 31152
AG Electronics 31228
Aim 30778
Airis 30672, 30826, 31005, 31107, 31224, 31321, 31338
Aiwa 30533, 30641
Akai 30790, 30788, 30898, 30899, 31115, 31233
AKI 31005
Akura 30898, 31051, 31140, 31233, 31367
Alba 30539, 30695, 30730, 30672, 30713, 30783, 31140, 31530
Alize 31151
Altacom 31224
Amitech 30770, 30784, 30850
Amoi 30852
Amstrad 30770, 30790, 30713, 31151, 31367
Amuseur 31351
AMW 30872
Ansonic 30831, 30759, 31351
Apex Digital 30672, 30794, 31004
Arena 31115
Aristona 30539, 30646
Asono 31224
Atacom 31224
Audiovision 30690
Audix 30713
Autovox 30713
Auvio 30843
Axion 30730
Basic Line 30713
Baze 30898
BBK 31224, 31338, 32168
Bellagio 31004
Bellwood 30826
Belson 31086
Black Diamond 30713
Blusens 31233, 31321
Blue Nova International 31321
Blue Sky 30695, 30651, 30790, 30672, 30713, 30778, 30843, 31423
Boghe 31004
Boman 30783, 30898, 31005
Brainwave 30770, 31115
Brandt 30503, 30551, 30651
Broksonic 30695
Bush 30730, 30831, 30672, 30690, 30713, 30723, 30733, 30778, 31051, 31128, 31140, 31351, 31367, 31483, 31530
Cambridge Audio 30751
Campomatic Digital 31051
Cat 30789, 31421
CC 30730
Centrum 30675, 30713, 30779, 30789, 31005, 31227
CGV 30733, 30751, 31115
Cinea 30841
Cinetec 30713, 30872
Classic 30730
Clatronic 30672, 30675, 30788, 31233
Clayton 30713
Coby 30730, 30778, 30852, 31351
Codex 31233
Commmax 31321, 31338
Compacts 30826, 31107
Conia 30852
Contel 30788
Continental Edison 30831, 30872
Crown 30770, 30690, 30713, 31115
Crypto 31228
Cybercom 30831
CyberHome 30714, 30816, 30874, 31023, 31502
Cytron 30651, 31347, 31423
D-Vision 31115, 31367
Daenyx 30872
Daewoo 30770, 30714, 30872, 31483
Dalton 31036
Dansai 30770, 30783, 31115
Dantax 30539, 30790, 30713, 30723
Daytek 30872, 31005
Dayton 30872, 31158
DCE 30831
Decca 30770, 31115
Denon 30490, 30634, 31634, 32258
Denver 30672, 30778, 30788, 30898, 31056, 31107, 31321, 31338
Denzel 30665
Desay 30843
Dgtec 30672
Diamond 30651
Digihome 30713
DigiLogic 30713
Digiton 30690
Digitrex 31056
Digix Media 30826
DiK 30831
Dinamic 30788
Disney 30831, 31270
DK Digital 30831, 32095
DMTech 30783
Dragon 30831
DreamX 31151
Dual 30730, 30831, 30651, 30790, 30665, 30713, 30779, 30783, 31023, 31530
Durabrand 30831, 30675, 30713, 31023, 31502, 31530
E:max 31233, 31321
eBench 31152
ECC 30730
Eclipse 30723, 30751
Electrohome 32116
Elfunk 30713, 30850
Elin 30770
Ellion 30850, 31421
Elta 30770, 30672, 30690, 30784, 30788, 30850, 31051, 31115, 31151, 31233
Eltax 31233, 31321
Emerson 30591
Enterprise 30591
Enzer 31228
EuroLine 30675, 30788, 31115, 31233, 31351
Fenner 30651
Ferguson 30695, 30651, 30713, 30898
Finlux 30741, 30591, 30770, 30672, 30751, 30783
Fintec 31530

- Firstline** 30713, 30843, 30869, 31530
Fisher 30670
Funai 30695, 30675
Gateway 31158
Germatic 31051
Global Link 31224
Global Solutions 30768
Global Sphere 31152
Go Video 30783, 30869
GoldStar 30741, 30591
Goodmans 30730, 30651, 30790, 30690, 30713, 30723, 30783, 31004, 31140, 31152, 31423, 31530
GPX 30741
Graetz 30665
Gran Prix 30831, 30898
Grandin 30713, 31233
Grundig 30539, 30551, 30695, 30651, 30790, 30670, 30713, 30775, 31004, 31036, 31128
Grunkel 30770, 30831, 30790
GVG 30770
H & B 30713, 30841, 30850, 31233, 31421
Hanseatic 30741, 30790, 30783
Harman/Kardon 30582, 30702
HCM 30788
HE 30730
Henss 30713
HiMAX 30843
Hitachi 30573, 30664, 30141, 30665, 30713, 31664, 31764
Hiteker 30672
Hoehner 30831, 30651, 30713, 30826, 31004, 31224, 31530
Home Electronics 30770, 30730
Home Tech Industries 31107, 31224
HotMedia 31152
Humax 30646
HYD 31233
Hyundai 30850
Iekei 31107
Ingelen 30788
Ingersol 31023
Initial 31472
Inno Hit 30713
Irradio 30869, 31115, 31224, 31233
IRT 30783
ISP 30695
Jamo 31036
Jaton 30665
JDB 30730
JDV 31367
JGC 31530
JMB 30695
JVC 30623, 30539, 30503, 30558, 30867, 31164, 31275, 31550
jWin 31051
Kansai 31107
Kansas Technologies 31233, 31530
Karcher 30783, 31367
Kendo 30831, 30672, 30713, 31483
Kennex 30770, 30713, 30898
Kenwood 30490, 30534
Kiirio 30770
Kiss 30665, 30841
KLH 31149
Kreisen 31421
KXD 31107, 31321
Lawson 30768
Leiker 30872
Lenco 30770, 30651, 30713, 30778
Lenoir 31228
Lexia 30768
LG 30741, 30591, 30790, 30869
Lifetec 30831, 30651, 31347
Limit 30768
LiteOn 31058, 31158, 31416
Lodos 30713
Loewe 30539, 30741, 30511
Logik 30713
Logix 30783
Luker 31367
Lumatron 30741, 30695, 30713, 31115, 31321
Lunatron 30741
Luxman 30573
Luxor 30713, 31004
Magnavox 30539, 30503, 30646, 30675, 30713, 30821, 31140
Magnex 30723
Majestic 31107
Manhattan 30713
Marantz 30539
Mark 30713
Marquart 30770
Mastec 31338
Matsui 30695, 30651, 30672, 30713, 31004
Maxim 30713, 30872, 31367
MBO 30730, 30690
MDS 30713, 30778
Mecotek 30770
Mediencom 30751
Medion 30741, 30630, 30831, 30651, 30783, 31107, 31270, 31347, 31423
MEI 30790
Memorex 30831
Metronic 30690
Metz 30571, 30525, 30713
MICO 30723, 30751, 31223
Micromaxx 30695
Micromedia 30539, 30503
Micromega 30539, 31005
Microsoft 30522, 32083
Microstar 30831
Minato 30752
Minax 30713
Minoka 30770, 31115
Mirror 30752
Mitsubishi 30521, 30713, 31403
Mizuda 30770
Monyka 30665
MPX 30843
Mustek 30730
Mx Onda 30651, 30751, 31223
Mystral 30831
NAD 30741
Naiko 30770, 31004, 31367
Nakamichi 31222
Narita 31367
NEC 30785
Neufunk 30665
Nevir 30770, 30831, 30672
Nexius 30790
NFRENS 30826
Nintaus 31051
Nordmende 30831
Noriko 30752
Okano 30752
Olidata 30672
Onkyo 30503, 30612, 30627, 31612, 31769, 32147
Oopla 31158
Oppo 30675
Optim 30843
Optimus 30525
Orbit 30872
Orion 30695, 30713, 31128, 31233
Oritron 30651
Ormond 30713
Pacific 30831, 30768, 30790, 30713, 30759
Packard Bell 30831, 31321
Palladium 30695, 30713, 30779
Panasonic 30490, 30632, 30703, 31010, 31011, 31579, 31641
Panda 30789, 31107
Paramount Pictures 30779
peekTOn 30898, 31224
Philco 30690, 30733
Philips 30539, 30503, 30646, 30675, 30854, 31158, 31267, 31340, 31354, 31506, 32056, 32084
Plu2 30850
Powerpoint 30872, 31005
Prinz 30831
Prism 30831
ProCaster 31004
Proline 30651, 30672, 30710, 31004, 31483
Proscan 30522
Proson 30713
Prosonic 30752
ProVision 30730, 31107, 31321
Pye 30539, 30646
QONIX 30790, 31051
Radionette 30741, 30869
Radiotone 30713
RAICE 30665
RCA 30522
REC 30490
Redstar 30770, 30759, 30763, 30788, 30898, 31107
Relisys 31347
Reoc 30768, 30752
Revoy 30841
Richmond 31233
Roadstar 30730, 30672, 30690, 30713, 30898, 31051, 31227
Ronin 30710, 30872
Rotel 30623, 30558, 31178
Rownsonic 30789
Saba 30551, 30651
Saivod 30831, 30759, 31367
Salora 30741
Sampo 31321
Samsung 30490, 30573, 30199, 30744, 30899, 31044, 31075, 31635, 31748, 32107, 32269
Sansui 30695, 30751, 31228
Sanyo 30670, 30713, 31228
Scan 30850
ScanMagic 30730
Schaub Lorenz 30770, 30788, 31115, 31151
Schmartz 32367
Schneider 30539, 30831, 30646, 30651, 30790, 30713, 30779, 30783, 30788, 30869, 31227, 31367
Schoentech 30713
Schwaiger 30752
Scientific Labs 30768
Scott 30651, 30672, 31005, 31036, 31233, 31423
Seeltech 31224, 31338
SEG 30665, 30713, 30763, 30872, 31483, 31530
Shanghai 30672
Sharp 30630, 30675, 30713, 30752, 30869, 31256, 32250
Sherwood 30741
Sigmatek 31005, 31224
Siltex 31224
Silva 30788, 30898
Silva Schneider 30741, 30831, 30869, 30898, 31367
SilverCrest 31152
Sistemas 30672
Skantic 30539, 30713
Skymaster 30730, 30768
Skyworth 30898
Sliding 31115
SM Electronic 30730, 30768, 30690, 31152
Smart 30713
Sonic Blue 30783
Sony 30533, 30864, 31033, 31069, 31070, 31431, 31516, 31533, 31536
Sound Color 31233
Soundmaster 30768
Soundwave 30713, 30783, 31530
Standard 30831, 30768, 30651, 30788, 30898
Star Clusters 31152, 31227
Starlogic 31005
Starmedia 31005, 31224
Strato 31152
Strong 30713
Sunkai 30770, 30850
Sunstech 30831
Sunwood 30788, 30898
Supervision 30768, 31152
SVA 30672, 30752
Sylvania 30675, 32194
Symphonic 30675
Synn 30768
Syscom 30826
TAG McLaren 30894
Tandberg 30713
Tangent 31321
Targa 30741, 31227
Tatung 30770
Tchibo 30741
TCM 30741, 30790
Teac 30741, 30768, 30759, 31227
Tec 30898
Technica 31367
Technics 30490, 30703
Technika 30770, 30831, 31115, 31530
Technisson 31115
Technosonic 31051, 31115, 31367
Techwood 30713, 31530
Tedalex 31228
Telefunken 30551
Teletch 30768, 30713
Tensai 30770, 30651, 30690
Tevion 30651, 30898, 31036, 31227, 31483
Theta Digital 30571
Thomson 30551, 30522
Tokai 30790, 30665, 30784, 30788, 30898, 31233
Tom-Tec 30789
Top Suxess 31224
Toshiba 30503, 30695, 31045, 31510, 31515, 31608, 31639, 31769
Tosumi 31367
TProgress 30752
TRANS-continentals 30831, 30826, 30872, 31233, 31321
Tredex 30843
Trevi 30831
TSM 31224
TVE 30713
Umax 30690, 31151
United 30695, 30730, 30675, 30713, 30788, 30826, 31115, 31152, 31228, 31233, 31351, 31367
Universum 30741, 30591, 30790, 30713, 30779, 30869, 31227, 31530
Uptek 30763
Venturer 30790, 31769
Vestel 30713, 31530
Voxson 30730, 30831
Vtrek 31228
Waitec 30730, 31151, 31224, 31233
Waltham 30713, 31530
Welkin 30831
Wellington 30713
Weltstar 30713
Wharfedale 30790, 30713, 30751, 30752, 31115
Wilson 30831, 31233
Windsor 30713
Windy Sam 30573
Woxter 31005, 31151, 31224, 31338
Xbox 30522, 32083
Xenius 30790
Yakumo 31004, 31056
Yamada 30872, 31004, 31056, 31151, 31158, 31416
Yamaha 30490, 30539, 30646, 30497, 30545, 30817
Yamakawa 30665, 30710, 30872
Yukai 30730
Zenith 30503, 30591
Blu-ray
Pioneer 30142, 32442
Denon 32258
LG 30741
Onkyo 32147
Panasonic 31641
Philips 32084
Samsung 30199
Sharp 32250
Sony 31516
HD-DVD
LG 30741
Microsoft 32083

Onkyo 31769
Toshiba 31769
Xbox 32083
DVD-R
Pioneer 30631, 31460
4Kus 31158
Airis 31321, 31338
Alba 31530
Aristona 30646
BBK 31338
Belson 31086
Bush 31530
Cat 31421
Centrum 31227
Commax 31321, 31338
CyberHome 31502
Cytron 31347
Dayton 31158
Denver 31056, 31338
Digitrex 31056
Dual 31530
Durabrand 31502, 31530
E:max 31321
Electrohome 32116
Ellion 31421
Eltax 31321
Fintec 31530
Firstline 31530
Funai 30675
Gateway 31158
Goodmans 31530
GPX 30741
H & B 31421
Hitachi 30141
Hoeher 31530
Humax 30646
JGC 31530
JVC 31164, 31275

Kansas Technologies 31530
Kreisen 31421
KXD 31321
LG 30741
Lifetec 31347
LiteOn 31158, 31416
Loewe 30741
Lumatron 31321
Mastec 31338
Medion 30741, 31347
MiCO 30751
Oopla 31158
Packard Bell 31321
Panasonic 30490, 31010, 31011, 31579
Philips 30646, 31158, 31506
ProVision 31321
Pye 30646
Relisys 31347
Roadstar 31227
Samsung 31635, 31748, 32107
Schneider 30646, 31227
Seeltech 31338
SEG 31530
Sony 31033, 31069, 31070
Soundwave 31530
Star Clusters 31227
Sylvania 30675
Tangent 31321
Targa 30741, 31227
Teac 31227
Technika 31530
Techwood 31530
Tevion 31227
Thomson 30551
Toshiba 31510
Universum 31227, 31530
Vestel 31530
Waltham 31530
Woxtter 31338

Yakumo 31056
Yamada 31056, 31158, 31416
Yamaha 30646

DVD/PVR Combination

Pioneer 30631
Airis 31321
Blu:sens 31321
GPX 30741
Hitachi 30141
JGC 31530
JVC 30623
LG 30741
LiteOn 31416
Medion 30741
Mitsubishi 31403
Panasonic 30490, 31010, 31011, 31579
Philips 30539, 31158, 31340
Samsung 30490, 31635, 32107
SEG 31530
Sharp 31256
Silva Schneider 30741
Sony 31033, 31069, 31070, 31536
Soundwave 31530
Targa 30741
Chibo 30741
TCM 30741
Technika 31530
Thomson 30551
Toshiba 31510, 31639
Universum 30741
Yamada 31416

DVD/VCR Combination

Pioneer 31460
AEG 30675
Brokronic 30695

Bush 31483
Centrum 30675
Clatronic 30675
Daewoo 31483
Durabrand 30675
EuroLine 30675
Firstline 30869
Funai 30695, 30675
Go Video 30869
GoldStar 30741
Hitachi 30664, 30141
Irradio 30869
JVC 30867, 31164, 31550
Kendo 31483
LG 30741, 30869
Lumatron 30741, 30695
Lunatron 30741
Magnavox 30675
Micromaxx 30695
Orion 30695
Panasonic 30490, 31579
Philips 30539, 30646, 30675, 31267
Proline 31483
Radionette 30869
Samsung 30744, 31075, 32269
Sanyo 30670
Schneider 30869
SEG 31483
Sharp 30630, 30869
Silva Schneider 30869
Sony 30864
Symphonic 30675
Tevion 31483
Thomson 30551
Toshiba 30503, 31045, 31510
United 30675
Universum 30869

CD

General

Pioneer 70032, 70468, 70101, 71063, 71087, 73468
Advantage 70032
AH! 70157
Aiwa 70157
Arcam 70157
Atoll Electronique 70157
Audio Research 70157
Audiolab 70157
Audiomeca 70157
Audioton 70157
AVI 70157
Balanced Audio Technology 70157
Bush 70388
Cairn 70157
California Audio Labs 70029
Cambridge 70157
Cambridge Audio 70157
Cambridge Soundworks 70157
Carver 70157
Cyrus 70157
Denon 70626, 70034, 70766
DKK 70000
DMX Electronics 70157
Dynaco 70157

Genexxa 70000, 70032, 70037
Goldmund 70157
Grundig 70157
Harman/Kardon 70157
Inkel 70157, 70180
JVC 70072
Kenwood 70157, 70028, 70626, 70037
Krell 70157
Linn 70157
Loewe 70157
Magnavox 70157
Marantz 70157, 70029, 70626, 70180
Matsui 70157
MCS 70029
Memorex 70000, 70032, 70468, 70180
Meridian 70157
Micromega 70157
Miro 70000
Mission 70157
Modulaire 70000, 70032, 70468, 70087, 70180
Myryad 70157
NAD 70000
Naim 70157

Onkyo 70101, 70102, 70138, 70381, 70868, 71322, 71323, 71327
Optimus 70000, 70032, 70468, 71063
Panasonic 70029, 70388, 70752
Philips 70157, 70626
Primare 70157
Proton 70157
QED 70157
Quad 70157
Quasar 70029
Radiola 70157
RCA 70053
Realistic 70180
Restek 70157
Revox 70157
Rotel 70157
SAE 70157
Saisho 70000
Sansui 70157
Sanyo 70087
Sharp 70037, 70180
Sherwood 70180
Siemens 70157
Simaudio 70157
Sony 70000, 70100, 71364
Sylvania 70157
Symphonic 70180
TAG McLaren 70157

Tandy 70032
Technics 70029
Thomson 70053
Thorens 70157
Thule Audio 70157
Traxdata 70626
Universum 70157, 70053
Victor 70072
Wards 70000, 70157, 70032, 70053, 70087
Yamaha 70036, 71292

CD-R

Pioneer 71087
Kenwood 70626
Onkyo 71322, 71323
Philips 70626
Sony 70100
Thomson 70053
MD
Pioneer 71063
Onkyo 70868
Sony 70000

Satellite Set Top Box

General

Pioneer 00853, 00329, 01308
@sat 01300
@Sky 01334

Acoustic Solutions 01284
ADB 00642, 02367
Akai 00200
Alba 01284
Allsat 00200

Allvision 01232, 01334, 01412
Amstrad 00847, 01175, 01113
Ansonic 02418
Apro 01672
Armstrong 00200

Arnion 01300
Asat 00200
ASCI 01334
AssCom 00853
Astro 00173, 01100, 01113

- Atlanta** 02418
Atsat 01300
AtSky 01334
Audioline 01672
Austar 00879, 00642
Axil 01457, 02418
Axitronic 01626
B@ytronic 01412
Balmet 01457
Belson 02418
Big Sat 01457
Black Diamond 01284
Blaupunkt 00173
Boca 01232
Boston 01251
Brainwave 01672
British Sky Broadcasting 00847, 01175
BskyB 00847, 01175
Bush 00560, 01284, 01291, 01645, 01672, 01974
Canal Digital 00853
Canal Satellite 00853, 02107
Canal+ 00853, 02107
CGV 01567
Chaparral 00216
Chess 01334, 01626
CityCom 01176, 01232, 01781
Classic 01672
Comag 01232, 01412
Coship 01457, 01672
Crown 01284
Cyfra+ 01076
Cyrus 00200
D-box 00723, 01114
Daewoo 01974
Dantax 01626
Denver 02418
Digitality 01334
Digifusion 01645
Digihome 01284
DigiLogic 01284
DigiQuest 01300, 01457
DigiSat 01232
Digisky 01457
Digiturk 01076
DirectTV 00099
Dish Network System 00775
DNT 00200
Dream Multimedia 01237
DSTV 01433
Durabrand 01284
Echostar 00853, 00775, 01323, 01409
Elap 01567
Elbe 02418
Elta 00200
eMTech 01214
Engel 01251
EuroLine 01251
Expressvu 00775
Ferguson 01291
Finlux 01626
Fly Com 01457
FMD 01457
Fortec Star 01821
Foxtel 00879
Fuba 00173, 01214, 01251
Galaxis 00853
GbSAT 01214
Gecco 01412
General Satellite 01176
Globo 01251, 01334, 01412, 01626
GOD Digital 00200
Gold Box 00853
Goodmans 00560, 01284, 01291, 02337
Gradiente 00887
Grandin 01626
Grocos 01457
Grundig 00847, 00853, 00173, 00879, 01284, 01291, 01672
Hama 01567
Hanseatic 01100
Hauppauge 01672
HB 01214
Hirschmann 00173, 01232, 01412
Hitachi 00819, 01284
Hornet 01300
HTS 00775
Hughes Network Systems 00749
Humax 01176, 01427, 01781, 01808, 01882, 01915, 02144, 02357, 02408
i-CAN 02367
ID Digital 01176
Imperial 01195, 01334, 01672
Inno Hit 01626
Interstar 01214
ITT Nokia 00723
Jaeger 01334
JVC 00492, 00775
Kaon 01300
Kathrein 00173, 00200, 01416, 01567
Kenwood 00853
Kreiling 01626
Kreiselmeyer 00173
L&S Electronic 01334
LaSAT 00173
Leiko 01626
Lemon 01334
Listo 01626
Lodos 01284
Logik 01284
Magnavox 00722
Manhattan 01300
Marantz 00200
Maspro 00173
Matsui 00173, 01284, 01626
Maximum 01334
Mediabox 00853
Mediacom 01206
MediaSat 00853, 02107
Medion 01232, 01334, 01412, 01626
Mega 00200
Metronic 01334
Metz 00173
Morgan's 00200, 01232, 01412
Multibroadcast 00879, 00642
Multichoice 00879, 00642, 01433, 01959, 01960
Myryad 00200
MySky 01848
NEOTION 01334
Netsat 00887, 00099
Neuling 01232
Nichimen 00560
Nikko 00723, 00200
Nokia 00853, 00723, 01223
OctalTV 01505
Onn 01284
Opentel 01232, 01412
Optex 01611, 01626
Optus 00879
Orbis 01232, 01334, 01412
Orbitech 01100, 01195
P/Sat 01232
Pace 00847, 00853, 00200, 00887, 01175, 00329, 01323, 01423, 01848
Pacific 01284
Palcom 01409
Panasat 00879, 01433
Panasonic 00847, 00701, 01304
Panda 00173
Pansat 01807
Pass 01567
peekTon 01457, 02418
Philips 00853, 00173, 00200, 01114, 00099, 00722, 01076, 01672, 02107, 02176
Phoenix 02418
Pino 01334
Pixx 01807
PMB 01611
Preisner 01113
Premier 00723, 02176
Proline 01284
Proscan 00392
Radiola 00200
Radix 01113
RCA 00143, 00392, 00566
Rebox 01214
Regal 01251
RFT 00200
Roadstar 00853
Rownsonic 01567
SAB 01251, 01300
Saba 00820
Sagem 00820, 01114, 02107
Saivod 02418
Samsung 00853, 01206, 01458, 01570
Sanyo 01626
Sat Control 01300
SAT+ 01409
Satelco 01232
Satplus 01100
Schaub Lorenz 01214
Schneider 01206, 01251
Schwaiger 01334, 01412, 01457, 01672
Sedea Electronique 01206, 01626
SEG 01251, 01626
Serd 01412
Servimat 01611
ServiSat 01251
Siemens 00173, 01334
Sigmathek 02418
SKY 00847, 00887, 01175, 00099, 01848
SKY Italia 00853, 01848
Sky XL 01251, 01412
Sky+ 01175
Skymaster 01334, 01409, 01567, 01611
Skymax 00200
Skyplus 01175, 01232, 01334, 01412
Skyvision 01334
SL 01672
SM Electronic 01409
Smart 01113, 01232
Sony 00847, 00853, 00639, 01558
Star Sat 01214
Starlite 00200
Stream 01848
Stream System 01300
Strong 00853, 00820, 00879, 01284, 01409, 01626, 02418
Sumin 01412
Sunny 01300
Sunstar 00642
Supernova 00887
Systec 01334
Targa 01807
TBoston 01251, 02418
Technical 01626
TechniSat 01100, 01195
Technosonic 00560, 01672
Technotrend 01672
Techwood 01284, 01626
TELE System 01251, 01409, 01611
Telestar 01100, 01195, 01251, 01334, 01626, 01672
Televés 01214, 01300, 01334
Televisa 00887
Telewire 01232
Tevion 00560, 01409, 01672
Thomson 00847, 00853, 00820, 01175, 00392, 01046, 01291, 02107, 02176
Tiny 01672
Tokai 00200
Tonna 01611
Topfield 01206, 01208
Toshiba 00749, 00790, 01284
TPS 00820
Trevi 01251
Triax 00853, 00200, 01113, 01251, 01291, 01611, 01626
Twinner 01611
UEC 00879
Uniden 00722
Unisat 00200
United 01251
Universum 00173, 01251
Variosat 00173
VEA 02418
Ventana 00200
Vestel 01251, 01284
Victor 00492
Viola Digital 01672
Vision 01626
Visiosat 00560, 01457, 01807
Wharfedale 01284
Wisi 00173, 01232
Worldsat 01214, 01251
Woxter 02418
Xoro 01807
Xsat 00847, 01214, 01323
Xtreme 01300
Yes 00887
Zehnder 01232, 01251, 01334, 01412
Zeta Technology 00200
SAT/PVR Combination
@sat 01300
Allvision 01412
Amstrad 01175
Atsat 01300
B@ytronic 01412
British Sky Broadcasting 01175
BskyB 01175
Bush 00560, 01645
Comag 01412
Daewoo 01974
Digifusion 01645
DigiQuest 01300
Digiturk 01076
Dish Network System 00775
Dream Multimedia 01237
eMTech 01214
GbSAT 01214
Gecco 01412
Globo 01412
Goodmans 00560
Hirschmann 01412
Humax 01176, 01427, 01808, 02144, 02357
Maximum 01334
Mediacom 01206
MediaSat 02107
Medion 01412
Morgan's 01412
MySky 01848
NEOTION 01334
Nichimen 00560
Opentel 01412
Orbis 01412
Pace 01175, 01423
Panasonic 01304
Philips 00099
Pixx 01807
Proscan 00392
Rebox 01214
Samsung 01206, 01570
Sat Control 01300
Schneider 01206
Schwaiger 01412
Sedea Electronique 01206
Serd 01412
SKY 01175, 01848
SKY Italia 01848
Sky XL 01412
Skyplus 01175, 01334, 01412
Stream System 01300
Sumin 01412
Sunny 01300
Targa 01807
TechniSat 01195
Technosonic 00560
Telestar 01195
Thomson 01175
Topfield 01206
Visiosat 00560, 01807
Xoro 01807
Xtreme 01300
Zehnder 01412

Cable Set Top Box

General

Pioneer 00144, 00533, 00877, 01782

ABC 00008, 00237

ADB 01585

Austar 00276

Birmingham Cable Communications 00276

Cable & Wireless 01068

Daeryung 00008

Encon 00008

Fosgate 00276

France Telecom 00817

Freebox 01482, 01976

Galaxi 00008

GE 00237

General Instrument 00276, 00476

GoldStar 00144

Humax 00660, 01813, 01885, 01981, 01983, 02142, 02447

i-CAN 01585

Jerrold 00276, 00476, 00810

Kabel Deutschland 01958, 01981, 01983

Macab 00817

Matav 01082

Memorex 00000

Motorola 00276

Noos 00817

Nova Vision 00008

NTL 01068, 01060, 00276

Ono 01068

Optus 00276

Orange 00817

Pace 01068, 01060, 00237, 01577

Panama 00107

Panasonic 00000, 00107, 00144

Paragon 00000

Philips 00817, 01582, 01619, 01958, 02174

Premier 02174

Pulsar 00000

Runco 00000

Sagem 00817

Salora 00000

Samsung 01060, 00000, 00144,

01666, 02015, 02174

Satbox 00375

Scientific Atlanta 00008, 00237,

00877, 01987

StarHub 00276, 01927

Supercable 00276

Telefonica 01585

Telenet 01920

Telewest 01068, 01987

Thomson 01256, 01582, 01958,

01981, 01983, 02174

Toshiba 00000

UPC 01582

US Electronics 00276

Virgin Media 01068, 01060, 01987

Visiopass 00817

Zenith 00000, 00525

Cable/PVR Combination

Freebox 01482, 01976

Humax 01813, 01885, 01981, 01983, 02142

Philips 01619

Scientific Atlanta 01987

StarHub 01927

Telenet 01920

Telewest 01987

UPC 01582

Virgin Media 01987

Laser Disc Player

Pioneer 30241, 32447

Denon 30241

Magnavox 30241

Cassette Deck

Pioneer 40027, 42446

Aiwa 40029

Arcam 40076

Audiolab 40029

Carver 40029

Denon 40076

Grundig 40029

Inkel 40070

JVC 40244

Kenwood 40070

Magnavox 40029

Marantz 40029

Myryad 40029

Onkyo 40135

Optimus 40027

Philips 40029

Radiola 40029

Revox 40029

Sansui 40029

Sony 40243

Thorens 40029

Victor 40244

Wards 40029, 40027

Yamaha 40097

Digital Tape

Pioneer 40019

Onkyo 40019

Tascam 40019

Tascam 40019

Video Accessory

Pioneer 01010

Acer 01272

ADB 02586

Amino 01481

Daily Media 01272

Dgtec 01363

Fujitsu Siemens 01272

Hewlett Packard 01272

Kreatel 01385

Microsoft 01272, 02049

Packard Bell 01272

Philips 01272

Ricavision 01272

Sharp 01010

Sylvania 01563

VIA Technologies 01272

Xbox 02049

Specifications

- These specifications are applicable when the power supply is 230 V.

Audio section

Rated power output (1 kHz, 6 Ω, 1 %)	
Front	150 W + 150 W
Center	150 W
Surround	150 W + 150 W
Surround back	150 W + 150 W
Rated power output (20 Hz to 20 kHz, 8 Ω, 0.09 %)	
Front	110 W + 110 W
Center	110 W
Surround	110 W + 110 W
Surround back	110 W + 110 W
Total Harmonic Distortion (20 Hz to 20 kHz, 8 Ω, 100 W + 100 W)	0.06 %
Guaranteed speaker impedance	
	16 Ω to 8 Ω, less than 8 Ω to 6 Ω (setting required)
Signal-to-Noise Ratio (IHF, short circuited, A network)	103 dB
Frequency Response	5 Hz to 100 000 Hz ±3 dB (Pure Direct Mode)
Input (Sensitivity/Impedance)	300 mV/47 kΩ
Output (Level/Impedance)	
REC	300 mV/2.2 kΩ

Tuner Section

Frequency Range (FM)	87.5 MHz to 108 MHz
Antenna Input (FM)	75 Ω unbalanced
Frequency Range (AM)	531 kHz to 1602 kHz
Antenna (AM)	Loop antenna (balanced)

Video Section

Signal level	
Composite/S-Video	1 Vp-p (75 Ω)
Component Video	Y: 1.0 Vp-p (75 Ω), PB, PR: 0.7 Vp-p (75 Ω)
Corresponding maximum resolution	
Component Video	1080p (1125p) (Video convert off)

Digital In/Out Section

HDMI terminal	19-pin (Not DVI)
HDMI output type	5 V, 100 mA
USB terminal	USB2.0 Full Speed (Type A)
iPod terminal	USB, and Video (Composite)

Integrated control section

Control (SR) terminal	Ø 3.5 Mini-jack (MONO)
Control (IR) terminal	Ø 3.5 Mini-jack (MONO)
IR signal	High Active (High Level: 2.0 V)
12 V Trigger terminal	Ø 3.5 Mini-jack (MONO)
12 V Trigger output type	12 V, Total 50 mA
RS-232C cable type	9-pin, cross type, female-female

Miscellaneous

Power requirements	AC 220 V to 230 V, 50 Hz/60 Hz
Power consumption	410 W
In standby	0.5 W (KURO LINK OFF) 0.8 W (KURO LINK ON)
Dimensions	420 (W) mm x 173 (H) mm x 433 (D) mm
Weight (without package)	13.5 kg

Furnished Parts Number

MCACC Setup microphone (APM7009)	1
Remote control unit (AXD7547)	1
AA/IEC R6 dry cell batteries	2
iPod cable (ADE7129)	1
AM loop antenna	1
FM wire antenna	1
Power cord	1
Warranty card	1
These operating instructions	



Note

- Specifications and the design are subject to possible modifications without notice, due to improvements.

Cleaning the unit

- Use a polishing cloth or dry cloth to wipe off dust and dirt.
- When the surface is dirty, wipe with a soft cloth dipped in some neutral cleanser diluted five or six times with water, and wrung out well, and then wipe again with a dry cloth. Do not use furniture wax or cleansers.
- Never use thinners, benzine, insecticide sprays or other chemicals on or near this unit, since these will corrode the surface.

Our philosophy

Pioneer is dedicated to making your home theater listening experience as close as possible to the vision of the moviemakers and mastering engineer when they created the original soundtrack. We do this by focusing on three important steps:

- 1 Designing with carefully selected components so as to transmit the original soundtrack accurately
- 2 Allowing for customized acoustic calibration according to any listening area
- 3 Tuning that transmits soul

This product includes FontAvenue® fonts licenced by NEC corporation. FontAvenue is a registered trademark of NEC Corporation

Index

Numerics

12V trigger **34**

A

Acoustic Cal EQ **81**
 Acoustic Calibration EQ **60**
 Acoustic Calibration EQ Adjust **77**
 Acoustic Calibration EQ Professional **77**
 Advanced MCACC **71-83**
 Output PC **34, 81**
 Advanced surround **51**
 Analog attenuator **64**
 Aspect **62**
 Audio cable **21**
 AUDIO PARAMETER **60**
 Auto delay **61**
 Auto level control (ALC) **50, 104**
 Auto MCACC **39, 72**
 Auto surround **50, 104**

B

Bass **60**
 Bi-amp **16, 20, 21, 85**
 Bi-wiring **20**
 Brightness **62**

C

Center Image **61**
 Center Width **61**
 Channel Level **80, 86**
 Chroma Level **62**
 Contrast **62**
 CONTROL jack **33**

D

Data Management **82**
 DeepColor **26**
 Default system settings **66**
 Demo **71**
 Detail **62**
 Dialog Enhancement **60**
 Digital Noise Reduction **60**
 Digital Video Conversion **62**
 Dimension **61**
 Display **12, 65, 96**
 Dolby **50, 100**
 DTS **50, 101**
 Dual Mono **60**
 Dynamic Range Control **60**

E

Effect **61**

F

Fine Channel Level **75**
 Fine Speaker Distance **75**
 Flicker Reduction **90**
 Front Stage Surround Advance **52**

H

HDCP **26**
 HDMI **23-26, 35, 42, 57-59, 65, 97**
 HDMI Audio **61**
 Hue **62**

I

Input function **42**
 Default and possible settings **41**
 Input Setup **40-41**
 Input signal **55**
 iPod **36, 43-44, 101**
 Switching controls **44**
 IR jack **33**

K

KURO LINK **26, 57-59**

L

LFE Attenuate **60**
 Loudness **60**

M

Manual MCACC **74**
 Manual speaker setup **84**
 MCACC Data **80**
 MCACC preset **54, 60, 82**
 Midnight **60**
 Multi Zone **16, 19, 21, 31-32, 63, 85, 89**
 Multichannel analog input **28, 43, 89**

N

Neural THX **48, 103**

O

OSD Language (GUI) **38**

P

Panorama **61**
Phase control **55**
Placing **17**
Play **42**
Power cord **37**
Power ON Level **90**
PQLS **59**
Pre-out **29**
Preset code **105**
Progressive Motion **62**
Pure direct **53**
PureCinema **62**

R

RDS **49**
Recording **64**
Remote control **8, 9, 67-70, 90, 97, 105**
Reset **66**
Resolution **62**

S

SACD Gain **61**
Setup microphone **39, 73**
Sharpness **62**
Sleep timer **65**
Sound Delay **60**
Sound Retriever **60**
Speaker **16-21, 91**
Speaker B **16, 19, 21, 63, 85**
Speaker Distance **80, 87**
Speaker impedance **38**
Speaker Setting **80, 85**
Standard surround **50**
Standing Wave **60, 76**
Status **65**
Stream direct **53, 104**
Streo **52**
Surround back channel processing **53**
Surround back speaker **85**
Synchronized amp mode **59**
System Setup **84**

T

THX **17, 72, 87, 102**
 Home THX **51**
Tone Control **60**
Treble **60**
Troubleshooting **92**
Tuner **30, 48-49**

U

Up Mix **53**
USB **36, 45-47, 99**
 Playable file formats **47**

V

Video cable **22**
Video converter **22**
VIDEO PARAMETER **62**
Volume Limit **90**

W

WMA9 **101**
WMA9 Pro **29**

X

x.v.Color **26**
X-Curve **87**

Y

YNR **62**

Discover the benefits of registering your product online at <http://www.pioneer.co.uk>
(or <http://www.pioneer.eu>).

PIONEER CORPORATION

4-1, Meguro 1-Chome, Meguro-ku, Tokyo 153-8654, Japan

PIONEER ELECTRONICS (USA) INC.

P.O. BOX 1540, Long Beach, California 90801-1540, U.S.A. TEL: (800) 421-1404

PIONEER ELECTRONICS OF CANADA, INC.

300 Allstate Parkway, Markham, Ontario L3R 0P2, Canada TEL: 1-877-283-5901, 905-479-4411

PIONEER EUROPE NV

Haven 1087, Keetberglaan 1, B-9120 Melsele, Belgium TEL: 03/570.05.11

PIONEER ELECTRONICS ASIACENTRE PTE. LTD.

253 Alexandra Road, #04-01, Singapore 159936 TEL: 65-6472-7555

PIONEER ELECTRONICS AUSTRALIA PTY. LTD.

178-184 Boundary Road, Braeside, Victoria 3195, Australia, TEL: (03) 9586-6300

PIONEER ELECTRONICS DE MEXICO S.A. DE C.V.

Bldv.Manuel Avila Camacho 138 10 piso Col.Lomas de Chapultepec, Mexico,D.F. 11000 TEL: 55-9178-4270

K002_B_En

Published by Pioneer Corporation.
Copyright © 2009 Pioneer Corporation.
All rights reserved.

Free Manuals Download Website

<http://myh66.com>

<http://usermanuals.us>

<http://www.somanuals.com>

<http://www.4manuals.cc>

<http://www.manual-lib.com>

<http://www.404manual.com>

<http://www.luxmanual.com>

<http://aubethermostatmanual.com>

Golf course search by state

<http://golfingnear.com>

Email search by domain

<http://emailbydomain.com>

Auto manuals search

<http://auto.somanuals.com>

TV manuals search

<http://tv.somanuals.com>