

# PRO-FORM<sup>®</sup> 7.0

## PERSONAL FITNESS TRAINER

With Universal Dock for iPod<sup>®</sup>

Model No. PCTL57809.0

Serial No. \_\_\_\_\_

Write the serial number in the space above for future reference.

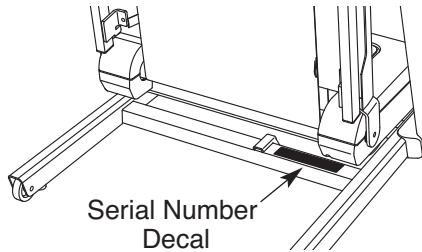

## USER'S MANUAL

### QUESTIONS?

If you have questions, or if parts are damaged or missing, **PLEASE CONTACT OUR CUSTOMER SERVICE DEPARTMENT DIRECTLY.**

CALL TOLL-FREE:

**1-888-936-4266**

Mon.–Fri., 8:00 until 17:00 ET  
(excluding holidays)

OR E-MAIL US:

[customerservice@iconcanada.ca](mailto:customerservice@iconcanada.ca)

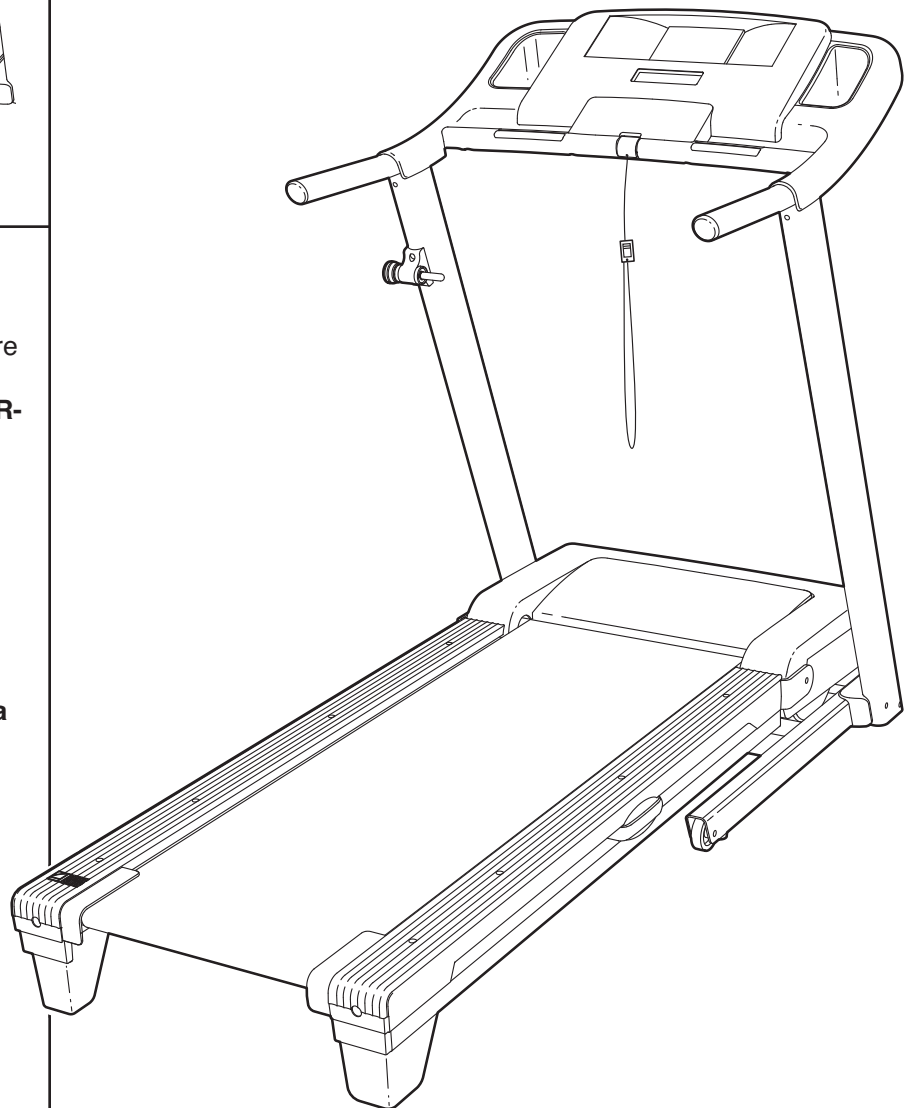

### CAUTION

Read all precautions and instructions in this manual before using this equipment. Save this manual for future reference.



[www.proform.com](http://www.proform.com)

# TABLE OF CONTENTS



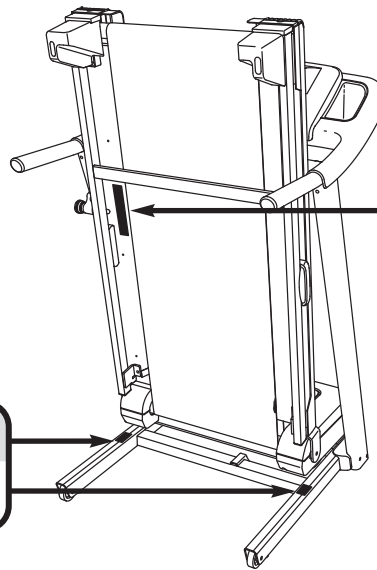

WARNING DECAL PLACEMENT .....2  
 IMPORTANT PRECAUTIONS .....3  
 BEFORE YOU BEGIN .....5  
 ASSEMBLY .....6  
 OPERATION AND ADJUSTMENT .....13  
 HOW TO FOLD AND MOVE THE TREADMILL .....23  
 TROUBLESHOOTING .....25  
 EXERCISE GUIDELINES .....28  
 PART LIST .....30  
 EXPLODED DRAWING .....32  
 ORDERING REPLACEMENT PARTS .....Back Cover  
 LIMITED WARRANTY .....Back Cover

## WARNING DECAL PLACEMENT

This drawing shows the locations of the warning decals. **If a decal is missing or illegible, call the telephone number on the front cover of this manual and request a free replacement decal. Apply the decal in the location shown.** Note: The decals may not be shown at actual size.



**WARNING:**  
 Protect yourself and others from risk of serious injury. Read the user's manual and:

-  •Stand only on the side rails when starting or stopping treadmill.
- Change speed in small increments.
- Hold handrails to prevent falling, and always wear the safety clip while operating treadmill.
- Stop if you feel faint, dizzy, or short of breath.
- Fully engage storage latch before treadmill is moved or stored.
- Reduce incline to its lowest level before folding treadmill into storage position.
-  •Never allow children on or around treadmill.
- Remove key when not in use.
-  •Keep clothing, fingers, and hair away from moving belt.
- Never try to adjust or fix the belt while it is moving.
-  •Always wear athletic shoes while operating treadmill.

# IMPORTANT PRECAUTIONS

**⚠ WARNING:** To reduce the risk of serious injury, read all important precautions and instructions in this manual and all warnings on your treadmill before using your treadmill. ICON assumes no responsibility for personal injury or property damage sustained by or through the use of this product.

1. Before beginning any exercise program, consult your physician. This is especially important for persons over age 35 or persons with pre-existing health problems.
2. It is the responsibility of the owner to ensure that all users of this treadmill are adequately informed of all warnings and precautions. Use the treadmill only as described.
3. Place the treadmill on a level surface, with at least 8 ft. (2.4 m) of clearance behind it and 2 ft. (0.6 m) on each side. Do not place the treadmill on any surface that blocks air openings. To protect the floor or carpet from damage, place a mat under the treadmill.
4. Keep the treadmill indoors, away from moisture and dust. Do not put the treadmill in a garage or covered patio, or near water.
5. Do not operate the treadmill where aerosol products are used or where oxygen is being administered.
6. Keep children under age 12 and pets away from the treadmill at all times.
7. The treadmill should be used only by persons weighing 300 lbs. (136 kg) or less.
8. Never allow more than one person on the treadmill at a time.
9. Wear appropriate exercise clothes while using the treadmill. Do not wear loose clothes that could become caught in the treadmill. Athletic support clothes are recommended for both men and women. *Always wear athletic shoes; never use the treadmill with bare feet, wearing only stockings, or in sandals.*
10. When connecting the power cord (see page 13), plug the power cord into a surge suppressor (not included) and plug the surge suppressor into a grounded circuit capable of carrying 15 or more amps. No other appliance should be on the same circuit. Do not use an extension cord.
11. Use only a single-outlet surge suppressor that meets all of the specifications described on page 13. To purchase a surge suppressor call the telephone number on the front cover of this manual.
12. Failure to use a properly functioning surge suppressor could result in damage to the control system of the treadmill. If the control system is damaged, the walking belt may slow, accelerate, or stop unexpectedly, which may result in a fall and serious injury.
13. Keep the power cord and the surge suppressor away from heated surfaces.
14. Never move the walking belt while the power is turned off. Do not operate the treadmill if the power cord or plug is damaged, or if the treadmill is not working properly. (See TROUBLESHOOTING on page 25 if the treadmill is not working properly.)
15. Read, understand, and test the emergency stop procedure before using the treadmill (see HOW TO TURN ON THE POWER on page 15).
16. Never start the treadmill while you are standing on the walking belt. Always hold the handrails while using the treadmill.
17. The treadmill is capable of high speeds. Adjust the speed in small increments to avoid sudden jumps in speed.
18. The pulse sensor is not a medical device. Various factors, including the user's movement, may affect the accuracy of heart rate readings. The pulse sensor is intended only as an exercise aid in determining heart rate trends in general.

19. Never leave the treadmill unattended while it is running. Always remove the key, unplug the power cord, and switch the reset/off circuit breaker to the off position when the treadmill is not in use. (See the drawing on page 5 for the location of the circuit breaker.)
20. Do not attempt to raise, lower, or move the treadmill until it is properly assembled. (See ASSEMBLY on page 6, and HOW TO FOLD AND MOVE THE TREADMILL on page 23.) You must be able to safely lift 45 lbs. (20 kg) to raise, lower, or move the treadmill.
21. When folding or moving the treadmill, make sure that the storage latch is holding the frame securely in the storage position.
22. Never insert any object into any opening on the treadmill.
23. Inspect and properly tighten all parts of the treadmill regularly.
24. **DANGER:** Always unplug the power cord immediately after use, before cleaning the treadmill, and before performing the maintenance and adjustment procedures described in this manual. Never remove the motor hood unless instructed to do so by an authorized service representative. Servicing other than the procedures in this manual should be performed by an authorized service representative only.
25. This treadmill is intended for in-home use only. Do not use this treadmill in a commercial, rental, or institutional setting.
26. Over exercising may result in serious injury or death. If you feel faint or if you experience pain while exercising, stop immediately and cool down.

**SAVE THESE INSTRUCTIONS**

# BEFORE YOU BEGIN

Thank you for selecting the new PROFORM® 7.0 PERSONAL FITNESS TRAINER treadmill with Universal Dock for iPod®. The 7.0 PERSONAL FITNESS TRAINER treadmill with Universal Dock for iPod offers a selection of features designed to make your workouts at home more effective and enjoyable. And when you're not exercising, the treadmill can be folded up, requiring less than half the floor space of other treadmills.

ing this manual, please see the front cover of this manual. To help us assist you, note the product model number and serial number before contacting us. The model number and the location of the serial number decal are shown on the front cover of this manual.



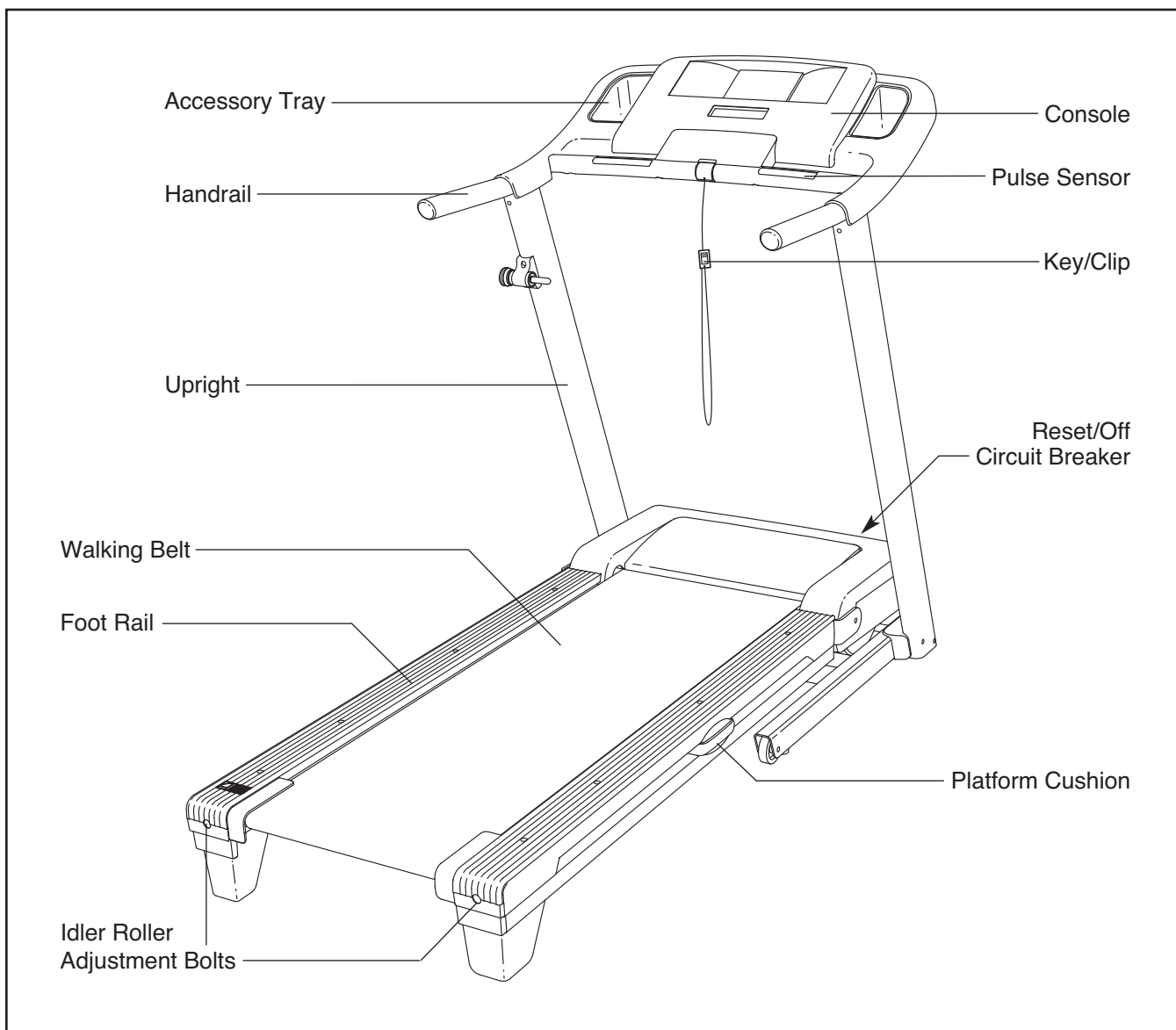

Before reading further, please review the drawing below and familiarize yourself with the labeled parts.

**For your benefit, read this manual carefully before using the treadmill.** If you have questions after read-

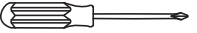

# ASSEMBLY

**Assembly requires two persons.** Set the treadmill in a cleared area and remove all packing materials. **Do not dispose of the packing materials until assembly is completed.** Note: The underside of the treadmill walking belt is coated with high-performance lubricant. During shipping, some lubricant may be transferred to the top of the walking belt or the shipping carton. This is normal and does not affect treadmill performance. If there is lubricant on top of the walking belt, simply wipe off the lubricant with a soft cloth and a mild, non-abrasive cleaner.

**Assembly requires the included hex keys  and your own Phillips screwdriver , adjustable wrench , scissors , and needlenose pliers .**

Use the drawings below to identify the assembly hardware. The number in parentheses below each drawing is the key number of the part, from the PART LIST near the end of this manual. The number after the parentheses is the quantity needed for assembly. **Note: If a part is not in the hardware kit, check to see if it is preattached to one of the parts to be assembled. Extra hardware may be included. To avoid damaging plastic parts, do not use power tools for assembly.**

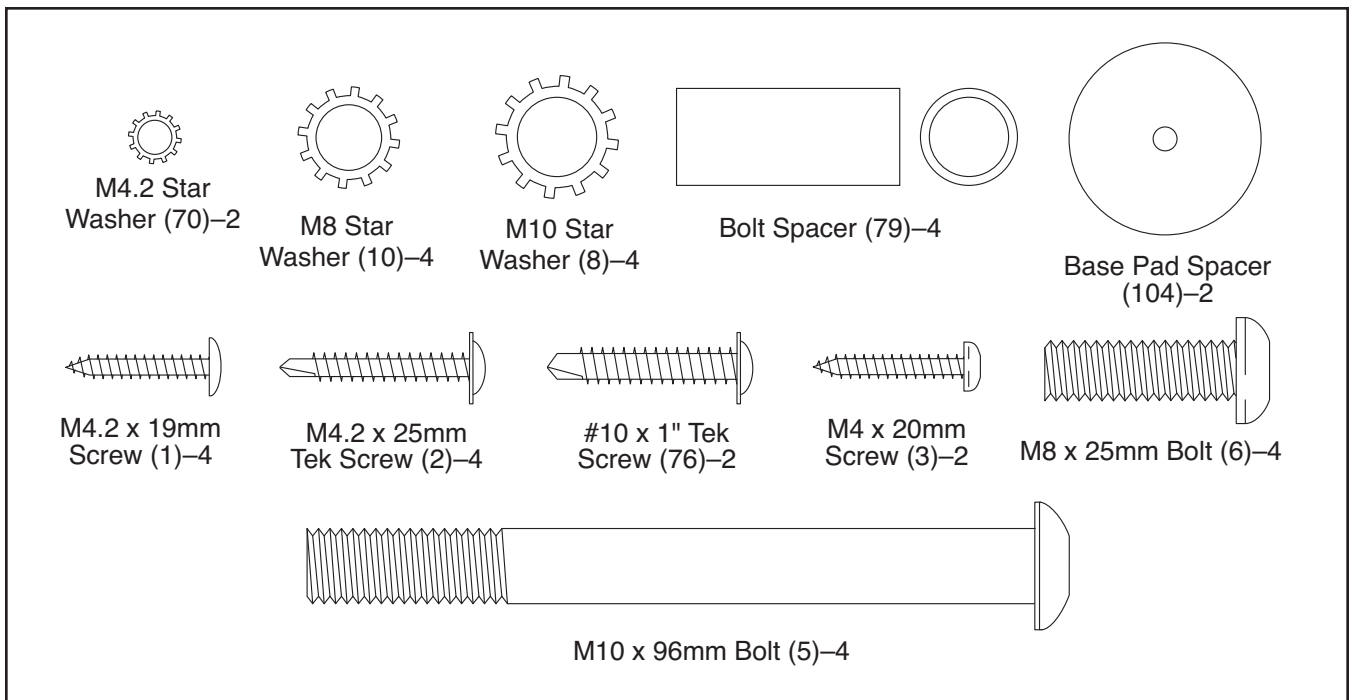

1. **Make sure that the power cord is unplugged.**

With the help of a second person, carefully tip the treadmill onto its left side. Partially fold the Frame (48) so that the treadmill is more stable; **do not fully fold the Frame yet.**

Remove and discard the two indicated bolts (A) and the shipping bracket (B).

Cut the tie securing the Upright Wire (77) to the Base (85). Locate the tie in the indicated hole in the Base, and use the tie to pull the Upright Wire out of the hole.

Attach a Base Pad (81) to the Base (85) in the location shown with a Base Pad Spacer (104) and an M4.2 x 25mm Tek Screw (2). Then, attach a Base Pad (81) in the location shown with only an M4.2 x 25mm Tek Screw (2).

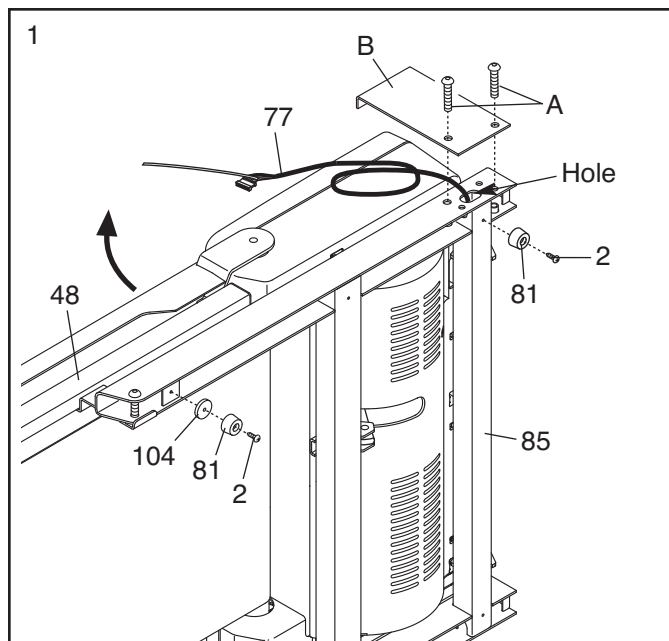

2. Remove the M10 Nut (33), the M10 x 50mm Bolt (4), and the shipping bracket (C) from the Base (85). Attach a Wheel (86) with the Bolt and the Nut that you just removed. **Do not overtighten the Nut; the Wheel must turn freely.** Discard the shipping bracket.

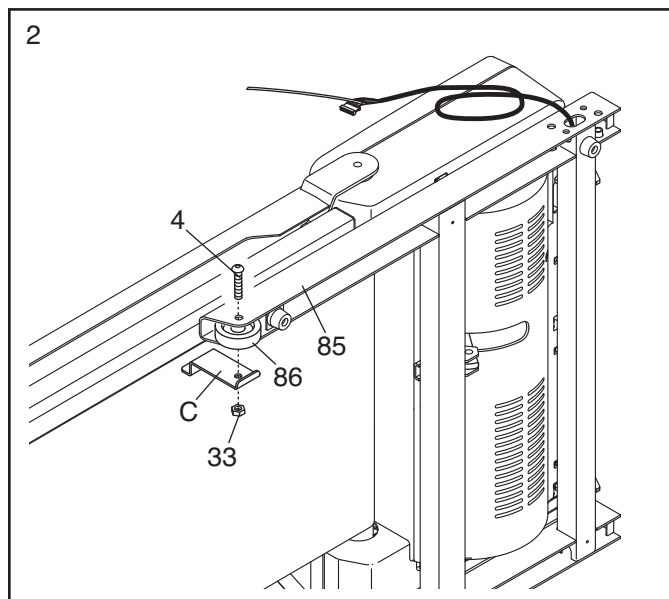

3. Identify the Right Upright (78) and the Right Upright Spacer (80), which are marked with "Right" stickers. Insert the Upright Wire (77) through the Right Upright Spacer as shown. Set the Right Upright Spacer on the Base (85).

Have a second person hold the Right Upright (78) near the Base (85). **See the inset drawing.** Tie the wire tie in the Right Upright securely around the end of the Upright Wire (77). Then, pull the other end of the wire tie until the Upright Wire is routed completely through the Right Upright.

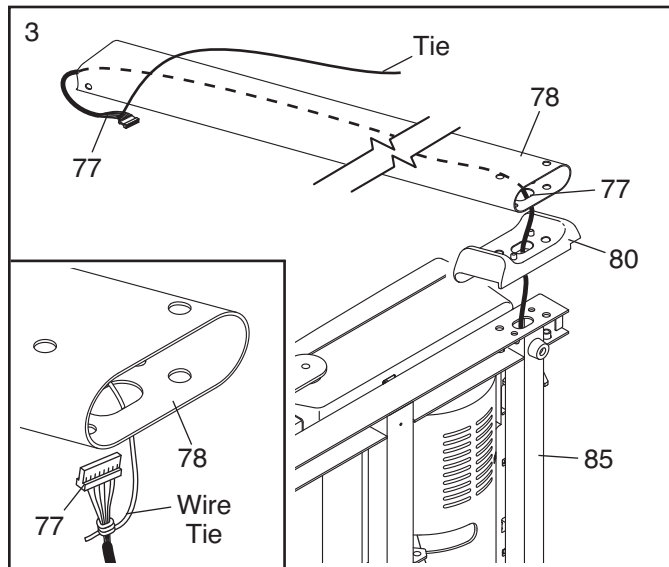

4. Hold a Bolt Spacer (79) inside the lower end of the Right Upright (78). Insert an M10 x 96mm Bolt (5) with an M10 Star Washer (8) into the Right Upright and the Bolt Spacer. **Repeat this step with a second Bolt Spacer (79), M10 x 96mm Bolt (5), and M10 Star Washer (8).**

Hold the Right Upright (78) against the Right Upright Spacer (80). **Be careful not to pinch the Upright Wire (77).** Partially tighten the M10 x 96mm Bolts (5); **do not fully tighten the Bolts yet.**

Press a Base Endcap (82) into the Base (85).

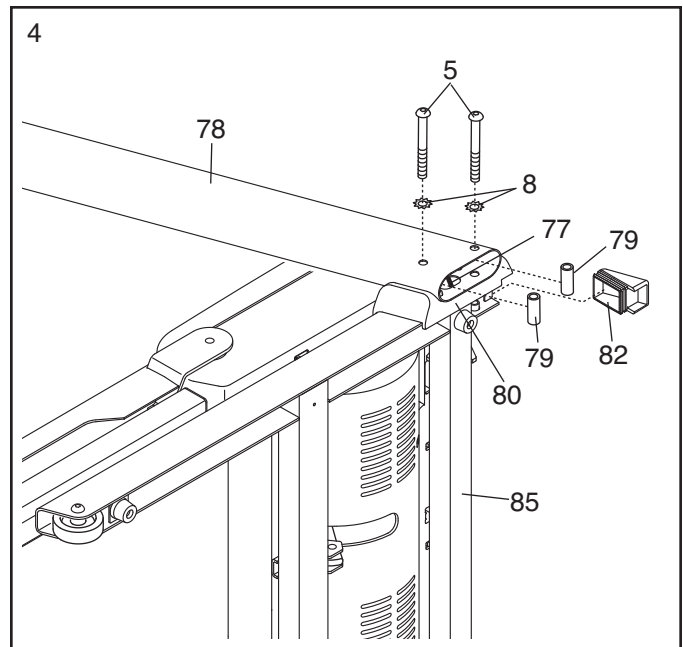

5. With the help of a second person, carefully tip the treadmill onto its right side. Partially fold the Frame (48) so the treadmill is more stable; **do not fully fold the Frame yet.**

Remove and discard the two indicated bolts (A) and the shipping bracket (B).

Attach a Base Pad (81) to the Base (85) in the location shown with a Base Pad Spacer (104) and an M4.2 x 25mm Tek Screw (2). Then, attach a Base Pad (81) in the location shown with only an M4.2 x 25mm Tek Screw (2).

Remove the M10 Nut (33), the M10 x 50mm Bolt (4), and the shipping bracket (C) from the Base (85). Attach a Wheel (86) with the Bolt and the Nut that you just removed. **Do not over-tighten the Nut; the Wheel must turn freely.** Discard the shipping bracket.

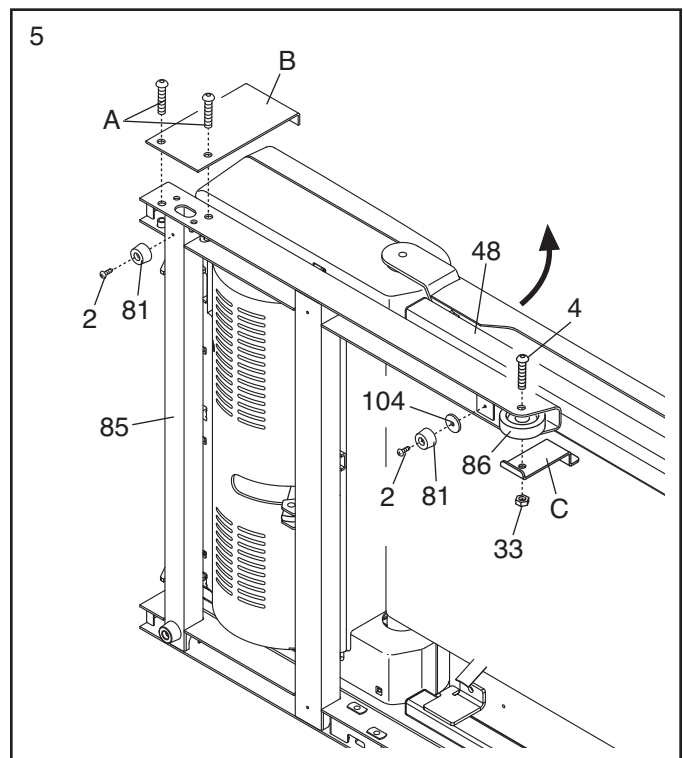



6. With the help of a second person, hold a Bolt Spacer (79) inside the lower end of the Left Upright (73). Insert an M10 x 96mm Bolt (5) with an M10 Star Washer (8) into the Left Upright and the Bolt Spacer. **Repeat this step with a second Bolt Spacer (79), M10 x 96mm Bolt (5), and M10 Star Washer (8).**

Orient the Left Upright (73) and the Left Upright Spacer (83) as shown. Hold the Left Upright Spacer and the Left Upright against the Base (85). Partially tighten the M10 x 96mm Bolts (5); **do not fully tighten the Bolts yet.**

Press a Base Endcap (82) into the Base (85).

With the help of a second person, tip the treadmill so that the Base (85) is flat on the floor.

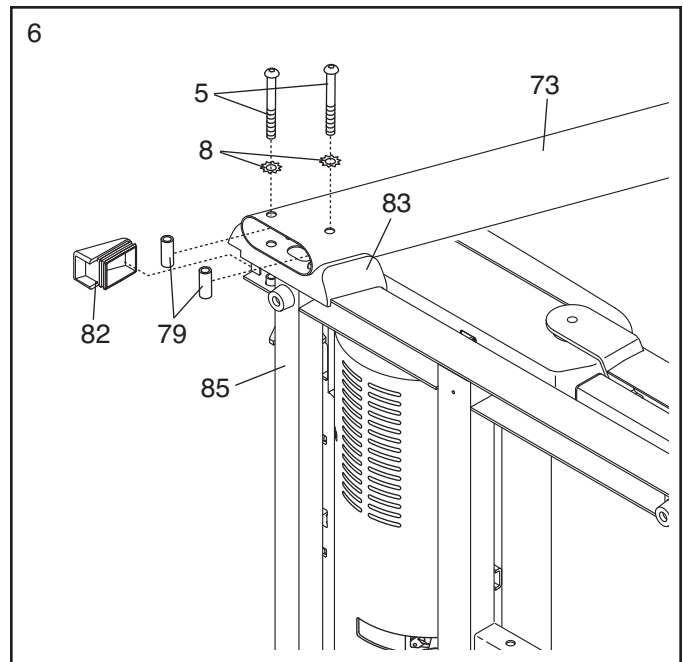

7. Set the console assembly face down on a soft surface to avoid scratching the console assembly. Remove the six M4.2 x 19mm Screws (1). **Save all six Screws for step 9.**

Lift off the Pulse Support (109).

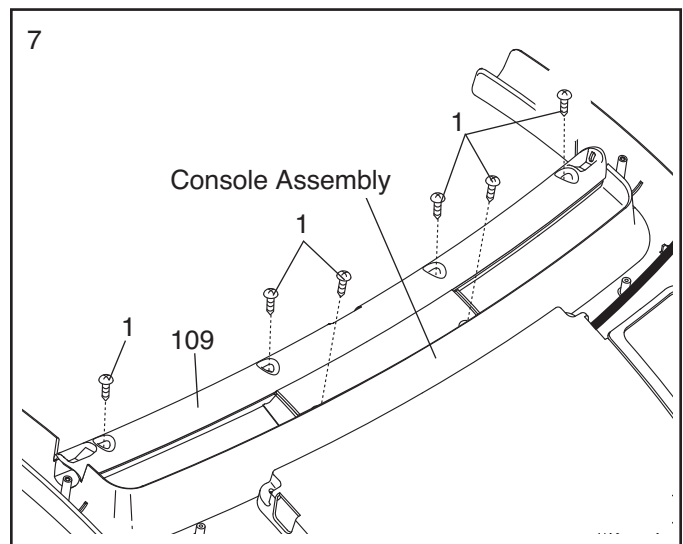

8. Identify the Right Handrail (90), which has a large hole in the location shown. Hold the Right Handrail near the console assembly.

Insert the tie on the console wire into the large hole in the Right Handrail (90) and out of the top as shown; use needlenose pliers if necessary. Next, insert the included plastic tie through the Right Handrail as shown. **Make sure that the plastic tie holds the console wire against the inner side.** Then, tighten the plastic tie.

Attach the Right Handrail (90) with two M4.2 x 19mm Screws (1). **Make sure that no wires are pinched. Start both Screws before tightening either of them; do not overtighten the Screws.** Then, remove the plastic tie.

**Attach the Left Handrail (not shown) to the console assembly in the same way.** Note: There are no wires on the left side of the console assembly.

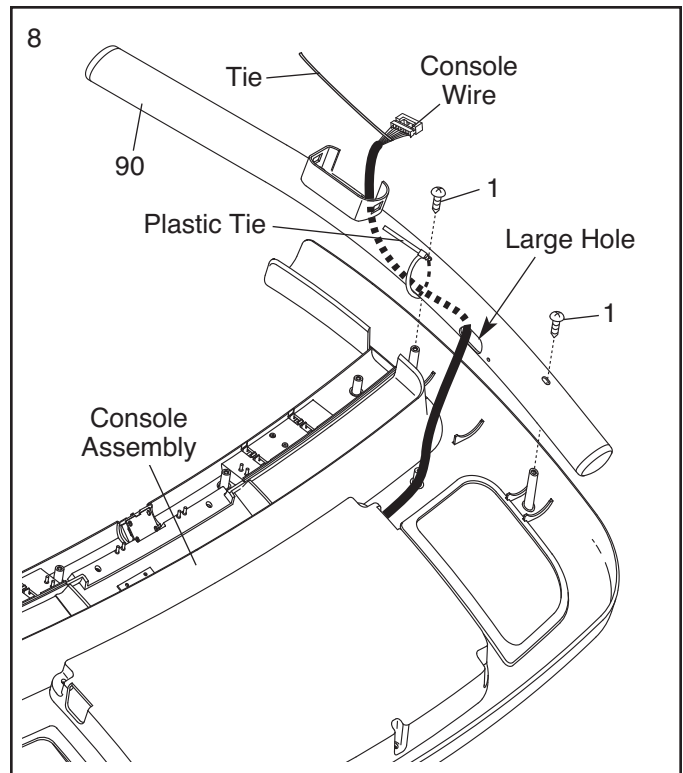

9. Hold the Pulse Support (109) near the console assembly. Connect the Console Ground Wire (40) on the Pulse Support to the ground wire on the console assembly. Then, insert the ground wires into the console assembly and set the Pulse Support on the console assembly. **Make sure that no wires are pinched.**

Tighten two M4 x 20mm Screws (3) with two M4.2 Star Washers (70) into the Pulse Support (109).

Tighten the six M4.2 x 19mm Screws (1) from step 7 into the Pulse Support (109) and the console assembly. **Start all six Screws before tightening any of them.**

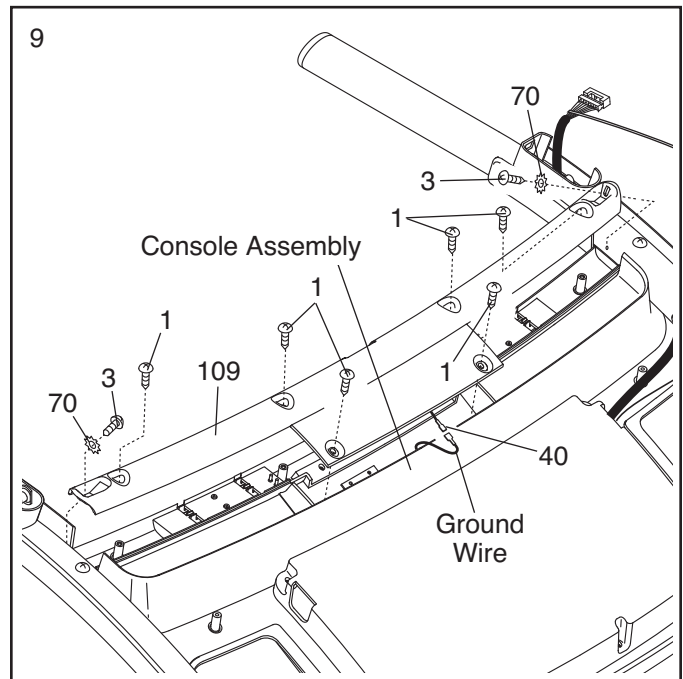

10. Remove the plastic ties from the Right Handrail (90) and the Left Handrail (not shown). If necessary, press the Cage Nuts (38) into place.

Have a second person hold the console assembly near the Right Upright (78). Remove the long tie from the Upright Wire (77) and the tie from the console wire.

Connect the Upright Wire (77) to the console wire. **See the inset drawing. The connectors should slide together easily and snap into place.** If they do not, turn one connector and try again. **IF THE CONNECTORS ARE NOT CONNECTED PROPERLY, THE CONSOLE MAY BE DAMAGED WHEN THE POWER IS TURNED ON.** Then, insert the connectors into the Right Upright (78).

Set the console assembly on the Right Upright (78) and the Left Upright (not shown). **Make sure that no wires are pinched.**

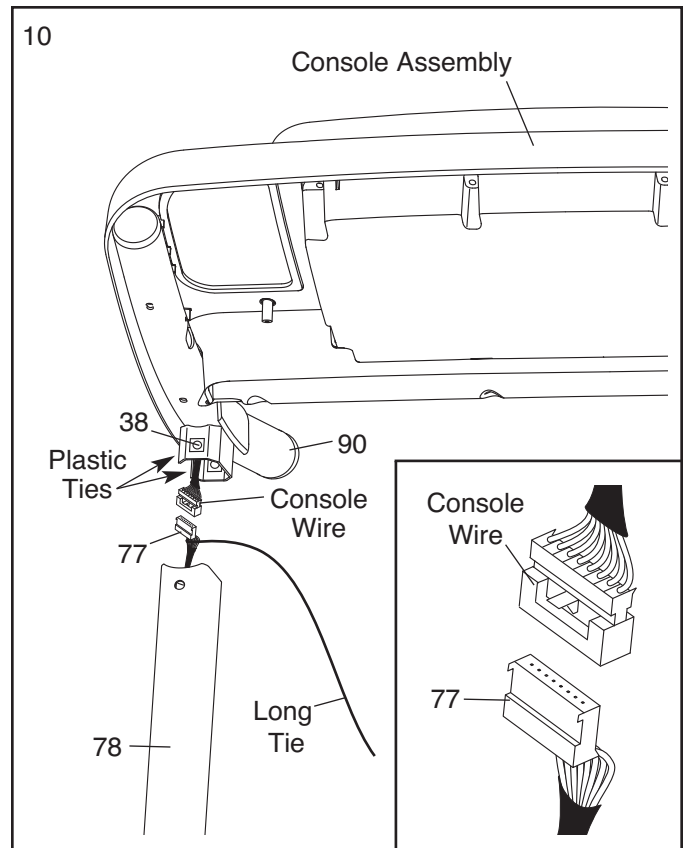

11. Partially tighten two M8 x 25mm Bolts (6) with two M8 Star Washers (10) into the Left Upright (73) and the Left Handrail (89).

Next, partially tighten two M8 x 25mm Bolts (6) with two M8 Star Washers (10) into the Right Upright (78) and the Right Handrail (90). **Then, tighten all four Bolts.**

**See steps 4 and 6.** Tighten the M10 x 96mm Bolts (5).

Press the Left Accessory Tray (110) and the Right Accessory Tray (111) into the console assembly.

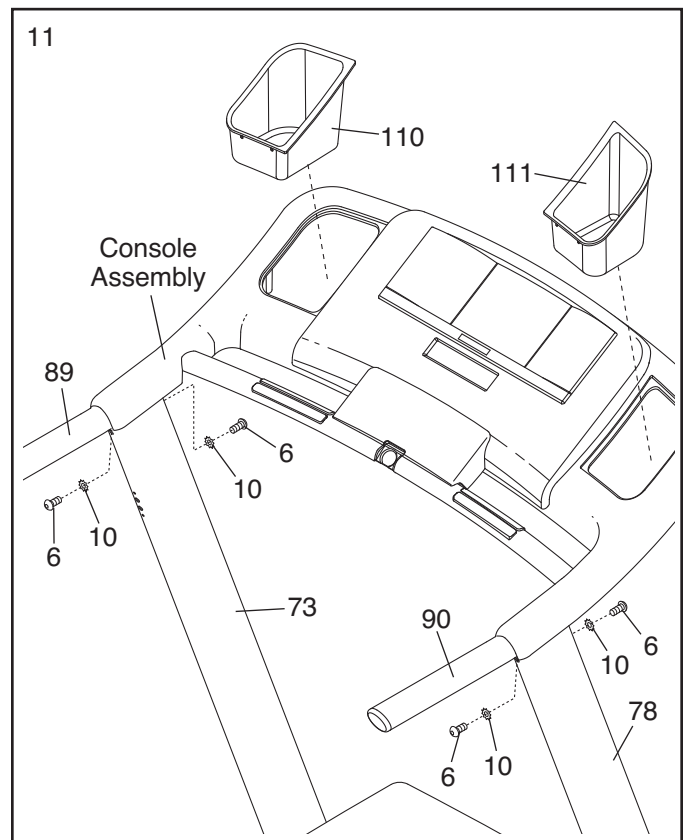

12. Attach the Latch Housing (71) to the Left Upright (73) with two #10 x 1" Tek Screws (76). **Make sure that the large hole in the Latch Housing is on the side shown. Do not overtighten the Latch Screws.**

Locate the Latch Pin Assembly (72). Remove the knob from the pin. Make sure that the collar and the spring are on the pin. Then, insert the pin into the Latch Housing (71), and tighten the knob back onto the pin.

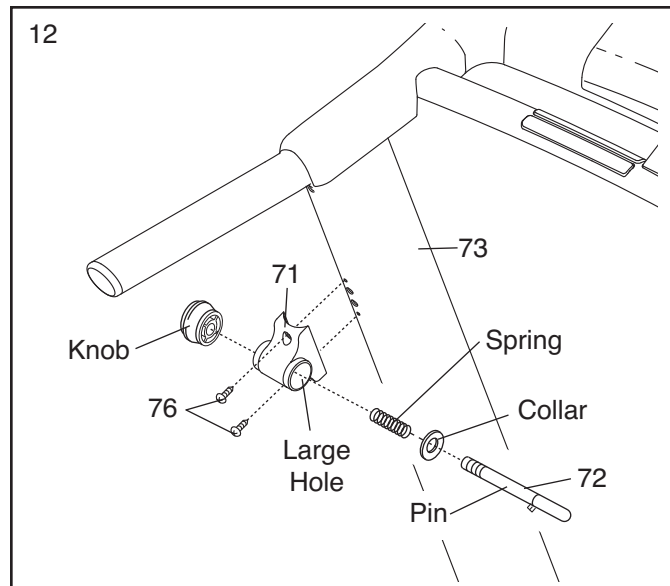

13. **Make sure that all parts are properly tightened before you use the treadmill.** If there are sheets of clear plastic on the treadmill decals, remove the plastic. To protect the floor or carpet, place a mat under the treadmill. Keep the included hex keys in a secure place; one of the hex keys is used to adjust the walking belt (see pages 26 and 27).

**If you purchase the optional chest pulse sensor (see page 22), follow the steps below to install the receiver included with the chest pulse sensor.**

1. **Make sure that the power cord is unplugged.** Remove the indicated M4.2 x 16mm Screw (12) and the Access Door (97) from the Console Base (88).
2. Connect the wire on the receiver to the indicated wire extending from the Console Base (88). **Hold the receiver so the small cylinder is oriented as shown and is facing the Console Base.** Attach the receiver to the plastic posts on the Access Door (97) with the two included small screws.
3. **Make sure that no wires are pinched.** Reattach the Access Door (97) with the M4.2 x 16mm Screw (12). Discard the other wires included with the receiver.

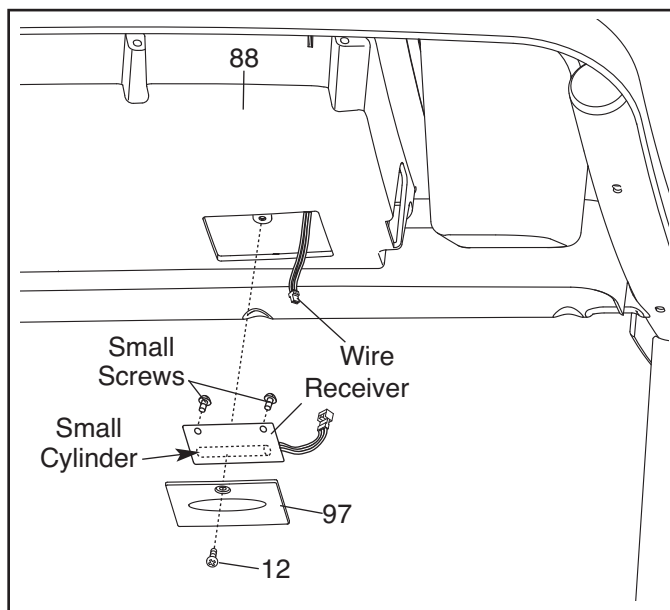

# OPERATION AND ADJUSTMENT

## THE PRE-LUBRICATED WALKING BELT

Your treadmill features a walking belt coated with high-performance lubricant. **IMPORTANT: Never apply silicone spray or other substances to the walking belt or the walking platform. Such substances will deteriorate the walking belt and cause excessive wear.**

## HOW TO PLUG IN THE POWER CORD

**⚠ DANGER:** Improper connection of the equipment-grounding conductor can result in an increased risk of electric shock. Check with a qualified electrician or serviceman if you are in doubt as to whether the product is properly grounded. Do not modify the plug provided with the product—if it will not fit the outlet, have a proper outlet installed by a qualified electrician.

Your treadmill, like any other type of sophisticated electronic equipment, can be seriously damaged by sudden voltage changes in your home's power. Voltage surges, spikes, and noise interference can result from weather conditions or from other appliances being turned on or off. **To decrease the possibility of your treadmill being damaged, always use a surge suppressor with your treadmill (see drawing 1 at the right). To purchase a surge suppressor call the telephone number on the front cover of this manual.**

Use only a single-outlet surge suppressor that is UL 1449 listed as a transient voltage surge suppressor (TVSS). The surge suppressor must have a UL suppressed voltage rating of 400 volts or less and a minimum surge dissipation of 450 joules. The surge suppressor must be electrically rated for 120 volts AC and 15 amps. There must be a monitoring light on the surge suppressor to indicate whether it is functioning properly. Failure to use a properly functioning surge suppressor could result in damage to the control system of the treadmill. If the control system is damaged, the walking belt may slow, accelerate, or stop unexpectedly, which may result in a fall and serious injury.

**This product must be grounded.** If it should malfunction or break down, grounding provides a path of least resistance for electric current to reduce the risk of electric shock. This product is equipped with a cord having

an equipment-grounding conductor and a grounding plug. **Plug the power cord into a surge suppressor, and plug the surge suppressor into an appropriate outlet that is properly installed and grounded in accordance with all local codes and ordinances. IMPORTANT: The treadmill is not compatible with GFCI-equipped outlets.**

This product is for use on a nominal 120-volt circuit, and has a grounding plug that looks like the plug illustrated in drawing 1 below. A temporary adapter that looks like the adapter illustrated in drawing 2 may be used to connect the surge suppressor to a 2-pole receptacle as shown in drawing 2 if a properly grounded outlet is not available.

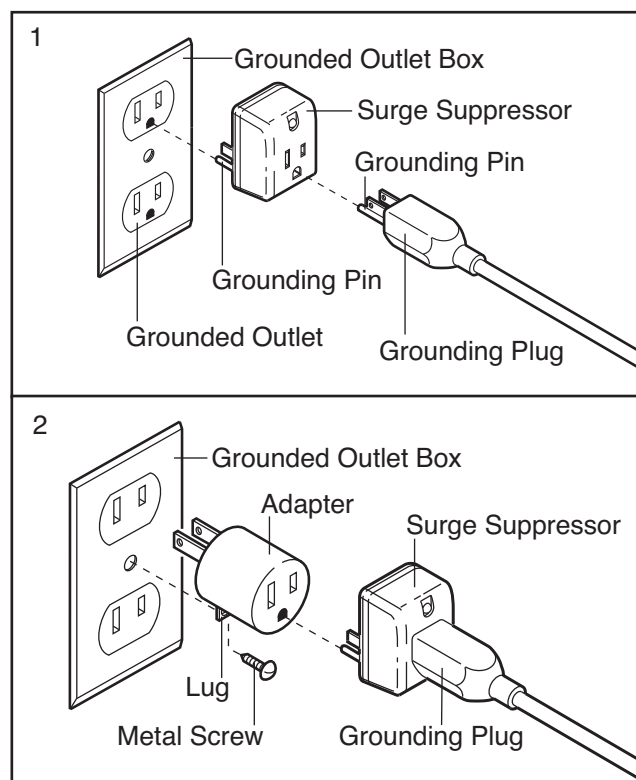

The temporary adapter should be used only until a properly grounded outlet (drawing 1) can be installed by a qualified electrician.

The green-colored rigid ear, lug, or the like extending from the adapter must be connected to a permanent ground such as a properly grounded outlet box cover. Whenever the adapter is used it must be held in place by a metal screw. **Some 2-pole receptacle outlet box covers are not grounded. Contact a qualified electrician to determine if the outlet box cover is grounded before using an adapter.**

## CONSOLE DIAGRAM

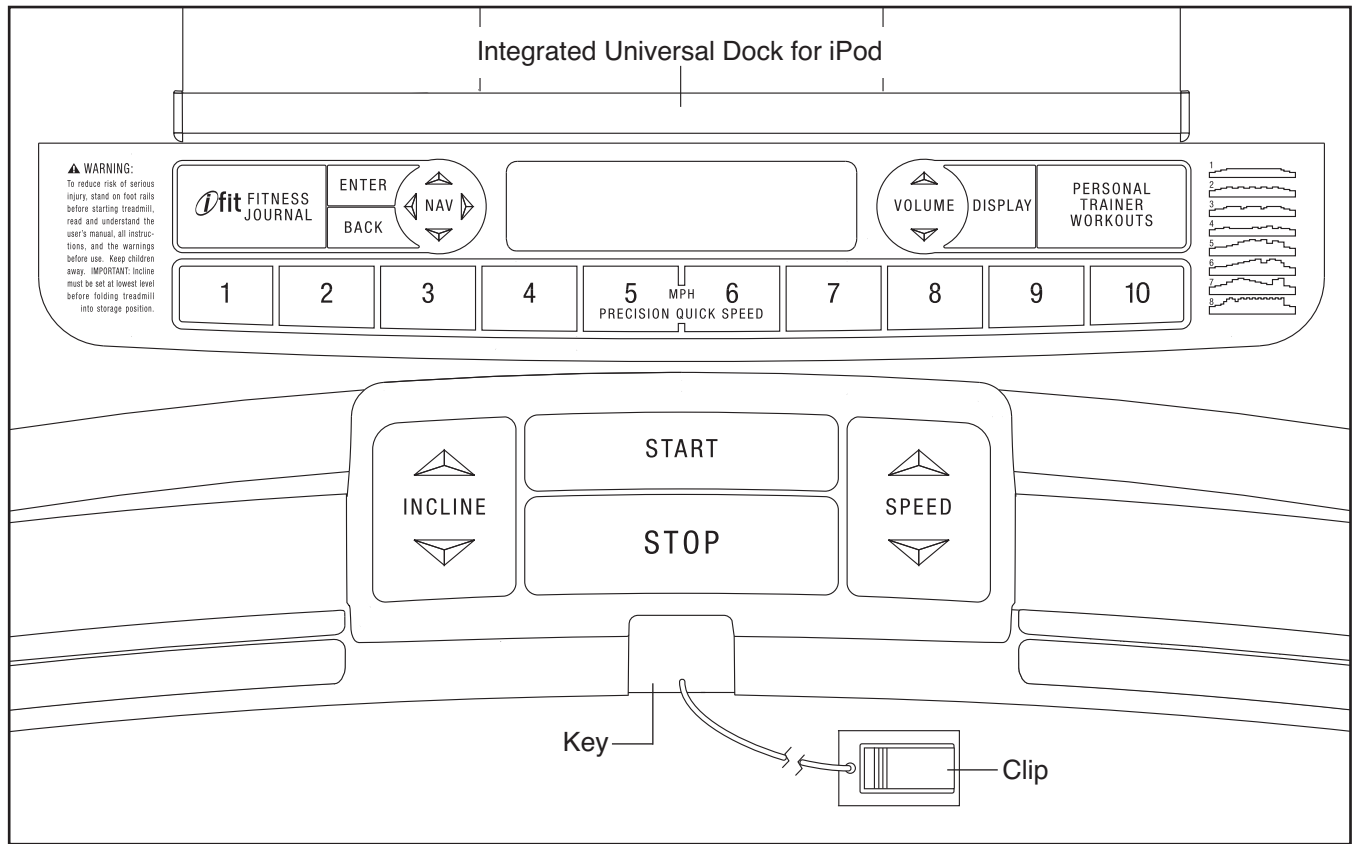

### FEATURES OF THE CONSOLE

The treadmill console offers an impressive array of features designed to make your workouts more effective and enjoyable.

When you use the manual mode, you can change the speed and incline of the treadmill with the touch of a button. As you exercise, the console will display instant exercise feedback. You can even measure your heart rate using the handgrip pulse sensor or the optional chest pulse sensor (see page 22).

In addition, the console features eight personal trainer workouts. Each workout automatically controls the speed and incline of the treadmill as it guides you through an effective exercise session.

The console also features a fitness journal, which automatically records and stores your exercise information so that you can view your workout history and track your progress.

You can even listen to your favorite workout music or audio books with the console's premium stereo sound system while you get in shape. This product has been designed specifically to work with iPod and has been

certified by the developer to meet Apple performance standards.

**To turn on the power**, see page 15. **To personalize the console settings**, see page 15. **To identify yourself as user 1 or user 2**, see page 17. **To use the manual mode**, see page 17. **To use a personal trainer workout**, see page 19. **To view the fitness journal**, see page 20. **To reset the fitness journal**, see page 21. **To use the stereo sound system**, see page 21. **To use the information mode**, see page 22.

**IMPORTANT: If there are sheets of clear plastic on the console, remove the plastic. To prevent damage to the walking platform, wear clean athletic shoes while using the treadmill. The first time you use the treadmill, observe the alignment of the walking belt, and center the walking belt if necessary (see page 27).**

Note: The console can display speed and distance in either miles or kilometers. To find out which unit of measurement is selected or to change the unit of measurement, see THE INFORMATION MODE on page 22. For simplicity, all instructions in this section refer to miles.

## HOW TO TURN ON THE POWER

**IMPORTANT:** If the treadmill has been exposed to cold temperatures, allow it to warm to room temperature before turning on the power. If you do not do this, you may damage the console displays or other electrical components.

Plug in the power cord (see page 13). Next, locate the reset/off circuit breaker on the treadmill frame near the power cord. Switch the circuit breaker to the reset position.

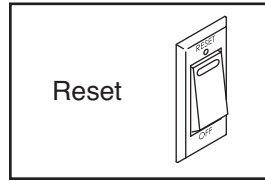

**IMPORTANT:** The console features a display demo mode, designed to be used if the treadmill is displayed in a store. If the display lights as soon as you plug in the power cord and switch the circuit breaker to the reset position, the demo mode is turned on. To turn off the demo mode, hold down the Stop button for a few seconds. If the display remains lit, see **THE INFORMATION MODE** on page 22 to turn off the demo mode.

Next, stand on the foot rails of the treadmill. Find the clip attached to the key (see the drawing on page 14) and slide the clip onto the waistband of your clothes. Then, insert the key into the console. After a moment, the display will light. **IMPORTANT:** In an emergency situation, the key can be pulled from the console, causing the walking belt to slow to a stop. Test the clip by carefully taking a few steps backward; if the key is not pulled from the console, adjust the position of the clip.

## HOW TO PERSONALIZE CONSOLE SETTINGS

The console has a user mode that allows you to designate yourself as User 1 or User 2, enter user information before you begin exercising, and select console settings. The user information you enter will also be recorded and stored in the fitness journal, which allows you to view your workout history (see **HOW TO VIEW THE FITNESS JOURNAL** on page 20).

Follow the steps below to personalize console settings.

### 1. Select the user mode.

The console can store information and keep track of workout history for two different users. To select the user mode, press the Enter button.

When you select the user mode, the word LOGIN will appear in the display for a few seconds and then the user mode menu will appear.

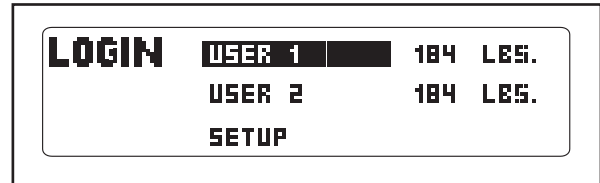

**Important:** To highlight options within a menu, press the up, down, left, or right Navigation (NAV) buttons. To select options within a menu, press the Enter button.

Note: To exit the user mode at any time, press the Back button repeatedly until the manual mode is selected (see step 2 on page 17). To re-enter the user mode from the manual mode, press the Enter button.

### 2. Enter user information.

To enter your user information, first highlight the SETUP option and press the Enter button. The setup menu will then appear in the display.

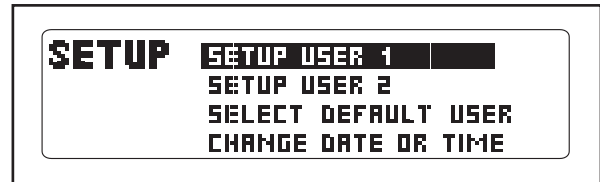

Next, highlight the SETUP USER 1 or SETUP USER 2 option and press the Enter button. The user information menu will then appear in the display.

You can now enter your name and your weight. Highlight the desired option in the menu and press the Enter button. A cursor will appear in a field in the display. To enter a number or letter above the cursor, press the up and down Navigation buttons. To move the cursor, press the left and right Navigation buttons. When you have finished entering the desired numbers or letters in the field, press the Enter button. Repeat this action to enter all the desired user information. Note: For more information about the RESET JOURNAL option, see page 21.



To exit the user information menu, highlight the SAVE AND EXIT option and press the Enter button.

### 3. Select a default user setting.

The console can record, store, and load information for two different users. The default user setting allows you to choose the user information that will be loaded and recorded when you turn on the console at the beginning of a workout session.

To select a default user setting, first highlight the SELECT DEFAULT USER option in the setup menu and press the Enter button. A list of default user options will then appear in the display.

To select a default user option, press the up and down Navigation buttons until an arrow appears next to the desired option. Then, press the Enter button. When you select an option, an "x" will appear in the box next to the selected option.

Note: You can also turn on or turn off the welcome screen from this menu. If the SHOW WELCOME SCREEN option is selected, then a welcome message with the name of the selected user will appear in the display each time you turn on the console. To turn on or turn off the welcome screen, highlight the SHOW WELCOME SCREEN option and press the Enter button.

To exit the default user menu, press the Back button. The setup menu will then appear in the display.

### 4. Set the date and time.

Setting the date and time will allow the console to record your workout history accurately in the fitness journal.

To set the date and time, first highlight the CHANGE DATE OR TIME option in the setup menu and press the Enter button. The date setting will then appear in the display.

To set the date, first press the left and right Navigation buttons to highlight the month, day, or year field. Then, press the up and down Navigation buttons to select the desired month, day, or year.

When you have finished setting the date, press the Enter button. The time setting will then appear in the display.

To set the time, first press the left and right Navigation buttons to select the hour or minute field. Then, press the up and down Navigation buttons to select the desired hour or minute; **make sure to select the correct AM or PM time in the hour field.** When you have finished setting the time, press the Enter button. The console will then exit the user mode.



## HOW TO IDENTIFY YOURSELF AS USER 1 OR USER 2

The console can load information and keep track of the workout history for two different users. To identify yourself as User 1 or User 2 for a workout session, first press the Enter button and enter the user mode.

The word LOGIN will appear in the display for a few seconds and then the user mode menu will appear. Press the up and down Navigation buttons to highlight USER 1 or USER 2. Note: If you have personalized the console settings (see page 15), then the name you entered will appear instead of USER 1 or USER 2.

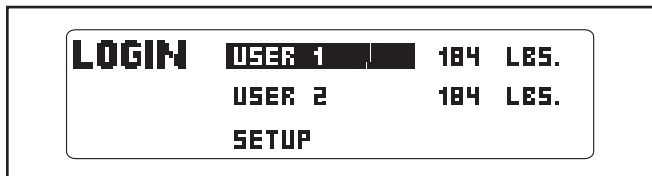

Press the Enter button to confirm your choice. The console will then exit the user mode.

## HOW TO USE THE MANUAL MODE

### 1. Insert the key into the console.

See HOW TO TURN ON THE POWER on page 15.

### 2. Select the manual mode.

When the key is inserted, the manual mode will be selected. If a personal trainer workout has been selected, remove the key and then reinsert it. Note: To turn on or turn off the welcome screen, see step 3 on page 16.

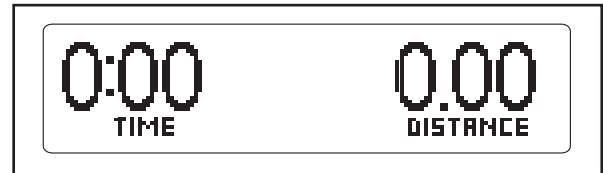

### 3. Start the walking belt.

To start the walking belt, press the Start button, the Speed increase button, or one of the Precision Quick Speed buttons numbered 1 through 10.

If you press the Start button or the Speed increase button, the walking belt will begin to move at 1 mph. As you exercise, change the speed of the walking belt as desired by pressing the Speed increase and decrease buttons. Each time you press a button, the speed setting will change by 0.1 mph; if you hold down a button, the speed setting will change in increments of 0.5 mph. Note: After you press a button, it may take a moment for the walking belt to reach the selected speed setting.

If you press one of the numbered Precision Quick Speed buttons, the walking belt will gradually change speed until it reaches the selected speed setting.

To stop the walking belt, press the Stop button. To restart the walking belt, press the Start button or the Speed increase button.

#### 4. Change the incline of the treadmill as desired.

To change the incline of the treadmill, press the Incline increase and decrease buttons. Each time you press the Incline increase and decrease button, the incline will change by 0.5%. Note: After you press an Incline button, it may take a moment for the treadmill to reach the selected incline setting.

#### 5. Select a display mode and monitor your progress with the display.

As you walk or run on the treadmill, the display can show the following workout information:

- The elapsed time.
- The distance that you have walked or run.
- The speed of the walking belt.
- The approximate number of calories you have burned.
- The date.
- A 1/4-mile (400 meter) track. As you walk or run, indicators will appear in succession around the track until the entire track appears. The track will then disappear and the indicators will again begin to appear in succession.
- The incline level of the treadmill.
- Your heart rate. Note: Your heart rate will be shown only when you use the handgrip pulse sensor or the optional chest pulse sensor (see step 6).
- An animation of a runner.

When the manual mode is selected, the console offers three display modes. Press the Display button repeatedly to select the desired display mode.

Regardless of which display mode you select, the speed or incline setting will appear in the display for a few seconds each time you change the setting. In addition, your heart rate will appear in the display each time you use the handgrip pulse sensor or the optional chest pulse sensor.

To reset the console, press the Stop button, remove the key, and then reinsert the key.

#### 6. Measure your heart rate if desired.

**Note: If you use the handgrip pulse sensor and the optional chest pulse sensor at the same time, the console will not display your heart rate accurately.** For information on the optional chest pulse sensor, see page 22.

Before using the handgrip pulse sensor, remove the sheets of clear plastic from the metal contacts on the pulse bar. In addition, make sure that your hands are clean.

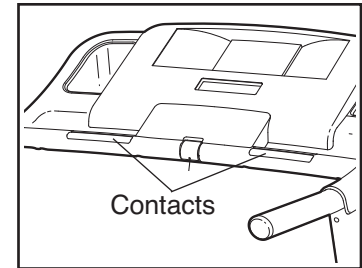

To measure your heart rate, **stand on the foot rails** and hold the pulse bar with your palms on the metal contacts. **Avoid moving your hands.** When your pulse is detected, a heart symbol will flash in the display and then your heart rate will be shown. **For the most accurate heart rate reading, continue to hold the contacts for about 15 seconds.**

#### 7. When you are finished exercising, remove the key from the console.

Step onto the foot rails, press the Stop button, and **adjust the incline of the treadmill to the lowest setting. The incline must be at the lowest setting or you may damage the treadmill when you fold it to the storage position.** Next, remove the key from the console and put it in a secure place.

When you are finished using the treadmill, switch the reset/off circuit breaker to the "off" position and unplug the power cord. **IMPORTANT: If you do not do this, the treadmill's electrical components may wear prematurely.**

## HOW TO USE A PERSONAL TRAINER WORKOUT

### 1. Insert the key into the console.

See HOW TO TURN ON THE POWER on page 15.

### 2. Select a personal trainer workout.

To select a personal trainer workout, press the Personal Trainer Workouts button repeatedly. The name, maximum incline setting, duration, and maximum speed setting of the workout will appear in the display. In addition, a profile of the speed settings of the workout will appear in the display.



### 3. Start the walking belt.

Press the Start button or the Speed increase button to start the workout. A moment after you press the button, the treadmill will automatically adjust to the first speed and incline settings of the workout. Hold the handrails and begin walking.

Each workout is divided into one-minute segments. One speed setting and one incline setting are programmed for each segment. Note: The same speed setting and/or incline setting may be programmed for consecutive segments.

A profile of the speed settings of the workout will appear in the display. A small arrow below the profile will indicate your progress.

At the end of the first one-minute segment of the workout, a series of tones will sound. If a different speed setting and/or incline setting is programmed for the second segment, the speed setting and/or incline setting will flash in the display for a moment to alert you. The treadmill will then automatically adjust to the speed and incline settings for the second segment and the arrow will move one segment to the right.

The workout will continue in this way until the arrow reaches the right end of the profile. The walking belt will then slow to a stop.

If the speed or incline setting for the current segment is too high or too low, you can override the setting by pressing the Speed or Incline buttons; **however, when the next segment begins, the treadmill will automatically adjust to the speed and incline settings for the next segment.**

To stop the workout at any time, press the Stop button. To restart the workout, press the Start button. The walking belt will begin to move at 1 mph. When the next segment of the workout begins, the treadmill will automatically adjust to the speed and incline settings for the next segment.

### 4. Select a display mode and monitor your progress with the display.

See step 5 on page 18.

### 5. Measure your heart rate if desired.

See step 6 on page 18.

### 6. When you are finished exercising, remove the key from the console.

See step 7 on page 18.

## HOW TO VIEW THE FITNESS JOURNAL

### 1. Insert the key into the console.

See HOW TO TURN ON THE POWER on page 15.

### 2. Identify yourself as User 1 or User 2.

See page 17.

### 3. Select the fitness journal.

To select the fitness journal, press the iFit Fitness Journal button. The console will then load the stored journal information for the selected user.

To enter the date and time, see page 16.

Note: As you view the fitness journal, press the Back button at any time to return to the previous menu or display.

The fitness journal can display the following exercise information for the current year:

**Time**—The total number of hours you have walked or run on the treadmill.

**Distance**—The total distance you have walked or run on the treadmill.

**Calories**—The approximate total number of calories you have burned.

**Average Speed**—Your average walking or running speed.

**Average Pace**—Your average walking or running pace in minutes per mile or per kilometer.

**Vertical Feet**—The distance you have climbed in feet or meters.

**Weight**—Your weight, as entered in your user information. Note: Your weight will be displayed only when you view exercise information by day.

### 4. View exercise information by year.

When you select the fitness journal, the year totals will appear in the display.

2010 TOTALS			
TIME	102 HRS.	AVG. SPEED	4.5 MPH
DISTANCE	87	AVG. PACE	12:00
CALORIES	631080	VERTICAL FT.	63

To view exercise information for a different year, press the up and down Navigation buttons to change the year. Note: The fitness journal can store information for 11 different years.

### 5. View exercise information by month.

After several seconds, the view month menu will appear in the display.

To view exercise information by month, press the up and down Navigation buttons to highlight the desired month in the right side of the display. Then, press the Enter button. The exercise information for the selected month will appear in the display.

### 6. View exercise information by week.

After several seconds, the view week menu will appear in the display.

To view exercise information by week, press the up and down Navigation buttons to highlight the desired week in the right side of the display. Then, press the Enter button. The exercise information for the selected week will appear in the display.

### 7. View exercise information by day.

After several seconds, the view day menu will appear in the display.

To view exercise information by day, press the left and right Navigation buttons until an arrow appears above the desired day in the right side of the display. Then, press the Enter button. The exercise information for the selected day will appear in the display. Note: If you exercise more than once per day, all of the exercise information for that day will be combined.

### 8. Continue to view the fitness journal as desired.

Repeat steps 4 through 7 to view exercise information for the desired year, month, week, or day.

### 9. Exit the fitness journal.

Press the iFit Fitness Journal button to exit the fitness journal at any time.

Note: To delete the exercise information stored in the fitness journal, see HOW TO RESET THE FITNESS JOURNAL on page 21.

## HOW TO RESET THE FITNESS JOURNAL

### 1. Select the user mode.

See step 1 on page 15.

### 2. Reset the fitness journal.

To delete exercise information stored in the fitness journal, first highlight the SETUP option and then press the Enter button. The setup menu will then appear in the display.

Next, highlight the SETUP USER 1 or SETUP USER 2 option and press the Enter button. The user information menu will then appear in the display.

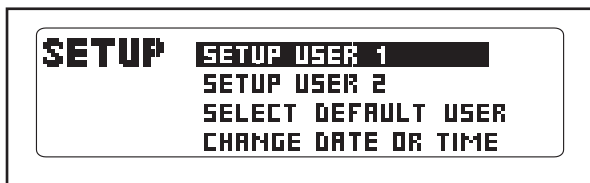

Then, highlight the RESET JOURNAL option and press the Enter button. A confirmation request will appear in the display. To delete the information stored in the fitness journal, use the left and right Navigation buttons to highlight the RESET JOURNAL option and press the Enter button. To retain the information stored in the fitness journal, highlight the CANCEL option and press the Enter button.



After you press the Enter button, the user information menu will again appear in the display.

### 3. Exit the user mode.

Press the Back button repeatedly until you have exited the user information menus.

## HOW TO USE THE STEREO SOUND SYSTEM

This product has been designed specifically to work with iPod and has been certified by the developer to meet Apple performance standards. To play music or audio books through the console's stereo speakers, you must connect your iPod, MP3 player, CD player, or other personal audio player to the console through the audio jack or through the Integrated Universal Dock for iPod. The Integrated Universal Dock for iPod will charge your iPod while you use it.

To use the audio jack, locate the audio wire and plug it into the audio jack near the speakers. Then, plug the audio wire into a jack on your MP3 player, CD player, or other personal audio player. **Make sure that the audio wire is fully plugged in.**

To use the Integrated Universal Dock for iPod, you need an iFIT Universal iPod Connector. Plug one end into the Integrated Universal Dock for iPod near the speakers and the other end into your iPod. **Make sure that the iFIT Universal iPod Connector is fully plugged in. To purchase an iFIT Universal iPod Connector, please call the telephone number on the front cover of this manual.**

Next, press the Play button on your iPod, MP3 player, CD player, or other personal audio player. Adjust the volume on your personal audio player or press the Volume increase and decrease buttons on the console.

If you are using a personal CD player and the CD skips, set the CD player on the floor or another flat surface instead of on the console.

## THE INFORMATION MODE

The console features an information mode that keeps track of the total distance that the walking belt has moved and the total number of hours that the treadmill has been used. The information mode also allows you to select a measurement system of miles or kilometers, to turn on and off the display demo mode, and to set the contrast of the display.

To select the information mode, hold down the Stop button while inserting the key into the console; when a tone sounds, release the Stop button. When the information mode is selected, the following information will be shown:

<b>TOTAL TIME</b>	<b>47</b>	<b>HOURS</b>
<b>TOTAL DISTANCE</b>	<b>98</b>	<b>MILES</b>
<b>UNITS</b>		<b>ENGLISH</b>
<b>DEMO MODE</b>		<b>OFF</b>
<b>LED CONTRAST</b>		<b>50</b>

The display will show the total number of hours the treadmill has been used.

The display will also show the total number of miles (or kilometers) that the walking belt has moved.

The word “English” for miles or “Metric” for kilometers will appear in the display. Press the Speed increase button to change the unit of measurement if desired.

Note: The console features a display demo mode, designed to be used if the treadmill is displayed in a store. While the demo mode is turned on, the console will function normally when you plug in the power cord, switch the reset/off circuit breaker to the reset position, and insert the key into the console. However, when you remove the key, the displays will remain lit, although the buttons will not function. If the demo mode is turned on, the word “On” will appear in the display while the information mode is selected. To turn on or off the demo mode, press the Speed decrease button.

The display will also show the contrast level of the display. Press the Incline increase and decrease buttons to adjust the contrast.

To exit the information mode, remove the key from the console.

## THE OPTIONAL CHEST PULSE SENSOR

An optional chest pulse sensor offers hands-free operation as it tracks your heart rate during your workouts.

**To purchase the optional chest pulse sensor, call the telephone number on the front cover of this manual.**

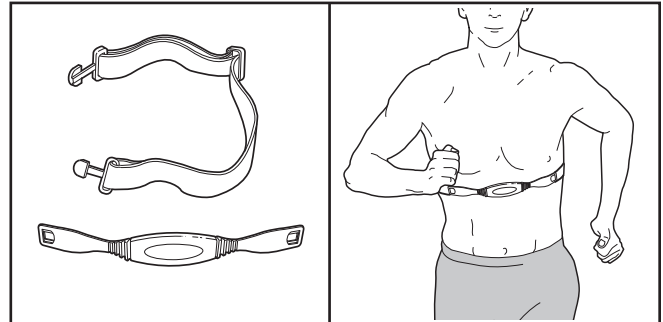

# HOW TO FOLD AND MOVE THE TREADMILL

## HOW TO FOLD THE TREADMILL FOR STORAGE

Before folding the treadmill, adjust the incline to the lowest position. If you do not do this, you may damage the treadmill when you fold it. Remove the key and unplug the power cord. **CAUTION:** You must be able to safely lift 45 lbs. (20 kg) to raise, lower, or move the treadmill.

1. Hold the metal frame firmly in the location shown by the arrow at the right. **CAUTION: To decrease the possibility of injury, do not lift the frame by the plastic foot rails. Make sure to bend your legs and keep your back straight as you raise the frame.** Raise the frame about halfway to the vertical position.
2. Move your right hand to the position shown and hold the treadmill firmly. Using your left hand, pull the latch knob to the left and hold it. Raise the frame until the latch pin is aligned with the gap between the frame and the walking platform, and then slowly release the latch knob. **Make sure that the latch pin is fully inserted into the gap.**

**To protect the floor or carpet from damage, place a mat under the treadmill. Keep the treadmill out of direct sunlight. Do not leave the treadmill in the storage position in temperatures above 85° F (30° C).**

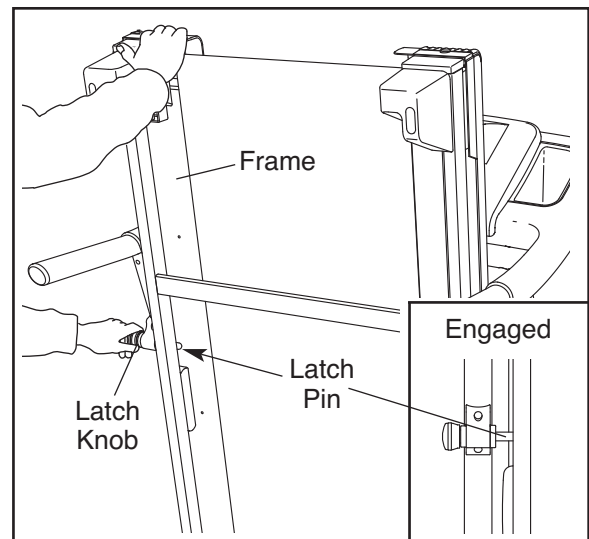
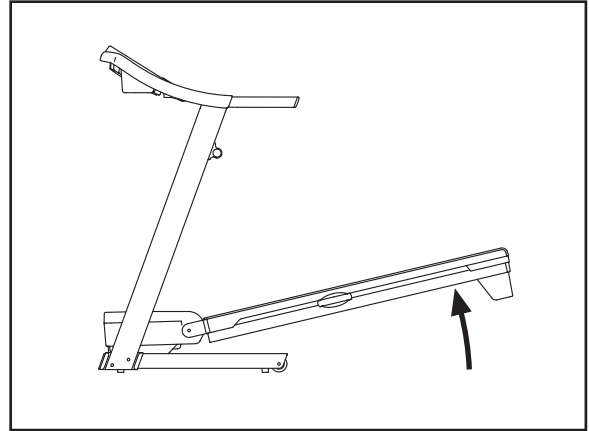

## HOW TO MOVE THE TREADMILL

Before moving the treadmill, convert it to the storage position as described above. **Make sure that the latch pin is fully inserted into the gap.**

1. Hold a handrail and the frame and place one foot against one of the wheels.
2. Tip the treadmill back until it rolls freely on the wheels. Carefully move the treadmill to the desired location. **Never move the treadmill without tipping it back. To reduce the risk of injury, use extreme caution while moving the treadmill. Do not attempt to move the treadmill over an uneven surface.**
3. Place one foot against a wheel, and carefully lower the treadmill until it is resting in the storage position.

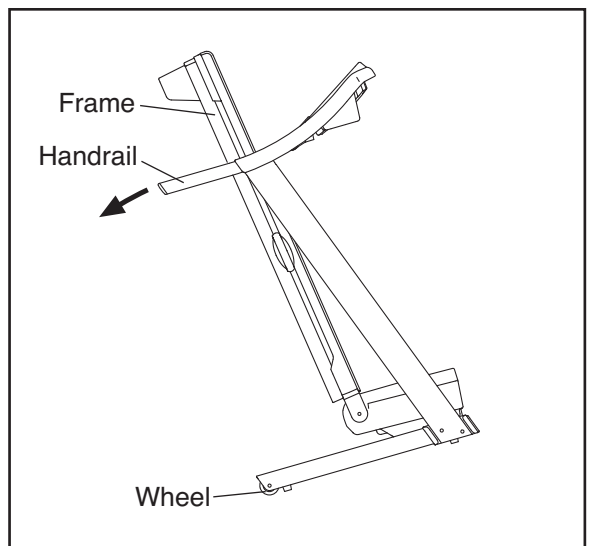

## HOW TO LOWER THE TREADMILL FOR USE

1. Hold the treadmill with your right hand. Pull the latch knob to the left and hold it. Pivot the frame downward until it is past the latch pin. Then, slowly release the latch knob.

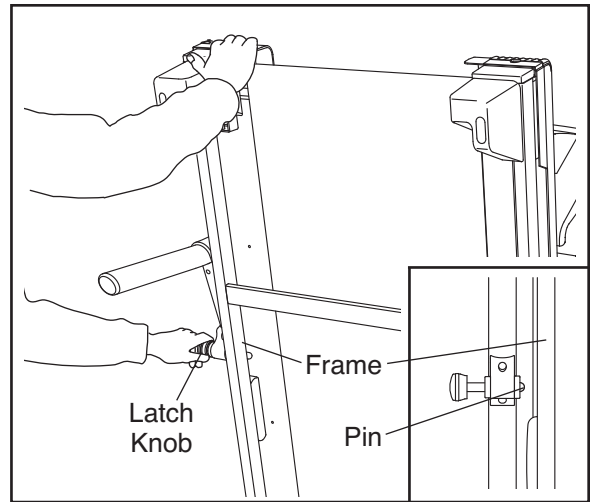

2. Hold the metal frame firmly with both hands and lower it to the floor. **CAUTION: Do not grip only the plastic foot rails or drop the frame to the floor. Bend your legs and keep your back straight.**

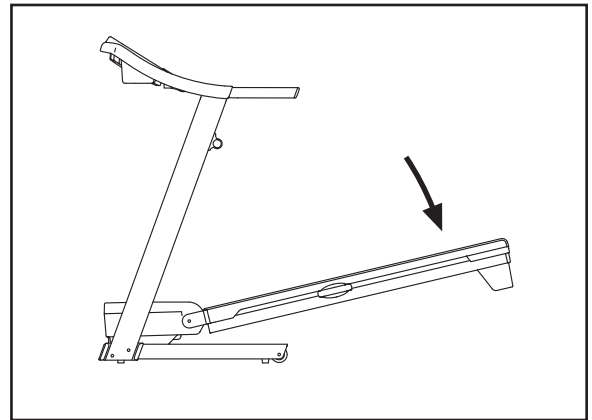



# TROUBLESHOOTING

Most treadmill problems can be solved by following the steps below. Find the symptom that applies, and follow the steps listed. If further assistance is needed, please see the front cover of this manual.

**PROBLEM: The power does not turn on**

**SOLUTION:** a. Make sure that the power cord is plugged into a surge suppressor, and that the surge suppressor is plugged into a properly grounded outlet (see page 13). Use only a single-outlet surge suppressor that meets all of the specifications described on page 13. **IMPORTANT: The treadmill is not compatible with GFCI-equipped outlets.**

b. After the power cord has been plugged in, make sure that the key is inserted into the console.

c. Check the reset/off circuit breaker located on the treadmill frame near the power cord. If the switch protrudes as shown, the circuit breaker has tripped. To reset the circuit breaker, wait for five minutes and then press the switch back in.

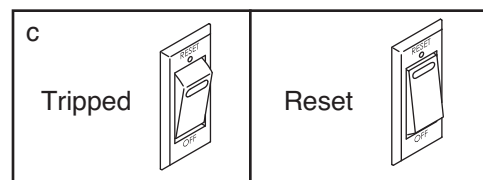

**PROBLEM: The power turns off during use**

**SOLUTION:** a. Check the reset/off circuit breaker (see the drawing above). If the circuit breaker has tripped, wait for five minutes and then press the switch back in.

b. Make sure that the power cord is plugged in. If the power cord is plugged in, unplug it, wait for five minutes, and then plug it back in.

c. Remove the key from the console. Reinsert the key into the console.

d. If the treadmill still will not run, please see the front cover of this manual.

**PROBLEM: The console displays remain lit when you remove the key from the console**

**SOLUTION:** a. The console features a display demo mode, designed to be used if the treadmill is displayed in a store. If the displays remain lit when you remove the key, the demo mode is turned on. To turn off the demo mode, hold down the Stop button for a few seconds. If the displays are still lit, see THE INFORMATION MODE on page 22 and turn off the demo mode.

**PROBLEM: The displays of the console do not function properly**

**SOLUTION:** a. Remove the key from the console and **UNPLUG THE POWER CORD**. With the help of a second person, carefully tip the Uprights (73, 78) down. There may be two Screws (A) in the bottom of the Belly Pan (69). If there are, remove them. Note: A Phillips screwdriver with a shaft at least 5 in. (13 cm) long is required.

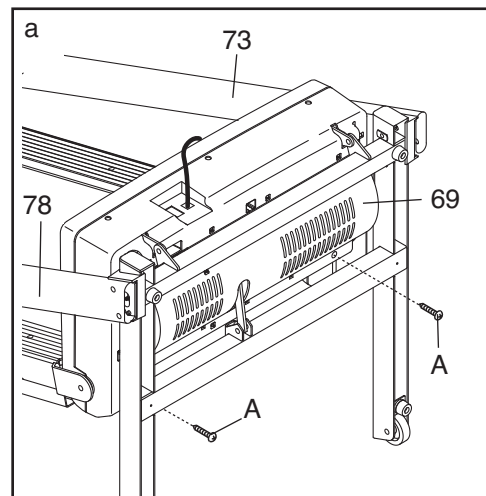

Remove the three M4.2 x 19mm Hood Screws (13) and carefully pivot the Hood (53) off.

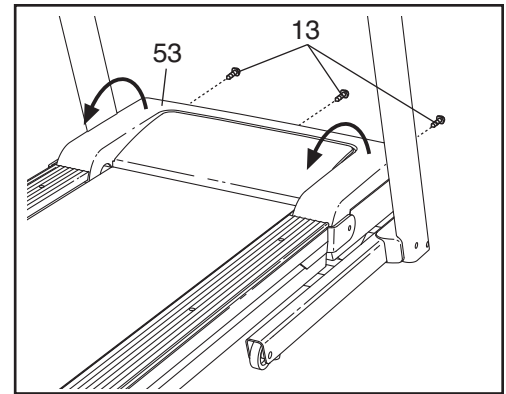

Locate the Reed Switch (54) and the Magnet (42) on the left side of the Pulley (44). Turn the Pulley until the Magnet is aligned with the Reed Switch. **Make sure that the gap between the Magnet and the Reed Switch is about 1/8 in. (3 mm).** If necessary, loosen the M4.2 x 19mm Screw (1), move the Reed Switch slightly, and then retighten the Screw. Reattach the Hood (not shown), and run the treadmill for a few minutes to check for a correct speed reading.

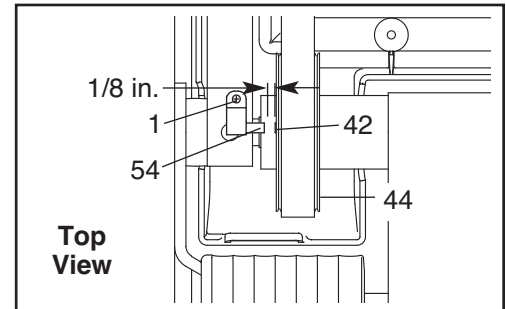

**PROBLEM: The incline of the treadmill does not change correctly**

**SOLUTION:** a. With the key in the console, press one of the Incline buttons. **While the incline is changing, remove the key.** After a few seconds, re-insert the key. The treadmill will automatically rise to the maximum incline level and then return to the minimum level. This will recalibrate the incline system.

**PROBLEM: The walking belt slows when walked on**

**SOLUTION:** a. Use only a single-outlet surge suppressor that meets all of the specifications described on page 13.

b. If the walking belt is overtightened, treadmill performance may decrease and the walking belt may become damaged. Remove the key and **UNPLUG THE POWER CORD.** Using the hex key, turn both idler roller bolts counterclockwise, 1/4 of a turn. When the walking belt is properly tightened, you should be able to lift each edge of the walking belt 2 to 3 in. (5 to 7 cm) off the walking platform. Be careful to keep the walking belt centered. Then, plug in the power cord, insert the key, and run the treadmill for a few minutes. Repeat until the walking belt is properly tightened.

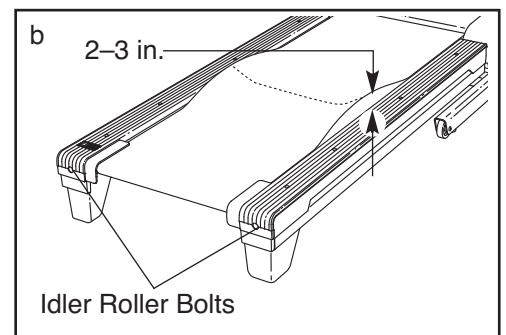

c. If the walking belt still slows when walked on, see the front cover of this manual.

**PROBLEM: The walking belt is off-center or slips when walked on**

**SOLUTION:** a. **If the walking belt is off-center**, first remove the key and **UNPLUG THE POWER CORD**. **If the walking belt has shifted to the left**, use the hex key to turn the left idler roller bolt clockwise 1/2 of a turn; **if the walking belt has shifted to the right**, turn the bolt counterclockwise 1/2 of a turn. Be careful not to overtighten the walking belt. Then, plug in the power cord, insert the key, and run the treadmill for a few minutes. Repeat until the walking belt is centered.

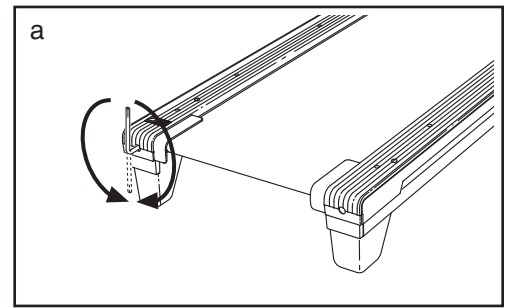

b. **If the walking belt slips when walked on**, first remove the key and **UNPLUG THE POWER CORD**. Using the hex key, turn both idler roller bolts clockwise, 1/4 of a turn. When the walking belt is correctly tightened, you should be able to lift each side of the walking belt 2 to 3 in. (5 to 7 cm) off the walking platform. Be careful to keep the walking belt centered. Then, plug in the power cord, insert the key, and carefully walk on the treadmill for a few minutes. Repeat until the walking belt is properly tightened.

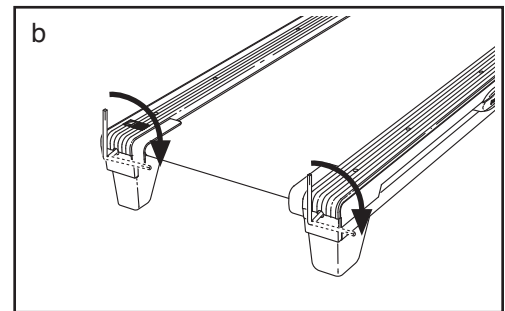

# EXERCISE GUIDELINES

**⚠️ WARNING:** Before beginning this or any exercise program, consult your physician. This is especially important for persons over age 35 or persons with pre-existing health problems.

The pulse sensor is not a medical device. Various factors may affect the accuracy of heart rate readings. The pulse sensor is intended only as an exercise aid in determining heart rate trends in general.

These guidelines will help you to plan your exercise program. For detailed exercise information, obtain a reputable book or consult your physician. Remember, proper nutrition and adequate rest are essential for successful results.

## EXERCISE INTENSITY

Whether your goal is to burn fat or to strengthen your cardiovascular system, exercising at the proper intensity is the key to achieving results. You can use your heart rate as a guide to find the proper intensity level. The chart below shows recommended heart rates for fat burning and aerobic exercise.

165	155	145	140	130	125	115	♥
145	138	130	125	118	110	103	♥
125	120	115	110	105	95	90	♥
<hr/>							
20	30	40	50	60	70	80	

To find the proper intensity level, find your age at the bottom of the chart (ages are rounded off to the nearest ten years). The three numbers listed above your age define your “training zone.” The lowest number is the heart rate for fat burning, the middle number is the heart rate for maximum fat burning, and the highest number is the heart rate for aerobic exercise.

**Burning Fat**—To burn fat effectively, you must exercise at a low intensity level for a sustained period of time. During the first few minutes of exercise, your body uses *carbohydrate calories* for energy. Only after the first few minutes of exercise does your body begin to use stored *fat calories* for energy. If your goal is to burn fat, adjust the intensity of your exercise until your heart rate is near the lowest number in your training zone. For maximum fat burning, exercise with your heart rate near the middle number in your training zone.

**Aerobic Exercise**—If your goal is to strengthen your cardiovascular system, you must perform aerobic exercise, which is activity that requires large amounts of oxygen for prolonged periods of time. For aerobic exercise, adjust the intensity of your exercise until your heart rate is near the highest number in your training zone.

## WORKOUT GUIDELINES

**Warming Up**—Start with 5 to 10 minutes of stretching and light exercise. A warm-up increases your body temperature, heart rate, and circulation in preparation for exercise.

**Training Zone Exercise**—Exercise for 20 to 30 minutes with your heart rate in your training zone. (During the first few weeks of your exercise program, do not keep your heart rate in your training zone for longer than 20 minutes.) Breathe regularly and deeply as you exercise—never hold your breath.

**Cooling Down**—Finish with 5 to 10 minutes of stretching. Stretching increases the flexibility of your muscles and helps to prevent post-exercise problems.

## EXERCISE FREQUENCY

To maintain or improve your condition, complete three workouts each week, with at least one day of rest between workouts. After a few months of regular exercise, you may complete up to five workouts each week, if desired. Remember, the key to success is to make exercise a regular and enjoyable part of your everyday life.

## SUGGESTED STRETCHES

The correct form for several basic stretches is shown at the right. Move slowly as you stretch—never bounce.

### 1. Toe Touch Stretch

Stand with your knees bent slightly and slowly bend forward from your hips. Allow your back and shoulders to relax as you reach down toward your toes as far as possible. Hold for 15 counts, then relax. Repeat 3 times. Stretches: Hamstrings, back of knees and back.

### 2. Hamstring Stretch

Sit with one leg extended. Bring the sole of the opposite foot toward you and rest it against the inner thigh of your extended leg. Reach toward your toes as far as possible. Hold for 15 counts, then relax. Repeat 3 times for each leg. Stretches: Hamstrings, lower back and groin.

### 3. Calf/Achilles Stretch

With one leg in front of the other, reach forward and place your hands against a wall. Keep your back leg straight and your back foot flat on the floor. Bend your front leg, lean forward and move your hips toward the wall. Hold for 15 counts, then relax. Repeat 3 times for each leg. To cause further stretching of the achilles tendons, bend your back leg as well. Stretches: Calves, achilles tendons and ankles.

### 4. Quadriceps Stretch

With one hand against a wall for balance, reach back and grasp one foot with your other hand. Bring your heel as close to your buttocks as possible. Hold for 15 counts, then relax. Repeat 3 times for each leg. Stretches: Quadriceps and hip muscles.

### 5. Inner Thigh Stretch

Sit with the soles of your feet together and your knees outward. Pull your feet toward your groin area as far as possible. Hold for 15 counts, then relax. Repeat 3 times. Stretches: Quadriceps and hip muscles.

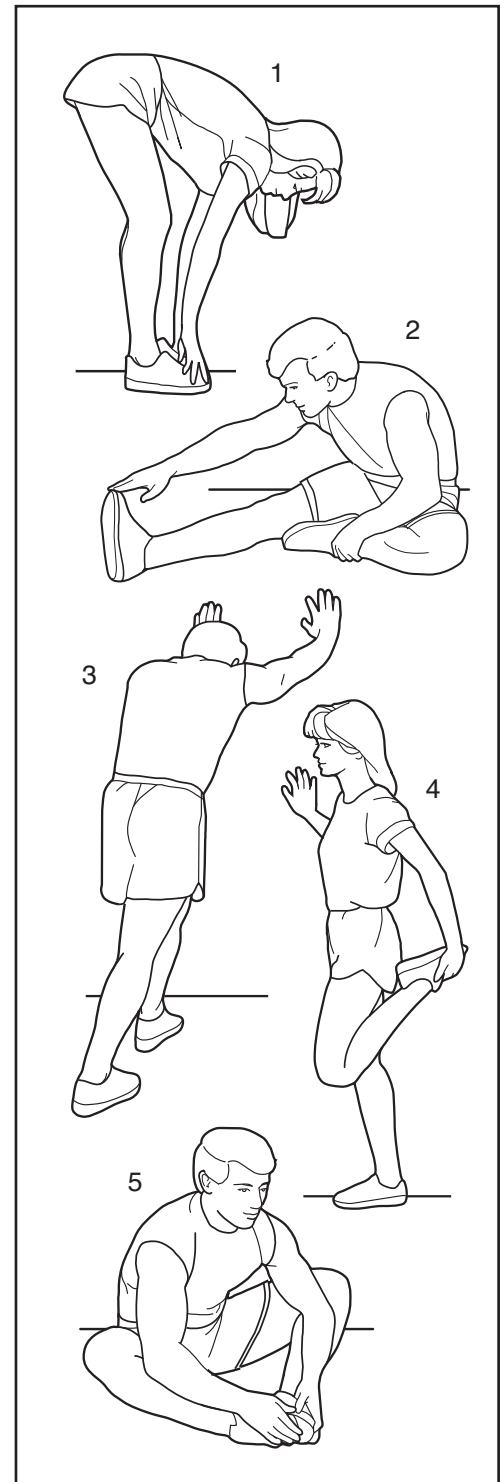

# PART LIST—Model No. PCTL57809.0

R0909A

To locate the parts listed below, see the EXPLODED DRAWING near the end of this manual.

Key No.	Qty.	Description	Key No.	Qty.	Description
1	19	M4.2 x 19mm Screw	51	1	Left Foot
2	4	M4.2 x 25mm Tek Screw	52	1	Right Foot
3	2	M4 x 20mm Screw	53	1	Hood
4	2	M10 x 50mm Bolt	54	1	Reed Switch
5	4	M10 x 96mm Bolt	55	1	Reed Switch Clip
6	4	M8 x 25mm Bolt	56	2	Frame Spacer
7	1	3/8" Star Washer	57	1	Frame/Roller Ground Wire
8	4	M10 Star Washer	58	1	Incline Motor
9	2	M8 Nut	59	2	Idler Roller Bracket
10	4	M8 Star Washer	60	1	Motor
11	5	M4.2 x 13mm Belly Pan Screw	61	1	Motor Bracket
12	13	M4.2 x 16mm Screw	62	3	Lift Frame Cable Tie
13	3	M4.2 x 19mm Hood Screw	63	1	Lift Frame
14	2	M8 x 35mm Screw	64	2	M8 Flange Nut
15	2	M8 x 90mm Screw	65	1	Power Cord
16	2	M10 x 30mm Bolt	66	1	Controller
17	2	M6 x 70mm Bolt	67	1	Power Cord Grommet
18	1	3/8" x 1 3/4" Bolt	68	1	Reset/Off Circuit Breaker
19	1	3/8" x 1 1/2" Bolt	69	1	Belly Pan
20	2	3/8" x 1" Bolt	70	2	M4.2 Star Washer
21	1	M6 x 45mm Bolt	71	1	Latch Housing
22	7	M4.2 x 13mm Ground Screw	72	1	Latch Pin Assembly
23	8	M5.5 x 25mm Screw	73	1	Left Upright
24	2	1/4" x 3/8" Bolt	74	1	Left Bottom Pulse Plate
25	2	3/8" x 3/4" Bolt	75	1	Audio Wire
26	1	3/8" x 4" Bolt	76	2	#10 x 1" Tek Screw
27	1	#8 x 1/2" Ground Screw	77	1	Upright Wire
28	4	M4.2 x 13mm Screw	78	1	Right Upright
29	2	M6 Lock Washer	79	4	Bolt Spacer
30	2	M6 Washer	80	1	Right Upright Spacer
31	3	3/8" Jam Nut	81	4	Base Pad
32	2	3/8" Motor Nut	82	2	Base Endcap
33	4	M10 Nut	83	1	Left Upright Spacer
34	1	6mm Hex Key	84	2	Caution Decal
35	2	Platform Cushion	85	1	Base
36	2	3/8" Locknut	86	2	Wheel
37	3	Hood Clip	87	1	Console
38	4	Cage Nut	88	1	Console Base
39	1	Left Foot Rail	89	1	Left Handrail
40	1	Console Ground Wire	90	1	Right Handrail
41	2	Belt Guide	91	2	Handrail Endcap, Lower
42	1	Magnet	92	2	Cable Tie
43	1	Motor Belt	93	1	Key/Clip
44	1	Drive Roller/Pulley	94	2	Releasable Tie
45	1	Walking Belt	95	10	8" Cable Tie
46	1	Walking Platform	96	1	Left Top Pulse Plate
47	1	Right Foot Rail	97	1	Access Door
48	1	Frame	98	1	15 1/2" Cable Tie
49	1	English Warning Decal	99	1	Lift Motor Spacer
50	2	Idler Roller Bracket Plate	100	1	Idler Roller

Key No.	Qty.	Description	Key No.	Qty.	Description
101	4	#3 x 1/4" Screw	112	2	Handrail Endcap, Upper
102	1	Lift Frame/Base Ground Wire	113	1	Right Bottom Pulse Plate
103	2	Frame Endcap	114	1	Right Top Pulse Plate
104	2	Base Pad Spacer	115	1	Key Plate
105	1	4mm Hex Key	116	1	French Warning Decal
106	1	5mm Hex Key	*	–	8" Blue Wire, 2F
107	4	Clamp	*	–	6" Blue Wire, M/F
108	1	Controller Ground Wire	*	–	6" Black Wire, M/F
109	1	Pulse Support	*	–	6" Red Wire, M/F
110	1	Left Accessory Tray	*	–	User's Manual
111	1	Right Accessory Tray			

Note: Specifications are subject to change without notice. For information about ordering replacement parts, see the back cover of this manual. \*These parts are not illustrated.

# EXPLODED DRAWING A—Model No. PCTL57809.0

R0909A

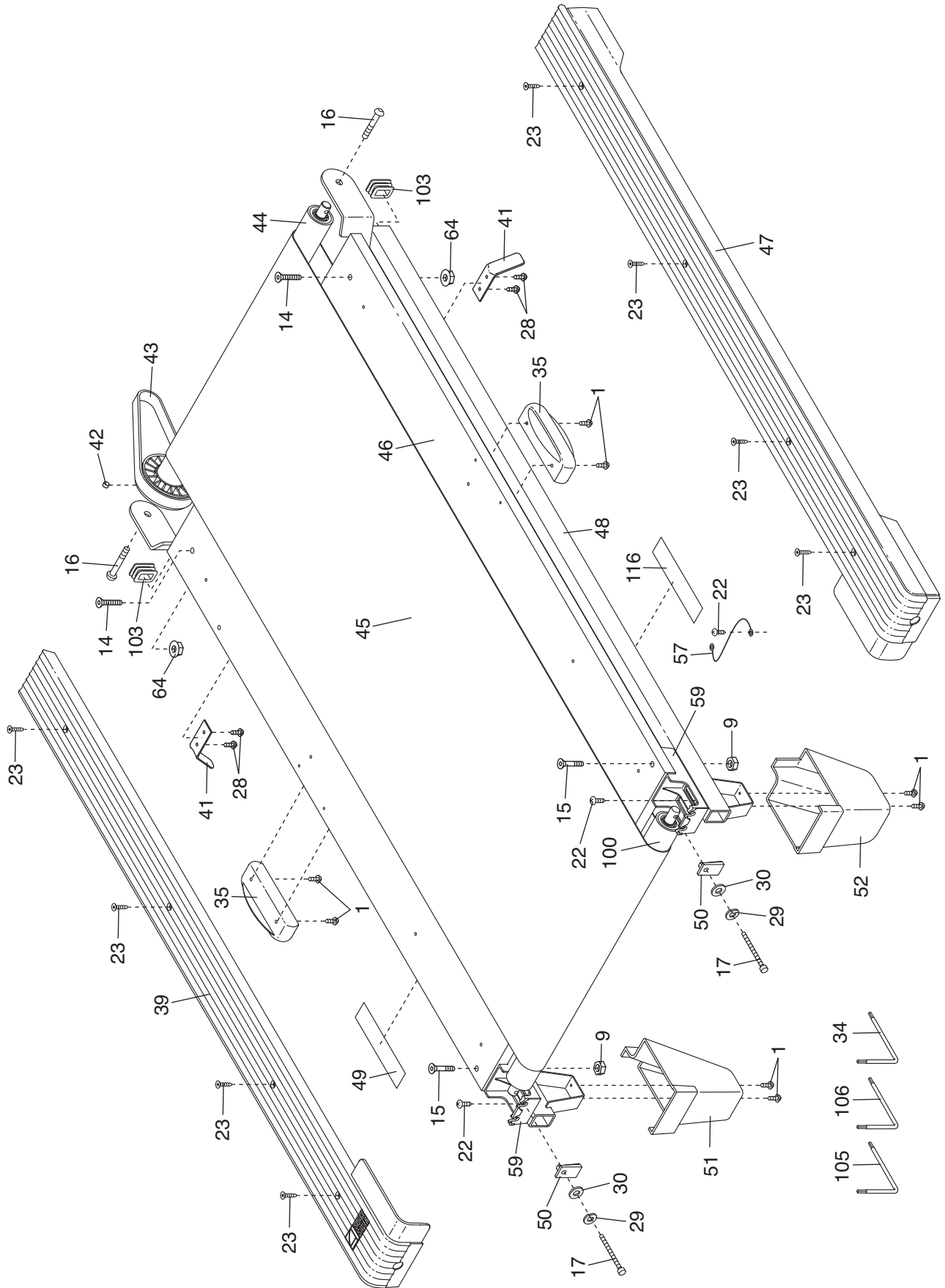



# EXPLODED DRAWING B—Model No. PCTL57809.0

R0909A

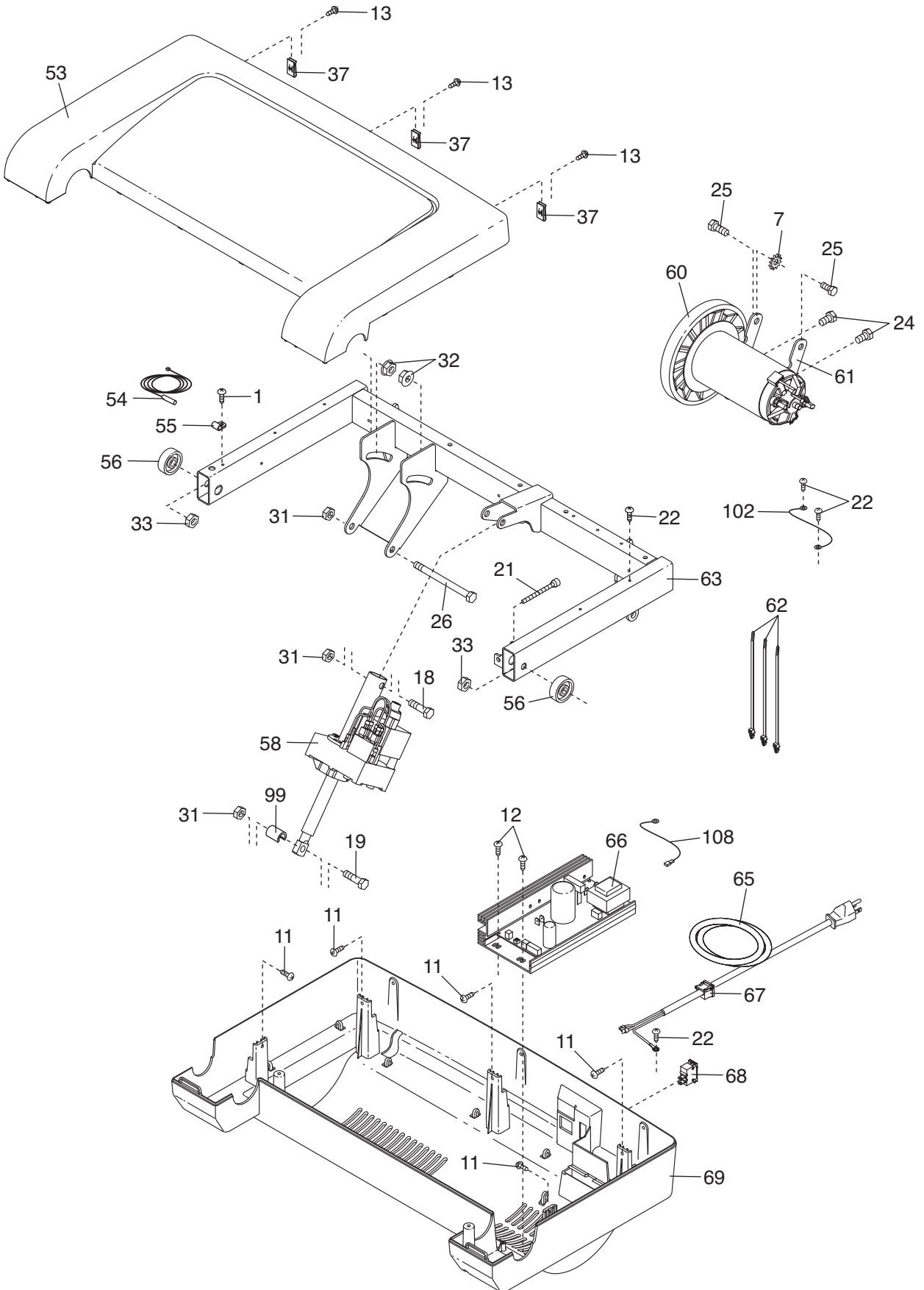

# EXPLODED DRAWING C—Model No. PCTL57809.0

R0909A

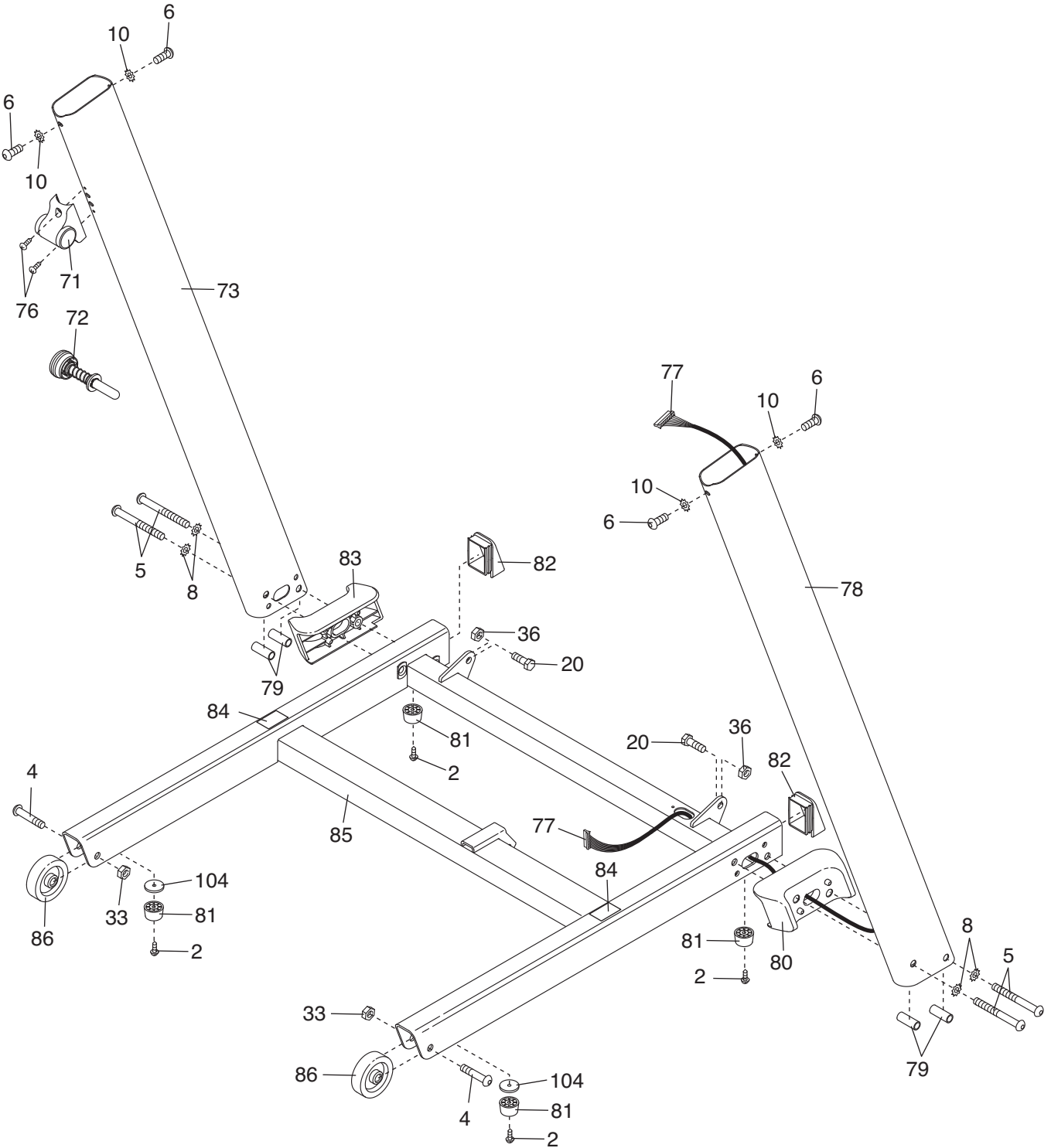

# EXPLODED DRAWING D—Model No. PCTL57809.0

R0909A

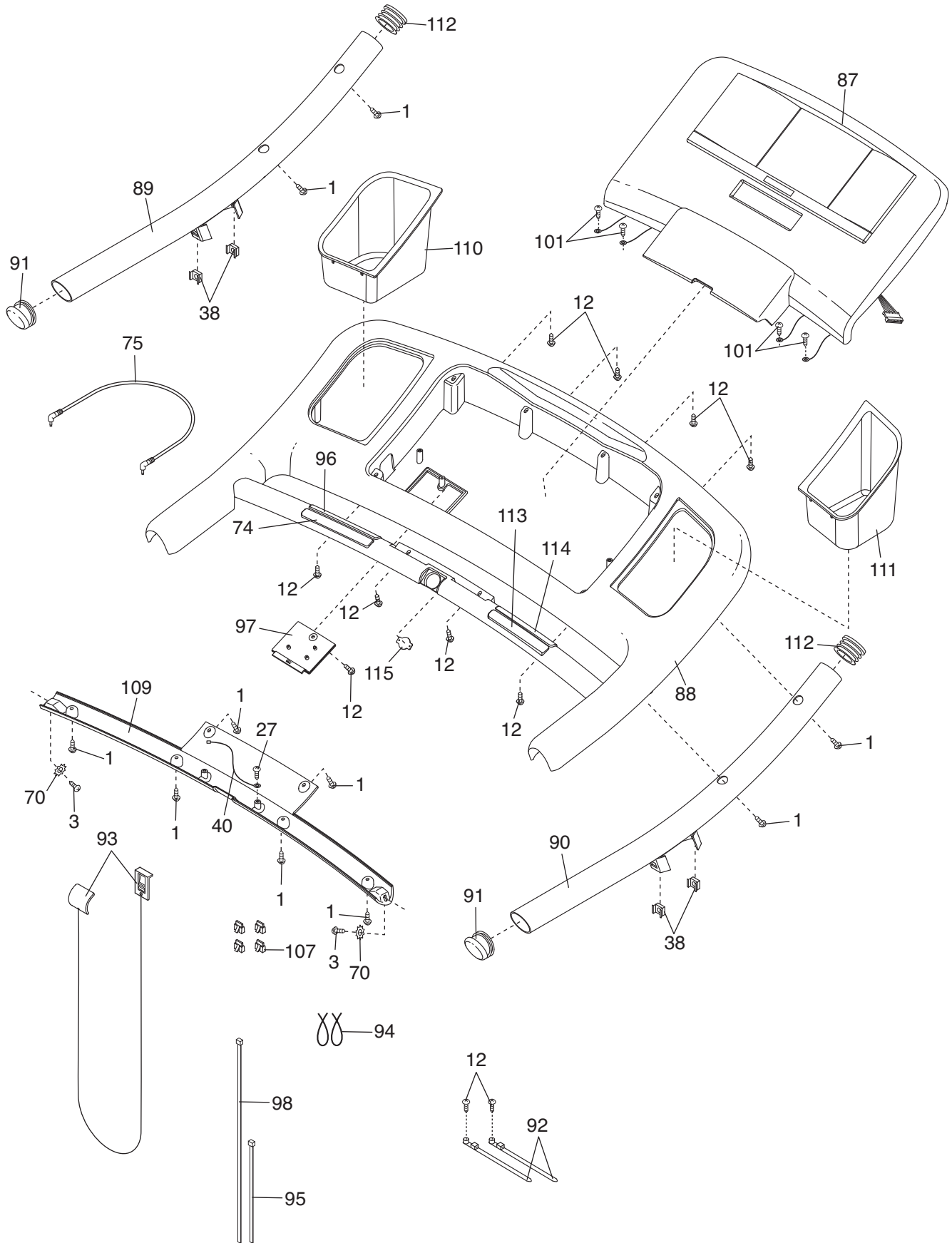

---

# ORDERING REPLACEMENT PARTS

To order replacement parts, please see the front cover of this manual. To help us assist you, be prepared to provide the following information when contacting us:

- the model number and serial number of the product (see the front cover of this manual)
- the name of the product (see the front cover of this manual)
- the key number and description of the replacement part(s) (see the PART LIST and the EXPLODED DRAWING near the end of this manual)

## LIMITED WARRANTY

ICON of Canada, Inc. (ICON) warrants this product to be free from defects in workmanship and material, under normal use and service conditions. The drive motor is warranted for ten (10) years from the date of purchase. Parts and labor are warranted for ninety (90) days from the date of purchase.

This warranty extends only to the original purchaser. ICON's obligation under this warranty is limited to repairing or replacing, at ICON's option, the product through one of its authorized service centers. All repairs for which warranty claims are made must be preauthorized by ICON. This warranty does not extend to any damage to a product caused by or attributable to freight damage, abuse, misuse, improper or abnormal usage, or repairs not provided by an ICON authorized service center; products used for commercial or rental purposes; or products used as store display models. No other warranty beyond that specifically set forth above is authorized by ICON.

ICON is not responsible or liable for indirect, special, or consequential damages arising out of or in connection with the use or performance of the product; damages with respect to any economic loss, loss of property, loss of revenues or profits, loss of enjoyment or use, or costs of removal or installation; or other consequential damages of whatsoever nature. Some provinces do not allow the exclusion or limitation of incidental or consequential damages. Accordingly, the above limitation may not apply to you.

The warranty extended hereunder is in lieu of any and all other warranties, and any implied warranties of merchantability or fitness for a particular purpose are limited in their scope and duration to the terms set forth herein. Some provinces do not allow limitations on how long an implied warranty lasts. Accordingly, the above limitation may not apply to you.

This warranty gives you specific legal rights. You may also have other rights that vary from province to province.

**ICON of Canada, Inc., 900 de l'Industrie, St. Jérôme, QC J7Y 4B8**

## Free Manuals Download Website

<http://myh66.com>

<http://usermanuals.us>

<http://www.somanuals.com>

<http://www.4manuals.cc>

<http://www.manual-lib.com>

<http://www.404manual.com>

<http://www.luxmanual.com>

<http://aubethermostatmanual.com>

Golf course search by state

<http://golfingnear.com>

Email search by domain

<http://emailbydomain.com>

Auto manuals search

<http://auto.somanuals.com>

TV manuals search

<http://tv.somanuals.com>