

# PRO-FORM<sup>®</sup>

## G705

Model No. PFBE14530

Serial No. \_\_\_\_\_

Write the serial number in the space above for future reference.

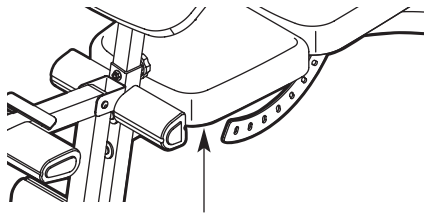

Serial Number Decal (Under Seat)

## USER'S MANUAL

### QUESTIONS?

As a manufacturer, we are committed to providing complete customer satisfaction. If you have questions, or if there are missing or damaged parts, we will guarantee complete satisfaction through direct assistance from our factory.

**TO AVOID DELAYS, PLEASE CALL DIRECT TO OUR TOLL-FREE CUSTOMER HOT LINE.** The trained technicians on our customer hot line will provide immediate assistance, free of charge.

**CUSTOMER HOT LINE:**

**1-800-999-3756**

Mon.–Fri., 6 a.m.–6 p.m. MST

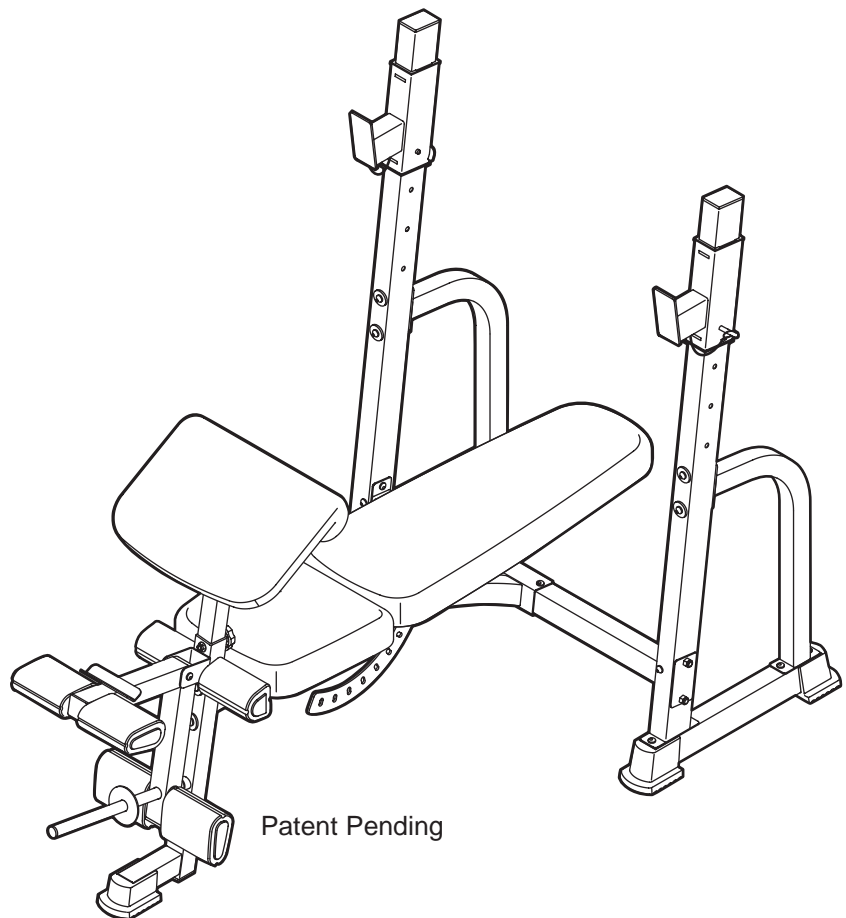

Patent Pending

### CAUTION

Read all precautions and instructions in this manual before using this equipment. Save this manual for future reference.



Visit our website at

[www.proform.com](http://www.proform.com)

*new products, prizes,  
fitness tips, and much more!*

---

# TABLE OF CONTENTS

WARNING DECAL PLACEMENT .....	2
IMPORTANT PRECAUTIONS .....	3
BEFORE YOU BEGIN .....	4
ASSEMBLY .....	5
ADJUSTMENTS .....	10
EXERCISE GUIDELINES .....	12
ORDERING REPLACEMENT PARTS .....	Back Cover
LIMITED WARRANTY .....	Back Cover

Note: A PART IDENTIFICATION CHART and a PART LIST/EXPLODED DRAWING is attached in the center of this manual. Remove the PART IDENTIFICATION CHART and PART LIST/EXPLODED DRAWING before beginning assembly.

---

## WARNING DECAL PLACEMENT

The decals shown here have been placed on the weight bench. If a decal is missing or illegible, please call our Customer Service Department toll-free at 1-800-999-3756, Monday through Friday, 6 a.m. until 6 p.m. Mountain Time, to order a free replacement decal. Apply the decal in the location shown.

**! WARNING**

- Misuse of this product may result in serious injury.
- Read user's manual and follow all warnings and operating instructions prior to use.
- Do not allow children on or around machine.
- Replace label if damaged, illegible, or removed.

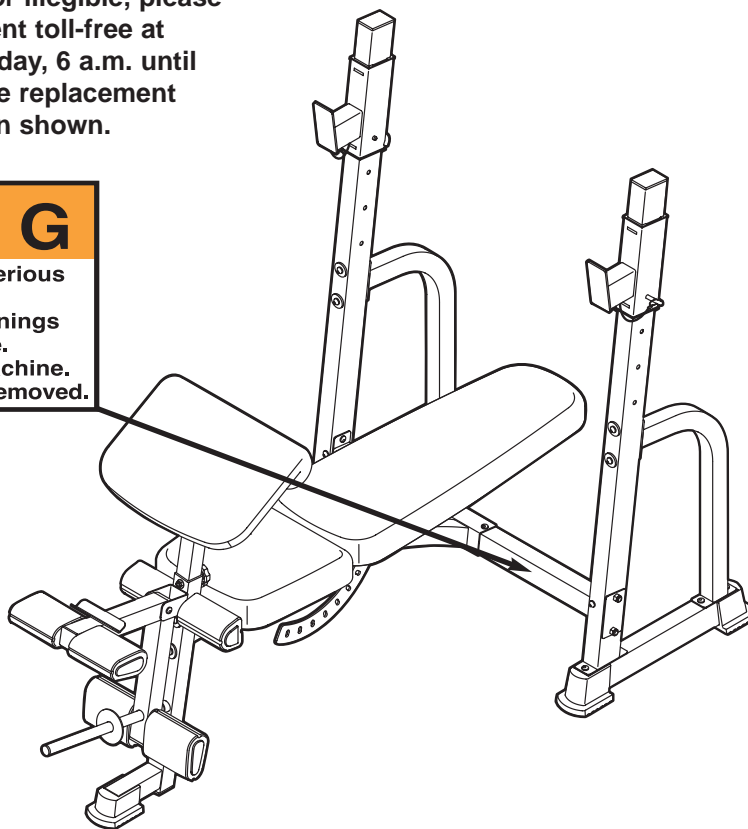

# IMPORTANT PRECAUTIONS

**⚠ WARNING:** To reduce the risk of serious injury, read the following important precautions before using the weight bench.

1. Read all instructions in this manual before using the weight bench. Use the weight bench only as described in this manual.
2. It is the responsibility of the owner to ensure that all users of the weight bench are adequately informed of all precautions.
3. The weight bench is intended for home use only. Do not use the weight bench in any commercial, rental, or institutional setting.
4. Use the weight bench only on a level surface. Cover the floor beneath the weight bench to protect the floor.
5. Make sure that all parts are properly tightened each time the weight bench is used. Replace any worn parts immediately.
6. Always wear athletic shoes for foot protection while exercising.
7. Keep children under 12 and pets away from the weight bench at all times.
8. Keep hands and feet away from moving parts.
9. Make sure that the weight rest pins are in locked position around the uprights before beginning any exercise.
10. The weight bench is designed to support a maximum user weight of 300 pounds, and a maximum total weight of 510 pounds. Do not place more than 210 pounds, including a barbell and weights, on the weight rests. Do not place more than 130 pounds on the leg lever. Note: The weight bench does not include a barbell or weights.
11. Always make sure that there is an equal amount of weight on each side of your barbell when you are using it. Always keep some weight on both ends of the barbell when adding or removing weights to prevent the barbell from tipping.
12. When you put weight on the weight rests, make sure that you put at least ten pounds on the leg lever to balance the weight bench.
13. When you are using the leg lever, place a barbell with the same amount of weight on the weight rests to balance the bench.
14. Always remove the curl post from the front leg before performing leg curls with the leg lever.
15. Always exercise with a partner. When you are performing bench press exercises, your partner should stand behind you to catch the barbell if you cannot complete a repetition.
16. If you feel pain or dizziness at any time while exercising, stop immediately and begin cooling down.

**⚠ WARNING:** Before beginning this or any exercise program, consult your physician. This is especially important for persons over the age of 35 or persons with pre-existing health problems. Read all instructions before using. ICON assumes no responsibility for personal injury or property damage sustained by or through the use of this product.

# BEFORE YOU BEGIN

Thank you for selecting the versatile PROFORM® C705 weight bench. The weight bench offers a selection of weight stations designed to develop every major muscle group of the body. Whether your goal is to tone your body, build dramatic muscle size and strength, or improve your cardiovascular system, the weight bench will help you to achieve the specific results you want.

**For your benefit, read this manual carefully before using the weight bench.** If you have additional questions, please call our Customer Service Department

toll-free at 1-800-999-3756, Monday through Friday, 6 a.m. until 6 p.m. Mountain Time (excluding holidays). To help us assist you, please note the product model number and serial number before calling. The model number is PFBE14530. The serial number can be found on a decal attached to the weight bench (see the front cover of this manual).

Before reading further, please review the drawing below and familiarize yourself with the parts that are labeled.

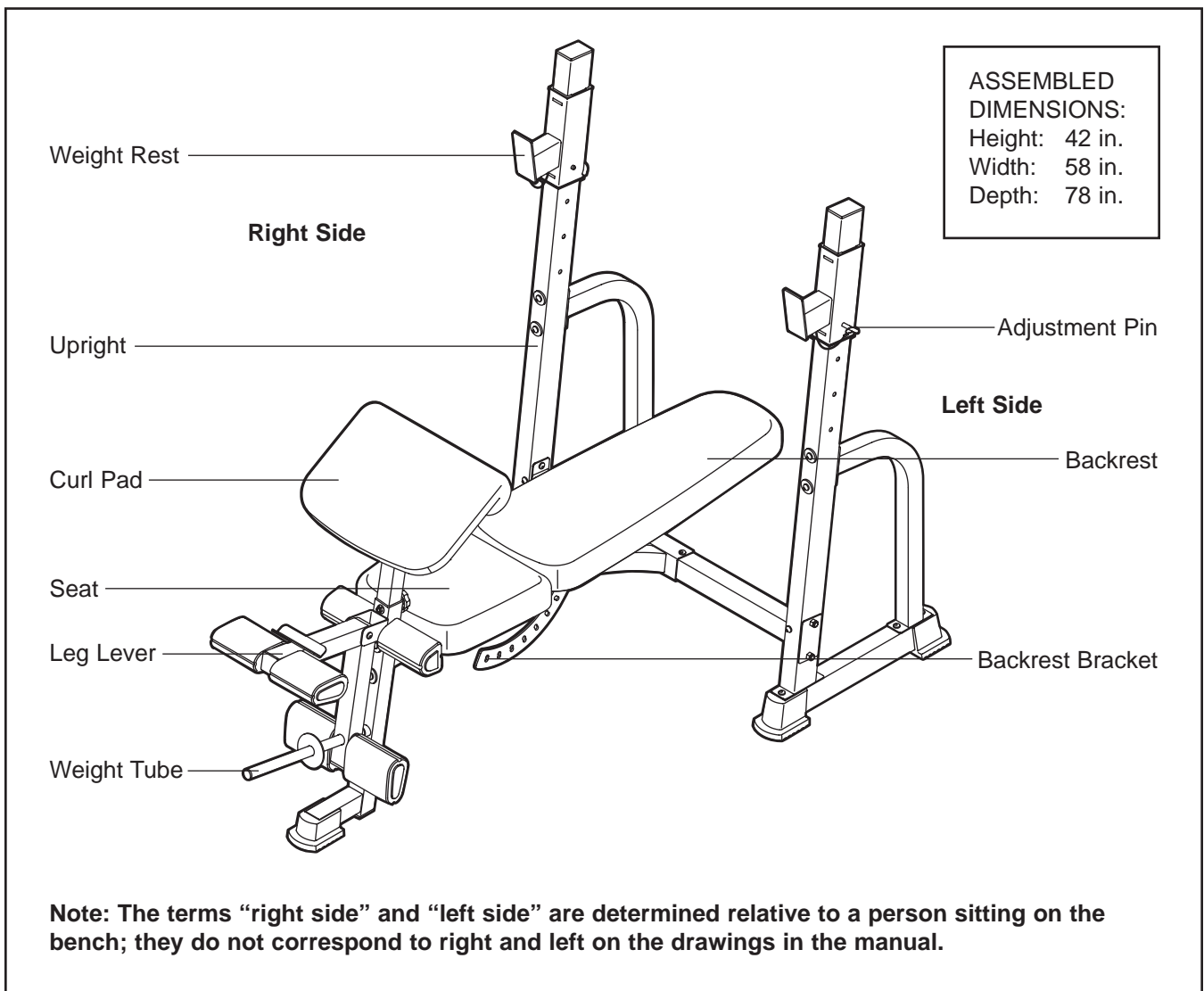

# ASSEMBLY

## Make Things Easier for Yourself





Everything in this manual is designed to ensure that the weight bench can be assembled successfully by anyone. However, it is important to realize that the versatile weight bench has many parts and that the assembly process will take time. Most people find that by setting aside plenty of time, assembly will go smoothly.

**Before beginning assembly, carefully read the following information and instructions:**

- Assembly requires two persons.
- Place all parts in a cleared area and remove the packing materials. Do not dispose of the packing materials until assembly is completed.
- Tighten all parts as you assemble them, unless instructed to do otherwise.

- As you assemble the weight bench, make sure all parts are oriented as shown in the drawings.
- For help identifying small parts, use the **PART IDENTIFICATION CHART**.

**The following tools (not included) are required for assembly:**

- **Two adjustable wrenches** 
- **One rubber mallet** 
- **One standard screwdriver** 
- **One Phillips screwdriver** 
- **Lubricant, such as grease or petroleum jelly, and soapy water.**

Assembly will be more convenient if you have a socket set, a set of open-end or closed-end wrenches, or a set of ratchet wrenches.

1. **Before beginning assembly, make sure that you understand the information in the box above. For help identifying small parts, use the PART IDENTIFICATION CHART.**

Attach a Support (6) and a Large Base Foot (15) to a Stabilizer (3) with two M10 x 93mm Button Bolts (37), an M10 Washer (41), an M10 Nylon Locknut (43), and an M10 Nylon Jamnut (46). **Do not tighten the Locknut and Jamnut yet.**

Secure the Large Base Foot (15) to the Stabilizer (3) with an M4 x 16mm Screw (39).

**Repeat this step with the other Stabilizer (3) and Support (6).**

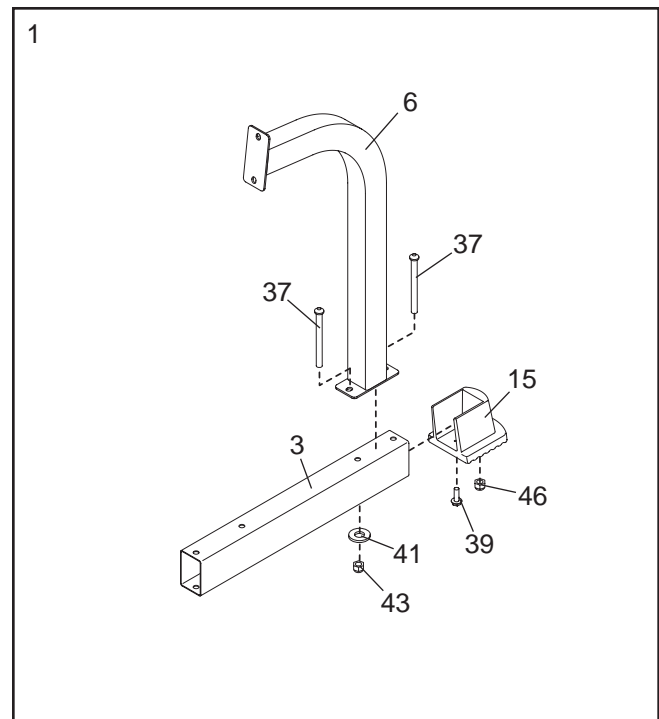

2. Locate the Left Upright (5), which has a name decal in the indicated location. Press a 2" x 3" Inner Cap (30) into the Upright.

Attach the Left Upright (5) and a Large Base Foot (15) to a Stabilizer (3) with two M10 x 93mm Button Bolts (37), an M10 Washer (41), an M10 Nylon Locknut (43), and an M10 Nylon Jamnut (46). **Do not tighten the Locknut and Jamnut yet.**

Secure the Large Base Foot (15) to the Stabilizer (3) with an M4 x 16mm Screw (39).

Attach the Left Upright (5) to the Support (6) with two M10 x 93mm Button Bolts (37), two M10 Washers (41), and two M10 Nylon Locknuts (43). **Do not tighten the Locknuts yet.**

**Repeat this step with the Right Upright (not shown).**

**Tighten the M10 Nylon Locknuts (43) and the M10 Nylon Jamnuts (46) used in steps 1 and 2.**

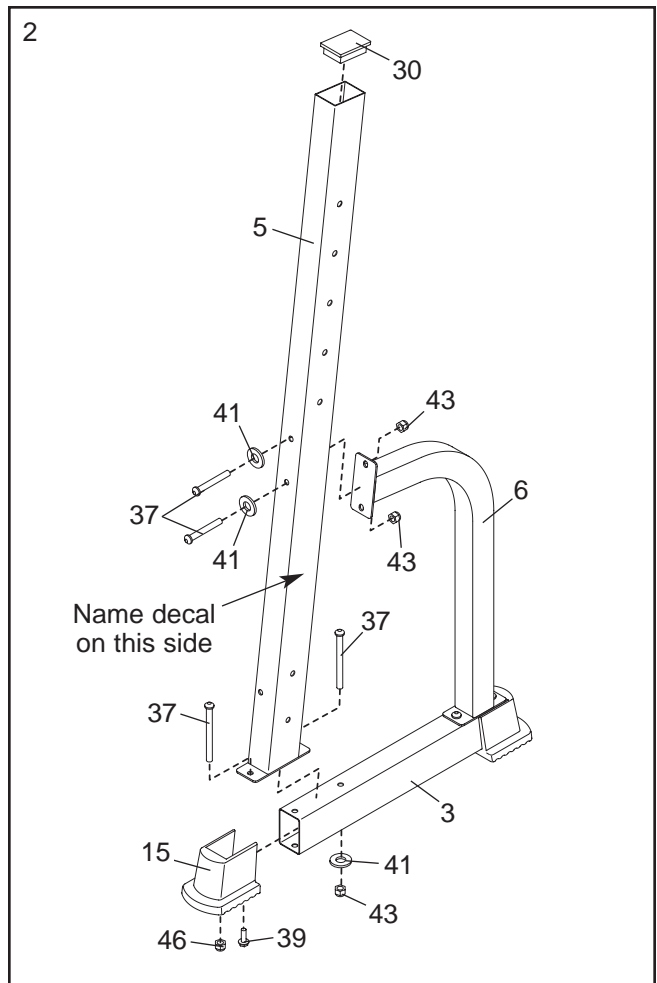

3. Attach the Crossbar (4) to the Left Upright (5) with two M10 x 68mm Button Bolts (38), a Support Plate (47), and two M10 Nylon Locknuts (43). **Do not tighten the Locknuts yet.**

Next, attach the Crossbar (4) to the Left Upright (5) with an M10 x 93mm Button Bolt (37), an M10 Washer (41), and an M10 Nylon Locknut (43). **Do not tighten the Locknut yet.**

**Repeat this step with the Right Upright (not shown).**

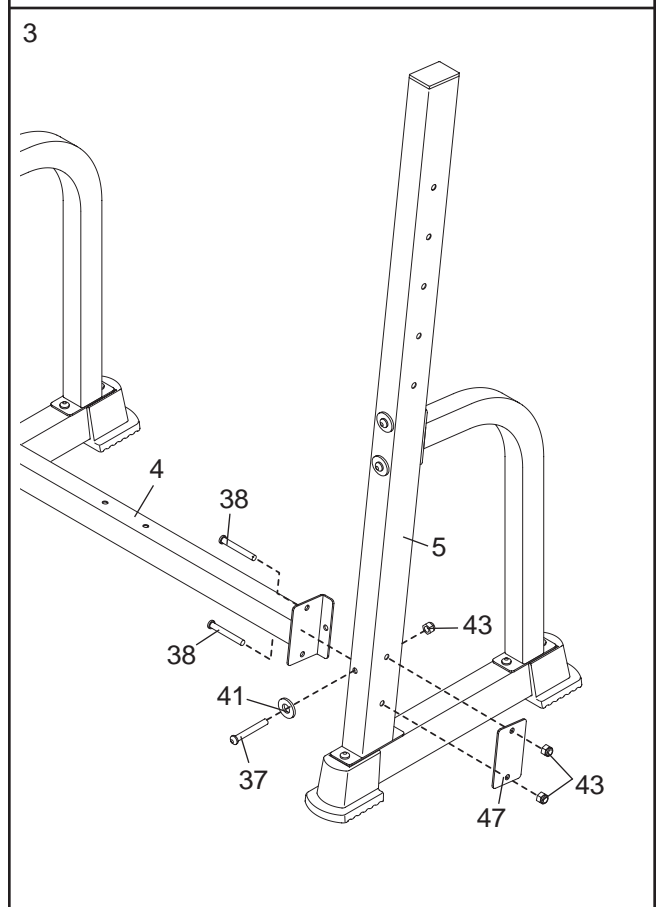

- Attach a Small Base Foot (14) to the Bench Leg (2) with an M4 x 16mm Screw (39). Press a 50mm Square Inner Cap (25) and a 50mm Notched Square Inner Cap (50) into the Bench Leg.

Attach the Bench Leg (2) to the Bench Frame (1) with two M10 x 68mm Button Bolt (38), two M10 Washers (41), and two M10 Nylon Locknuts (43). **Do not tighten the Locknuts yet.**

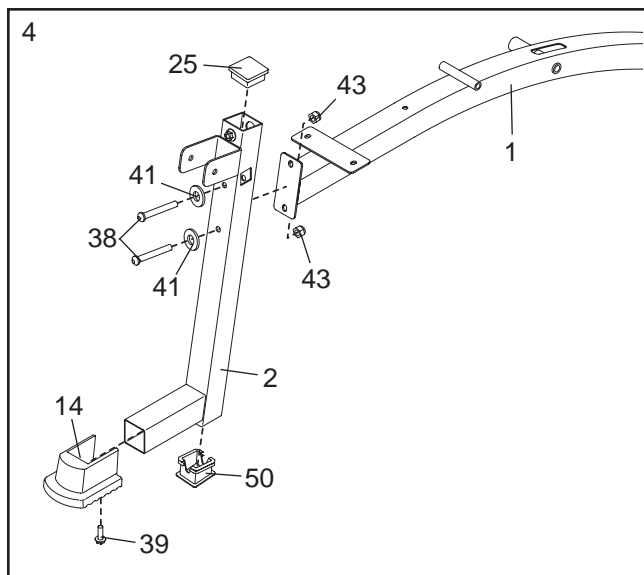

- Attach the Bench Frame (1) to the Crossbar (4) with two M10 x 68mm Button Bolts (38) and two M10 Nylon Locknuts (56). **Do not tighten the Locknuts yet.**

**Tighten the M10 Nylon Locknuts (43) used in steps 3–6.**

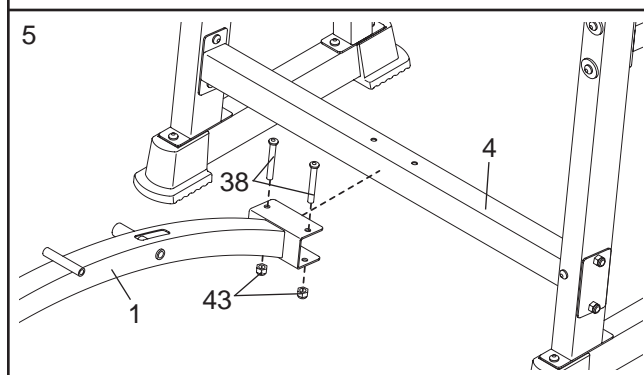

- Press two 50mm Square Inner Caps (25) into the Leg Lever (7). Press a 25mm Round Inner Cap (45) into the Weight Tube (13).

Attach the Weight Tube (13) to the Leg Lever (7) with an M8 x 63mm Button Bolt (49), two M8 Washers (26), a 12.5mm Spacer (31), and an M8 Nylon Locknut (44). Press the 25mm Round Angled Cap (32) onto the Weight Tube.

Lubricate an M10 x 73mm Button Bolt (42) with grease. Attach the Leg Lever (7) to the Bench Leg (2) with the Bolt and an M10 Nylon Locknut (43). **Do not overtighten the Locknut; the Leg Lever must be able to pivot easily.**

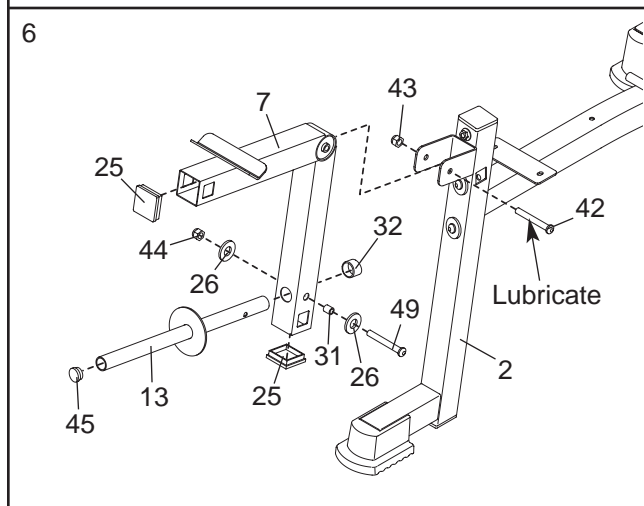

- Attach the tether on the Weight Rest Pin (23) to a Weight Rest (11) with an M4 x 16mm Screw (39).

Slide a Weight Rest (11) onto the Left Upright (5). Insert the Weight Rest Pin (23) into the Weight Rest and an adjustment hole in the Upright from the side shown. Rotate the Pin down so that it wraps around the back of the Upright.

**Repeat this step with the other Weight Rest (11) and the Right Upright (not shown). Make sure that the two Weight Rests are set at the same height.**

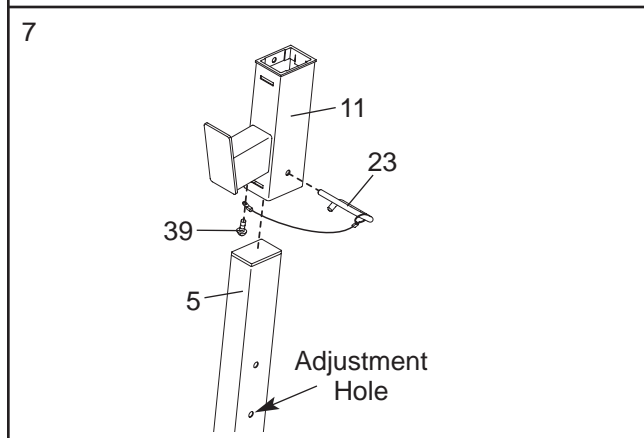

8. Press four 25mm Square Inner Caps (24) into the Backrest Tubes (9).

Orient the Backrest Tubes (9) so that the indicated holes are closer to the bottom. Attach the Backrest Bracket (8) to the Backrest Tubes with four M10 x 45mm Button Bolts (35), four M10 Washers (41), and four M10 Nylon Locknuts (43). **Do not tighten the Locknuts yet.**

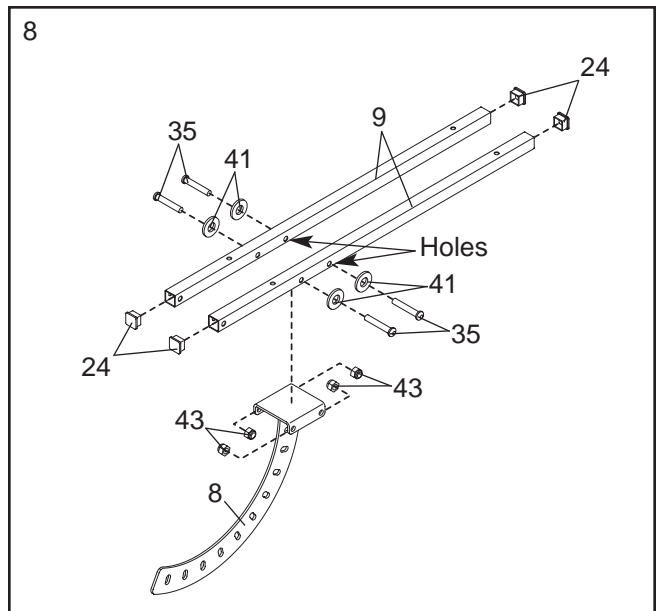

9. Pull out the Pop Pin (22) as far as it will go. Insert the Backrest Bracket (8) through the slot in the Bench Frame (1). Engage the Pop Pin into a hole in the Backrest Bracket.

Lubricate an M10 x 155mm Button Bolt (36) with grease. Attach the Backrest Tubes (9) to the Bench Frame (1) with the Bolt, two M10 Washers (41), and an M10 Nylon Locknut (43). **Do not overtighten the Locknut; the Backrest Tubes must be able to pivot easily.**

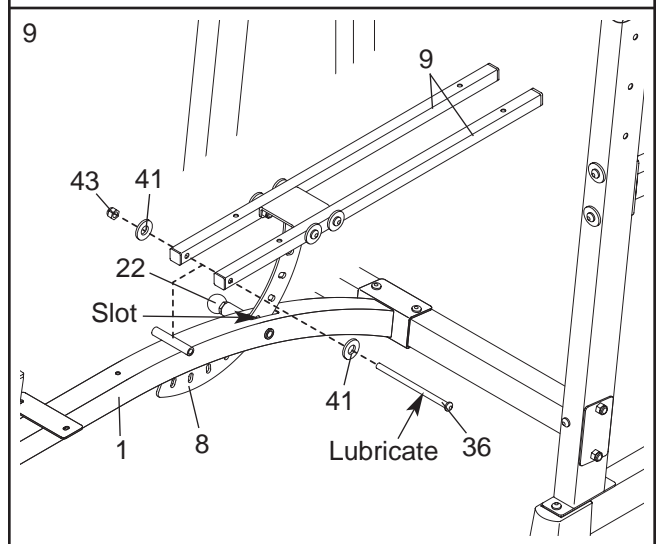

10. Attach the Backrest (17) to the Backrest Tubes (9) with four M6 x 38mm Screws (48) and four M6 Washers (34).

**Tighten the four M10 Nylon Locknuts (43) used in step 8.**

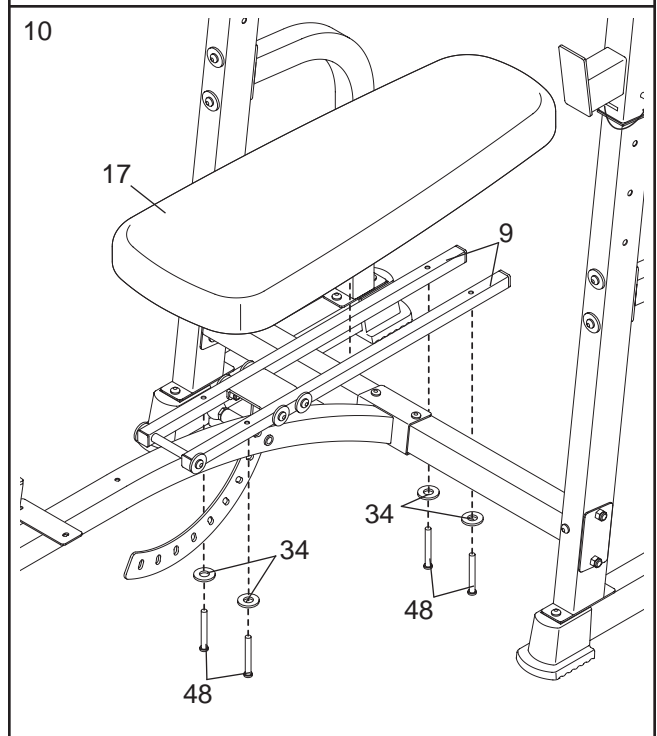



11. Attach the Seat (16) to the Bench Frame (1) with an M6 x 63mm Screw (33), an M6 Washer (34), and two M6 x 16mm Screws (40).

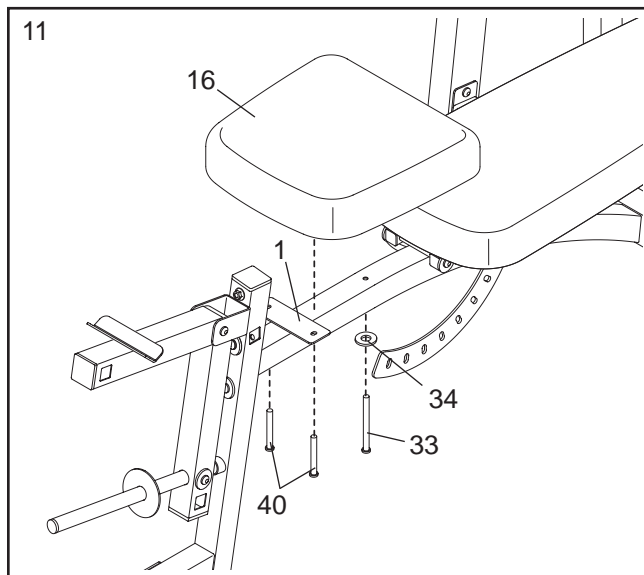

12. Slide a Pad Tube (12) into a hole in the Leg Lever (7). Wet both sides of the Pad Tube with soapy water. Slide two Large Pads (19) onto the Pad Tube as shown. Press two Large Pad Caps (29) into the Pad Tube. **Repeat with another Pad Tube and the Leg Lever.**

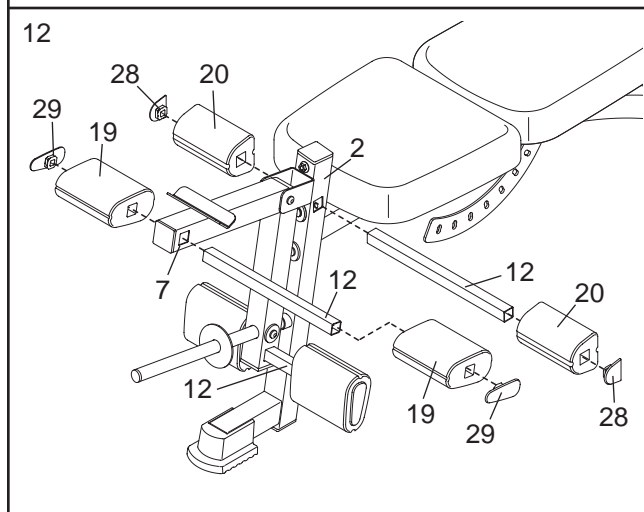

Slide the last Pad Tube (12) into the hole in the Bench Leg (2). Wet both sides of the Pad Tube with soapy water. Slide two Small Pads (20) onto the Tube as shown. Press two Small Pad Caps (28) into the Pad Tube.

13. Attach the Curl Pad (18) to the Curl Post (10) with two M6 x 16mm Screws (40).

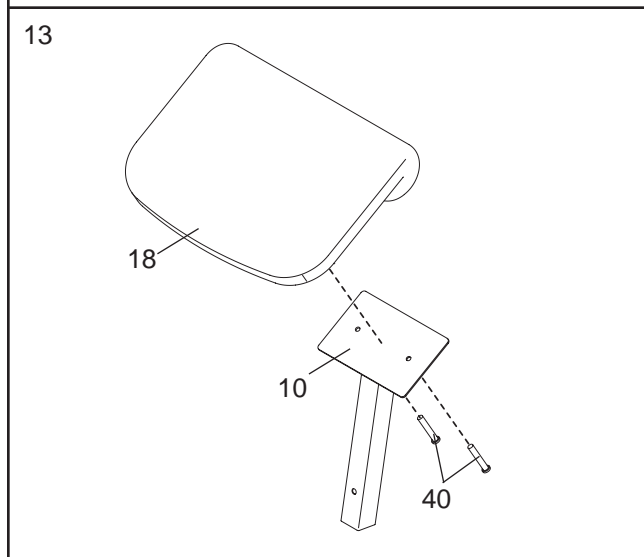

14. **Make sure that that all parts are properly tightened before you use the weight bench.** The use of all remaining parts will be explained in ADJUSTMENTS, beginning on the following page.

# ADJUSTMENTS

The weight bench is designed to be used with your own weight set (not included). The steps below explain how the weight bench can be adjusted. See EXERCISE GUIDELINES on page 12 for important exercise information and refer to the accompanying exercise guide to see the correct form for each exercise. Refer also to the exercise information accompanying your weight set for additional exercises.

Make sure all parts are properly tightened each time the weight bench is used. Replace any worn parts immediately. The weight bench can be cleaned with a damp cloth and a mild, non-abrasive detergent. Do not use solvents.

## ADJUSTING THE BACKREST

To adjust the position of the Backrest (17), hold the upper end of the Backrest with one hand and pull the Pop Pin (22 [not shown]) out. Raise or lower the Backrest to the desired position. Engage the Pop Pin into an adjustment hole in the Backrest Bracket (8).

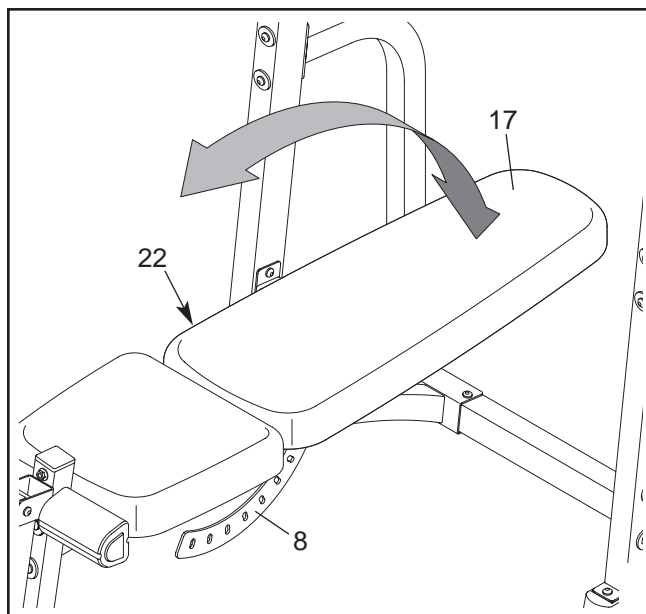

## ATTACHING WEIGHTS TO THE LEG LEVER

To use the Leg Lever (7), slide the desired weights (not included) onto the Weight Tube (13).

**⚠ WARNING:** Do not place more than 150 pounds on the Weight Tube (13).

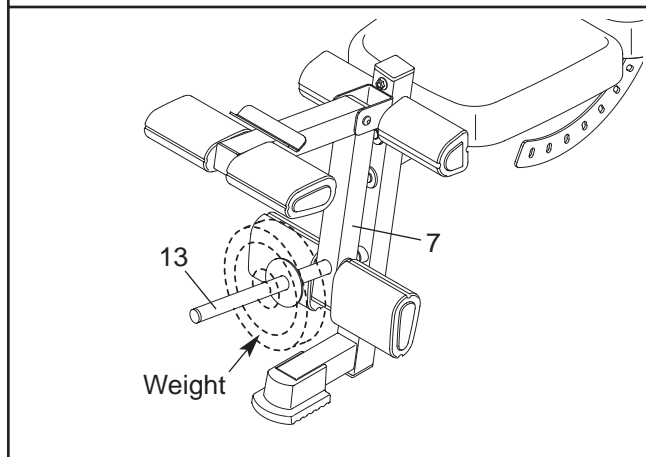

## ADJUSTING THE WEIGHT RESTS

To change the height of a Weight Rest (11), remove the Weight Rest Pin (23). Position the Weight Rest at the desired height on the Upright (5 or 51 [not shown]) and secure it with the Pin.

**⚠ WARNING:** Always set both Weight Rests (11) at the same height. Make sure that the Weight Rest Pins (23) are wrapped around the back of the Uprights (5, 51).

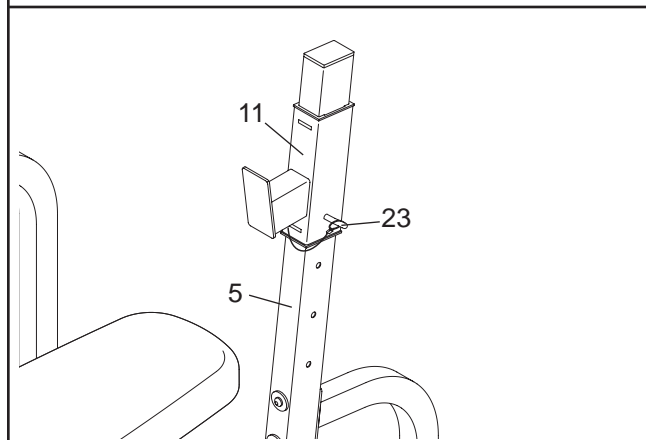

## ATTACHING THE CURL POST

For some exercises, the Curl Post (10) must be attached to the weight bench. Remove the 50mm Square Inner Cap (25). Slide the Curl Post into the bench Leg (2). Align the adjustment holes in the Curl Post with the adjustment hole in the Bench Leg. Tighten the Curl Knob (27) into the Bench Leg. **Fully tighten the Knob.**

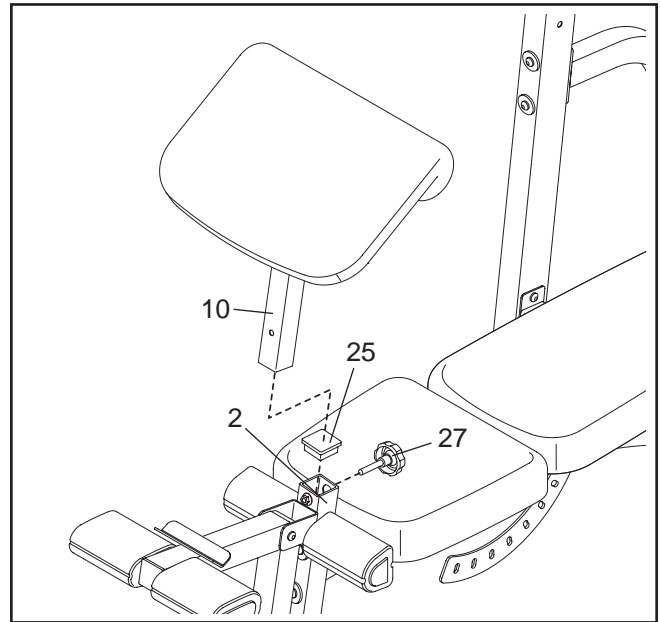

---

# EXERCISE GUIDELINES

## THE FOUR BASIC TYPES OF WORKOUTS

### MUSCLE BUILDING

To increase the size and strength of your muscles, push them close to their maximum capacity. Your muscles will continually adapt and grow as you progressively increase the intensity of your exercise. You can adjust the intensity level of an individual exercise in two ways:

- by changing the amount of resistance used
- by changing the number of repetitions or sets performed. (A “repetition” is one complete cycle of an exercise, such as one sit-up. A “set” is a series of repetitions.)

The proper amount of resistance for each exercise depends upon the individual user. You must gauge your limits and select the amount of resistance that is right for you. Begin with 3 sets of 8 repetitions for each exercise you perform. Rest for 3 minutes after each set. When you can complete 3 sets of 12 repetitions without difficulty, increase the amount of resistance.

### TONING

You can tone your muscles by pushing them to a moderate percentage of their capacity. Select a moderate amount of resistance and increase the number of repetitions in each set. Complete as many sets of 15 to 20 repetitions as possible without discomfort. Rest for 1 minute after each set. Work your muscles by completing more sets rather than by using high amounts of resistance.

### WEIGHT LOSS

To lose weight, use a low amount of resistance and increase the number of repetitions in each set. Exercise for 20 to 30 minutes, resting for a maximum of 30 seconds between sets.

### CROSS TRAINING

Cross training is an efficient way to get a complete and well-balanced fitness program. An example of a balanced program is:

- Plan strength training workouts on Monday, Wednesday, and Friday.
- Plan 20 to 30 minutes of aerobic exercise, such as running on a treadmill or riding on an elliptical or exercise bike, on Tuesday and Thursday.
- Rest from both strength training and aerobic exercise for at least one full day each week to give your body time to regenerate.

The combination of strength training and aerobic exercise will reshape and strengthen your body, plus develop your heart and lungs.

## PERSONALIZING YOUR EXERCISE PROGRAM

Determining the exact length of time for each workout, as well as the number of repetitions or sets completed, is an individual matter. It is important to avoid overdoing it during the first few months of your exercise program. You should progress at your own pace and be sensitive to your body’s signals. If you experience pain or dizziness at any time while exercising, stop immediately and begin cooling down. Find out what is wrong before continuing. Remember that adequate rest and a proper diet are important factors in any exercise program.

### WARMING UP

Begin each workout with 5 to 10 minutes of stretching and light exercise to warm up. Warming up prepares your body for more strenuous exercise by increasing circulation, raising your body temperature and delivering more oxygen to your muscles.

### WORKING OUT

Each workout should include 6 to 10 different exercises. Select exercises for every major muscle group, emphasizing areas that you want to develop most. To give balance and variety to your workouts, vary the exercises from session to session.

Schedule your workouts for the time of day when your energy level is the highest. Each workout should be followed by at least one day of rest. Once you find the schedule that is right for you, stick with it.

### EXERCISE FORM

Maintaining proper form is an essential part of an effective exercise program. This requires moving through the full range of motion for each exercise, and moving only the appropriate parts of the body. Exercising in an uncontrolled manner will leave you feeling exhausted. On the exercise guide accompanying this manual you will find photographs showing the correct form for several exercises, and a list of the muscles affected. Refer to the muscle chart on the next page to find the names of the muscles.

The repetitions in each set should be performed smoothly and without pausing. The exertion stage of each repetition should last about half as long as the return stage. Proper breathing is important. Exhale during the exertion stage of each repetition and inhale during the return stroke. Never hold your breath.

Rest for a short period of time after each set. The ideal resting periods are:

- Rest for three minutes after each set for a muscle building workout.
- Rest for one minute after each set for a toning workout.
- Rest for 30 seconds after each set for a weight loss workout.

Plan to spend the first couple of weeks familiarizing yourself with the equipment and learning the proper form for each exercise.

### COOLING DOWN

End each workout with 5 to 10 minutes of stretching. Include stretches for both your arms and legs. Move

slowly as you stretch and do not bounce. Ease into each stretch gradually and go only as far as you can without strain. Stretching at the end of each workout is an effective way to increase flexibility.

### STAYING MOTIVATED

For motivation, keep a record of each workout. The chart on pages 14 and 15 of this manual can be photocopied and used to schedule and record your workouts. List the date, the exercises performed, the resistance used, and the numbers of sets and repetitions completed. Record your weight and key body measurements at the end of every month. Remember, the key to achieving the greatest results is to make exercise a regular and enjoyable part of your everyday life.

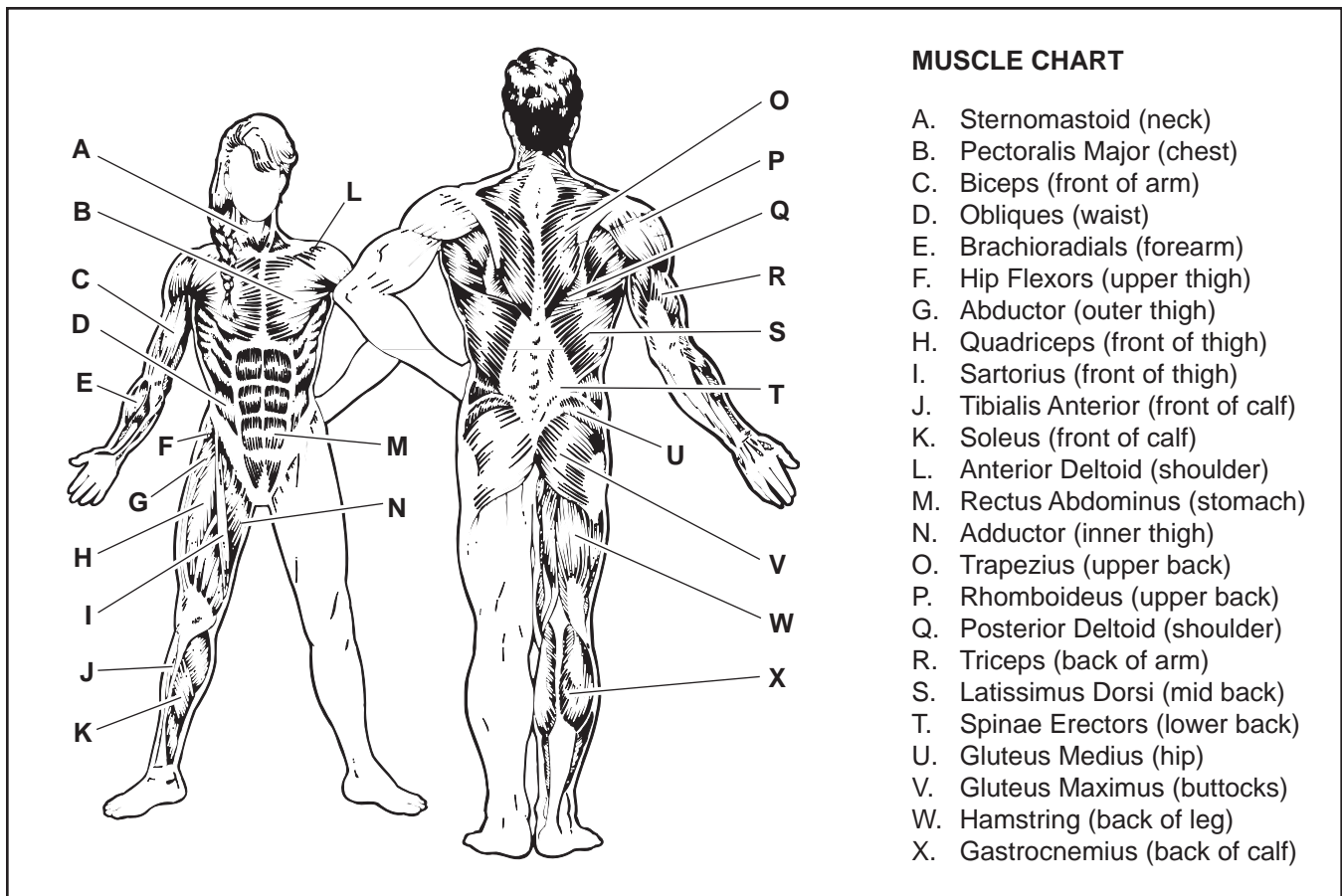

<b>MONDAY</b>	<b>EXERCISE</b>	<b>WEIGHT</b>	<b>SETS</b>	<b>REPS</b>
Date: _____ / _____ / _____				

---

**TUESDAY      AEROBIC EXERCISE**

Date: \_\_\_\_\_ / \_\_\_\_\_ / \_\_\_\_\_

<b>WEDNESDAY</b>	<b>EXERCISE</b>	<b>WEIGHT</b>	<b>SETS</b>	<b>REPS</b>
Date: _____ / _____ / _____				

---

**THURSDAY      AEROBIC EXERCISE**

Date: \_\_\_\_\_ / \_\_\_\_\_ / \_\_\_\_\_

<b>FRIDAY</b>	<b>EXERCISE</b>	<b>WEIGHT</b>	<b>SETS</b>	<b>REPS</b>
Date: _____ / _____ / _____				

Make photocopies of this page for scheduling and recording your workouts.

# PART IDENTIFICATION CHART

Refer to the drawings below to identify small parts used in assembly. The number in parentheses by each drawing is the key number of the part, from the PART LIST in the center of this manual. **Note: Some small parts may have been pre-attached. If a part is not in the parts bag, check to see if it has been pre-attached.**

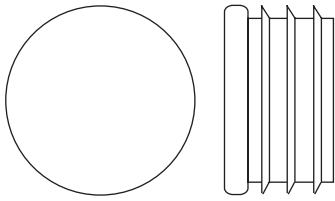

25mm Round Inner Cap (45)

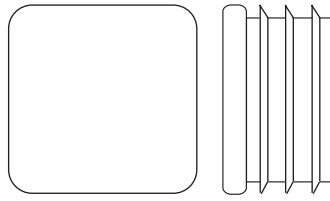

25mm Square Inner Cap (24)

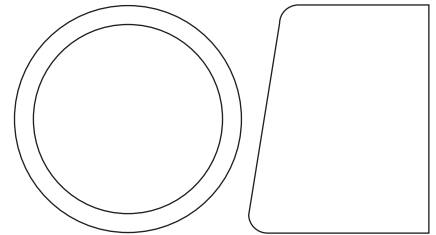

25mm Round Angle Cap (32)

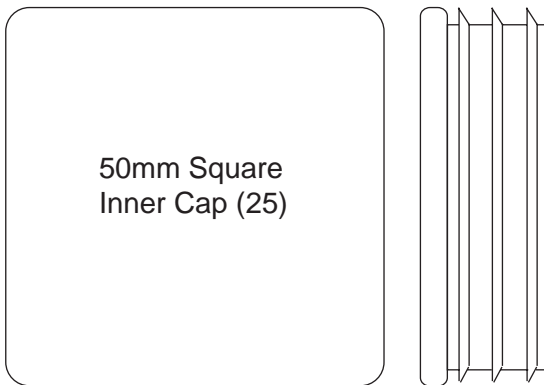

50mm Square Inner Cap (25)

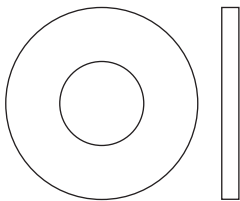

M10 Washer (41)

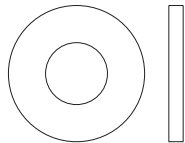

M8 Washer (26)

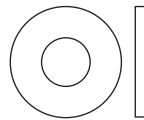

M6 Washer (34)

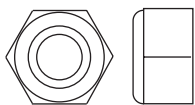

M8 Nylon Locknut (44)

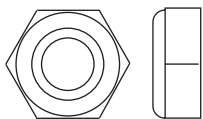

M10 Nylon Jamnut (46)

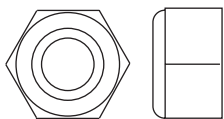

M10 Nylon Locknut (43)

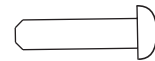

M4 x 16mm Screw (39)

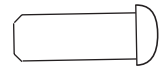

M6 x 16mm Screw (40)

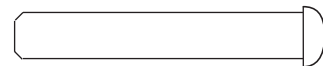

M6 x 38mm Screw (48)

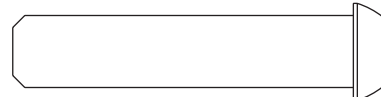

M10 x 45mm Button Bolt (35)

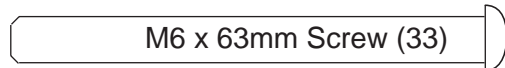

M6 x 63mm Screw (33)



M8 x 63mm Button Bolt (49)

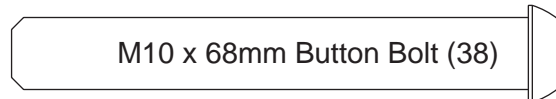

M10 x 68mm Button Bolt (38)



M10 x 73mm Button Bolt (42)

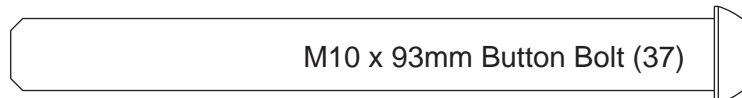

M10 x 93mm Button Bolt (37)

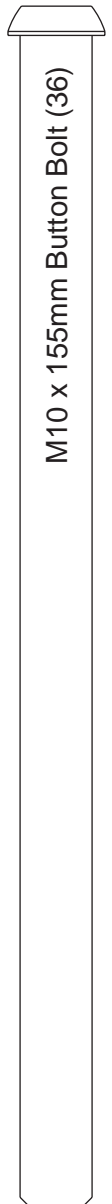

M10 x 155mm Button Bolt (36)

# PART LIST—Model No. PFBE14530

R0803A

Key No.	Qty.	Description	Key No.	Qty.	Description
1	1	Bench Frame	29	4	Large Pad Cap
2	1	Bench Leg	30	2	2" x 3" Inner Cap
3	2	Stabilizer	31	1	12.5mm Spacer
4	1	Crossbar	32	1	25mm Round Angled Cap
5	1	Left Upright	33	1	M6 x 63mm Screw
6	2	Support	34	5	M6 Washer
7	1	Leg Lever	35	4	M10 x 45mm Button Bolt
8	1	Backrest Bracket	36	1	M10 x 155mm Button Bolt
9	2	Backrest Tube	37	14	M10 x 93mm Button Bolt
10	1	Curl Post	38	8	M10 x 68mm Button Bolt
11	2	Weight Rest	39	7	M4 x 16mm Screw
12	3	Pad Tube	40	4	M6 x 16mm Screw
13	1	Weight Tube	41	18	M10 Washer
14	1	Small Base Foot	42	1	M10 x 73mm Button Bolt
15	4	Large Base Foot	43	24	M10 Nylon Locknut
16	1	Seat	44	1	M8 Nylon Locknut
17	1	Backrest	45	1	25mm Round Inner Cap
18	1	Curl Pad	46	4	M10 Nylon Jamnut
19	4	Large Pad	47	2	Support Plate
20	2	Small Pad	48	4	M6 x 38mm Screw
21	4	Weight Rest Bushing	49	1	M8 x 63mm Button Bolt
22	1	Pop Pin	50	1	50mm Notched Inner Cap
23	2	Weight Rest Pin	51	1	Right Upright
24	4	25mm Square Inner Cap	#	1	User's Manual
25	3	50mm Square Inner Cap	#	1	Exercise Guide
26	2	M8 Washer	#	2	Allen Wrench
27	1	Curl Knob	#	1	Grease Pack
28	2	Small Pad Cap			

Note: “#” indicates a non-illustrated part. Specifications are subject to change without notice. See the back cover of the user's manual for information about ordering replacement parts.



# EXPLODED DRAWING—Model No. PFBE14530

R0803A

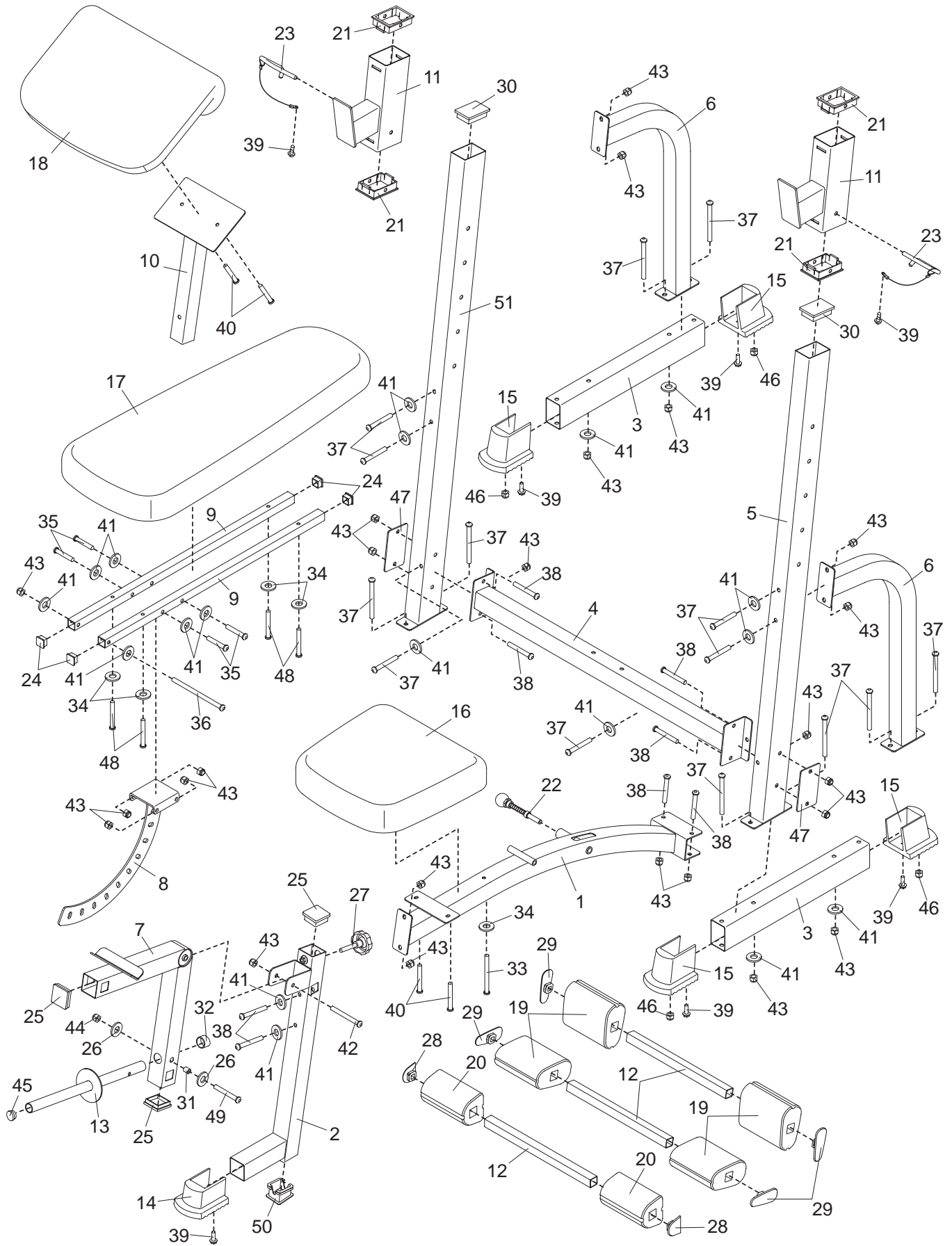

---

## ORDERING REPLACEMENT PARTS

To order replacement parts, simply call our Customer Service Department toll-free at 1-800-999-3756, Monday through Friday, 6 a.m. until 6 p.m. Mountain Time (excluding holidays). To help us assist you, please be prepared to give the following information:

1. The MODEL NUMBER of the product (PFBE14530)
2. The NAME of the product (PROFORM® C705 weight bench)
3. The SERIAL NUMBER of the product (see the front cover of this manual)
4. The KEY NUMBER and DESCRIPTION of the part(s) (see the PART LIST and EXPLODED DRAWING at the center of this manual)

---

## LIMITED WARRANTY

ICON Health & Fitness, Inc. (ICON), warrants this product to be free from defects in workmanship and material, under normal use and service conditions, for a period of ninety (90) days from the date of purchase. This warranty extends only to the original purchaser. ICON's obligation under this warranty is limited to replacing or repairing, at ICON's option, the product through one of its authorized service centers. All repairs for which warranty claims are made must be pre-authorized by ICON. This warranty does not extend to any product or damage to a product caused by or attributable to freight damage, abuse, misuse, improper or abnormal usage or repairs not provided by an ICON authorized service center; products used for commercial or rental purposes; or products used as store display models. No other warranty beyond that specifically set forth above is authorized by ICON.

ICON is not responsible or liable for indirect, special or consequential damages arising out of or in connection with the use or performance of the product or damages with respect to any economic loss, loss of property, loss of revenues or profits, loss of enjoyment or use, costs of removal or installation or other consequential damages of whatsoever nature. Some states do not allow the exclusion or limitation of incidental or consequential damages. Accordingly, the above limitation may not apply to you.

The warranty extended hereunder is in lieu of any and all other warranties and any implied warranties of merchantability or fitness for a particular purpose is limited in its scope and duration to the terms set forth herein. Some states do not allow limitations on how long an implied warranty lasts. Accordingly, the above limitation may not apply to you.

This warranty gives you specific legal rights. You may also have other rights which vary from state to state.

**ICON HEALTH & FITNESS, INC., 1500 S. 1000 W., LOGAN, UT 84321-9813**

## Free Manuals Download Website

<http://myh66.com>

<http://usermanuals.us>

<http://www.somanuals.com>

<http://www.4manuals.cc>

<http://www.manual-lib.com>

<http://www.404manual.com>

<http://www.luxmanual.com>

<http://aubethermostatmanual.com>

Golf course search by state

<http://golfingnear.com>

Email search by domain

<http://emailbydomain.com>

Auto manuals search

<http://auto.somanuals.com>

TV manuals search

<http://tv.somanuals.com>