

PRO-FORM[®]

FUSION 1.6 X

Model No. PFBE1516.0

Serial No. _____

Write the serial number in the space above for future reference.

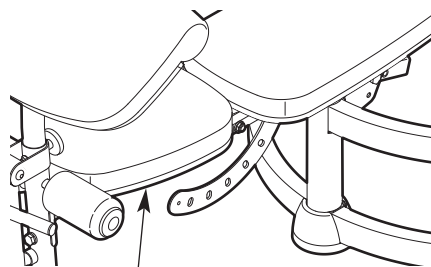

Serial Number Decal

USER'S MANUAL

QUESTIONS?

As a manufacturer, we are committed to providing complete customer satisfaction. If you have questions, or if a part is damaged or missing, PLEASE CONTACT OUR CUSTOMER SERVICE DEPARTMENT DIRECTLY.

CALL TOLL-FREE:

1-888-533-1333

Mon.–Fri., 6 a.m.–6 p.m. MST

ON THE WEB:

www.proformservice.com

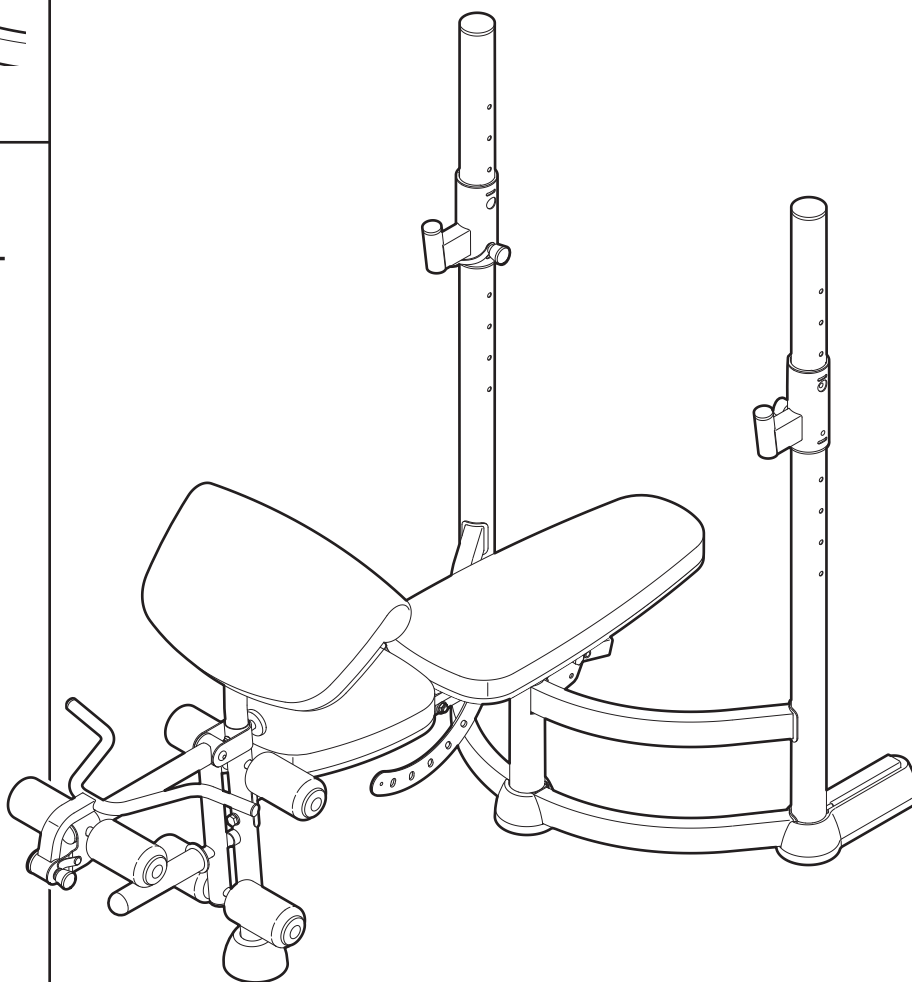

⚠ CAUTION

Read all precautions and instructions in this manual before using this equipment. Save this manual for future reference.



Visit our website at

www.proform.com

new products, prizes,
fitness tips, and much more!

PRO-FORM[®]

FUSION 1.6 X

TABLE OF CONTENTS

IMPORTANT PRECAUTIONS	3
BEFORE YOU BEGIN	4
PART IDENTIFICATION CHART	5
ASSEMBLY	6
ADJUSTMENTS	11
EXERCISE GUIDELINES	13
PART LIST	18
EXPLODED DRAWING	19
ORDERING REPLACEMENT PARTS	Back Cover
LIMITED WARRANTY	Back Cover

IMPORTANT PRECAUTIONS

⚠ WARNING: To reduce the risk of serious injury, read the following important precautions before using the weight bench.

1. Read all instructions in this manual and all warnings on the weight bench before using the weight bench. Use the weight bench only as described in this manual.
2. It is the responsibility of the owner to ensure that all users of the weight bench are adequately informed of all precautions.
3. The weight bench is intended for home use only. Do not use the weight bench in any commercial, rental, or institutional setting.
4. Keep the weight bench indoors, away from moisture and dust. Place the weight bench on a level surface, with a mat beneath it to protect the floor or carpet. Make sure that there is enough clearance around the weight bench to mount, dismount, and use the weight bench.
5. Keep children under 12 and pets away from the weight bench at all times.
6. Inspect and properly tighten all parts regularly. Replace any worn parts immediately.
7. Always make sure that the backrest knob is fully engaged before using the backrest.
8. Wear appropriate clothes when exercising. Always wear athletic shoes for foot protection while exercising.
9. The weight bench is designed to support a maximum user weight of 300 pounds and a maximum total weight of 510 pounds. Do not use the weight bench with more than 210 pounds of weight. Do not place more than 130 pounds on the leg lever. Note: The weight bench does not include weights.
10. If you feel pain or dizziness at any time while exercising, stop immediately and begin cooling down.
11. The decals shown below have been placed on the weight bench. If a decal is missing or illegible, call the toll-free telephone number on the front cover of this manual and order a free replacement decal. Apply the decal in the location shown.

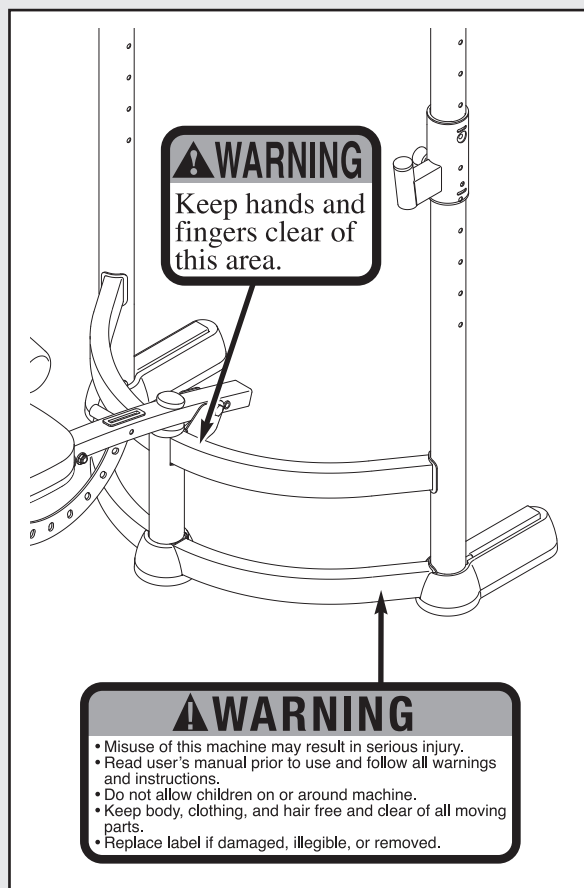

⚠ WARNING: Before beginning this or any exercise program, consult your physician. This is especially important for persons over the age of 35 or persons with pre-existing health problems. Read all instructions before using. ICON assumes no responsibility for personal injury or property damage sustained by or through the use of this product.

BEFORE YOU BEGIN

Thank you for selecting the versatile PROFORM® FUSION 1.6 X weight bench. The weight bench offers a selection of exercise stations designed to develop the major muscle group of the upper body. Whether your goal is to tone your body, build dramatic muscle size and strength, or improve your cardiovascular system, the weight bench will help you to achieve the specific results you want.

For your benefit, read this manual carefully before using the weight bench. If you have questions after reading this manual, please see the front cover of this

manual. To help us assist you, please note the product model number and serial number before contacting us. The model number is PFBE1516.0. The serial number can be found on a decal attached to the weight bench (see the front cover of this manual).

To avoid a registration fee for any service needed under warranty, you must register the weight bench at www.proformservice.com/registration.

Before reading further, please review the drawing below and familiarize yourself with the parts that are labeled.

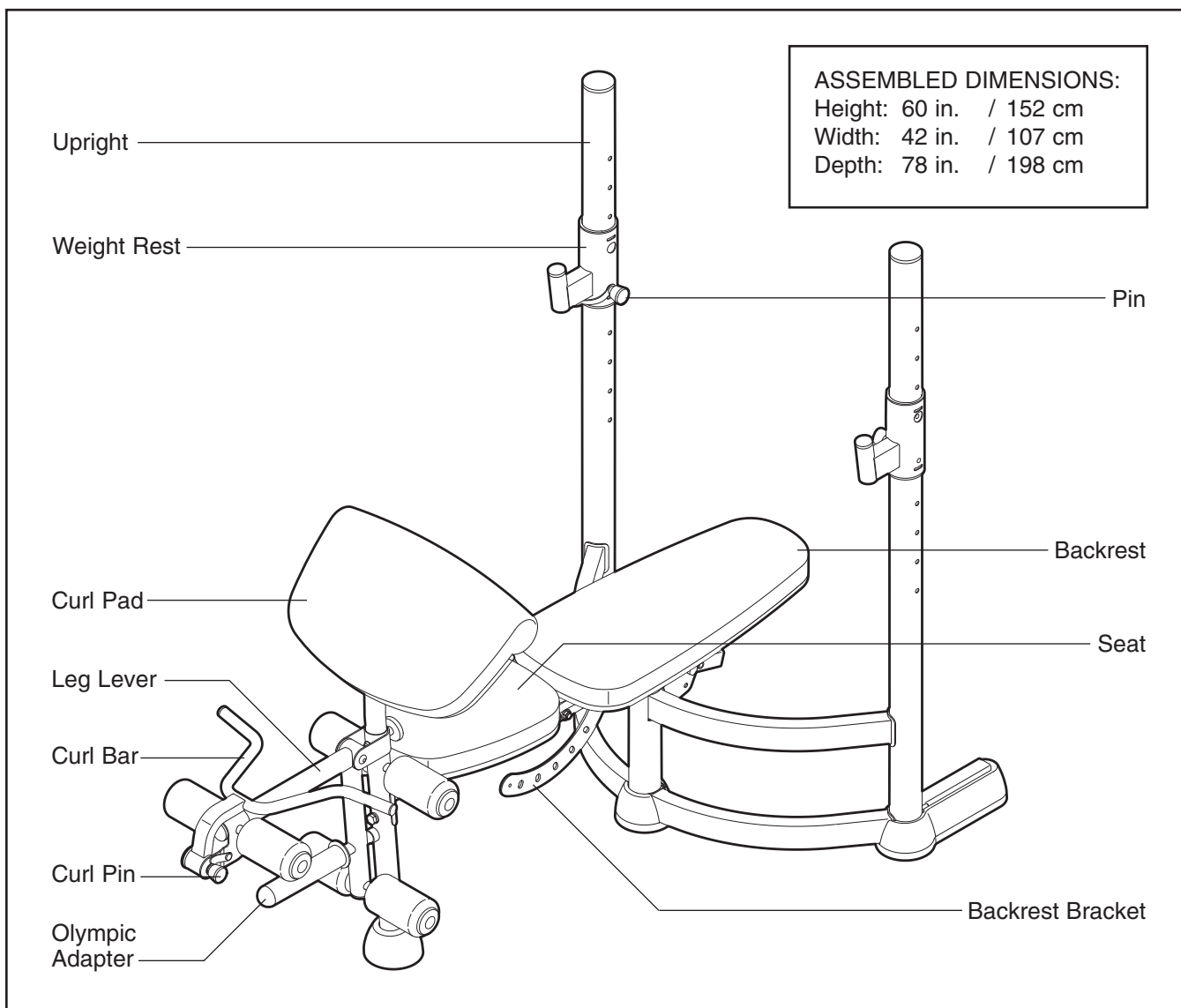

PART IDENTIFICATION CHART

See the drawings below to identify small parts used in assembly. The number in parentheses by each drawing is the key number of the part, from the PART LIST on page 18. **Note: Some small parts may have been pre-attached. If a part is not in the parts bag, check to see if it has been preattached.**

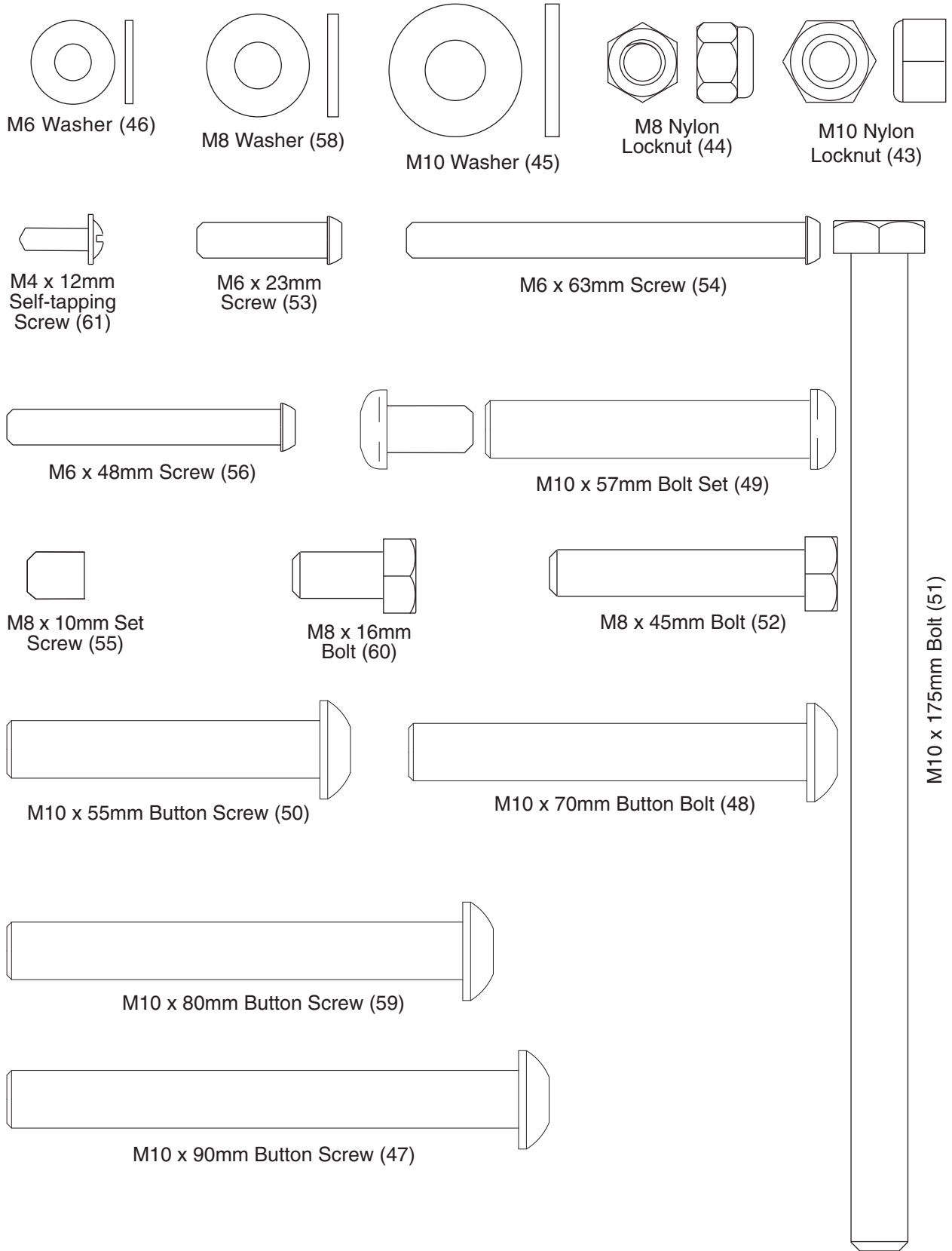

ASSEMBLY

Make Assembly Easier

Everything in this manual is designed to ensure that the weight bench can be assembled successfully by almost anyone. However, the weight bench has many parts and the assembly process will take time. By setting aside plenty of time, assembly will go smoothly.





To hire an authorized service technician to assemble the weight bench, call toll-free 1-800-445-2480.

Before beginning assembly, carefully read the following information and instructions:

- Because of its weight and size, the weight bench should be assembled in the location where it will be used. Make sure that there is enough clearance to walk around the weight bench as you assemble it.
- Place all parts in a cleared area and remove the packing materials. Do not dispose of the packing materials until assembly is completed.

- Tighten all parts as you assemble them, unless instructed to do otherwise.
- As you assemble the weight bench, make sure all parts are oriented as shown in the drawings.
- Assembly requires two persons.
- **For help identifying small parts, use the PART IDENTIFICATION CHART.**

In addition to the included grease, assembly may require the following tools (not included):

- Two adjustable wrenches 
- One rubber mallet 
- One standard screwdriver 
- One Phillips screwdriver 

Assembly may be more convenient if you have a socket set, a set of open-end or closed-end wrenches, or a set of ratchet wrenches.

1. **Before beginning assembly, make sure that you have read and understand the information in the box above. See the PART IDENTIFICATION CHART for help identifying small parts.**

Attach the Support (5) to the Base (1) with an M10 x 55mm Button Screw (50) and two M10 x 80mm Button Screws (59).

Orient the Base Foot (22) with the grooves in the position shown. Attach the Base Foot to the Base (1) with an M4 x 12mm Self-tapping Screw (61).

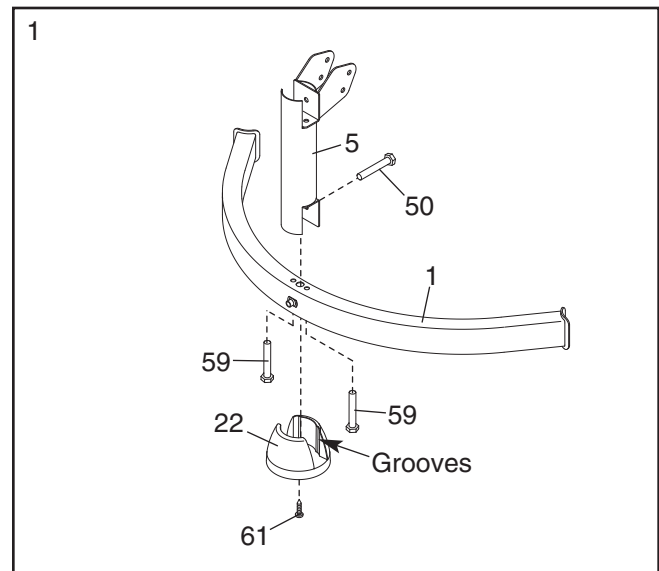

- Orient the Left Upright (6) with the indicated holes facing the direction shown. Attach the Crossbar (4) to the Left Upright with two M10 x 90mm Button Screws (47) and two M10 Washers (45). **Do not tighten the Button Screws yet.**

Attach the Crossbar (4) to the Right Upright (7) with two M10 x 90mm Button Screws (47) and two M10 Washers (45). **Do not tighten the Button Screws yet.**

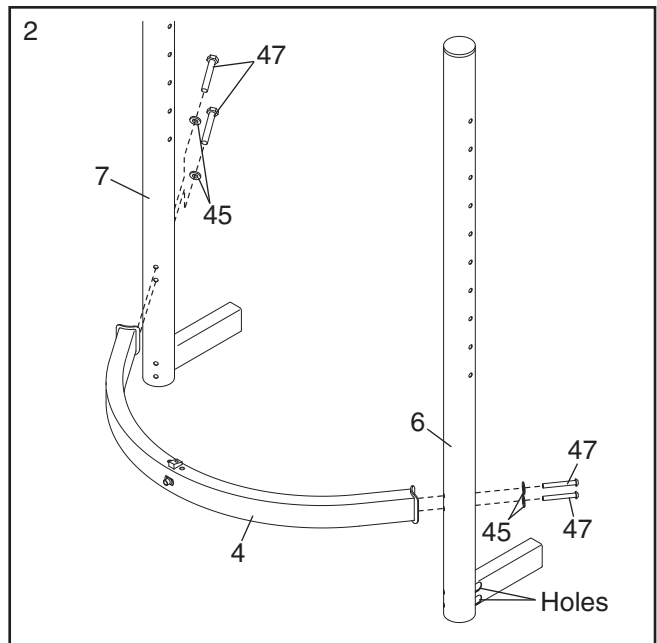

- Attach the Crossbar (4) to the Support (5) with an M10 x 55mm Button Screw (50), two M10 x 80mm Button Screws (59), and two M10 Washers (45). **Do not tighten the Button Screws Yet.**

Attach the Base (1) to the Left and Right Uprights (6, 7) with four M10 x 90mm Button Screws (47) and four M10 Washers (45).

Tighten the Button Screws (47, 50, 59) used in step 2 and this step.

Attach the Left and Right Upright Feet (15, 17) to the Left and Right Uprights (6, 7) with four M4 x 12mm Self-tapping Screws (61).

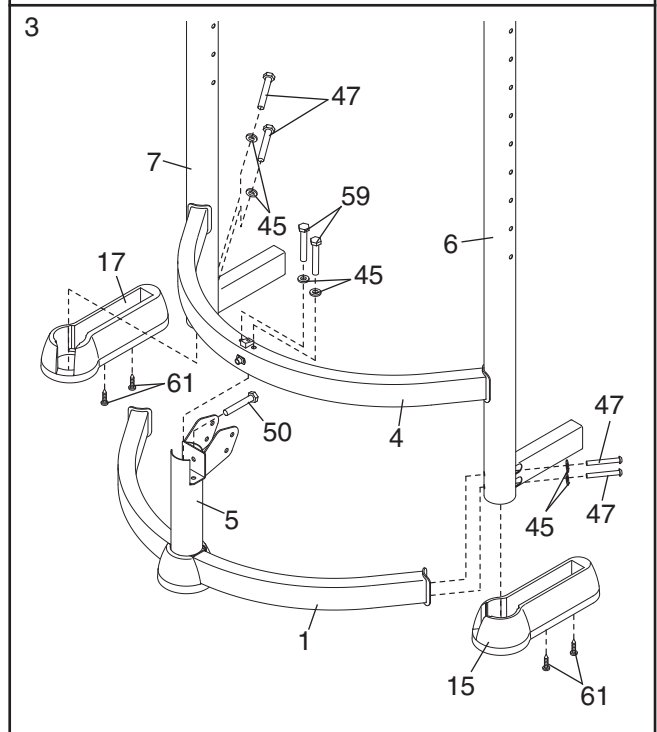

- Orient the Crossbar Cap (21) as shown in the top inset drawing. Press the Crossbar Cap onto the Crossbar (4). Apply a small amount of the included grease to an M10 x 80mm Button Screw (59). Attach the Seat Frame (2) to the Support (5) with the Button Screw and an M10 Nylon Locknut (43).

See the bottom inset drawing and identify the Seat Frame Knob (62). Tighten the Seat Frame Knob into the Seat Frame (2).

Tighten the Backrest Knob (36) into the Seat Frame (2).

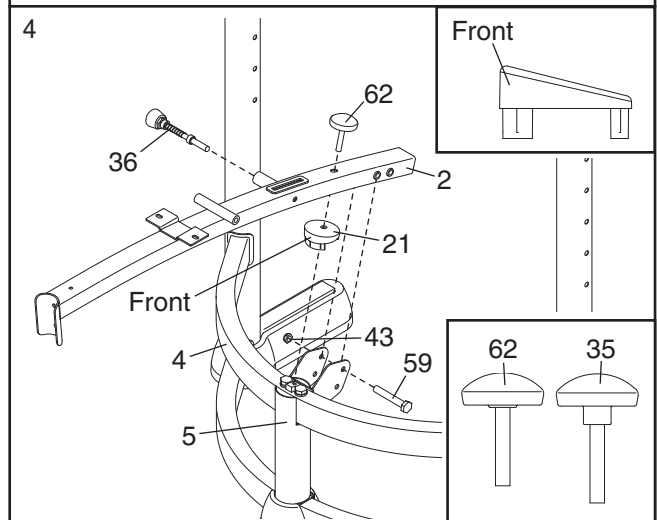

5. **See the inset drawing.** Orient the Front Leg Foot (19) and the Front Leg (3) as shown. Press the Front Leg Foot onto the Front Leg.

Attach the Front Leg Foot (19) to the Front Leg (3) with two M4 x 12mm Self-tapping Screws (61). Next, attach the Front Leg to the Seat Frame (2) with two M10 x 70mm Button Bolts (48), two M10 Washers (45), and an M10 Nylon Locknut (43).

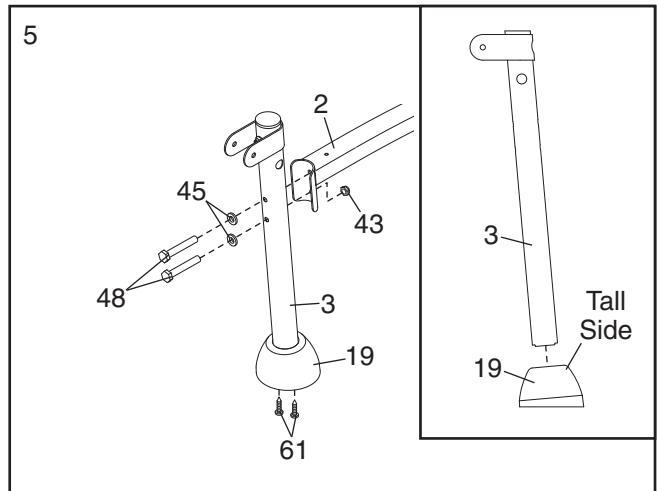

6. Attach the Backrest Bracket (8) to the two Backrest Frames (9) with four M8 x 45mm Bolts (52), four M8 Washers (58), and four M8 Nylon Locknuts (44). **Do not tighten the Nylon Locknuts yet.**

Orient the Backrest (18) with the wide end in the position shown. Attach the Backrest to the Backrest Frames (9) with four M6 x 48mm Screws (56) and four M6 Washers (46). **Do not tighten the Screws yet.**

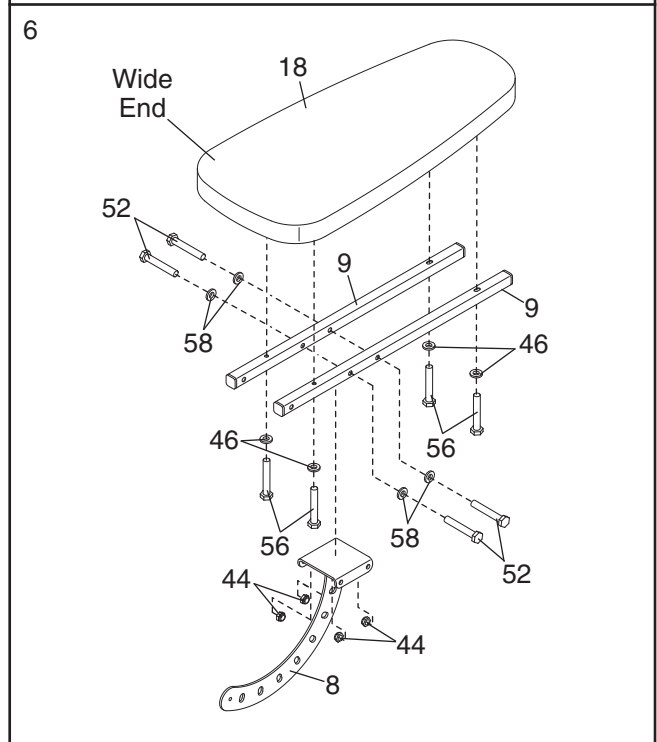

7. Pull the Backrest Knob (36) out as far as it will go. Insert the Backrest Bracket (8) into the slot in the Seat Frame (2). Then, engage the Backrest Knob into the Backrest Bracket.

Apply grease to an M10 x 175mm Bolt (51). Attach the Backrest Frames (9) to the Seat Frame (2) with the Bolt, two M10 Washers (45), and an M10 Nylon Locknut (43). **Do not over-tighten the Nylon Locknut; the Seat Bracket and the Backrest Frames must be able to pivot easily.**

See the inset drawing. Insert an M8 x 16mm Bolt (60) into the Backrest Bracket (8). Tighten an M8 Nylon Locknut (44) onto the Bolt.

Tighten the M8 Nylon Locknuts (44) and the M6 x 48mm Screws (56) used in step 6.

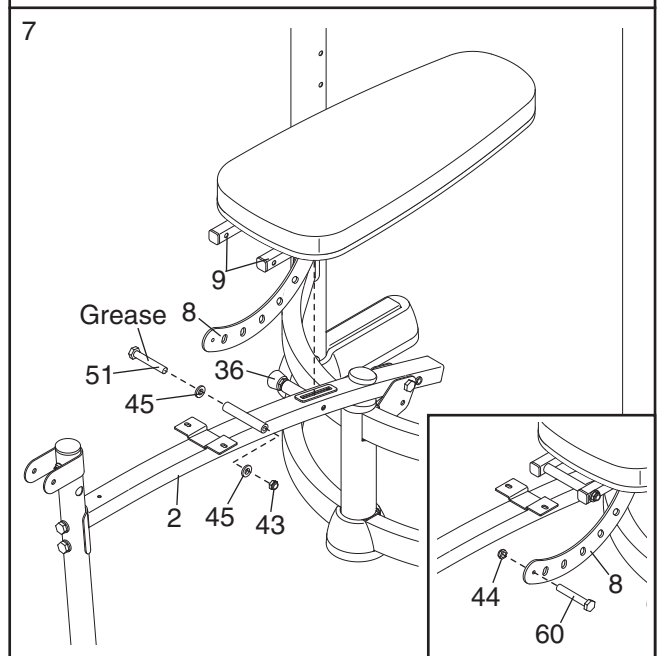

8. Orient the Seat (16) as shown. Attach the Seat to the Seat Frame (2) with two M6 x 23mm Screws (53), an M6 x 63mm Screw (54), and an M6 Washer (46).

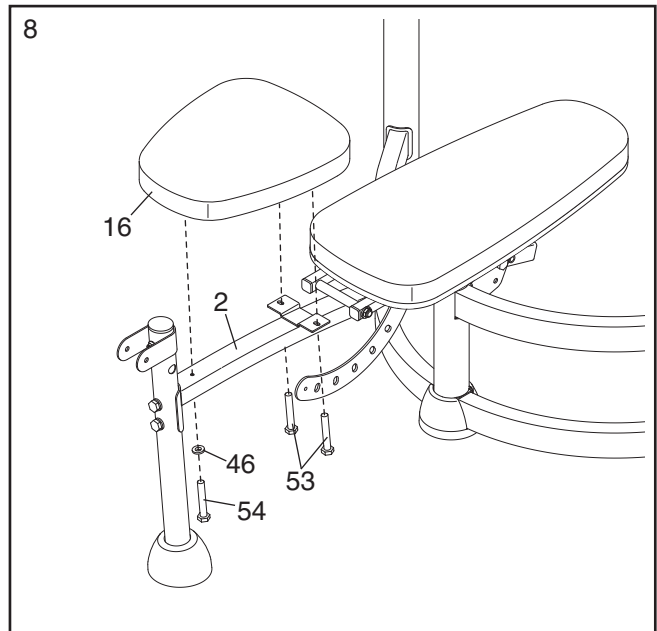

9. Apply grease to the barrel of the M10 x 57mm Bolt Set (49) and to the face of each Bushing (30). Attach the Leg Lever (10) to the Front Leg (3) with the Bolt Set. **Make sure the barrel of the Bolt Set is inserted through both sides of the bracket on the Leg Lever.**

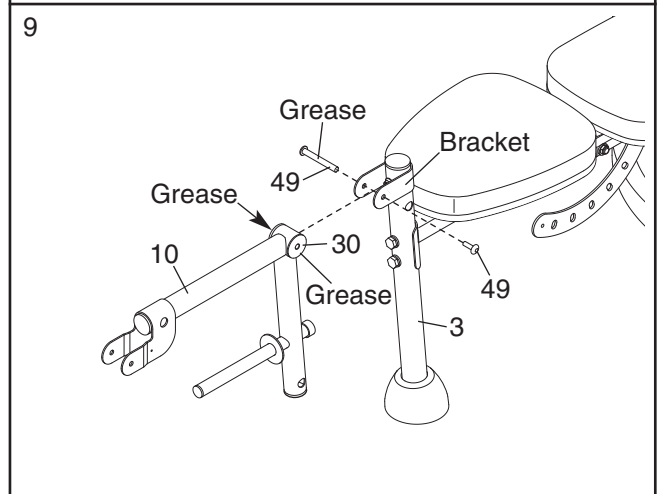

10. Insert a Pad Tube (14) into the Leg Lever (10). Slide a Foam Pad (40) onto each end of the Pad Tube. Then, press a Pad Cap (24) into each Foam Pad.

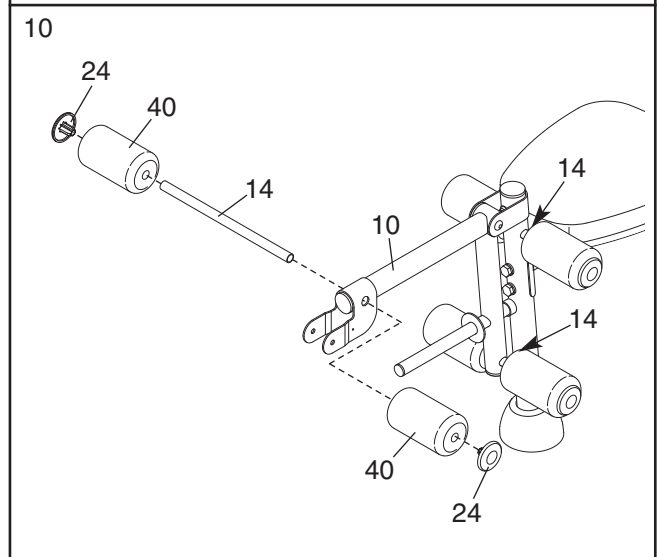

Repeat this step with the other two Pad Tubes (14).

11. Attach the Curl Bumper (39) to the Curl Bar (11) with an M4 x 12mm Self-tapping Screw (61).

See the inset drawing and identify the Curl Pin (38). Attach the Curl Bar (11) to the Leg Lever (10) with the Curl Pin. Attach the Curl Pin to the Leg Lever with an M4 x 12mm Self-tapping Screw (61).

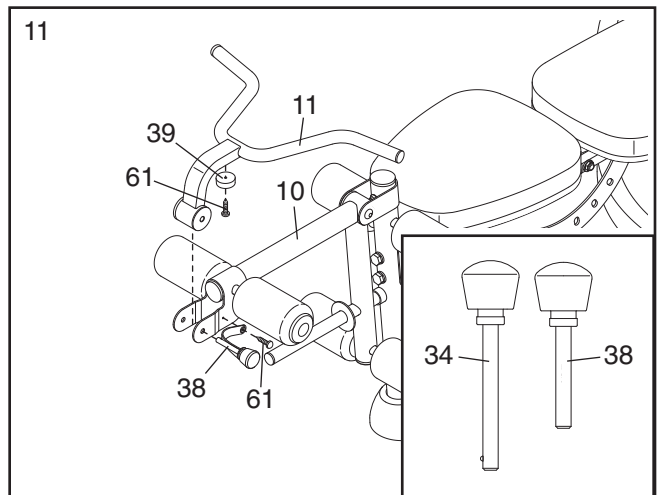

12. **See the inset drawing and identify the Pins (34).**

Slide a Weight Rest (13) onto the Right Upright (7). Insert a Pin (34) through the Weight Rest and the Right Upright. Next, attach the Pin to the Weight Rest with an M4 x 12mm Self-tapping Screw (61).

Repeat this step for the other side of the weight bench.

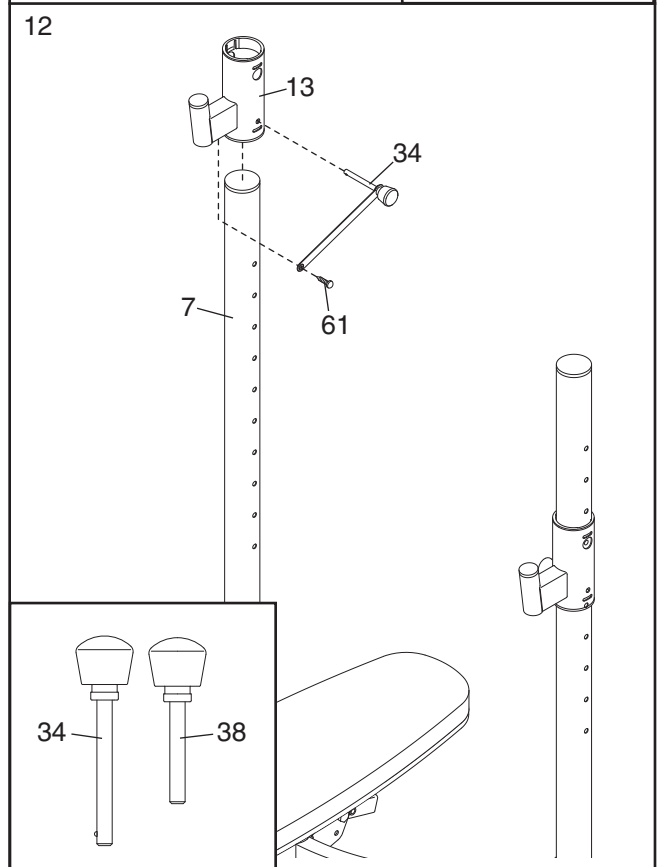

13. Attach the Curl Pad (20) to the Curl Post (12) with two M6 x 23mm Screws (53).

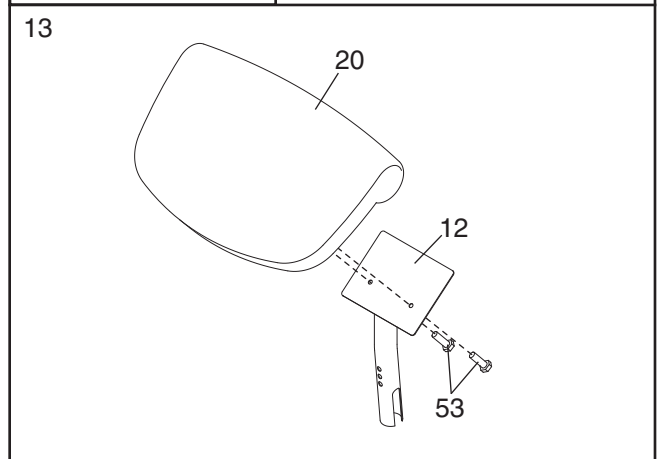

14. Make sure that all parts are properly tightened before the weight bench is used. The use of the remaining parts will be explained in ADJUSTMENTS, beginning on the next page.

ADJUSTMENTS

This section explains how to adjust the weight bench. See the EXERCISE GUIDELINES on page 13 for important information about how to get the most benefit from your exercise program. Also, refer to the accompanying exercise guide to see the correct form for each exercise.

Make sure all parts are properly tightened each time the weight bench is used. Replace any worn parts immediately. The weight bench can be cleaned with a damp cloth and a mild, non-abrasive detergent. Do not use solvents.

ADJUSTING THE BACKREST

To adjust the position of the Backrest (18), pull the Backrest Knob (36) out of the Seat Frame (2) as far as it will go. Raise or lower the Backrest, and reengage the Backrest Knob into the Backrest Bracket (8).

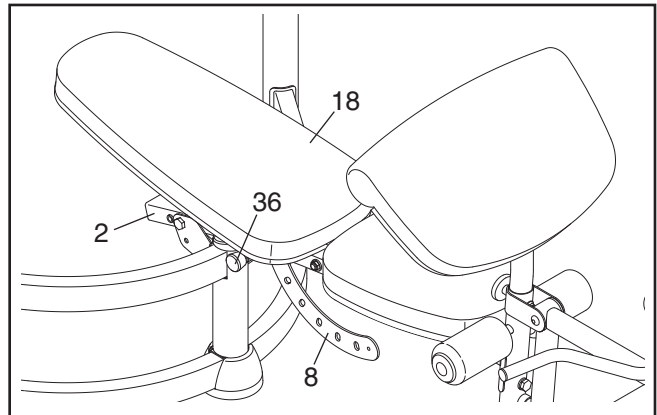

USING THE CURL PAD

To use the Curl Pad (20), remove the indicated 50mm Round Inner Cap (25) and insert the Curl Post (12) into the Front Leg (3). Tighten the Curl Knob (35) into the Front Leg. **Make sure that the Curl Knob passes through a hole in the Curl Post.**

When performing exercises that do not require the Curl Pad (20), remove the Curl Pad and reinsert the 50mm Round Inner Cap (25) into the Front Leg (3).

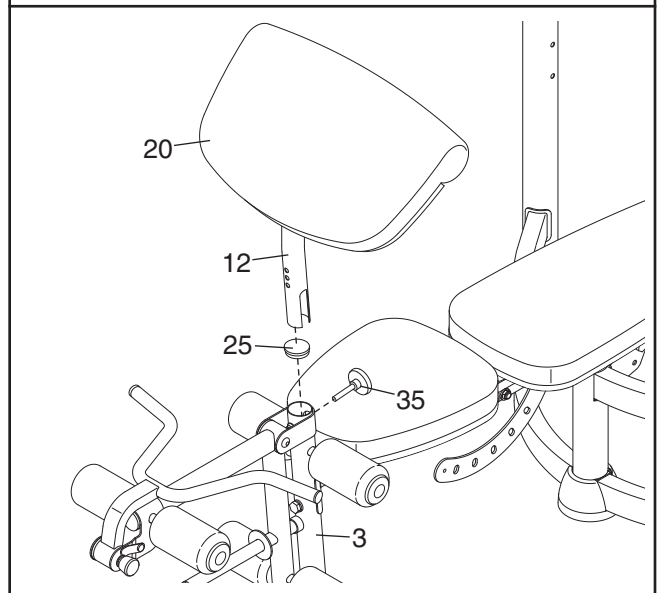

USING THE LEG LEVER

The Leg Lever (10) can be used with standard weights or Olympic weights. To use standard weights, slide a weight plate (not shown) onto the Leg Lever and secure it with a 1" Spring Clip (41).

If you are using Olympic weights, slide the Olympic Adapter (37) onto the Leg Lever (10). Attach the Olympic Adapter with an M8 x 10mm Set Screw (55). Use a 2" Spring Clip (42) to secure the weight plates.

Note: Remove the Curl Bar (11) when using the Leg Lever (10).

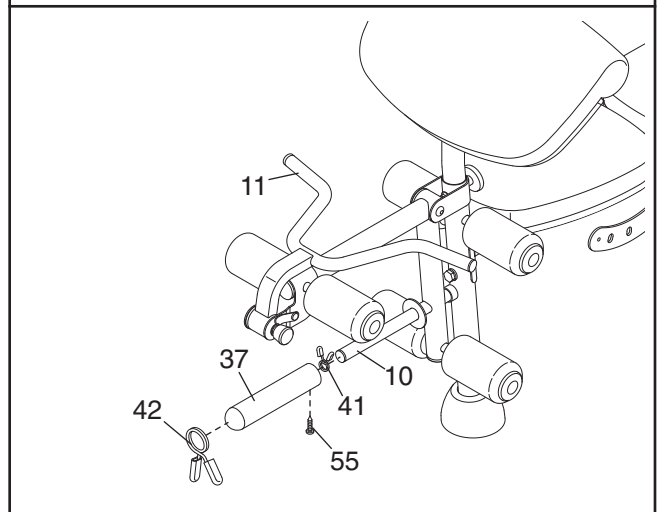

ADJUSTING THE WEIGHT RESTS

To adjust the position of the Weight Rests (13), remove the Pins (34) from the Left and Right Uprights (6, 7). Raise or lower the Weight Rests to the desired position. Reengage the Pins into the Weight Rests and the Left and Right Uprights. **Make sure that the Weight Rests are at the same height.**

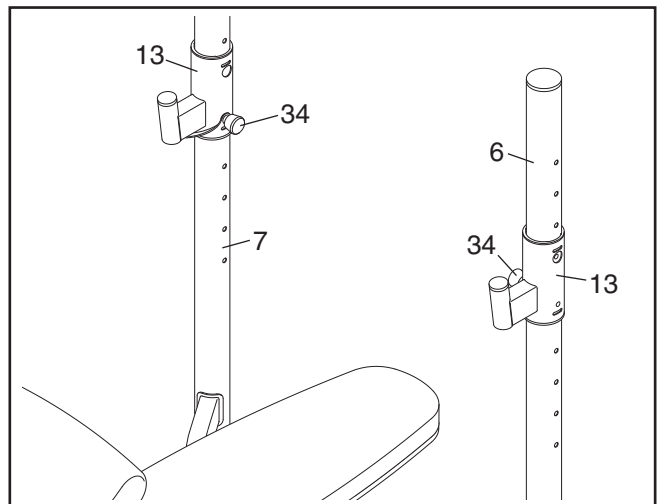

REMOVING THE CURL BAR

To remove the Curl Bar (11), remove the Curl Pin (38) from the Leg Lever (10).

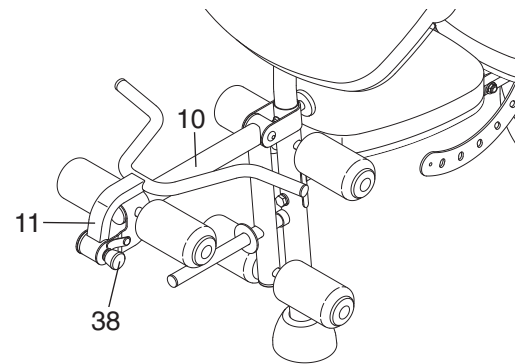

STORING THE WEIGHT BENCH

Remove the Seat Frame Knob (62) from the Seat Frame (2), and lift the weight bench to the position shown. Insert the Seat Frame Knob into the indicated hole in the Support (5) and the Seat Frame. **Make sure that the Seat Frame Knob is inserted through the Seat Frame.**

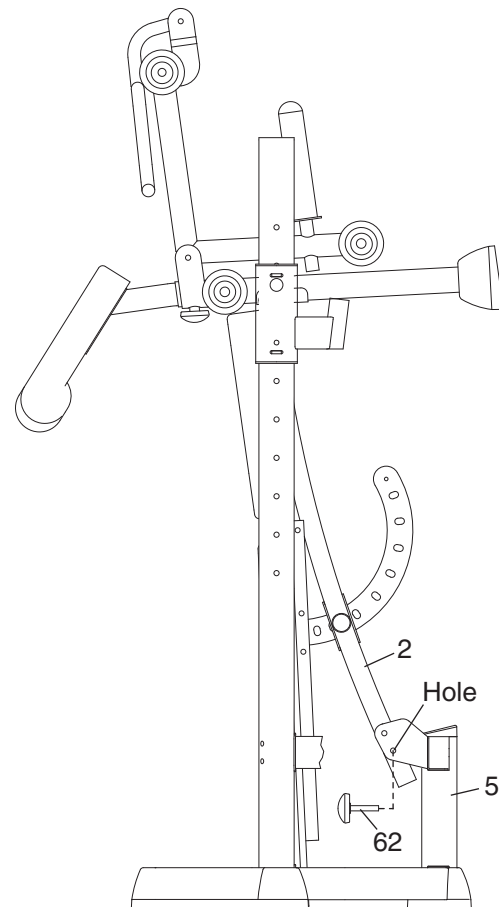

EXERCISE GUIDELINES

THE FOUR BASIC TYPES OF WORKOUTS

Muscle Building

To increase the size and strength of your muscles, push them close to their maximum capacity. Your muscles will continually adapt and grow as you progressively increase the intensity of your exercise. You can adjust the intensity level of an individual exercise in two ways:

- by changing the amount of resistance used
- by changing the number of repetitions or sets performed. (A “repetition” is one complete cycle of an exercise, such as one sit-up. A “set” is a series of repetitions.)

The proper amount of resistance for each exercise depends upon the individual user. You must gauge your limits and select the amount of resistance that is right for you. Begin with 3 sets of 8 repetitions for each exercise you perform. Rest for 3 minutes after each set. When you can complete 3 sets of 12 repetitions without difficulty, increase the amount of resistance.

Toning

You can tone your muscles by pushing them to a moderate percentage of their capacity. Select a moderate amount of resistance and increase the number of repetitions in each set. Complete as many sets of 15 to 20 repetitions as possible without discomfort. Rest for 1 minute after each set. Work your muscles by completing more sets rather than by using high amounts of resistance.

Weight Loss

To lose weight, use a low amount of resistance and increase the number of repetitions in each set. Exercise for 20 to 30 minutes, resting for a maximum of 30 seconds between sets.

Cross Training

Cross training is an efficient way to get a complete and well-balanced fitness program. An example of a balanced program follows:

- Plan strength training workouts on Monday, Wednesday, and Friday.
- Plan 20 to 30 minutes of aerobic exercise, such as running on a treadmill or riding on an elliptical exerciser or exercise cycle, on Tuesday and Thursday.
- Rest from both strength training and aerobic exercise for at least one full day each week to give your body time to regenerate.

The combination of strength training and aerobic exercise will reshape and strengthen your body, plus develop your heart and lungs.

PERSONALIZING YOUR EXERCISE PROGRAM

Determining the exact length of time for each workout, as well as the number of repetitions or sets completed, is an individual matter. It is important to avoid overdoing it during the first few months of your exercise program. You should progress at your own pace and be sensitive to your body’s signals. If you experience pain or dizziness at any time while exercising, stop immediately and begin cooling down. Find out what is wrong before continuing. Remember that adequate rest and a proper diet are important factors in any exercise program.

WARMING UP

Begin each workout with 5 to 10 minutes of stretching and light exercise to warm up. Warming up prepares your body for more strenuous exercise by increasing circulation, raising your body temperature and delivering more oxygen to your muscles.

WORKING OUT

Each workout should include 6 to 10 different exercises. Select exercises for every major muscle group, emphasizing areas that you want to develop most. To give balance and variety to your workouts, vary the exercises from session to session.

Schedule your workouts for the time of day when your energy level is the highest. Each workout should be followed by at least one day of rest. Once you find the schedule that is right for you, stick with it.

EXERCISE FORM

Maintaining proper form is an essential part of an effective exercise program. This requires moving through the full range of motion for each exercise, and moving only the appropriate parts of the body. Exercising in an uncontrolled manner will leave you feeling exhausted. On the exercise guide accompanying this manual you will find photographs showing the correct form for several exercises, and a list of the muscles affected. Refer to the muscle chart on the next page to find the names of the muscles.

The repetitions in each set should be performed smoothly and without pausing. The exertion stage of each repetition should last about half as long as the return stage. Proper breathing is important. Exhale during the exertion stage of each repetition and inhale during the return stroke. Never hold your breath.

Rest for a short period of time after each set. The ideal resting periods are:

- Rest for three minutes after each set for a muscle building workout.
- Rest for one minute after each set for a toning workout.
- Rest for 30 seconds after each set for a weight loss workout.

Plan to spend the first couple of weeks familiarizing yourself with the equipment and learning the proper form for each exercise.

COOLING DOWN

End each workout with 5 to 10 minutes of stretching. Include stretches for both your arms and legs. Move

slowly as you stretch and do not bounce. Ease into each stretch gradually and go only as far as you can without strain. Stretching at the end of each workout is an effective way to increase flexibility.

STAYING MOTIVATED

For motivation, keep a record of each workout. List the date, the exercises performed, the resistance used, and the numbers of sets and repetitions completed. Make copies of the exercise logs found on pages 15 and 16. Use the logs to record your weight and key body measurements at the end of every month.

Remember, the key to achieving the greatest results is to make exercise a regular and enjoyable part of your everyday life.

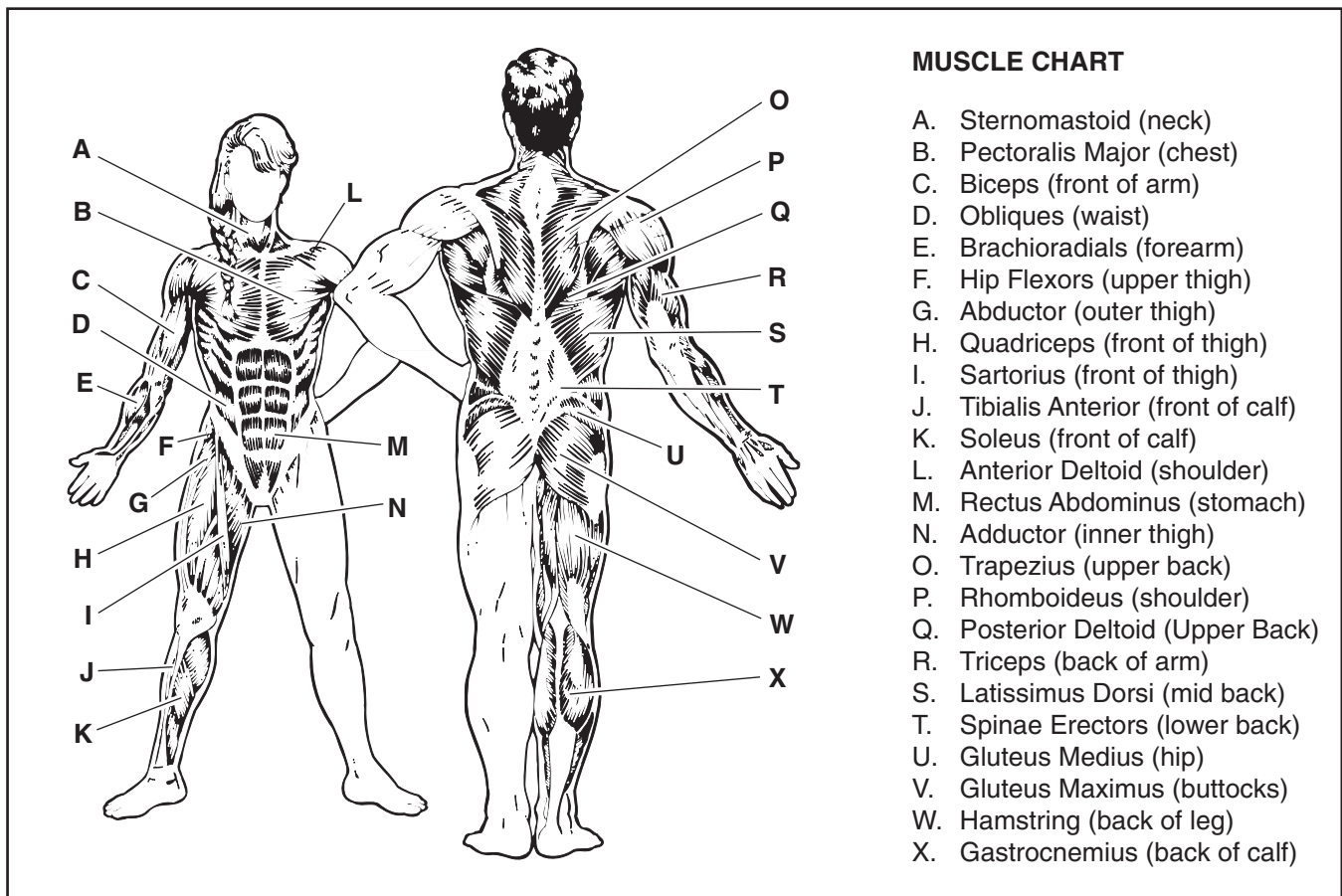

MONDAY	EXERCISE	WEIGHT	SETS	REPS
Date: _____ / _____ / _____				

TUESDAY **AEROBIC EXERCISE**
 Date: _____ / _____ / _____

WEDNESDAY	EXERCISE	WEIGHT	SETS	REPS
Date: _____ / _____ / _____				

THURSDAY **AEROBIC EXERCISE**
 Date: _____ / _____ / _____

FRIDAY	EXERCISE	WEIGHT	SETS	REPS
Date: _____ / _____ / _____				

Make photocopies of this page for scheduling and recording your workouts.

MONDAY	EXERCISE	WEIGHT	SETS	REPS
Date: _____ / _____ / _____				

TUESDAY AEROBIC EXERCISE

Date: _____ / _____ / _____

WEDNESDAY	EXERCISE	WEIGHT	SETS	REPS
Date: _____ / _____ / _____				

THURSDAY AEROBIC EXERCISE

Date: _____ / _____ / _____

FRIDAY	EXERCISE	WEIGHT	SETS	REPS
Date: _____ / _____ / _____				

Make photocopies of this page for scheduling and recording your workouts.

NOTES

PART LIST—Model No. PFBE1516.0

R0606A

Key No.	Qty.	Description	Key No.	Qty.	Description
1	1	Base	35	1	Curl Knob
2	1	Seat Frame	36	1	Backrest Knob
3	1	Front Leg	37	1	Olympic Adapter
4	1	Crossbar	38	1	Curl Pin
5	1	Support	39	1	Curl Bumper
6	1	Left Upright	40	6	Foam Pad
7	1	Right Upright	41	1	1" Spring Clip
8	1	Backrest Bracket	42	1	2" Spring Clip
9	2	Backrest Frame	43	3	M10 Nylon Locknut
10	1	Leg Lever	44	5	M8 Nylon Locknut
11	1	Curl Bar	45	14	M10 Washer
12	1	Curl Post	46	5	M6 Washer
13	2	Weight Rest	47	8	M10 x 90mm Button Screw
14	3	Pad Tube	48	2	M10 x 70mm Button Bolt
15	1	Left Upright Foot	49	1	M10 x 57mm Bolt Set
16	1	Seat	50	2	M10 x 55mm Button Screw
17	1	Right Upright Foot	51	1	M10 x 175mm Bolt
18	1	Backrest	52	4	M8 x 45mm Bolt
19	1	Front Leg Foot	53	4	M6 x 23mm Screw
20	1	Curl Pad	54	1	M6 x 63mm Screw
21	1	Crossbar Cap	55	1	M8 x 10mm Set Screw
22	1	Base Foot	56	4	M6 x 48mm Screw
23	2	70mm Round Inner Cap	57	1	50 x 38mm Inner Cap
24	6	Pad Cap	58	4	M8 Washer
25	1	50mm Round Inner Cap	59	5	M10 x 80mm Button Screw
26	2	45mm Round Inner Cap	60	1	M8 x 16mm Bolt
27	3	25mm Round Inner Cap	61	11	M4 x 12mm Self-tapping Screw
28	1	25mm Round Outer Cap	62	1	Seat Frame Knob
29	1	Olympic Adapter Cap	63	3	Tether
30	4	Bushing	#	1	User's Manual
31	4	38mm Round Inner Cap	#	1	Exercise Guide
32	4	25mm Square Inner Cap	#	4	Hex Key
33	4	Weight Rest Bushing	#	1	Grease Pack
34	2	Pin			

Note: “#” indicates a non-illustrated part. Specifications are subject to change without notice. See the back cover of this manual for information about ordering replacement parts.

EXPLODED DRAWING—Model No. PFBE1516.0

R0606A

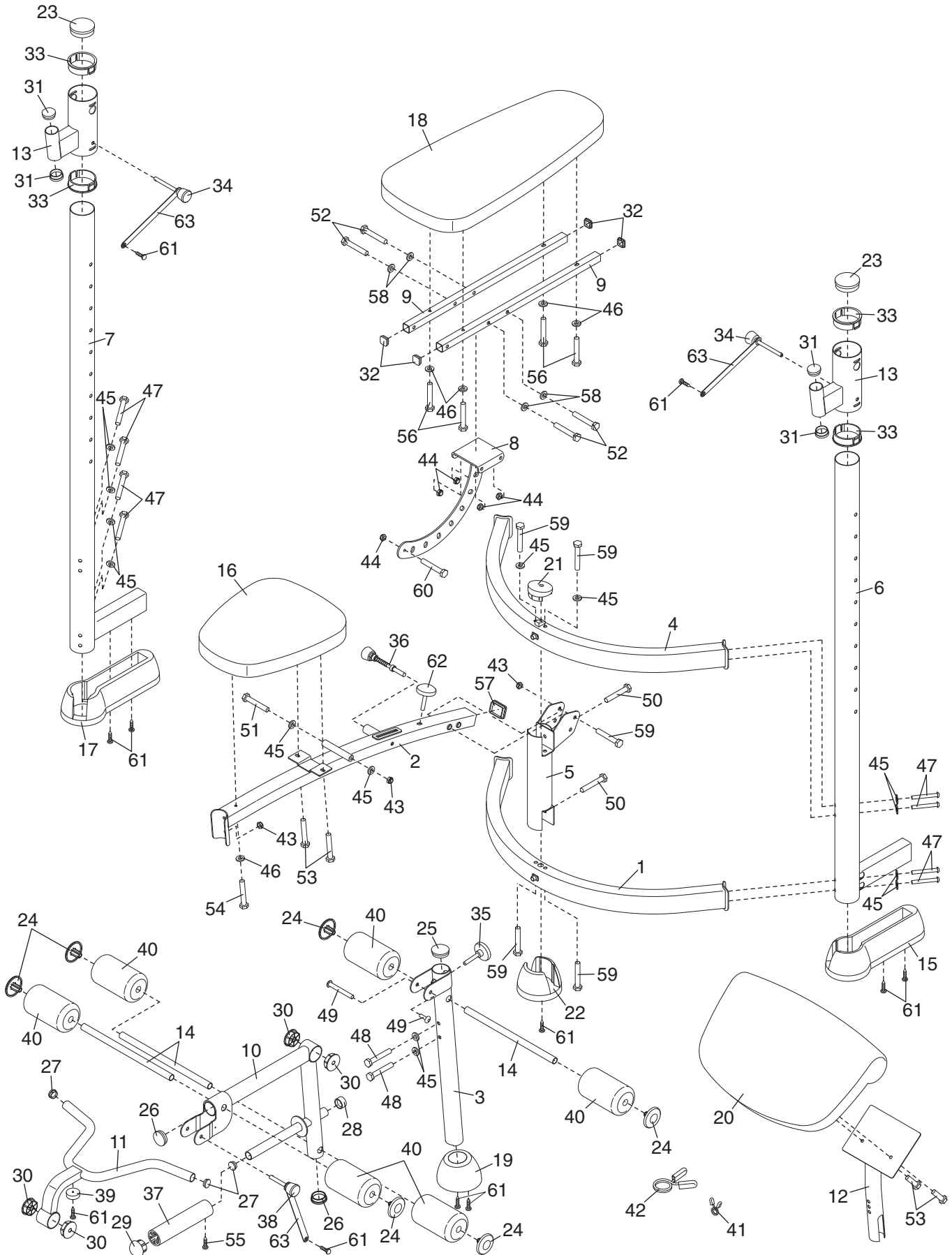

ORDERING REPLACEMENT PARTS

To order replacement parts, please see the front cover of this manual. To help us assist you, please be prepared to give the following information:

- the MODEL NUMBER of the product (PFBE1516.0)
- the NAME of the product (PROFORM FUSION 1.6 X weight bench)
- the SERIAL NUMBER of the product (see the front cover of this manual)
- the KEY NUMBER and DESCRIPTION of the part(s) (see the PART LIST and EXPLODED DRAWING on pages 18 and 19)

LIMITED WARRANTY

ICON Health & Fitness, Inc. (ICON), warrants this product to be free from defects in workmanship and material, under normal use and service conditions, for a period of ninety (90) days from the date of purchase. This warranty extends only to the original purchaser. ICON's obligation under this warranty is limited to replacing or repairing, at ICON's option, the product through one of its authorized service centers. All repairs for which warranty claims are made must be preauthorized by ICON. If the product is shipped to a service center, freight charges to and from the service center will be the customer's responsibility. For in-home service, the customer will be responsible for a minimal trip charge. This warranty does not extend to any product or damage to a product caused by or attributable to freight damage, abuse, misuse, improper or abnormal usage or repairs not provided by an ICON authorized service center; products used for commercial or rental purposes; or products used as store display models. No other warranty beyond that specifically set forth above is authorized by ICON.

ICON is not responsible or liable for indirect, special or consequential damages arising out of or in connection with the use or performance of the product or damages with respect to any economic loss, loss of property, loss of revenues or profits, loss of enjoyment or use, costs of removal or installation or other consequential damages of whatsoever nature. Some states do not allow the exclusion or limitation of incidental or consequential damages. Accordingly, the above limitation may not apply to you.

The warranty extended hereunder is in lieu of any and all other warranties and any implied warranties of merchantability or fitness for a particular purpose is limited in its scope and duration to the terms set forth herein. Some states do not allow limitations on how long an implied warranty lasts. Accordingly, the above limitation may not apply to you.

This warranty gives you specific legal rights. You may also have other rights which vary from state to state.

ICON HEALTH & FITNESS, INC., 1500 S. 1000 W., LOGAN, UT 84321-9813

Free Manuals Download Website

<http://myh66.com>

<http://usermanuals.us>

<http://www.somanuals.com>

<http://www.4manuals.cc>

<http://www.manual-lib.com>

<http://www.404manual.com>

<http://www.luxmanual.com>

<http://aubethermostatmanual.com>

Golf course search by state

<http://golfingnear.com>

Email search by domain

<http://emailbydomain.com>

Auto manuals search

<http://auto.somanuals.com>

TV manuals search

<http://tv.somanuals.com>