

# PRO·FORM<sup>®</sup>

## 660

PATENT PENDING

Model No. PFBE66080

Serial No. \_\_\_\_\_

Write the serial number in the space above for reference.

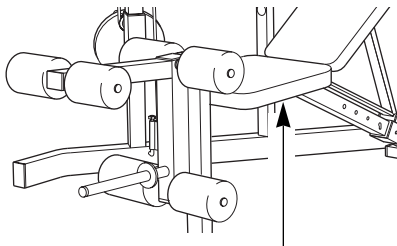

Serial Number Decal (under seat)

## QUESTIONS?

As a manufacturer, we are committed to providing complete customer satisfaction. If you have questions, or find that there are missing or damaged parts, we will guarantee you complete satisfaction through direct assistance from our factory.

**TO AVOID UNNECESSARY DELAYS, PLEASE CALL DIRECT TO OUR TOLL-FREE CUSTOMER HOT LINE.** The trained technicians on our customer hot line will provide immediate assistance, free of charge to you.

**CUSTOMER HOT LINE:**

**1-800-999-3756**

Mon.–Fri., 6 a.m.–6 p.m. MST

## CAUTION

Read all precautions and instructions in this manual before using this equipment. Save this manual for future reference.

## USER'S MANUAL

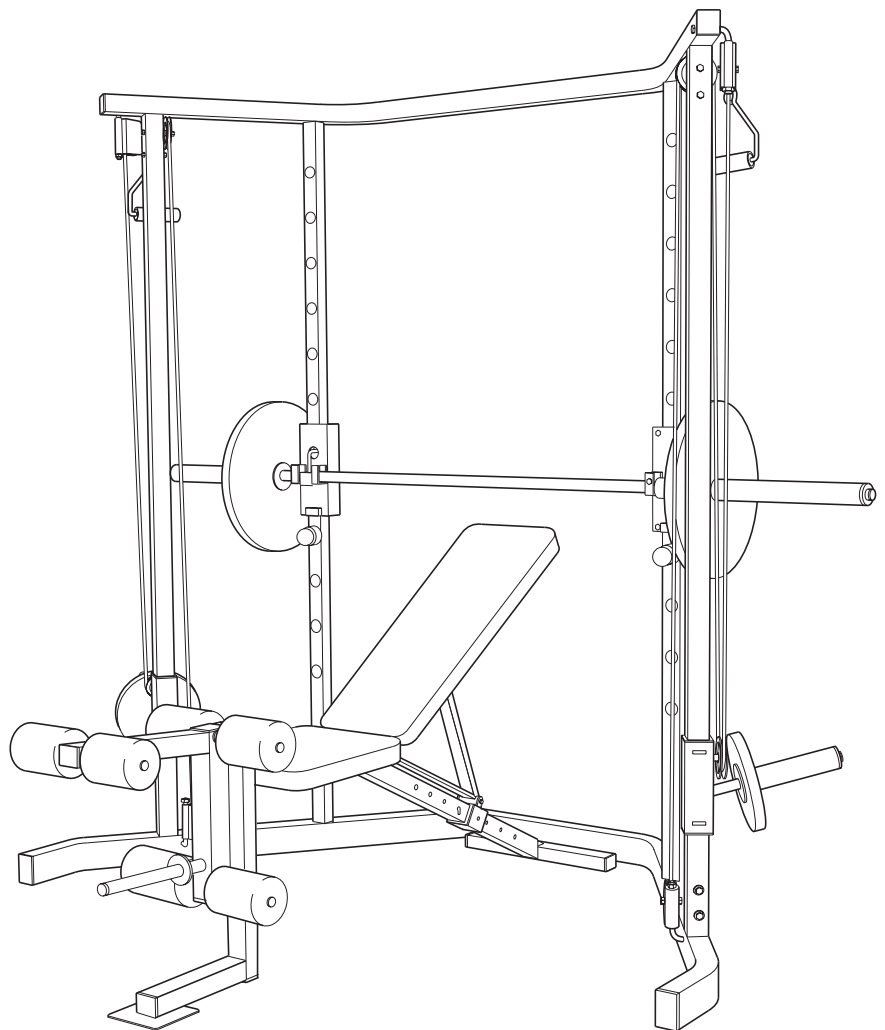

Visit our website at

[www.proform.com](http://www.proform.com)

new products, prizes,  
fitness tips, and much more!

# Table of Contents

|                            |            |
|----------------------------|------------|
| Warning Decal Placement    | 2          |
| Important Precautions      | 3          |
| Before You Begin           | 4          |
| Part Identification Chart  | 5          |
| Assembly                   | 6          |
| Adjusting the Weight Bench | 15         |
| Exercise Guidelines        | 17         |
| Ordering Replacement Parts | Back Cover |
| Limited Warranty           | Back Cover |

Note: A Part List/Exploded Drawing is attached to the center of this manual. Remove the Part List/Exploded Drawing before beginning assembly.

## Warning Decal Placement

The decals shown below have been placed on the weight bench. If a decal is missing, or if it is not legible, please call our Customer Service Department toll-free at 1-800-999-3756, Monday through Friday, 6 a.m. until 6 p.m. Mountain Time, to order a replacement decal. Apply the replacement decal to the location shown.

**! WARNING**

- Misuse of this product may result in serious injury.
- Read user's manual and follow all warnings and operating instructions prior to use.
- Do not allow children on or around machine.
- Replace label if damaged, illegible, or removed.

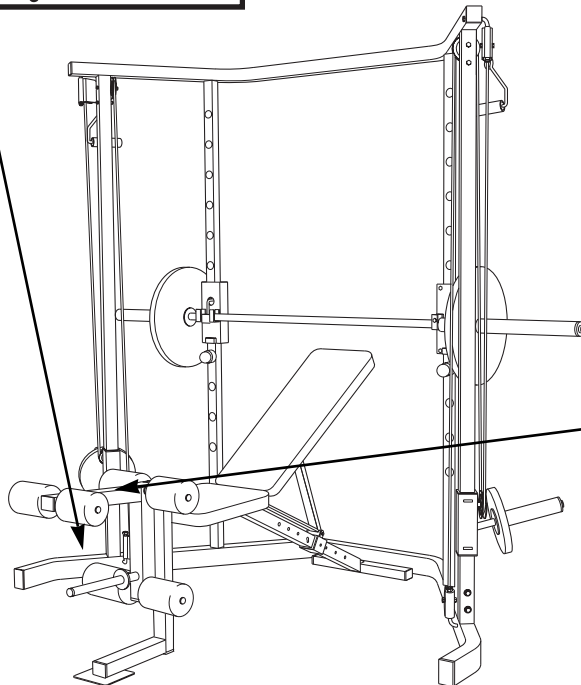

**! WARNING**

- Misuse of this product may result in serious injury.
- Read user's manual and follow all warnings and operating instructions prior to use.
- Do not allow children on or around machine.
- Replace label if damaged, illegible, or removed.

# Important Precautions

**WARNING:** To reduce the risk of serious injury, read the following important precautions before using the weight bench.

1. Read all instructions in this manual before using the weight bench. Use the weight bench only as described in this manual.
2. It is the responsibility of the owner to ensure that all users of the weight bench are adequately informed of all precautions.
3. The weight bench is intended for home use only. Do not use the weight bench in any commercial, rental or institutional setting.
4. Use the weight bench only on a level surface. Cover the floor beneath the weight bench for protection.
5. Inspect and tighten all parts each time you use the weight bench. Replace any worn parts immediately.
6. Keep children under 12 and pets away from the weight bench at all times.
7. Keep hands and feet away from moving parts.
8. Always wear athletic shoes for foot protection while exercising.
9. Always make sure there is an equal amount of weight on each side of your barbell.
10. Always move the bench out of the way when performing squat exercises.
11. The weight bench is designed to support a maximum of 560 pounds, including the user, a barbell and weights. Do not place more than 310 pounds, including the barbell, on the barbell rack. Do not place more than 150 pounds on each weight carriage. Do not place more than 150 pounds on the leg lever for normal use.
12. Make sure that the cables remain on the pulleys at all times. If a cable binds as you are exercising, stop immediately and make sure that the cable is on the pulleys.
13. When performing standing exercises, stand inside the area that is shaded in the drawing on page 4.
14. Always set both safety stops at the same height.
15. Always exercise with a partner. When you are performing bench press exercises, squat exercises or toe raise exercises, your partner should stand behind you to catch the barbell if you cannot complete a repetition.
16. If you feel pain or dizziness at any time while exercising, stop immediately and begin cooling down.

**WARNING:** Before beginning this or any exercise program, consult your physician. This is especially important for persons over the age of 35 or persons with pre-existing health problems. Read all instructions before using. ICON assumes no responsibility for personal injury or property damage sustained by or through the use of this product.

# Before You Begin

Thank you for selecting the versatile PROFORM® 660 Weight Bench. The PROFORM® 660 is designed to help you develop every major muscle group of the body. Whether your goal is a shapely figure, dramatic muscle size and strength or a healthier cardiovascular system, the PROFORM® 660 Weight Bench will help you achieve the specific results you want.

**For your benefit, read this manual carefully before using the PROFORM® 660 Weight Bench.** If you have additional questions, please call our Customer Service Department toll-free at 1-800-999-3756,

Monday through Friday, 6 a.m. until 6 p.m. Mountain Time (excluding holidays). To help us assist you, please note the product model number and serial number before calling. The model number is PFBE66080. The serial number can be found on a decal attached to the PROFORM® 660 Weight Bench (see the front cover of this manual).

Before reading further, please review the drawing below and familiarize yourself with the parts that are labeled.

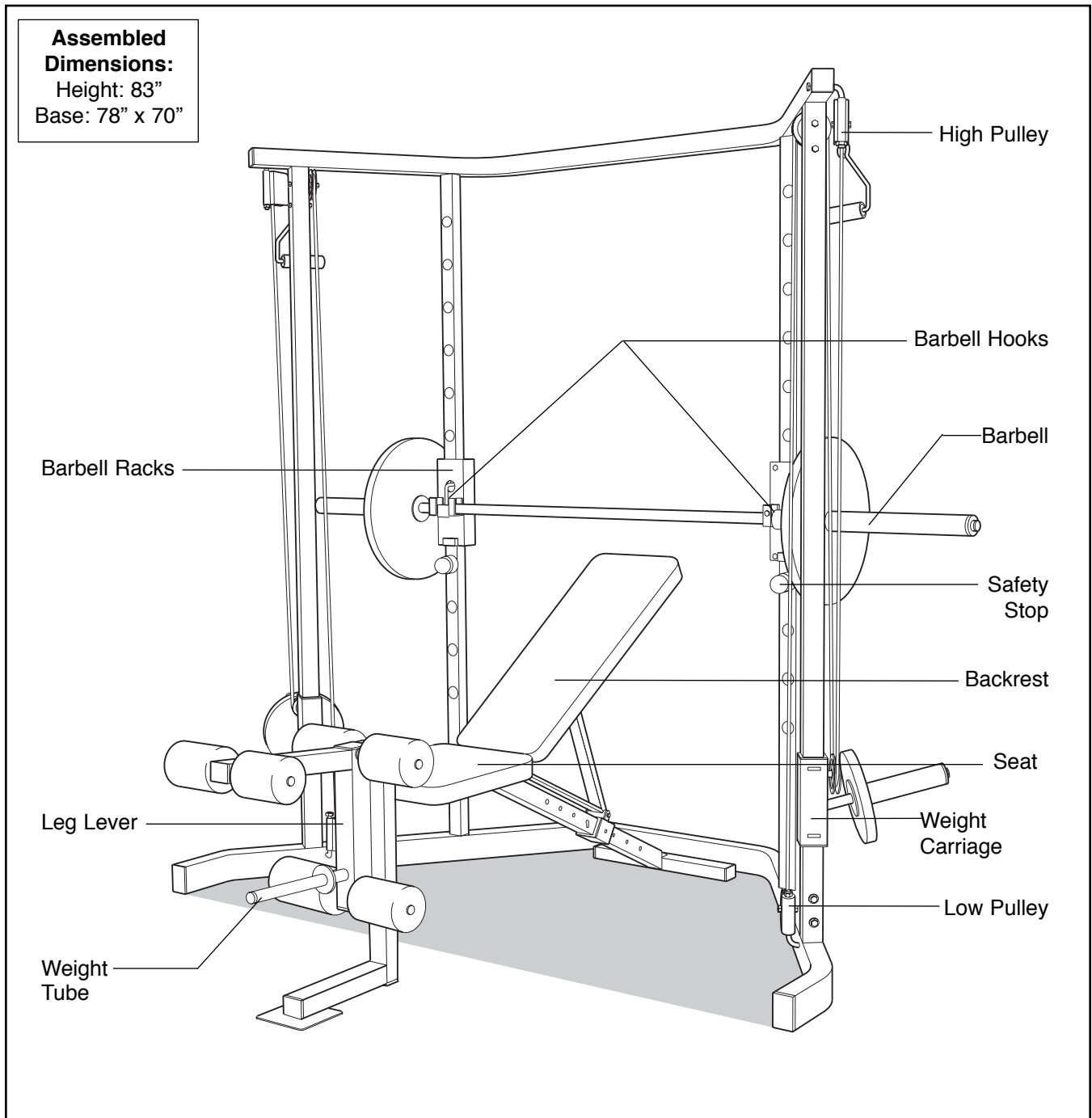

# Part Identification Chart - Model No. PFBE66080

R0200A

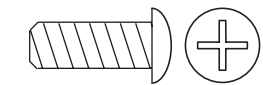

M6 x 16mm Screw (3)

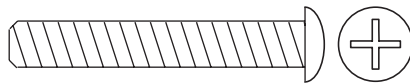

M6 x 38mm Screw (4)



M6 x 32mm Bolt (7)

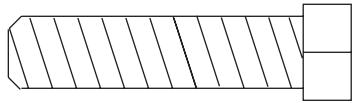

M10 x 39mm Bolt (39)

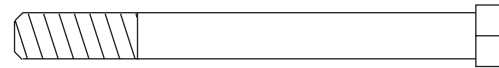

M6 x 61mm Bolt (33)

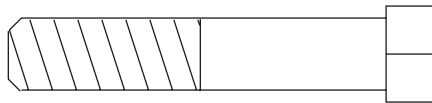

M10 x 50mm Bolt (73)

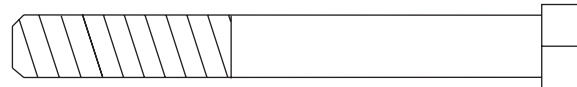

M8 x 70mm Bolt (52)

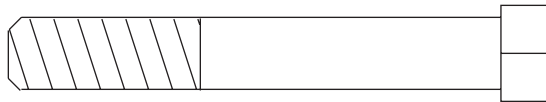

M10 x 65mm Bolt (5)

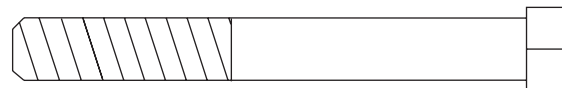

M8 x 68mm Bolt (38)

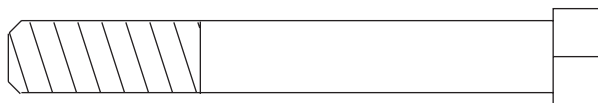

M10 x 72mm Bolt (59)



M8 x 62mm Bolt (58)

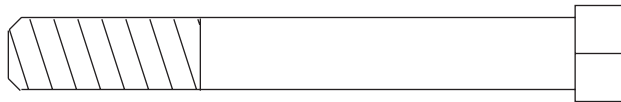

M10 x 75mm Bolt (72)

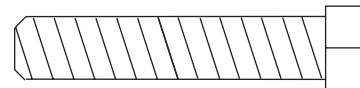

M8 x 41mm Bolt (34)



M10 x 93mm Bolt (43)

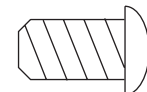

M8 x 14mm Screw (30)

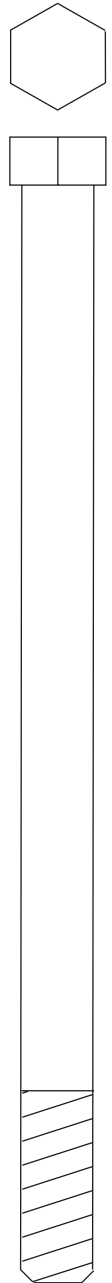

M10 x 145mm Bolt (8)-1

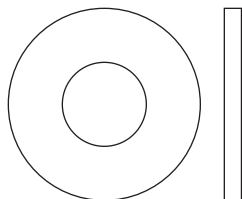

M10 Washer (6)

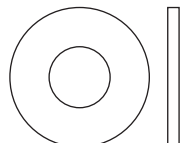

Thin M8 Washer (22)

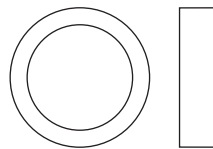

Plastic Washer (21)-4

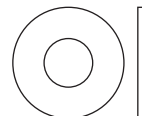

M6 Washer (68)

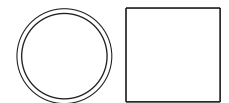

1/2" Spacer (50)



M8 Spacer (66)



M6 Nylon Locknut (2)



M8 Nylon Locknut (13)



M10 Nylon Locknut (1)

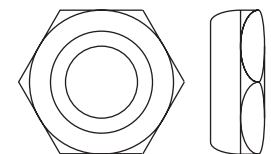

1/2" Nylon Locknut (60)

# Assembly

**Before beginning assembly, carefully read the following information and instructions:**

## Make Things Easier for Yourself!

Everything in this manual is designed to ensure that the assembly of our products can be completed successfully by anyone. However, it is important to recognize that your new equipment is a sophisticated product with many small parts and consequently, the assembly process will take time. Most people find that by setting aside plenty of time, and by deciding to make the task enjoyable, assembly will go smoothly.

- Assembly requires two people.
- Place all parts in a cleared area and remove the packing materials. Do not dispose of the packing materials until assembly is completed.
- Tighten all parts as you assemble them, unless instructed to do otherwise.

• For help identifying the small parts, use the PART IDENTIFICATION CHART on page 5.

• As you assemble the weight bench, make sure all parts are oriented as shown in the drawings.

**The following tools (not included) are required for assembly:**

• **Two (2) adjustable wrenches**

• **One (1) rubber mallet**

• **One (1) standard screwdriver**

• **One (1) phillips screwdriver**

• **Lubricant, such as grease or petroleum jelly plus soapy water.**

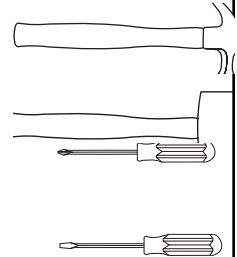

Assembly will be more convenient if you have the following tools: A socket set, a set of open-end or closed-end wrenches or a set of ratchet wrenches.

- 1. Before beginning assembly, make sure you have read and understand the information in the box above.**

Press a 2" Square Inner Cap (17) into each end of the Stabilizer (20). Press a Carriage Bushing (56) into each end of the Decline Carriage (44). Slide the Decline Carriage onto the indicated end of the Frame (54).

Slide the Frame (54) onto the bracket (A) on the Stabilizer (20) and secure it with two M10 x 65mm Bolts (5), four M10 Washers (6) and two M10 Nylon Locknuts (1). **Tighten the Nylon Locknuts until there is no play between the Frame and Stabilizer.**

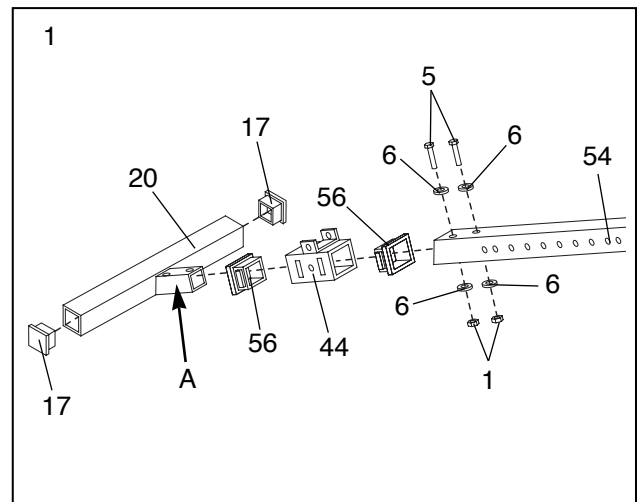

- 2. Press a 2" Square Inner Cap (17) into each of the open ends of the Pad Upright (19).**

Attach the Pad Upright (19) to the Frame (54) with two M8 x 68mm Bolts (38), the Support Plate (16) and two M8 Nylon Locknuts (13).

Attach the Decline Strut (11) to the Decline Carriage (44) with the M10 x 75mm Bolt (72) and an M10 Nylon Locknut (1). **Do not overtighten the Nylon Locknut. You must be able to freely pivot the Decline Strut.**

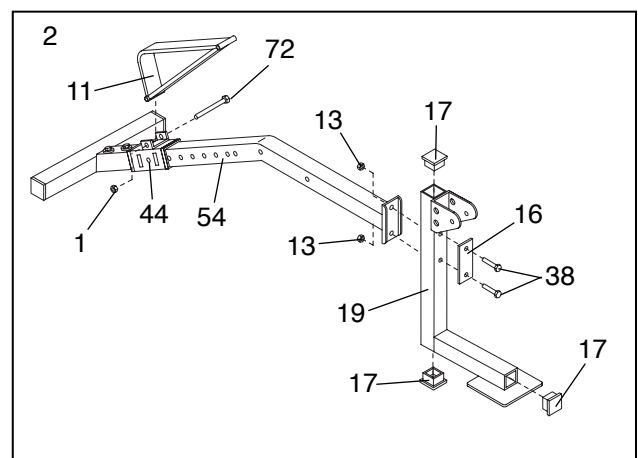

- Press a 1" Square Inner Cap (57) into each end of the two Backrest Tubes (53). Place the Backrest Tubes on the floor, one on each side of the Frame (54). Orient the Backrest Tubes with the indicated holes pointed in the direction shown.

Identify the Right (9) and Left (46) Seat Brackets by looking at the indicated holes. Orient the Seat Brackets as shown in the drawing and place them on the floor on their respective sides of the Frame.

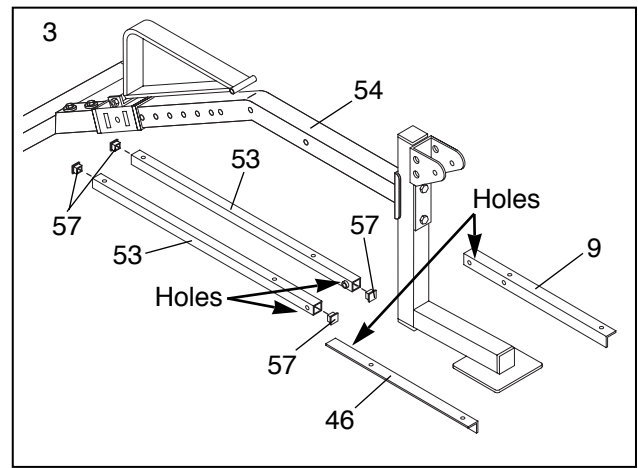

- Lubricate the M10 x 145mm Bolt (8). Push the Bolt through the indicated hole in the Right Seat Bracket (9). Slide a Plastic Washer (21) onto the Bolt.

Push the M10 x 145mm Bolt (8) through the indicated hole in one Backrest Tube (53). Make sure the Backrest Tube is oriented as shown in the drawing. Slide a Plastic Washer (21) onto the M10 x 145mm Bolt (8). Push the Bolt through the indicated hole in the Frame (54).

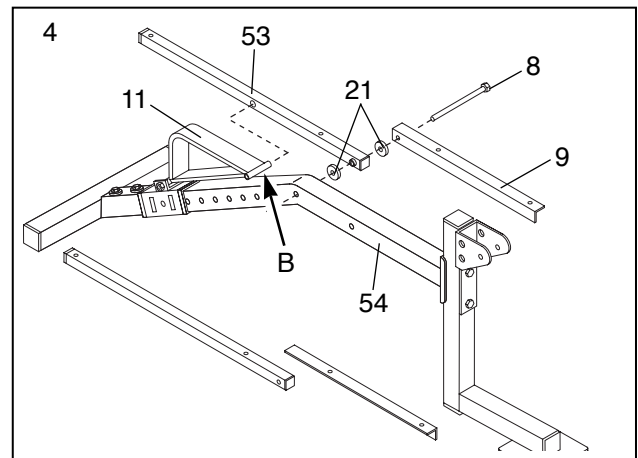

Lift up the Decline Strut (11) and insert the welded rod (B) into the indicated hole in the Backrest Tube (53).

- Slide a Plastic Washer (21) onto the M10 x 145mm Bolt (8). Slide the remaining Backrest Tube (53) over both the Bolt and the welded Rod (B) on the other side of the Decline Strut (11).

Slide a Plastic Washer (21) onto the M10 x 145mm Bolt (8). Slide the Left Seat Bracket (46) onto the Bolt and secure it with an M10 Nylon Locknut (1). **Do not overtighten the Nylon Locknut. You must be able to easily pivot the Seat Brackets and Backrest Tubes.**

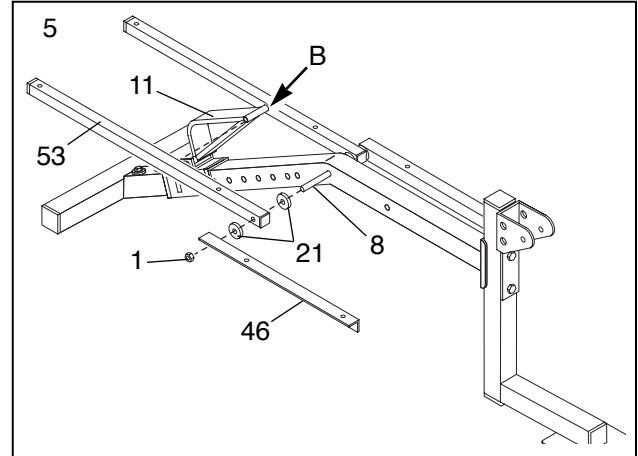

- Attach the Backrest (15) to the Backrest Tubes (53) with four M6 x 38mm Screws (4) and four M6 Washers (68).

Insert the Short "L"-Pin (63) through the hole in the Decline Carriage (44) and the Frame (54).

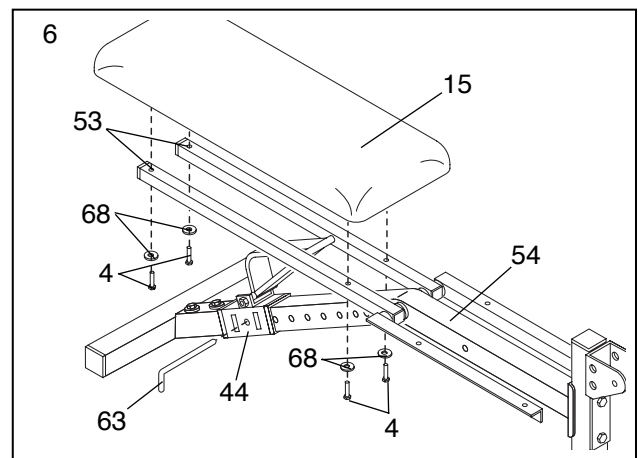

- Attach the Seat (14) to the Seat Brackets (9, 46) with four M6 x 16mm Screws (3) and four M6 Washers (68).

Insert the Long "L"-Pin (71) through the holes in the Seat Brackets (9, 46) and the Frame (54).

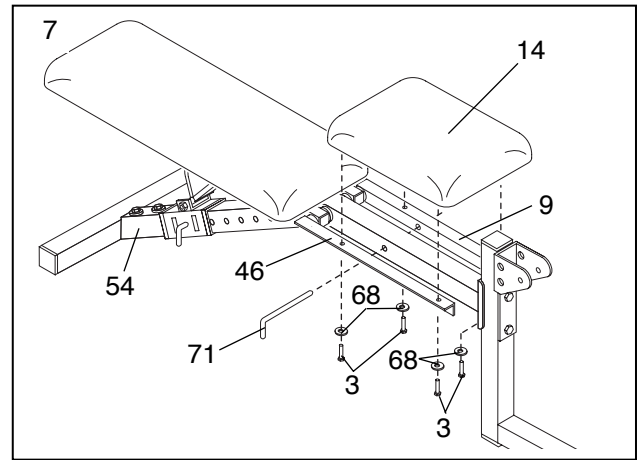

- Press a 2" Square Inner Cap (17) into each of the open ends of the Leg Lever (18).

Slide the Weight Tube (51) into the indicated hole in the Leg lever (18). Secure the Weight Tube with the M8 x 70mm Bolt (52), two Thin M8 Washers (22), a 1/2" Spacer (50) and an M8 Nylon Locknut (13).

Press a 1" Round Inner Cap (12) into the indicated end of the Weight Tube (51). Press the Angle Cap (49) onto the indicated end of the Weight Tube.

Press a Weight Adapter Bushing (47) into each end of a Short Weight Adapter (48). Slide the Weight Adapter onto the Weight Tube (51) and secure it with an M6 x 32mm Bolt (7) and an M6 Nylon Locknut (2). **Note: If you are not going to use olympic weights, you do not need to mount the Weight Adapter.**

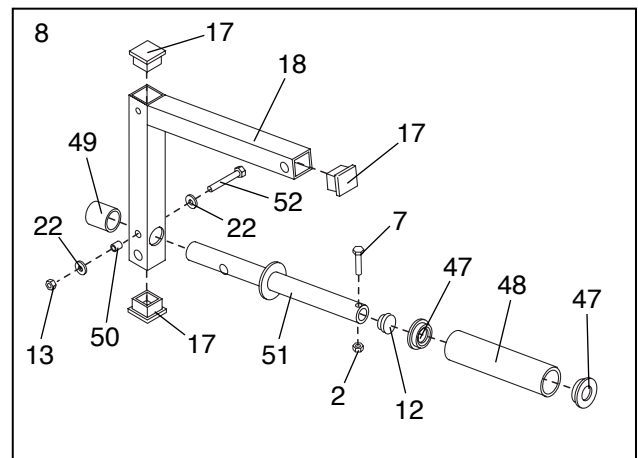

- Attach the Lock (62) to the Pad Upright (19) with the M8 x 62mm Bolt (58), a Thin M8 Washer (22), a Lock Spacer (66) and an M8 Nylon Locknut (13). **Do not overtighten the Nylon Locknut. You must be able to freely pivot the Lock.**

Lubricate the M10 x 72mm Bolt (59). Attach the Leg Lever (18) to the bracket (C) on the Pad Upright (19) with the Bolt and an M10 Nylon Locknut (1). **Do not overtighten the Nylon Locknut. You must be able to freely pivot the Leg Lever.**

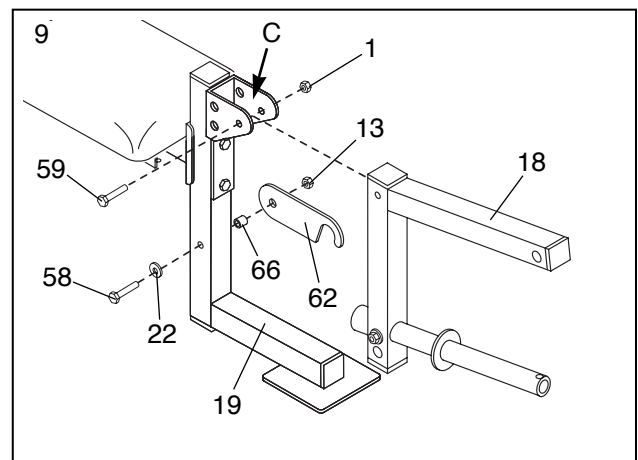

- Press a 3/4" Round Inner Cap (65) into each end of the three Pad Tubes (67, 77).

Insert a Short Pad Tube (67) into the upper hole in the Leg Lever (18) as shown. Slide a Foam Pad onto each end of the Short Pad Tube.

Insert a Long Pad Tube (77) into the lower hole in the Leg Lever (18) as shown. Slide a Foam Pad onto each end of the Long Pad Tube.

Insert a Pad Tube (67) through one of the holes in the bracket (C) on the Pad Upright (19). Slide a 6" Foam Pad (10) onto each end of the Pad Tube.

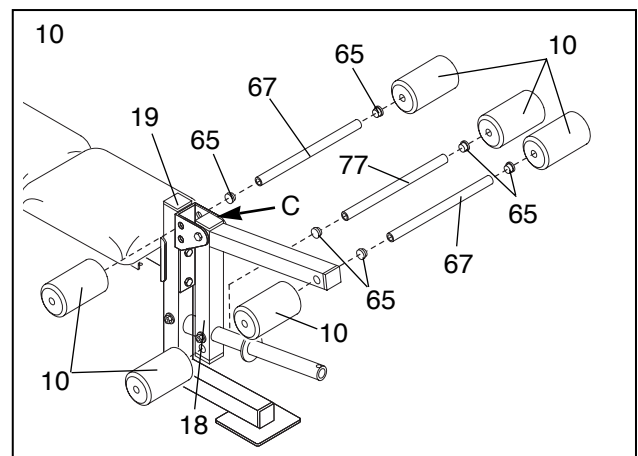



11. Press a 2" Square Inner Cap (17) into the indicated ends of the Right and Left Base (25, 26).

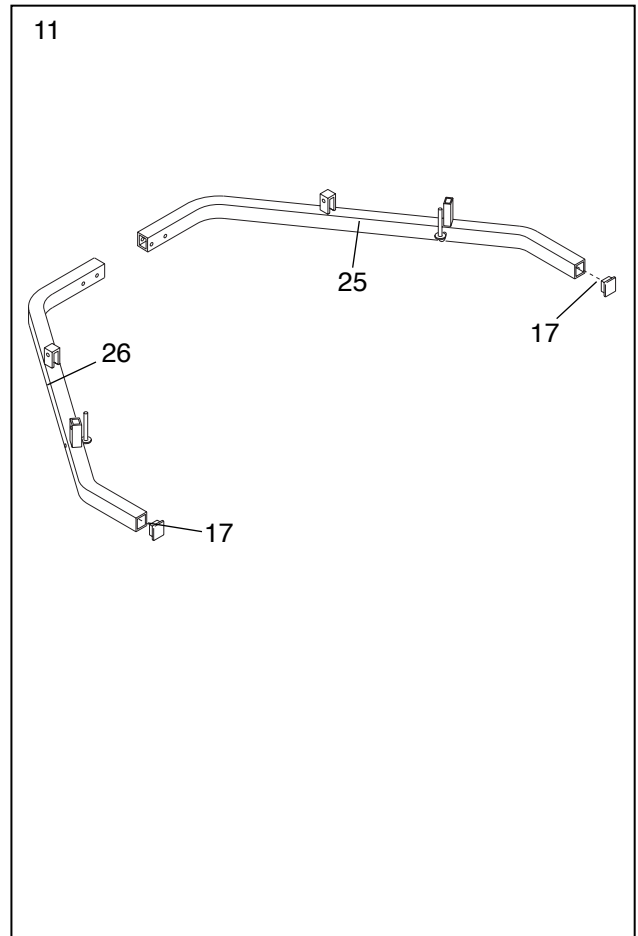

12. Attach the Joiner Bracket (27) to the Right Base (25) with two M10 x 65mm Bolts (5), four M10 Washers (6) and two M10 Nylon Locknuts (1). **Do not tighten the Nylon Locknuts yet.**

Attach the Left Base (26) to the Joiner Bracket (27) with two M10 x 65mm Bolts (5), four M10 Washers (6) and two M10 Nylon Locknuts (1). **Do not tighten the Nylon Locknuts yet.**

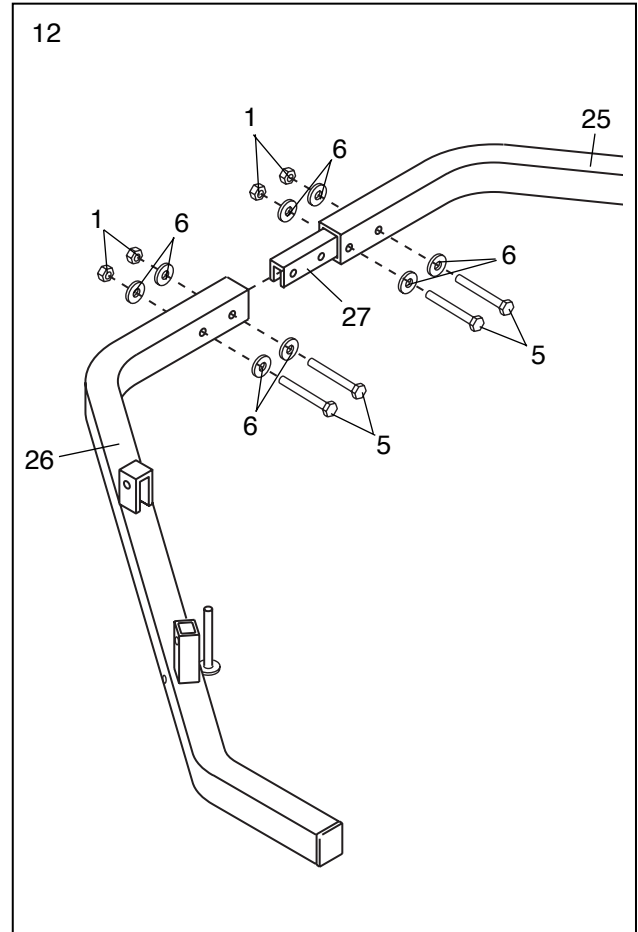

13. Attach a Weight Upright (42) to the bracket (F) on the Right Base (25) with two M10 x 65mm Bolts (5), four M10 Washers (6) and two M10 Nylon Locknuts (1). **Do not tighten the Nylon Locknuts yet.**

Attach a Barbell Upright (41) to the bracket (G) on the Right Base (25) with an M10 x 65mm Bolt (5), two M10 Washers (6) and an M10 Nylon Locknut (1). **Do not tighten the Nylon Locknut yet.**

Repeat the above steps for the Left Base (26, not shown).

**Make sure the Weight Uprights (41, 42) are oriented exactly as shown.**

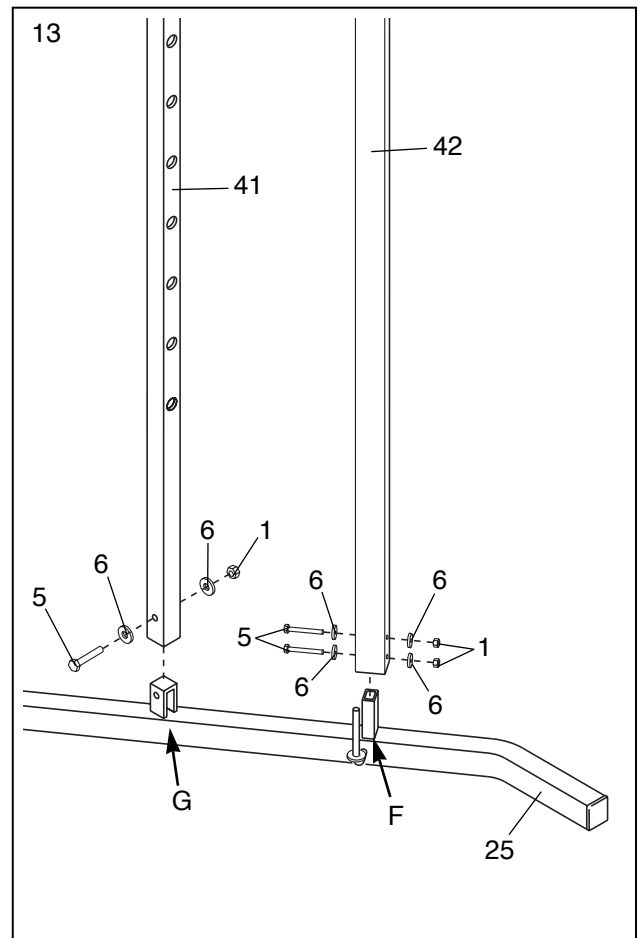

14. Slide a pre-assembled Weight Carriage (37) onto both Weight Uprights (42).

Slide a pre-assembled Barbell Rack (31) onto both Barbell Uprights (41).

**Make sure the Weight Uprights (41, 42) are oriented with the large holes facing inward exactly as shown.**

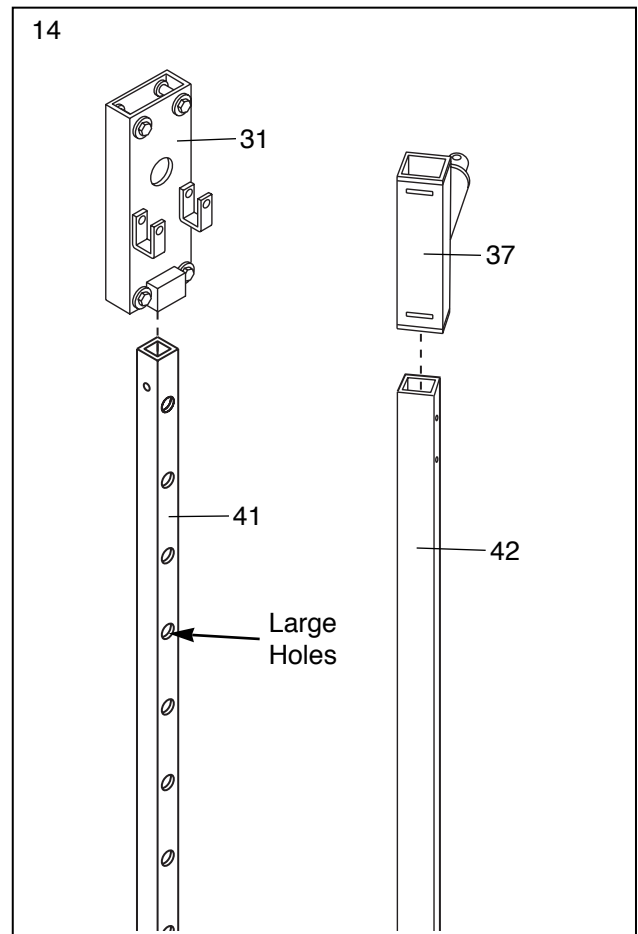

15. Press a 2" Square Inner Cap (17) into each end of the Top Frame (24).

Place the Top Frame (24) on top of the four Uprights (41, 42). **Make sure the mounting brackets on the Top Frame fit into the Uprights.**

Attach the Top Frame (24) to the left Weight Upright (42) with an M10 x 65mm Bolt (5), two M10 Washers (6) and an M10 Nylon Locknut (1). **Make sure the Bolt is mounted in the lower of the two holes, as shown. Do not tighten the Nylon Locknut yet.**

Attach the Top Frame (24) to the left Barbell Upright (41) with an M10 x 65mm Bolt (5), two M10 Washers (6) and an M10 Nylon Locknut (1). **Do not tighten the Nylon Locknut yet.**

Attach the Top Frame (24) to the right Weight Upright (42) and the right Barbell Upright (41) in the same manner. When this is completed, tighten all Nylon Locknuts used in the Base, the Uprights and the Top Frame (see steps 12, 15 and 17).

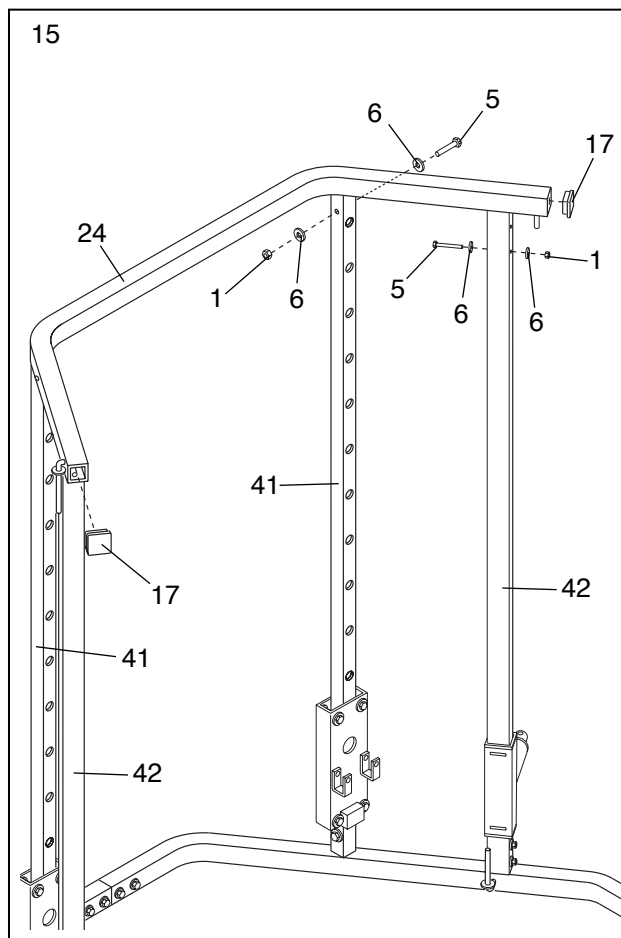

16. Lubricate the welded bolts on the Top Frame (24) and the Right Base (25).

Attach a Pulley Bracket (28) to each of the welded bolts with a 1/2" Nylon Locknut (60). **Note: Make sure the Pulley Brackets are oriented correctly. The Bracket on the Top Frame (24) must have the welded cable trap pointed upwards. The bracket on the Right Base (25) must have the welded cable trap pointed downward.**

**Make sure the Pulley Brackets (28) can be pivoted freely. If not, loosen the Nylon Locknuts (60).**

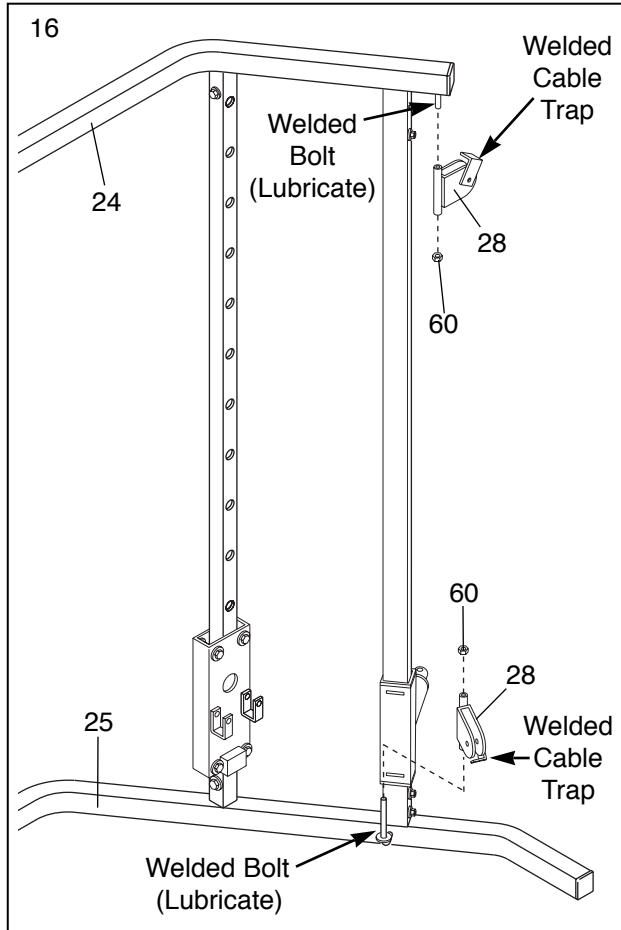

17. Lubricate the welded bolts on the Top Frame (24) and the Left Base (26).

Attach a Pulley Bracket (28) to each of the welded bolts with a 1/2" Nylon Locknut (60). **Note: Make sure the Pulley Brackets are oriented correctly. The Bracket on the Top Frame (24) must have the welded cable trap pointed upwards. The bracket on the Left Base (26) must have the welded cable trap pointed downward.**

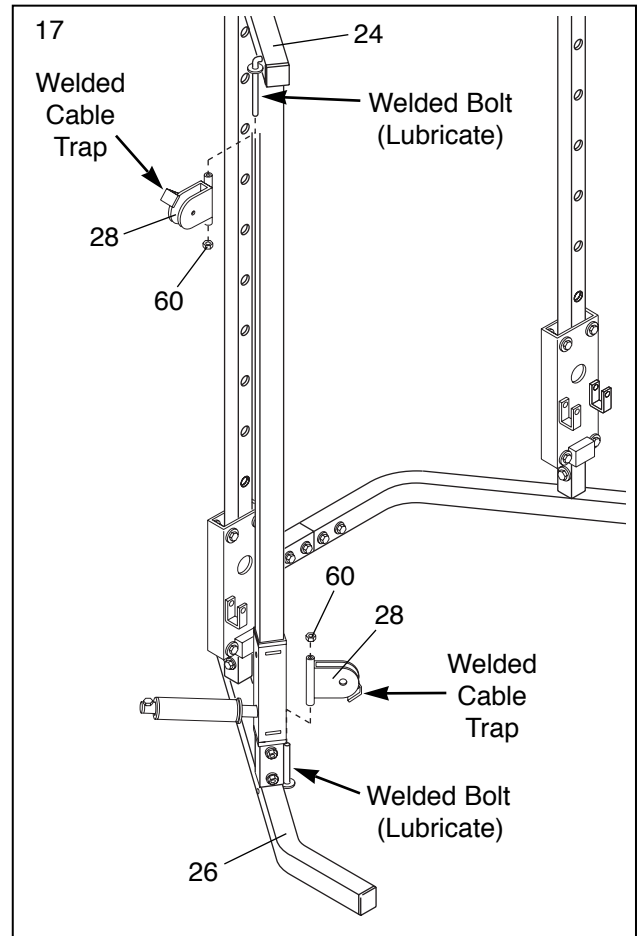

18. Wrap the Cable (45) around a 3 1/2" Pulley (35) in the direction shown. Attach the Pulley to the Pulley Bracket (28) on the Top Frame (24) with an M10 x 50mm Bolt (73) and an M10 Nylon Locknut (1).

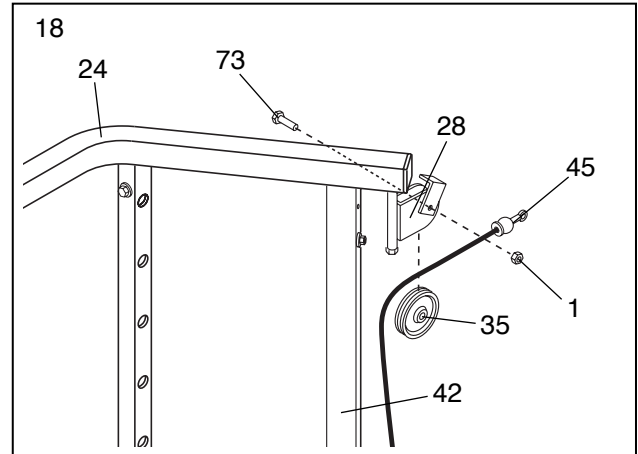

19. Wrap the Cable (45) around a 3 1/2" Pulley (35) in the direction shown. Attach the Pulley and a Cable Trap (40) to the Weight Carriage (37) with an M10 x 39mm Bolt (39). **Make sure the Cable Trap is positioned as shown, so it will hold the Cable in place.**

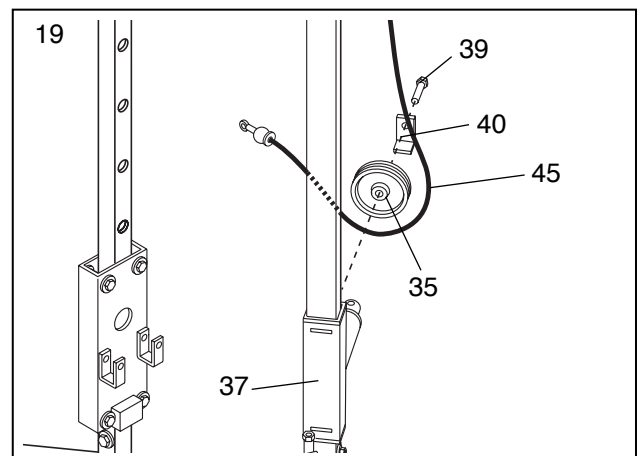

20. Wrap the Cable (45) around a 3 1/2" Pulley (35) in the direction shown. Attach the Pulley to the right Weight Upright (42) with an M10 x 93mm Bolt (43), an M10 Washer (6) and an M10 Nylon Locknut (1). **Make sure the Bolt is mounted in the upper of the two holes, as shown.**

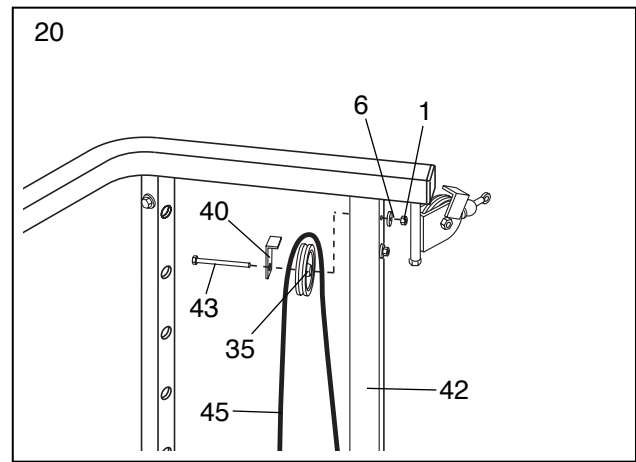

21. Wrap one end of a Cable (45) around a 3 1/2" Pulley (35) in the direction shown. Attach the Pulley to the Pulley Bracket (28) on the Right Base (25) with an M10 x 50mm Bolt (73) and an M10 Nylon Locknut (1).

Make sure the Cable moves smoothly over all Pulleys and that the Weight Carriage can slide freely on the Weight Upright.

Move to the other side of the unit and mount the remaining Cable (45) in the same manner as described in steps 20 to 23.

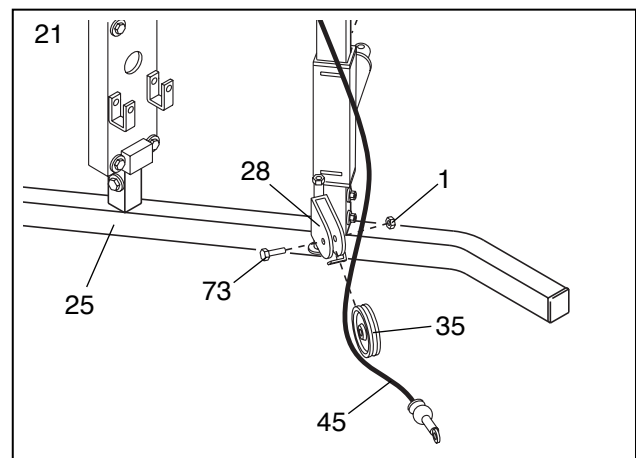

22. Slide one of the Barbell Racks (31) upwards and insert a Safety Stop (23) into the Barbell Upright (41), using the first hole from the bottom. Do the same for the other Barbell Rack.

Place the Barbell (74) in the "U"-brackets (J) on both of the Barbell Racks (31).

Secure the Barbell (74) by tightening two M8 x 41mm Bolts (34) into each Barbell Rack (31).

Attach two Weight Hooks (29) to the Barbell (74) with two M8 x 14mm Screws (30). This is best done by first inserting both Weight Hooks into the holes in the Barbell Racks (31) and Barbell Uprights (41). Then press the U-shaped part of the Weight Hook in place around the Barbell and tighten the Screws with the included allen wrench.

**Make sure the Weight Hooks (29) are positioned so they lock into both Barbell Racks (31) at the same time when you turn the Barbell (74).**

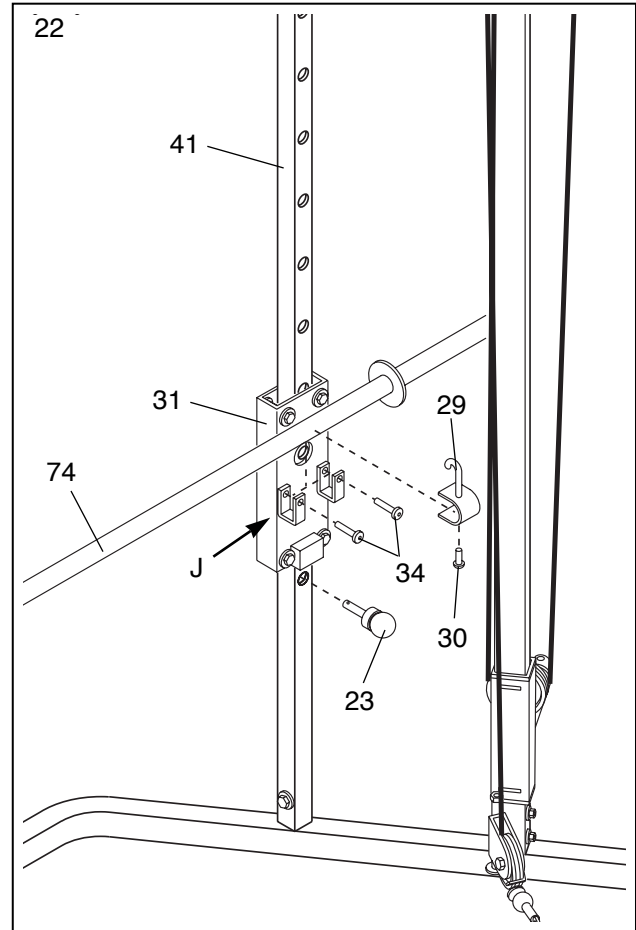

23. Slide a Handle (36) onto a Handle Frame (69) and secure it by tapping a Push Nut (70) onto the end of the Handle Frame.

Repeat this procedure for the second Handle (36).

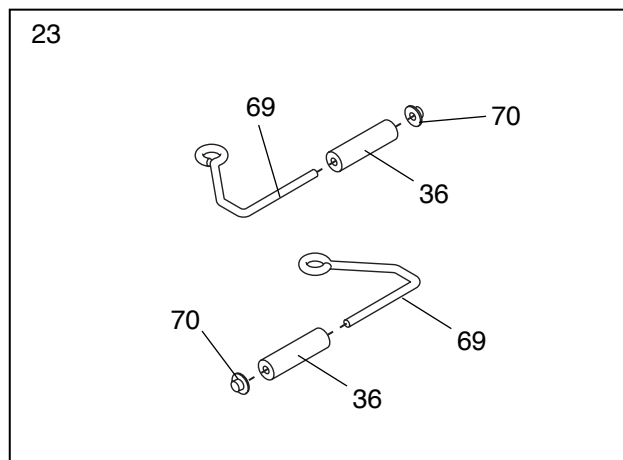

24. Press a Weight Adapter Bushing (47) into each end of the two Barbell Adapters (61).

Slide a Barbell Adapter (61) onto each end of the Barbell (74) and secure them with two M6 x 32mm Bolts (7) and two M6 Nylon Locknuts (2). **Note: If you are not going to use olympic weights, you do not need to mount the Weight Adapter.**

25. **Make sure all parts are properly tightened before you use the weight bench. The use of all remaining parts will be explained in Adjusting the Weight Bench starting on page 15.**

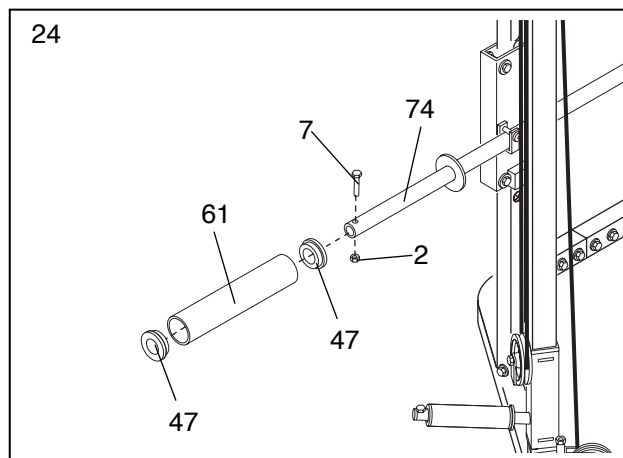

## Adjusting the Weight Bench

This section explains how to adjust the weight bench. See the EXERCISE GUIDELINES on page 17 for important information on how to get the most benefit from your exercise program. Also, refer to the accompanying exercise poster to see the correct form for each exercise.

Inspect and tighten all parts each time you use the weight bench. Replace any worn parts immediately. The weight bench can be cleaned with a damp cloth and a mild, non-abrasive detergent. Do not use solvents.

### USING THE BARBELL RACKS

Before beginning an exercise, move the Safety Stops (23) to a set of holes in the Barbell Uprights (41) that is best suited for that exercise. The selected holes should represent the lowest point to which you want your Barbell (74) to go during the exercise. Rotate your Barbell until the Barbell Hooks (29) disengage from the Barbell Uprights. Perform the exercise as shown in the accompanying EXERCISE GUIDE. When you have completed the exercise, rotate your barbell until the Barbell Hooks lock into a set of holes in the Barbell Uprights.

**WARNING: Always set both safety stops at the same height. Always make sure the barbell hooks lock into holes in the Uprights at the same height. To do this, make sure your barbell is in a level position before you try to engage the barbell hooks.**

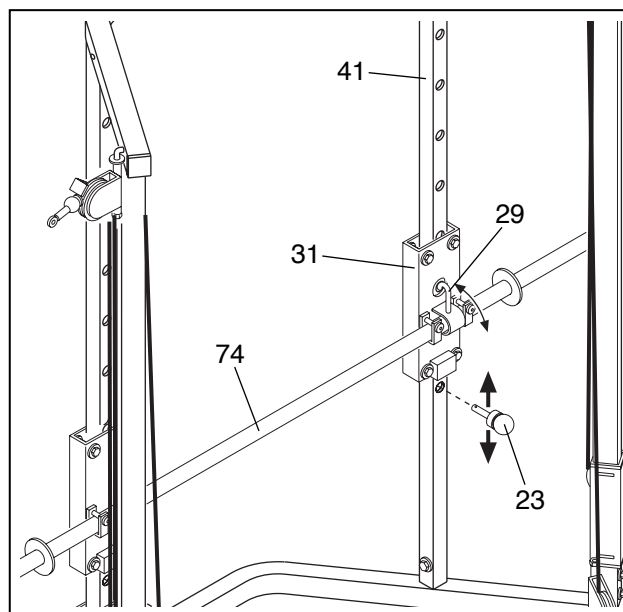

## ADJUSTING THE SEAT INCLINE

Some exercises can be performed more comfortably when the Seat (14) has a slight incline. To give the Seat an incline, pull out the Long “L”-Pin (71). Lift up the end of the Seat and insert the “L”-Pin through the holes in the Seat Brackets (9, 46), but not through the holes in the Frame (54). Then lower the Seat again.

To remove the incline, pull out the “L”-Pin (71), lower the Seat (14) and re-insert the pin through the holes in both the Seat Brackets (9, 46) and the Frame (54).

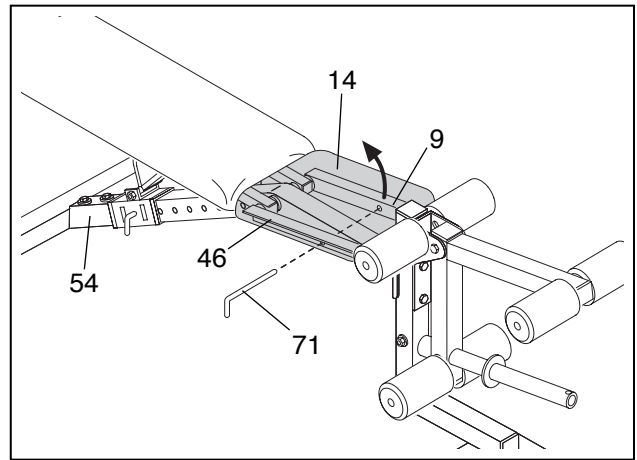

## LOCKING THE LEG LEVER

Some exercises, such as sit-ups, can be performed more comfortably with the Leg Lever (18) locked.

To lock the Leg Lever (18), turn the Lock (62) until it engages the Long Pad Tube (77).

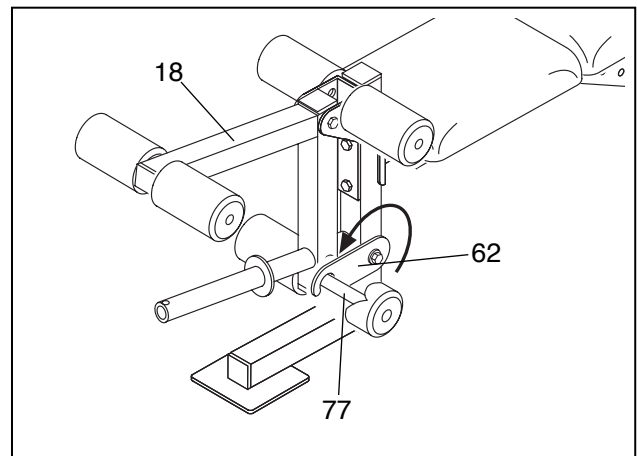

## ADJUSTING THE BACKREST

The Backrest (15) can be adjusted to a level position and several decline and incline positions.

To change the position of the Backrest (15), pull out the Short “L”-Pin (63). Raise or lower the Backrest to the desired position and re-insert the “L”-Pin.

**WARNING: Always insert the “L”-pin before putting any weight on the backrest.**

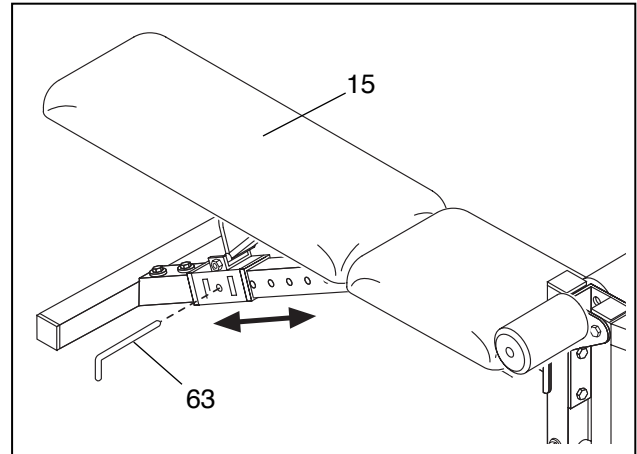

## ATTACHING WEIGHTS TO THE LEG LEVER

To use the Leg Lever (18), slide the desired amount of weight (not included) onto the weight post. If you are using olympic weights, you will need to use a Weight Adapter (48). See assembly step 8 for instructions on attaching the Weight Adapter.

**WARNING: Do not place more than 150 pounds on the leg lever.**

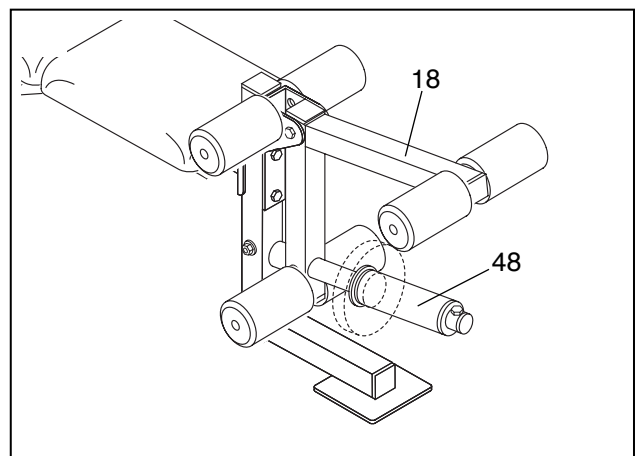

## ATTACHING WEIGHTS TO THE WEIGHT CARRIAGES

To use the upper or lower pulley stations, slide the desired amount of weight (not included) onto the weight tube of one of the Weight Carriages (37). If you are using olympic weights, you will need to use a Weight Adapter (48). See assembly step 13 for instructions.

If the exercise you are performing requires both Weight Carriages (37), **make sure there is an equal amount of weight on both Weight Carriages.**

**WARNING: Do not place more than 150 pounds on each weight carriage.**

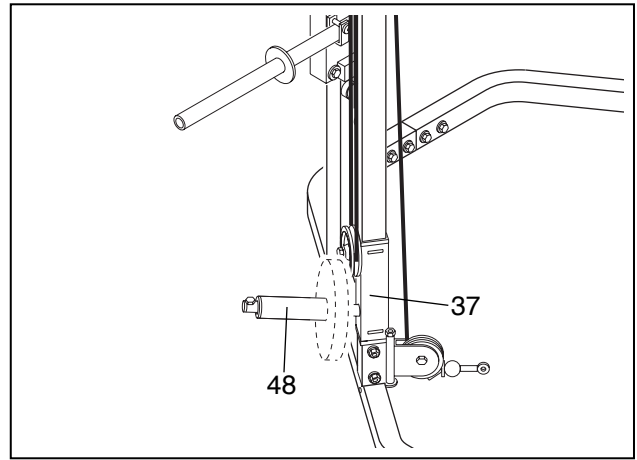

## ATTACHING THE HANDLES TO THE UPPER AND LOWER PULLEY STATIONS

To use the upper pulley station (see drawing A) or lower pulley station (see drawing B), weight must first be placed on the weight carriages (see ATTACHING WEIGHTS TO THE WEIGHT CARRIAGES above).

The Handles (36) can be attached to the Cables (45) with the Cable Clips (64) as shown.

The Ankle Strap (55) can be attached to the Cables (45) in the same manner.

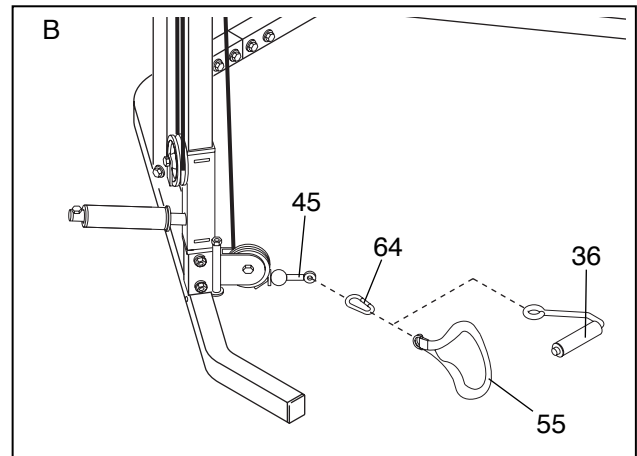
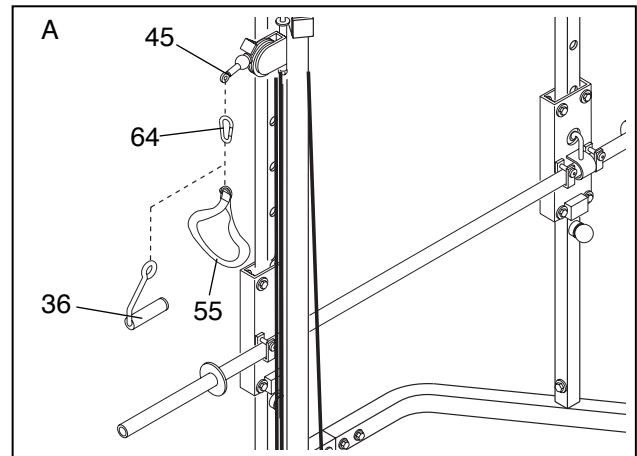

## SECURING WEIGHTS WITH THE SPRING CLIPS

When you have attached weights (not included) to the Barbell (74), Weight Carriages (37) or Leg Lever (18, not shown), always secure them with a Spring Clip (76) or 1" Spring Clip (78).

**Note: The Spring Clips (76) are for use with olympic weights and the 1" Spring Clips (78) are for use with regular weights.**

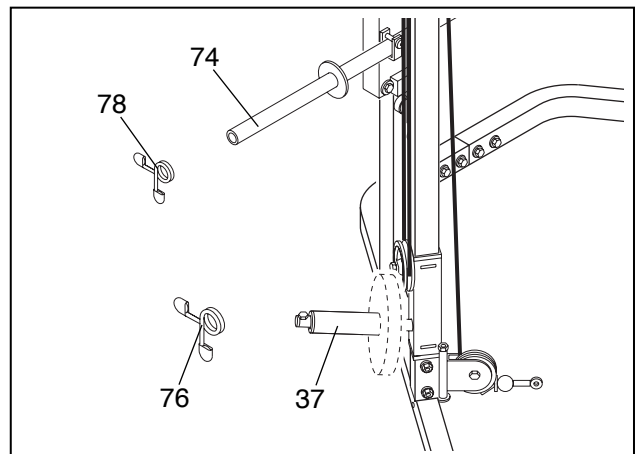



# Exercise Guidelines

## THE FOUR BASIC TYPES OF WORKOUTS

### Muscle Building

The only way to increase the size and strength of your muscles is to push them close to their maximum capacity. When you progressively increase the intensity of your exercise, your muscles will continually adapt and grow. You can tailor the individual exercise to the proper intensity level in two ways:

- by changing the amount of weight used
- by changing the number of repetitions or sets performed (A “repetition” is one complete cycle of an exercise, such as one sit-up. A “set” is a series of repetitions).

The proper amount of weight for each exercise obviously depends upon the individual user. You must gauge your limits and select the amount of weight that is right for you. Begin with 3 sets of 8 repetitions for each exercise you perform. Rest for 3 minutes after each set. When you can complete 3 sets of 12 repetitions without difficulty, increase the amount of weight.

### Toning

You can tone your muscles by pushing them to a moderate percentage of their capacity. Select a moderate amount of weight and increase the number of repetitions in each set. Complete as many sets of 15 to 20 repetitions as possible without discomfort. Rest for 1 minute after each set. Work your muscles by completing more sets rather than by using high amounts of weight.

### Weight Loss

To lose weight, use a low amount of weight and increase the number of repetitions in each set. Exercise for 20 to 30 minutes, resting for a maximum of 30 seconds between sets.

### Cross Training

Many people desire a complete and well-balanced fitness program, and cross training is a very efficient way to accomplish this. One example of a balanced program is:

- Plan weight training workouts on Monday, Wednesday and Friday.
- Plan 20 to 30 minutes of aerobic exercise, such as cycling, running or swimming on Tuesday and Thursday.
- Rest from both weight training and aerobic exercise for at least one full day each week to give your body time to regenerate.

The combination of weight training and aerobic exercise will reshape and strengthen your body plus develop your heart and lungs.

## PERSONALIZING YOUR EXERCISE PROGRAM

Specifying the exact length of time for each workout, as well as the number of repetitions or sets for each exercise, is a highly individual matter. It is very important to avoid overdoing it during the first few months of your exercise program. You should progress at your own pace and be sensitive to your body's signals. If you experience pain or dizziness at any time while exercising, stop immediately and begin cooling down. Find out what is wrong before continuing. Remember that adequate rest and a proper diet are important factors in any exercise program.

### WARMING UP

Begin each workout with 5 to 10 minutes of stretching and light exercise to warm up. Warming up prepares your body for more strenuous exercise by increasing circulation, raising your body temperature and delivering more oxygen to your muscles.

### WORKING OUT

Each workout should include 6 to 10 different exercises. Select exercises for every major muscle group with emphasis on the areas that you want to develop the most. To give balance and variety to your workouts, vary the exercises from session to session.

Schedule your workouts for the time of day when your energy level is the highest. Each workout should be followed by at least one day of rest. Once you find the schedule that is right for you, stick with it.

### EXERCISE FORM

You will gain the greatest benefits from exercising by maintaining proper form. This requires moving through the full range of motion for each exercise and moving only the appropriate parts of the body. Exercising in an uncontrolled manner will leave you feeling exhausted. On the exercise poster accompanying this manual, you will find photographs showing the correct form for several exercises. A description of each exercise is also provided, along with a list of the muscles affected. Refer to the muscle chart on page 18 to find the locations of the muscles.

The repetitions in each set should be performed smoothly and without pausing. The exertion stage of each repetition should last about half as long as the return stage. Proper breathing is important. Exhale during the exertion stage of each repetition and inhale during the return stroke. Never hold your breath!

You should rest for a short period of time after each set. The ideal resting periods are:

- Rest three minutes after each set for a muscle building workout
- Rest one minute after each set for a toning workout
- Rest 30 seconds after each set for a weight loss workout

Plan to spend the first couple of weeks familiarizing yourself with the equipment and learning the proper form for each exercise.

### COOLING DOWN

End each workout with 5 to 10 minutes of stretching. Include stretches for both your arms and legs. Move slowly as you stretch and do not bounce. Ease into each stretch gradually and go only as far as you can

without strain. Stretching at the end of each workout is very effective for increasing flexibility.

### STAYING MOTIVATED

For motivation, keep a record of each workout. The chart on page 19 of this manual can be photocopied and used to schedule and record your workouts. List the date, the exercises performed, the weight plus the numbers of sets and repetitions completed. Record your weight and key body measurements at the end of every month.

Remember, the key to achieving the greatest results is to make exercise a regular and enjoyable part of your everyday life.

### MUSCLE CHART

- A. Sternomastoid (neck)
- B. Pectoralis Major (chest)
- C. Biceps (front of arm)
- D. Obliques (waist)
- E. Brachioradials (forearm)
- F. Hip Flexors (upper thigh)
- G. Abductor (outer thigh)
- H. Quadriceps (front of thigh)
- I. Sartorius (front of thigh)
- J. Tibialis Anterior (front of calf)
- K. Soleus (front of calf)
- L. Rectus Abdominus (stomach)
- M. Adductor (inner thigh)
- N. Trapezius (upper back)
- O. Rhomboideus (upper back)
- P. Deltoid (shoulder)
- Q. Triceps (back of arm)
- R. Latissimus Dorsi (mid back)
- S. Spinae Erectors (lower back)
- T. Gluteus Medius (hip)
- U. Gluteus Maximus (buttocks)
- V. Hamstring (back of leg)
- W. Gastrocnemius (back of calf)

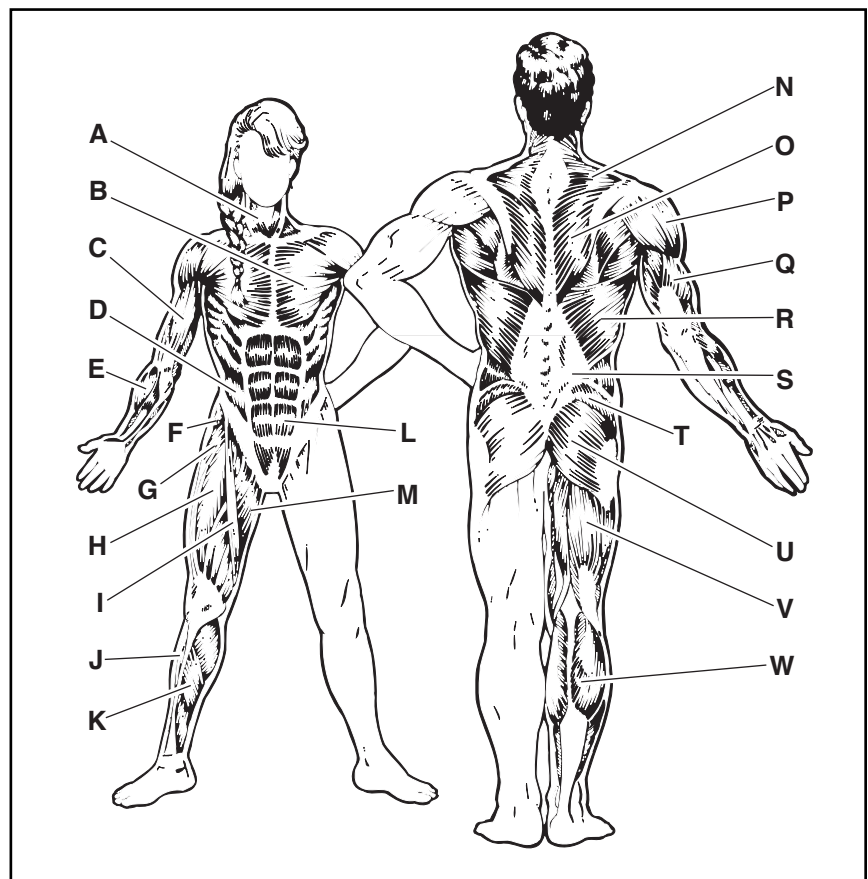

|                                     |                 |               |             |             |
|-------------------------------------|-----------------|---------------|-------------|-------------|
| <b>MONDAY</b><br>Date:<br>_ / _ / _ | <b>EXERCISE</b> | <b>WEIGHT</b> | <b>SETS</b> | <b>REPS</b> |
|                                     |                 |               |             |             |
|                                     |                 |               |             |             |
|                                     |                 |               |             |             |
|                                     |                 |               |             |             |
|                                     |                 |               |             |             |
|                                     |                 |               |             |             |
|                                     |                 |               |             |             |
|                                     |                 |               |             |             |
|                                     |                 |               |             |             |

**TUESDAY**      **AEROBIC EXERCISE**  
Date:  
\_ / \_ / \_

|  |                 |               |             |             |
|--|-----------------|---------------|-------------|-------------|
| <b>WEDNESDAY</b><br>Date:<br>_ / _ / _ | <b>EXERCISE</b> | <b>WEIGHT</b> | <b>SETS</b> | <b>REPS</b> |
|  |                 |               |             |             |
|  |                 |               |             |             |
|  |                 |               |             |             |
|  |                 |               |             |             |
|  |                 |               |             |             |
|  |                 |               |             |             |
|  |                 |               |             |             |
|  |                 |               |             |             |
|  |                 |               |             |             |

**THURSDAY**      **AEROBIC EXERCISE**  
Date:  
\_ / \_ / \_

|                                     |                 |               |             |             |
|-------------------------------------|-----------------|---------------|-------------|-------------|
| <b>FRIDAY</b><br>Date:<br>_ / _ / _ | <b>EXERCISE</b> | <b>WEIGHT</b> | <b>SETS</b> | <b>REPS</b> |
|                                     |                 |               |             |             |
|                                     |                 |               |             |             |
|                                     |                 |               |             |             |
|                                     |                 |               |             |             |
|                                     |                 |               |             |             |
|                                     |                 |               |             |             |
|                                     |                 |               |             |             |
|                                     |                 |               |             |             |
|                                     |                 |               |             |             |

Make photocopies of this page for scheduling and recording your workouts.

# Part List - Model No. PFBE66080

R0200A

| Key No. | Qty. | Description           | Key No. | Qty. | Description            |
|---------|------|-----------------------|---------|------|------------------------|
| 1       | 25   | M10 Nylon Locknut     | 42      | 2    | Weight Upright         |
| 2       | 13   | M6 Nylon Locknut      | 43      | 2    | M10 x 93mm Bolt        |
| 3       | 4    | M6 x 16mm Screw       | 44      | 1    | Decline Carriage       |
| 4       | 4    | M6 x 38mm Screw       | 45      | 2    | Cable                  |
| 5       | 16   | M10 x 65mm Bolt       | 46      | 1    | Left Seat Bracket      |
| 6       | 34   | M10 Washer            | 47      | 10   | Weight Adapter Bushing |
| 7       | 5    | M6 x 32mm Bolt        | 48      | 3    | Short Weight Adapter   |
| 8       | 1    | M10 x 145mm Bolt      | 49      | 1    | Angle Cap              |
| 9       | 1    | Right Seat Bracket    | 50      | 1    | 1/2" Spacer            |
| 10      | 6    | 6" Foam Pad           | 51      | 1    | Weight Tube            |
| 11      | 1    | Decline Strut         | 52      | 1    | M8 x 70mm Bolt         |
| 12      | 3    | 1" Round Inner cap    | 53      | 2    | Backrest Tube          |
| 13      | 4    | M8 Nylon Locknut      | 54      | 1    | Frame                  |
| 14      | 1    | Seat                  | 55      | 2    | Ankle Strap            |
| 15      | 1    | Backrest              | 56      | 6    | Carriage Bushing       |
| 16      | 1    | Support Plate         | 57      | 4    | 1" Square Inner Cap    |
| 17      | 12   | 2" Square Inner Cap   | 58      | 1    | M8 x 62mm Bolt         |
| 18      | 1    | Leg Lever             | 59      | 1    | M10 x 72mm Bolt        |
| 19      | 1    | Pad Upright           | 60      | 4    | 1/2" Nylon Locknut     |
| 20      | 1    | Stabilizer            | 61      | 2    | Barbell Adapter        |
| 21      | 4    | Plastic Washer        | 62      | 1    | Lock                   |
| 22      | 3    | Thin M8 Washer        | 63      | 1    | Short "L" Pin          |
| 23      | 2    | Safety Stop           | 64      | 2    | Cable Clip             |
| 24      | 1    | Top Frame             | 65      | 6    | 3/4" Round Inner Cap   |
| 25      | 1    | Right Base            | 66      | 1    | Lock Spacer            |
| 26      | 1    | Left Base             | 67      | 2    | Short Pad Tube         |
| 27      | 1    | Joiner Bracket        | 68      | 24   | M6 Washer              |
| 28      | 4    | Pulley Bracket        | 69      | 2    | Handle Frame           |
| 29      | 2    | Weight Hook           | 70      | 2    | Push Nut               |
| 30      | 2    | M8 x 14mm Screw       | 71      | 1    | Long "L"-Pin           |
| 31      | 2    | Barbell Rack          | 72      | 1    | M10 x 75mm Bolt        |
| 32      | 8    | Roller Bushing        | 73      | 4    | M10 x 50mm Bolt        |
| 33      | 8    | M6 x 61mm Bolt        | 74      | 1    | Barbell                |
| 34      | 4    | M8 x 41mm Bolt        | 75      | 4    | Plastic Sleeve         |
| 35      | 8    | 3" Pulley             | 76      | 2    | Spring Clip            |
| 36      | 2    | Handle with Foam Grip | 77      | 1    | Long Pad Tube          |
| 37      | 2    | Weight Carriage       | 78      | 2    | 1" Spring Clip         |
| 38      | 2    | M8 x 68mm Bolt        | 79      | 2    | Small Plastic Sleeve   |
| 39      | 2    | M10 x 39mm Bolt       | #       | 1    | Allen Wrench           |
| 40      | 4    | Cable Trap            | #       | 1    | User's Manual          |
| 41      | 2    | Barbell Upright       | #       | 1    | Exercise Guide         |

Note: "#" indicates a non-illustrated part. Specifications are subject to change without notice. See the back cover of the user's manual for information about ordering replacement parts.

# Exploded Drawing - Model No. PFBE66080

R0200A

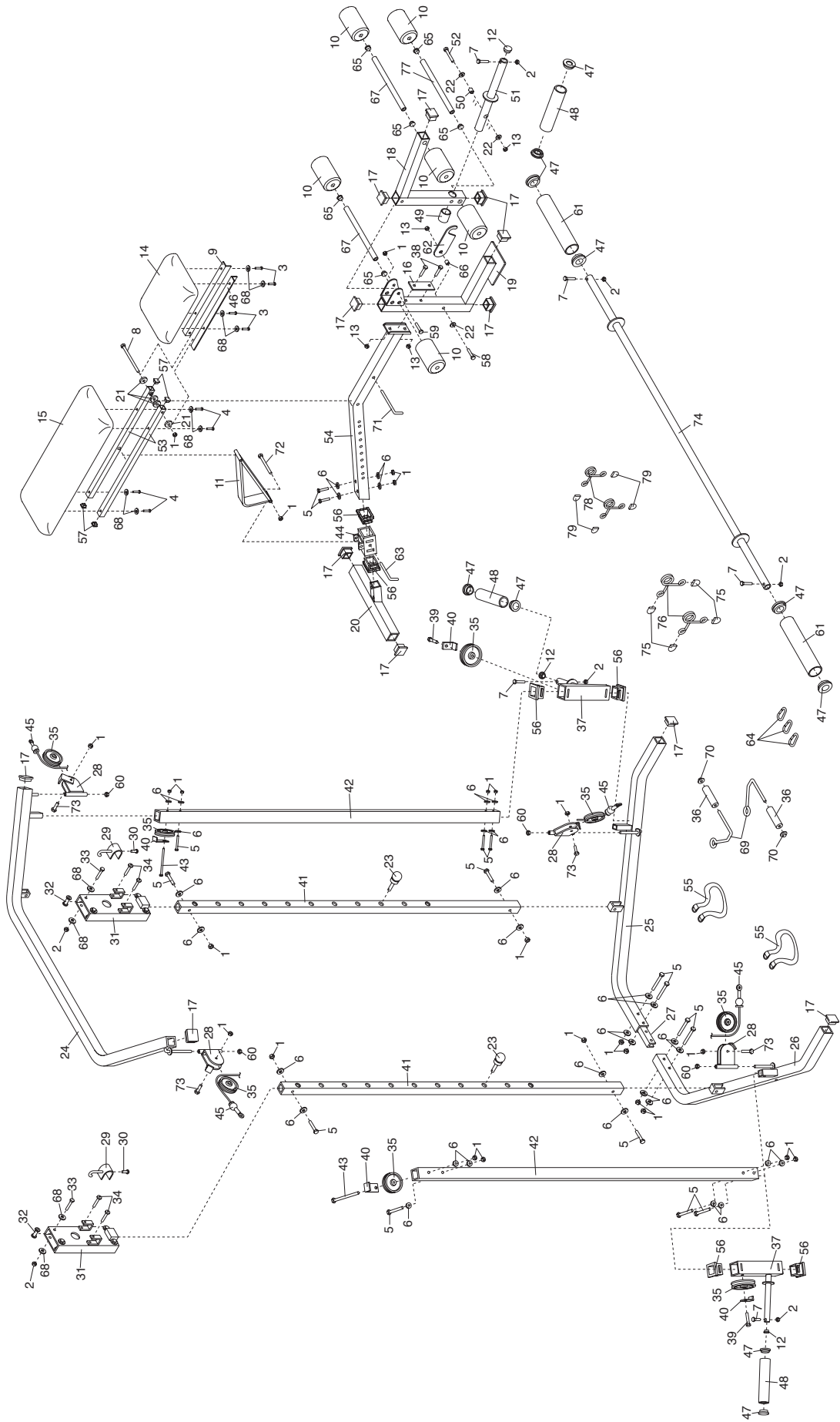

# Ordering Replacement Parts

To order replacement parts, simply call our Customer Service Department toll-free at 1-800-999-3756, Monday through Friday, 6 a.m. until 6 p.m. Mountain Time (excluding holidays). To help us assist you, please be prepared to give the following information when calling:

1. The MODEL NUMBER of the product (PFBE66080).
2. The NAME of the product (PROFORM 660 Weight Bench).
3. The SERIAL NUMBER of the product (see the front cover of this manual).
4. The KEY NUMBER and DESCRIPTION of the desired part(s) (see the PART LIST and the EXPLODED DRAWING at the center of this manual).

## Limited Warranty

ICON Health & Fitness, Inc. (ICON), warrants this product to be free from defects in workmanship and material, under normal use and service conditions, for a period of ninety (90) days from the date of purchase. This warranty extends only to the original purchaser. ICON's obligation under this warranty is limited to replacing or repairing, at ICON's option, the product at one of its authorized service centers. All products for which warranty claim is made must be received by ICON at one of its authorized service centers with all freight and other transportation charges prepaid, accompanied by sufficient proof of purchase. All returns must be pre-authorized by ICON. This warranty does not extend to any product or damage to a product caused by or attributable to freight damage, abuse, misuse, improper or abnormal usage or repairs not provided by an ICON authorized service center, products used for commercial or rental purposes, or products used as store display models. No other warranty beyond that specifically set forth above is authorized by ICON.

ICON is not responsible or liable for indirect, special or consequential damages arising out of or in connection with the use or performance of the product or damages with respect to any economic loss, loss of property, loss of revenues or profits, loss of enjoyment or use, costs of removal, installation or other consequential damages of whatsoever nature. Some states do not allow the exclusion or limitation of incidental or consequential damages. Accordingly, the above limitation may not apply to you.

The warranty extended hereunder is in lieu of any and all other warranties and any implied warranties of merchantability or fitness for a particular purpose is limited in its scope and duration to the terms set forth herein. Some states do not allow limitations on how long an implied warranty lasts. Accordingly, the above limitation may not apply to you.

This warranty gives you specific legal rights. You may also have other rights which vary from state to state.

**ICON HEALTH & FITNESS, INC., 1500 S. 1000 W., LOGAN, UT 84321-9813**

PROFORM is a registered trademark of ICON Health & Fitness, Inc.

## Free Manuals Download Website

<http://myh66.com>

<http://usermanuals.us>

<http://www.somanuals.com>

<http://www.4manuals.cc>

<http://www.manual-lib.com>

<http://www.404manual.com>

<http://www.luxmanual.com>

<http://aubethermostatmanual.com>

Golf course search by state

<http://golfingnear.com>

Email search by domain

<http://emailbydomain.com>

Auto manuals search

<http://auto.somanuals.com>

TV manuals search

<http://tv.somanuals.com>